



**THE DATASHEET OF
BD6422EFV-E2**



Stepping Motor Driver series

High Voltage Series Stepping Motor Drivers



BD6422EFV (PARALLEL-IN type)
BD6425, BD6423EFV (CLK-IN type)

No.12009EAT06

●Description

These products are a low power consumption PWM constant current-drive driver of bipolar stepping motor with power supply's rated voltage of 45V and rated output current of 1.0A, 1.5A.

●Feature

- 1) Power supply: one system drive (rated voltage of 45V)
- 2) Rated output current: 1.0A, 1.5A
- 3) Low ON resistance DMOS output
- 4) CLK-IN drive mode (BD6425/6423EFV)
- 5) Parallel IN drive mode (BD6422EFV)
- 6) PWM constant current control (other oscillation)
- 7) Built-in spike noise blanking function (external noise filter is unnecessary)
- 8) FULL STEP & HALF STEP (two kinds), applicable to QUARTER STEP
- 9) Current decay mode switching function (4 kinds of FAST/SLOW DECAY ratio)
- 10) Normal rotation & reverse rotation switching function (BD6425/6423EFV)
- 11) Power save function
- 12) Built-in logic input pull-down resistor
- 13) Power-on reset function(BD6425/6423EFV)
- 14) Thermal shutdown circuit (TSD)
- 15) Over current protection circuit (OCP)
- 16) Under voltage lock out circuit (UVLO)
- 17) Malfunction prevention at the time of no applied power supply (Ghost Supply Prevention)
- 18) Electrostatic discharge: 8kV (HBM specification)
- 19) Microminiature, ultra-thin and high heat-radiation (exposed metal type) HTSSOP package

●Application

serial dot impact printer, sewing machine etc.

●Absolute maximum ratings(Ta=25°C)

Item	Symbol	BD6425EFV	BD6423/6422EFV	Unit
Supply voltage	$V_{CC1,2}$	-0.2~+45.0	-0.2~+45.0	V
Power dissipation	Pd	1.45 ^{*1}	1.1 ^{*3}	W
		4.70 ^{*2}	4.0 ^{*4}	W
Input voltage for control pin	V_{IN}	-0.2~+5.5	-0.2~+5.5	V
RNF maximum voltage	V_{RNF}	0.7	0.7	V
Maximum output current	I_{OUT}	1.5 ^{*5}	1.0 ^{*5}	A/phase
Operating temperature range	T_{opr}	-25~+85	-25~+85	°C
Storage temperature range	T_{stg}	-55~+150	-55~+150	°C
Junction temperature	T_{jmax}	+150	+150	°C

^{*1} 70mm × 70mm × 1.6mm glass epoxy board. Derating in done at 11.6mW/°C for operating above Ta=25°C.

^{*2} 4-layer recommended board. Derating in done at 37.6mW/°C for operating above Ta=25°C.

^{*3} 70mm × 70mm × 1.6mm glass epoxy board. Derating in done at 8.8mW/°C for operating above Ta=25°C.

^{*4} 4-layer recommended board. Derating in done at 32.0mW/°C for operating above Ta=25°C.

^{*5} Do not, however exceed Pd, ASO and Tjmax=150°C.

● Operating conditions (Ta= -25~+85°C)

Item	Symbol	BD6425EFV	BD6423/6422EFV	Unit
Supply voltage	V _{CC1,2}	19~42		V
Maximum Output current (DC)	I _{OUT}	1.2* ⁶	0.7* ⁶	A/phase

*⁶ Do not however exceed Pd, ASO.● Electrical characteristics (Unless otherwise specified Ta=25°C, V_{CC1,2}=37V)

Item	Symbol	Limit			Unit	Condition
		Min.	Typ.	Max.		
Whole						
Circuit current at standby	I _{CCST}	-	1.0	2.5	mA	PS=L
Circuit current	I _{CC}	-	2.0	5.0	mA	PS=H, VREF=3V
Control input						
H level input voltage	V _{INH}	2.0	-	-	V	
L level input voltage	V _{INL}	-	-	0.8	V	
H level input current	I _{INH}	35	50	100	μA	V _{IN} =5V
L level input current	I _{INL}	-10	0	-	μA	V _{IN} =0V
Output (OUT1A, OUT1B, OUT2A, OUT2B)						
Output ON resistance(BD6425EFV)	R _{ON}	-	1.10	1.43	Ω	I _{OUT} =1.0A, Sum of upper and lower
Output ON resistance(BD6423/6422EFV)	R _{ON}	-	2.00	2.60	Ω	I _{OUT} =0.5A, Sum of upper and lower
Output leak current	I _{LEAK}	-	-	10	μA	
Current control						
RNFXS input current (BD6425EFV)	I _{RNFS}	-2.0	-0.1	-	μA	RNFXS=0V
RNFX input current	I _{RNF}	-40	-20	-	μA	RNFX=0V
VREF input current	I _{VREF}	-2.0	-0.1	-	μA	VREF=0V
VREF input voltage range	V _{REF}	0	-	3.0	V	
Minimum on time (Blank time)	t _{ONMIN}	0.5	1.5	3.0	μs	C=470pF, R=82kΩ
BD6425/6423EFV						
Comparator threshold	V _{CTH}	0.57	0.60	0.63	V	VREF=3V
BD6422EFV						
Comparator threshold 100%	V _{CTH100}	0.57	0.60	0.63	V	VREF=3V, (I0X,I1X)=(L,L)
Comparator threshold 67%	V _{CTH67}	0.38	0.40	0.42	V	VREF=3V, (I0X,I1X)=(H,L)
Comparator threshold 33%	V _{CTH33}	0.18	0.20	0.22	V	VREF=3V, (I0X,I1X)=(L,H)

● Terminal function and Application circuit diagram

1) BD6425EFV

Pin No.	Pin name	Function	Pin No.	Pin name	Function
1	GND	Ground terminal	15	CLK	Clock input terminal for advancing the electrical angle.
2	OUT1B	H bridge output terminal	16	CW_CCW	Motor rotating direction setting terminal
3	RNF1	Connection terminal of resistor for output current detection	17	TEST	Terminal for testing (used by connecting with GND)
4	RNF1S	Input terminal of current limit comparator	18	MODE0	Motor excitation mode setting terminal
5	OUT1A	H bridge output terminal	19	MODE1	Motor excitation mode setting terminal
6	NC	Non connection	20	ENABLE	Power supply terminal
7	VCC1	Power supply terminal	21	NC	Non connection
8	NC	Non connection	22	VCC2	Power supply terminal
9	GND	Ground terminal	23	NC	Non connection
10	CR	Connection terminal of CR for setting chopping frequency	24	OUT2A	H bridge output terminal
11	DEC1	Current decay mode setting terminal	25	RNF2S	Input terminal of current limit comparator
12	DEC2	Current decay mode setting terminal	26	RNF2	Connection terminal of resistor for output current detection
13	VREF	Output current value setting terminal	27	OUT2B	H bridge output terminal
14	PS	Power save terminal	28	NC	Non connection

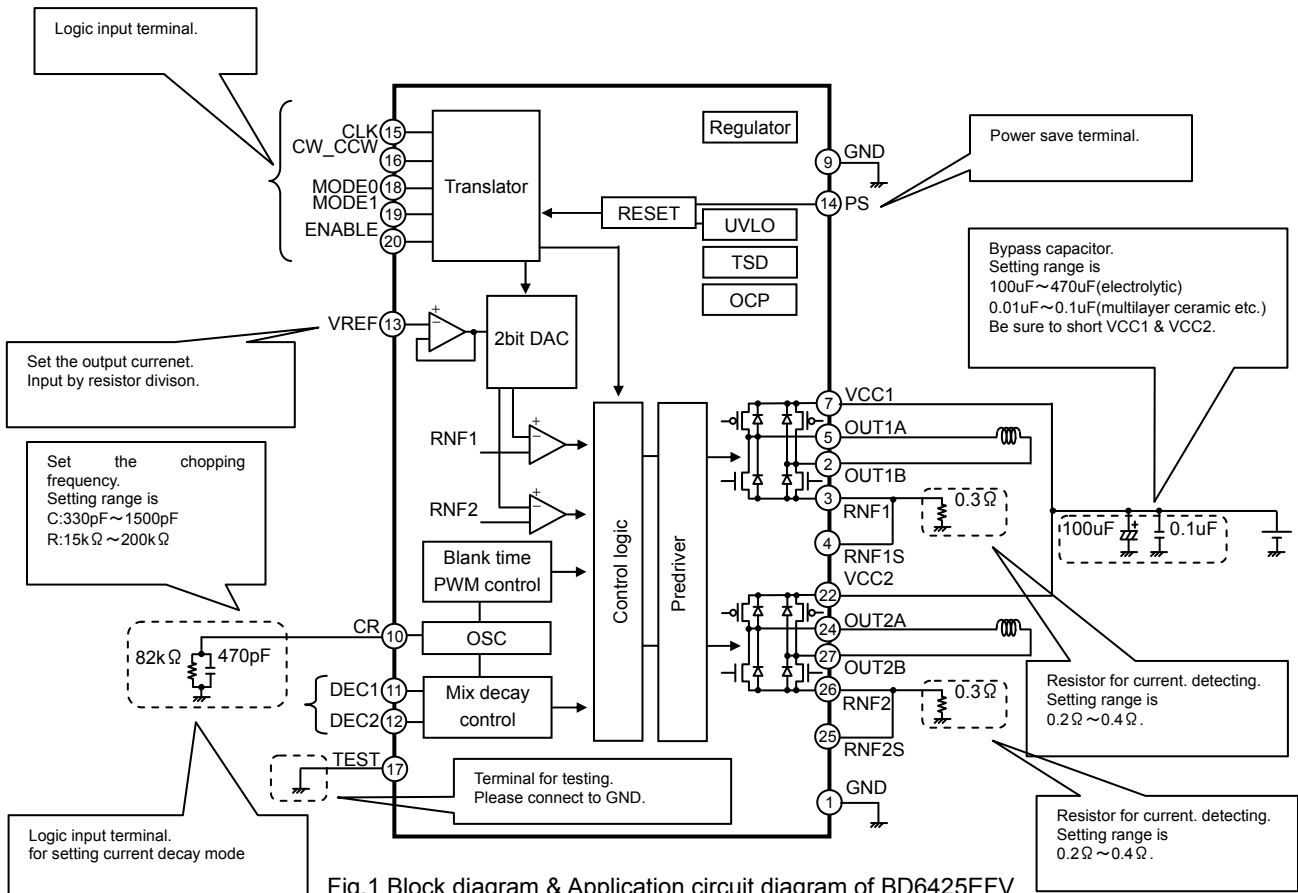

2) BD6423EFV

Pin No.	Pin name	Function	Pin No.	Pin name	Function
1	GND	Ground terminal	13	CLK	Clock input terminal for advancing the electrical angle.
2	OUT1B	H bridge output terminal	14	CW_CCW	Motor rotating direction setting terminal
3	RNF1	Connection terminal of resistor for output current detection	15	TEST	Terminal for testing (used by connecting with GND)
4	OUT1A	H bridge output terminal	16	MODE0	Motor excitation mode setting terminal
5	VCC1	Power supply terminal	17	MODE1	Motor excitation mode setting terminal
6	NC	Non connection	18	ENABLE	Output enable terminal
7	GND	Ground terminal	19	NC	Non connection
8	CR	Connection terminal of CR for setting PWM frequency	20	VCC2	Power supply terminal
9	DEC1	Current decay mode setting terminal	21	OUT2A	H bridge output terminal
10	DEC2	Current decay mode setting terminal	22	RNF2	Connection terminal of resistor for output current detection
11	VREF	Output current value setting terminal	23	OUT2B	H bridge output terminal
12	PS	Power save terminal	24	NC	Non connection

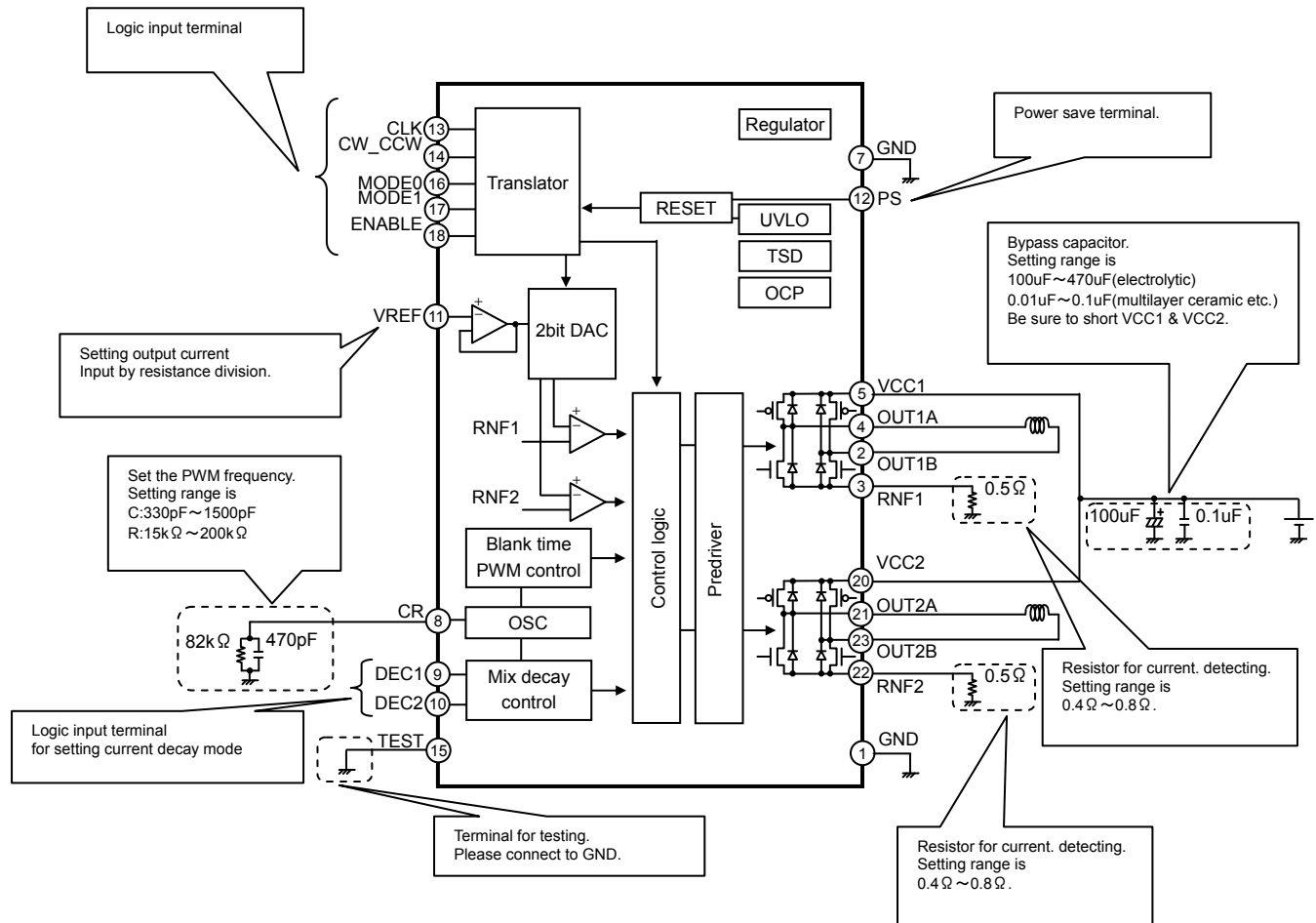

Fig.2 Block diagram & Application circuit diagram of BD6423EFV

3) BD6422EFV

Pin No.	Pin name	Function	Pin No.	Pin name	Function
1	GND	Ground terminal	13	PHASE1	Phase selection terminal
2	OUT1B	H bridge output terminal	14	I01	VREF division ratio setting terminal
3	RNF1	Connection terminal of resistor for output current detection	15	I11	VREF division ratio setting terminal
4	OUT1A	H bridge output terminal	16	PHASE2	Phase selection terminal
5	VCC1	Power supply terminal	17	I02	VREF division ratio setting terminal
6	NC	Non connection	18	I12	VREF division ratio setting terminal
7	GND	Ground terminal	19	NC	Non connection
8	CR	Connection terminal of CR for setting PWM frequency	20	VCC2	Power supply terminal
9	DEC1	Current decay mode setting terminal	21	OUT2A	H bridge output terminal
10	DEC2	Current decay mode setting terminal	22	RNF2	Connection terminal of resistor for output current detection
11	VREF	Output current value setting terminal	23	OUT2B	H bridge output terminal
12	PS	Power save terminal	24	NC	Non connection

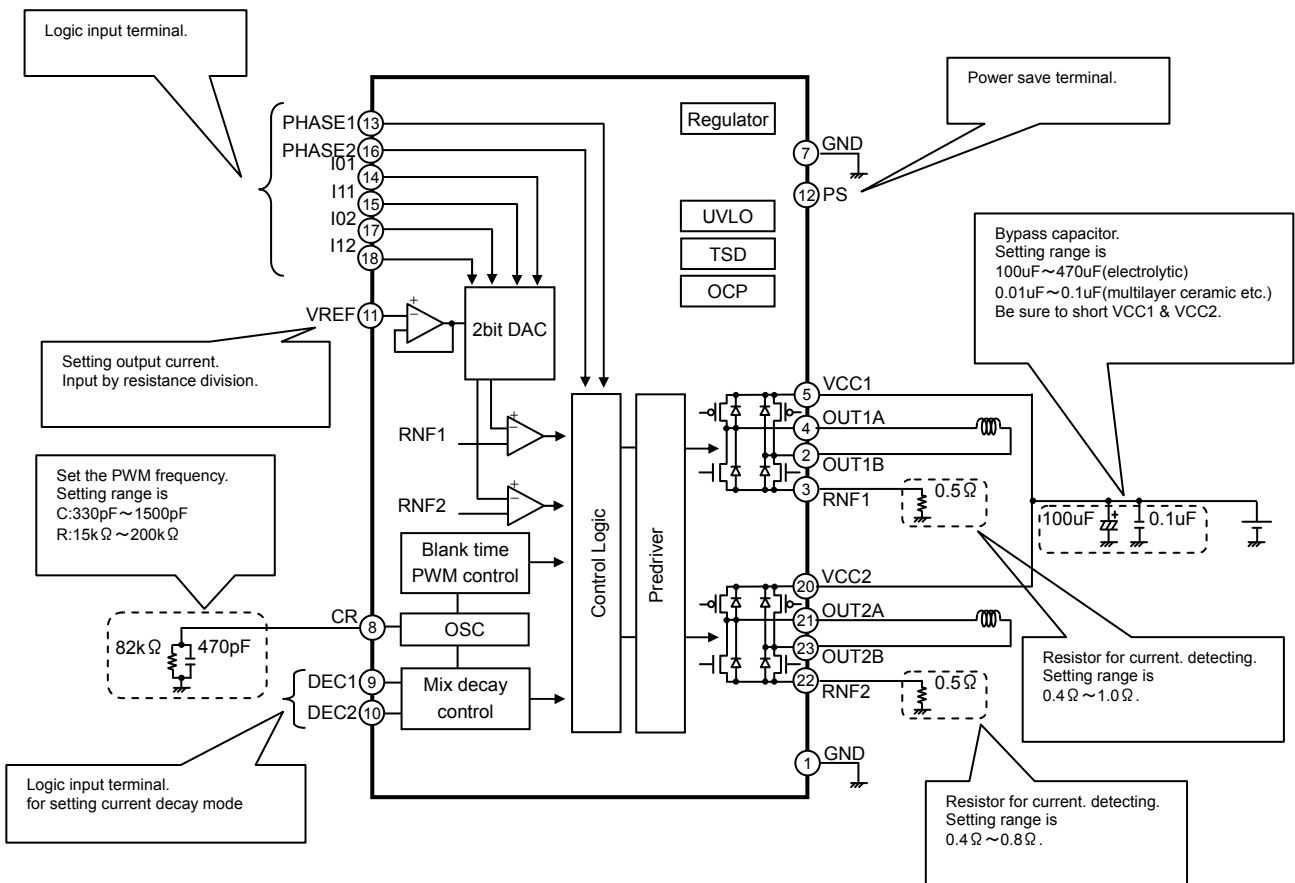

Fig.3 Block diagram & Application circuit diagram of BD6422EFV

● Usage Notes

(1) Absolute maximum ratings

An excess in the absolute maximum ratings, such as supply voltage, temperature range of operating conditions, etc., can break down the devices, thus making impossible to identify breaking mode, such as a short circuit or an open circuit. If any over rated values will expect to exceed the absolute maximum ratings, consider adding circuit protection devices, such as fuses.

(2) Connecting the power supply connector backward

Connecting of the power supply in reverse polarity can damage IC. Take precautions when connecting the power supply lines. An external direction diode can be added.

(3) Power supply Lines

Design PCB layout pattern to provide low impedance GND and supply lines. To obtain a low noise ground and supply line, separate the ground section and supply lines of the digital and analog blocks. Furthermore, for all power supply terminals to ICs, connect a capacitor between the power supply and the GND terminal. When applying electrolytic capacitors in the circuit, not that capacitance characteristic values are reduced at low temperatures.

(4) GND Potential

The potential of GND pin must be minimum potential in all operating conditions.

(5) Metal on the backside (Define the side where product markings are printed as front)

The metal on the backside is shorted with the backside of IC chip therefore it should be connected to GND. Be aware that there is a possibility of malfunction or destruction if it is shorted with any potential other than GND.

(6) Thermal design

Use a thermal design that allows for a sufficient margin in light of the power dissipation (Pd) in actual operating conditions. Users should be aware that these products have been designed to expose their frames at the back of the package, and should be used with suitable heat dissipation treatment in this area to improve dissipation. As large a dissipation pattern should be taken as possible, not only on the front of the baseboard but also on the back surface. It is important to consider actual usage conditions and to take as large a dissipation pattern as possible.

(7) Inter-pin shorts and mounting errors

When attaching to a printed circuit board, pay close attention to the direction of the IC and displacement. Improper attachment may lead to destruction of the IC. There is also possibility of destruction from short circuits which can be caused by foreign matter entering between outputs or an output and the power supply or GND.

(8) Operation in a strong electric field

Use caution when using the IC in the presence of a strong electromagnetic field as doing so may cause the IC to malfunction.

(9) ASO

When using the IC, set the output transistor so that it does not exceed absolute maximum ratings or ASO.

(10) Thermal shutdown circuit

The IC has a built-in thermal shutdown circuit (TSD circuit). If the chip temperature becomes $T_{jmax}=150^{\circ}\text{C}$, and higher, coil output to the motor will be open. The TSD circuit is designed only to shut the IC off to prevent runaway thermal operation. It is not designed to protect or indemnify peripheral equipment. Do not use the TSD function to protect peripheral equipment.

TSD on temperature [$^{\circ}\text{C}$] (Typ.)	Hysteresis Temperature [$^{\circ}\text{C}$] (Typ.)
175	25

(11) Inspection of the application board

During inspection of the application board, if a capacitor is connected to a pin with low impedance there is a possibility that it could cause stress to the IC, therefore an electrical discharge should be performed after each process. Also, as a measure against electrostatic discharge, it should be earthed during the assembly process and special care should be taken during transport or storage. Furthermore, when connecting to the jig during the inspection process, the power supply should first be turned off and then removed before the inspection.

(12) Input terminal of IC

This IC is a monolithic IC, and between each element there is a P+ isolation for element partition and a P substrate. This P layer and each element's N layer make up the P-N junction, and various parasitic elements are made up. For example, when the resistance and transistor are connected to the terminal as shown in figure 4,

○When GND > (Terminal A) at the resistance and GND > (Terminal B) at the transistor (NPN), the P-N junction operates as a parasitic diode.

○Also, when GND > (Terminal B) at the transistor (NPN)

The parasitic NPN transistor operates with the N layers of other elements close to the aforementioned parasitic diode.

Because of the IC's structure, the creation of parasitic elements is inevitable from the electrical potential relationship. The operation of parasitic elements causes interference in circuit operation, and can lead to malfunction and destruction. Therefore, be careful not to use it in a way which causes the parasitic elements to operate, such as by applying voltage that is lower than the GND (P substrate) to the input terminal.

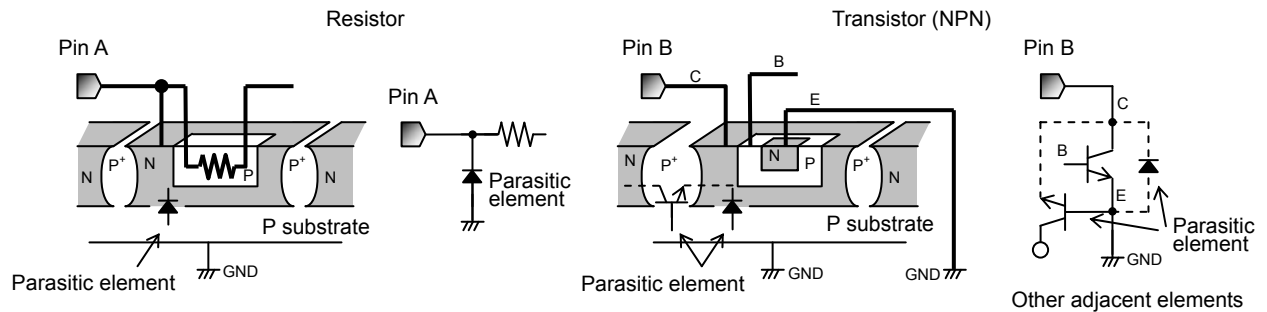

Fig. 4 Pattern Diagram of Parasitic Element

(13) Ground Wiring Patterns

When using both small signal and large current GND patterns, it is recommended to isolate the two ground patterns, placing a single ground point at the application's reference point so that the pattern wiring resistance and voltage variations caused by large currents do not cause variations in the small signal ground voltage. Be careful not to change the GND wiring pattern potential of any external components, either.

(14) TEST Terminal (BD6425/6423EFV)

Be sure to connect TEST pin to GND.

●Ordering part number

B D 6 4 2 2 E F V - E 2

形名	パッケージ EFV=HTSSOP-B24(BD6423EFV /BD6422EFV) EFV=HTSSOP-B28(BD6425EFV)	包装、フォーミング仕様 E2: リール状エンボステーピング
----	--	----------------------------------

HTSSOP-B24

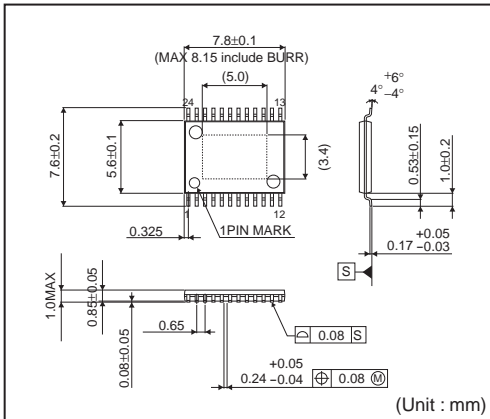

<Tape and Reel information>

Tape	Embossed carrier tape (with dry pack)
Quantity	2000pcs
Direction of feed	E2 (The direction is the 1pin of product is at the upper left when you hold reel on the left hand and you pull out the tape on the right hand)

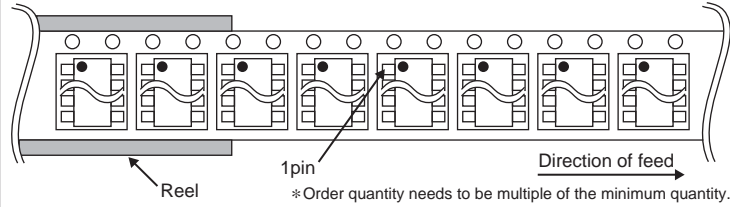

HTSSOP-B28

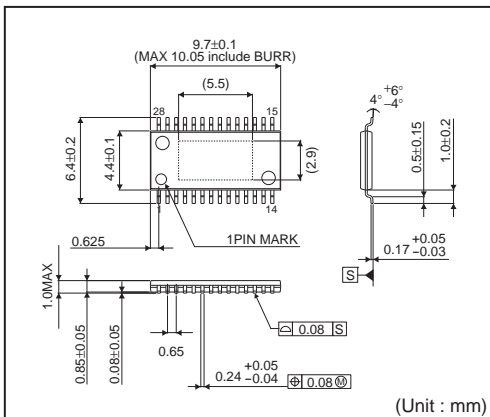

<Tape and Reel information>

Tape	Embossed carrier tape (with dry pack)
Quantity	2500pcs
Direction of feed	E2 (The direction is the 1pin of product is at the upper left when you hold reel on the left hand and you pull out the tape on the right hand)

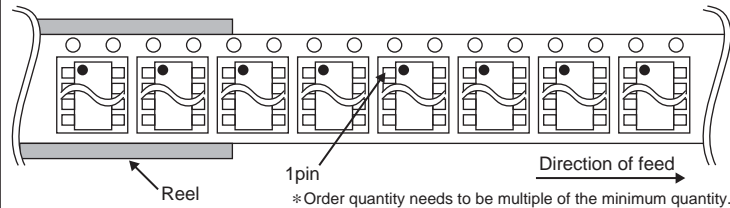

Notice

Precaution on using ROHM Products

- Our Products are designed and manufactured for application in ordinary electronic equipments (such as AV equipment, OA equipment, telecommunication equipment, home electronic appliances, amusement equipment, etc.). If you intend to use our Products in devices requiring extremely high reliability (such as medical equipment ^(Note 1), transport equipment, traffic equipment, aircraft/spacecraft, nuclear power controllers, fuel controllers, car equipment including car accessories, safety devices, etc.) and whose malfunction or failure may cause loss of human life, bodily injury or serious damage to property ("Specific Applications"), please consult with the ROHM sales representative in advance. Unless otherwise agreed in writing by ROHM in advance, ROHM shall not be in any way responsible or liable for any damages, expenses or losses incurred by you or third parties arising from the use of any ROHM's Products for Specific Applications.

(Note1) Medical Equipment Classification of the Specific Applications

JAPAN	USA	EU	CHINA
CLASS III	CLASS III	CLASS II b	CLASS III
CLASS IV		CLASS III	

- ROHM designs and manufactures its Products subject to strict quality control system. However, semiconductor products can fail or malfunction at a certain rate. Please be sure to implement, at your own responsibilities, adequate safety measures including but not limited to fail-safe design against the physical injury, damage to any property, which a failure or malfunction of our Products may cause. The following are examples of safety measures:
 - Installation of protection circuits or other protective devices to improve system safety
 - Installation of redundant circuits to reduce the impact of single or multiple circuit failure
- Our Products are designed and manufactured for use under standard conditions and not under any special or extraordinary environments or conditions, as exemplified below. Accordingly, ROHM shall not be in any way responsible or liable for any damages, expenses or losses arising from the use of any ROHM's Products under any special or extraordinary environments or conditions. If you intend to use our Products under any special or extraordinary environments or conditions (as exemplified below), your independent verification and confirmation of product performance, reliability, etc. prior to use, must be necessary:
 - Use of our Products in any types of liquid, including water, oils, chemicals, and organic solvents
 - Use of our Products outdoors or in places where the Products are exposed to direct sunlight or dust
 - Use of our Products in places where the Products are exposed to sea wind or corrosive gases, including Cl₂, H₂S, NH₃, SO₂, and NO₂
 - Use of our Products in places where the Products are exposed to static electricity or electromagnetic waves
 - Use of our Products in proximity to heat-producing components, plastic cords, or other flammable items
 - Sealing or coating our Products with resin or other coating materials
 - Use of our Products without cleaning residue of flux (even if you use no-clean type fluxes, cleaning residue of flux is recommended); or Washing our Products by using water or water-soluble cleaning agents for cleaning residue after soldering
 - Use of the Products in places subject to dew condensation
- The Products are not subject to radiation-proof design.
- Please verify and confirm characteristics of the final or mounted products in using the Products.
- In particular, if a transient load (a large amount of load applied in a short period of time, such as pulse. is applied, confirmation of performance characteristics after on-board mounting is strongly recommended. Avoid applying power exceeding normal rated power; exceeding the power rating under steady-state loading condition may negatively affect product performance and reliability.
- De-rate Power Dissipation (Pd) depending on Ambient temperature (Ta). When used in sealed area, confirm the actual ambient temperature.
- Confirm that operation temperature is within the specified range described in the product specification.
- ROHM shall not be in any way responsible or liable for failure induced under deviant condition from what is defined in this document.

Precaution for Mounting / Circuit board design

- When a highly active halogenous (chlorine, bromine, etc.) flux is used, the residue of flux may negatively affect product performance and reliability.
- In principle, the reflow soldering method must be used; if flow soldering method is preferred, please consult with the ROHM representative in advance.

For details, please refer to ROHM Mounting specification

Precautions Regarding Application Examples and External Circuits

1. If change is made to the constant of an external circuit, please allow a sufficient margin considering variations of the characteristics of the Products and external components, including transient characteristics, as well as static characteristics.
2. You agree that application notes, reference designs, and associated data and information contained in this document are presented only as guidance for Products use. Therefore, in case you use such information, you are solely responsible for it and you must exercise your own independent verification and judgment in the use of such information contained in this document. ROHM shall not be in any way responsible or liable for any damages, expenses or losses incurred by you or third parties arising from the use of such information.

Precaution for Electrostatic

This Product is electrostatic sensitive product, which may be damaged due to electrostatic discharge. Please take proper caution in your manufacturing process and storage so that voltage exceeding the Products maximum rating will not be applied to Products. Please take special care under dry condition (e.g. Grounding of human body / equipment / solder iron, isolation from charged objects, setting of ionizer, friction prevention and temperature / humidity control).

Precaution for Storage / Transportation

1. Product performance and soldered connections may deteriorate if the Products are stored in the places where:
 - [a] the Products are exposed to sea winds or corrosive gases, including Cl₂, H₂S, NH₃, SO₂, and NO₂
 - [b] the temperature or humidity exceeds those recommended by ROHM
 - [c] the Products are exposed to direct sunshine or condensation
 - [d] the Products are exposed to high Electrostatic
2. Even under ROHM recommended storage condition, solderability of products out of recommended storage time period may be degraded. It is strongly recommended to confirm solderability before using Products of which storage time is exceeding the recommended storage time period.
3. Store / transport cartons in the correct direction, which is indicated on a carton with a symbol. Otherwise bent leads may occur due to excessive stress applied when dropping of a carton.
4. Use Products within the specified time after opening a humidity barrier bag. Baking is required before using Products of which storage time is exceeding the recommended storage time period.

Precaution for Product Label

QR code printed on ROHM Products label is for ROHM's internal use only.

Precaution for Disposition

When disposing Products please dispose them properly using an authorized industry waste company.

Precaution for Foreign Exchange and Foreign Trade act

Since our Products might fall under controlled goods prescribed by the applicable foreign exchange and foreign trade act, please consult with ROHM representative in case of export.

Precaution Regarding Intellectual Property Rights

1. All information and data including but not limited to application example contained in this document is for reference only. ROHM does not warrant that foregoing information or data will not infringe any intellectual property rights or any other rights of any third party regarding such information or data. ROHM shall not be in any way responsible or liable for infringement of any intellectual property rights or other damages arising from use of such information or data.:
2. No license, expressly or implied, is granted hereby under any intellectual property rights or other rights of ROHM or any third parties with respect to the information contained in this document.

Other Precaution



1. This document may not be reprinted or reproduced, in whole or in part, without prior written consent of ROHM.
2. The Products may not be disassembled, converted, modified, reproduced or otherwise changed without prior written consent of ROHM.
3. In no event shall you use in any way whatsoever the Products and the related technical information contained in the Products or this document for any military purposes, including but not limited to, the development of mass-destruction weapons.
4. The proper names of companies or products described in this document are trademarks or registered trademarks of ROHM, its affiliated companies or third parties.

General Precaution





1. Before you use our Products, you are requested to carefully read this document and fully understand its contents. ROHM shall not be in any way responsible or liable for failure, malfunction or accident arising from the use of any ROHM's Products against warning, caution or note contained in this document.
2. All information contained in this document is current as of the issuing date and subject to change without any prior notice. Before purchasing or using ROHM's Products, please confirm the latest information with a ROHM sales representative.
3. The information contained in this document is provided on an "as is" basis and ROHM does not warrant that all information contained in this document is accurate and/or error-free. ROHM shall not be in any way responsible or liable for any damages, expenses or losses incurred by you or third parties resulting from inaccuracy or errors of or concerning such information.

Looking for pricing, stock, or lifecycle information?

Click below to explore more details on WIN SOURCE:

-  [View BD6422EFV-E2 on WIN SOURCE](#)
-  [Rohm Semiconductor](#) Information

Optimize Your Supply Chain with WIN SOURCE Solutions

-  Global Sourcing Solution
-  Obsolete Management
-  Cost Control Management
-  Shortage Management
-  Alternative Solution
-  Excess Inventory Management