



**THE DATASHEET OF  
PRMCE1-S5-S3-S**



**SERIES:** PRMCE1-S | **DESCRIPTION:** DC-DC CONVERTER**FEATURES**

- 1W isolated output
- 3000 Vdc isolation
- compact SIP package
- continuous short circuit protection
- no-load input current as low as 5mA
- wide temperature range: -40°C to +85°C
- high efficiency up to 73%
- UL 62368 certified
- designed to meet EN/BS EN 62368

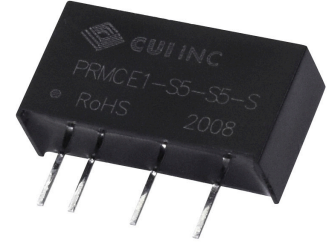

| MODEL                        | input voltage |             | output voltage | output current |          | output power | ripple and noise | efficiency |
|------------------------------|---------------|-------------|----------------|----------------|----------|--------------|------------------|------------|
|                              | typ (Vdc)     | range (Vdc) | (Vdc)          | min (mA)       | max (mA) | max (W)      | max (mVp-p)      | typ (%)    |
| PRMCE1-S5-S3-S               | 5             | 4.75~5.25   | 3.3            | 25             | 250      | 1            | 75               | 67         |
| PRMCE1-S5-S5-S <sup>1</sup>  | 5             | 4.75~5.25   | 5              | 20             | 200      | 1            | 75               | 70         |
| PRMCE1-S5-S9-S <sup>1</sup>  | 5             | 4.75~5.25   | 9              | 12             | 110      | 1            | 75               | 71         |
| PRMCE1-S5-S12-S <sup>1</sup> | 5             | 4.75~5.25   | 12             | 9              | 84       | 1            | 75               | 72         |
| PRMCE1-S5-S15-S <sup>1</sup> | 5             | 4.75~5.25   | 15             | 7              | 67       | 1            | 75               | 73         |
| PRMCE1-S5-S24-S              | 5             | 11.4~12.6   | 24             | 4              | 41       | 1            | 100              | 73         |
| PRMCE1-S12-S5-S              | 12            | 11.4~12.6   | 5              | 20             | 200      | 1            | 100              | 73         |
| PRMCE1-S12-S9-S              | 12            | 11.4~12.6   | 9              | 12             | 111      | 1            | 100              | 73         |
| PRMCE1-S12-S12-S             | 12            | 11.4~12.6   | 12             | 9              | 83       | 1            | 100              | 73         |
| PRMCE1-S12-S15-S             | 12            | 11.4~12.6   | 15             | 7              | 67       | 1            | 150              | 75         |
| PRMCE1-S15-S5-S              | 15            | 14.25~15.75 | 5              | 20             | 200      | 1            | 100              | 73         |
| PRMCE1-S15-S15-S             | 15            | 14.25~15.75 | 15             | 7              | 67       | 1            | 150              | 75         |
| PRMCE1-S24-S3-S              | 24            | 22.8~25.2   | 3.3            | 25             | 250      | 1            | 100              | 71         |
| PRMCE1-S24-S5-S              | 24            | 22.8~25.2   | 5              | 20             | 200      | 1            | 100              | 73         |
| PRMCE1-S24-S9-S              | 24            | 22.8~25.2   | 9              | 12             | 111      | 1            | 100              | 73         |
| PRMCE1-S24-S12-S             | 24            | 22.8~25.2   | 12             | 9              | 83       | 1            | 100              | 73         |
| PRMCE1-S24-S15-S             | 24            | 22.8~25.2   | 15             | 7              | 67       | 1            | 150              | 73         |

Note: 1. Model is UL and CB certified.

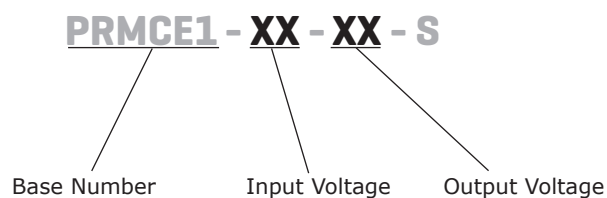
**PART NUMBER KEY**

**INPUT**

| parameter                  | conditions/description | min                     | typ  | max    | units  |    |
|----------------------------|------------------------|-------------------------|------|--------|--------|----|
| input voltage              |                        | 4.75                    | 5    | 5.25   | Vdc    |    |
|                            |                        | 11.4                    | 12   | 12.6   | Vdc    |    |
|                            |                        | 14.25                   | 15   | 15.75  | Vdc    |    |
|                            |                        | 22.8                    | 24   | 25.2   | Vdc    |    |
| filter                     | capacitance filter     |                         |      |        |        |    |
| current                    | 5 Vdc input model      | 3.3,5 Vdc output model  |      | 286/5  | 303/10 | mA |
|                            |                        | 9,12 Vdc output model   |      | 282/12 | 299/20 | mA |
|                            |                        | 15,24 Vdc output model  |      | 274/18 | 290/30 | mA |
|                            | 12 Vdc input model     | 5,9,12 Vdc output model |      | 115/8  | 121/-  | mA |
|                            |                        | 15 Vdc output model     |      | 112/8  | 118/-  | mA |
|                            | 15 Vdc input model     | 5 Vdc output model      |      | 92/8   | 97/-   | mA |
|                            |                        | 15 Vdc output model     |      | 89/8   | 94/-   | mA |
|                            | 24 Vdc input model     | 3.3 Vdc output model    |      | 59/8   | 65/-   | mA |
| 5,9,12,15 Vdc output model |                        | 58/8                    | 63/- | mA     |        |    |

**OUTPUT**

| parameter               | conditions/description                 | min | typ   | max   | units |
|-------------------------|--|-----|-------|-------|-------|
| output capacitance      | 3.3 Vdc output models                  |     |       | 2400  | μF    |
|                         | 5 Vdc output models                    |     |       | 2400  | μF    |
|                         | 9 Vdc output models                    |     |       | 1000  | μF    |
|                         | 12 Vdc output models                   |     |       | 560   | μF    |
|                         | 15 Vdc output models                   |     |       | 560   | μF    |
|                         | 24 Vdc output models                   |     |       | 100   | μF    |
| line regulation         | input voltage change: ±1%              |     |       | ±0.25 | %     |
| load regulation         | 3.3 Vdc output, 10%-100% load          |     |       | ±3    | %     |
|                         | all other output models, 10%-100% load |     |       | ±2    | %     |
| switching frequency     | 100% load, nominal input voltage       |     | 270   |       | kHz   |
| temperature coefficient | 100% load                              |     | ±0.02 |       | %/°C  |

**PROTECTIONS**

| parameter                | conditions/description    | min | typ | max | units |
|--------------------------|---------------------------|-----|-----|-----|-------|
| short circuit protection | continuous, self-recovery |     |     |     |       |

## SAFETY AND COMPLIANCE

| parameter                     | conditions/description   | min   | typ | max | units  |
|-------------------------------|--|-------|-----|-----|--------|
| isolation voltage             | input-output electric strength test for 1 minute with a leakage current of 1mA max | 3,000 |     |     | Vdc    |
| isolation resistance          | input-output resistance at 500 Vdc   | 1,000 |     |     | MΩ     |
| isolation capacitance         | input-output capacitance at 100 KHz / 0.1 V  |       | 20  |     | pF     |
| safety approvals <sup>1</sup> | certified to 62368: UL<br>designed to meet 62368: EN/BS EN                         |       |     |     |        |
| EMI /EMC                      | CISPR32/EN55032 Class B (see recommended circuit)                                  |       |     |     |        |
| ESD                           | IEC/EN61000-4-2 Air ±8kV, Contact ±4kV perf. Criteria B                            |       |     |     |        |
| RoHS                          | yes  |       |     |     |        |
| MTBF                          | as per MIL-HDBK-217F at 25°C   | 3,500 |     |     | kHours |

Note: 1. Refer to the model table.

## ENVIRONMENTAL

| parameter             | conditions/description                         | min | typ | max | units |
|-----------------------|--|-----|-----|-----|-------|
| operating temperature | derating when operating temperature up to 71°C | -40 |     | 85  | °C    |
| storage temperature   |  | -55 |     | 125 | °C    |
| humidity              | non-condensing                                 |     |     | 95  | %     |
| shock/vibration       | 10-150Hz, 5G, 30 Min. along X, Y and Z         |     |     |     |       |

## MECHANICAL

| parameter     | conditions/description                                       | min | typ | max | units |
|---------------|--|-----|-----|-----|-------|
| dimensions    | 19.65 x 6.00 x 10.16   |     |     |     | mm    |
| case material | black plastic; flame-retardant and heat-resistant (UL94 V-0) |     |     |     |       |
| weight        |  |     | 2.1 |     | g     |

## MECHANICAL DRAWING

units: mm [inches]

tolerance: ± 0.25 [±0.010]

pin section tolerances: ± 0.10 [±0.004]

| PIN-OUT |          |
|---------|----------|
| PIN     | FUNCTION |
| 1       | Vin      |
| 2       | GND      |
| 4       | 0V       |
| 6       | +Vo      |

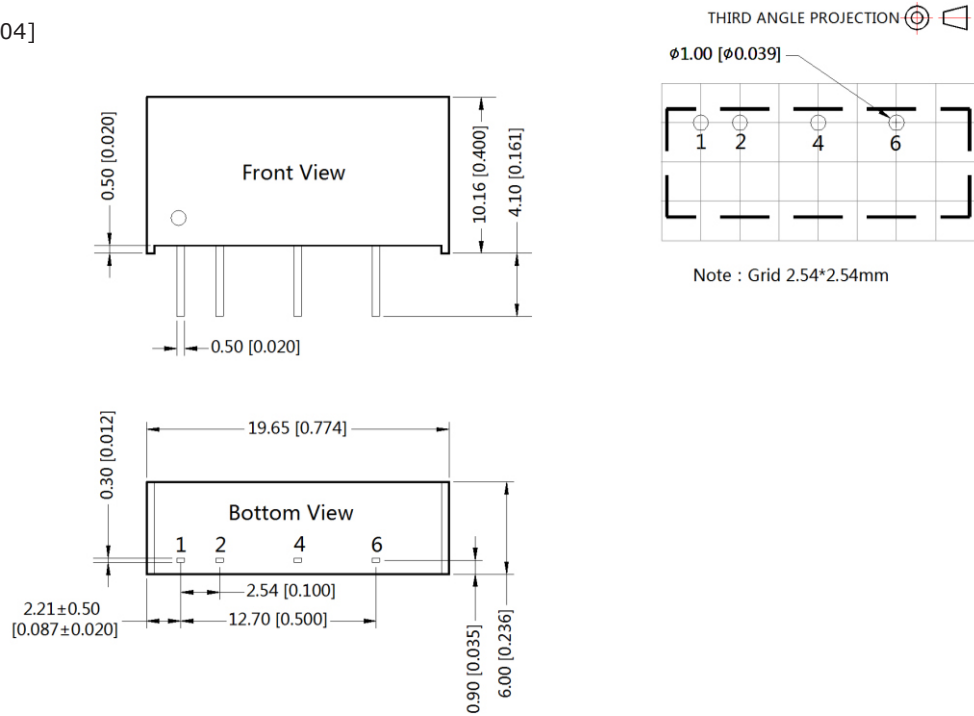

## DERATING CURVE

Figure 1

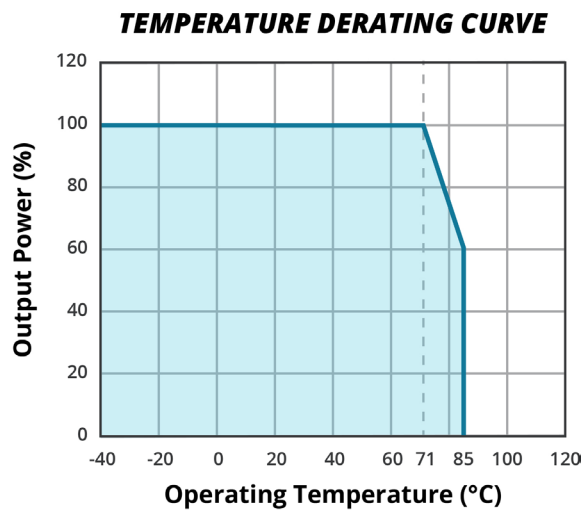

## APPLICATION CIRCUIT

Input and/or output ripple can be further reduced, by connecting a filter capacitor from the input and/or output terminals to ground as shown in Fig.2.

Choosing suitable filter capacitor values is very important for a smooth operation of the modules, particularly to avoid start-up problems caused by capacitor values that are too high. For recommended input and output capacitor values refer to Table 1.

Figure 2

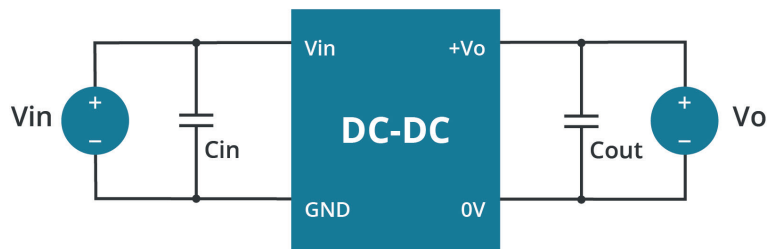

Table 1

| Recommended Input & Output Capacitor Values |              |          |               |
|---|--------------|----------|---------------|
| Vin (Vdc)                                   | Cin (μF / V) | Vo (Vdc) | Cout (μF / V) |
| 5   | 4.7 / -      | 3.3/5    | 10            |
| --  | --           | 9/12     | 2.2           |
| --  | --           | 15       | 1             |
| 12  | 2.2 / 25     | 3.3      | 10 / 16       |
| 15  | 2.2 / 25     | 5        | 10 / 16       |
| 24  | 1 / 50       | 9        | 2.2 / 16      |
| --  | --           | 12       | 2.2 / 16      |
| --  | --           | 15       | 1 / 25        |

## EMC RECOMMENDED CIRCUITS

Figure 3

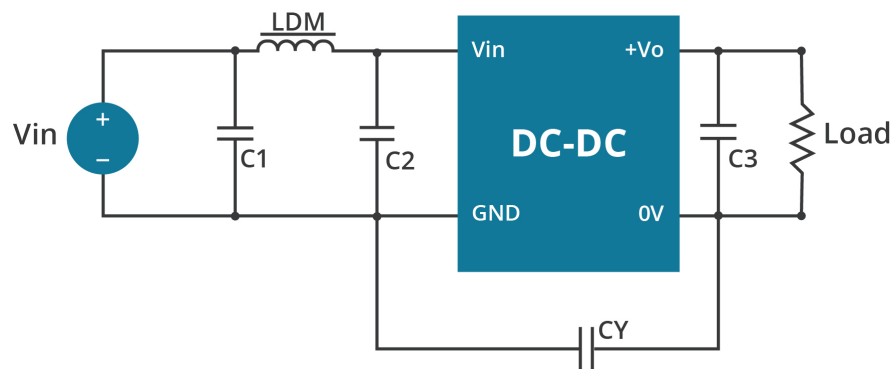

Table 1

| Recommended EMC Filter Values |            |            |             |                     |       |
|-------------------------------|------------|------------|-------------|---------------------|-------|
| Model                         | C1         | C2         | CY          | C3                  | LDM   |
| PRMCE1-S5-S3-S                | 4.7μF /25V | 4.7μF /25V | --          | see Cout in table 1 | 6.8μH |
| PRMCE1-S5-S5-S                | 4.7μF /25V | 4.7μF /25V | --          | see Cout in table 1 | 6.8μH |
| PRMCE1-S5-S9-S                | 4.7μF /25V | 4.7μF /25V | --          | see Cout in table 1 | 6.8μH |
| PRMCE1-S5-S12-S               | 4.7μF /25V | 4.7μF /25V | 1nF/4KVDC   | see Cout in table 1 | 6.8μH |
| PRMCE1-S5-S15-S               | 4.7μF /25V | 4.7μF /25V | 1nF/4KVDC   | see Cout in table 1 | 6.8μH |
| PRMCE1-S5-S24-S               | 4.7μF /25V | 4.7μF /25V | 1nF/4KVDC   | see Cout in table 1 | 6.8μH |
| all other models              | 4.7μF /50V | 4.7μF /50V | 270pF/3KVDC | see Cout in table 1 | 6.8μH |

## REVISION HISTORY

| rev. | description                                | date       |
|------|--|------------|
| 1.0  | initial release                            | 03/09/2020 |
| 1.01 | derating curve and circuit figures updated | 07/06/2021 |
| 1.02 | datasheet updated                          | 09/16/2021 |
| 1.03 | datasheet updated                          | 10/06/2021 |
| 1.04 | CE certification updated                   | 11/29/2022 |
| 1.05 | min output current value added             | 10/18/2023 |

The revision history provided is for informational purposes only and is believed to be accurate.



**Headquarters**  
20050 SW 112th Ave.  
Tualatin, OR 97062  
**800.275.4899**

Fax 503.612.2383  
**cui.com**  
techsupport@cui.com

CUI offers a two (2) year limited warranty. Complete warranty information is listed on our website.

CUI reserves the right to make changes to the product at any time without notice. Information provided by CUI is believed to be accurate and reliable. However, no responsibility is assumed by CUI for its use, nor for any infringements of patents or other rights of third parties which may result from its use.

CUI products are not authorized or warranted for use as critical components in equipment that requires an extremely high level of reliability. A critical component is any component of a life support device or system whose failure to perform can be reasonably expected to cause the failure of the life support device or system, or to affect its safety or effectiveness.

## Looking for pricing, stock, or lifecycle information?

Click below to explore more details on WIN SOURCE:

 [View PRMCE1-S5-S3-S on WIN SOURCE](#)

 [CUI Inc. Information](#)

## Optimize Your Supply Chain with WIN SOURCE Solutions

-  Global Sourcing Solution
-  Obsolete Management
-  Cost Control Management
-  Shortage Management
-  Alternative Solution
-  Excess Inventory Management