



**THE DATASHEET OF
HTSS-136-01-L-D-01**



NOTES:

- ⊕ REPRESENTS A CRITICAL DIMENSION.
- ASSEMBLE GOLD PLATED END AS SHOWN.
- TERMINAL PUSHOUT FORCE: 2 LBS BEFORE HEAT.
- TERMINALS TO BE FLUSH TO .010[.25] BELOW TOP OF SHROUD.
- MATES ONLY WITH SSW, SSQ, SSM, BCS, ESW, ESQ.
- TUBES ARE STANDARD PACKAGING.
- ORDERS WILL BE PACKAGED ACCORDING TO THE SAMTEC PACKAGING EFFICIENCY STANDARDS (SPES) FOUND ON WWW.SAMTEC.COM
- ATTACH LABEL -4X2 TO EACH REEL

POSITIONS	COPLANARITY
-02 THRU -15	.0040[.102]
-16 THRU -36	.0060[.152]

HTSS-1XX-01-XX-DV-X-XX-X-XX

No OF POSITIONS

-02 THRU -36
(PER ROW)

LEAD STYLE

-01: SURFACE MOUNT
(USE T-1S6-08-XX-2)

PLATING SPECIFICATION

- T: MATTE TIN ON CONTACT AND TAIL
- S: 30μ" SELECTIVE GOLD IN CONTACT AREA, MATTE TIN ON TAIL
- L: 10μ" SELECTIVE GOLD IN CONTACT AREA, MATTE TIN ON TAIL
- H: 30μ" HEAVY GOLD IN CONTACT AREA, 3μ" ON TAIL
- TM: MATTE TIN ON CONTACT AREA AND TAIL
- SM: 30μ" SELECTIVE GOLD IN CONTACT AREA, MATTE TIN ON TAIL
- LM: 10μ" LIGHT SELECTIVE IN CONTACT AREA, MATTE TIN ON TAIL
- SS: 30μ" STRIP SELECTIVE ON CONTACT, MATTE TIN ON TAIL (SEE NOTE 5).

PACKAGING (SEE NOTE 7 & 8)
BLANK: TUBES (SEE NOTE 6)
-TR: TAPE & REEL
(POSITIONS -02 THRU -25 ONLY)
-FR: FULL REEL QTY TAPE & REEL
(POSITIONS -02 THRU -25 ONLY)

-P: PICK & PLACE PAD
(USE PPP-22)

POLARIZATION OPTION

-XX: INDICATES POSITION OMITTED

-A: ALIGNMENT PIN (* ASO OPTION)
(FIG 3 SHT 2)

ROW SPECIFICATION

-DV: DOUBLE VERTICAL
(USE HTSS-XX-D)

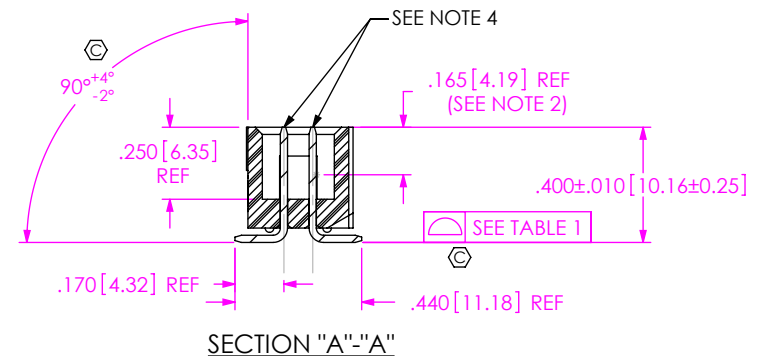
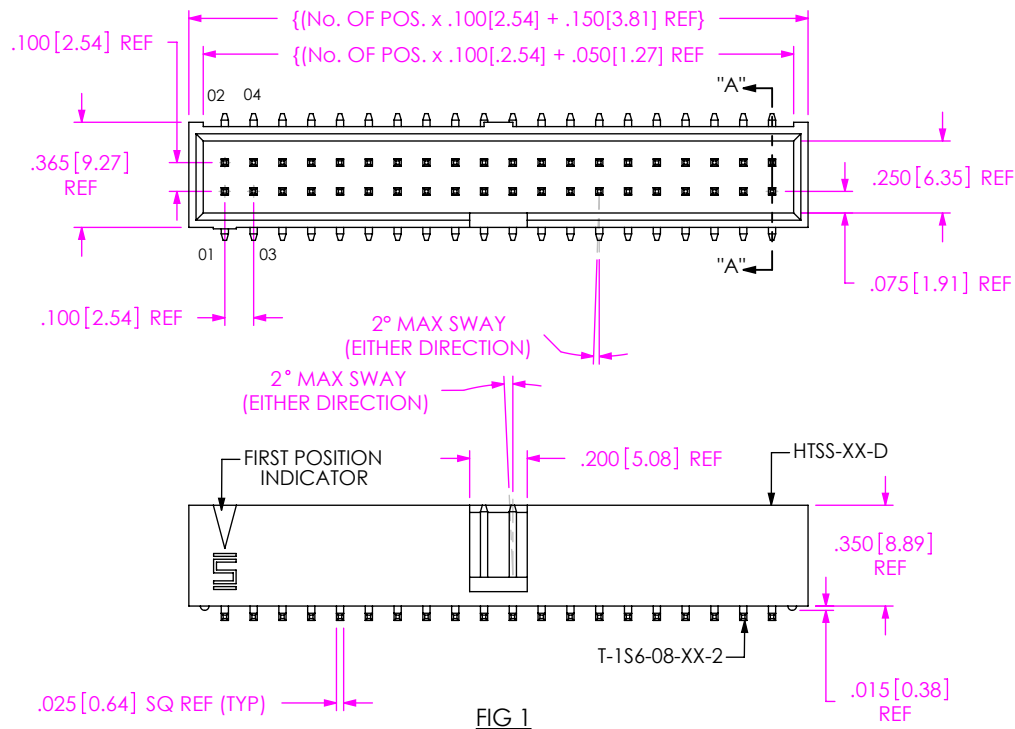
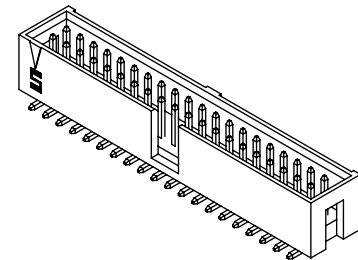

IN-PROCESS 1

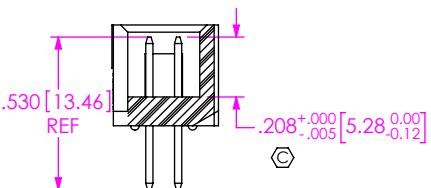

IN-PROCESS 2

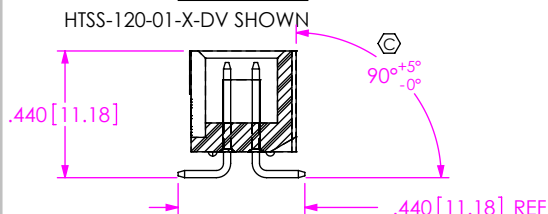

UNLESS OTHERWISE SPECIFIED, DIMENSIONS ARE IN INCHES.

TOLERANCES ARE:

DECIMALS ANGLES
.XX: ±.01 [.3] 2°
.XXX: ±.005 [.13]
.XXXX: ±.0020 [.051]

PROPRIETARY NOTE

THIS DOCUMENT CONTAINS INFORMATION CONFIDENTIAL AND PROPRIETARY TO SAMTEC, INC. AND SHALL NOT BE REPRODUCED OR TRANSFERRED TO OTHER DOCUMENTS OR DISCLOSED TO OTHERS OR USED FOR ANY PURPOSE OTHER THAN THAT WHICH IT WAS OBTAINED WITHOUT THE EXPRESSED WRITTEN CONSENT OF SAMTEC, INC.

MATERIAL: DO NOT SCALE DRAWING SHEET SCALE: 1:0.666667

INSULATOR:
LCP, UL 94 VO
COLOR: NATURAL

TERMINAL: PHOS BRONZE

F:\DWG\MISC\MKTG\HTSS-1XX-01-XX-DV-X-XX-X-XX-MKT.SLDDRW



520 PARK EAST BLVD, NEW ALBANY, IN 47150
PHONE: 812-944-6733 FAX: 812-948-5047
e-Mail: info@SAMTEC.com code: 55322

DESCRIPTION: HIGH TEMP TOP SHROUD

DWG. NO. HTSS-1XX-01-XX-DV-X-XX-X-XX

BY: T. WERNE 07/14/2001 SHEET 1 OF 2

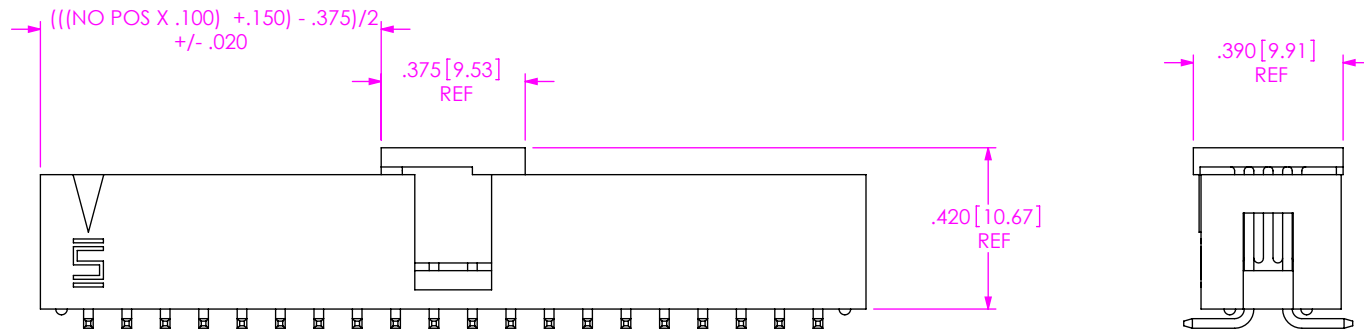

FIG 2
 -P: PICK & PLACE PAD OPTION
 (SAME AS FIG. 1 UNLESS OTHERWISE STATED)

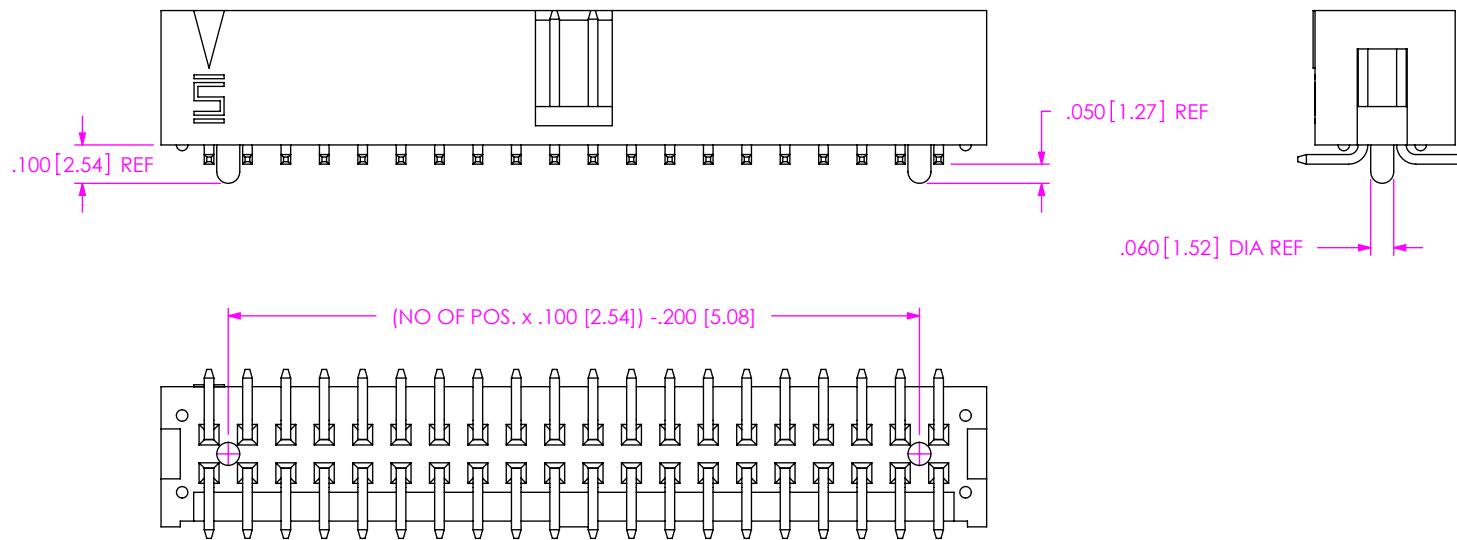
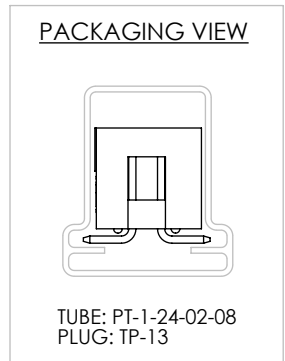



FIG 3
 -A: ALIGNMENT PIN OPTION
 (SAME AS FIG. 1 UNLESS OTHERWISE STATED)



<p>PROPRIETARY NOTE THIS DOCUMENT CONTAINS INFORMATION CONFIDENTIAL AND PROPRIETARY TO SAMTEC, INC. AND SHALL NOT BE REPRODUCED OR DISCLOSED TO OTHERS OR USED FOR ANY PURPOSE OTHER THAN THAT WHICH IT WAS OBTAINED WITHOUT THE EXPRESSED WRITTEN CONSENT OF SAMTEC, INC.</p> <p>DO NOT SCALE DRAWING</p> <p>SHEET SCALE: 1.5:1</p>		
	<p>520 PARK EAST BLVD., NEW ALBANY, IN 47150 PHONE: 812-944-6733 FAX: 812-948-5047 e-Mail: info@SAMTEC.com code: 55322</p>	
	<p>DESCRIPTION: HIGH TEMP TOP SHROUD</p>	
	<p>DWG. NO. HTSS-1XX-01-XX-DV-X-XX-X-XX</p>	
<p>BY: T. WERNE 07/14/2001</p>		<p>SHEET 2 OF 2</p>

Looking for pricing, stock, or lifecycle information?

Click below to explore more details on WIN SOURCE:

-  [View HTSS-136-01-L-D-01 on WIN SOURCE](#)
-  [Samtec Inc. Information](#)

Optimize Your Supply Chain with WIN SOURCE Solutions

-  Global Sourcing Solution
-  Obsolete Management
-  Cost Control Management
-  Shortage Management
-  Alternative Solution
-  Excess Inventory Management