

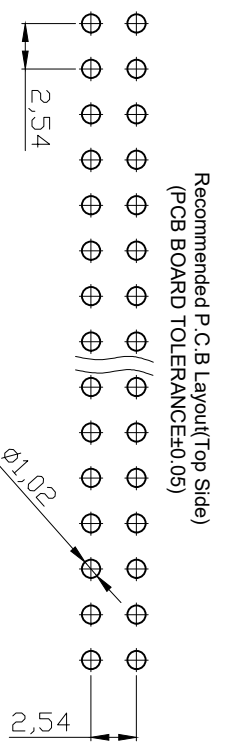

**THE DATASHEET OF
AWHW14G-0202-T-R**

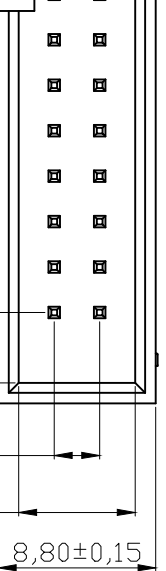

3	4	5	6	7
---	---	---	---	---



Recommended P.C.B Layout(Top Side)
(PCB BOARD TOLERANCE±0.05)

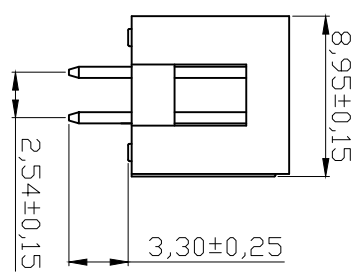
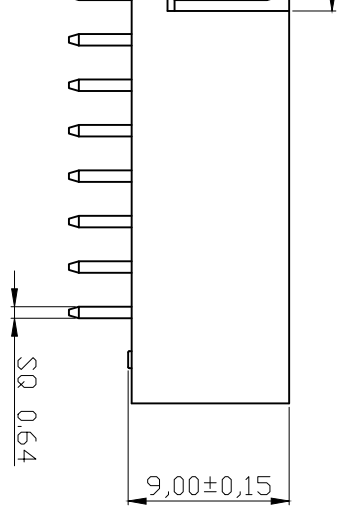
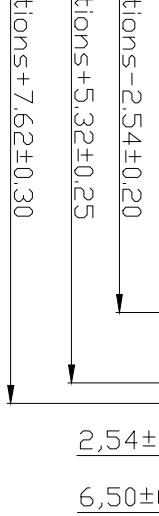

NOTES:

MATERIAL

- 1. Insulator Material: PBT+30%GF(UL94V-0),Grey
- 2.Contact Material : Brass
- 3.Contact Plating : AWHHW xxG-0202-T: Gold flash/Tin Over Ni

- ⑨ AWHHW xxG-0102-T: 30u"Au/Tin Over Ni
- AWHHW xxG-0302-T: 15u"Au/Tin Over Ni
- AWHHW xxG-0402-T: 10u"Au/Tin Over Ni

- ⑤ ELECTRICAL

- 1.Current Rating: 3AMP
 - 2.Voltage Rating: 250V
 - ⑩ 3.Withstand Voltage: 1000V AC/Minute
 - 4.Contact Resistance : 20mΩ max
 - 5.Insulation Resistance: 1000MΩ min
- ENVIRONMENTAL
- 1.Operation T temperature: -40°C to +105°C
 - 2.Packing: Tray packing

Order information:
xx : 06,08,10,12,14,16,18,20,24
26,30,34,40,50,60,64

Dimension anithesses list	
NO. Pin	L
6P-8P	4.00
10P-64P	4.40

Free	Update the notes	03.03.2022	Daniel		Date	Name		Customer-No.	ASSMANN WSW-No. AWHHW xxG-0X02-T
TOLERANCE	Add the plating 10u" and 15u" Au	23.09.2021	Peter	Drawn	25.01.2006	Alex			
±0.40	Add P/N and sheet 2	05.07.2021	Daniel	Approved	03.03.2022	Daniel			
±0.25	Add solder profile	10.03.2021	Daniel						
±0.15	Cancel solder profile	12.10.2020	Daniel						
TOL ±3°	Add voltage rating	09.07.2019	Xavier						
⑤	Id.	Modification	Date	Name			Drawing-No.	ASS 2314 CO	rev10
3	4	5	6	7	Replace	Sheet 1/3			

SV3409

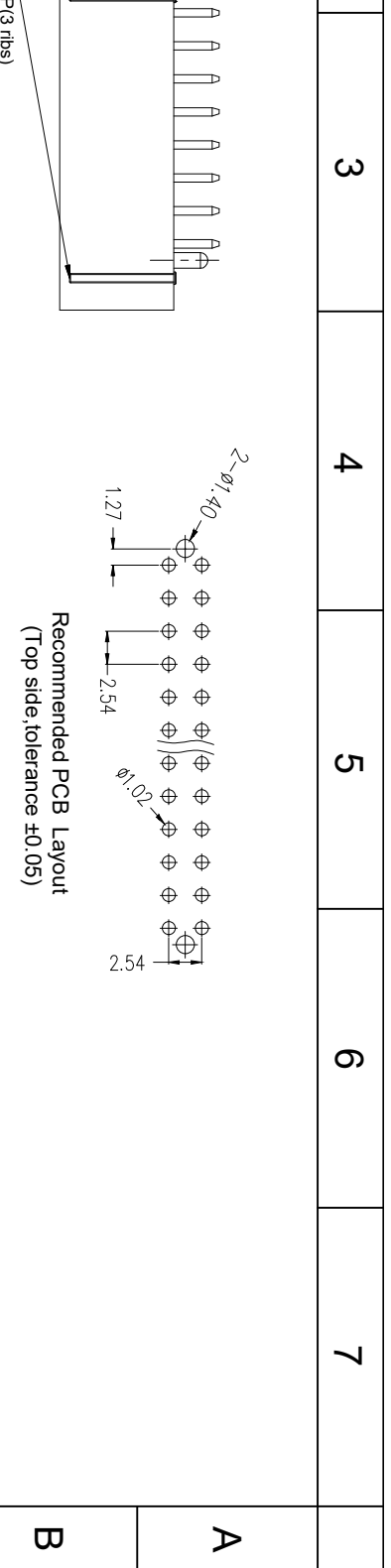

Recommended PCB Layout
(Top side, tolerance ±0.05)

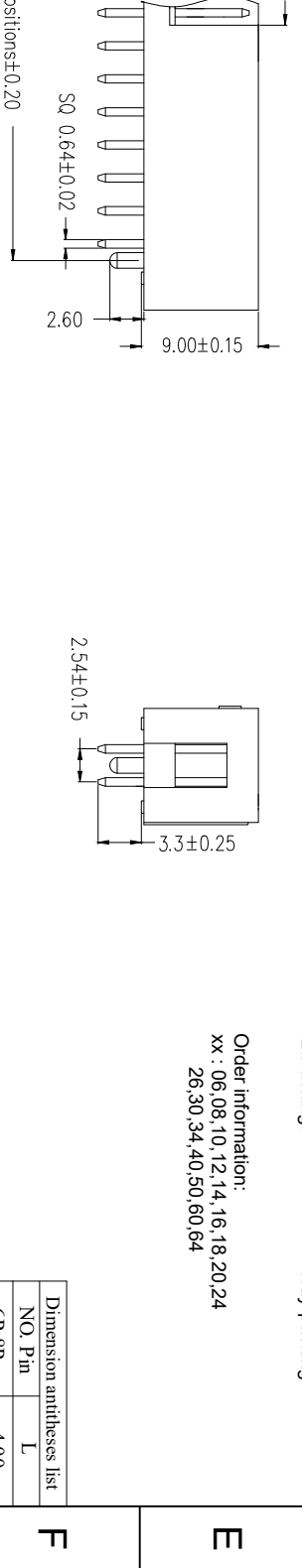
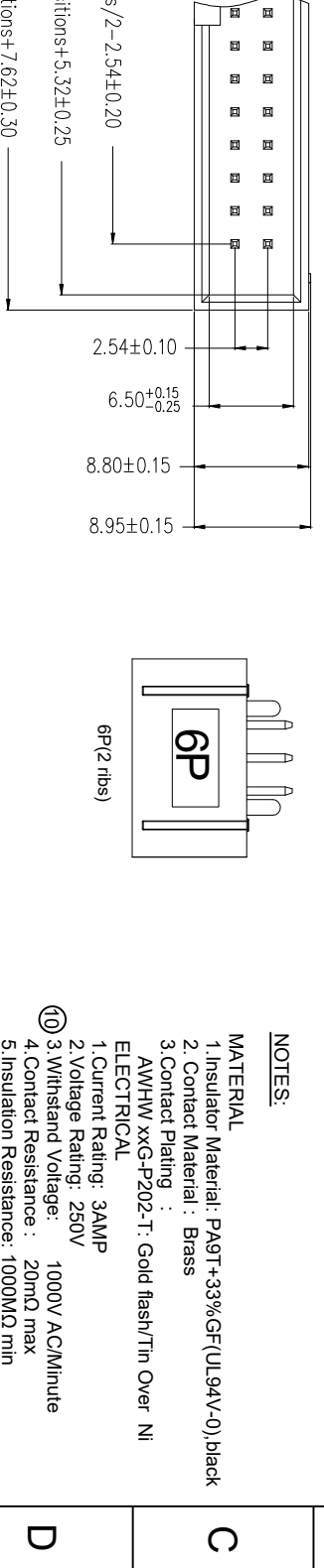

- NOTES:**
- MATERIAL**
1. Insulator Material: PA9T+33%GF(UL94V-0),black
 2. Contact Material : Brass
 3. Contact Plating : AWHW xxG-P202-T: Gold flash/Tin Over Ni ELECTRICAL
 1. Current Rating: 3AMP
 2. Voltage Rating: 250V
 3. Withstand Voltage: 1000V AC/Minute
 4. Contact Resistance : 20mΩ max
 5. Insulation Resistance: 1000MΩ min
- ENVIRONMENTAL**
1. Operation Temperature: -40°C to +105°C
 2. Packing: Tray packing

Order information:
xx : 06,08,10,12,14,16,18,20,24
26,30,34,40,50,60,64

Dimension antitheses list	
NO. Pin	L
6P-8P	4,00
10P-64P	4,40

Free	⑩	Update the notes	Daniel	Date	Name	Customer-No.	ASSMANN WSW-No.	⑧ AWHW xxG-PX02-T	Drawing-No.	Sheet
ANCE	⑨	Add the plating 10u" and 15u" Au	Peter	23.09.2021	Alex				ASS 2314 CO	rev10
±0.40	⑧	Add P/N and sheet 2	Daniel	05.07.2021	Daniel					
±0.25	⑦	Add solder profile	Daniel	10.03.2021						
±0.15	⑥	Cancel solder profile	Daniel	12.10.2020						
TOL	⑤	Add voltage rating	Xavier	09.07.2019						
±3°	Id.	Modification	Name	Date	Name					



3	4	5	6	7

A	B	C	D	E	F	G	H

SV3409

Looking for pricing, stock, or lifecycle information?

Click below to explore more details on WIN SOURCE:

- ⊖ [View AWHW14G-0202-T-R on WIN SOURCE](#)
- ⊖ [Assmann WSW Components](#) Information

Optimize Your Supply Chain with WIN SOURCE Solutions

- ✓ Global Sourcing Solution
- ✓ Obsolete Management
- ✓ Cost Control Management
- ✓ Shortage Management
- ✓ Alternative Solution
- ✓ Excess Inventory Management