



**THE DATASHEET OF
RTE0T0002LKCE00000R**



E2 emulator Lite RTE0T0002LKCE00000R User's Manual

All information contained in these materials, including products and product specifications, represents information on the product at the time of publication and is subject to change by Renesas Electronics Corporation without notice. Please review the latest information published by Renesas Electronics Corporation through various means, including the Renesas Electronics Corporation website (<http://www.renesas.com>).

Notice

1. Descriptions of circuits, software and other related information in this document are provided only to illustrate the operation of semiconductor products and application examples. You are fully responsible for the incorporation or any other use of the circuits, software, and information in the design of your product or system. Renesas Electronics disclaims any and all liability for any losses and damages incurred by you or third parties arising from the use of these circuits, software, or information.
2. Renesas Electronics hereby expressly disclaims any warranties against and liability for infringement or any other claims involving patents, copyrights, or other intellectual property rights of third parties, by or arising from the use of Renesas Electronics products or technical information described in this document, including but not limited to, the product data, drawings, charts, programs, algorithms, and application examples.
3. No license, express, implied or otherwise, is granted hereby under any patents, copyrights or other intellectual property rights of Renesas Electronics or others.
4. You shall be responsible for determining what licenses are required from any third parties, and obtaining such licenses for the lawful import, export, manufacture, sales, utilization, distribution or other disposal of any products incorporating Renesas Electronics products, if required.
5. You shall not alter, modify, copy, or reverse engineer any Renesas Electronics product, whether in whole or in part. Renesas Electronics disclaims any and all liability for any losses or damages incurred by you or third parties arising from such alteration, modification, copying or reverse engineering.
6. Renesas Electronics products are classified according to the following two quality grades: "Standard" and "High Quality". The intended applications for each Renesas Electronics product depends on the product's quality grade, as indicated below.

"Standard": Computers; office equipment; communications equipment; test and measurement equipment; audio and visual equipment; home electronic appliances; machine tools; personal electronic equipment; industrial robots; etc.

"High Quality": Transportation equipment (automobiles, trains, ships, etc.); traffic control (traffic lights); large-scale communication equipment; key financial terminal systems; safety control equipment; etc.

Unless expressly designated as a high reliability product or a product for harsh environments in a Renesas Electronics data sheet or other Renesas Electronics document, Renesas Electronics products are not intended or authorized for use in products or systems that may pose a direct threat to human life or bodily injury (artificial life support devices or systems; surgical implantations; etc.), or may cause serious property damage (space system; undersea repeaters; nuclear power control systems; aircraft control systems; key plant systems; military equipment; etc.). Renesas Electronics disclaims any and all liability for any damages or losses incurred by you or any third parties arising from the use of any Renesas Electronics product that is inconsistent with any Renesas Electronics data sheet, user's manual or other Renesas Electronics document.

7. No semiconductor product is absolutely secure. Notwithstanding any security measures or features that may be implemented in Renesas Electronics hardware or software products, Renesas Electronics shall have absolutely no liability arising out of any vulnerability or security breach, including but not limited to any unauthorized access to or use of a Renesas Electronics product or a system that uses a Renesas Electronics product. RENESAS ELECTRONICS DOES NOT WARRANT OR GUARANTEE THAT RENESAS ELECTRONICS PRODUCTS, OR ANY SYSTEMS CREATED USING RENESAS ELECTRONICS PRODUCTS WILL BE INVULNERABLE OR FREE FROM CORRUPTION, ATTACK, VIRUSES, INTERFERENCE, HACKING, DATA LOSS OR THEFT, OR OTHER SECURITY INTRUSION ("Vulnerability Issues"). RENESAS ELECTRONICS DISCLAIMS ANY AND ALL RESPONSIBILITY OR LIABILITY ARISING FROM OR RELATED TO ANY VULNERABILITY ISSUES. FURTHERMORE, TO THE EXTENT PERMITTED BY APPLICABLE LAW, RENESAS ELECTRONICS DISCLAIMS ANY AND ALL WARRANTIES, EXPRESS OR IMPLIED, WITH RESPECT TO THIS DOCUMENT AND ANY RELATED OR ACCOMPANYING SOFTWARE OR HARDWARE, INCLUDING BUT NOT LIMITED TO THE IMPLIED WARRANTIES OF MERCHANTABILITY, OR FITNESS FOR A PARTICULAR PURPOSE.
8. When using Renesas Electronics products, refer to the latest product information (data sheets, user's manuals, application notes, "General Notes for Handling and Using Semiconductor Devices" in the reliability handbook, etc.), and ensure that usage conditions are within the ranges specified by Renesas Electronics with respect to maximum ratings, operating power supply voltage range, heat dissipation characteristics, installation, etc. Renesas Electronics disclaims any and all liability for any malfunctions, failure or accident arising out of the use of Renesas Electronics products outside of such specified ranges.
9. Although Renesas Electronics endeavors to improve the quality and reliability of Renesas Electronics products, semiconductor products have specific characteristics, such as the occurrence of failure at a certain rate and malfunctions under certain use conditions. Unless designated as a high reliability product or a product for harsh environments in a Renesas Electronics data sheet or other Renesas Electronics document, Renesas Electronics products are not subject to radiation resistance design. You are responsible for implementing safety measures to guard against the possibility of bodily injury, injury or damage caused by fire, and/or danger to the public in the event of a failure or malfunction of Renesas Electronics products, such as safety design for hardware and software, including but not limited to redundancy, fire control and malfunction prevention, appropriate treatment for aging degradation or any other appropriate measures. Because the evaluation of microcomputer software alone is very difficult and impractical, you are responsible for evaluating the safety of the final products or systems manufactured by you.
10. Please contact a Renesas Electronics sales office for details as to environmental matters such as the environmental compatibility of each Renesas Electronics product. You are responsible for carefully and sufficiently investigating applicable laws and regulations that regulate the inclusion or use of controlled substances, including without limitation, the EU RoHS Directive, and using Renesas Electronics products in compliance with all these applicable laws and regulations. Renesas Electronics disclaims any and all liability for damages or losses occurring as a result of your noncompliance with applicable laws and regulations.
11. Renesas Electronics products and technologies shall not be used for or incorporated into any products or systems whose manufacture, use, or sale is prohibited under any applicable domestic or foreign laws or regulations. You shall comply with any applicable export control laws and regulations promulgated and administered by the governments of any countries asserting jurisdiction over the parties or transactions.
12. It is the responsibility of the buyer or distributor of Renesas Electronics products, or any other party who distributes, disposes of, or otherwise sells or transfers the product to a third party, to notify such third party in advance of the contents and conditions set forth in this document.
13. This document shall not be reprinted, reproduced or duplicated in any form, in whole or in part, without prior written consent of Renesas Electronics.
14. Please contact a Renesas Electronics sales office if you have any questions regarding the information contained in this document or Renesas Electronics products.

(Note1) "Renesas Electronics" as used in this document means Renesas Electronics Corporation and also includes its directly or indirectly controlled subsidiaries.

(Note2) "Renesas Electronics product(s)" means any product developed or manufactured by or for Renesas Electronics.

(Rev.5.0-1 October 2020)

Corporate Headquarters

TOYOSU FORESIA, 3-2-24 Toyosu,
Koto-ku, Tokyo 135-0061, Japan
www.renesas.com

Trademarks

Renesas and the Renesas logo are trademarks of Renesas Electronics Corporation. All trademarks and registered trademarks are the property of their respective owners.

Contact Information

For further information on a product, technology, the most up-to-date version of a document, or your nearest sales office, please visit:
www.renesas.com/contact/

General Precautions in the Handling of Microprocessing Unit and Microcontroller Unit Products

The following usage notes are applicable to all Microprocessing unit and Microcontroller unit products from Renesas. For detailed usage notes on the products covered by this document, refer to the relevant sections of the document as well as any technical updates that have been issued for the products.

1. Precaution against Electrostatic Discharge (ESD)

A strong electrical field, when exposed to a CMOS device, can cause destruction of the gate oxide and ultimately degrade the device operation. Steps must be taken to stop the generation of static electricity as much as possible, and quickly dissipate it when it occurs. Environmental control must be adequate. When it is dry, a humidifier should be used. This is recommended to avoid using insulators that can easily build up static electricity. Semiconductor devices must be stored and transported in an anti-static container, static shielding bag or conductive material. All test and measurement tools including work benches and floors must be grounded. The operator must also be grounded using a wrist strap. Semiconductor devices must not be touched with bare hands. Similar precautions must be taken for printed circuit boards with mounted semiconductor devices.

2. Processing at power-on

The state of the product is undefined at the time when power is supplied. The states of internal circuits in the LSI are indeterminate and the states of register settings and pins are undefined at the time when power is supplied. In a finished product where the reset signal is applied to the external reset pin, the states of pins are not guaranteed from the time when power is supplied until the reset process is completed. In a similar way, the states of pins in a product that is reset by an on-chip power-on reset function are not guaranteed from the time when power is supplied until the power reaches the level at which resetting is specified.

3. Input of signal during power-off state

Do not input signals or an I/O pull-up power supply while the device is powered off. The current injection that results from input of such a signal or I/O pull-up power supply may cause malfunction and the abnormal current that passes in the device at this time may cause degradation of internal elements. Follow the guideline for input signal during power-off state as described in your product documentation.

4. Handling of unused pins

Handle unused pins in accordance with the directions given under handling of unused pins in the manual. The input pins of CMOS products are generally in the high-impedance state. In operation with an unused pin in the open-circuit state, extra electromagnetic noise is induced in the vicinity of the LSI, an associated shoot-through current flows internally, and malfunctions occur due to the false recognition of the pin state as an input signal become possible.

5. Clock signals

After applying a reset, only release the reset line after the operating clock signal becomes stable. When switching the clock signal during program execution, wait until the target clock signal is stabilized. When the clock signal is generated with an external resonator or from an external oscillator during a reset, ensure that the reset line is only released after full stabilization of the clock signal. Additionally, when switching to a clock signal produced with an external resonator or by an external oscillator while program execution is in progress, wait until the target clock signal is stable.

6. Voltage application waveform at input pin

Waveform distortion due to input noise or a reflected wave may cause malfunction. If the input of the CMOS device stays in the area between V_{IL} (Max.) and V_{IH} (Min.) due to noise, for example, the device may malfunction. Take care to prevent chattering noise from entering the device when the input level is fixed, and also in the transition period when the input level passes through the area between V_{IL} (Max.) and V_{IH} (Min.).

7. Prohibition of access to reserved addresses

Access to reserved addresses is prohibited. The reserved addresses are provided for possible future expansion of functions. Do not access these addresses as the correct operation of the LSI is not guaranteed.

8. Differences between products

Before changing from one product to another, for example to a product with a different part number, confirm that the change will not lead to problems. The characteristics of a microprocessing unit or microcontroller unit products in the same group but having a different part number might differ in terms of internal memory capacity, layout pattern, and other factors, which can affect the ranges of electrical characteristics, such as characteristic values, operating margins, immunity to noise, and amount of radiated noise. When changing to a product with a different part number, implement a system-evaluation test for the given product.

Preface

The E2 emulator Lite (RTE0T00020LKCE00000R; hereafter referred to as the E2 Lite) is designed for use with the devices made by Renesas Electronics.

All components of the E2 Lite are listed under “1.1 Package Components”. If you have any questions about the E2 Lite, contact your local distributor.

Documentation for the E2 Lite manual is in two parts. In using the E2 Lite, please be sure to read each of them.

- The E2 emulator Lite user’s manual (this manual)
- The additional documents for user’s manual for E1/E20 emulator or E2 emulator Lite

This user’s manual describes mainly the hardware specifications of the E2 Lite. For information on emulator debuggers and other related products, please see the additional document for user’s manuals included with each product.

You can download the latest manuals from the Renesas Tools homepage.

<https://www.renesas.com/e2lite>

Important

Before using the emulator, be sure to read this user's manual carefully.

Keep this user's manual, and refer to it when you have questions about the emulator.

Emulator:

"Emulator" in this user's manual collectively refers to the E2 Lite manufactured by Renesas Electronics Corporation.

"Emulator" herein encompasses neither the customer's user system nor the host machine.

Purpose of use of the emulator:

This emulator is a device to support the development of systems that uses the Renesas microcomputers. It provides support for system development in both software and hardware. By using in combination with a programming software, it is available as a flash programming tool.

Be sure to use the emulator correctly according to said purpose of use. Please avoid using the emulator other than for its intended purpose of use.

For those who use the emulator:

The emulator can only be used by those who have carefully read the user's manual and know how to use it.

Use of the emulator requires basic knowledge of electric circuits, logical circuits, and MCUs.

When using the emulator:

- (1) The emulator is a development-support unit for use in your program development and evaluation stages. When a program you have finished developing is to be incorporated in a mass-produced product, the judgment as to whether it can be put to practical use is entirely your own responsibility, and should be based on evaluation of the device on which it is installed and other experiments.
- (2) In no event shall Renesas Electronics Corporation be liable for any consequence arising from the use of the emulator.
- (3) Renesas Electronics Corporation strives to provide workarounds for and correct trouble with products malfunctions, with some free and some incurring charges. However, this does not necessarily mean that Renesas Electronics Corporation guarantees the provision of a workaround or correction under any circumstances.
- (4) The emulator covered by this document has been developed on the assumption that it will be used for program development and evaluation in laboratories. Therefore, it does not fall within the scope of applicability of the Electrical Appliance and Material Safety Law and protection against electromagnetic interference when used in Japan.
- (5) Renesas Electronics Corporation cannot predict all possible situations and possible cases of misuse that carry a potential for danger. Therefore, the warnings in this user's manual and the warning labels attached to the emulator do not necessarily cover all such possible situations and cases. The customer is responsible for correctly and safely using the emulator.

- (6) This emulator has acquired the standards shown in "1.5 Regulatory Compliance Notices". This fact must be taken into account when the emulator is taken from Japan to some other country.
- (7) Renesas Electronics Corporation will not assume responsibility of direct or indirect damage caused by an accidental failure or malfunction in the emulator.

When disposing the emulator:

Penalties may be applicable for incorrect disposal of this waste, in accordance with your national legislation.

Usage restrictions:

The emulator has been developed as a means of supporting system development by users. Therefore, do not use it as an embedded device in other equipment. Also, do not use it to develop systems or equipment for use in the following fields.

- (1) Transportation and vehicular
- (2) Medical (equipment that has an involvement in human life)
- (3) Aerospace
- (4) Nuclear power control
- (5) Undersea repeaters

If you are considering the use of the emulator for one of the above purposes, please be sure to consult your local distributor.

About product changes:

We are constantly making efforts to improve the design and performance of our product. Therefore, the specification or design of the emulator, or this user's manual, may be changed without prior notice.

About rights:

- (1) We assume no responsibility for any damage or infringement on patent rights or any other rights arising from the use of any information, products or circuits presented in this user's manual.
- (2) The information or data in this user's manual does not implicitly or otherwise grant a license to patent rights or any other rights belonging to Renesas or to a third party.
- (3) This user's manual and the emulator are copyrighted, with all rights reserved by Renesas. This user's manual may not be copied, duplicated or reproduced, in whole or part, without prior written consent from Renesas.

About diagrams:

Some diagrams in this user's manual may differ from the objects they represent.

Precautions for Safety

This chapter, by showing the relevant diagrammatic symbols and their meanings, describes the precautions which should be taken in order to use this product safely and properly. Be sure to read and understand this chapter before using this product.

Contact us if you have any questions about the precautions described here.



WARNING indicates a potentially dangerous situation that will cause death or heavy wound unless it is avoided.



CAUTION indicates a potentially dangerous situation that will cause a slight injury or a medium-degree injury or property damage unless it is avoided.

To avoid a possible danger, the following diagrammatic symbols are used to call your attention.

△ means WARNING or CAUTION.

Example:



CAUTION AGAINST AN ELECTRIC SHOCK

⊘ means PROHIBITION.

Example:



DISASSEMBLY PROHIBITED

● means A FORCIBLE ACTION.

Example:



UNPLUG THE POWER CABLE FROM THE RECEPTACLE.

 **WARNING****Warnings for AC Power Supply:**

Do not repair or remodel the emulator product by yourself in order to prevent danger such as an electric shock or fire and for the sake of quality assurance. For after-sale services in case of a mechanical or electrical fault, please contact your local distributor.

Always switch off the Host machine and user system before connecting or disconnecting any cables or parts. Neglect of this precaution will result in getting an electric shock or will result in the emulator product or user system emitting smoke or catching fire. Also, the user program under debug will be destroyed.

Make sure that the connectors on both ends of the user-system interface cable are facing the right way relative to the user-side connector on the emulator and the connector on the user system, respectively.

Neglect of this precaution will result in getting an electric shock or will result in the emulator product or user system emitting smoke or catching fire.

Warning for Modification:

Do not modify the emulator. Personal injury due to electric shock may occur if the emulator is modified. Modifying the product will void your warranty.

Warning for Installation:

Do not set the emulator in water or areas of high humidity. Make sure that the product does not get wet. Spilling water or some other liquid into the product may cause un-repairable damage.

Warning for Use temperature:

The emulator is to be used in an environment with a maximum ambient temperature of 35°C. Care should be taken that this temperature is not exceeded.

 **CAUTION****Caution to Be Taken for Handling the Emulator:**

Exercise caution when handling the emulator. Be careful not to apply a mechanical shock.

Do not touch the connector pins of the emulator and the target MCU connector pins directly. Static electricity may damage the internal circuits.

When attaching and removing the cable, hold the plug of the cable and do not touch the cable.

When installing the emulator, do not flex the cable excessively or pull the emulator or the board by the cable connected to it. The cable may cause a break.

Do not tape the flexible cable or apply adhesives to secure the cable. The shielding material on the surface of the cable may come off.

Caution to Be Taken for System Malfunctions:

If the emulator malfunctions because of interference like external noise, do the following to remedy the trouble.

(1) Exit the emulator debugger, and shut OFF the emulator and the user system.

(2) After a lapse of 10 seconds, turn ON the power of the emulator and the user system again, then launch the emulator debugger.

Caution to Be Taken for Disposal:

Penalties may be applicable for incorrect disposal of this waste, in accordance with your national legislation.

European Union regulatory notices:

The WEEE (Waste Electrical and Electronic Equipment) regulations put responsibilities on producers for the collection and recycling or disposal of electrical and electronic waste. Return of WEEE under these regulations is applicable in the European Union only. This equipment (including all accessories) is not intended for household use. After use the equipment cannot be disposed of as household waste, and the WEEE must be treated, recycled and disposed of in an environmentally sound manner.

■ Renesas Electronics Europe GmbH can take back end of life equipment, register for this service at "<http://www.renesas.eu/weee>"

Contents

| | Page |
|---|-----------|
| Preface | 3 |
| Important..... | 4 |
| Precautions for Safety..... | 6 |
| Contents | 9 |
| Terminology | 10 |
| 1. Outline | 11 |
| 1.1 Package Components..... | 11 |
| 1.2 System Configuration..... | 12 |
| 1.3 PC Interface | 12 |
| 1.4 Specifications..... | 13 |
| 1.5 Regulatory Compliance Notices | 14 |
| 1.5.1 European Union regulatory notices..... | 14 |
| 1.5.2 United States regulatory notices | 14 |
| 1.6 E2 Lite Hardware Configuration..... | 15 |
| 1.7 Names of the Emulator Parts..... | 16 |
| 1.8 Operating Environment..... | 18 |
| 2. Setup | 19 |
| 2.1 Installing Emulator Software..... | 19 |
| 2.2 Connecting the E2 Lite to the Host Machine | 19 |
| 2.3 Connecting the E2 Lite to the User System..... | 20 |
| 2.4 Turning the Power On/Off..... | 23 |
| 2.4.1 When a Separate Power Supply is Used for the User System..... | 23 |
| 2.4.2 When Power is Supplied to the User System from the Emulator | 24 |
| 2.5 Connecting System Ground..... | 25 |
| 2.6 Hot plug-in..... | 26 |
| 3. Troubleshooting (Action in Case of an Error)..... | 27 |
| 3.1 How to Solve a Trouble..... | 27 |
| 3.1.1 The ACTIVE LED does not flash or light up..... | 27 |
| 3.1.2 Unconnectable with the debugger | 27 |
| 3.2 How to Request Support..... | 27 |
| 4. Maintenance and Warranty..... | 28 |
| 4.1 Maintenance | 28 |
| 4.2 Warranty | 28 |
| Appendix A E2 Lite Self-Checking Program (SCP)..... | 29 |
| A.1 Flow of Self-Checking | 29 |
| A.2 Preparations for Self-Checking | 29 |
| A.3 Executing the SCP | 30 |
| Revision History..... | 35 |

Terminology

Some specific words used in this user's manual are defined below.

Integrated development environment

This tool provides powerful support for the development of embedded applications for Renesas microcomputers. It has an emulator debugger function allowing the emulator to be controlled from the host machine via an interface. Furthermore, it permits a range of operations from editing a project to building and debugging it to be performed within the same application. In addition, it supports version management.

Emulator debugger

This means a software tool that is started up from the integrated development environment, and controls the emulator and enables debugging.

Programming software

This means Renesas Flash Programmer that is available on the emulator.

Host machine

This means a personal computer used to control the emulator.

Target MCU

This means the MCU to be debugged.

User system

This means a user's application system in which the MCU to be debugged is used.

User program

This means the application program to be debugged.

1. Outline

This chapter describes the package components, the system configuration, and the specifications of the emulator functions and operating environment.

1.1 Package Components

The E2 Lite package consists of the following items. After you have unpacked the box, check if your E2 Lite contains all of these items. Table 1.1 shows the packing components for the E2 Lite.

Table 1.1 Package Components for the E2 Lite

| Item | Description | Quantity |
|------------------------------------|-----------------------------|----------|
| E2 Lite main unit | RTE0T0002LKCE00000R | 1 |
| USB interface cable | A plug — mini-B plug, 1.0 m | 1 |
| 14-pin user-system interface cable | 14-pin flat cable, 15 cm | 1 |

1.2 System Configuration

The E2 Lite is used by connecting it to the target MCU mounted on the user system.

Figure 1.1 shows the configuration of the E2 Lite system.

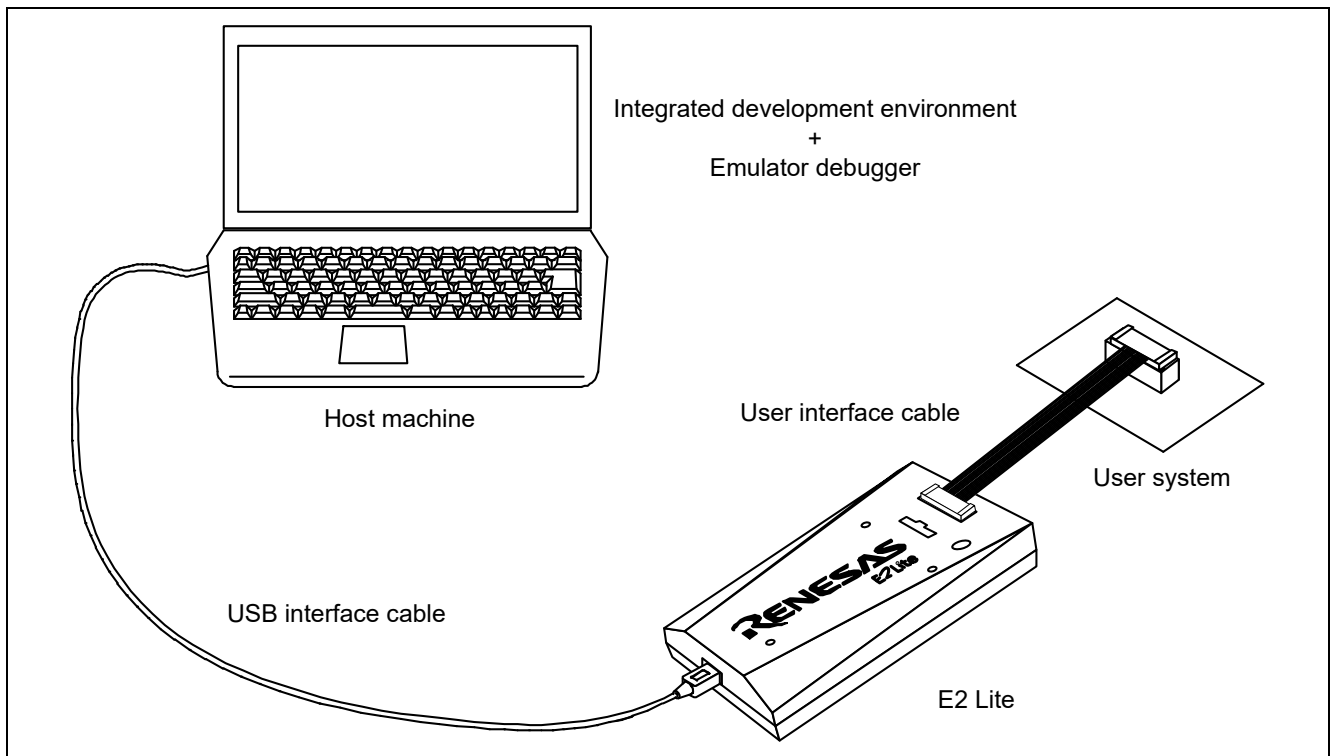

Figure 1.1 System Configuration of the E2 Lite

- (1) E2 Lite (this product)
- (2) USB interface cable (included)
- (3) 14-pin user-system interface cable (included)
 - 20-pin to 20-pin user-system interface cable; type name: RTE0T00020KCAC0000J (separately available)
 - 20-pin to 10-pin user-system interface cable; type name: RTE0T00020KCAC1000J (separately available)
- (4) User system
 - This is your application system on which the MCU for debugging is mounted.
- (5) Host machine
 - A personal computer to control the emulator by USB interface.

1.3 PC Interface

- USB Interface*
 - USB 2.0 full speed (also connectable to USB 1.1- and USB 3.0-compatible host machines)

Note: Operation with all combinations of host machine, USB device, and USB hub is not guaranteed.

1.4 Specifications

Table 1.2 lists the specifications of the E2 Lite.

Table 1.2 Specifications of the E2 Lite

| Item | Description |
|--|---|
| Emulator type | E2 emulator Lite Type name: RTE0T0002LKCE00000R |
| PC interface | USB 2.0 (full speed) |
| Target interface | 14-pin (2.54-mm pitch) connector 20-pin (1.27-mm pitch) connector 10-pin (1.27-mm pitch) connector |
| Power voltage for the emulator | USB-bus power supply (VBUS 4.5 V min. / 500 mA max.) |
| Power supply for the target MCU | Supplied from the user system or the emulator (3.3 V: 200 mA max.*) |
| Supported voltages for the user system | Within 1.8 V to 5.5 V, and in the range of the MCU's power supply voltage while in operation. For more information, see the additional document for user's manual for the E1/E20 emulator or E2 emulator Lite. |
| External dimension (main body) | 96.2 mm × 52.7 mm × 17.2 mm |
| Weight | 47 g |
| Operating temperature | 5 to 35°C (no condensation) |
| Storage temperature | -10 to 60°C (no condensation) |
| EMC | EU: EN 55032 Class A, EN 55024 USA: FCC part 15 Class A |

Note: When 500 mA is supplied from USB VBUS

1.5 Regulatory Compliance Notices

1.5.1 European Union regulatory notices

This product complies with the following EU Directives. (These directives are only valid in the European Union.)

CE Certifications:

- Electromagnetic Compatibility (EMC) Directive 2014/30/EU
EN 55032 Class A

WARNING: This is a Class A product. This equipment can cause radio frequency noise when used in the residential area. In such cases, the user/operator of the equipment may be required to take appropriate countermeasures under his responsibility.

EN 55024

- Information for traceability
 - Authorized representative & Manufacturer
Name: Renesas Electronics Corporation
Address: TOYOSU FORESIA, 3-2-24, Toyosu, Koto-ku, Tokyo 135-0061, Japan
 - Person responsible for placing on the market
Name: Renesas Electronics Europe GmbH
Address: Arcadiastrasse 10, 40472 Dusseldorf, Germany
 - Trademark and Type name
Trademark: Renesas
Product name: E2 Lite
Type name: RTE0T0002LKCE00000R

Environmental Compliance and Certifications:

- Waste Electrical and Electronic Equipment (WEEE) Directive 2012/19/EU

1.5.2 United States regulatory notices

This product complies with the following EMC regulation. (This is only valid in the United States.)

FCC Certifications:

This equipment has been tested and found to comply with the limits for a Class A digital device, pursuant to Part 15 of the FCC Rules. These limits are designed to provide reasonable protection against harmful interference when the equipment is operated in a commercial environment. This equipment generates, uses, and can radiate radio frequency energy and, if not installed and used in accordance with the instruction manual, may cause harmful interference to radio communications. Operation of this equipment in a residential area is likely to cause harmful interference in which case the user will be required to correct the interference at his own expense.

This device complies with Part 15 of the FCC Rules. Operation is subject to the following two conditions: (1) this device may not cause harmful interference, and (2) this device must accept any interference received, including interference that may cause undesired operation.

CAUTION: Changes or modifications not expressly approved by the party responsible for compliance could void the user's authority to operate the equipment.

1.6 E2 Lite Hardware Configuration

As shown in Figure 1.2, the E2 Lite consists of the E2 Lite main unit, a USB interface cable, and a user-system interface cable. The emulator is connectable to the host machine via a USB port compliant with USB 2.0 (Full-Speed) or USB 1.1.

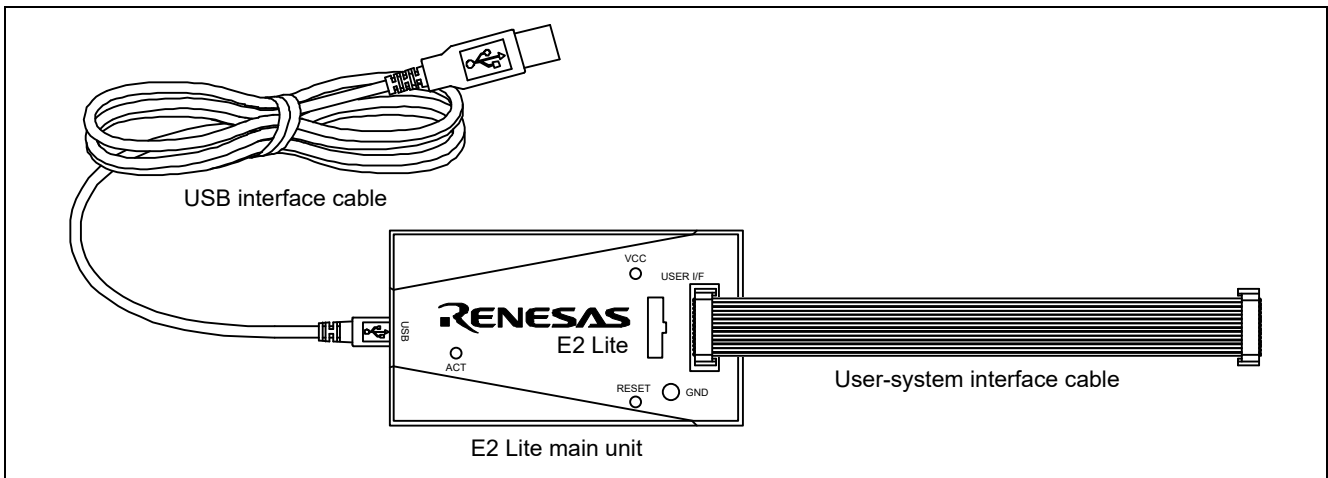

Figure 1.2 E2 Lite Hardware Configuration

1.7 Names of the Emulator Parts

The names of the parts of the E2 Lite are given in Figure 1.3 to Figure 1.5.

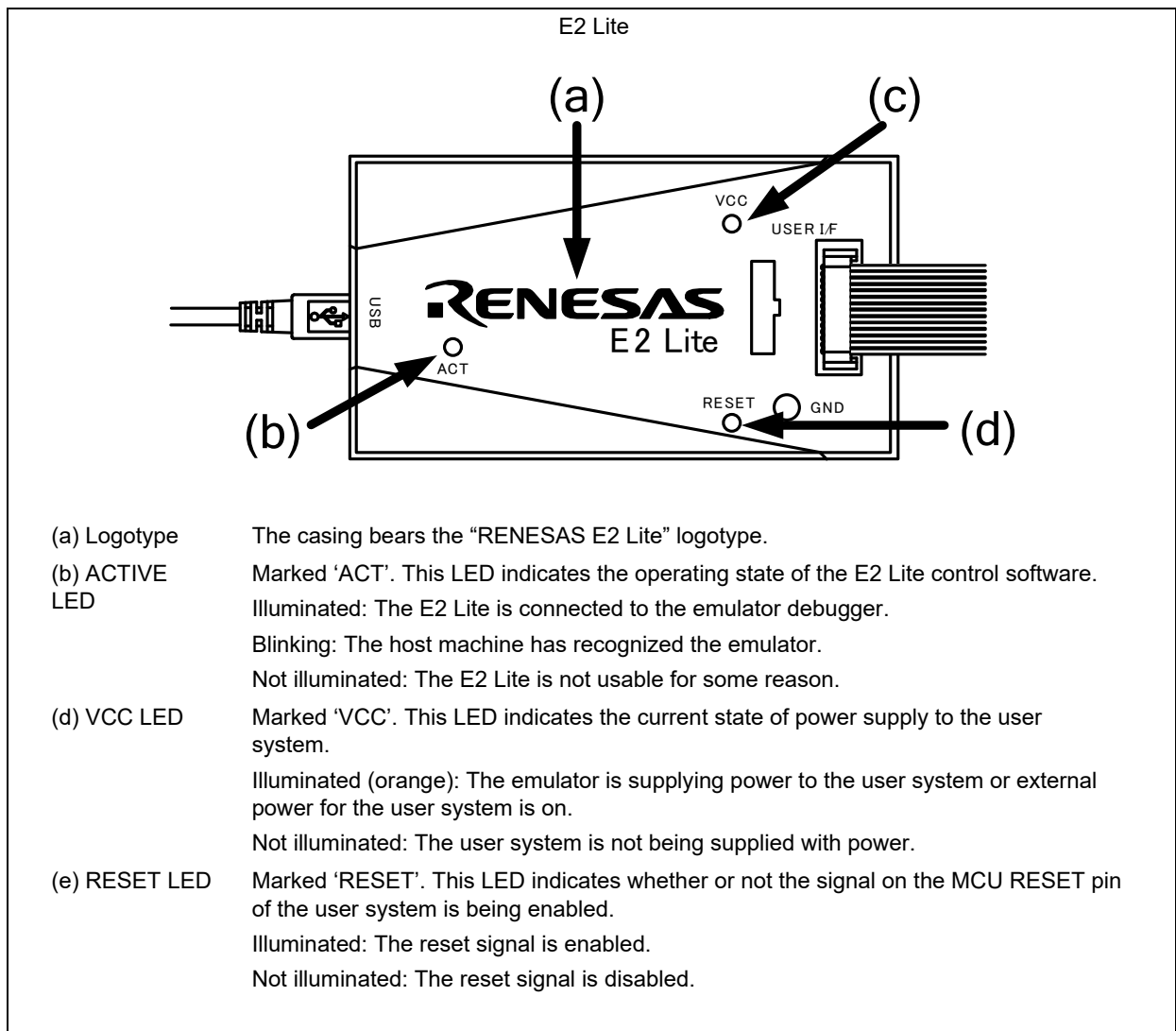

Figure 1.3 E2 Lite Top View

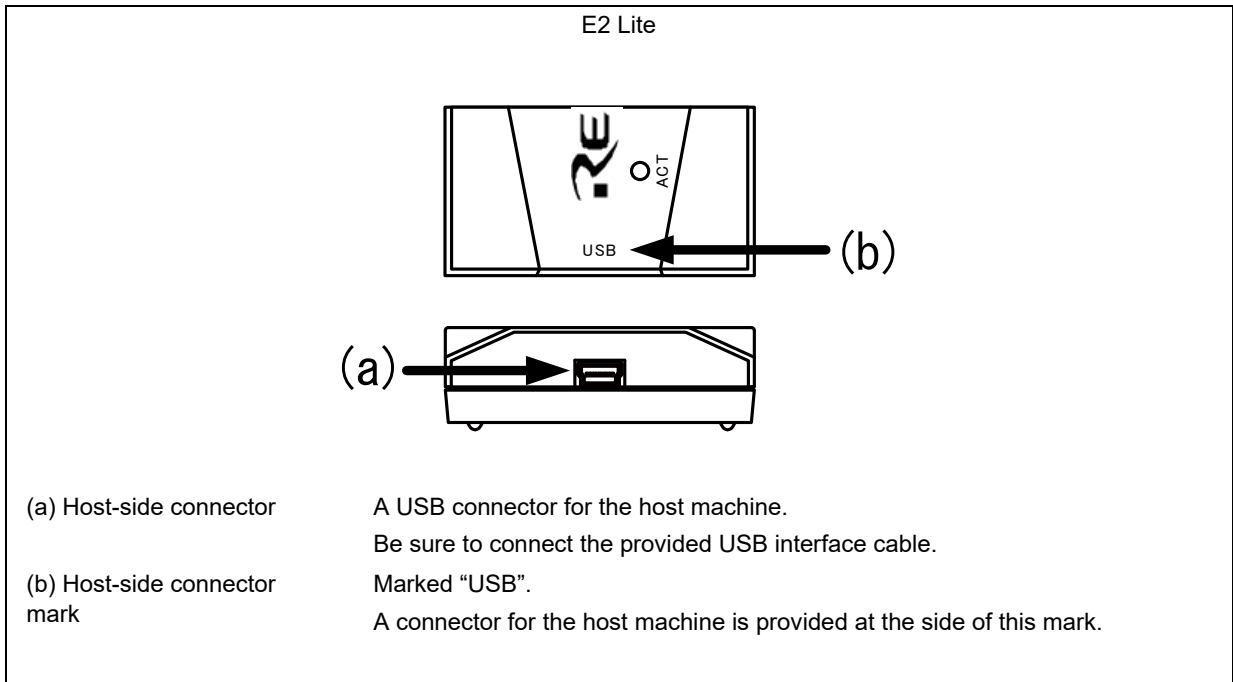

Figure 1.4 E2 Lite Host-Side View

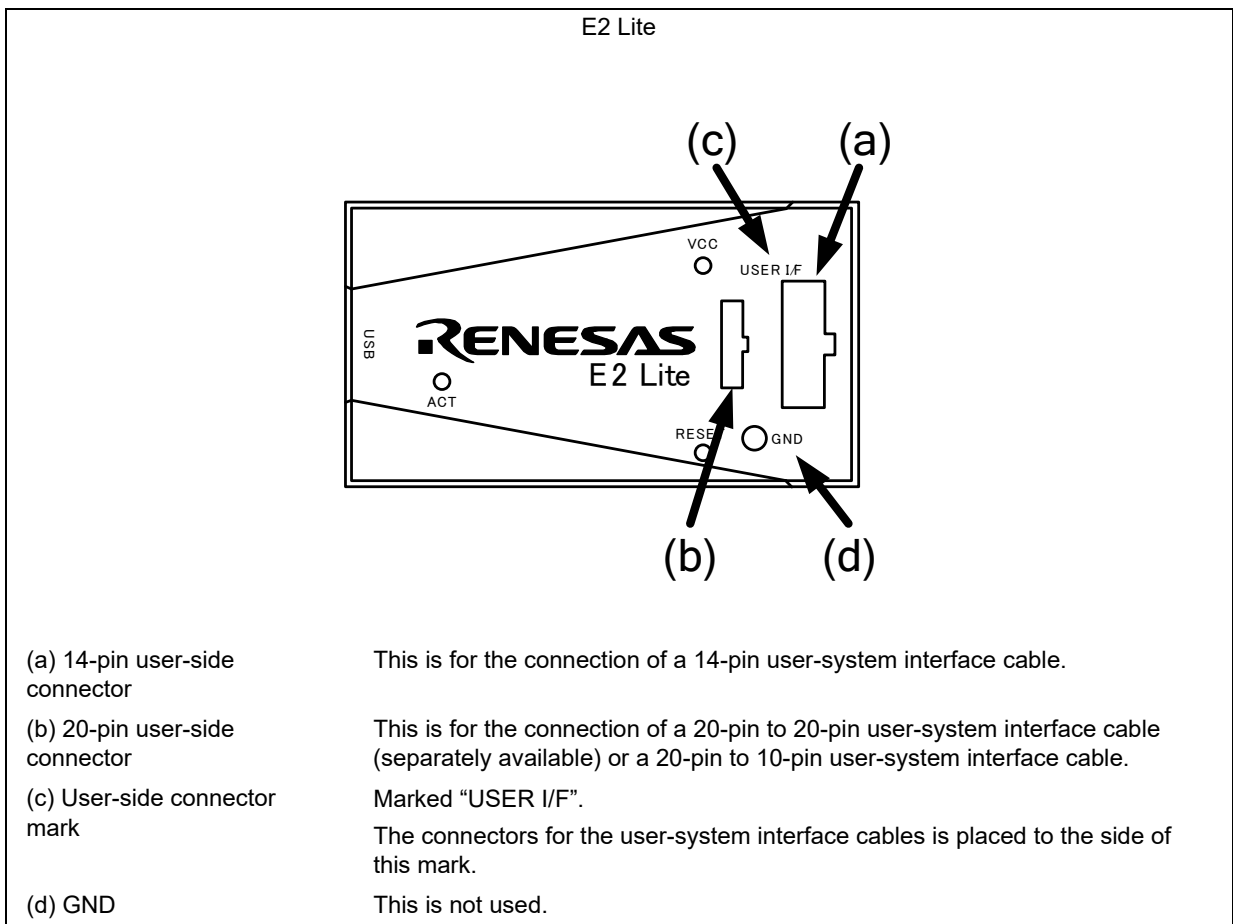

Figure 1.5 E2 Lite User-Side Top View

1.8 Operating Environment

Observe the conditions listed in Table 1.3 when using the emulator.

Table 1.3 Operating Environmental Conditions

| Item | Description |
|---------------|---|
| Temperature | Operating: +5°C to +35°C Storage: -10°C to +60°C |
| Humidity | 35% RH to 80% RH, no condensation |
| Vibration | Operating: 2.45 m/s ² max. Storage: 4.9 m/s ² max. Transportation: 14.7 m/s ² max. |
| Ambient gases | No corrosive gases may be present. |

2. Setup

2.1 Installing Emulator Software

If you are using the E2 Lite, download and install the latest integrated development environment or flash memory programming software from the following Web site.

https://www.renesas.com/e2lite_download

2.2 Connecting the E2 Lite to the Host Machine

Use the USB interface cable supplied with the product to connect the E2 Lite to the host machine as shown in Figure 2.1.

For the position of each connector of the E2 Lite, refer to section 1.7, Names of the Emulator Parts.

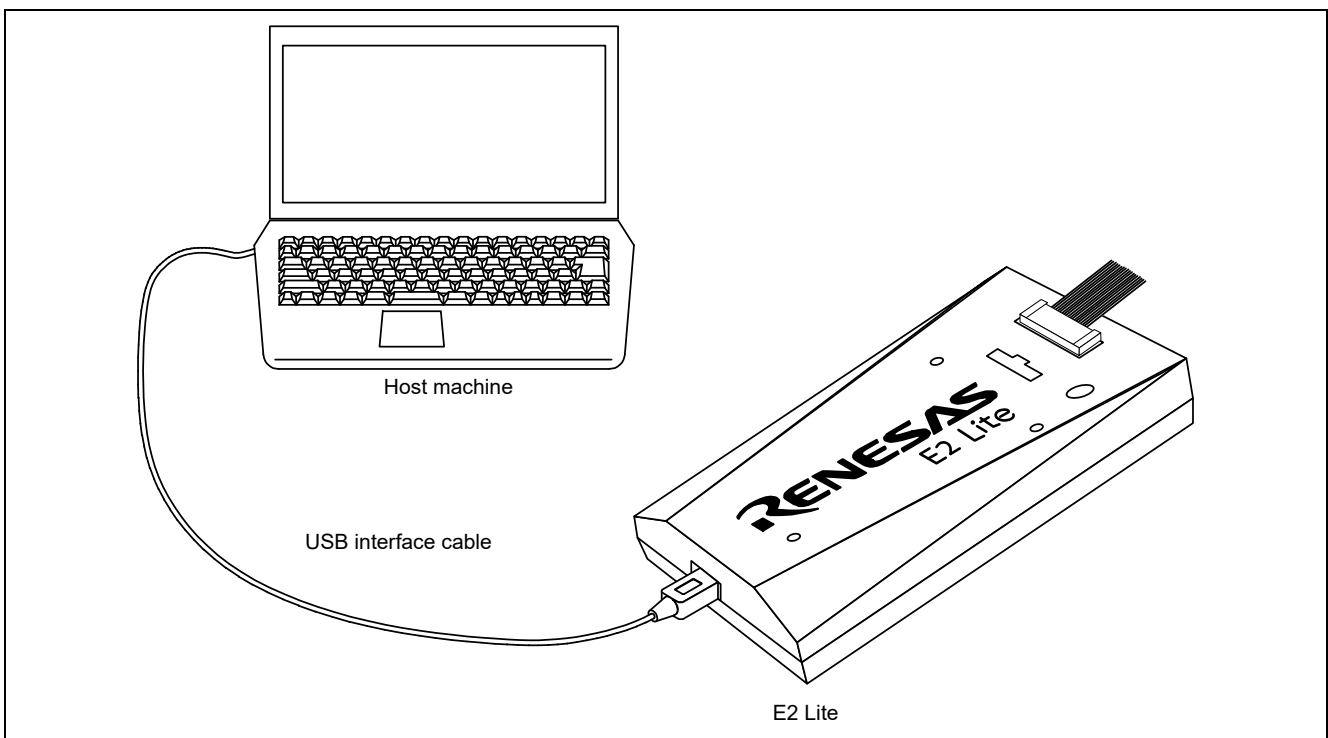

Figure 2.1 System Configuration when Connecting the E2 Lite to the Host Machine

- (1) Connect the A plug of the USB interface cable to the USB interface connector of the host machine.
- (2) Connect the mini-B plug of the USB interface cable to the USB interface connector of the E2 Lite.

When you use the E2 Lite, be sure to use the USB interface cable supplied with the product.

The E2 Lite is turned on by connecting the USB interface cable.

Do not connect the E2 Lite to your host machine before having installed the integrated development environment or Flash Programming software you will be using. The USB driver is automatically installed.

If the USB port of the host machine or the emulator to be connected is changed, the USB driver will be re-installed.

2.3 Connecting the E2 Lite to the User System

Use the procedure below to connect the E2 Lite to the user system with the user-system interface cable, or to disconnect them when moving the E2 Lite or the user system.

(1) Connect the user-system interface cable to the user-side connector of the E2 Lite.

When connecting the user-system interface cable to the E2 Lite, check the position of the erroneous insertion prevention key to ensure that the cable is plugged in correctly.

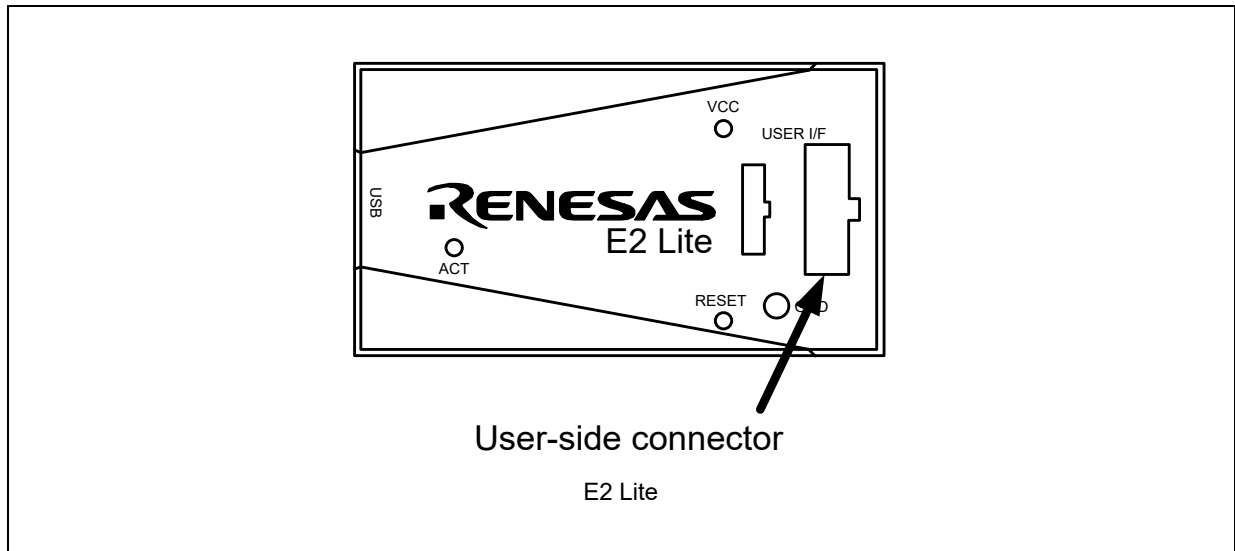

Figure 2.2 User-Side Connector on the E2 Lite

CAUTION

Notes on connector insertion and removal:



When connecting or disconnecting the user-system interface cable and the emulator, grasp the connector at the end of the cable. Pulling the cable itself will damage the wiring.

Also, be aware that the user-system interface cable has the direction in which it must be inserted. If the cable is connected in the wrong direction, it may be damaged.

Correct example

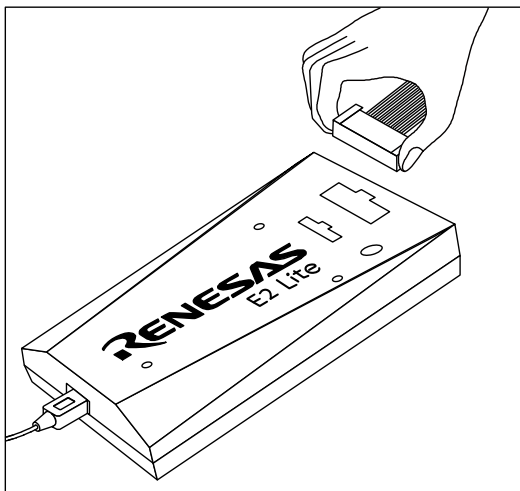

Incorrect example

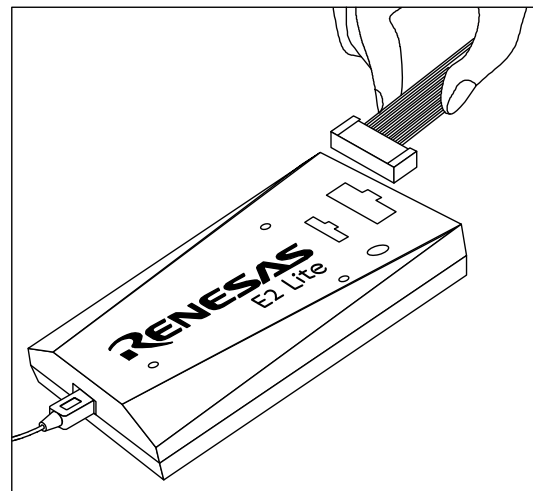

- (2) A connector to the user-system interface cable must be installed on the user system. Table 2.1 shows the recommended connector for the emulator.

Table 2.1 Recommended Connector

| Connector | Type Number | Manufacturer | Specifications |
|----------------------------------|---|------------------|--|
| 14-pin (2.54-mm pitch) connector | 7614-6002 | 3M Japan Limited | 14-pin straight type (Japan) |
| | 2514-6002 | 3M Limited | 14-pin straight type (other countries) |
| 20-pin (1.27-mm pitch) connector | FTSH-110-01-L-DV-K | Samtec | 20-pin surface-mount straight type |
| 10-pin (1.27-mm pitch) connector | FTSH-105-01-L-DV-K | Samtec | 10-pin surface-mount straight type |
| 10-pin (1.27-mm pitch) connector | FTSH-105-01-L-DV* (no guide marking) | Samtec | 10-pin surface-mount straight type |

Note: When using the connector without a guide marking, take care regarding the direction for insertion of the cable.

- (3) For the pin assignments of the connector, refer to the additional document for user's manual for the E1/E20 emulator or E2 emulator Lite which corresponds to the target MCU.
- (4) Connect one end of the user-system interface cable to the E2 Lite and the other end to the connector on the user system as shown in Figure 2.3 and Figure 2.4.

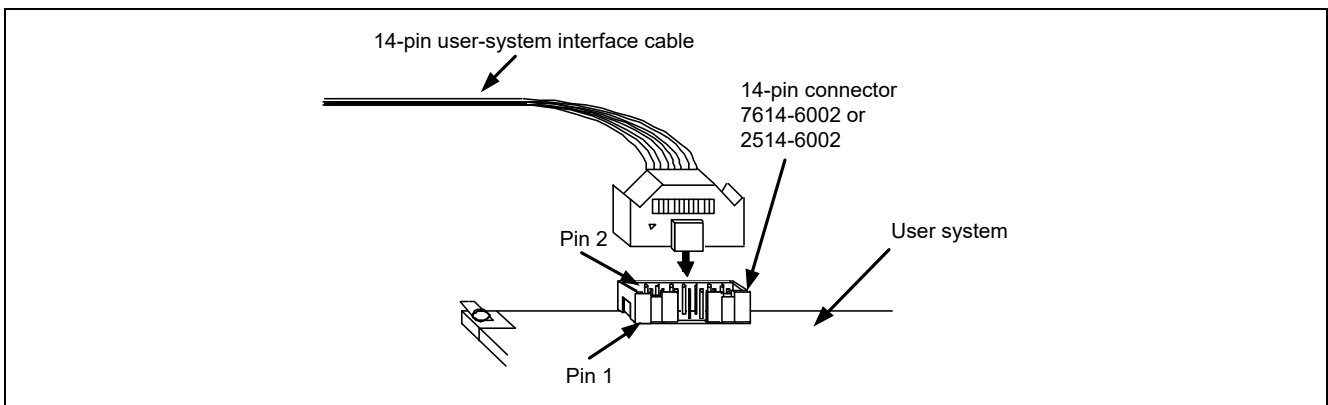

Figure 2.3 Connecting the User-System Interface Cable to the 14-Pin Connector when the E2 Lite is to be Used

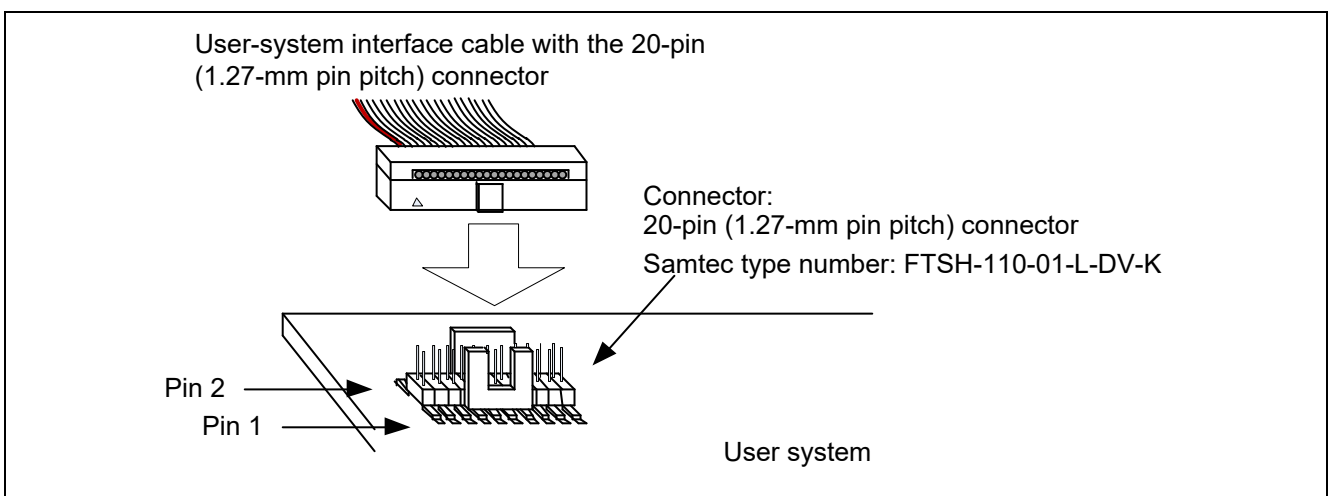

Figure 2.4 Connecting the User-System Interface Cable to the 20-Pin Connector when the E2 Lite is to be Used

CAUTION

Notes on connector insertion and removal:



When connecting or disconnecting the user-system interface cable and the emulator or user system, grasp the connector at the end of the cable. Pulling the cable itself will damage the wiring.

Also, be aware that the user-system interface cable has the direction in which it must be inserted. If the cable is connected in the wrong direction, it may be damaged.

Correct example

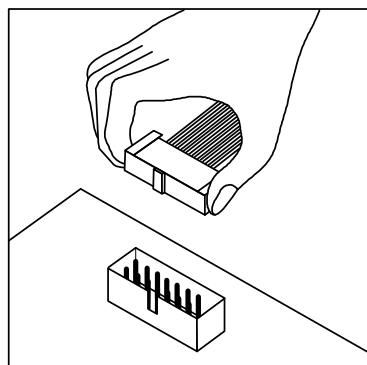

Incorrect example

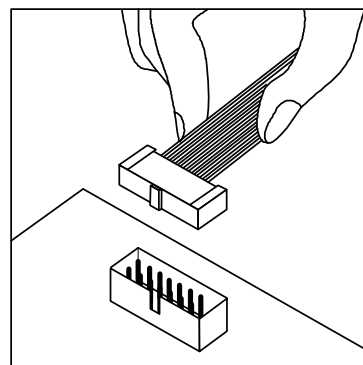

2.4 Turning the Power On/Off

Turn the power of the E2 Lite and the user system following the procedure below.

2.4.1 When a Separate Power Supply is Used for the User System

<When using the emulator>

- (1) Check that the power is off.
Check that the user system is turned off.
- (2) Connect the user system.
Follow the instructions in "2.3 Connecting the E2 Lite to the User System" to connect the emulator and the user system with a user-system interface cable.
- (3) Connect the host machine and turn on the emulator.
Follow the instructions in "2.2 Connecting the E2 Lite to the Host Machine" to connect the emulator and the host machine with a USB interface cable. The E2 Lite is turned on by connecting the USB interface cable.
- (4) Launch the emulator debugger or programming software.
- (5) Turn on the user system.
- (6) Connect the emulator debugger or programming software to the E2 Lite.
The method of connection may differ with the software.

<When finished using the emulator>

- (1) Disconnect the E2 Lite from the emulator debugger or programming software.
Disconnections may differ with the software.
- (2) Turn off the user system.
- (3) Close the emulator debugger or programming software.
- (4) Turn off and disconnect the emulator.
The E2 Lite is turned off by disconnecting from the USB interface cable.
- (5) Disconnect the user system.
Disconnect the user-system interface cable from the user system.



Note on the User System Power Supply:



While the power of the user system is on, do not turn off the host machine or unplug the USB interface cable.

The user system may be damaged due to leakages current.

2.4.2 When Power is Supplied to the User System from the Emulator

<When using the emulator>

(1) Connect the user system.

Follow the instructions in "2.3 Connecting the E2 Lite to the User System" to connect the emulator and the user system with a user-system interface cable.

(2) Connect the host machine and turn on the emulator.

Follow the instructions in "2.2 Connecting the E2 Lite to the Host Machine" to connect the emulator and the user system with a user-system interface cable, then turn on the emulator.

(3) Launch the emulator debugger or programming software and select the setting of power supply to the user system.

(4) Connect the emulator debugger or programming software to the E2 Lite.

Connections may differ with the software.

<When finished using the emulator>

(1) Disconnect the E2 Lite from the emulator debugger or programming software.

Disconnections may differ with the software.

(2) Close the emulator debugger or programming software.

(3) Turn off and disconnect the emulator.

Disconnect the USB interface cable from the emulator, then turn off the emulator.

(4) Disconnect the user-system interface cable from the user system.

2.5 Connecting System Ground

The emulator's signal ground is connected to the user system's signal ground.

In the emulator, the signal ground and frame ground are connected.

In the user system, connect the frame ground only; do not connect the signal ground to the frame ground (Figure 2.5).

If it is difficult to separate the frame ground from the signal ground in the user system, set the GND for DC power input (AC adapter) of the host machine and the frame ground of the user system as the same potential. If the GND potential is different between the host machine and the user system, an overcurrent will flow in the low-impedance GND line and thin lines might be burned.

WARNING

Connecting System Ground :



Separate the frame ground from the signal ground at the user system. Failure to do so will result in smoke, fire, or an electric shock due to the difference in ground potential.

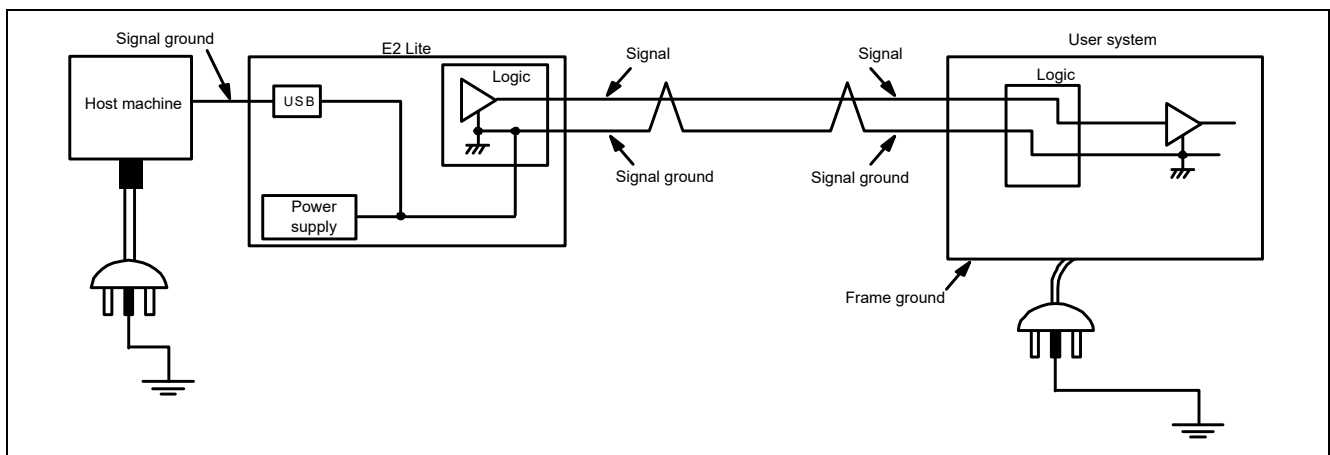

Figure 2.5 Connecting System Ground

For a debugging environment where there is a difference in potential between the GND of the user system and that of the host machine, use the isolator (R0E000010ACB10 or R0E000010ACB20) which is separately available from Renesas.

2.6 Hot plug-in

By using the optional hot-plug adapter for E1 emulators (R0E000010ACB00) which is separately sold, the hot-plug-in function which connects the E2 Lite to the user system is available while the user system is supplied with the power and in operation.

When using the 20-pin connector for connection, connect the GND pin of the 14-pin connector (Figure 2.6, red frame) to the GND of the user system in advance using a lead wire or the like, and then turn on the power to the user system and let it operate so that the hot plug-in function to connect E2 Lite can be used.

For information on the hot plug-in-function, be sure to read the latest version of a user's manual provided for each MCU group.



Figure 2.6 14pin connector GND pin position

3. Troubleshooting (Action in Case of an Error)

3.1 How to Solve a Trouble

The following describes how to solve a trouble when any problem occurs before the emulator debugger starts after power has been supplied to the emulator and the user system. For the latest information on the emulator and emulator debugger, visit Renesas Electronics' development environment Web site (<http://www.renesas.com/tools>).

3.1.1 The ACTIVE LED does not flash or light up

(1) Power is turned off

This means that the E2 Lite is in an unusable state for some reason. Check the following:

- Whether the E2 Lite and the host machine are connected with the USB interface cable.
- Whether the power for the host machine is turned on.

3.1.2 Unconnectable with the debugger

(1) Check the connection between the emulator and the target MCU.

For details, refer to the additional document for user's manual for the E1/E20 emulator or E2 emulator Lite which corresponds to the target MCU.

- Whether the emulator and the target device are connected correctly.
- Whether the connected signal lines are pulled up to the power supply or down to GND properly.

(2) Check to see that the target MCU is in a ready state.

- The operating clock of the target MCU is on (= oscillating).
- The target MCU is supplied with power properly.
- The target MCU has been reset and is ready to go.

3.2 How to Request Support

After checking the items in "Troubleshooting", contact us from the following URL.

<http://www.renesas.com/contact/>

For prompt response, please specify the following information:

(1) Operating environment

- Name of the target device: _____
- Operating frequency: _____ [MHz]
- Operating mode: _____ [Mode]

(2) Condition

- The emulator debugger starts up / does not start up
- Frequency of errors: always / frequency ()

(3) Problem

4. Maintenance and Warranty

This chapter covers basic maintenance, warranty information, provisions for repair and the procedures for requesting a repair.

4.1 Maintenance

- (1) If dust or dirt collects on this product, wipe it off with a dry soft cloth. Do not use thinner or other solvents because these chemicals can cause the surface coating to separate.
- (2) When you do not use this product for a long period, disconnect it from the power supply, host machine and user system.

4.2 Warranty

- (1) We do not provide a repair service for this product. Accordingly, we cannot accept any requests for repairs.
- (2) In the case of replacement due to initial failure, please contact your local distributor within 30 days of the unit's arrival.

CAUTION

Note on Transporting the Product:



When sending your product, use the packing box and cushioning material supplied with the product when it was delivered to you and specify caution in handling (handling as precision equipment). If packing of your product is not complete, it may be damaged during transportation.

Appendix A E2 Lite Self-Checking Program (SCP)

This chapter gives the procedure for using the self-checking program (SCP) for the E2 Lite in fault analysis.

A.1 Flow of Self-Checking

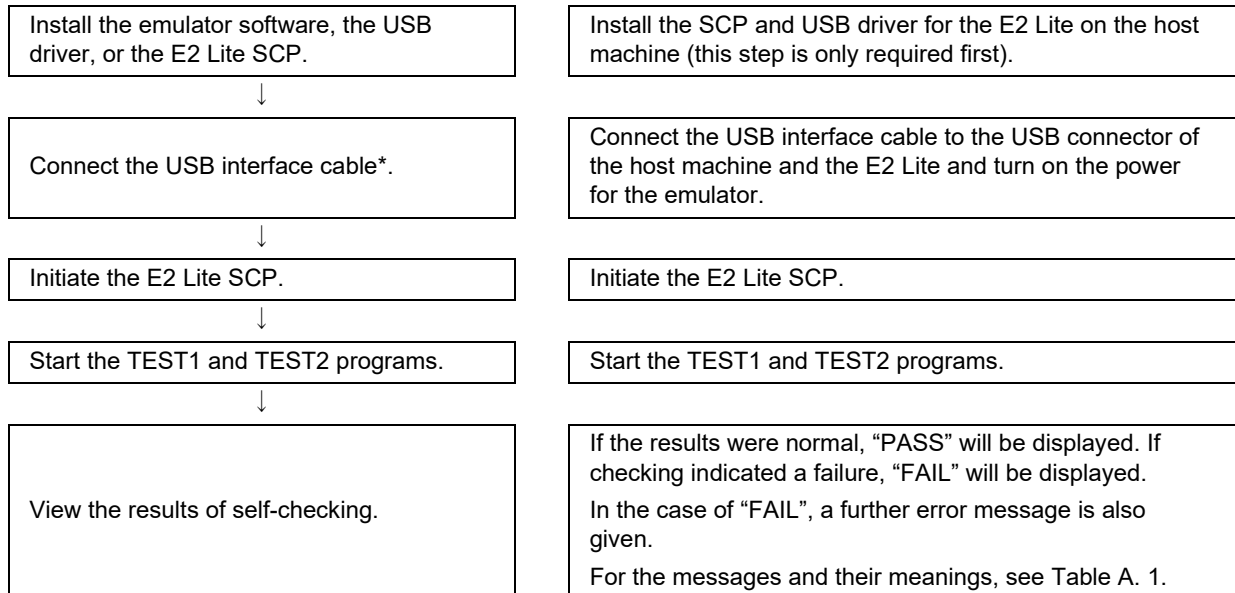

Note: Fault analysis of the hardware by using the E2 Lite SCP only works correctly when a single emulator is connected to the host machine. When two or more emulators are connected, correct operation is not guaranteed.

A.2 Preparations for Self-Checking

(1) The following items are required to execute the E2 Lite SCP.

- E2 Lite main unit
- USB interface cable (included in the package)
- Host machine
- E2 Lite SCP (self-checking program)

Install the E2 Lite SCP to the host machine by installing an integrated development environment from Renesas (e.g. CS+) or downloading the E2 Lite SCP installer from the following Web site.

https://www.renesas.com/e2lite_download

The USB driver is included in the installation of the integrated development environment from Renesas (e.g. CS+ or the e² studio). If you are using an integrated development environment not from Renesas, please contact a Renesas Electronics representative or distributor.

(2) Start up the host machine. Connect the USB interface cable to the USB connector of the host machine and the E2 Lite and turn on the power for the E2 Lite. The user-system interface cable is not used.

A.3 Executing the SCP

(1) Execute the E2 Lite SCP (E2Lite_SCP.exe).

When CS+ has been installed, open the start menu and select [Programs] -> [Renesas Electronics CS+] -> [E2 Lite Self Check Program].

If you are using any other debugger product, install the SCP by using the installer of the SCP that has been downloaded from the E2 Lite downloading site, then open the start menu and select [Programs] -> [Renesas Electronics Utilities] -> [E2 Lite Self Check Program].

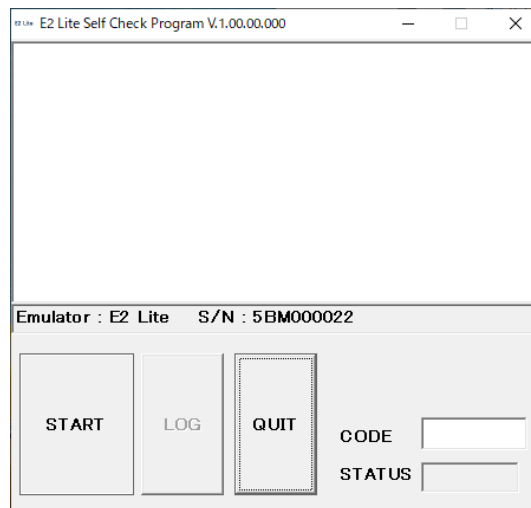

Figure A.1 Starting the E2 Lite SCP

(2) Click on the [START] button to start the SCP.

Do not enter any value in the [CODE] textbox since it is not used at this stage.

If the user-system interface cable is connected to the user system and you click on the [START] button, the following message is displayed:

“Please remove the user interface cable.”

If this message is displayed, disconnect the user-system interface cable from the user system and click on the [OK] button. The SCP then starts.

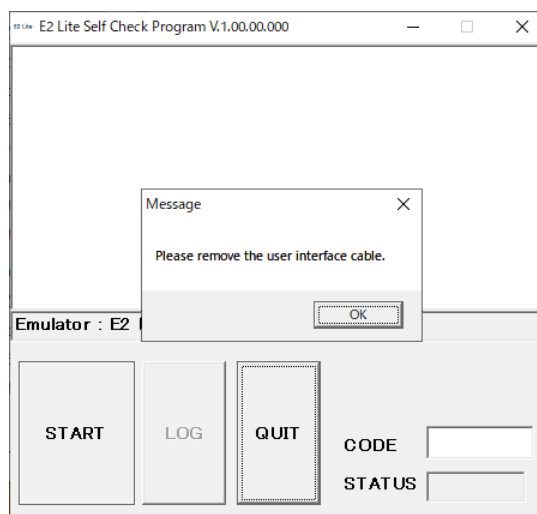

Figure A.2 Checking the Connection of the User-System Interface Cable

If the user-system interface cable is connected to the emulator when you click on the [OK] button, "FAIL" is displayed on the screen (see the figure below). Disconnect the user-system interface cable from the emulator and click on the [START] button again to start the SCP.

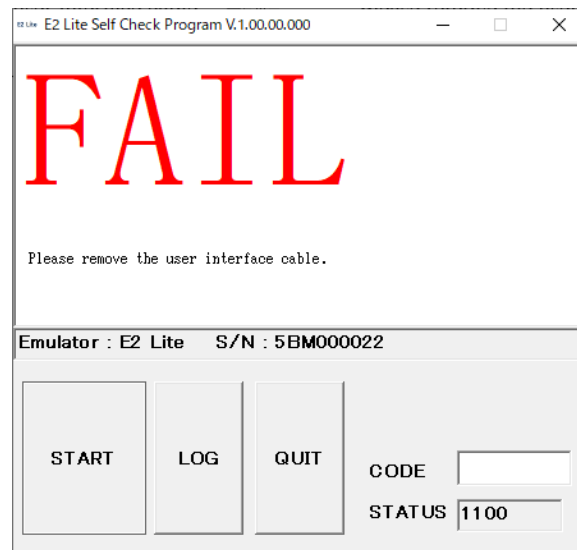

Figure A.3 [FAIL] at the Start of Self-Checking (when the User-System Interface Cable is Connected to the Emulator)

If the USB interface cable is removed from the emulator during the execution of the SCP, "FAIL" is displayed on the screen (see the figure below). Correctly connect the USB interface cable to the emulator and click on the [START] button again to start the SCP.

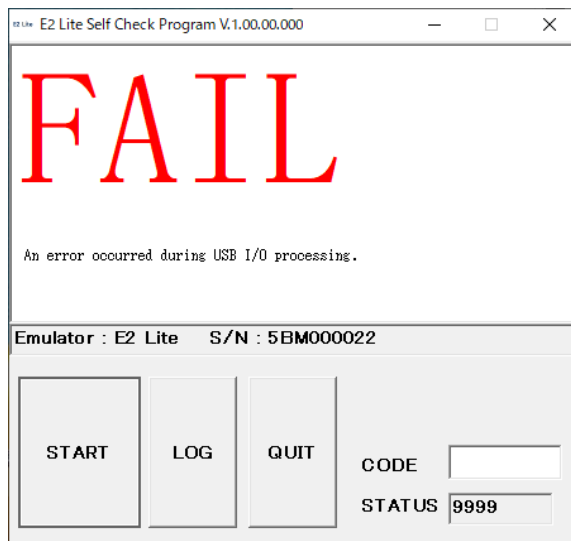

Figure A.4 [FAIL] Display that Appears when an Error Occurs in USB I/O Processing

(3) The SCP is started.

“TEST1 is running.” and “TEST2 is running.” are displayed on the screen.

If the emulator correctly completes TEST1 and TEST2, “TEST1: PASS” and “TEST2: PASS” are displayed on the screen.

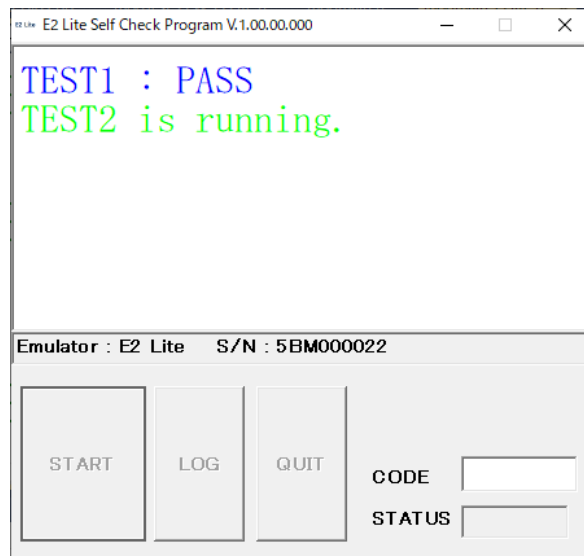

Figure A.5 Starting the SCP

(4) The result is displayed when execution of the SCP is completed.

“PASS” appears on the screen after result of the SCP is correct completion.

“PASS” indicates that the SCP has detected no faults in the E2 Lite.

Click on the [QUIT] button to end the SCP.

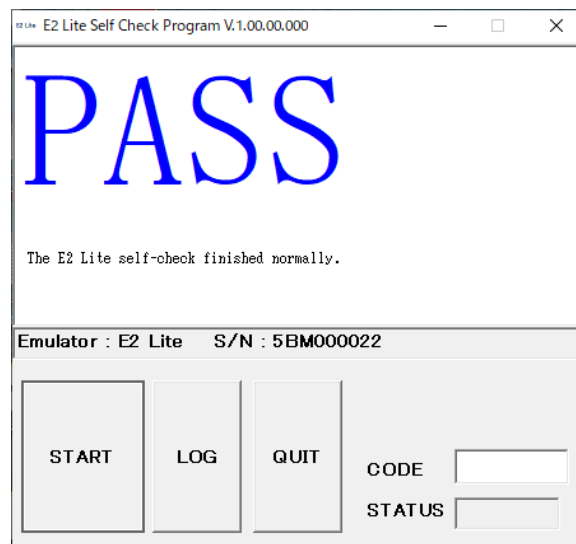

Figure A.6 Correct Completion of the SCP

If correct completion has not been obtained at the end of the SCP, the word “FAIL” is displayed, followed by an error message in the center of the window. Table A.1 lists the error messages.

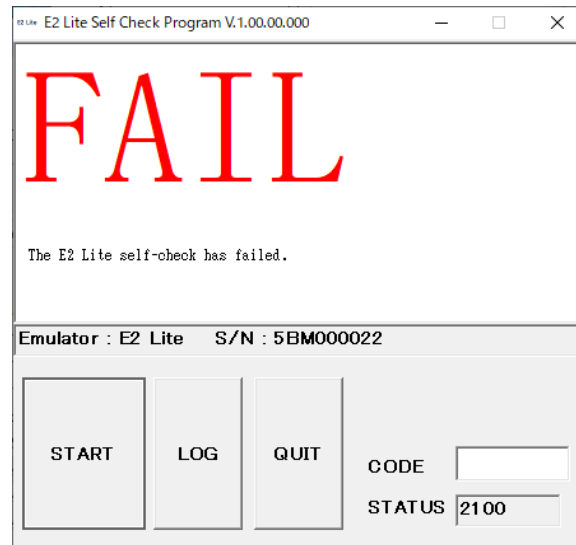

Figure A.7 Display for an Error Found in Self-Checking

Clicking on the [LOG] button opens the file selection dialog box. Specify the location where you want the results of self-checking to be saved. The results of self-checking are saved as a text file.

Table A.1 Error Messages

| Message | Description |
|--|---|
| The E2 Lite self-check has failed. | The user-system interface cable is connected to the user system or the SCP has detected a fault in the E2 Lite after it was started. If the fault falls under the warranty condition stated in section 4, Maintenance and Warranty, we will replace the product for free. In other cases, please purchase a new E2 Lite since we do not offer a repair service for this product. |
| An error occurred during USB I/O processing. | The USB interface cable is removed or the SCP detected a fault in the E2 Lite during execution of the checking. Connect the USB interface cable again and re-start the SCP. If this error message appears again, it indicates the detection of a fault in the E2 Lite. |

| | |
|-------------------------|---|
| Revision History | E2 emulator Lite RTE0T0002LKCE00000R User's Manual |
|-------------------------|---|

| Rev. | Date | Description | |
|------|---------------|-------------|---|
| | | Page | Summary |
| 1.01 | Jun. 1, 2015 | — | First Edition issued. |
| 1.02 | Mar. 15, 2016 | 14 | Regulatory Compliance Notices were changed. |
| 2.00 | Oct. 16, 2019 | 12 | A statement regarding the user-system interface cables (that they are separately available) was added. |
| | | 13 | Table 1.2: Descriptions of the 20-pin (1.27-mm pitch) and 10-pin (1.27-mm pitch) connectors were added. |
| | | 14 | Regulatory Compliance Notices were changed. |
| | | 17 | The description of the user-side connector (20 pins) was changed. |
| | | 21 | Table 2.1: Recommended connectors were added to the list. |
| | | 22 | Figure 2.4, Connecting the User-System Interface Cable to the 20-Pin Connector when the E2 Lite is to be Used, was added. |
| 3.00 | May.15.20 | 30 | Appendix A, E2 Lite Self-Checking Program (SCP), was added. |
| 3.10 | Oct. 16.23 | 26 | 2.6 Hot plug-in, were modified |

E2 emulator Lite RTE0T0002LKCE00000R

User's Manual

Publication Date: Oct.16.23 Rev.3.10

Published by: Renesas Electronics Corporation

E2 emulator Lite
RTE0T0002LKCE00000R
User's Manual

Looking for pricing, stock, or lifecycle information?

Click below to explore more details on WIN SOURCE:

- ⊖ [View RTE0T0002LKCE00000R on WIN SOURCE](#)
- ⊖ [Renesas Electronics America Information](#)

Optimize Your Supply Chain with WIN SOURCE Solutions

- ✓ Global Sourcing Solution
- ✓ Obsolete Management
- ✓ Cost Control Management
- ✓ Shortage Management
- ✓ Alternative Solution
- ✓ Excess Inventory Management