



**THE DATASHEET OF  
BTB24-12W12S**



# The Fifth Generation, Ultra Small Size, Isolated Type DC-DC Converter

## Bellnix® 3Watt BTB Series

BTB series is a thin, high efficiency, low noise isolated type DC-DC converter. To achieve miniaturization a new circuit was adopted. Circuit construction is made simple yet highly efficient. Adjustable output voltage and remote ON/OFF control has been added as a new function.



### <Features>

- Adjustable Output Voltage
- Remote ON/OFF Control
- Dual Power Supply usable as Single Power Supply
- Isolation Voltage AC500V
- Over-Current Protection
- Under Voltage Lock Out
- Built-in Over Input Current Protection Element
- No Electrolytic Capacitor, No Tantalum Capacitor
- MTTF 2,000,000 Hrs
- Metallic Shield Cover
- Halogen-Free PCB Used
- Between Primary and Secondary combination capacitance is approx. 40 to 140pF
- Operating Temp. Range -40°C to +85°C (Temp. Derating required)
- RoHS Compliance
- UL/c-UL Approved

### <Model, Rating>

Table 1

Model	Input V Vdc	Output V Vdc	Output I mA	Line Reg. mV(max.)	Load Reg. mV(max.)	Ripple Noise mVpp(typ.)	Efficiency %(typ.)
BTB05-03S80X	4.5 to 9	3.3	0 to 800	20	40	40	73
BTB05-05S60X		5	0 to 600				77
BTB05-12S25X		12(15)	0 to 250 (200)	40	100	30	82
BTB05-12W12X		±12(±15)	0 to 125 (100)	80	600		80
BTB12-03S80X	9 to 18	3.3	0 to 800	20	40	40	74
BTB12-05S60X		5	0 to 600				79
BTB12-12S25X		12(15)	0 to 250 (200)	40	100	30	82
BTB12-12W12X		±12(±15)	0 to 125 (100)	80	600		81
BTB24-03S80X	18 to 36	3.3	0 to 800	20	40	40	73
BTB24-05S60X		5	0 to 600				78
BTB24-12S25X		12(15)	0 to 250 (200)	40	100	30	82
BTB24-12W12X		±12(±15)	0 to 125 (100)	80	600		81
BTB48-03S80X	36 to 76	3.3	0 to 800	20	40	40	73
BTB48-05S60X		5	0 to 600				79
BTB48-12S25X		12(15)	0 to 250 (200)	40	100	30	81
BTB48-12W12X		±12(±15)	0 to 125 (100)	80	600		80

Note1: The suffix for the model type should be inserted into the X. D:DIP type, S:SMD type

Ex) DIP type: BTB05-03S80D, SMD type: BTB05-03S80S

Note2: The output voltage inside () is when it is shorted between Vadj and -Vout.

Note3: The output current inside () is when it is adjusted to the max. output voltage.

# The Fifth Generation, Ultra Small Size, Isolated Type DC-DC Converter

## **Bellnix®** **3Watt BTB Series**

<Specification>

Table2

Input Voltage Range	Refer to Table 1
Rating Output Voltage	3.3V±3%, 5V±3%, 12V±3%, ±12V±5% (Vadj pin open)
Adjustable Output Voltage Range	3.15 to 3.6V (For 3.3V), 4.75 to 6.0V (For 5V), 11.4 to 15V (For 12V), ±11.4 to ±15V (For ±12V)
Line Regulation	Refer to Table1 (Rating output, for the regulation of input voltage range of table1)
Load Regulation	Refer to table1 (Rating input/output voltage, for the load regulation from 0 to 100% (±Output is when load is at balance))
Temp. Regulation	80mV max. (For 3.3V, 5V), 200mV max. (For 12V), 300mV max. (For ±12V) (Input/output rating, for operating temp. -40°C to +50°C)
Ripple/Noise	Refer to Table 1 (Rating input/output, at room temp, 20MHz bandwidth)
Efficiency	73% to 82% typ. (Rating input/output, at room temp., Refer to table 1)
Over Current Protection Circuit	Operates at 105% or more rating load current, auto recovery type. Avoid usage in over current for more than 30 seconds.
Over Voltage Protection Circuit	None
Low Input Voltage Protection	Available (Refer to p.11)
Over Input Current Protection	Built-in fuse in input (refer to p.12)
Remote ON/OFF	Between 2pin (ON/OFF) and 3pin (-Vin) : Output goes OFF at open, Output goes ON when in short. (Refer to p.9)
Stand by Current	0.8 to 2.4mA typ. (Depend on model)
Isolation Voltage	Input-Output, Input-Case, Output-Case AC500V 1min.
Isolation resistance	Input-Output, Input-Case, Output-Case 50MΩ or more at DC500V.
Primary-Secondary capacitance	Approx. 40 to 140pF (Depend on model)
Operating Temp. Range	Operating Temp. -40°C to +85°C (temp. derating required from +50°C)
Storage Temp. Range	Storage Temp. -40°C to +85°C
Humidity Range	Humidity range 95%R.H. max. (Max. wet bulb temp. 38°C, non-condensing)
Cooling Condition	Air flow cooling (Set in a place where air convection is ensured)
Vibration	10 to 55Hz All amplitude 1.52mmp-p (2 hours in each orthogonal axes), Sweep time 15min.
Shock	Acceleration 100G (3 directions, 3 times each, total of 18 times), Duration time 6ms
Weight	4.5g typ.
Outline	DIP type W=16.6 L=23.2 H=8.4 typ. (mm) (For detail dimensions, refer to the outline on p.7) SMD type W=16.6 L=26.2 H=8.5 typ.(mm) (For detail dimensions, refer to the outline on p.8)

NOTE : Unless condition is specified, above specification is regulated as rating value.

# The Fifth Generation, Ultra Small Size, Isolated Type DC-DC Converter

## **Bellnix®** **3Watt BTB Series**

### 1- Application Range

This datasheet applies to the isolated type DC/DC converter, BTB series.

### 2- Model/Rating

Model	Rating Input Voltage	Rating Output	Package
BTB05-03S80D	DC5V	3.3V, 800mA	DIP
BTB05-03S80S			SMD
BTB05-05S60D		5.0V, 600mA	DIP
BTB05-05S60S			SMD
BTB05-12S25D		12V, 250mA	DIP
BTB05-12S25S			SMD
BTB05-12W12D		±12V, each 125mA	DIP
BTB05-12W12S			SMD
BTB12-03S80D	DC12V	3.3V, 800mA	DIP
BTB12-03S80S			SMD
BTB12-05S60D		5.0V, 600mA	DIP
BTB12-05S60S			SMD
BTB12-12S25D		12V, 250mA	DIP
BTB12-12S25S			SMD
BTB12-12W12D		±12V, each 125mA	DIP
BTB12-12W12S			SMD
BTB24-03S80D	DC24V	3.3V, 800mA	DIP
BTB24-03S80S			SMD
BTB24-05S60D		5.0V, 600mA	DIP
BTB24-05S60S			SMD
BTB24-12S25D		12V, 250mA	DIP
BTB24-12S25S			SMD
BTB24-12W12D		±12V, each 125mA	DIP
BTB24-12W12S			SMD
BTB48-03S80D	DC48V	3.3V, 800mA	DIP
BTB48-03S80S			SMD
BTB48-05S60D		5.0V, 600mA	DIP
BTB48-05S60S			SMD
BTB48-12S25D		12V, 250mA	DIP
BTB48-12S25S			SMD
BTB48-12W12D		±12V, each 125mA	DIP
BTB48-12W12S			SMD

### 3- Environmental Condition

#### 3-1 Temperature Range

Operating Temp.: -40°C to +85°C (Derating required from 50°C)

Storage Temp. : -40°C to +85°C

#### 3-2 Humidity Range

Operating Temp.: 95%R.H. max. (Max. wet-bulb temp. 38°C, non-condensing)

Storage Temp. : 95%R.H. max. (Max. wet-bulb temp. 38°C, non-condensing)

# The Fifth Generation, Ultra Small Size, Isolated Type DC-DC Converter

## **Bellnix®** **3Watt BTB Series**

### 4-Specification

#### 4-1 Input Condition, Output Characteristics

When conditions are not mentioned in this data sheet, input is rated input, output is rated output, and ambient temperature at 25°C±5°C.

Model *1	Input Voltage (V)	Output Voltage (V) *2	Output Current (mA)	Max. Output Voltage Stability.			Output Ripple/Noise *4 (mVp-p)typ./ max.	Efficiency (%)typ. *5
				Input (mV)	Load (mV)	Temp. *3 (mV)		
BTB05-03S80X	4.5 to 9	3.3±3%	0 to 800	20	40	80	40 / 120	73
BTB05-05S60X		5.0±3%	0 to 600	20	40	80	40 / 120	77
BTB05-12S25X		12±3%	0 to 250	40	100	200	30 / 120	82
		15±3%	0 to 200	40	100	200	30 / 120	82
BTB05-12W12X		±12±5%	0 to 125 × 2	80	600	300	30 / 120	80
		±15±5%	0 to 100 × 2	80	600	300	30 / 120	81
BTB12-03S80X	9 to 18	3.3±3%	0 to 800	20	40	80	40 / 120	74
BTB12-05S60X		5.0±3%	0 to 600	20	40	80	40 / 120	79
BTB12-12S25X		12±3%	0 to 250	40	100	200	30 / 120	82
		15±3%	0 to 200	40	100	200	30 / 120	82
BTB12-12W12X		±12±5%	0 to 125 × 2	80	600	300	30 / 120	81
		±15±5%	0 to 100 × 2	80	600	300	30 / 120	81
BTB24-03S80X	18 to 36	3.3±3%	0 to 800	20	40	80	40 / 120	73
BTB24-05S60X		5.0±3%	0 to 600	20	40	80	40 / 120	78
BTB24-12S25X		12±3%	0 to 250	40	100	200	30 / 120	82
		15±3%	0 to 200	40	100	200	30 / 120	82
BTB24-12W12X		±12±5%	0 to 125 × 2	80	600	300	30 / 120	81
		±15±5%	0 to 100 × 2	80	600	300	30 / 120	81
BTB48-03S80X	36 to 76	3.3±3%	0 to 800	20	40	80	40 / 120	73
BTB48-05S60X		5.0±3%	0 to 600	20	40	80	40 / 120	79
BTB48-12S25X		12±3%	0 to 250	40	100	200	30 / 120	81
		15±3%	0 to 200	40	100	200	30 / 120	81
BTB48-12W12X		±12±5%	0 to 125 × 2	80	600	300	30 / 120	80
		±15±5%	0 to 100 × 2	80	600	300	30 / 120	80

\*1 Specify the package in X: D: DIP type(Flow)S: SMD type(Reflow)

\*2 Output Voltage includes line regulation, load regulation (balance load), temp. regulation.

\*3 According to temperature regulation from -40 to 50°C.

\*4 Bandwidth 20MHz

\*5 When Rated Input Voltage, max. Output Current.

\*Note: The specification of dual type: Two outputs are in same current.

# The Fifth Generation, Ultra Small Size, Isolated Type DC-DC Converter

## Bellnix® **3Watt BTB Series**

### 4-2 Capacitance of External Capacitor

This product has a limited capacitance for the output external capacitor. Please refer to the below table.

Model	Output External Capacitor	
	Capacitance	
	+output side	-output side
BTBXX-03SXXX	0 to 220 $\mu$ F <sup>*1</sup>	—
BTBXX-05SXXX	0 to 220 $\mu$ F <sup>*1</sup>	—
BTBXX-12SXXX	0 to 100 $\mu$ F <sup>*1</sup>	—
BTBXX-12WXXX	0 to 47 $\mu$ F <sup>*2</sup>	0 to 47 $\mu$ F <sup>*3</sup>

\*1 Sum of C2 and C3 in standard connecting circuit of section 6-1

\*2 Sum of C2 and C4 in standard connecting circuit of section 6-2

\*3 Sum of C3 and C5 in standard connecting circuit of section 6-2

### 4-3 Temp. Derating

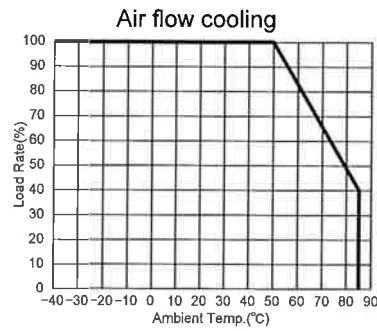

# The Fifth Generation, Ultra Small Size, Isolated Type DC-DC Converter

## Bellnix® **3Watt BTB Series**

### 4-4 Measurement Circuit

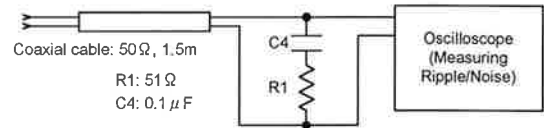
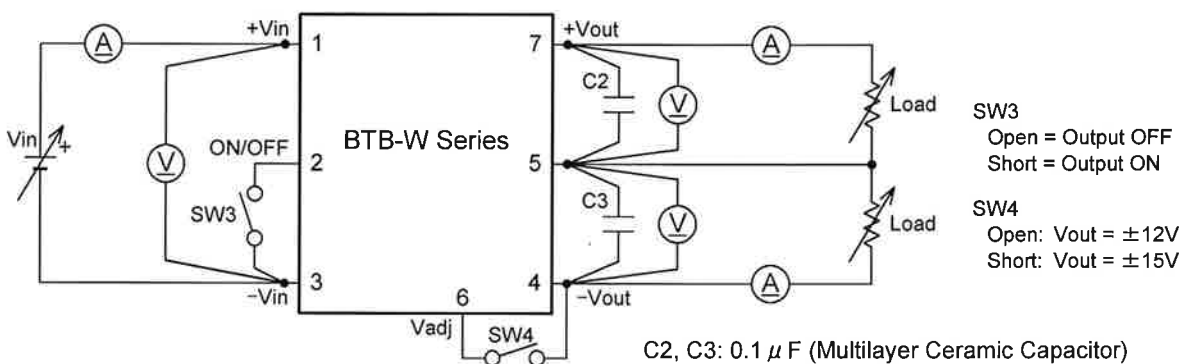
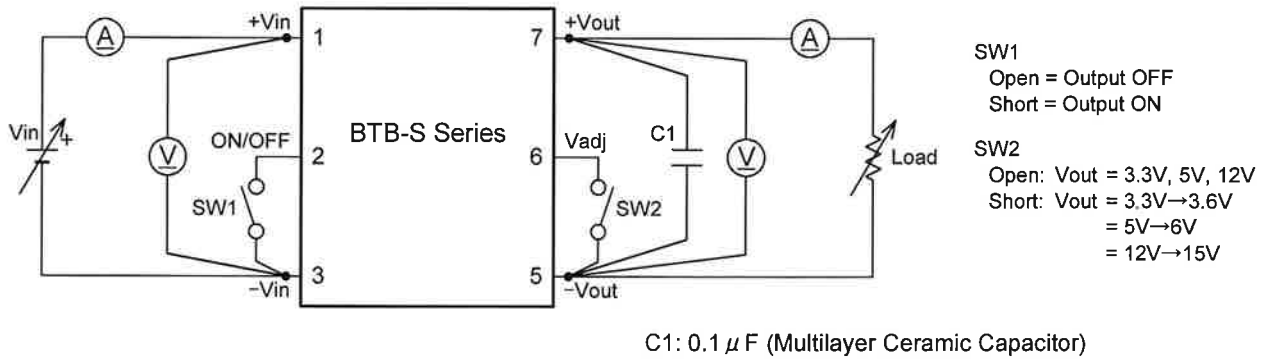

### 4-5 Additional Functions

Article	Specification/Standardization	Condition
Over Current Protection Circuit	Operates above 105%, Auto-recovery type	
Over Voltage Protection Circuit	None	
Low Input Voltage Protection Function	Available	
Output Voltage Adjustable Range	3.15 to 3.6V(BTBXX-03SXXX) 4.75 to 6.0V(BTBXX-05SXXX) 11.4 to 15V(BTBXX-12SXXX) $\pm$ 11.4 to $\pm$ 15V(BTBXX-12WXXX)	With an External Resistor. Refer to 7-2
ON/OFF Control	Output ON at Low(0-0.4V) Output OFF at open	Refer to 7-1

### 4-6 Isolation Voltage, Isolation Resistance

#### 1- Isolation Voltage

Input - Output, Input - Case, Output - Case : AC500V, 1min.

#### 2- Isolation Resistance

Input - Output, Input - Case, Output - Case : 50M $\Omega$  or more (At DC500V)

# The Fifth Generation, Ultra Small Size, Isolated Type DC-DC Converter

## Bellnix® 3Watt BTB Series

5. Outline and Pin  
5-1 DIP type  
1- Outline

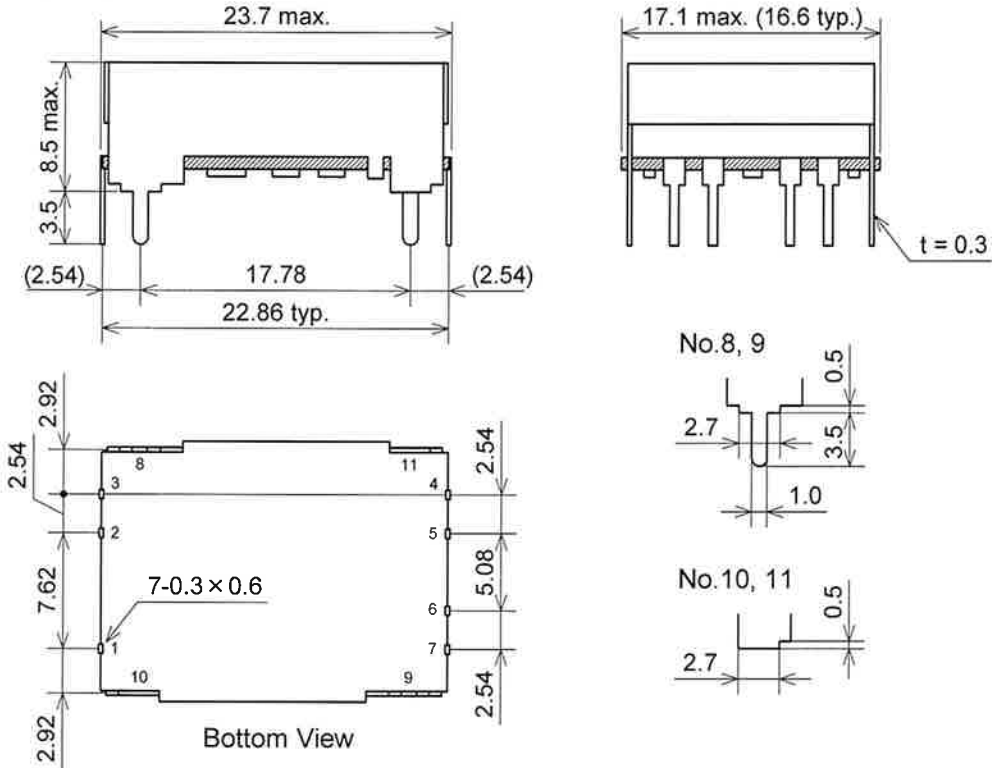

Units : mm  
Tolerance unless otherwise specified : ±0.5

The outline of the pin8 to pin11 is the figure where each pin is viewed from the front side.

Model name and Manufacturing lot No. is indicated on upper side.

2- Recommended dimension of the board, Pin function

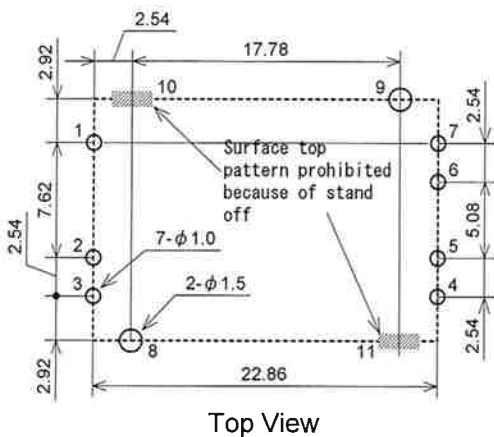

Units : mm

Pin	Function	
	BTB-S	BTB-W
1	+Vin	+Vin
2	ON/OFF	ON/OFF
3	-Vin	-Vin
4	NC	-Vout
5	-Vout	Common
6	Vadj	Vadj
7	+Vout	+Vout
8, 9	Connected to Case	Connected to Case
10, 11	Stand off	Stand off

# The Fifth Generation, Ultra Small Size, Isolated Type DC-DC Converter

## Bellnix® **3Watt BTB Series**

5-2 SMD type

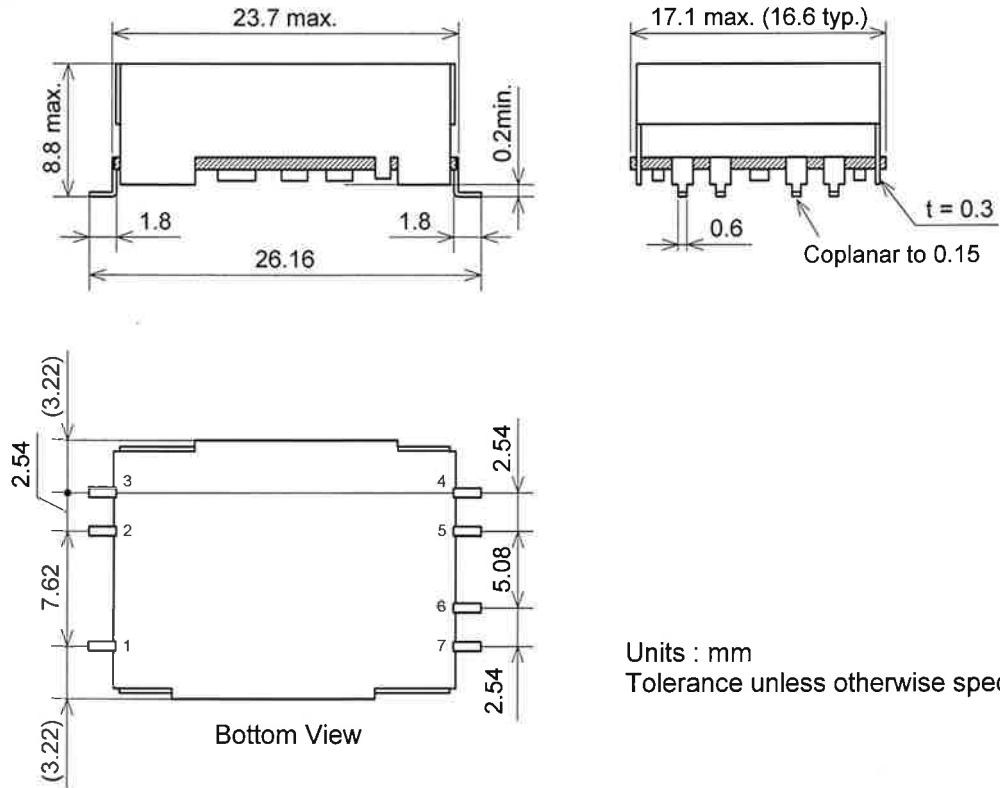

Units : mm  
Tolerance unless otherwise specified :  $\pm 0.5$

### 1-Outline

Model name and Manufacturing LOT no. is indicated on upper side.

### 2- Recommended dimension of the PCB, Pin function

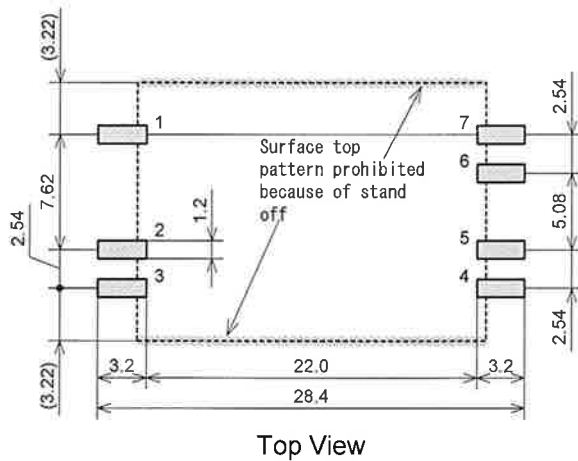

Units : mm

Pin	Function	
	BTB-S	BTB-W
1	+Vin	+Vin
2	ON/OFF	ON/OFF
3	-Vin	-Vin
4	NC	-Vout
5	-Vout	Common
6	Vadj	Vadj
7	+Vout	+Vout

# The Fifth Generation, Ultra Small Size, Isolated Type DC-DC Converter

## Bellnix® **3Watt BTB Series**

### 6. Standard Connection Circuit 1-BTB-S Series

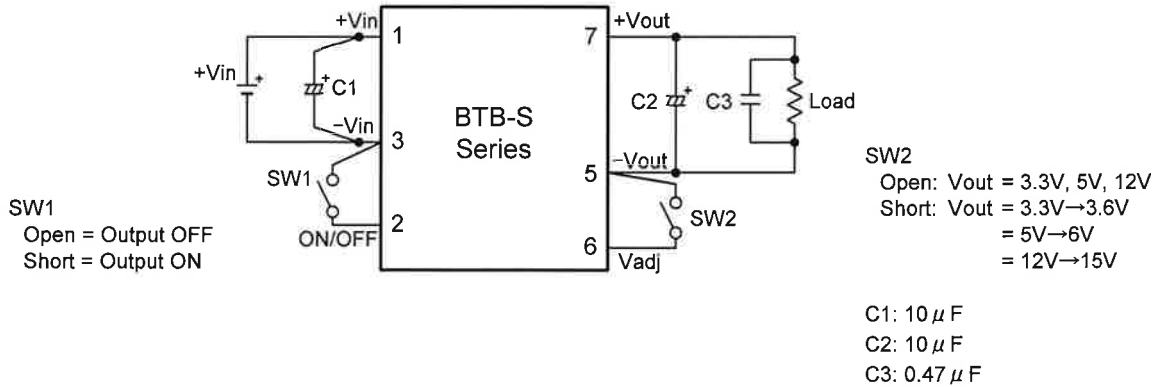

### 2-BTB-W Series

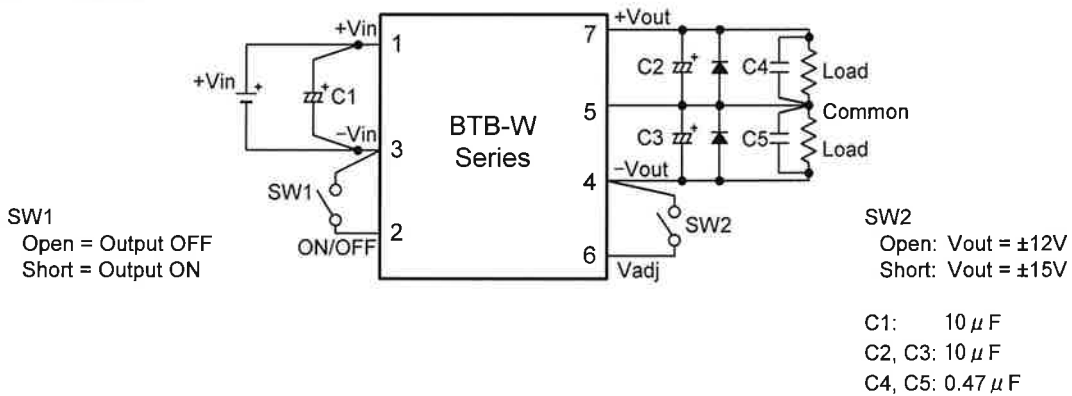

### 7. Functions

#### 7-1 ON/OFF Control

By using the ON/OFF Control, the output voltage can be controlled without charging or discharging the input.

Between  $-V_{in}$  pin (Pin3) and ON/OFF pin (Pin2)

Low (0 to 0.4V 1mA max.) : Output ON  
Open (Max.  $+V_{in}$  voltage will generate) : Output OFF

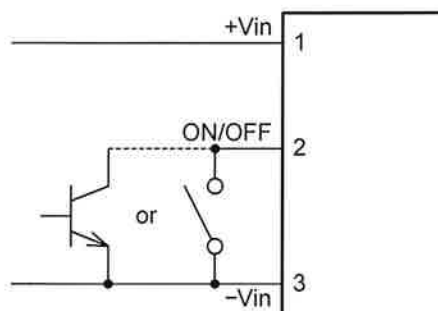

# The Fifth Generation, Ultra Small Size, Isolated Type DC-DC Converter

## Bellnix® **3Watt BTB Series**

### 7-2 To adjust the Output Voltage

Output voltage can be adjusted when Vadj pin and -Vout pin are shorted.  
Please keep this pin open when not adjusting the output voltage.

Output voltage to connection of Vadj pin

Model	Open	-Vout and Short
BTBXX-03SXXX	3.3V	3.6V
BTBXX-05SXXX	5.0V	6.0V
BTBXX-12SXXX	12V	15V
BTBXX-12WXXX	±12V	±15V

Output voltage is adjustable by connecting a resistor between Vadj pin and +Vout pin (or between the Vadj pin and -Vout pin).

Note : When adjusting the output voltage, please operate below max. power

### 7-2-1 To lower the output voltage

Output voltage can be lowered by connecting a resistor Rb between Adjustable Output Pin (Vadj) and Plus Output Pin (+Vout). Calculation is as below. (Unit of Rb is [kΩ]).

BTB-S Series

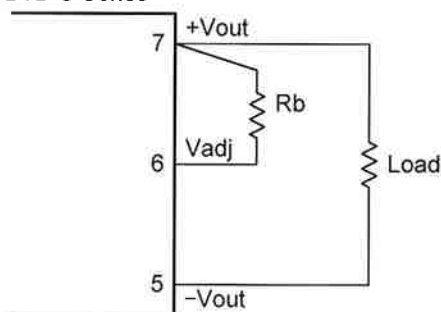

BTB-W Series

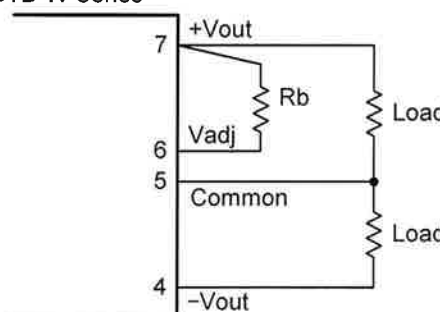

Output Voltage : Vo[V], External resistor : Rb[kΩ]

#### BTBXX-03SXXX

$$V_o = 1.26 \times (91.5 + 2.62 R_b) / (39.6 + R_b)$$

$$R_b = (39.6 V_o - 115.3) / (3.30 - V_o)$$

Adjustable range is may be lowered down to 3.15V. ( $R_b \geq 62$ )

#### BTBXX-05SXXX

$$V_o = 1.26 \times (84.8 + 3.98 R_b) / (31.8 + R_b)$$

$$R_b = (31.8 V_o - 106.85) / (5.01 - V_o)$$

Adjustable range is may be lowered down to 4.75V. ( $R_b \geq 160$ )

#### BTBXX-12SXXX

$$V_o = 1.26 \times (201 + 9.53 R_b) / (57 + R_b)$$

$$R_b = (57 V_o - 253.26) / (12.01 - V_o)$$

Adjustable range is may be lowered down to 11.4V. ( $R_b \geq 620$ )

#### BTBXX-12WXXX

$$V_o = \{1.26 \times (429 + 19.1 R_b) / (103 + R_b)\} / 2$$

$$R_b = (206 V_o - 540.54) / (24.07 - 2 V_o)$$

Adjustable range is up to ±11.4V. ( $R_b \geq 1500$ )

# The Fifth Generation, Ultra Small Size, Isolated Type DC-DC Converter

## Bellnix® **3Watt BTB Series**

### 7-2-2 To raise the output voltage

Output voltage can be raised by connecting a resistor  $R_a$  between the adjustable output pin (Vadj) and minus output pin (-Vout). (Unit for  $R_a$  is[k $\Omega$ ])

BTB-S Series

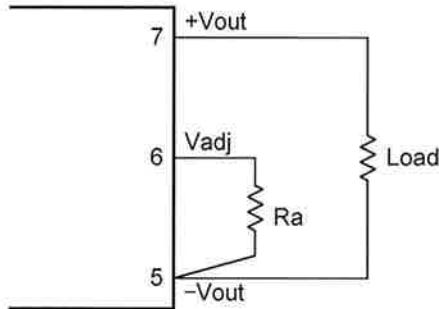

BTB-W Series

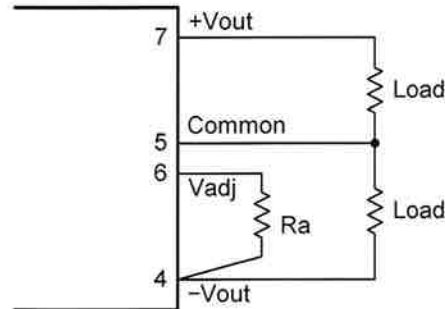

Output Voltage :  $V_o$ [V], External resistor :  $R_a$ [k $\Omega$ ]

#### BTBXX-03SXXX

$$V_o = 1.26 \times (91.5 + 2.62 R_a) / (32 + R_a)$$

$$R_a = (115.3 - 32 V_o) / (V_o - 3.30)$$

#### BTBXX-05SXXX

$$V_o = 1.26 \times (84.8 + 3.98 R_a) / (17.8 + R_a)$$

$$R_a = (106.85 - 17.8 V_o) / (V_o - 5.01)$$

#### BTBXX-12SXXX

$$V_o = 1.26 \times (201 + 9.53 R_a) / (16.9 + R_a)$$

$$R_a = (253.26 - 16.9 V_o) / (V_o - 12.01)$$

#### BTBXX-12WXXX

$$V_o = \{1.26 \times (429 + 19.1 R_a) / (18 + R_a)\} / 2$$

$$R_a = (540.54 - 36 V_o) / (2 V_o - 24.07)$$

### 7-3 Output Over Current Protection Function

Output voltage will be lowered when the output current is in the over current state and the over current protection circuit starts operating. (Over current protection set point : 105 to 250% of rating current value)

It will automatically recover when released from the over current state. In order to avoid damage, please do not keep the over current condition for more than 30sec.

By any reason if the auto recovery does not start after being the over current state released, please turn off the output at the ON/OFF control or switch off to reactivate.

### 7-4 Low Input Voltage Protection Function

This product has a low input voltage protection function installed to avoid malfunction at low input voltages. Commencing operation and termination of voltage range is stated in the table below.

Model	Commencing operation Termination Voltage
BTB05	3.0 to 4.5V
BTB12	6.0 to 9.0V
BTB24	13 to 18V
BTB48	27 to 36V

# The Fifth Generation, Ultra Small Size, Isolated Type DC-DC Converter

## Bellnix® **3Watt BTB Series**

### 7-5 Input Circuit Protection Function

A fuse is built into the input in order to protect the circuit on the secondary side when over current flows to input by some abnormalities.

Rating current and fusing current of the Built-in fuse is shown in the table below. To assure fusing at abnormality, current capacity of power supply should have more than the fusing current, which is stated below.

Model	Rating Current	Fusing Current
BTB05	2.5A	Above 5.0A
BTB12	1.25A	Above 2.5A
BTB24	0.75A	Above 1.5A
BTB48	0.75A	Above 1.5A

### 8. Preventing inverse connection of input power supply (Example)

This product will be damaged when the input polarities are connected reversely. Please connect a protection circuit when connections could be reversed.

The diagram below is an example using a fuse and diode.

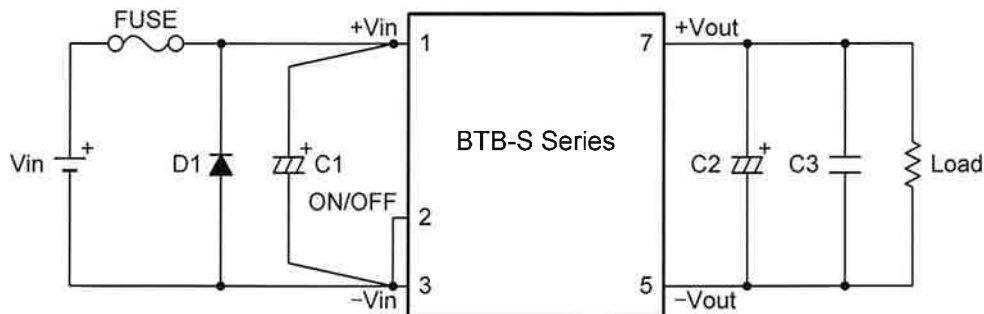

# The Fifth Generation, Ultra Small Size, Isolated Type DC-DC Converter

## **Bellnix®** **3Watt BTB Series**

### 9. Soldering Conditions

Soldering is to be executed under the following conditions.

1- Soldering Iron (DIP Type, SMD Type)  
380°C      less than 3sec.

2- Soldering Dip (DIP type)  
260°C      less than 10sec.

3- Reflow (SMD type)  
Reflow Temp. Profile

Solder Sn-3Ag-0.5Cu

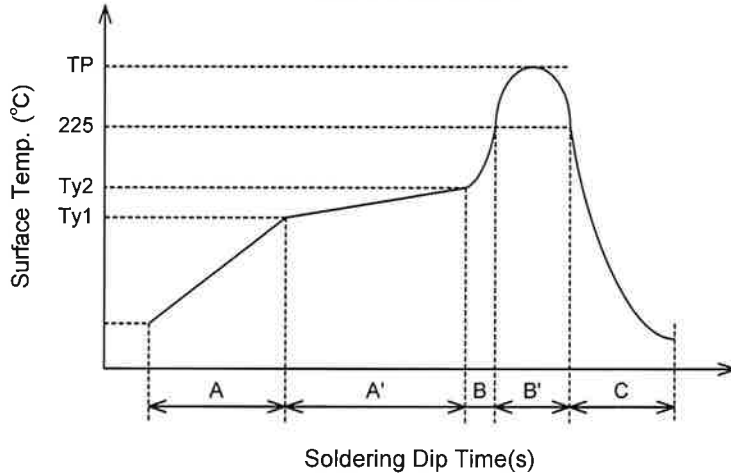

A	1.0 to 3.0°C/s	
A'	Ty1:	150±10°C
	Ty2:	170±10°C
	Ty1 to Ty2:	40 to 100s
B	1.0 to 4.0°C/s	
B'	TP:	245°Cmax.
	Above 225°C:	20 to 40s
C	1.0 to 5.0°C/s	

Do not vibrate the product during reflow.

Reflow can be done only once. (Please do not mount on the backside.)

NOTE: Eutectic soldering can be used if below the conditions stated above.

### 10. Material of Pin and case

Pin : Phosphor bronze (Ni Foundation Sn Plating)

Case : SPCC (Ni Plating)

### 11. Vibration / Shock Test

Vibration : 10 to 55Hz All Amplitude 1.52mmp-p (2 hours each for 3 orthogonal axes)  
Scanning time 15min.

Shock : Acceleration 100G (3 times each for 3 orthogonal axes, Total 18 times )  
Duration 6ms

### 12. Cleaning Condition

This product can not be washed as a whole. The no clean solder paste is recommended for this product. Only when necessary, the Dip type maybe cleaned, using IPA and hand-washed only on the soldered surface by brush cleaning.

After cleaning be sure to dry completely before using.

# The Fifth Generation, Ultra Small Size, Isolated Type DC-DC Converter

## **Bellnix®** **3Watt BTB Series**

---

### 13. Environmental Compliance

This product is RoHS compliance.

Halogen free material is used for PCB.

{Note} RoHS Compliance : Based on EU Directive2002/95/EC.

### 14. Precautions

For the safety of our customer, please follow all warnings and specifications which are stated below.

-This product is intended for use in general electronic appliances (office work machines, telecommunication equipment, and measurement equipments). Do not use for medical equipments, nuclear power equipments, and trains, etc. where the malfunction and damage of this product may directly cause harm to human life and or property. Please confirm when using except in general electronic equipment.

-For this product, parallel operation is not possible.

-For mounting this product, please do not use connectors or sockets. The performance may not be fulfilled by the effect of contacting resistors. Mount onto the PCB by soldering only.

-This product has a built-in over-current, short circuit protection, however long time usage in short circuit should be avoided since this may cause failure to the product.

-This product may be damaged if used under nonstandard electric and environmental conditions such as the temperature. Please be sure to always use within the standard conditions.

-Do not store this product where corrodible gases and dusts may generate.

-Please note that the soldering may degrade if stored in a place with high temperature and humidity or where rapid temperature changes occur for over a year.

-There is a possibility that the product may be damaged from static electricity. The workers should discharge all static electricity before handling the product, and the work atmosphere should also have a static countermeasure.

-This product does not have an over voltage protection.

-No test certificate is attached to this product.



### 15. Guarantee

This product shall be guaranteed for 5 years. During this period, if there should be any failure definitely due to our designing or manufacturing workmanship, we will repair or replace it with a new one at our expense. However, in any case that the product is modified and/or has made any internal remodeling by the buyer, the product can no longer be guaranteed.





This guarantee shall cover only the 3Watt BTB series.

## Looking for pricing, stock, or lifecycle information?

Click below to explore more details on WIN SOURCE:

-  [View BTB24-12W12S on WIN SOURCE](#)
-  [Bellnix Co., Ltd. Information](#)

## Optimize Your Supply Chain with WIN SOURCE Solutions

-  Global Sourcing Solution
-  Obsolete Management
-  Cost Control Management
-  Shortage Management
-  Alternative Solution
-  Excess Inventory Management