



**THE DATASHEET OF
VM800B43A-BK**



FTDI Chip

VM800B Datasheet

Embedded Video Engine

Basic module



General Purpose Multi Media Controller

1 Introduction

The VM800B is a development module for FTDI's FT800, which is used to develop and demonstrate the functionality of the FT800 Embedded Video Engine, EVE.

This module behaves as an SPI slave, and requires a SPI Master for proper micro-controller interfacing and system integration.

VM800B modules support 3 different LCD panel size options and are designed for industrial or commercial environments with precision fitted bezels in either black (-BK) or pearl (-PL).

- VM800B35A-xx is the 3.5" LCD
- VM800B43A-xx is the 4.3" LCD
- VM800B50A-xx is the 5.0" LCD

1.1 Features

The VM800B utilises the FTDI FT800 Embedded Video Engine, EVE. Graphic, audio and touch features of the FT800 chip can be accessed with the VM800B. For a full list of the FT800's features please see the FT800 datasheet. The VM800B has the following features:

- Ready to use LCD module.
- Integrated with resistive touch screen LCD panel
- On board LCD backlight LED Driver
- On board audio power amplifier and micro speaker
- Flexible power supply. Powering the VM800B using either a 2.1mm power jack , SPI master connector or via USB Micro-B port
- 5 V tolerant buffers when used with a 5V SPI Master
- Precision fitted bezel in black(-BK) or pearl (-PL)

2 Ordering Information

Note that the kits below require a 5V/1A power supply. It is NOT provided in the development kit, but is offered as an optional accessory with the following part types:

Part No.	Description
VM800B35A-BK	VM800B module, supports 3.3/5v MCU Adapter Board, 3.5 inch TFT LCD display panel preinstalled, black bezel
VM800B43A-BK	VM800B module, supports 3.3/5v MCU Adapter Board, 4.3 inch TFT LCD display panel preinstalled, black bezel
VM800B50A-BK	VM800B module, supports 3.3/5v MCU Adapter Board, 5.0 inch TFT LCD display panel preinstalled, black bezel
VM800B35A-PL	VM800B module, supports 3.3/5v MCU Adapter Board, 3.5 inch TFT LCD display panel preinstalled, pearl bezel
VM800B43A-PL	VM800B module, supports 3.3/5v MCU Adapter Board, 4.3 inch TFT LCD display panel preinstalled, pearl bezel
VM800B50A-PL	VM800B module, supports 3.3/5v MCU Adapter Board, 5.0 inch TFT LCD display panel preinstalled, pearl bezel
VA-PSU-UK1	Accessory - UK Model 5V/1A USB Power Supply (Mfr # JX-B0520C-1-B)
VA-PSU-US1	Accessory - US Model 5V/1A USB Power Supply (Mfr # JX-B0520B-1-B)
VA-PSU-EU1	Accessory - EU Model 5V/1A USB Power Supply (Mfr # JX-B0520A-1-B)
VA800A-SPI	Accessory - High Speed Micro USB to SPI adapter for BASIC boards based on FT232H MPSSE design
VA-FC-1M-BKW	Accessory - Flat USB A to Micro B Cable 1M- Black and White
VA-FC-1M-BLW	Accessory - Flat USB A to Micro B Cable 1M- Blue and White
VA-FC-STYLUS1	Accessory - Resistive Touch Screen Pen Stylus

Table 2-1 – Ordering information

Note: 3.5" display resolution is 320 x 240 (QVGA).

4.3"/5.0" display resolution is 480 x 272 (WQVGA)

Table of Contents

1	Introduction	1
1.1	Features.....	1
2	Ordering Information	2
3	Hardware Description.....	4
3.1	VM800B module	4
3.2	Physical Descriptions	5
3.2.1	PCB layout.....	5
3.2.2	VM800B Connectors.....	6
4	Board Schematics	9
5	Hardware Setup Guide.....	13
5.1	Power Configuration	13
5.2	MPSSE Setup	13
5.3	Arduino® Setup.....	15
6	Assembling the Bezel and Panel Mounting	16
6.1	3.5" Dimensions.....	17
6.2	4.3" Dimensions.....	18
6.3	5.0" Dimensions.....	19
7	Specifications	20
7.1	Optical Specification	20
8	Contact Information	23
	Appendix A - References	23
	Appendix B - List of Figures and Tables.....	24
	Appendix C – Revision History.....	25

3 Hardware Description

Please refer to section 3.2.2 for connector settings. Some VM800B jumpers must be set to work properly with your system.

3.1 VM800B module



Figure 3-1 – VM800B module profile 3.5" display version



Figure 3-2 - VM800B module profile 4.3" display version



Figure 3-3 - VM800B module profile 5" display version

NOTE: Also available in pearl.

The VM800B module is intended for direct use into existing applications that require a display. This module is suitable for interfacing with an external microcontroller that has a SPI Master channel.

The VM800B module is available in multiple options: 3.5, 4.3 or 5.0 inch display options.

The main functions of the VM800B are as follows:

- Micro USB connector
- SPI connector
- 2-pin connector for power supply
- 3.3V regulator: Takes 5V input and outputs 3.3V for on-board circuits
- LCD touch screen panel
- 5V tolerant buffers between the SPI master interface and the Slave interface of the FT800
 - SPI timing requirements can be found in the FT800 datasheet. The on board level converter buffers introduce additional delay. The actual maximum SPI clock frequency depends on the host system timing and connection cable length to the VM800B PCB.
- 3 stage audio filter and power amplifier
- 8Ω speaker
- Audio line out option
- Precision fitted bezel

3.2 Physical Descriptions

3.2.1 PCB layout

The VM800B module PCB layouts are illustrated in Figure 3-4 and Figure 3-5. Boards are four-layer, approximately 1.6 mm thickness.

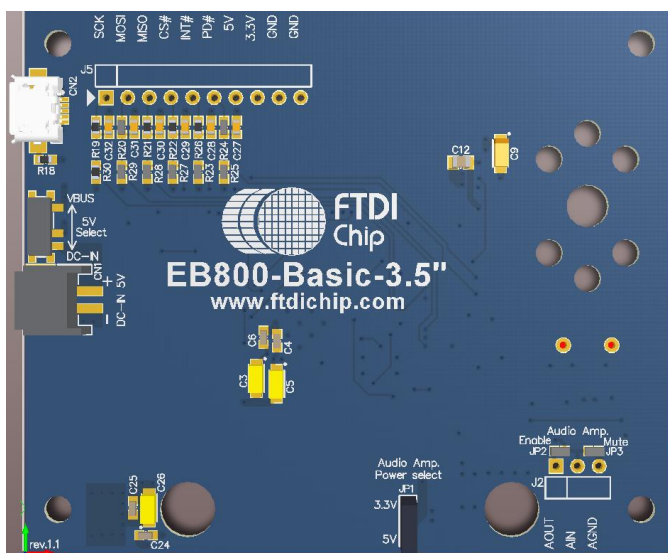

Figure 3-4 - VM800B module PCB view, 3.5 inch display version

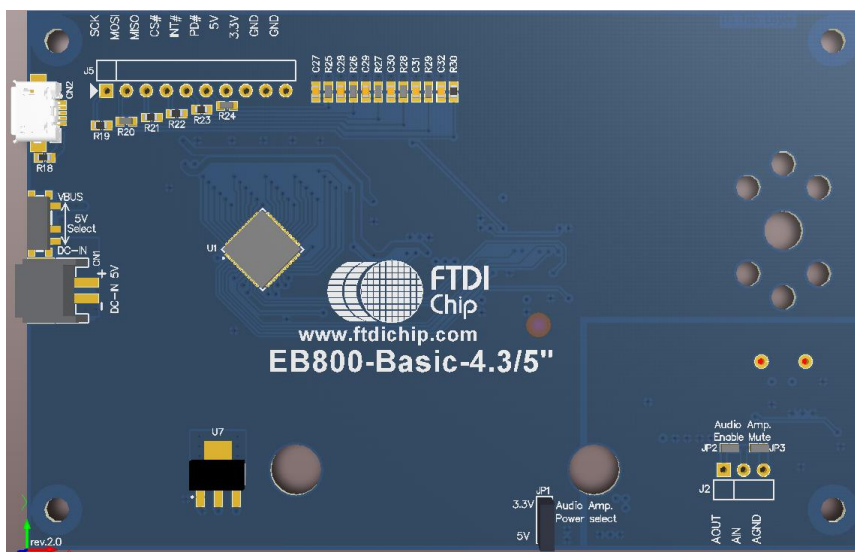

Figure 3-5 - VM800B module PCB view, 4.3 and 5 inch display version

3.2.2 VM800B Connectors

Connectors and jumpers are described in the following sections.

- CN1- 2-pin power connector**

2 pin connector for 5V/3.3V power input to the board. Alternative to Micro USB connector.

Pin No.	Name	Type	Description
1	VCC	P	5V or 3.3V DC power supply
2	GND	P	Ground

Table 3-1 – CN1 Pinout

- CN2- Micro USB Receptacle**

This receptacle is strictly for 5V input to power the board. There is no USB Functionality

Pin No.	Name	Type	Description
1	VBUS	P	5V power supply
2	NC	NA	No connection
3	NC	NA	No connection
4	NC	NA	No connection
5	GND	P	Ground

Table 3-2 – CN2 Pinout

- **J2 - Selection between Lineout and loop back into the power amplifier.**

Selection between audio lineout and loop back into the power amplifier.

Jumper position	Description
Short pin 1-2	Audio amp enabled (default)
Short pin 2-3	Audio amp mute, Audio lineout on pin 1

Table 3-3 – J2 Pin Options

- **J5- SPI Interface**

This is the interface where the SPI control and data signals are routed too. There are also power and ground pins on this interface.

Pin No.	Name	Type	Description
1	SCLK	I	SPI Clock input, 3.3V (5V tolerant)
2	MOSI	I	Master Out Slave in, 3.3V (5V tolerant)
3	MISO	O	Master In Slave out, 3.3V
4	CS#	I	Chip select , active low, 3.3V (5V tolerant)
5	INT#	O	Interrupt output active low, 3.3V
6	PD#	I	Power down control input, active low , 3.3V (5V tolerant)
7	5V	P	5V power supply
8	3.3V	P	3.3V power supply
9	GND	P	Ground
10	GND	P	Ground

Table 3-4 – J5 Pinout

- **JP1- Audio Amplifier Power Select**

This jumper provides the option to select the power supply voltage for the on-board power amplifier.

Jumper position	Description
Short pin 1-2	3.3V selected (default)
Short pin 2-3	5V selected

Table 3-5 – JP1 Pin options

*This needs to be configured before audio can be heard. Default is 3.3V. Select 5V if wants to increase the maximum volume for the speaker.

- **JP2 – On board amplifier enable**

Solder connection not fitted by default.

- **JP3 - On board amplifier mute**

Solder connection not fitted by default.

- **SW1 – Power source select**

Jumper position	Description
Short pin 1-2	Board power from CN1
Short pin 2-3	Board power from CN2 (default)

Table 3-6 – SW1 jumper options

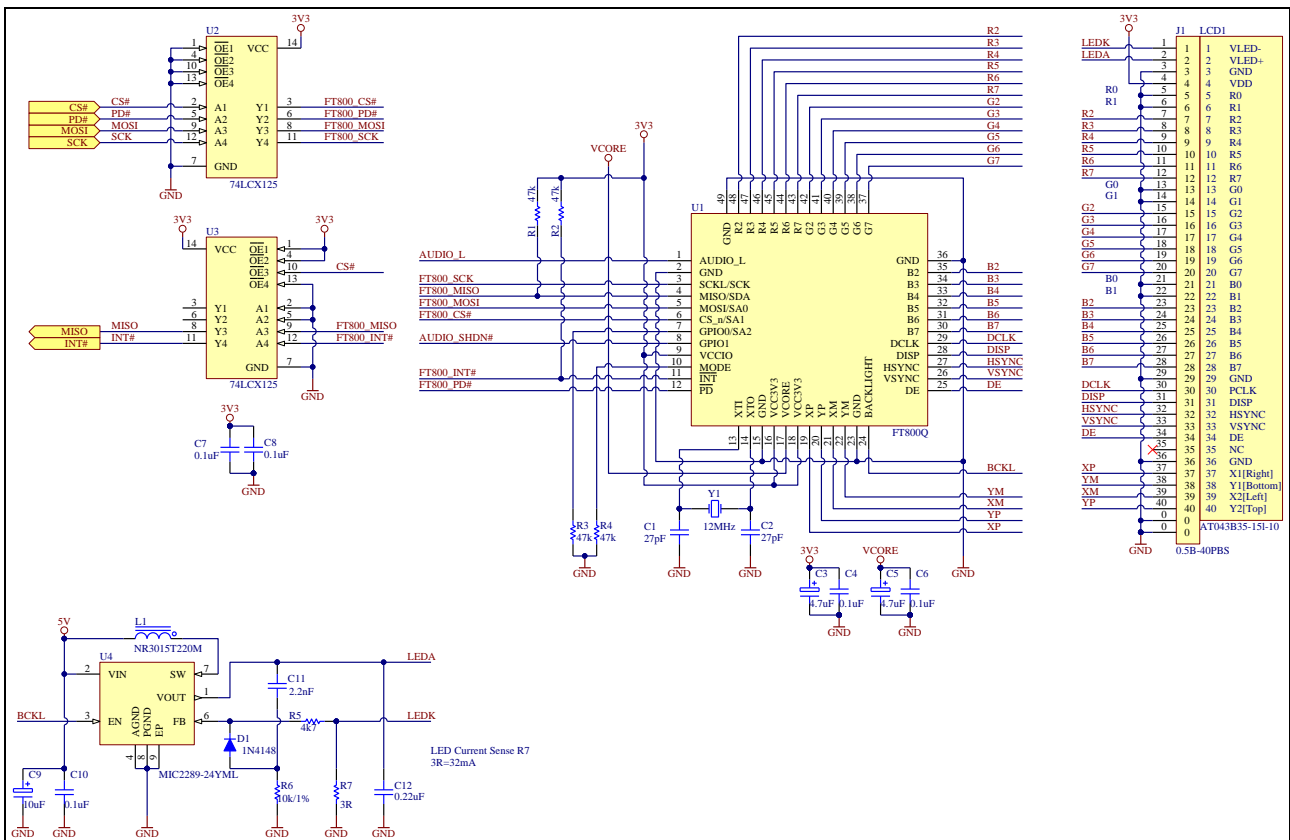

Figure 4-2 - VM800B43A/VM800B50A (4.3"/5.0" Version)

5 Hardware Setup Guide

5.1 Power Configuration

There are 5 methods of powering the VM800B board.

- 1) USB Power(5V) - Connect USB power through micro-USB cable to CN2
- 2) DC IN(5V) - Connect 5V to CN1
- 3) DC IN(3.3V) - Connect 3.3V to CN1 and short J5 pin 7 and 8
- 4) J5 Power(5V) - Connect 5V to J5 pin 7
- 5) *J5 Power(3.3V) - Connect 3.3V to J5 pin 7 and 8

*Warning: Applying 5 V accidentally in this mode may cause permanent damage to the VM800B module.

The following table summarise how to power the VM800B board using the various methods.

Power Method	CN2	CN1	J5 Pin 7	J5 Pin 8	SW1
USB Power	5V	N/C	N/C	N/C	Short pin 2-3
DC IN(5V)	N/C	5V	N/C	N/C	Short pin 1-2
DC IN(3.3V)	N/C	3.3V	SHORT		Short pin 1-2
J5 Power(5V)	N/C	N/C	5V	N/C	Any Position
J5 Power (3.3V)	N/C	N/C	3.3V		Any Position

Table 5-1 Board power configuration

5.2 MPSSE Setup

To provide a quick start with the VM800B development board, Windows based sample projects including source code are provided for users to get a touch and feel experience with the VM800B. An overview of the process is provided in the following paragraphs with more details in [AN_245_VM800CB_SampleAPP_PC_Introduction](#)

MPSSE is a "multi purpose synchronous serial engine" interface available in some FTDI devices (e.g. FT2232D, FT2232H, FT2232H and FT4232H). This engine allows users to bridge from a USB port on a PC to an I²C or SPI interface. Sample code is available for driving the FT800 over this interface with a FT2232H device.

VA800A-SPI is a MPSSE module accessory which can connect to the VM800B modules directly. Detailed information of VA800A-SPI can be found at:

<http://www.ftdichip.com/Products/modules/VA800A-SPI.html>

FTDI also provide a multipurpose MPSSE cable assembly C232HM-EDHSL-0(5V) or C232HM-DDHSL-0(3.3V) for rapid setup. More information on the cable may be found at:

http://www.ftdichip.com/Support/Documents/DataSheets/Cables/DS_C232HM_MPSSE_CABLE.pdf.

In this section it is assumed the VA800A-SPI is used. VA800A-SPI supplies 5 V for VM800B modules. If the VM800B is connected to an SPI interface with a 3.3 V power supply, refer to table 5-1 for the board power configuration. Note, improper power supply and/or IO voltage connection may damage the VM800B module.

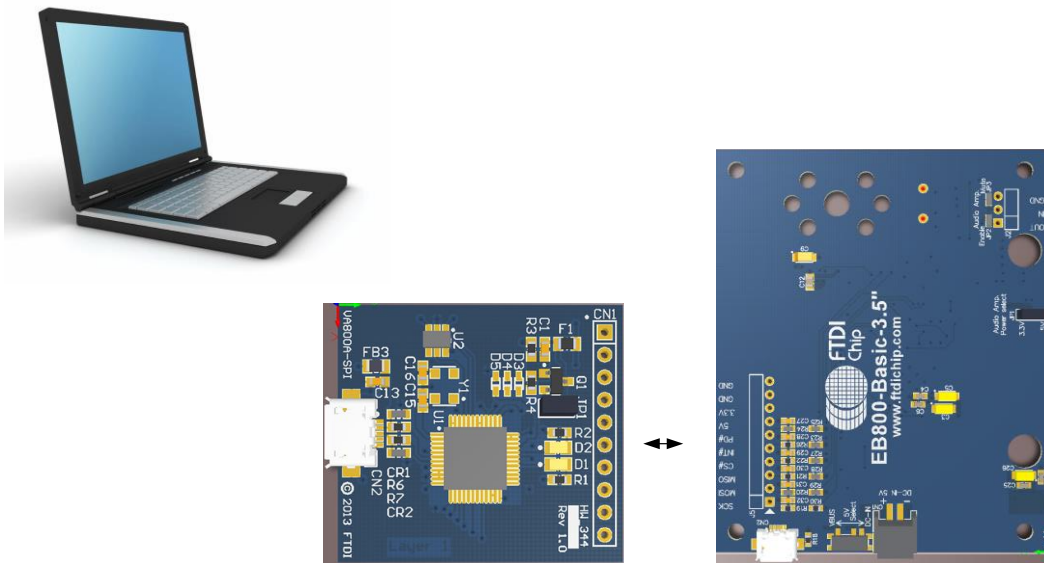

Figure 5-1 – VM800B connects to PC through VA800A-SPI accessory.

Hardware Setup

- Connect the VA800A-SPI to the VM800B module in the correct orientation (with J5-pin1 of VM800B board connected to CN1-pin1 of VA800A-SPI board).
- Connect a USB cable (suggest FTDI accessory **VA-FC-1M-BKW** or **VA-FC-1M-BLW**) from the VA800A-SPI to the PC USB host port or self-powered hub port.
- The VA800A-SPI will supply power to the VM800B after the MPSSE driver is properly loaded and the USB host completes USB device configuration.

NOTE: If using the C232HM-EDHSL-0(5V) MPSSE cable then the connection is as:

J5 Pin number	J5 Signal	MPSSE pin number	MPSSE Signal	MPSSE Cable Lead Colour
1	SCK	2	SK	ORANGE
2	MOSI	3	DO	YELLOW
3	MISO	4	DI	GREEN
4	CS#	5	CS	BROWN
5	INT#	7	GPIOL1	PURPLE
6	PD#	9	GPIOL3	BLUE
7	5V	1	VCC	RED
8	3.3V	-	-	-
9	GND	10	GND	Black
10	GND	-	-	-

Table 5-2 – MPSSE cable (C232HM-EDHSL-0) connection

Software Setup

- The following software setup steps apply to both the VA800A-SPI and MPSSE cable assembly.
- Download the MPSSE software. MPSSE cable and driver information can be found at <http://www.ftdichip.com/Products/Cables/USBMPSSE.htm>.
- Launch the demo application based on MPSSE from the PC

The demo application notes can be found at following link:
[AN_245_VM800CB_SampleAPP_PC_Introduction](#)

5.3 Arduino® Setup

Sample code and demo applications are provided to users who want to connect the VM800B to a MCU. FTDI provides sample source code, sample application notes and a ready to run demo based on the Arduino® platform. Detailed information can be found at:
<http://testwebsite/Products/modules/VM800B.html>

6 Assembling the Bezel and Panel Mounting

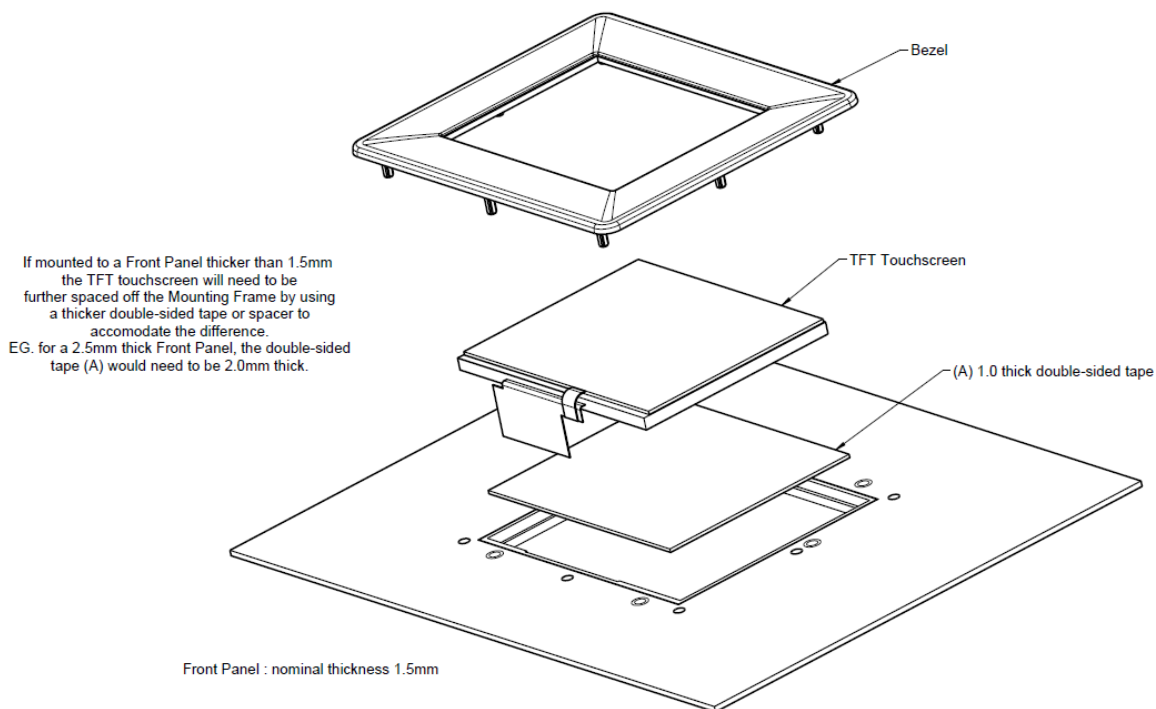

Figure 6-1 - VM800B Panel Mount (Front view)

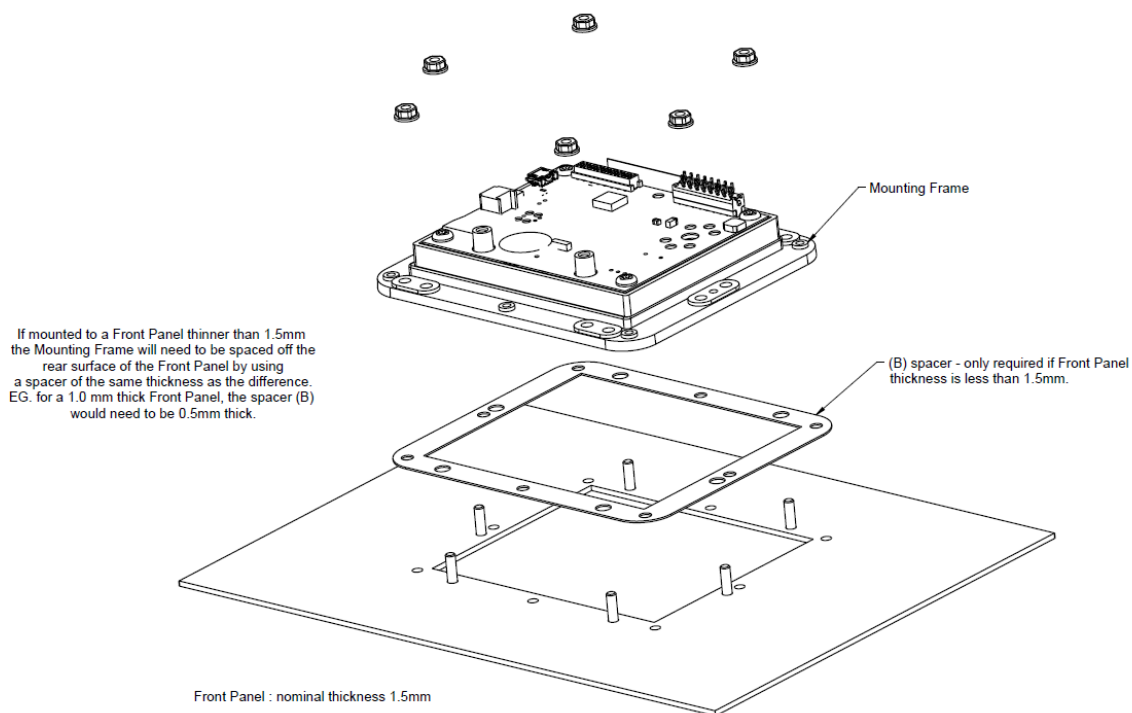

Figure 6-2 - VM800B Panel Mount (Rear view)

6.3 5.0" Dimensions

The TFT Touchscreen Mounting Frame is designed to mount to a 1.5mm thick Front Panel. If mounted to a Front Panel thicker than 1.5mm, longer mounting studs or screws should be used to accommodate the difference.

The Mounting Frame has been designed to work with projection welded studs or csk screws 'A' or press studs 'B'. For a 1.5mm thick Front Panel use -
M3 x 8 long weld studs,
M3 x 10 long countersunk screws or
M3 x 10 long pressed studs

When using countersunk screws to assemble the Mounting Frame, the screws should be located at the 'A' position

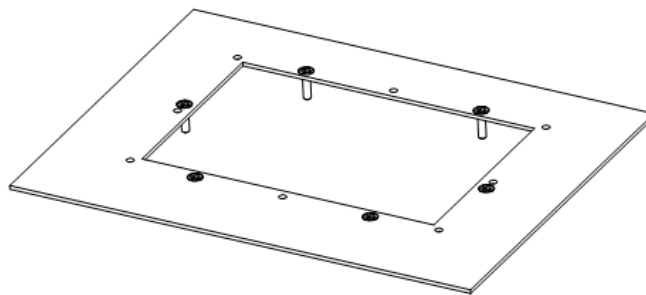
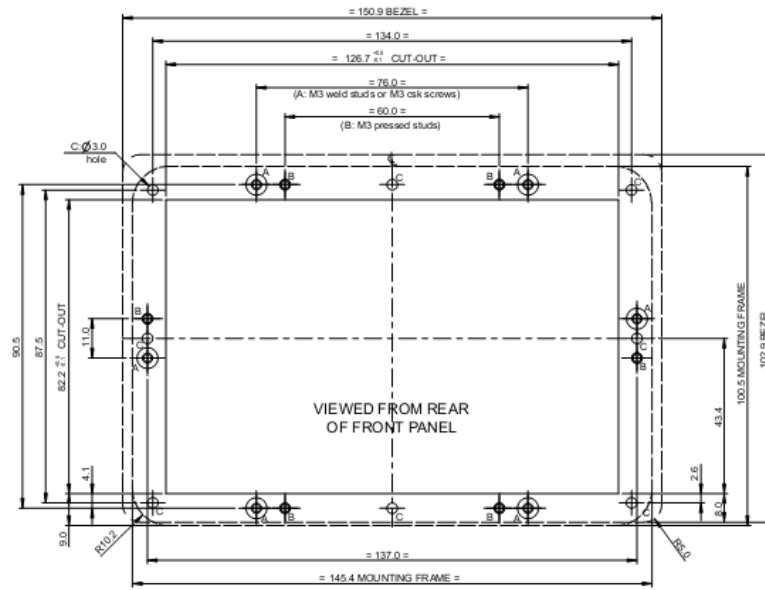

Figure 6-5 - VM800B 5.0" panel mount dimensions

7 Specifications

7.1 Optical Specification

Item	Symbol	Condition	Min	Typ.	Max.	Unit
View Angles	θT	$CR \geq 10$	30	40		Degree
	θB		50	60		
	θL		50	60		
	θR		50	60		
Contrast Ratio	CR	$\theta = 0^\circ$		350		
Response Time	Ton	25°C		25	40	ms
	Toff					
Chromaticity	White	x	0.260	0.310	0.360	
		y	0.283	0.333	0.383	
	RED	x	0.574	0.624	0.674	
		y	0.318	0.368	0.418	
	GREEN	x	0.300	0.350	0.400	
		y	0.500	0.550	0.600	
	BLUE	x	0.093	0.143	0.193	
		y	0.069	0.119	0.169	
Uniformity	U		75	80		%
NTSC				50		%
Luminance	L			500		cd/m ²

Table 7-1 - 3.5" TFT Optical specification

Item	Symbol	Condition	Min.	Typ.	Max.	Unit
Brightness	Bp	$\theta=0^\circ$	-	350	-	Cd/m ²
Uniformity	Δ Bp	$\Phi=0^\circ$	70	80	-	%
Viewing Angle	3:00	Cr \geq 10	-	45	-	Deg
	6:00		-	20	-	
	9:00		-	45	-	
	12:00		-	40	-	
Contrast Ratio	Cr	$\theta=0^\circ$ $\Phi=0^\circ$	350	500	-	-
Response Time	T _r		-	10	-	ms
	T _f		-	10	-	ms
Color of CIE Coordinate	W	x	$\theta=0^\circ$ $\Phi=0^\circ$	0.28	-	-
		y		0.33	-	-
	R	x		0.51	-	-
		y		0.34	-	-
	G	x		0.31	-	-
		y		0.56	-	-
	B	x		0.15	-	-
		y		0.14	-	-
NTSC Ratio	S	50	60	-	%	

Table 7-2 - 4.3" TFT Optical Specification

Item	Symbol	Condition	Min.	Typ.	Max.	Unit
Brightness	Bp	$\theta=0^\circ$	200	250	-	Cd/m ²
Uniformity	ΔBp	$\Phi=0^\circ$	70	80	-	%
Viewing Angle	3:00	$Cr \geq 10$	-	45	-	Deg
	6:00		-	25	-	
	9:00		-	45	-	
	12:00		-	45	-	
Contrast Ratio	Cr	$\theta=0^\circ$	350	500	-	-
Response Time	T_r	$\Phi=0^\circ$	-	10	-	ms
	T_f		-	10	-	ms
Color of CIE Coordinate	W	x		0.28		-
		y		0.33		-
	R	x		0.51		-
		y		0.34		-
	G	x	$\theta=0^\circ$	0.31		-
		y	$\Phi=0^\circ$	0.56		-
	B	x		0.15		-
		y		0.14		-
NTSC Ratio	S		50	60	-	%

Table 7-3 - 5" TFT Optical Specification

8 Contact Information

Head Office – Glasgow, UK

Unit 1, 2 Seaward Place, Centurion Business Park
Glasgow G41 1HH
United Kingdom
Tel: +44 (0) 141 429 2777
Fax: +44 (0) 141 429 2758

E-mail (Sales) sales1@ftdichip.com
E-mail (Support) support1@ftdichip.com
E-mail (General Enquiries) admin1@ftdichip.com

Branch Office – Tigard, Oregon, USA

7130 SW Fir Loop
Tigard, OR 97223
USA
Tel: +1 (503) 547 0988
Fax: +1 (503) 547 0987

E-Mail (Sales) us.sales@ftdichip.com
E-Mail (Support) us.support@ftdichip.com
E-Mail (General Enquiries) us.admin@ftdichip.com

Branch Office – Taipei, Taiwan

2F, No. 516, Sec. 1, NeiHu Road
Taipei 114
Taiwan, R.O.C.
Tel: +886 (0) 2 8797 1330
Fax: +886 (0) 2 8751 9737

E-mail (Sales) tw.sales1@ftdichip.com
E-mail (Support) tw.support1@ftdichip.com
E-mail (General Enquiries) tw.admin1@ftdichip.com

Branch Office – Shanghai, China

Room 1103, No. 666 West Huaihai Road,
Changning District, Shanghai, 200052
China
Tel: +86 (0)21 6235 1596
Fax: +86 (0)21 6235 1595

E-mail (Sales) cn.sales@ftdichip.com
E-mail (Support) cn.support@ftdichip.com
E-mail (General Enquiries) cn.admin@ftdichip.com

Web Site

<http://ftdichip.com>

Distributor and Sales Representatives

Please visit the Sales Network page of the [FTDI Web site](#) for the contact details of our distributor(s) and sales representative(s) in your country.

System and equipment manufacturers and designers are responsible to ensure that their systems, and any Future Technology Devices International Ltd (FTDI) devices incorporated in their systems, meet all applicable safety, regulatory and system-level performance requirements. All application-related information in this document (including application descriptions, suggested FTDI devices and other materials) is provided for reference only. While FTDI has taken care to assure it is accurate, this information is subject to customer confirmation, and FTDI disclaims all liability for system designs and for any applications assistance provided by FTDI. Use of FTDI devices in life support and/or safety applications is entirely at the user's risk, and the user agrees to defend, indemnify and hold harmless FTDI from any and all damages, claims, suits or expense resulting from such use. This document is subject to change without notice. No freedom to use patents or other intellectual property rights is implied by the publication of this document. Neither the whole nor any part of the information contained in, or the product described in this document, may be adapted or reproduced in any material or electronic form without the prior written consent of the copyright holder. Future Technology Devices International Ltd, Unit 1, 2 Seaward Place, Centurion Business Park, Glasgow G41 1HH, United Kingdom. Scotland Registered Company Number: SC136640

Appendix A - References

For module documentations, please refer to URL below:

<http://testwebsite/Products/modules/VM800B.html>

FT800 datasheet: [DS_FT800_Embedded_Video_Engine](#)

FT800 software programming guide: [FT800_Programmer_Guide](#)

FT800 sample application notes:

[AN_245_VM800CB_SampleAPP_PC_Introduction](#)

[AN_246_VM800CB_SampleAPP_Arduino_Introduction](#)

C232HM-EDHSL-0 datasheet:

http://www.ftdichip.com/Support/Documents/DataSheets/Cables/DS_C232HM_MPSSE_CABLE.pdf

D2xx Programmers Guide:

[http://www.ftdichip.com/Support/Documents/ProgramGuides/D2XX_Programmer's_Guide\(FT_000071\).pdf](http://www.ftdichip.com/Support/Documents/ProgramGuides/D2XX_Programmer's_Guide(FT_000071).pdf)

AN_108: Command Processor for MPSSE and MCU Host Bus Emulation Modes

http://www.ftdichip.com/Support/Documents/AppNotes/AN_108_Command_Processor_for_MPSSE_and_MCU_Host_Bus_Emulation_Modes.pdf

Appendix B - List of Figures and Tables

List of Figures

Figure 3-1 – VM800B module profile 3.5” display version	4
Figure 3-2 - VM800B module profile 4.3” display version	4
Figure 3-2 - VM800B module profile 5” display version	4
Figure 3-3 - VM800B module PCB view, 3.5 inch display version	5
Figure 3-4 - VM800B module PCB view, 4.3 and 5 inch display version.....	6
Figure 4-1 - VM800B35A (3.5” Version)	9
Figure 4-2 - VM800B43A/VM800B50A (4.3”/5.0” Version).....	10
Figure 4-3 – VM800B SPI Interface and IO	11
Figure 4-4 – VM800B Audio	12
Figure 5-1 – VM800B connects to PC through VA800A-SPI accessory.....	14
Figure 6-2 - VM800B Panel Mount (Rear view)	16
Figure 6-3 - VM800B 3.5” panel mount dimensions	17
Figure 6-4 - VM800B 4.3” panel mount dimensions	18
Figure 6-5 - VM800B 5.0” panel mount dimensions	19

List of Tables

Table 2-1 – Ordering information	2
Table 3-1 – CN1 Pinout.....	6
Table 3-2 – CN2 Pinout.....	6
Table 3-4 – J2 Pin Options	7
Table 3-5 – J5 Pinout	7
Table 3-6 – JP1 Pin options	7
Table 3-7 – SW1 jumper options	8
Table 5-1 Board power configuration	13
Table 5-2 – MPSSE cable (C232HM-EDHSL-0) connection.....	14
Table 7-1 - 3.5” TFT Optical specification	20
Table 7-2 - 4.3” TFT Optical Specification.....	21
Table 7-3 - 5” TFT Optical Specification.....	22



Appendix C – Revision History

Document Title: DS_VM800B
Document Reference No.: FT_000881
Clearance No.: FTDI# 348
Product Page: <http://www.ftdichip.com/eve.htm>
Document Feedback: [Send Feedback](#)

Version 1.0	Initial Datasheet released	28/08/13
Version 1.1	Corrected dimensions for 4.3" mpounting in section 6.2	25/03/14
Version 1.2	Updated the optical characteristics for the 4.3" and 5" displays	12/06/14

Looking for pricing, stock, or lifecycle information?

Click below to explore more details on WIN SOURCE:

-  [View VM800B43A-BK on WIN SOURCE](#)
-  [Bridgetek Pte Ltd. Information](#)

Optimize Your Supply Chain with WIN SOURCE Solutions

-  Global Sourcing Solution
-  Obsolete Management
-  Cost Control Management
-  Shortage Management
-  Alternative Solution
-  Excess Inventory Management