

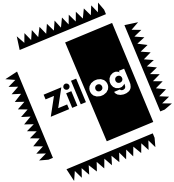

**THE DATASHEET OF
Z16C3220VSG1660**





Z16C32

IUSC™ INTEGRATED UNIVERSAL SERIAL CONTROLLER

FEATURES

- Two Full-Capacity 20 MHz DMA Channels, Each with 32-Bit Addressing and 16-Bit Data Transfers.
- DMA Modes Include Single Buffer, Pipelined, Array-Chained and Linked-Array Chained.
- Ring Buffer Feature Supports Circular Queue of Buffers in Memory.
- Linked Frame Status Transfer Feature Writes Status Information for Received Frames and Reads Control Information for Transmit Frames to the DMA Channel's Array or Linked List to Significantly Simplify Processing Frame Status and Control Information.
- Programmable Throttling of DMA Bus Occupancy in Burst Mode with Bus Occupancy Time Limitation.
- 0 to 20 Mbit/sec, Full-Duplex Channel, with Two Baud Rate Generators and a Digital Phase-Locked Loop for Clock Recovery.
- 32-Byte Data FIFOs for Receiver and Transmitter
- Up to 12.5 MByte/sec (16-Bit) Data Bus Bandwidth
- Multiprotocol Operation Under Program Control with Independent Mode Selection for Receiver and Transmitter.
- Async Mode with One-to-Eight Bits/Character, 1/16 to Two Stop Bits/Character in 1/16 Bit Increments; 16x, 32x, or 64x Oversampling; Break Detect and Generation; Odd, Even, Mark, Space or No Parity and Framing Error Detection. Supports 9-Bit and MIL-STD-1553B Protocols.
- HDLC/SDLC Mode with 8-Bit Address Compare; Extended Address Field Option; 16- or 32-Bit CRC; Programmable Idle Line Condition; Optional Preamble Transmission and Loop Mode. Selectable Number of Flags Between Back-to-Back Frames.
- Byte Oriented Synchronous Mode with One-to-Eight Bits/Character; Programmable Sync and Idle Line Conditions; Optional Receive Sync Stripping; Optional Preamble Transmission; 16- or 32-Bit CRC; Transmit-to-Receive Slaving (for X.21).
- External Character Sync Mode for Receive
- Transparent Bisync Mode with EBCDIC or ASCII Character Code; Automatic CRC Handling; Programmable Idle Line Condition; Optional Preamble Transmission; Automatic Recognition of DLE, SYN, SOH, ITX, ETX, ETB, EOT, ENQ and ITB.
- Flexible Bus Interface for Direct Connection to Most Microprocessors; User Programmable for 8 or 16 Bits Wide. Directly Supports 680X0 Family or 8X86 Family Bus Interfaces.
- Receive and Transmit Time Slot Assigners for ISDN, T1 and E1 (CEPT) Applications.
- 8-Bit General-Purpose Port with Transition Detection
- Low Power CMOS
- 68-Pin PLCC Package
- Electronic Programmer's Manual Support Tool and Software Drivers are Available.

GENERAL DESCRIPTION

The Z16C32 IUSC™ (Integrated Universal Serial Controller) is a multiprotocol datacommunications device with on-chip dual-channel DMA. The integration of a high-speed

serial communications channel with high-performance DMA facilitates higher data throughput than can be achieved with discrete serial/DMA chip combinations.

GENERAL DESCRIPTION (Continued)

There are additional reasons for using the Z16C32 IUSC than just reduced chip count and board space economy. The DMA and serial channel intercommunication offers application benefits as well. For example, events such as the reception of the end of a HDLC frame is internally communicated from the serial controller to the DMA so that each frame can be written into a separate memory buffer. The buffer chaining capabilities, ring buffer support, automated frame status/control blocks, and buffer termination at the end of the frame combine to significantly reduce CPU overhead (Figure 1).

The IUSC is software configurable to satisfy a wide variety of serial communication applications. The 20 Mbit/second data rate and multiple protocol support make it ideal for applications in today's dynamic environment of changing specifications and increasing speed. The many programmable features allow the user to tune the device response to meet system requirements and adapt to future requirements. The IUSC contains a variety of sophisticated internal functions including two baud rate generators, a digital phase-locked loop, character counters, and 32-byte FIFOs for both the receiver and the transmitter.

The on-chip DMA channels allow high speed data transfers for both the receiver and the transmitter. The IUSC supports automatic status and control transfer through DMA and allows initialization of the serial controller under DMA control. Each DMA channel can do a 16-bit transfer in as little as three 50 ns clock cycles and can generate addresses compatible with 32-, 24- or 16-bit memory ranges. The DMA channels operate in any of four modes: single buffer, pipelined, array-chained, or linked-list. The array-chained and linked-list modes provide scatter-read and gather-write capabilities with minimal software intervention. To prevent the DMA from holding bus mastership too long, mastership time may be limited by counting the absolute number of clock cycles, the number of bus transactions, or both.

The CPU bus interface is designed for use with any conventional multiplexed or non-multiplexed bus from manufacturers of CISC and RISC processors including Intel, Motorola, and Zilog. The bus interface is configurable for 16-bit data, 8-bit data with separate address or 8-bit

data without separate address to support multiplexed or non-multiplexed busses.

The IUSC handles asynchronous formats, synchronous bit-oriented formats such as HDLC and synchronous byte-oriented formats (e.g., BISYNC and DDCMP). This device supports virtually any serial data transfer application.

The IUSC can generate and check CRC in any synchronous mode. Complete access to the CRC value allows system software to resend or manipulate the CRC as needed in various applications. The IUSC also provides facilities for modem control signals. In applications where these controls are not needed, the modem controls can be used for general-purpose I/O.

Interrupts are supported by a daisy-chain hierarchy within the serial channel and between the serial channel and the DMA. Separate interrupt vectors for each type of interrupt within the serial controller and the DMA facilitate fast discrimination of the interrupt source. The IUSC supports Pulsed, Double Pulsed, and Status Interrupt Acknowledge cycles.

Support tools are available to aid the designer in efficiently programming the IUSC. The Technical Manual describes in detail all the features and gives programming sequence hints. The Electronic Programmer's Manual, DC #8287-02, is an MS-DOS, disk-based programming initialization tool that can generate custom sequences. Also, Zilog offers assorted application notes and development boards to assist the designer in hardware and software development. Contact your nearest Zilog representative for additional information.

Notes:

All Signals with a preceding front slash, "/", are active Low, e.g.: B//W (WORD is active Low); /B/W (BYTE is active Low, only).

Power connections follow conventional descriptions below:

Connection	Circuit	Device
Power Ground	V_{CC} GND	V_{DD} V_{SS}

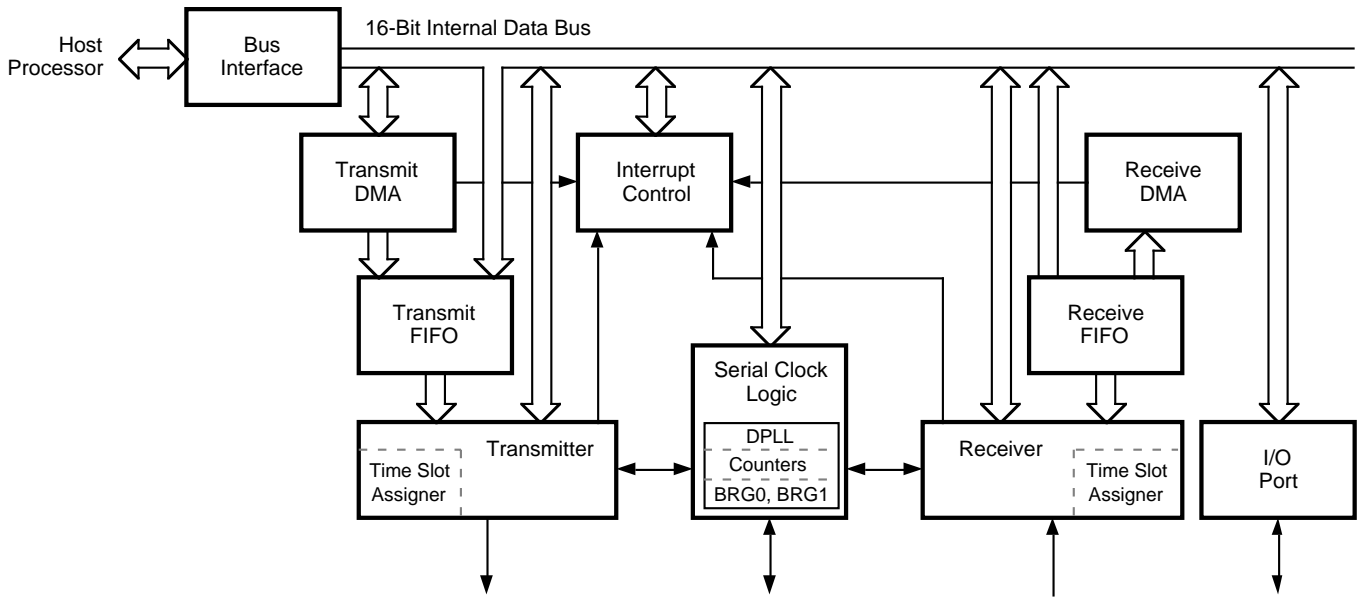

Figure 1. Z16C32 IUSC Block Diagram

GENERAL DESCRIPTION (Continued)

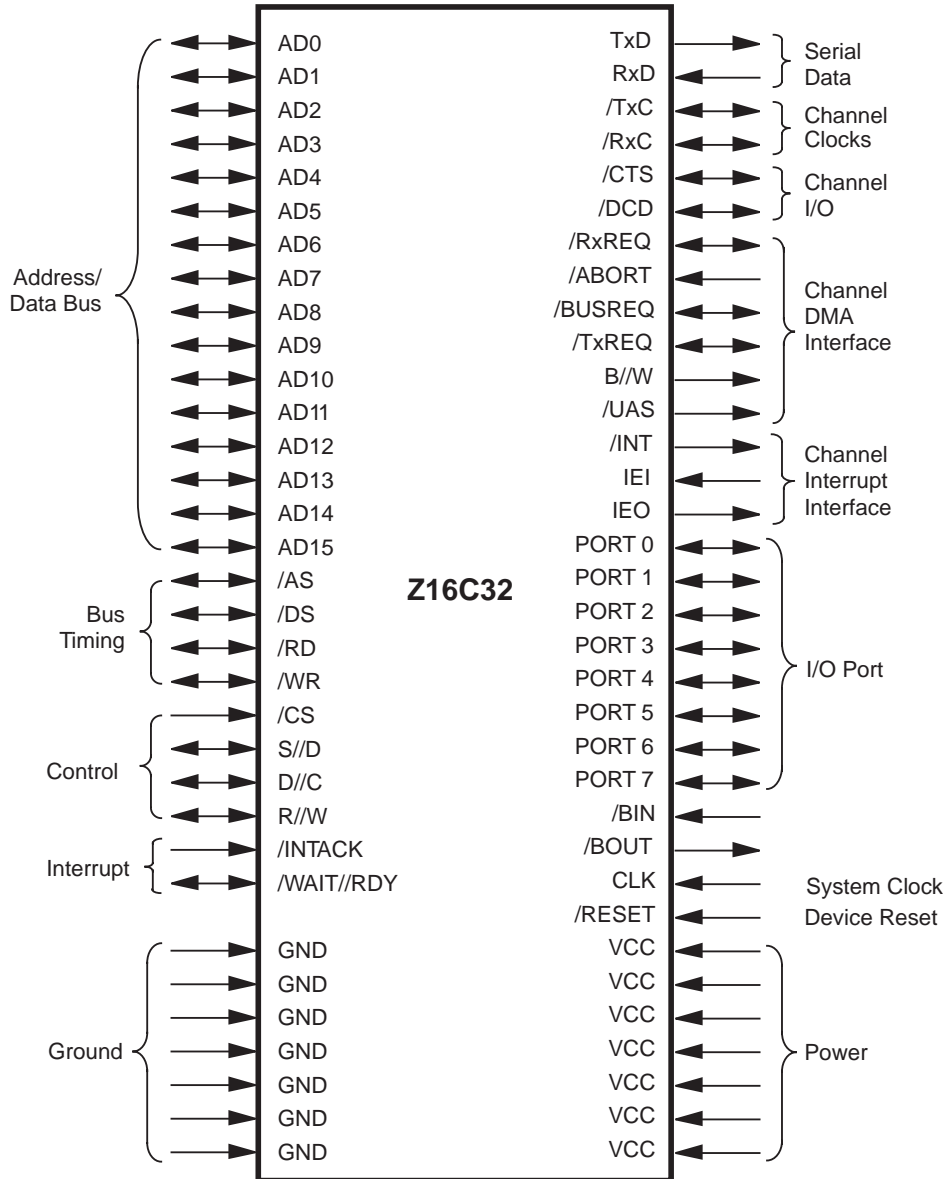

Figure 2. Z16C32 Pin Functions

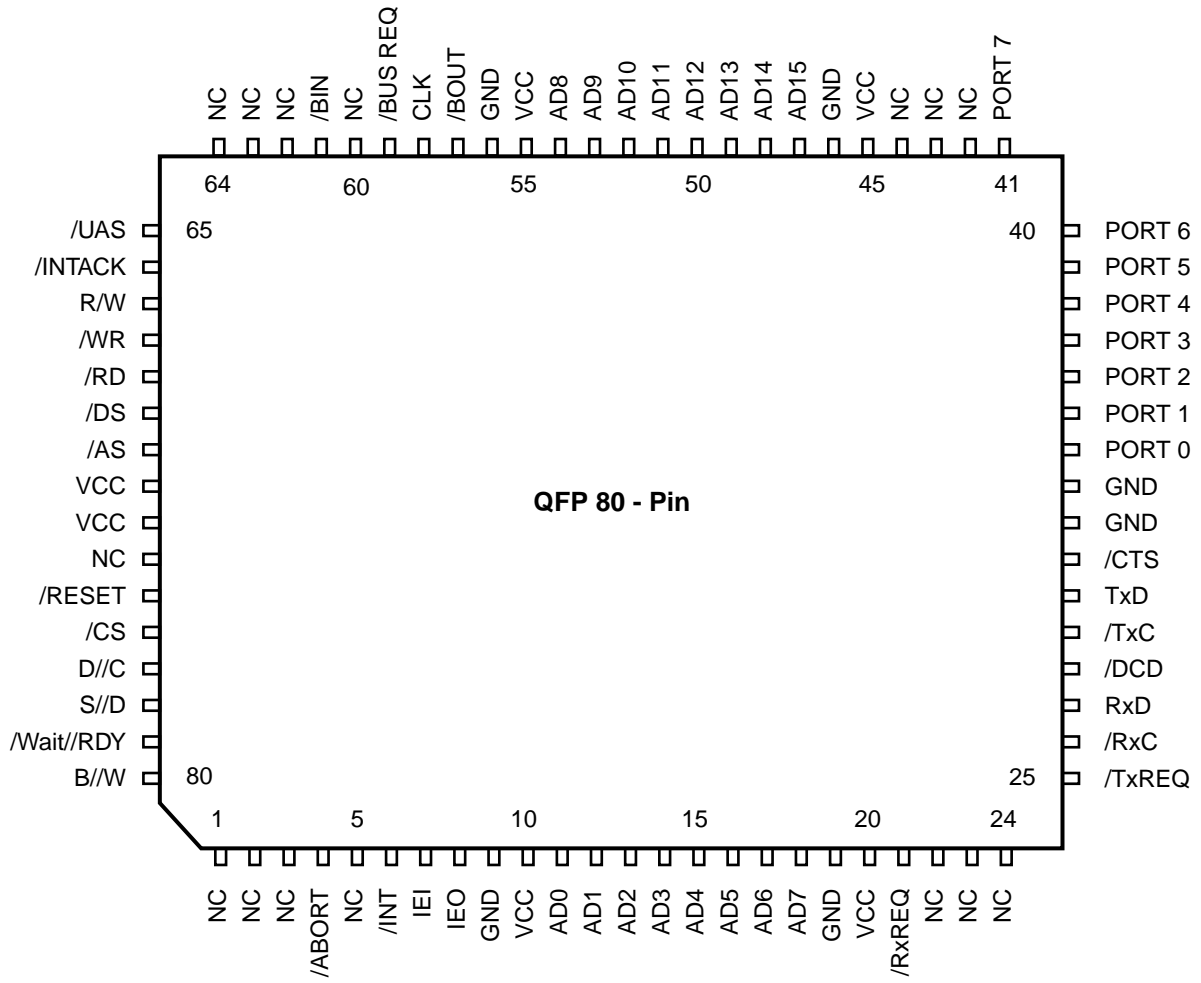

Figure 3. QFP 80-Pin Assignments

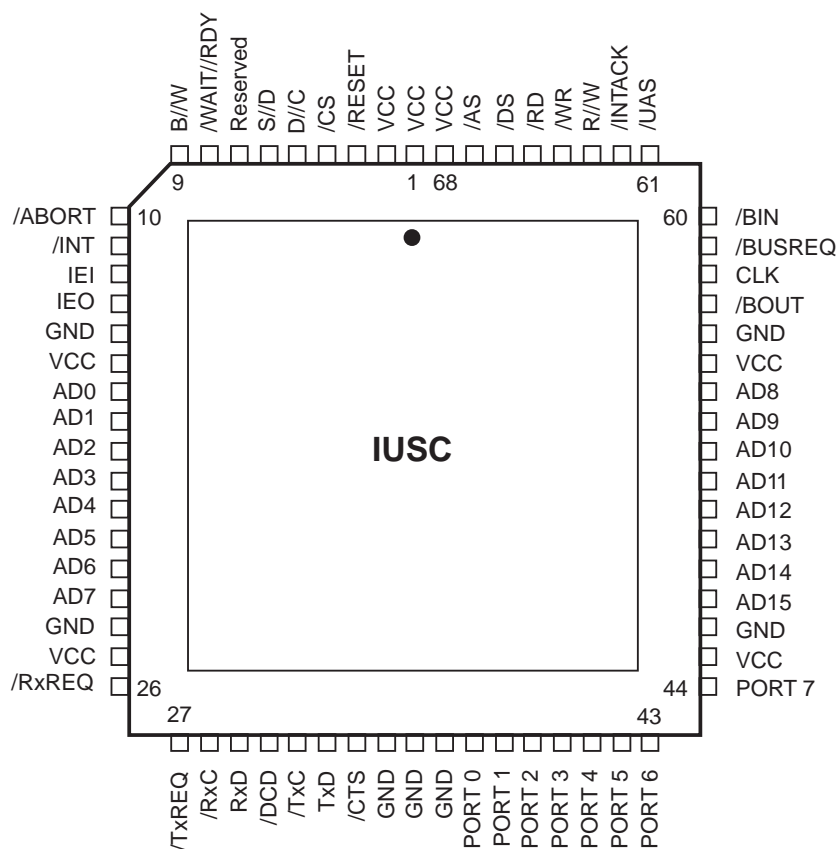

Figure 4. Z16C32 68-Pin PLCC Pin Assignments

PIN DESCRIPTION

Figure 2 shows the logical pin groupings of the IUSC's pins, and Figure 3-4 shows the physical pin assignments.

Only one strobe pin (*/DS*, */RD*, */WR* or Pulsed *INTACK*) should ever be active at one time. Any unused input pin (if an input when the IUSC is bus master or slave) must be pulled up to its inactive state.

/RESET *Reset* (input, active Low). A Low on this line places the IUSC in a known, inactive state, and conditions it so that the data, from the next write operation that asserts the */CS* pin, goes into the Bus Configuration Register (BCR) regardless of register addressing. */RESET* should be driven Low as soon as possible during power-up, and as needed when restarting the overall system or the communications subsystem.

CLK *System Clock* (input). This signal is the timing reference for the DMA and bus interface logic. (The serial controller section is clocked by the selected sources of receive and transmit clocking.)

AD15-0 *Address/Data Bus* (inputs/tri-state outputs). After Reset, these lines carry data between the controlling microprocessor and the IUSC, and may also carry multiplexed addresses of registers within the IUSC. Such operation, between the host processor and the IUSC, is often called slave mode. Once the software has set up the device and placed it into operation, these lines also carry multiplexed addresses and data between the IUSC and system memory; such operation is called master mode. *AD15-0* can be used in a variety of ways based on whether the IUSC senses activity on */AS* after Reset, and on the data written to the Bus Configuration Register (BCR).

/CS *Chip Select* (input, active Low). A Low on this line indicates that the controlling microprocessor's current bus cycle refers to a register in the IUSC. The IUSC ignores */CS* when a Low on */INTACK* indicates that the current bus operation is an interrupt acknowledge cycle. On a multiplexed bus the IUSC latches the state of this pin at rising edges on */AS*; on a non-multiplexed bus, it latches */CS* at leading/falling edges on */DS*, */RD*, or */WR*.

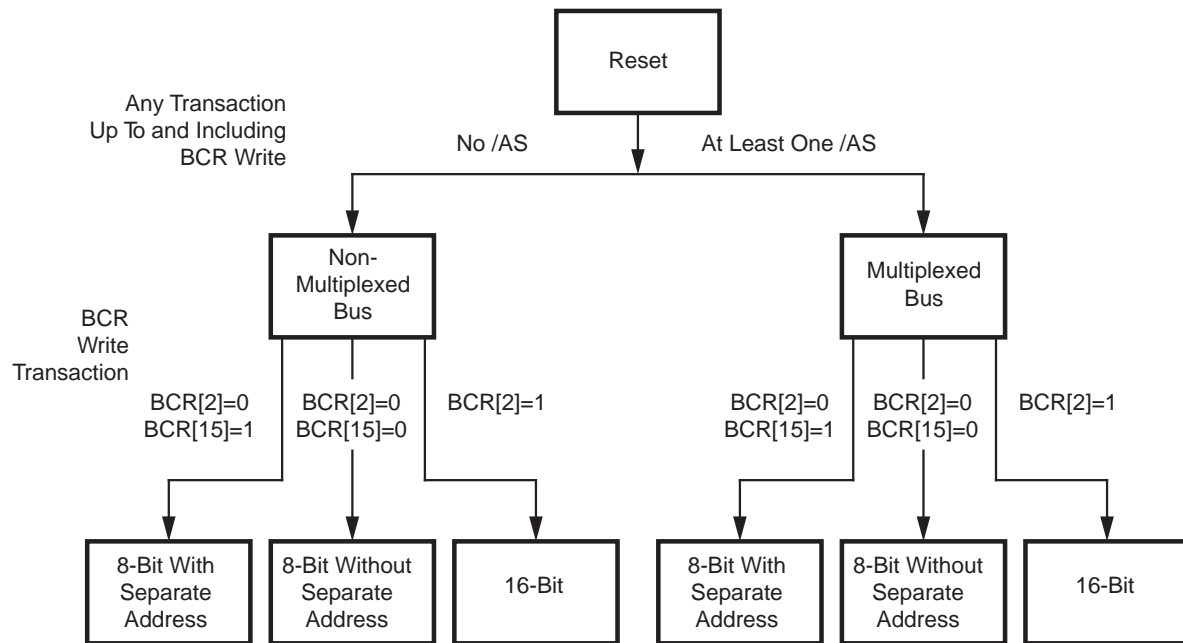

Note:
The presence of one transaction with an /AS active between reset, up to and including the BCR write, chooses a multiplexed type of bus.

Figure 5. BCR Reset Sequence and Bit Assignments

/RD Read Strobe (input/tri-state output, active Low). This line indicates a read cycle on the bus, for host processors/buses having this kind of signalling. It is an output when the IUSC has taken control of the bus and is operating in master mode, otherwise, it is an input that is qualified by /CS Low or /INTACK Low. For master read cycles, the IUSC captures data at the rising (trailing) edge of this line. For slave read cycles the IUSC provides valid data on the AD lines within the specified access time after this line goes Low, and keeps the data valid until after the master releases this line to High.

/WR Write Strobe (input/tri-state output, active Low). This line indicates write cycles on the bus, for host processors/buses having this kind of signalling. It is an output when the IUSC has taken control of the bus and is operating in master mode, otherwise it is an input that is qualified by /CS Low. For slave write cycles, the IUSC captures write data at the rising (trailing) edge of this line. For master write cycles, the IUSC places valid data on the AD lines before it drives this signal to Low, and keeps the data valid until after it drives this line back to High.

B/W Byte / Word Select (tri-state output, High indicates 8-bit transfer). When the IUSC takes control of the bus and operates as a master, a High on this line indicates that a byte is to be transferred, and a Low indicates that 16 bits are to be transferred. The IUSC ignores this signal during slave cycles: it takes the byte/word distinction from an AD line at the rising edge of /AS, or from a bit in the serial or DMA Command/Address Register.

/WAIT//RDY Wait, Ready, or Acknowledge handshaking (input/tri-state output, active Low). This line is an input when the IUSC has taken control of the bus and is operating in master mode. For slave cycles, the IUSC activates this line as an output. In both directions, the line can carry wait or acknowledge signalling depending on the state of the S//D input during the initial BCR write. If S//D is High when the BCR is written, this line operates as a Ready/Wait line for Zilog and most Intel processors. In this mode, the IUSC will not complete a master cycle while this line is Low, and it asserts this line Low until it's ready to complete an interrupt acknowledge cycle; it never asserts this line when the host accesses one of the IUSC registers.

If S//D is Low when the BCR is written, this line operates thereafter as an Acknowledge line for Motorola and some Intel processors. In this mode, the IUSC will not complete a master cycle until this line is Low. It asserts this line Low for register read and write cycles, and when it is ready to complete an interrupt acknowledge cycle.

For slave cycles, this is a full time (totem pole) output. The board designer can combine this signal with similar signals from other slaves, by means of an external logic gate or a tri-state or open-collector driver.

/INT Interrupt Request (output, active Low). The IUSC drives this line Low when (1) its IEI pin is High, (2) one or more of its interrupt condition(s) is (are) enabled and pending, and (3) the Under Service flag is not set for its highest priority enabled/pending condition, nor for any higher-priority internal condition. Software can program whether the bus interface drives this pin in a totem-pole or an open-drain fashion.

/INTACK Interrupt Acknowledge (input, active Low). A Low on this line indicates that the host processor is performing an interrupt acknowledge cycle. In some systems, a Low on this line may further indicate that external logic has selected this IUSC as the device to be acknowledged, or as a potential device to be acknowledged. A field in the Bus Configuration Register selects whether this line carries a level-sensitive "status" signal that the IUSC should sample at the leading edge of /AS or /DS, or a single-pulse or double-pulse protocol. The IUSC responds to an interrupt acknowledge cycle in a variety of ways depending on this programming and the state of the /INT and IEI lines, as described in the text.

IEI Interrupt Enable In (input, active High). This signal and the IEO pin can be part of an interrupt-acknowledge daisy chain with other devices that may request interrupts. If IEI is High outside of an interrupt acknowledge cycle, one or more IUSC interrupt condition(s) is (are) enabled and pending, and the Under Service flag isn't set for the highest priority condition nor for any higher-priority one, then the IUSC requests an interrupt by driving its /INT pin Low. If the IEI pin is High during an interrupt acknowledge cycle, one or more IUSC interrupt condition(s) is (are) enabled and pending, and the Under Service flag isn't set for the highest priority condition nor for any higher-priority, then the IUSC keeps IEO Low and responds to the cycle.

IEO Interrupt Enable Out (output, active High). This signal and/or IEI can be part of an interrupt acknowledge daisy chain with other devices that may request interrupts. The IUSC drives its IEO pin Low whenever its IEI pin is Low, and/or if the Under Service flag is set for any condition. This IUSC drives this signal slightly differently during an interrupt acknowledge cycle, in that it also forces IEO Low if it is (has been) requesting an interrupt.

PIN DESCRIPTION (Continued)

/BUSREQ *Bus Request* (output, active Low). The DMA controller section drives this line Low to request control of the host bus. /BUSREQ can be an open-drain or totem-pole output depending on a bit in the Bus Configuration Register. In open-drain mode the IUSC samples the pin as an input and only drives it Low after sampling it high.

/BIN *Bus Acknowledge In* (input, active Low). When the IUSC receives a falling edge on this input, it samples whether it has been driving (or has just begun to drive) /BUSREQ. If so, it keeps /BOUT High and takes control of the host bus. If not, it passes the bus grant by driving /BOUT Low. This signal can be used with /BOUT to form a bus-grant daisy chain for arbitration of bus control. Alternatively, it can be connected to a direct, positive grant from an external arbiter, and the /BOUT pin can be left unconnected.

/BOUT *Bus Acknowledge Out* (output, active Low). As noted above, this signal can be used with /BIN to form a bus-grant daisy chain for arbitration of bus control.

/ABORT *Abort Master Cycle* (input, active Low). A Low on this line during a master cycle makes the currently active DMA channel terminate its activity and enter a disabled state. Note that /ABORT is only effective during a DMA cycle, so that the IUSC knows which channel should be aborted. Also note that external logic must set /WAIT//RDY to the right state for the cycle to complete, before /ABORT becomes effective.

RxD *Received Data* (input, positive logic). The serial input.

TxD *Transmit Data* (output, positive logic). The serial output.

/RxC *Receive Clock* (input or output). This signal can be used as a clock input for any of the functional blocks in the serial controller. Or, software can program the IUSC so that this pin is an output carrying any of several receiver or internal clock signals, a general-purpose input or output, or an interrupt input.

/TxC *Transmit Clock* (input or output). This signal can be used as a clock input for any of the functional blocks in the serial controller. Or, software can program the IUSC so that this pin is an output carrying any of several transmitter or internal clock signals, a general purpose input or output, or an interrupt input.

/RxREQ *Receive DMA Request* (input or output). In device testing or in applications not using the serial controller and DMA controller sections together in the usual way, this pin can carry an active Low DMA Request from the receive FIFO. On the IUSC this request is internally routed to the on-chip Receive DMA channel; it is more typical to use the RxREQ pin as a general-purpose output or as an interrupt input.

/TxREQ *Transmit DMA Request* (input or output). In device testing or in applications not using the serial controller and DMA controller sections together in the usual way, this pin can carry an active Low DMA Request from the transmit FIFO. On the IUSC this request is internally routed to the on-chip Transmit DMA channel, and it's more typical to use the RxREQ pin as a general-purpose output or as an interrupt input.

/DCD *Data Carrier Detect* (input or output, active Low). Software can program the IUSC so that this signal enables/disables the receiver. In addition, software can program the device to request interrupts in response to transitions on this line. The pin can also be used as a simple input or output.

/CTS *Clear to Send* (input or output, active Low). Software can program the IUSC so that this signal enables/disables the transmitter. In addition, software can program the device to request interrupts in response to transitions on this line. The pin can also be used as a simple input or output.

PORT7/TxCOMPLT *General-Purpose I/O or Transmit Complete* (input or output). Software can program the IUSC so that this pin is a general-purpose input or output, or so that it carries a Transmit Complete signal from the Transmitter, that can control an external driver. The IUSC captures transitions on this pin in internal latches.

PORT6/FSYNC *General-Purpose I/O or Frame Sync* (input or output). Software can program the IUSC so that this pin is a general-purpose input or output, or a Frame Sync input for the IUSC's Time Slot Assigner circuits. The IUSC captures transitions on this pin in internal latches.

PORT5/RxSYNC *General-Purpose I/O or Receive Sync* (input or output). Software can program the IUSC so that this pin is a general-purpose input or output, or so that it carries a Receive Sync output from the Receiver. The IUSC captures transitions on this pin in internal latches.

PORT4/TxTSA *General-Purpose I/O or Transmit Time Slot Assigner Gate* (input or output). Software can program the IUSC so that this pin is a general-purpose input or output, or so that it carries the Gate output of the Transmit Time Slot Assigner, that can enable an external TxD driver in time-slotted ISDN or Fractional T1 applications. The IUSC captures transitions on this pin in internal latches, as described in the text.

PORT 3/RxTSA *General-Purpose I/O or Receive Time Slot Assigner Gate* (input or output). Software can program the IUSC so that this pin is a general-purpose input or output, or so that it carries the Gate output of the Receive Time Slot Assigner. The IUSC captures transitions on this pin in internal latches.

PORT 2 *General-Purpose I/O* (input or output). Software can program the IUSC so that this pin is a general-purpose input or output. The IUSC captures transitions on this pin in internal latches.

PORT 1-0/CLK 1-0 *General-Purpose I/Os or Reference Clocks* (inputs or outputs). Software can program the IUSC so that either of these pins is a general-purpose input or output, or a reference clock that can be divided down to derive clocking for the Receiver and/or Transmitter. When one of these pins is a general-purpose I/O, the IUSC captures transitions on it in internal latches.

V_{CC}, V_{SS} *Power and Ground*. The inclusion of seven pins for each power rail ensures good signal integrity, prevents transients on outputs, and improves noise margins on inputs. The IUSC's internal power distribution network requires that all these pins be connected appropriately.

ARCHITECTURE

The IUSC integrates a fast and efficient dual-channel DMA with a highly versatile serial communications controller. The functional capabilities of the IUSC are described from two different points of view; as a datacommunications device, it transmits and receives data in a wide variety of datacommunications protocols; as a microprocessor peripheral with two DMA channels that offer such features as

four DMA transfer types, a flexible bus interface, and vectored interrupts. The architecture is described in three sections, DMA and Bus Interface Capabilities, Communication between the DMA and Serial Channel, and Serial Communication Capabilities. The structure of the IUSC is shown in Figure 1.

DMA AND BUS INTERFACE CAPABILITIES

The IUSC's two versatile DMA channels combined with a flexible bus interface gives it the ability to meet a wide variety of application requirements. The time required to move data into and out of the transmitter and receiver is minimized by the IUSC's speed (20 MHz clock, three clock cycles per word, typical); two buffer-chaining modes with linked-frame status transfer; early buffer termination to keep received frames in separate memory buffers; and vectored interrupts. Some of these features are briefly described below, however, the user should refer to the IUSC Technical Manual for additional information.

DMA Modes

The IUSC contains two DMA channels, one for the transmitter and one for the receiver. Each channel supports a 32-bit address and a 16-bit byte count. The channels operate in one of four modes. In normal mode, the processor must reload the address and length at the end of each buffer. In Pipelined mode, the processor can load the address and length of the next buffer at any time during the DMA transfer to the first buffer. In Array-Chained mode the processor creates a table of address/length pairs in memory for automatic transfer by the channel. In Linked List mode the processor creates a linked list of address and length pairs in memory to be automatically transferred by the channel.

Single Buffer Mode is the most basic of the four data transfer types. The starting address of each memory buffer and the maximum number of characters to be transferred to or from memory are programmed into the IUSC registers. When the DMA is enabled, it transfers all data between system memory and the transmit and receive FIFOs.

Pipelined Mode is similar to Single Buffer Mode with the addition of an extra set of registers into which the processor can load to reload the DMA with the address and count of the next memory buffer. Therefore, when a buffer is complete, the IUSC is pre-programmed with the address and count of the next buffer so the DMA need not stop between each buffer as long as software stays one step ahead of memory buffer usage.

In Array Mode, one of the two chaining modes, software sets up a table of memory buffer information. The length of the array is only limited by the amount of system memory available for buffers. The IUSC is programmed with the location of the array of buffer addresses and sizes. This mode has the advantage that a burst of short frames is less

likely to overrun the systems ability to keep up. The use of receive status block and transmit control block along with the early buffer termination feature simplifies the segmentation and reassembly of serial messages in memory buffers. When a DMA channel fetches a buffer count of zero, it stops and can create an End-Of-Array interrupt.

Linked List Mode is the most versatile of DMA modes. It has the Array Mode's ability to switch buffers rapidly without the requirement for the buffer information to be in a continuous table. Each link entry contains: The starting address to write or read the data; the size of the buffer; optional status or control information; and a pointer to the next link. Memory buffers can easily be added and removed from the list by changing the links in list entries.

DMA Features

In Linked List Mode, the IUSC has a programmable feature to facilitate the use of buffers in a ring. When this feature is enabled, the DMA writes a zero back to the buffer length field of each array or list entry after it is read. Therefore, if a linked list wraps around on itself, a DMA channel will not reuse a buffer until software has processed the buffer, and indicated that its eligible for reuse by writing a nonzero value in the count field (fetching a count value of zero deactivates the DMA channel). This feature can also be used in array mode to track buffer use.

In both Bus Slave and Master Modes, the IUSC can read and write data words in either byte order. It supports the Little Endian convention used by many Intel microprocessors and the Big Endian convention used by many Motorola microprocessors. When the IUSC is bus master, it can be programmed to generate only the upper 16-bit address when required and, consequently, save a clock cycle on each transfer (three clocks per transfer instead of four). When using the IUSC on a 16-bit bus and the starting address of the message is on an odd address, the IUSC automatically reorients itself onto even word boundaries by first fetching a byte. This is especially valuable when retransmitting a frame with a different size header than was received. Two pins are available as status signals of the type of transfer in progress.

There are a variety of command and status registers to control and monitor the DMA channels. A DMA channel can be aborted with either the /ABORT pin or by software command. A pause command is also available to temporarily suspend transfers.

Bus Interface & Utilization

The bus interface module stands between the external bus pins and an on-chip 16-bit data bus that interconnects the other functional modules. It includes several flexible bus interfacing options that are controlled by the contents of the Bus Configuration Register (BCR). The BCR is automatically the destination of the first write to the IUSC by the host processor after a reset.

The IUSC is compatible with both multiplexed and non-multiplexed bus interfaces and can transfer either 8 or 16 bits. It supports data transfers with /RD and /WR or R//W and /DS strobe pins and either format of byte ordering. The IUSC generates the Wait or Ready acknowledge handshaking used by Intel or Motorola microprocessors. Also, three styles of interrupt acknowledge signals are supported for automated return of an interrupt vector to any common microprocessor.

There are several options that control how the IUSC uses the bus. The /BIN and /BOUT pins are available to form a bus-grant daisy chain. The IUSC has several options on how it arbitrates requests for bus mastership between channels and how long it stays off the bus between requests. The priority of the two DMA channels is programmable and can alternate between requests to allow both channels equal access to the bus. Once one of the channels has mastership of the bus, control can be passed to the other channel if it is requesting or the IUSC can be forced off the bus. A programmable preempt feature selects whether the higher priority channel can take over control of the bus if it starts requesting control while the lower priority channel is using the bus.

The IUSC maximizes the use of its 32-byte FIFOs by holding /BUSREQ active until the transmit FIFO is full, the receive FIFO is empty, or both. The programmable dwell timers can be used to limit how long the IUSC holds bus mastership by counting either bus transfers, clock cycles or both. Therefore, the combination of programmable FIFO request levels, channel arbitration options, and programmable dwell timer features provide application software the flexibility to optimize the IUSCs bus occupancy to meet system throughput and bus response requirements.

Interrupts

The interrupt subsystem of the IUSC derives from Zilog's experience in providing the most advanced interrupt capabilities in the microprocessor field. These capabilities are at their best when used with a Zilog microprocessor, but it is easy to interface the IUSC to work well with other microprocessors as well. Four pins are dedicated to create an interrupt daisy-chain hierarchy within the Serial Channel and between the Serial Channel and the DMA.

When an IUSC responds to an interrupt acknowledge from the CPU, it places an interrupt vector on the data bus. To speed interrupt response time, the IUSC modifies three bits in the vector to indicate which type of interrupt is being requested. Separate vectors are provided for the serial channel and DMA to easily discriminate the interrupt source.

The DMA has four interrupt sources each for the receive and transmit channels. Each interrupt source is independently enabled and there is a master enable for all DMA interrupts. The four interrupt sources are End Of Array/ End of Link, End Of Buffer, Hardware Abort, and Software Abort.

Each of the six types of interrupts in the serial portion IUSC (Receive Status, Receive Data, Transmit Status, Transmit Data, I/O Status and Device Status) has three bits associated with it: Interrupt Pending (IP), Interrupt-Under-Service (IUS) and Interrupt Enable (IE). If the IE bit for a given source is set, then that bit can source request interrupts. Note that individual sources within the six types also have their own interrupt arm bits. Finally, there is a Master Interrupt Enable (MIE) bit which globally enables or disables all interrupts from the serial channel.

The Interrupt (/INT), Interrupt Acknowledge (/INTACK), Interrupt Enable In (IEI) and Interrupt Enable Out (IEO) pins are provided to create an automated mechanism to place the vector on the bus among the highest priority pending interrupts from multiple devices. The device with the highest pending interrupt (/INT Low, IEI High) places a vector on the bus in response to an interrupt acknowledge cycle.

In the IUSC, the IP bit signals that an interrupt is pending. If an IUS bit is set, this interrupt is being serviced and all interrupt sources of lower priority are prevented from requesting interrupts. An IUS bit is set during an interrupt acknowledge cycle if there are no higher priority devices requesting interrupts.

DMA AND BUS INTERFACE CAPABILITIES (Continued)

There are six sources of Receive Status interrupt. Each one is individually armed: Receiver exited hunt, received idle line, received break/abort, received code violation/end-of-transmission/end-of-message, parity error/abort and overrun error. The Receive Data interrupt is generated whenever the receive FIFO fills with data beyond the level programmed in the Receive Interrupt Control Register (RICR). There are six sources of Transmit Status interrupt. Each one is individually armed: Preamble sent, idle line sent, abort sent, end-of-frame/end-of-message sent, CRC sent and underrun error. The Transmit Data interrupt is generated whenever the transmit FIFO empties below the level programmed in the Transmit Interrupt Control Register (TICR).

The I/O Status interrupt serves to report transitions on any of six pins. Interrupts are generated on either or both edges with individual edge selection and arming for each pin. The pins that can be programmed to generate I/O Status interrupts are /RxC, /TxC, /RxREQ, /TxREQ, /DCD and /CTS. These interrupts are independent of the programmed function of the pins.

The Device Status interrupt has four individually enabled sources: Receive character counter underflow, DPLL sync acquired, BRG1 zero count and BRGO zero count. Refer to the IUSC Technical Manual for more details.

COMMUNICATION BETWEEN THE DMA AND SERIAL CHANNELS

The IUSC's intra-chip communication between the DMA and serial communications controller gives it the power to achieve higher efficiency than is possible with a separate DMA controller. The Linked Frame Status Transfer feature writes the status and byte count of each received frame to memory as part of an array or linked list. This provides a simple and easy to use mechanism for storing the results of a received message without arbitrary restrictions on how quickly the host software must examine the results. Similarly, control information for transmit frames can be automatically read by the DMA from the array or link and transferred into registers in the serial logic.

In all modes, the DMA can accept a signal from the serial channel for early buffer termination. When the end of a message is received, the data is transferred to the buffer and the status is written to memory. The status is written after the data in single buffer and pipelined modes or to the array/link in array and linked-list modes if Linked-Frame Status Transfer is enabled. This early buffer termination is

treated identically to the terminal count condition in the DMA. Therefore, the receipt of the end of a message is a seamless transition from one memory buffer to the next.

An example of using these intercommunication features using linked list mode is shown in Figure 5. This example shows the format of a ring of memory buffers with the linked frame status transfer and ring buffer features enabled. Any protocol that sets the "RxBound" bit (RCSR4 = 1), like HDLC or 802.3, is appropriate to this example. The linked list is shown in Figure 5 with three links for simplicity and may be as large as memory allows. The sixth word in each list entry is reserved and should not be used (it keeps the list entries on 32-bit boundaries). If the end of the buffer is reached and it is not the end of the frame, the IUSC writes zeros as the status and count. Also, if the transmit channel needs to start a new memory buffer other than at the beginning of a frame, the DMA ignores the transmit control block.

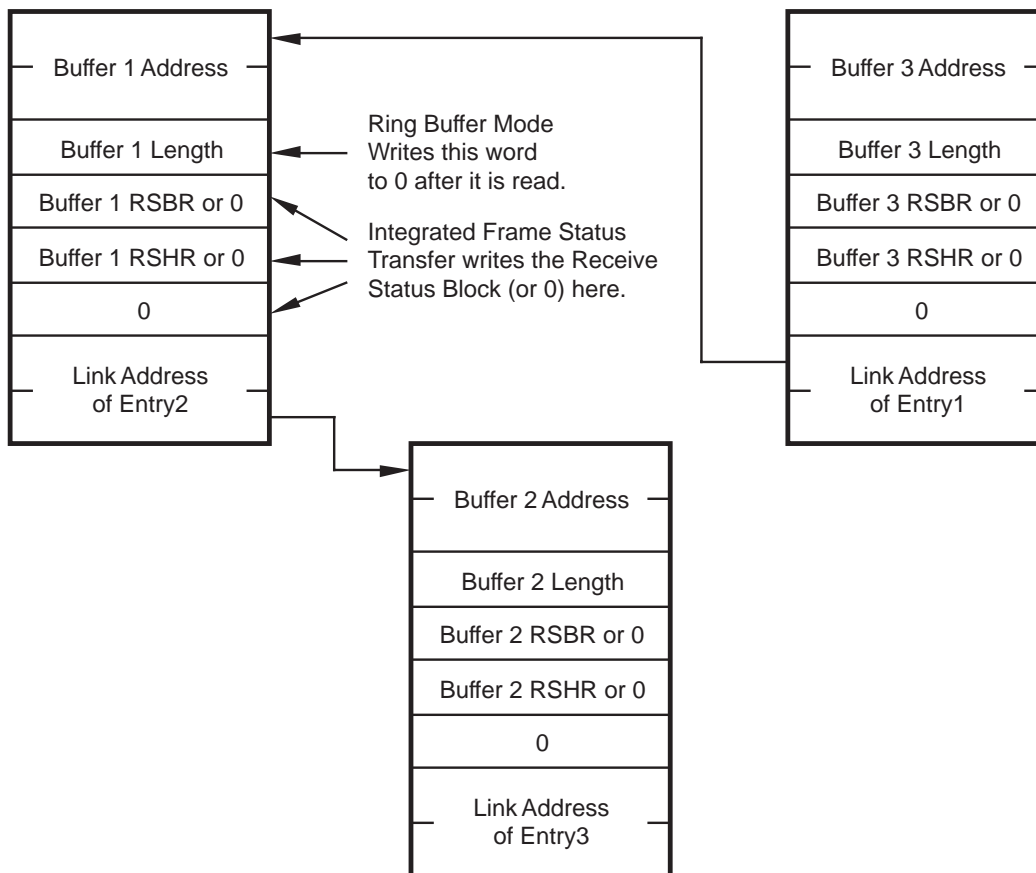

Figure 5. Linked List Mode with Linked Frame Status Transfer and Ring Buffer Features

Another method by which the DMA and serial channel work together is using the Transmit Character Counter to break a large block of data into a number of fixed length frames. For example, it is desired to transmit a large file which is located in several memory buffers as fixed length smaller frames. With the IUSC, the serial channel is programmed to send the end-of-frame sequence each time the set number of bytes is transmitted. Therefore, DMA transfers are not interrupted, nor is system response required to break the large file into frames.

The IUSC provides higher throughput than discrete serial and DMA chip solutions because discrete chips do not directly communicate with each other and, therefore, the status of one device must be read by the CPU and communicated to the other. This typically requires interrupts and the suspension of activity until status/control information is updated. This uses precious time and bus bandwidth, which can limit total throughput.

DATA COMMUNICATIONS CAPABILITIES

The IUSC provides a full-duplex channel programmable for use in any common data communication protocol. The receiver and transmitter are completely independent and each is supported by a 32-byte deep FIFO and a 16-bit frame length counter. All modes allow optional even, odd, mark or space parity. Synchronous modes allow the choice of either of two 16-bit or a 32-bit CRC polynomials. Character length of up to 8 bits can be programmed for the receiver and transmitter independently. Error and status conditions are carried with the data in the receive FIFO to greatly reduce the CPU overhead required to send or receive a message, while key control parameters accompany transmit characters through the Tx FIFO. Interrupts can be individually armed to signal such conditions as overrun, parity error, framing error, end-of-frame, idle line received, sync acquired, transmit underrun, CRC sent, closing sync/flag sent, abort sent, idle line sent and preamble sent. In addition, several useful internal signals like receive character boundary, received sync, transmit character boundary and transmission complete can be sent to pins for use by external circuitry.

Protocols

Asynchronous Mode. The receiver and transmitter handle data at a rate of 1/16, 1/32, or 1/64 the clock rate. The receiver rejects start bits less than one-half a bit time and includes recovery logic following a framing error. The transmitter is capable of sending one, two, or anywhere in the range of 9/16th to two stop bits per character in 1/16 bit increments.

Nine-Bit Mode. This mode is identical to async except that the receiver checks for the status of an additional address/data bit between the parity bit and the stop bit. The value of this bit is FIFO'ed along with the data. In the transmitter, this bit is automatically inserted with the value that is FIFO'ed from the transmit data.

Isochronous Mode. Both transmitter and receiver operate on start-stop (async) data using a 1x clock. The transmitter sends one or two stop bits.

Asynchronous With Code Violations. This is similar to Isochronous mode except that the start bit is replaced by a three bit-time code violation pattern as in MIL-STD-1553B. The transmitter sends zero, one or two stop bits.

HDLC Mode. In this mode, the receiver recognizes flags, performs optional address matching, accommodates extended address fields, and performs zero deletion and CRC checking. The receiver is capable of receiving shared-zero flags, recognizes abort sequences and can receive arbitrary length frames. The transmitter automatically sends

opening and closing flags, performs zero insertion and can be programmed to send an abort, an extended abort, a flag or CRC and a flag on transmit underrun. The transmitter automatically sends a closing flag with optional CRC at the end of a programmed message length. Shared-zero flags are selected in the transmitter and a separate character length is programmed for the last character in the frame.

Frames terminated with an ABORT can be marked with a status bit on the preceding character in addition to the status interrupt that can be enabled. Abort is only detected in-frame and, therefore, eliminates false detection due to an idle line. The IUSC provides four choices (flag, all 1s, all 0s, or alternating 1s and 0s) of line preamble to condition the line before beginning data transmission. This feature is valuable to get the receiver DPLL in sync and as a flow control mechanism to slow down frame transmission without slowing down the clock or disabling the transmitter.

HDLC Loop Mode. This mode is available only in the transmitter and allows the IUSC to be used in an HDLC Loop configuration. In this mode, the receiver is programmed to operate in HDLC mode to allow the transmitter to echo received messages. Upon receipt of a particular bit pattern (actually a sequence of seven consecutive ones) the transmitter stops repeating data and inserts its own frame(s).

802.3 Mode. This mode implements the data format of IEEE 802.3 with a 16-bit address compare. In this mode, /DCD and /CTS are used to implement the carrier sense and collision detect interactions with the receiver and transmitter. Back-off timing must be provided externally.

Monosync Mode. In this mode, a single character is used for synchronization. The sync character can be either eight bits long or the same length as the data characters. The receiver can automatically strip sync characters from the received data stream. The transmitter is programmed to automatically send CRC on either an underrun or at the end of a programmed message length.

Slaved Monosync Mode. This mode is available only in the transmitter and allows the transmitter (operating just as though it were in monosync mode) to send data with its byte boundaries synchronized to those of the received data.

Bisync Mode. This mode is identical to monosync mode except that character synchronization requires two successive characters. The two characters need not be identical.

Transparent Bisync Mode. In this mode, the synchronization pattern is DLE-SYN, programmable selected from either ASCII or EBCDIC encoding. The receiver recognizes control character sequences and automatically handles CRC calculations without CPU intervention. The transmitter is programmed to send either SYN, DLE-SYN, CRC-SYN, or CRC-DLE-SYN upon underrun and automatically sends the closing DLE-SYN with optional CRC at the end of a programmed message length.

External Sync Mode. The receiver is synchronized to the receive data by an externally-supplied signal on a pin for custom protocol applications.

Data Encoding

The IUSC is programmed to encode and decode the serial data in any of eight different ways (Figure 6). The transmitter encoding method is selected independently of the receiver decoding method.

NRZ. In NRZ, a 1 is represented by a High level for the duration of the bit cell and a 0 is represented by a Low level for the duration of the bit cell.

NRZB. NRZB is inverted from NRZ.

NRZI-Mark. In NRZI-Mark, a 1 is represented by a transition at the beginning of a bit cell, i.e., the level present in the preceding bit cell is reversed. A 0 is represented by the absence of a transition at the beginning of the bit cell.

NRZI-Space. In NRZI-Space, a 1 is represented by the absence of a transition at the beginning of a bit cell, i.e., the level present in the preceding bit cell is maintained. A 0 is represented by a transition at the beginning of the bit cell.

Biphase-Mark. In Biphase-Mark, a 1 is represented by a transition at the beginning of the bit cell and another transition at the center of the bit cell. A 0 is represented by a transition at the beginning of the bit cell only.

Biphase-Space. In Biphase-Space, a 1 is represented by a transition at the beginning of the bit cell only. A 0 is represented by a transition at the beginning of the bit cell and another transition at the center of the bit cell.

Biphase-Level. In Biphase-Level, a 1 is represented by a High during the first half of the bit cell and a Low during the second half of the bit cell. A 0 is represented by a Low during the first half of the bit cell and a High during the second half of the bit cell.

Differential Biphase-Level. In Differential Biphase-Level, a 1 is represented by a transition at the center of the bit cell, with the opposite polarity from the transition at the center of the preceding bit cell. A 0 is represented by a transition at the center of the bit cell with the same polarity as the transition at the center of the preceding bit cell. In both cases, there are transitions at the beginning of the bit cell to set up the level required to make the correct center transition.

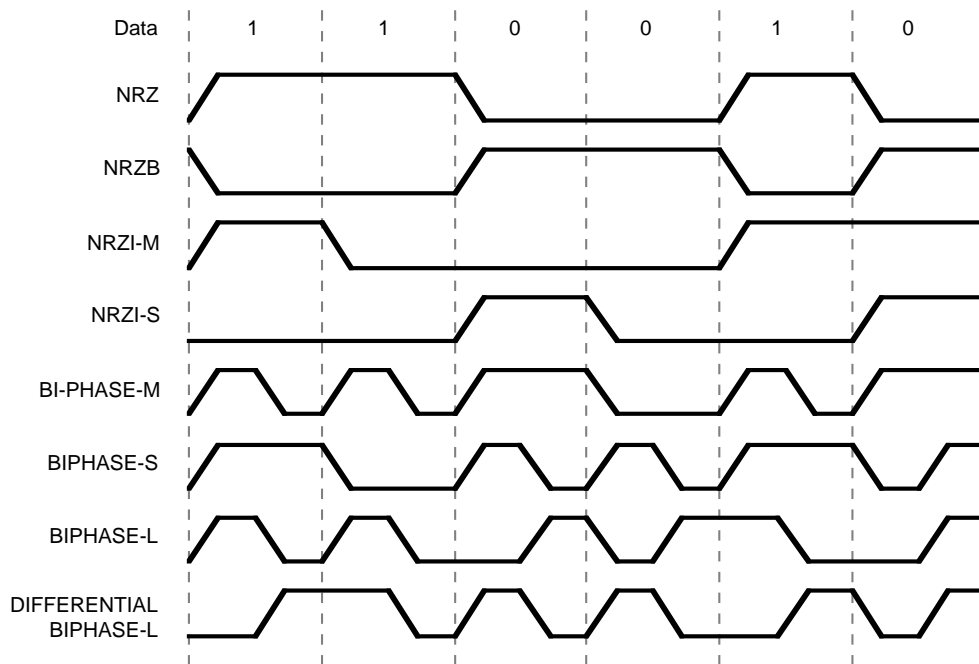

Figure 6. Data Encoding

DATA COMMUNICATIONS CAPABILITIES (Continued)

Character Counters

The IUSC contains separate 16-bit character counters for the receiver and transmitter. The receive character counter is set to a programmable starting value or automatically at the beginning of each received frame and can be reloaded under software control during a frame. The counter decrements with each receive character. At the end of the receive message the current value in the counter is automatically loaded into a four-deep FIFO. With the Receive Status Block (RSB) feature enabled, the counter value and the status (RCSR) can be automatically transferred to memory following the data. In array and linked list modes, the RSB can be transferred to the array or list entry for easy software access. This allows DMA transfer of data to proceed without CPU intervention at the end of a received frame, as the values in the FIFO allow the CPU to determine the status and length of each frame.

Similarly, the transmit character counter is loaded automatically at the beginning of each transmit frame and can be reloaded under software control during a frame. The counter is decremented with each write to the transmit FIFO. When the counter reaches zero, and that byte is sent, the transmitter automatically terminates the message in the appropriate fashion (usually by sending the CRC and the closing flag or sync character) without requiring CPU intervention. In linked list and array modes, the transmit character count and frame control word can be fetched from the linked list or array.

Baud Rate Generators

The IUSC contains two Baud Rate Generators. Each generator consists of a 16-bit time constant register and a 16-bit down counter. In operation, the counter decrements with each cycle of its selected input clock, and the time constant can be automatically reloaded when the count reaches zero. The output of the Baud Rate Generator toggles when the counter reaches a count of one-half of the time constant and again when the counter reaches zero. A new time constant can be written at any time but the new value does not take effect until the next load of the counter. The outputs of both baud rate generators are sent to the clock multiplexer for use internally or externally. The input

to the Baud Rate Generator can be the /TxC pin, the /RxC pin, a PORT pin, or the output of either counter. The baud rate generator output frequency is related to the baud rate generator input clock frequency by the following formula:

$$\text{Output frequency} = \text{Input frequency} / (\text{time constant} + 1).$$

Note: This allows an output frequency in the range of 1 to 1/65536 of the input frequency, inclusive.

The output of either Baud Rate Generator can be used as the transmit or receive clock, the reference clock input to the DPLL circuit, and/or can be output on the /RxC or /TxC pin.

Digital Phase-Locked Loop

The IUSC contains a DPLL (Digital Phase-Locked Loop) to recover clock information from a data stream with NRZI or Biphase encoding. The DPLL is driven by a clock that is nominally 8, 16 or 32 times the receive data rate. The DPLL uses this clock, along with the data stream, to construct a clock for the data. This clock can be routed to the receiver, transmitter, or both, or to a pin for use externally. In all modes, the DPLL counts the input clock to create nominal bit times. While counting, the DPLL watches the incoming data stream for transitions. When a transition is detected, the DPLL may make a count adjustment (during the next counting cycle) to produce an output clock which tracks the incoming bit cells. The DPLL provides properly phased transmit and receive clocks to the clock multiplexer.

Counters

The IUSC contains two 5-bit counters, which are programmed to divide an input clock by 4, 8, 16 or 32. The outputs of these two counters are sent to the clock multiplexer. The counters can be used as prescalers for the Baud Rate Generators. They also provide a stable transmit clock from a common source when the DPLL is providing the receive clock. The PORT0 and PORT1 pins can be used as inputs to the counters.

Clock Multiplexers

The clock multiplexer logic selects the receive and transmit clocks and optional outputs on the /RxC and/or /TxC pin(s). In the Z16C32, the PORT0 and PORT1 pins can be used directly as receive and transmit clocks, as well as being used as inputs to the counters.

Time Slot Assigner

The IUSC is equipped with two Time Slot Assigners to support ISDN and Fractional T1 communications. There is one assigner for the receiver. Each time slot assigner selects one or more time slots within a frame, however, the selected time slots must be contiguous. The first selected time slot is programmable from slot 0 (the first slot) to slot 127 of the frame. The number of concatenated slots is programmable from 1 to 15 (total slots). The time of the first slot can be offset an integral number of clocks. This offset is a delay and is programmable from 0 (no offset) to 7 clocks in increments of one clock (one bit cell). This offset can be used to compensate for delays in frame sync detection logic.

Test Modes

The IUSC can be programmed for local loopback or auto echo operation. In local loopback, the output of the transmitter is internally routed to the input of the receiver. This allows testing of the IUSC data paths without any external logic. Auto echo connects the RxD pin directly to the TxD pin. This is useful for testing serial links external to the IUSC.

I/O Port

The Port pins are general-purpose I/O pins. They are used as additional modem control lines or other I/O functions. Each port bit is individually programmable as general-purpose input, as an output, or for a dedicated input or output function. This programming is done in the Port Control Register. Whether used as inputs or outputs, the port pins can be read at any time.

The dedicated functions of the port pins include Time Slot Assigner gate outputs, transmit complete output, clock inputs, receive sync output, or frame sync input.

The port pins capture edge transitions. Programming for the capture is done using the Port Latched/Unlatch command bits in the Port Status Register. Each port bit is individually controlled. The Latched/Unlatch bit is used as a status signal to indicate that a transition has occurred on the port pin and as a command to open the latches that capture this transition. Both rising edge and falling edge are detected. When a transition is detected, the latch closes, holding the post transition state of the input.

The Latched/Unlatch bit is held at 0 if no transitions occur on the port pin; this bit is set to a 1 when a rising edge or falling edge transition is detected, or immediately after the latch is opened if one or more transitions occurred while the latch was closed. Writing a 0 to the Latched/Unlatch bit has no effect on the latch. Writing a 1 to this bit resets the status bit and opens the latch. To use the port as an input without edge detection, a 1 would be written to the Latched/Unlatch bit to open the latch and then the Port Status Register would be read to obtain the current pin input status.

PROGRAMMING

An Electronic Programmer's Manual (MS DOS based) and a Technical Manual are available to provide details about programming the IUSC. Also included are explanations and features of all registers in the IUSC.

The registers in the IUSC are programmed by the system to configure the channel. Before this can occur, the system must set up the bus interface by writing to the Bus Configuration Register (BCR). The BCR has no specific address and is only accessible after a hardware reset of the device. The first write to the IUSC, after a hardware reset, programs the BCR. From that time on other channel registers can be accessed. No specific address need be presented to the IUSC for the BCR write; the IUSC knows that the first write after a hardware reset is destined for the BCR.

In the multiplexed bus case, all registers are directly addressable through the address latched by /AS at the beginning of each bus cycle. The D//C pin is still used to directly access the receive and send data registers (RDR and TDR) with a multiplexed bus; if D//C is High, the address latched by /AS is ignored and an access of RDR or TDR is performed.

In the non-multiplexed bus case, the channel registers are accessed indirectly using the address pointer in the Channel Command/Address Register (CCAR). The address of the desired register is first written to the CCAR and then the selected register is accessed; the pointer in the CCAR is automatically cleared after this access.

Two more points about the IUSC should be noted here. Channel Reset bit in the CCAR places the channel in the reset state. To exit this reset state either a word of all zeros is written to the CCAR (16-bit bus) or a byte of all zeros is written to the lower byte of the CCAR (8-bit bus). Secondly, after reset, the transmit and receive clocks are disabled. The first thing that should be done in any initialization sequence is a write to the Clock Mode Control Register (CMCR) to select a clock source for the receiver and transmitter.

The Serial/DMA (S//D) pin is used to differentiate between the serial channel and the DMA registers. The DMA registers fall into three logic groupings; common registers that apply to both transmit and receive, transmit registers, and receive registers. The registers for DMA transmit functions and receive functions are symmetric and therefore, a single diagram is shown for each in the following pages. When addressing the DMA registers, the Data/Control (D//C) pin selects between the transmit and receive registers. For example, there is a DMA byte count register for transmit and receive (TBCR and RBCR) at address 10101 with S//D pin Low. The TBCR is selected with the D//C pin Low, and the RBCR is selected with the D//C pin High. The format of these two registers is shown in Figure 21.

The register addressing is shown in Table 2 and the table assumes that the BCR register bit 0 is set to 1. The A5-A1 column in the Table reflects the state of AD5-AD1, AD13-AD9, CCAR5-CCAR1 or DCAR5-DCAR1 as applicable. The bit assignments of the registers are shown in Figures 8 through 81. See the IUSC Technical Manual for details. The register addressing is shown in Table 2 and the bit assignments for the registers are shown in Figure 7.

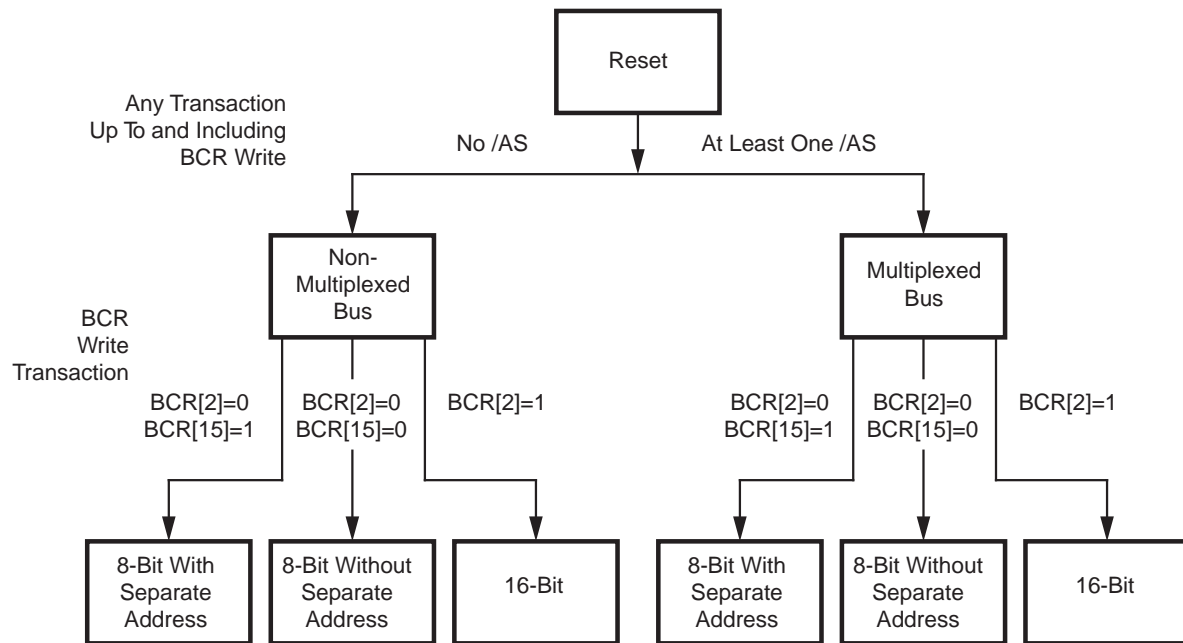

Note:
The presence of one transaction with an /AS active between reset, up to and including the BCR write, chooses a multiplexed type of bus.

Figure 7. BCR Reset Sequence and Bit Assignments

PROGRAMMING (Continued)**Table 1. Register Address List**

S//D	D//C	Address A5-A1	Name	Description
1	0	00000	CCAR	Channel Command/Address Register
1	0	00001	CMR	Channel Mode Register
1	0	00010	CCSR	Channel Command/Status Register
1	0	00011	CCR	Channel Control Register
1	0	00100	PSR	Port Status Register
1	0	00101	PCR	Port Control Register
1	0	00110	TMDR	Test Mode Data Register
1	0	00111	TMCR	Test Mode Control Register
1	0	01000	CMCR	Clock Mode Control Register
1	0	01001	HCR	Hardware Configuration Register
1	0	01010	IVR	Interrupt Vector Register
1	0	01011	IOCR	I/O Control Register
1	0	01100	ICR	Interrupt Control Register
1	0	01101	DCCR	Daisy-Chain Control Register
1	0	01110	MISR	Misc. Interrupt Status Register
1	0	01111	SICR	Status Interrupt Control Register
1	1	XXXXX	RDR	Receive Data Register (Read Only)
1	0	1X000	RDR	Receive Data Register (Read Only)
1	0	10001	RMR	Receive Mode Register
1	0	10010	RCSR	Receive Command/Status Register
1	0	10011	RICR	Receive Interrupt Control Register
1	0	10100	RSR	Receive Sync Register
1	0	10101	RCLR	Receive Count Limit Register
1	0	10110	RCCR	Receive Character Count Register
1	0	10111	TC0R	Time Constant 0 Register
1	1	XXXXX	TDR	Transmit Data Register (Write Only)
1	0	1X000	TDR	Transmit Data Register (Write Only)
1	0	11001	TMR	Transmit Mode Register
1	0	11010	TCSR	Transmit Command/Status Register
1	0	11011	TICR	Transmit Interrupt Control Register
1	0	11100	TSR	Transmit Sync Register
1	0	11101	TCLR	Transmit Count Limit Register
1	0	11110	TCCR	Transmit Character Count Register
1	0	11111	TC1R	Time Constant 1 Register

Table 1. Register Address List (Continued)

S/D	D/C	Address A5-A1	Name	Description
X	0	XXXXX	BCR	Bus Configuration Register
0	X	00000	DCAR	DMA Command/Address Register
0	0	00001	TDCMR	Transmit DMA Channel Mode Register
0	X	00011	DCR	DMA Control Register
0	X	00100	DACR	DMA Array Count Register
0	X	01001	BDCR	Burst Dwell Control Register
0	X	01010	DIVR	DMA Interrupt Vector Register
0	X	01100	DICR	DMA Interrupt Control Register
0	X	01101	CDIR	Clear DMA Interrupt Register
0	X	01110	SDIR	Set DMA Interrupt Register
0	0	01111	TDIAR	Transmit DMA Interrupt Arm
0	0	10101	TBCR	Transmit Byte Count Register
0	0	10110	TARL	Transmit Address Register (Lower)
0	0	10111	TARU	Transmit Address Register (Upper)
0	0	11101	NTBCR	Next Transmit Byte Count Register
0	0	11110	NTARL	Next Transmit Address Register (Lower)
0	0	11111	NTARU	Next Transmit Address Register (Upper)
0	1	00001	RDMR	Receive DMA Mode Register
0	1	01111	RDIAR	Receive DMA Interrupt Arm
0	1	10101	RBCR	Receive DMA Byte Count Register
0	1	10110	RARL	Receive Address Register (Lower)
0	1	10111	RARU	Receive Address Register (Upper)
0	1	11101	NRBCR	Next Receive Byte Count Register
0	1	11110	NRARL	Next Receive Address Register (Lower)
0	1	11111	NRARU	Next Receive Address Register (Upper)

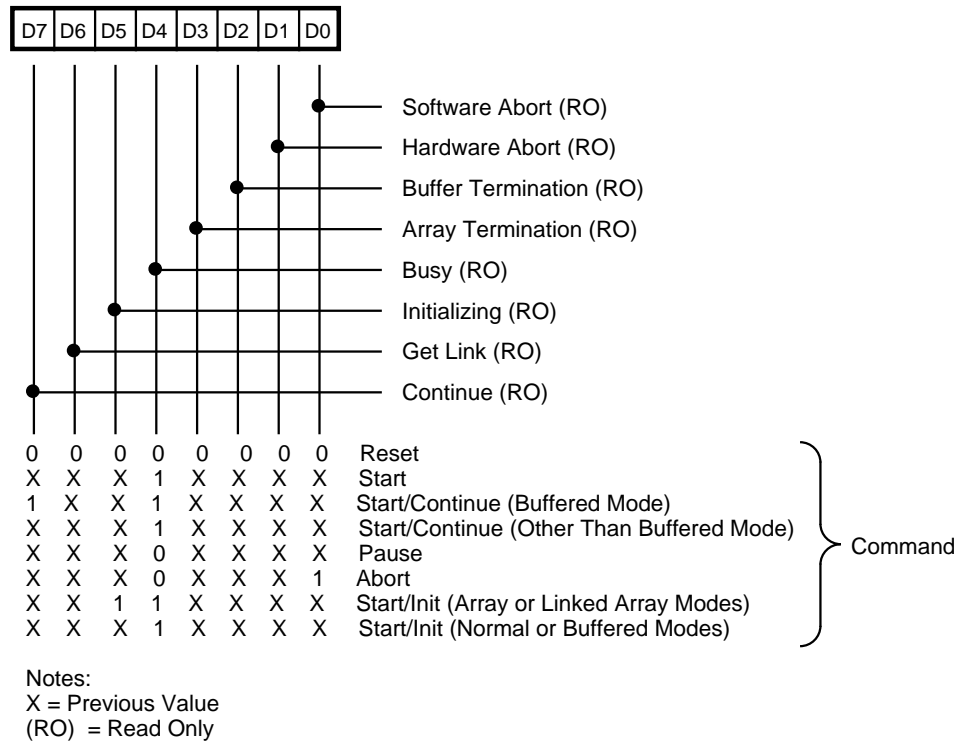

Figure 9. Affect of Commands on Status Bits

CONTROL REGISTERS (Continued)

Address: 00001

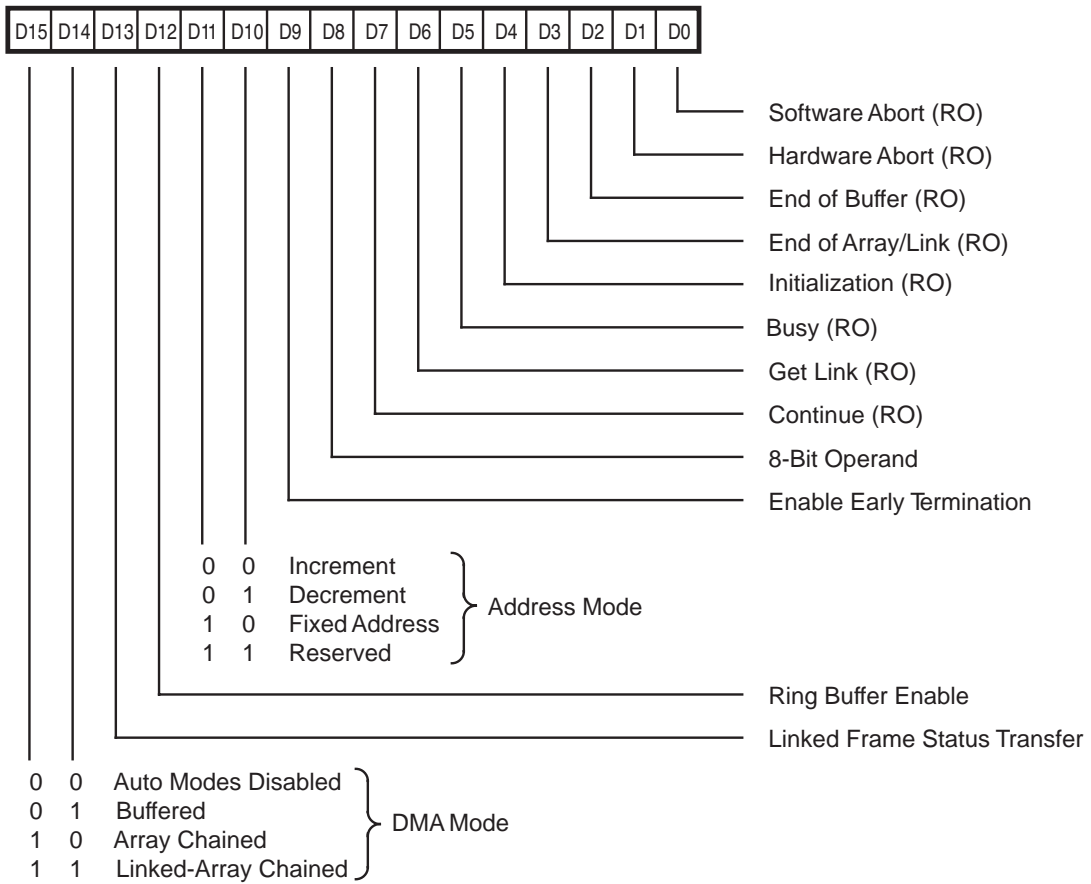

Figure 10. Tx/Rx DMA Mode Register (TDMR) (RDMR)

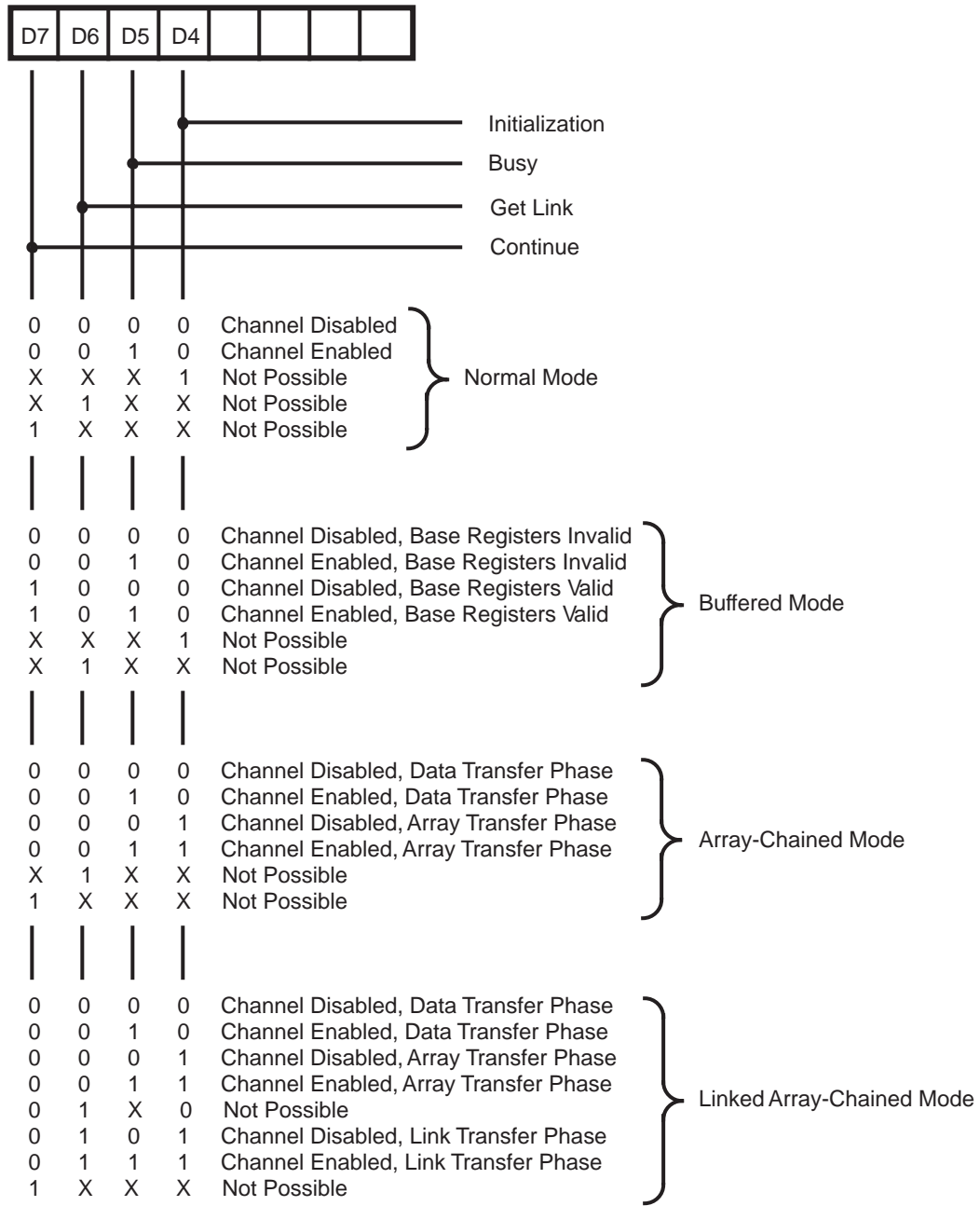

Figure 11. Status Bit Combinations

CONTROL REGISTERS (Continued)

Address: 00011 (Shared)

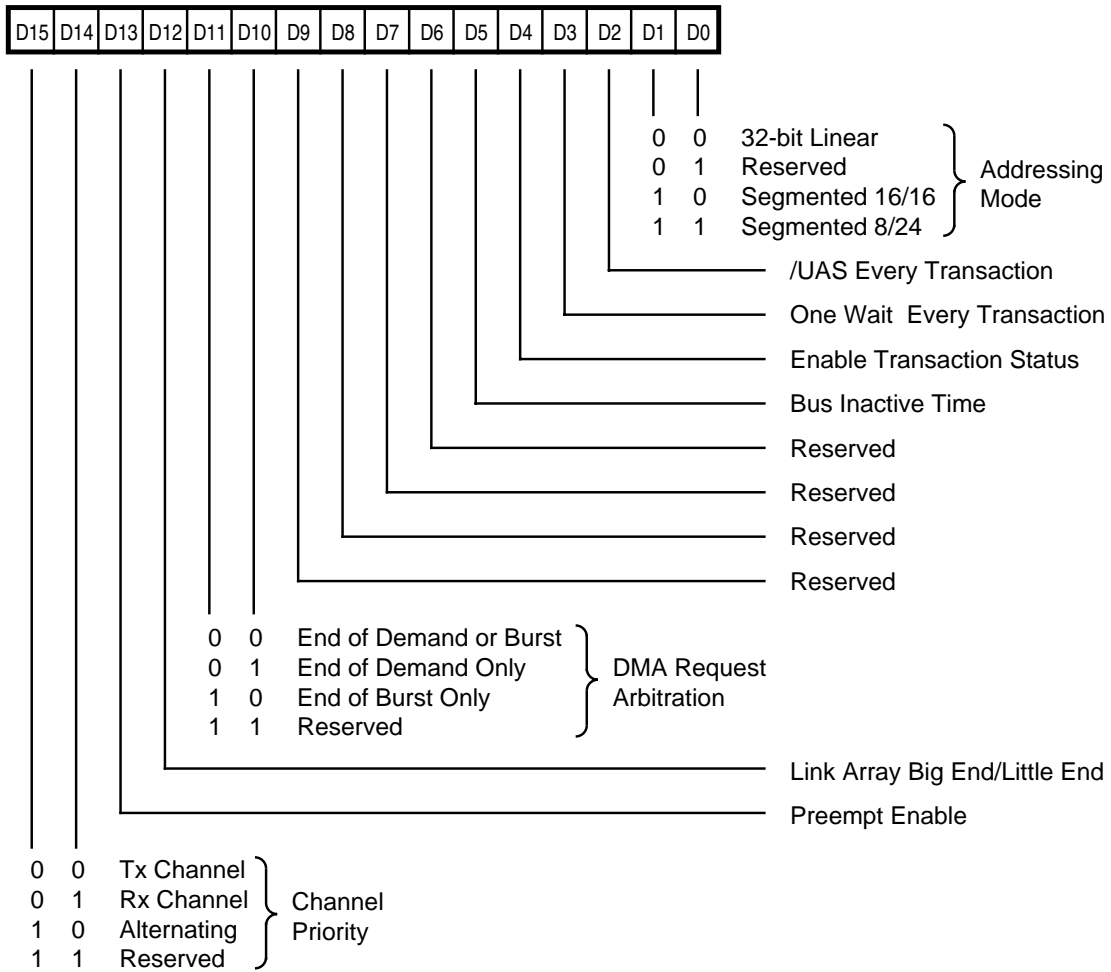

Figure 12. DMA Control Register (DCR)

Big End Array

(16-Bit bus)

AD15

AD0

Address n	31	30	29	28	27	26	25	24	23	22	21	20	19	18	17	16
Address n+2	15	14	13	12	11	10	09	08	07	06	05	04	03	02	01	00

Little End Array

(16-Bit bus)

AD15

AD0

Address n	15	14	13	12	11	10	09	08	07	06	05	04	03	02	01	00
Address n+2	31	30	29	28	27	26	25	24	23	22	21	20	19	18	17	16

Big End Array

(8-Bit bus)

AD7

AD0

Address n	31	30	29	28	27	26	25	24
Address n+1	23	22	21	20	19	18	17	16
Address n+2	15	14	13	12	11	10	09	08
Address n+3	07	06	05	04	03	02	01	00

Little End Array

(8-Bit bus)

AD7

AD0

Address n	07	06	05	04	03	02	01	00
Address n+1	15	14	13	12	11	10	09	08
Address n+2	23	22	21	20	19	18	17	16
Address n+3	31	30	29	28	27	26	25	24

Figure 13. Array-Chained Bit Ordering**Note:**

Bit 12 in DCR is used to control the byte ordering of addresses and counts stored in memory in the Array and Linked Array Modes. The above figure shows the two cases for both bus bandwidths.

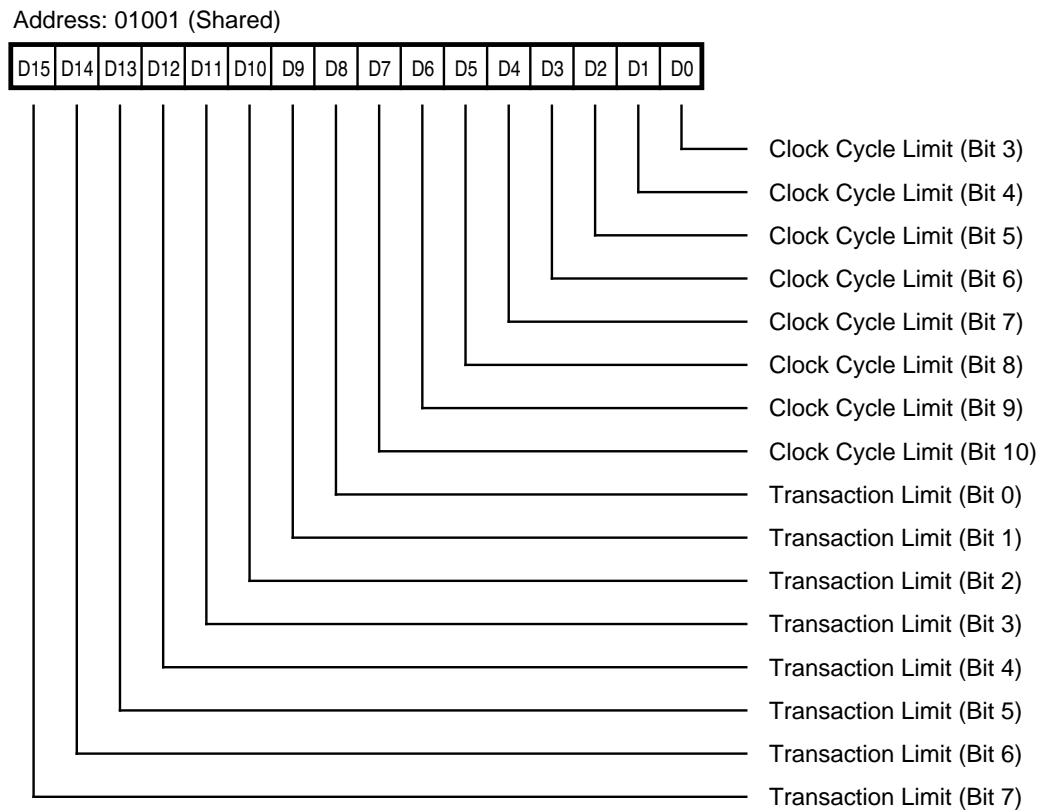

Figure 15. Burst Dwell Control Register (BDCR)

Notes:

BDCR Controls the amount of time that DMA may remain bus master.

Bits 15 through 8 are used to select a limit for the number of DMA transfers on the Bus while the DMA is bus master. This limit is a binary number, a value of zero disables the transaction limit function.

Bits 7 through 0 are used to select a limit for the number of clock cycles that the DMA may remain on the bus as bus master.

Bus transaction will always complete, even if the clock cycle limit is exceeded during the bus cycle, and even if the cycle is extended by external hardware signalling through /WAIT//RDY.

CONTROL REGISTERS (Continued)

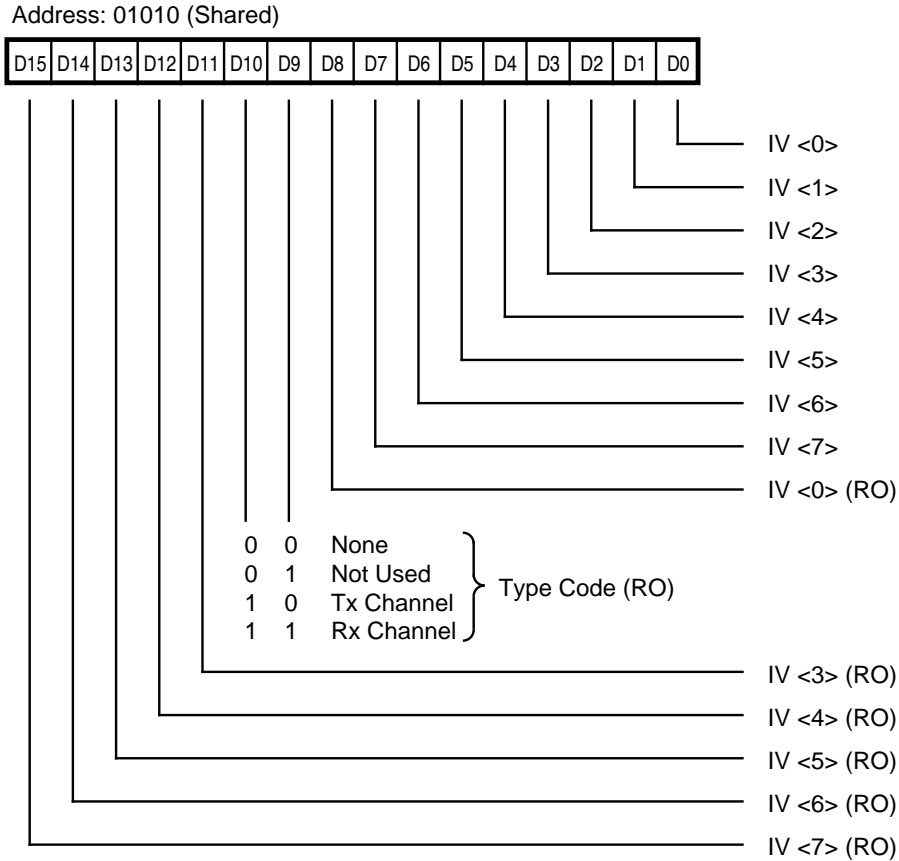

Figure 16. DMA Interrupt Vector Register (DIVR)

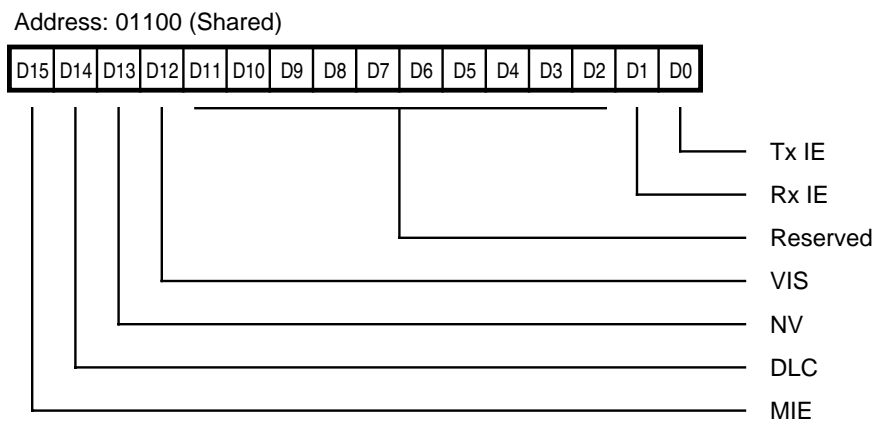

Figure 17. DMA Interrupt Control Register (DICR)

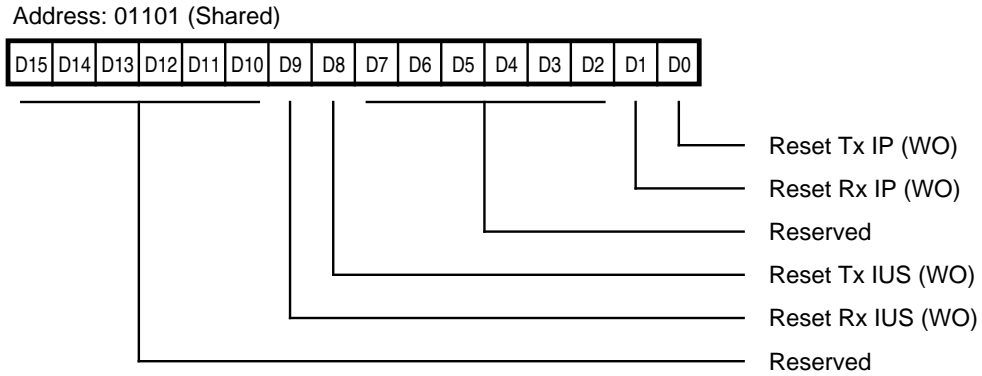

Figure 18. Clear DMA Interrupt Register (CDIR)

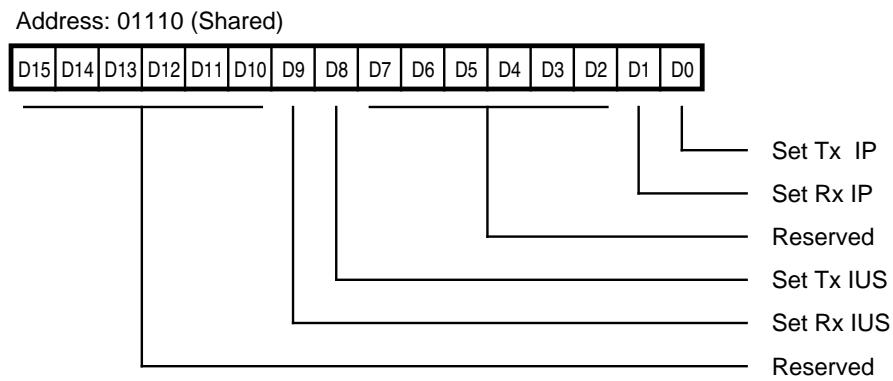

Figure 19. Set DMA Interrupt Register (SDIR)

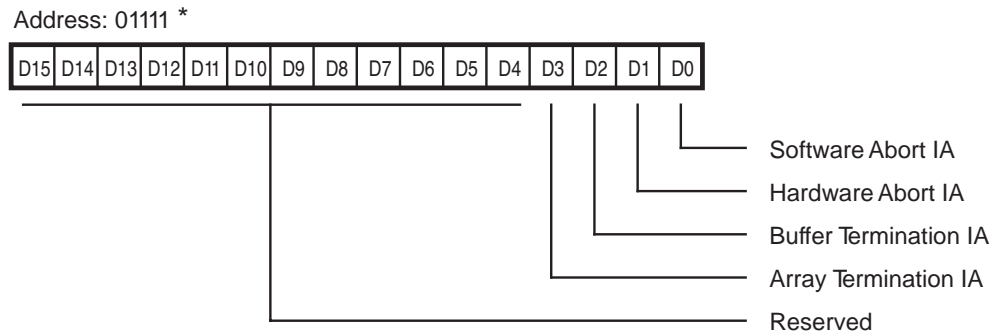

Figure 20. Tx/Rx DMA Interrupt Arm (TDIAR)/(RDIAR)

Notes:

* The format of this register is the same for the receiver and transmitter. The transmit register is accessed by addressing it with the D//C pin Low (0). The receive register is accessed by addressing it with the D//C pin High (1). This applies to Figures 20 through 26.

CONTROL REGISTERS (Continued)

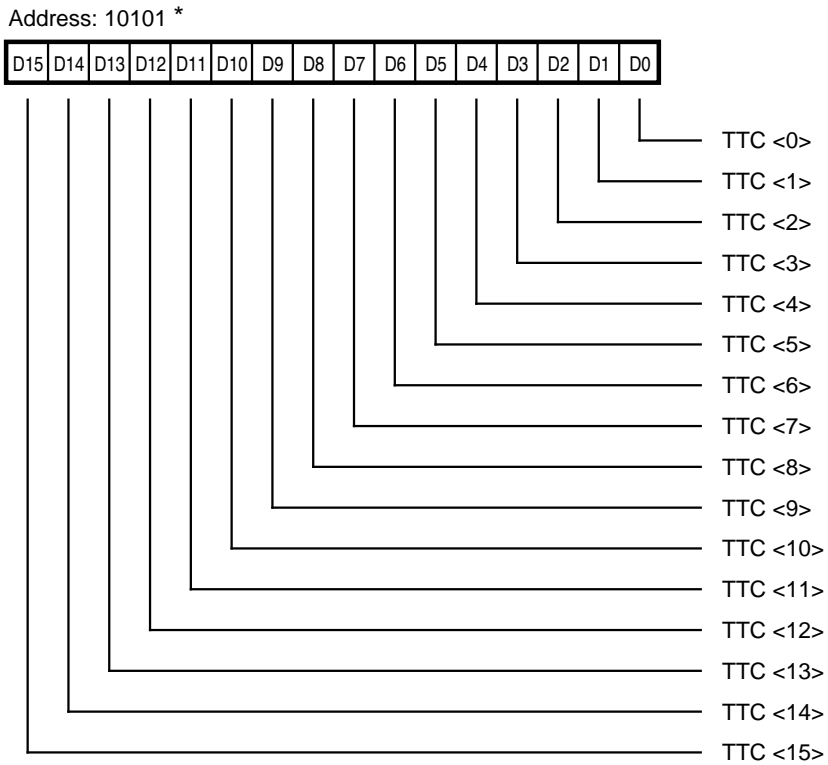

Figure 21. Tx/Rx Byte Count Register (TBCR)/(RBCR)

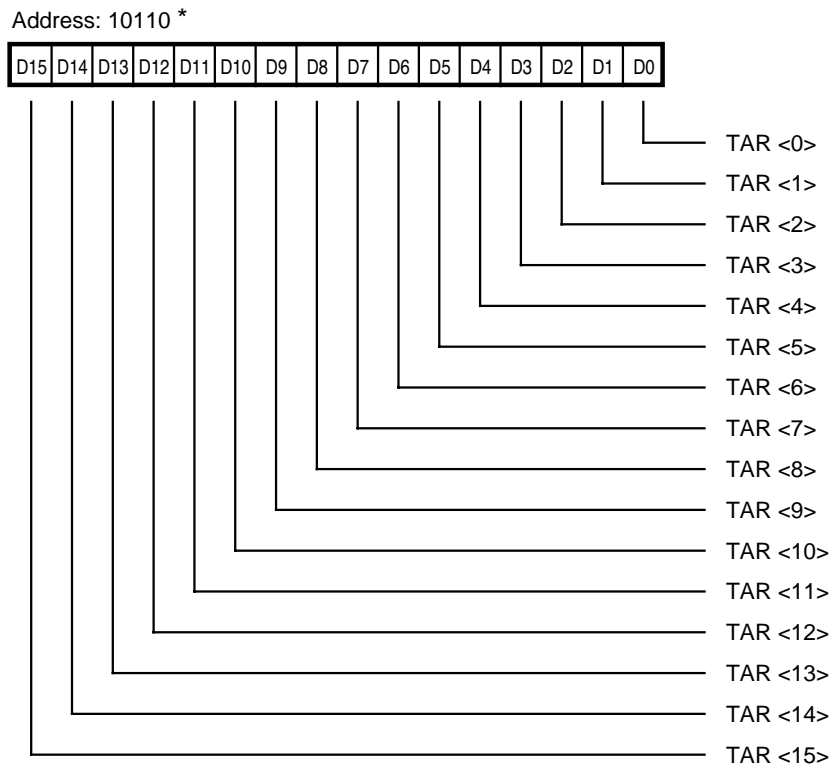

Figure 22. Tx/Rx Address Register (lower) (TARL)/(RARL)

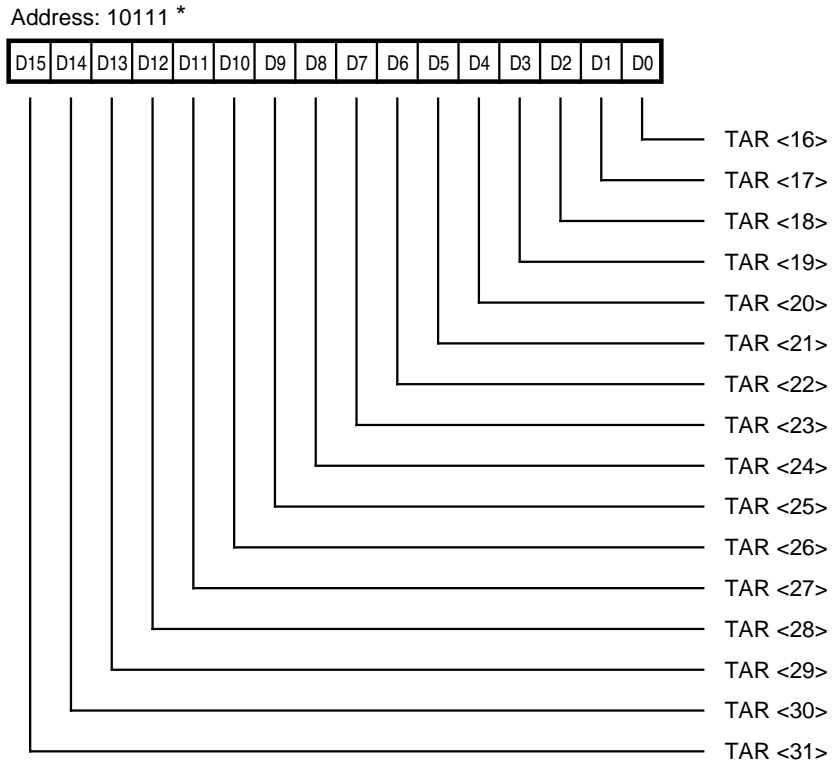

Figure 23. Tx/Rx Address Register (Upper) (TARU)/(RARU)

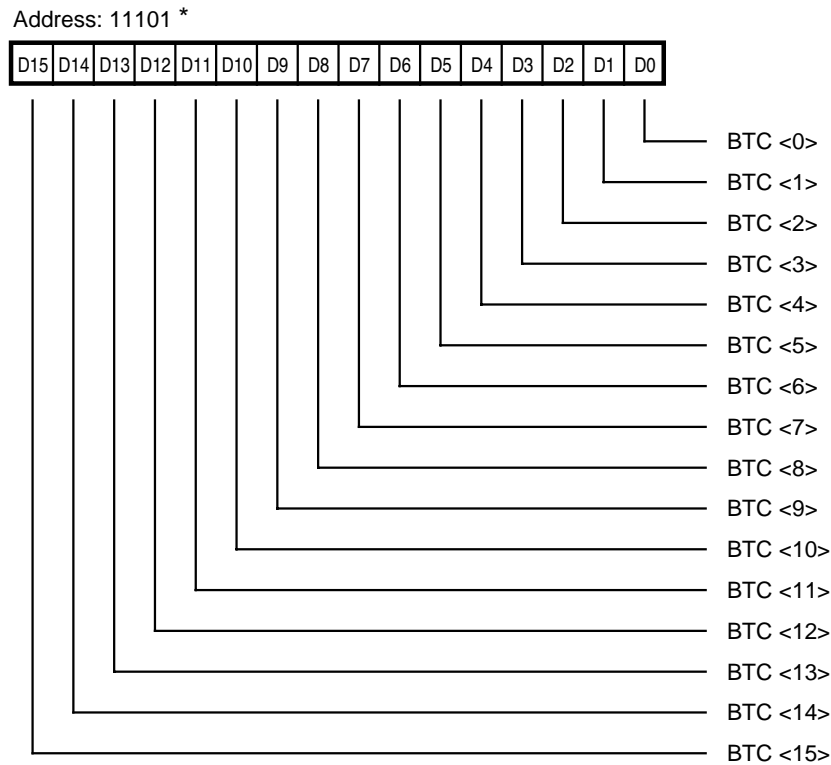

Figure 24. Next Tx/Rx Byte Counter Register (NTBCR)/(RTBCR)

CONTROL REGISTERS (Continued)

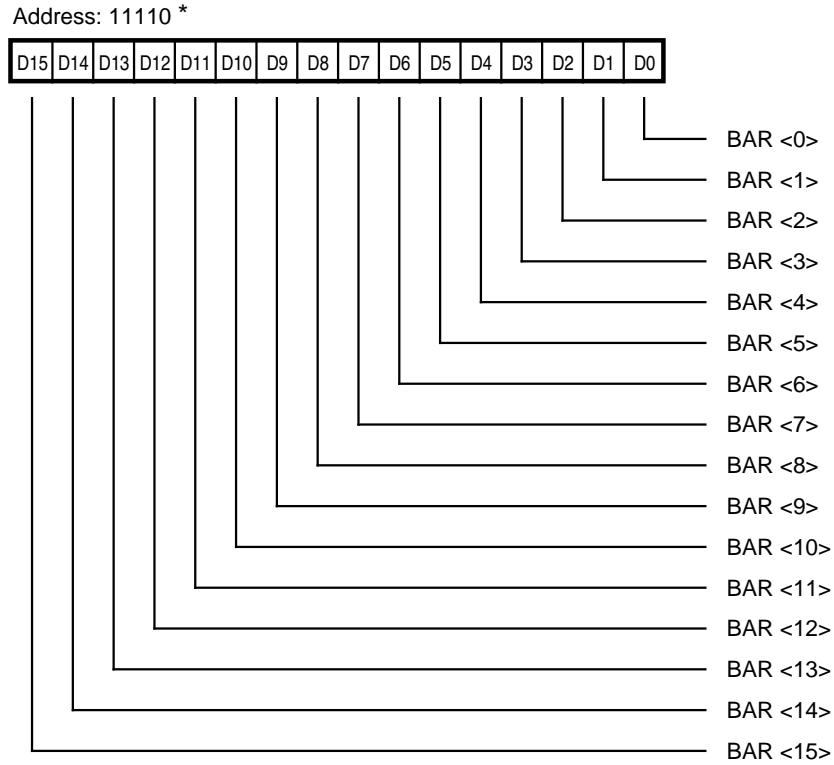

Figure 25. Next Tx/Rx Address Register (Lower) (NTARL)/(RTARL)

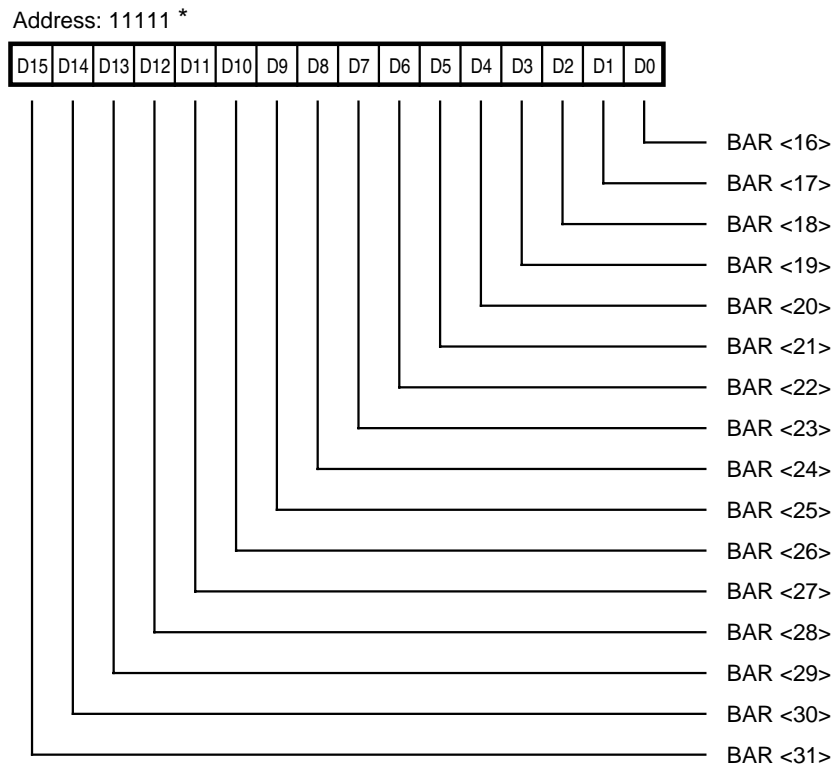

Figure 26. Next Tx/Rx Address Register (Upper) (NTARU)/(RTARU)

		AD15	AD0
Base Address	Buffer #1	AD<31-24>	AD<23-16>
Base Address + 2		AD<15-8>	AD<7-0>
Base Address + 4		CNT<15-8>	CNT<7-0>
Base Address + 6	Buffer #2	AD<31-24>	AD<23-16>
Base Address + 8		AD<15-8>	AD<7-0>
Base Address + 10		CNT<15-8>	CNT<7-0>
Base Address + 12	Buffer #3	AD<31-24>	AD<23-16>
Base Address + 14		AD<15-8>	AD<7-0>
Base Address + 16		CNT<15-8>	CNT<7-0>
Last Base Address	Dummy	Ignored	Ignored
Last Base Address + 2		Ignored	Ignored
Last Base Address + 4		0 0 0 0 0 0 0 0	0 0 0 0 0 0 0 0
Base Address Register After Termination			

Figure 27a. Array-Chained, 16-Bit Bus, Big End Array

Note:

The addition of frame status/control information in the array with Linked Frame Status Transfer Enabled is similar for Big and Little End Array. See Figure 27b.

CONTROL REGISTERS (Continued)

		AD15	AD0
Base Address	Buffer #1	AD<31-24>	AD<23-16>
Base Address + 2		AD<15-8>	AD<7-0>
Base Address + 4		CNT <15-8>	CNT <7-0>
Base Address + 6		RSB/TCB <15-8>	RSB/TCB <7-0>
Base Address + 8		RCHR/TCLR <15-8>	RCHR/TCLR <7-0>
Base Address + 10		0	0
Base Address + 12	Buffer #2	AD<31-24>	AD<23-16>
Base Address + 14		AD<15-8>	AD<7-0>
Base Address + 16		CNT <15-8 >	CNT <7-0>
Base Address + 18		RSB/TCB <15-8>	RSB/TCB <7-0>
Base Address + 20		RCHR/TCLR <15-8>	RCHR/TCLR <7-0>
Base Address + 22		0	0
Base Address + 24	Buffer #3	AD<31-24>	AD<23-16>
Base Address + 26		AD<15-8>	AD<7-0>
Base Address + 28		CNT <15-8>	CNT <7-0>
Base Address + 30		RSB/TCB <15-8>	RSB/TCB <7-0>
Base Address + 32		RCHR/TCLR <15-8>	RCHR/TCLR <7-0>
Base Address + 34		0	0
Last Base Address	Dummy	Ignored	Ignored
Last Base Address + 2		Ignored	Ignored
Last Base Address + 4		0 0 0 0 0 0 0 0	0 0 0 0 0 0 0 0
Base Address Register After Termination			

**Figure 27b. Array-Chained, 16-Bit Bus, Big End Array
Linked Frame Status Transfer Enabled**

		AD15	AD0
Base Address	Buffer #1	AD<15-8>	AD<7-0>
Base Address + 2		AD<31-24>	AD<23-16>
Base Address + 4		CNT<15-8>	CNT<7-0>
Base Address + 6	Buffer #2	AD<15-8>	AD<7-0>
Base Address + 8		AD<31-24>	AD<23-16>
Base Address + 10		CNT<15-8>	CNT<7-0>
Base Address + 12	Buffer #3	AD<15-8>	AD<7-0>
Base Address + 14		AD<31-24>	AD<23-16>
Base Address + 16		CNT<15-8>	CNT<7-0>
Last Base Address	Dummy	Ignored	Ignored
Last Base Address + 2		Ignored	Ignored
Last Base Address + 4		0 0 0 0 0 0 0 0	0 0 0 0 0 0 0 0
Base Address Register After Termination			

Figure 28. Array-Chained, 16-Bit Bus, Little End Array

CONTROL REGISTERS (Continued)

		AD7	AD0
Base Address	Buffer #1	AD<31-24>	
Base Address + 1		AD<23-16>	
Base Address + 2		AD<15-8>	
Base Address + 3		AD<7-0>	
Base Address + 4		CNT<15-8>	
Base Address + 5	CNT<7-0>		
Base Address + 6	Buffer #2	AD<31-24>	
Base Address + 7		AD<23-16>	
Base Address + 8		AD<15-8>	
Base Address + 9		AD<7-0>	
Base Address + 10		CNT<15-8>	
Base Address + 11		CNT<7-0>	
Last Base Address	Dummy	Ignored	
Last Base Address + 1		Ignored	
Last Base Address + 2		Ignored	
Last Base Address + 3		Ignored	
Last Base Address + 4		0 0 0 0 0 0 0 0	
Last Base Address + 5		0 0 0 0 0 0 0 0	
Base Address Register After Termination			

Figure 29a. Array-Chained, 8-Bit Bus, Big End Array**Note:**

The addition of frame status/control information in the array with Linked Frame Status Transfer Enabled is similar for Big and Little End Array. See Figure 29b.

		AD7	AD0
Base Address	Buffer #1	AD<31-24>	
Base Address + 1		AD<23-16>	
Base Address + 2		AD<15-8>	
Base Address + 3		AD<7-0>	
Base Address + 4		CNT<15-8>	
Base Address + 5		CNT<7-0>	
Base Address + 6		RSB/TCB <15-8>	
Base Address + 7		RSB/TCB <7-0>	
Base Address + 8		RCHR/TCLR <15-8>	
Base Address + 9		RSHR/TCLR <7-0>	
Base Address + 10		0	
Base Address + 11	0		
Base Address + 12	Buffer #2	AD<31-24>	
Base Address + 13		AD<23-16>	
Base Address + 14		AD<15-8>	
Base Address + 15		AD<7-0>	
Base Address + 16		CNT<15-8>	
Base Address + 17		CNT<7-0>	
Base Address + 18		RSB/TCB <15-8>	
Base Address + 19		RSB/TCB <7-0>	
Base Address + 20		RCHR/TCLR <15-8>	
Base Address + 21		RSHR/TCLR <7-0>	
Base Address + 22		0	
Base Address + 23	0		
Last Base Address	Dummy	Ignored	
Last Base Address + 1		Ignored	
Last Base Address + 2		Ignored	
Last Base Address + 3		Ignored	
Last Base Address + 4		0 0 0 0 0 0 0 0	
Last Base Address + 5		0 0 0 0 0 0 0 0	
Base Address Register After Termination			

Figure 29b. Array-Chained, 8-Bit Bus, Big End Array, Linked Frame Status Transfer Enabled

CONTROL REGISTERS (Continued)

		AD7	AD0
Base Address	Buffer #1	AD<7-0>	
Base Address + 1		AD<15-8>	
Base Address + 2		AD<23-16>	
Base Address + 3		AD<31-24>	
Base Address + 4		CNT<7-0>	
Base Address + 5	Buffer #2	CNT<15-8>	
Base Address + 6		AD<7-0>	
Base Address + 7		AD<15-8>	
Base Address + 8		AD<23-16>	
Base Address + 9		AD<31-24>	
Base Address + 10		CNT<7-0>	
Base Address + 11		CNT<15-8>	
Last Base Address	Dummy	Ignored	
Last Base Address + 1		Ignored	
Last Base Address + 2		Ignored	
Last Base Address + 3		Ignored	
Last Base Address + 4		0 0 0 0 0 0 0 0	
Last Base Address + 5		0 0 0 0 0 0 0 0	
Base Address Register After Termination			

Figure 30. Array-Chained, 8-Bit Bus, Little End Array

		AD15	AD0
Base Address	Buffer #1	AD<31-24>	AD<23-16>
Base Address + 2		AD<15-8>	AD<7-0>
Base Address + 4		CNT<15-8>	CNT<7-0>
Base Address + 6	Base #2	AD<31-24>	AD<23-16>
Base Address + 8		AD<15-8>	AD<7-0>
#2 Base Address	Buffer #2	AD<31-24>	AD<23-16>
#2 Base Address + 2		AD<15-8>	AD<7-0>
#2 Base Address + 4		CNT<15-8>	CNT<7-0>
#2 Base Address + 6	Base #3	AD<31-24>	AD<23-16>
#2 Base Address + 8		AD<15-8>	AD<7-0>
#3 Base Address	Buffer #3	AD<31-24>	AD<23-16>
#3 Base Address + 2		AD<15-8>	AD<7-0>
#3 Base Address + 4		CNT<15-8>	CNT<7-0>
#n - 1 Base Address + 6	Base #n	AD<31-24>	AD<23-16>
#n - 1 Base Address + 8		AD<15-8>	AD<7-0>
#n Base Address	Buffer #n	Ignored	Ignored
#n Base Address + 2		Ignored	Ignored
#n Base Address + 4		0 0 0 0 0 0 0 0	0 0 0 0 0 0 0 0

Figure 31a. Linked Array-Chained, 16-Bit Bus, Big End Array

Note:

The addition of frame status/control information in the array with Linked Frame Status Transfer Enabled is similar for Big and Little End Array. See Figure 31b.

CONTROL REGISTERS (Continued)

		AD15	AD0
Base Address	Buffer #1	AD<31-24>	AD<23-16>
Base Address + 2		AD <15-8>	AD<7-0>
Base Address + 4		CNT<15-8>	CNT<7-0>
Base Address + 6		RSB/TCB <15-8>	RSB/TCB <7-0>
Base Address + 8		RCHR/TCLR <15-8>	RCHR/TCLR <7-0>
Base Address + 10		0	0
Base Address + 12	Base #2	AD<31-24>	AD<23-16>
Base Address + 14		AD <15-8>	AD<7-0>
#2 Base Address	Buffer #2	AD<31-24>	AD<23-16>
#2 Base Address + 2		AD <15-8>	AD<7-0>
#2 Base Address + 4		CNT<15-8>	CNT<7-0>
#2 Base Address + 6		RSB/TCB <15-8>	RSB/TCB <7-0>
#2 Base Address + 8		RCHR/TCLR <15-8>	RCHR/TCLR <7-0>
#2 Base Address + 10		0	0
#2 Base Address + 12	Base #3	AD<31-24>	AD<23-16>
#2 Base Address + 14		AD <15-8>	AD<7-0>
#3 Base Address	Buffer #3	AD<31-24>	AD<23-16>
#3 Base Address + 2		AD <15-8>	AD<7-0>
#3 Base Address + 4		CNT<15-8>	CNT<7-0>
#3 Base Address + 6		RSB/TCB <15-8>	RSB/TCB <7-0>
#3 Base Address + 8		RCHR/TCLR <15-8>	RCHR/TCLR <7-0>
#3 Base Address + 10		0	0

Figure 31b. Linked Array-Chained, 16-Bit Bus, Big End Array

		AD15	AD0
Base Address	Buffer #1	AD<15-8>	AD<7-0>
Base Address + 2		AD<31-24>	AD<23-16>
Base Address + 4		CNT<15-8>	CNT<7-0>
Base Address + 6	Base #2	AD<15-8>	AD<7-0>
Base Address + 8		AD<31-24>	AD<23-16>
#2 Base Address	Buffer #2	AD<15-8>	AD<7-0>
#2 Base Address + 2		AD<31-24>	AD<23-16>
#2 Base Address + 4		CNT<15-8>	CNT<7-0>
#2 Base Address + 6	Base #3	AD<15-8>	AD<7-0>
#2 Base Address + 8		AD<31-24>	AD<23-16>
#3 Base Address	Buffer #3	AD<15-8>	AD<7-0>
#3 Base Address + 2		AD<31-24>	AD<23-16>
#3 Base Address + 4		CNT<15-8>	CNT<7-0>
#n - 1 Base Address + 6	Base #n	AD<15-8>	AD<7-0>
#n - 1 Base Address + 8		AD<31-24>	AD<23-16>
#n Base Address	Buffer #n	Ignored	Ignored
#n Base Address + 2		Ignored	Ignored
#n Base Address + 4		0 0 0 0 0 0 0	0 0 0 0 0 0 0

Figure 32. Linked Array-Chained, 16-Bit Bus, Little End Array

CONTROL REGISTERS (Continued)

		AD7	AD0
Base Address	Buffer #1	AD<7-0>	
Base Address + 1		AD<15-8>	
Base Address + 2		AD<23-16>	
Base Address + 3		AD<31-24>	
Base Address + 4		CNT<7-0>	
Base Address + 5		CNT<15-8>	
Base Address + 6	Base #2	AD<7-0>	
Base Address + 7		AD<15-8>	
Base Address + 8		AD<23-16>	
Base Address + 9		AD<31-24>	
#2 Base Address	Buffer #2	AD<7-0>	
#2 Base Address + 1		AD<15-8>	
#2 Base Address + 2		AD<23-16>	
#2 Base Address + 3		AD<31-24>	
#2 Base Address + 4		CNT<7-0>	
#2 Base Address + 5		CNT<15-8>	
#2 Base Address + 6	Base #3	AD<7-0>	
#2 Base Address + 7		AD<15-8>	
#2 Base Address + 8		AD<23-16>	
#2 Base Address + 9		AD<31-24>	

Figure 33a. Linked Array-Chained, 8-Bit Bus, Big End Array

Note:

The addition of frame status/control information in the array with Linked Frame Status Transfer Enabled is similar to Big End Array. See Figure 33b.

		AD7	AD0
Base Address	Buffer #1	AD<31-24>	
Base Address + 1		AD<23-16>	
Base Address + 2		AD<15-8>	
Base Address + 3		AD<7-0>	
Base Address + 4		CNT<15-8>	
Base Address + 5		CNT<7-0>	
Base Address + 6		RSB/TCB <15-8>	
Base Address + 7		RSB/TCB <7-0>	
Base Address + 8		RCHR/TCLR <15-8>	
Base Address + 9		RCHR/TCLR <7-0>	
Base Address + 10		0	
Base Address + 11		0	
Base Address + 12	Base #2	AD<31-24>	
Base Address + 13		AD<23-16>	
Base Address + 14		AD<15-8>	
Base Address + 15		AD<7-0>	
#2 Base Address	Buffer #2	AD<31-24>	
#2 Base Address + 1		AD<23-16>	
#2 Base Address + 2		AD<15-8>	
#2 Base Address + 3		AD<7-0>	
#2 Base Address + 4		CNT<15-8>	
#2 Base Address + 5		CNT<7-0>	
#2 Base Address + 6		RSB/TCB <15-8>	
#2 Base Address + 7		RSB/TCB <7-0>	
#2 Base Address + 8		RCHR/TCLR <15-8>	
#2 Base Address + 9		RCHR/TCLR <7-0>	
#2 Base Address + 10		0	
#2 Base Address + 11		0	

Figure 33b. Linked Frame Status Transfer Enables

CONTROL REGISTERS (Continued)

		AD7	AD0
Base Address	Buffer #1	AD<31-24>	
Base Address + 1		AD<23-16>	
Base Address + 2		AD<15-8>	
Base Address + 3		AD<7-0>	
Base Address + 4		CNT<15-8>	
Base Address + 5		CNT<7-0>	
Base Address + 6	Base #2	AD<31-24>	
Base Address + 7		AD<23-16>	
Base Address + 8		AD<15-8>	
Base Address + 9		AD<7-0>	
#2 Base Address	Buffer #2	AD<31-24>	
#2 Base Address + 1		AD<23-16>	
#2 Base Address + 2		AD<15-8>	
#2 Base Address + 3		AD<7-0>	
#2 Base Address + 4		CNT<15-8>	
#2 Base Address + 5		CNT<7-0>	
#2 Base Address + 6	Base #3	AD<31-24>	
#2 Base Address + 7		AD<23-16>	
#2 Base Address + 8		AD<15-8>	
#2 Base Address + 9		AD<7-0>	

Figure 34. Linked Array-Chained 8-Bit Bus, Little End Array

CONTROL REGISTERS (Continued)

Address: 00001

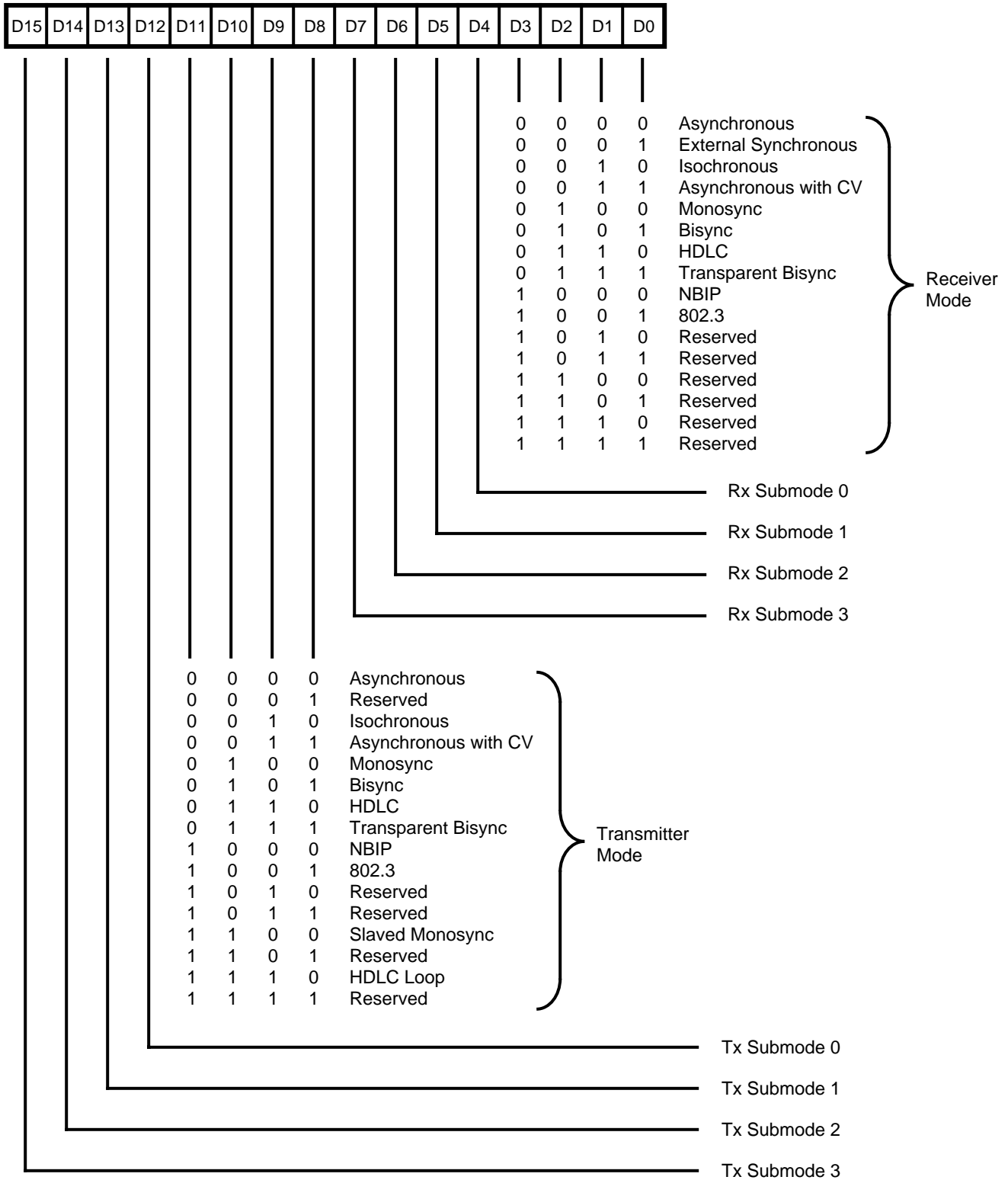

Figure 36. Channel Mode Register (CMR)

Address: 00001

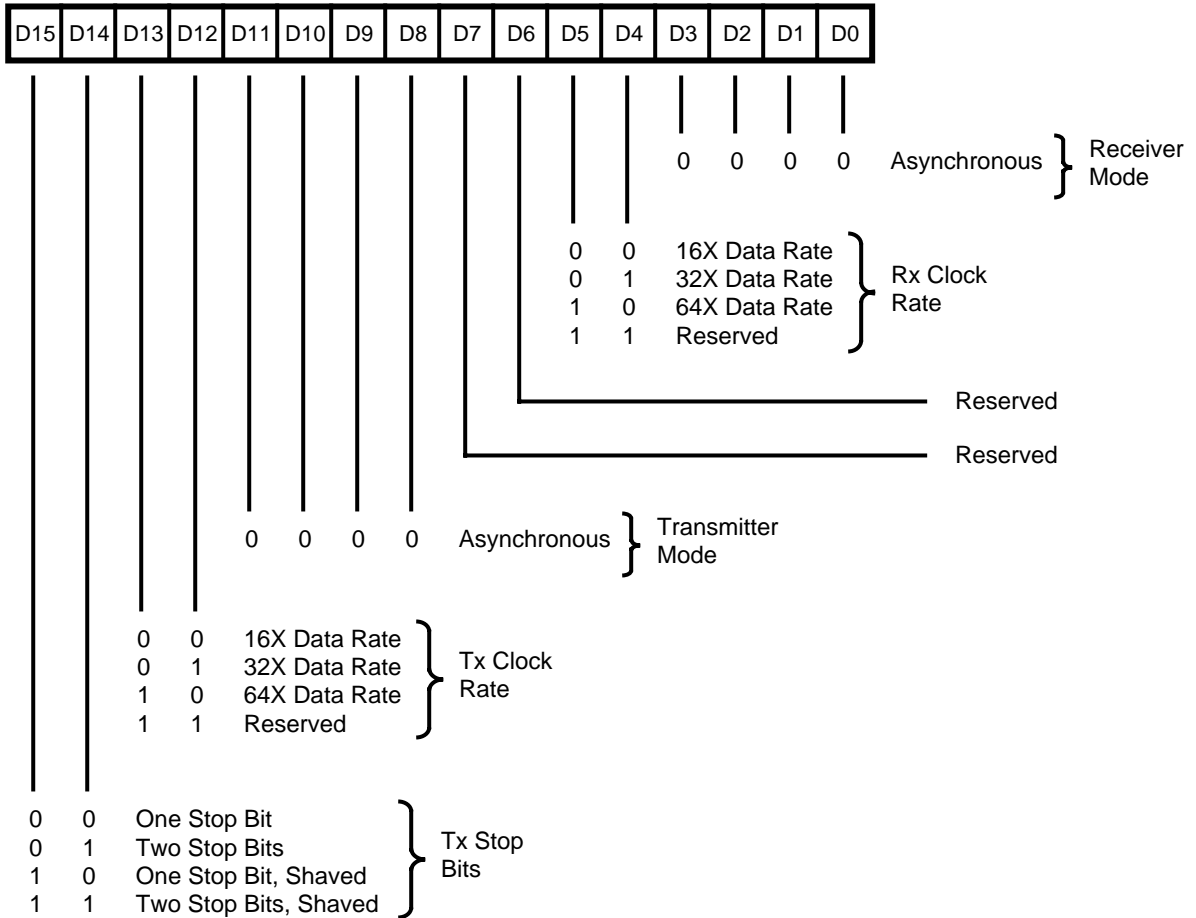

Figure 37. Channel Mode Register, Asynchronous Mode

Address: 00001

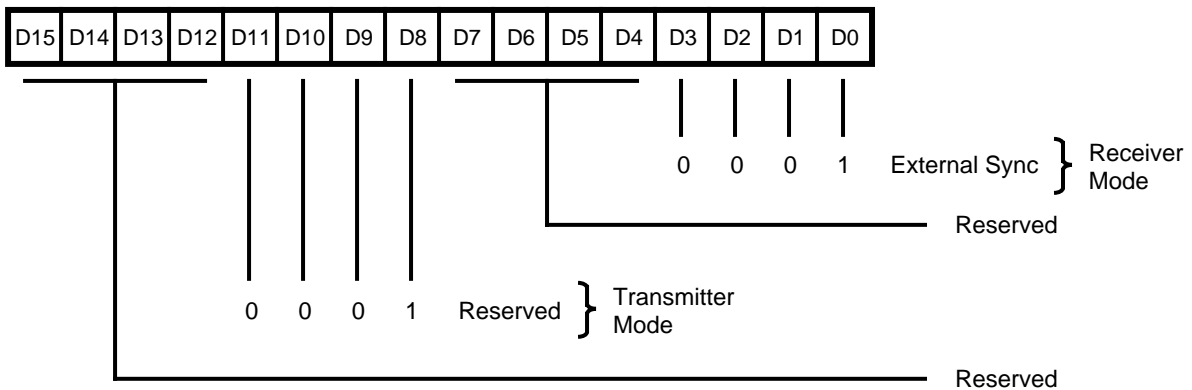

Figure 38. Channel Mode Register, External Sync Mode

CONTROL REGISTERS (Continued)

Address: 00001

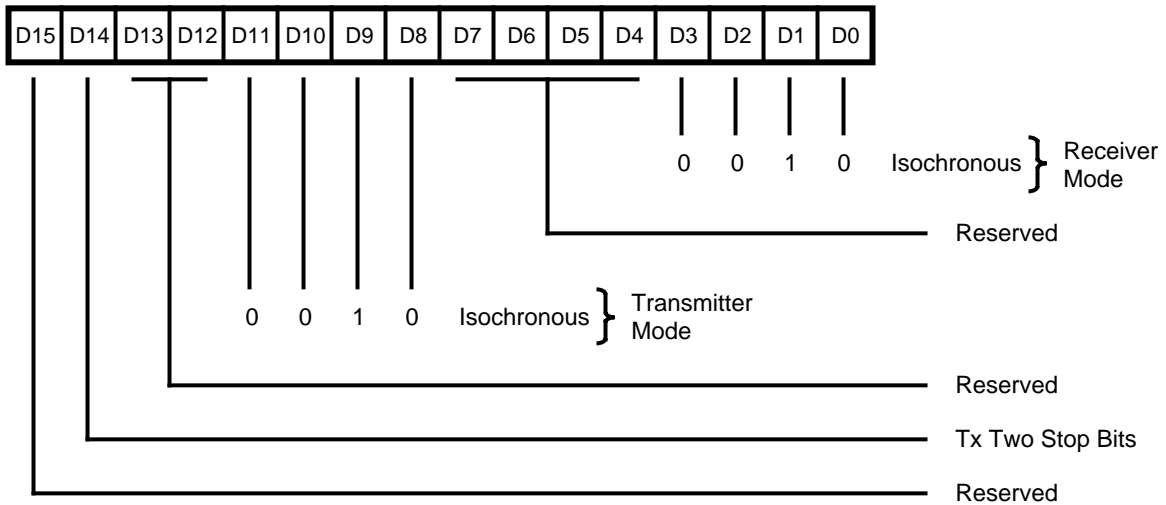

Figure 39. Channel Mode Register, Isochronous Mode

Address: 00001

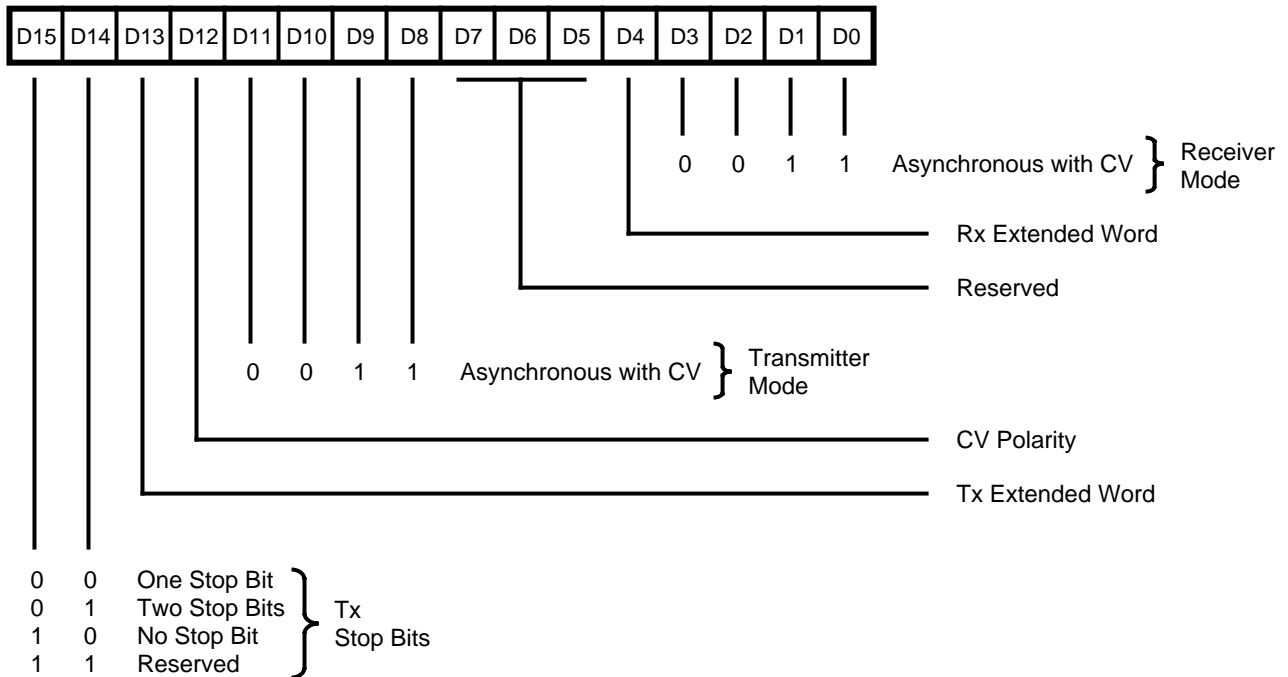

Figure 40. Channel Mode Register, Asynchronous Mode with Code Violation (MIL STD 1553)

Address: 00001

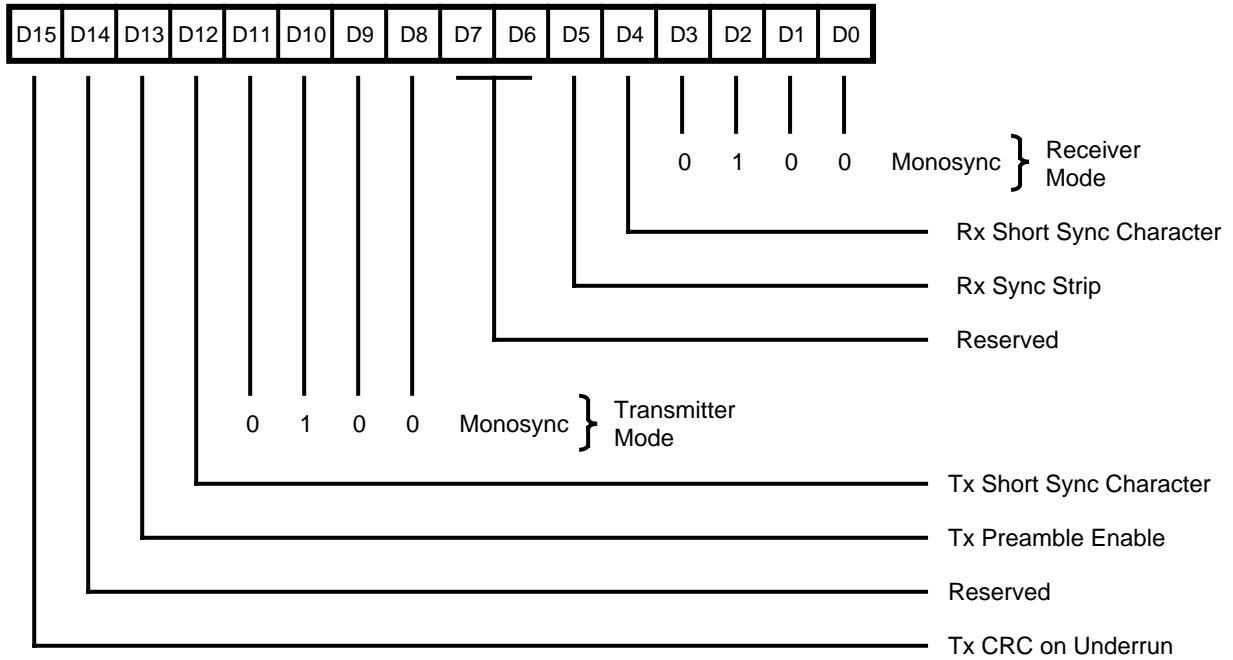

Figure 41. Channel Mode Register, Monosync Mode

Address: 00001

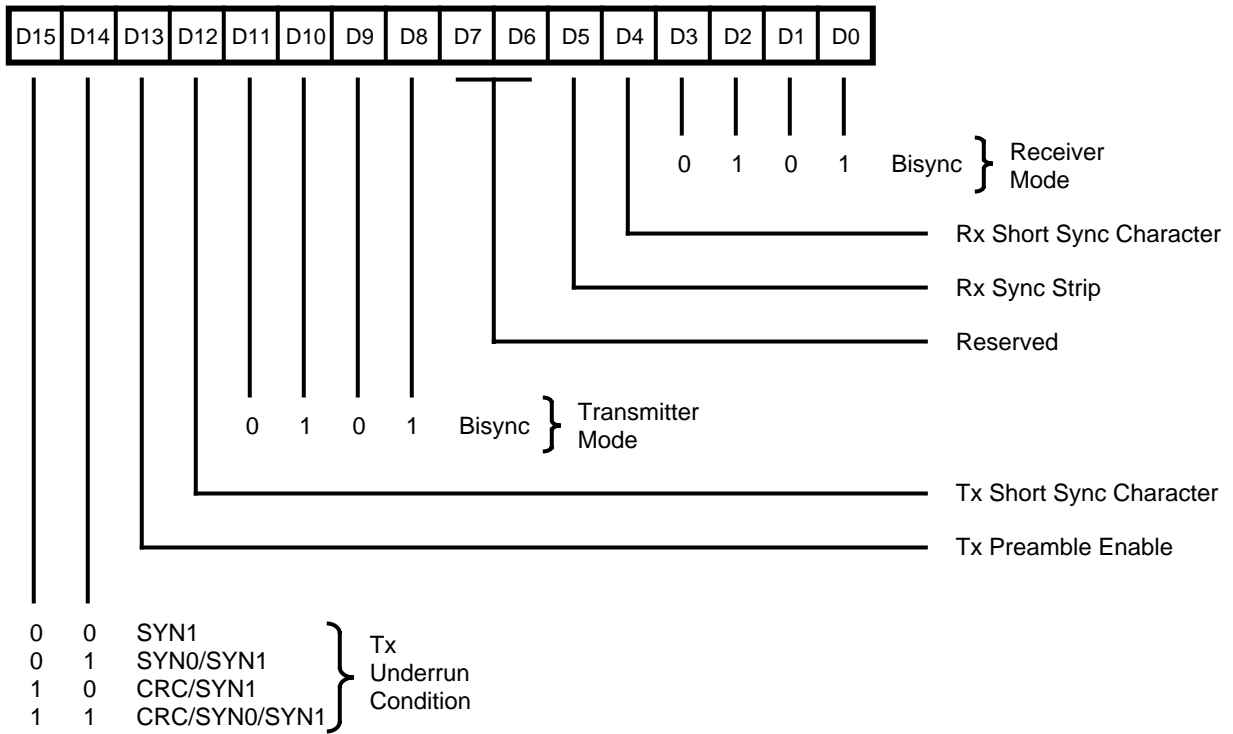

Figure 42. Channel Mode Register, Bisync Mode

CONTROL REGISTERS (Continued)

Address: 00001

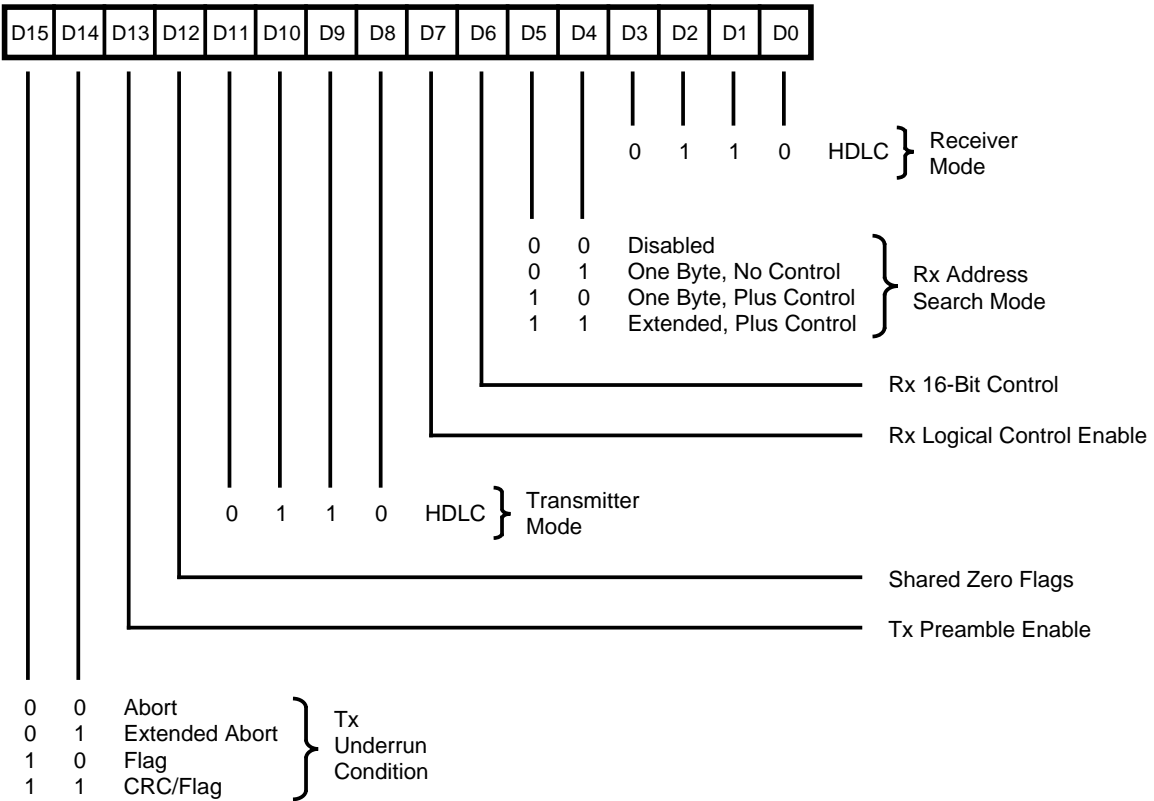

Figure 43. Channel Mode Register, HDLC Mode

Address: 00001

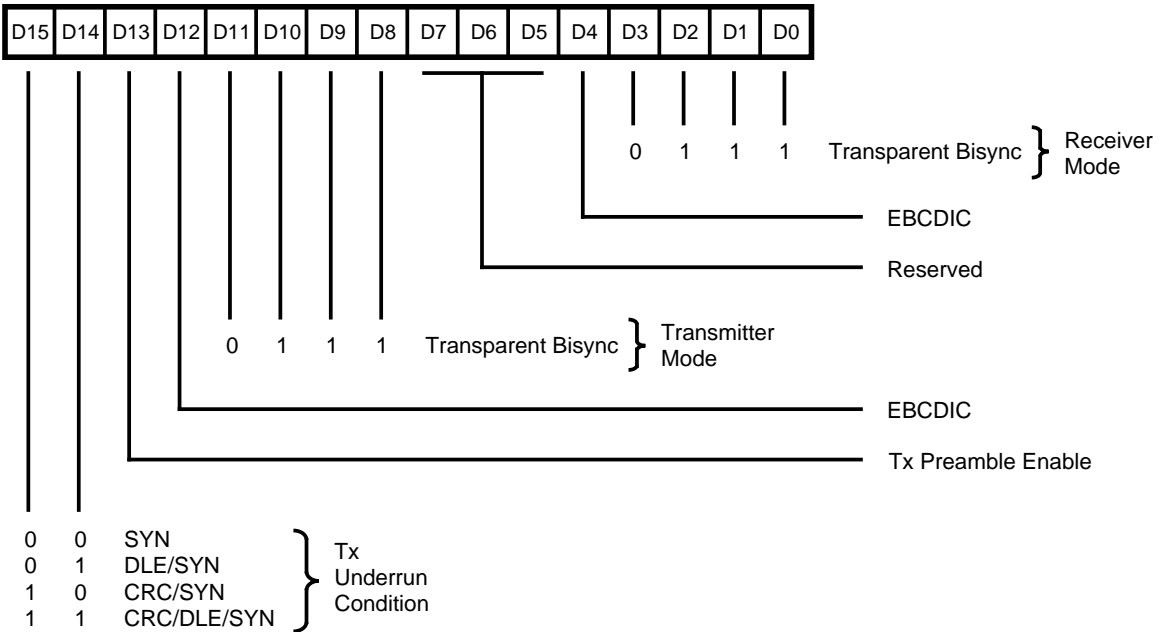

Figure 44. Channel Mode Register, Transparent Bisync Mode

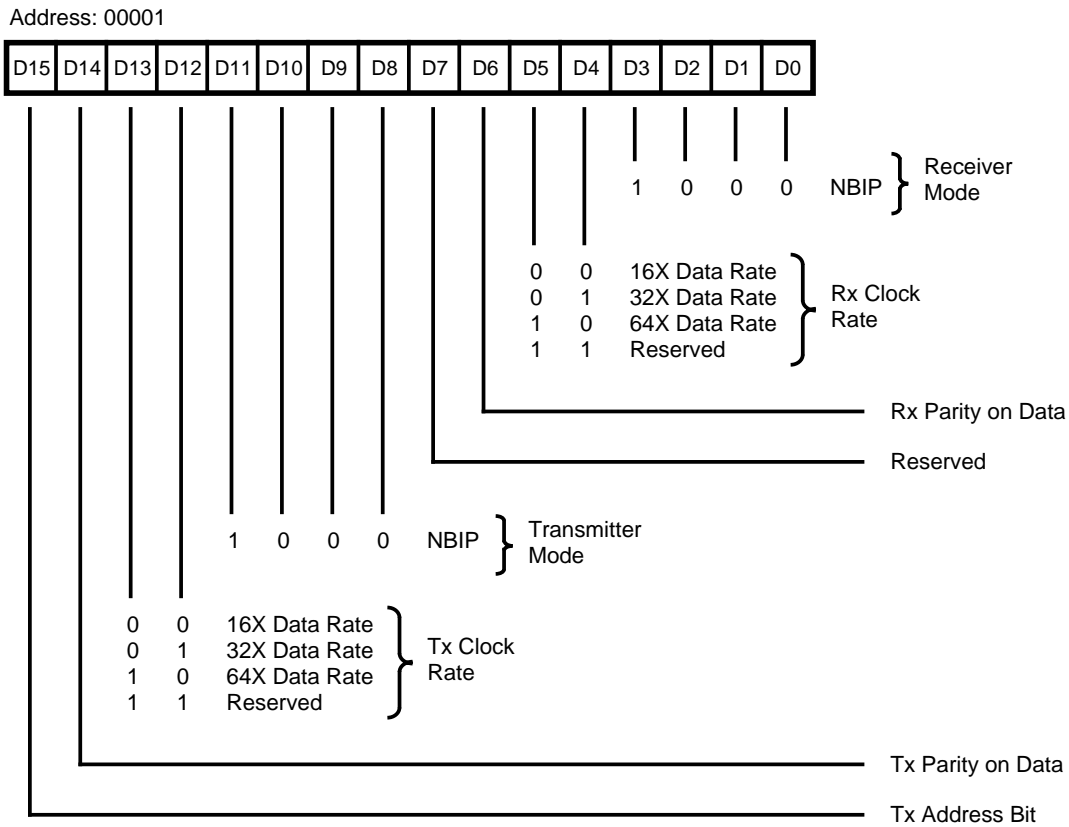

Figure 45. Channel Mode Register, NBIP Mode

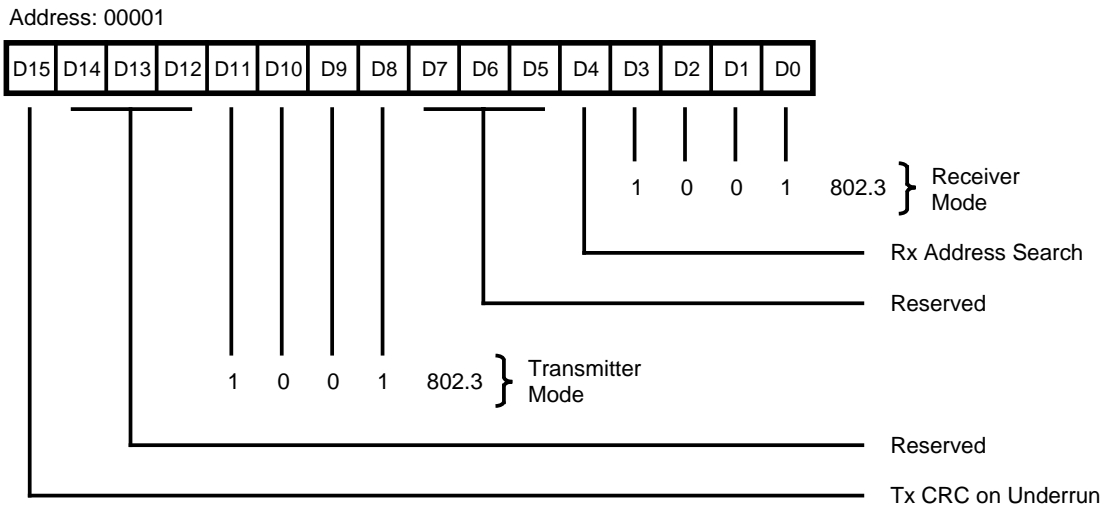

Figure 46. Channel Mode Register, 802.3 Mode

CONTROL REGISTERS (Continued)

Address: 00001

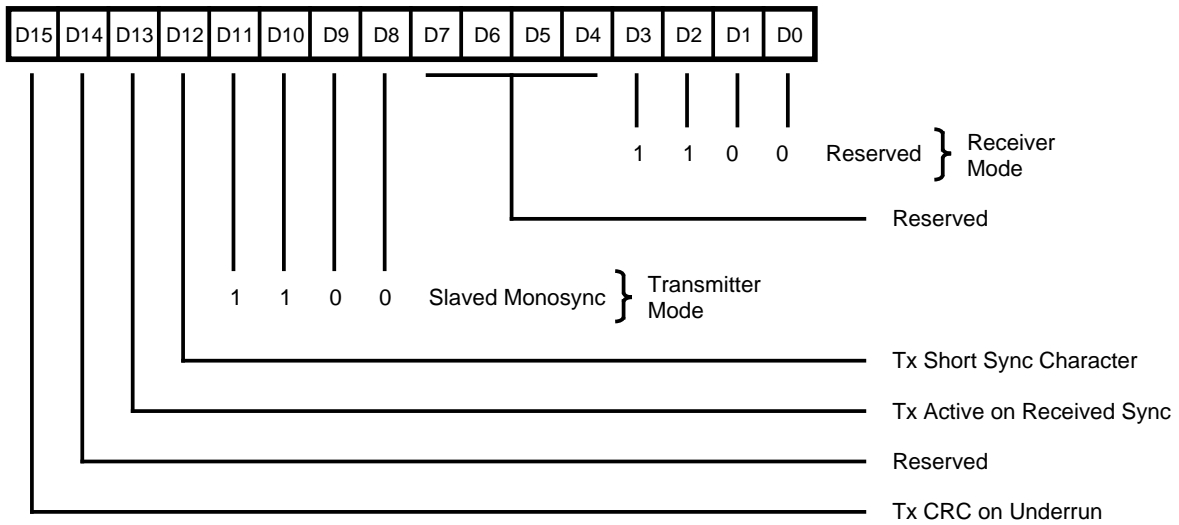

Figure 47. Channel Mode Register, Slaved Monosync Mode

Address: 00001

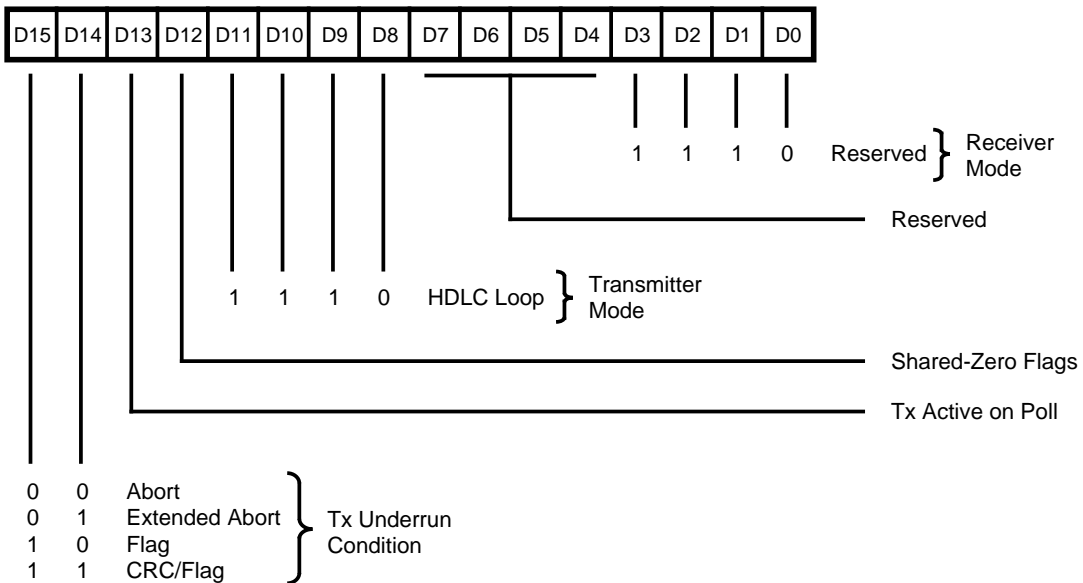

Figure 48. Channel Mode Register, HDLC Loop Mode

Address: 00010

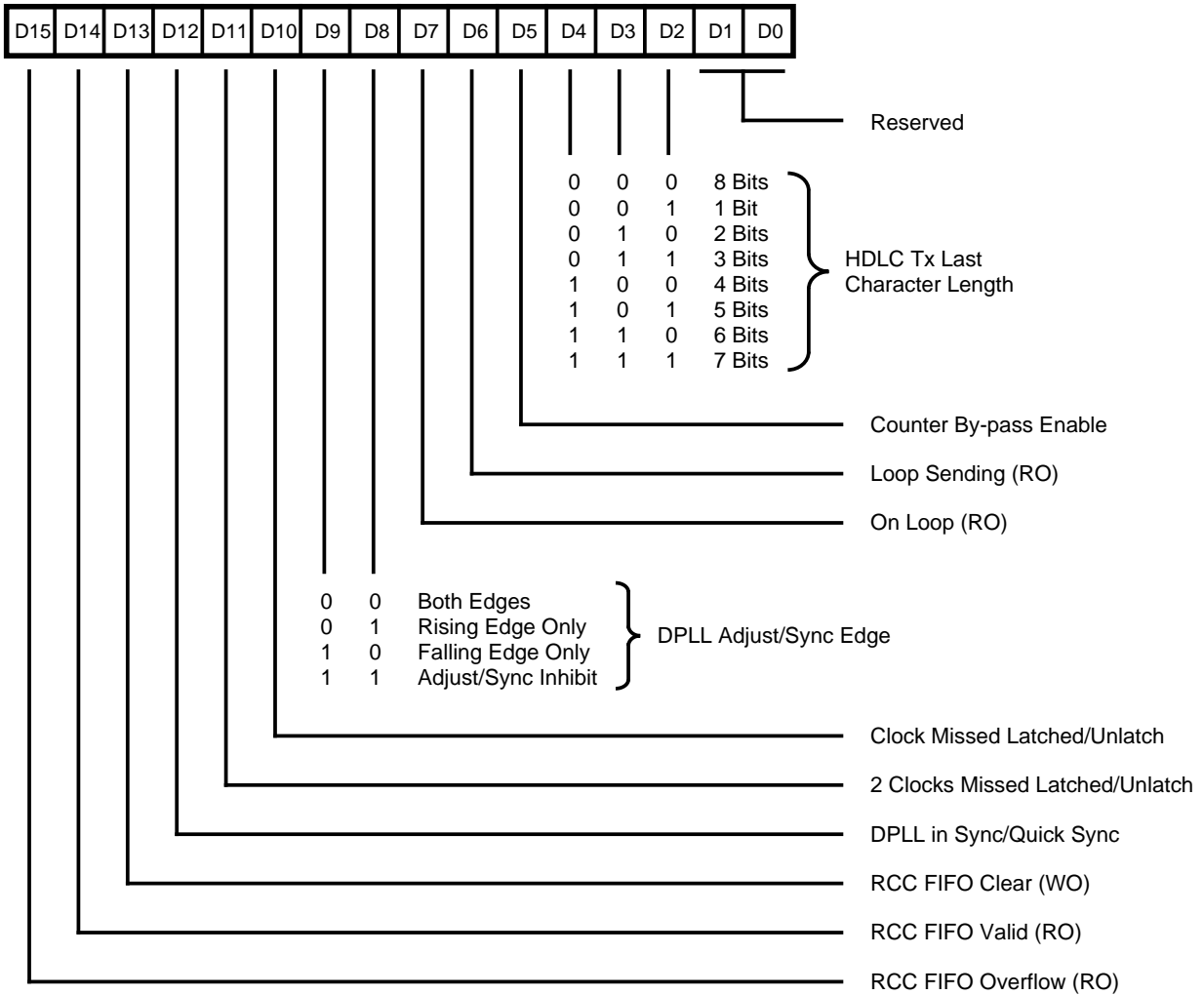

Figure 49. Channel Command/Status Register (CCSR)

CONTROL REGISTERS (Continued)

Address: 00011

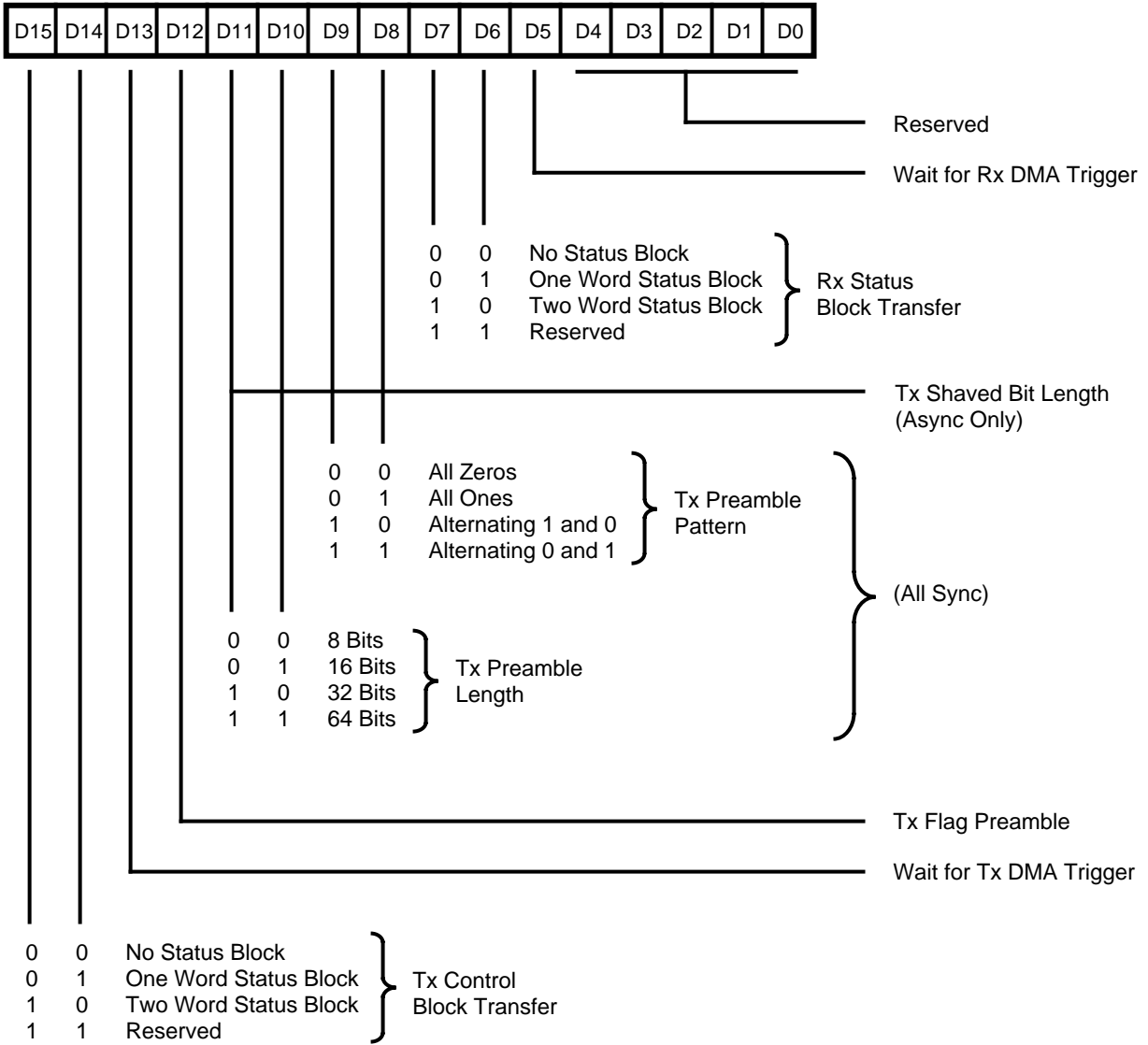

Figure 50. Channel Control Register (CCR)

Address: 00100

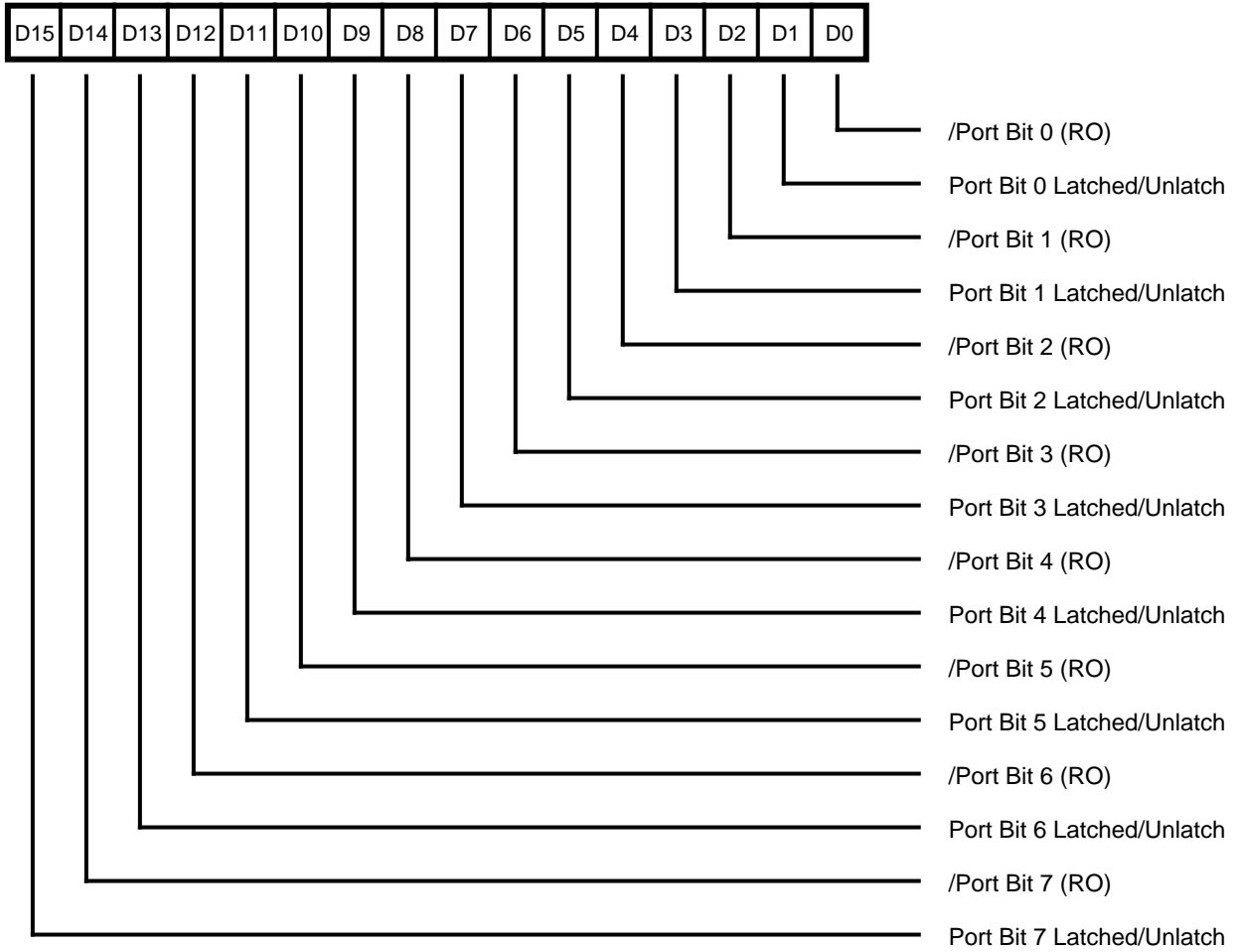

Figure 51. Port Status Register (PSR)

CONTROL REGISTERS (Continued)

Address: 00101

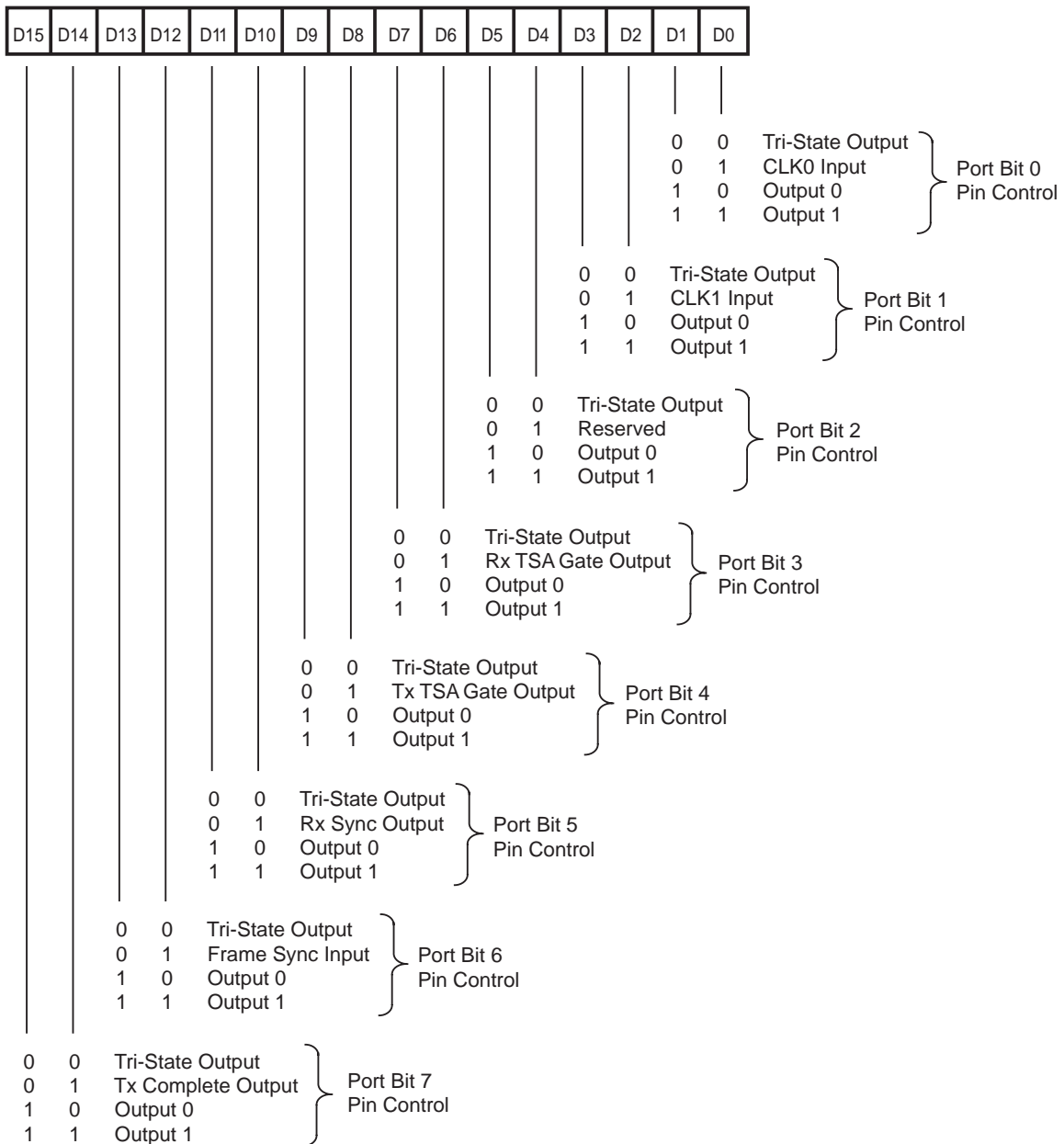

Figure 52. Port Control Register (PCR)

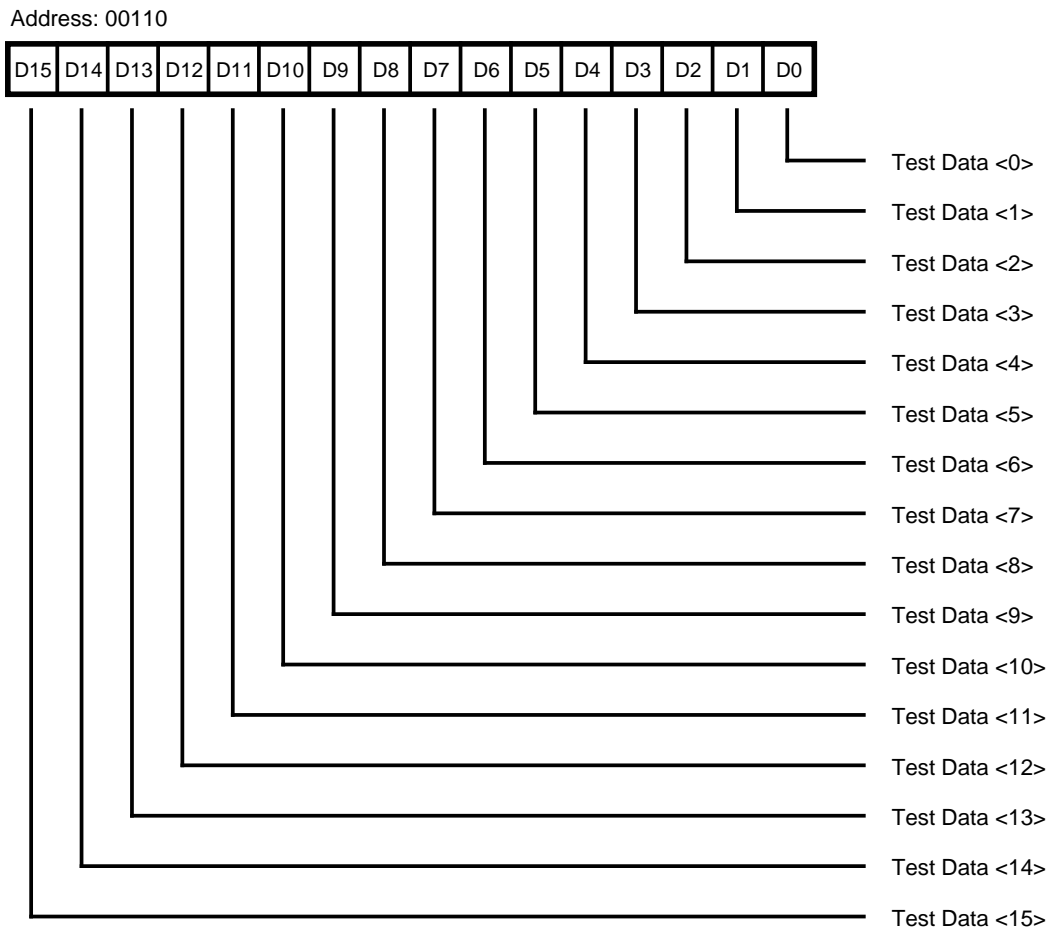

Figure 53. Test Mode Data Register (TMDR)

CONTROL REGISTERS (Continued)

Address: 00111

D15	D14	D13	D12	D11	D10	D9	D8	D7	D6	D5	D4	D3	D2	D1	D0	
											0	0	0	0	0	Null Address
											0	0	0	0	1	High Byte of Shifters
											0	0	0	1	0	CRC Byte 0
											0	0	0	1	1	CRC Byte 1
											0	0	1	0	0	Rx FIFO (Write)
											0	0	1	0	1	Clock Multiplexer Outputs
											0	0	1	1	0	CTR0 and CTR1 Counters
											0	0	1	1	1	Clock Multiplexer Inputs
											0	1	0	0	0	DPLL State
											0	1	0	0	1	Low Byte of Shifters
											0	1	0	1	0	CRC Byte 2
											0	1	0	1	1	CRC Byte 3
											0	1	1	0	0	Tx FIFO (Read)
											0	1	1	0	1	Reserved
											0	1	1	1	0	I/O and Device Status Latches
											0	1	1	1	1	Internal Daisy Chain
											1	0	0	0	0	Reserved
											1	0	0	0	1	Reserved
											1	0	0	1	0	Reserved
											1	0	0	1	1	Reserved
											1	0	1	0	0	Reserved
											1	0	1	0	1	Reserved
											1	0	1	1	0	Rx Count Holding Register
											1	0	1	1	1	Reserved
											1	1	0	0	0	Reserved
											1	1	0	0	1	Reserved
											1	1	0	1	0	Reserved
											1	1	0	1	1	4453H
											1	1	1	0	0	Reserved
											1	1	1	0	1	Reserved
											1	1	1	1	0	Reserved
											1	1	1	1	1	4453H
																Reserved

Figure 54. Test Mode Control Register (TMCR)

Note:

When software writes the value 1F to the LS byte of the Test Mode Control Register (TMCR), and then reads the Test Mode Data Register (TMDR), current versions of the Z16C32 will return hex 4453. Future revisions, if any, will return other values.

Address: 01000

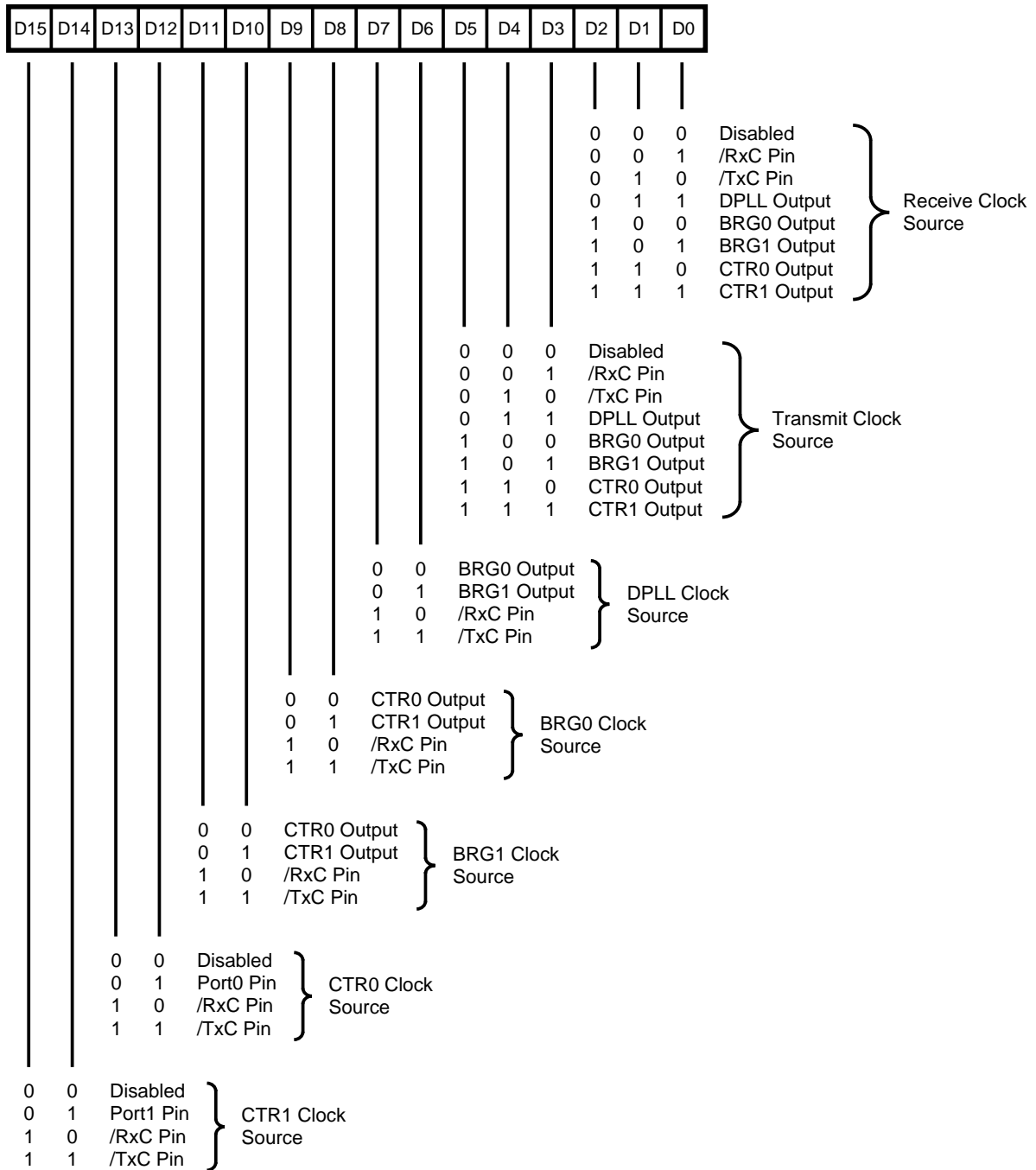

Figure 55. Clock Mode Control Register (CMCR)

CONTROL REGISTERS (Continued)

Address: 01001

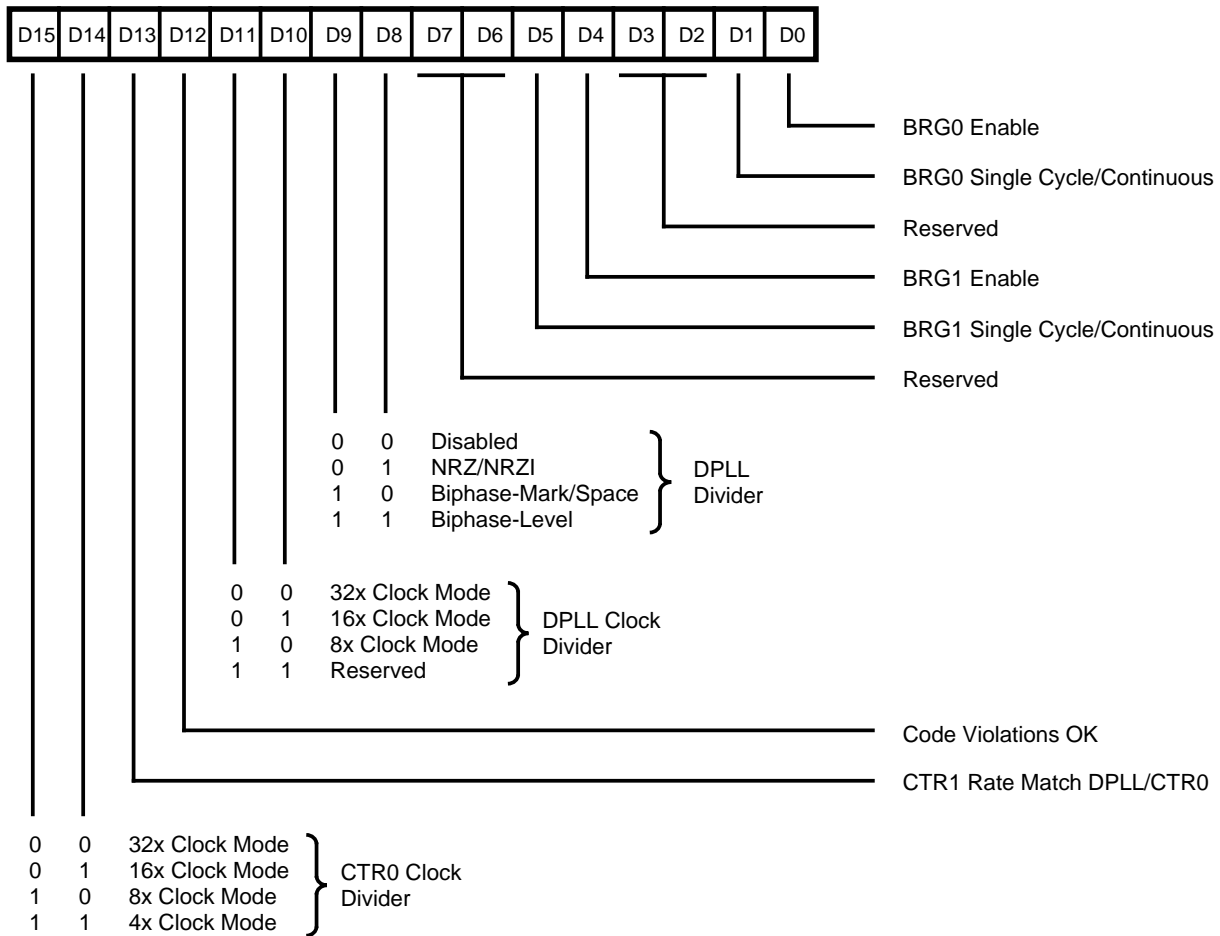

Figure 56. Hardware Configuration Register (HCR)

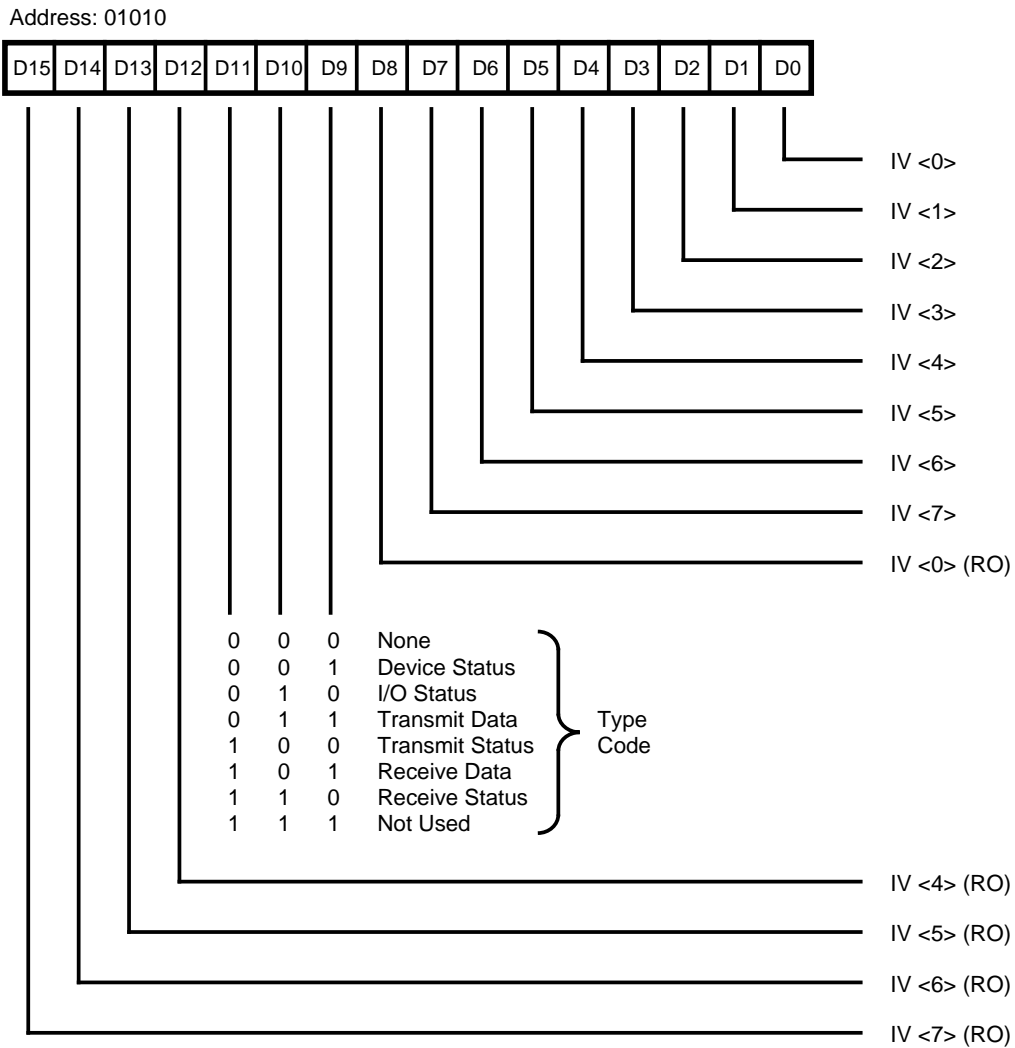

Figure 57. Interrupt Vector Register (IVR)

CONTROL REGISTERS (Continued)

Address: 01011

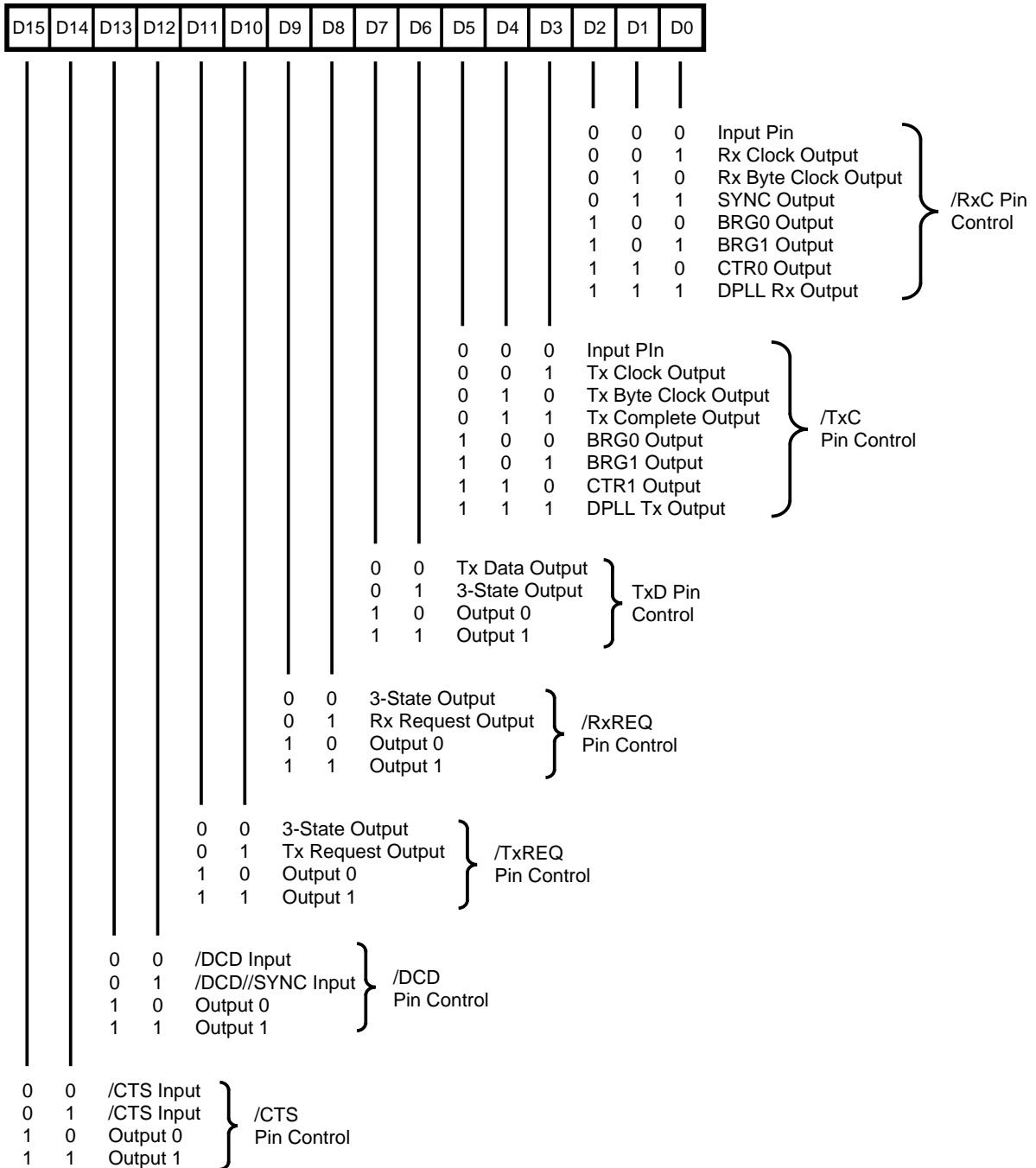

Figure 58. I/O Control Register (IOCR)

Address: 01100

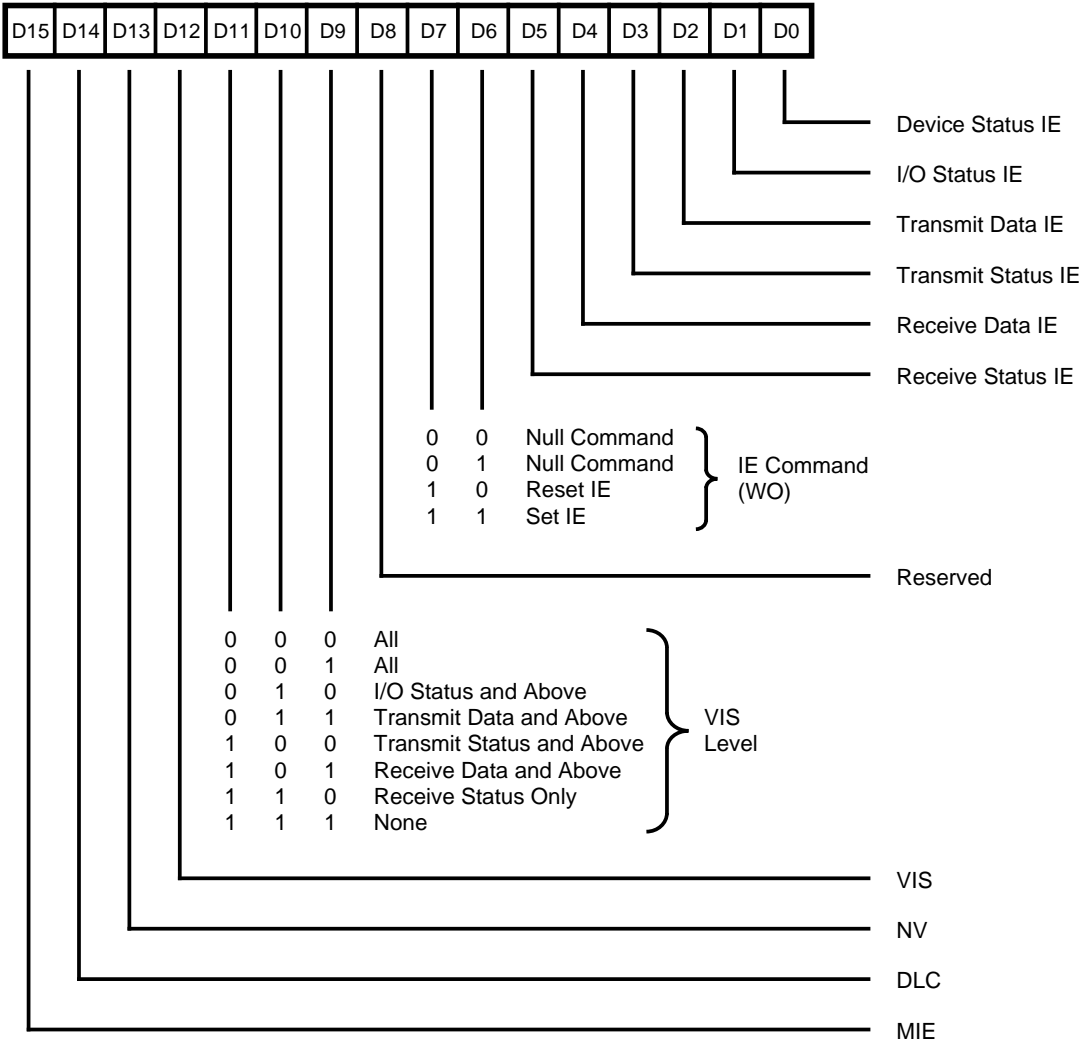

Figure 59. Interrupt Control Register (ICR)

CONTROL REGISTERS (Continued)

Address: 01101

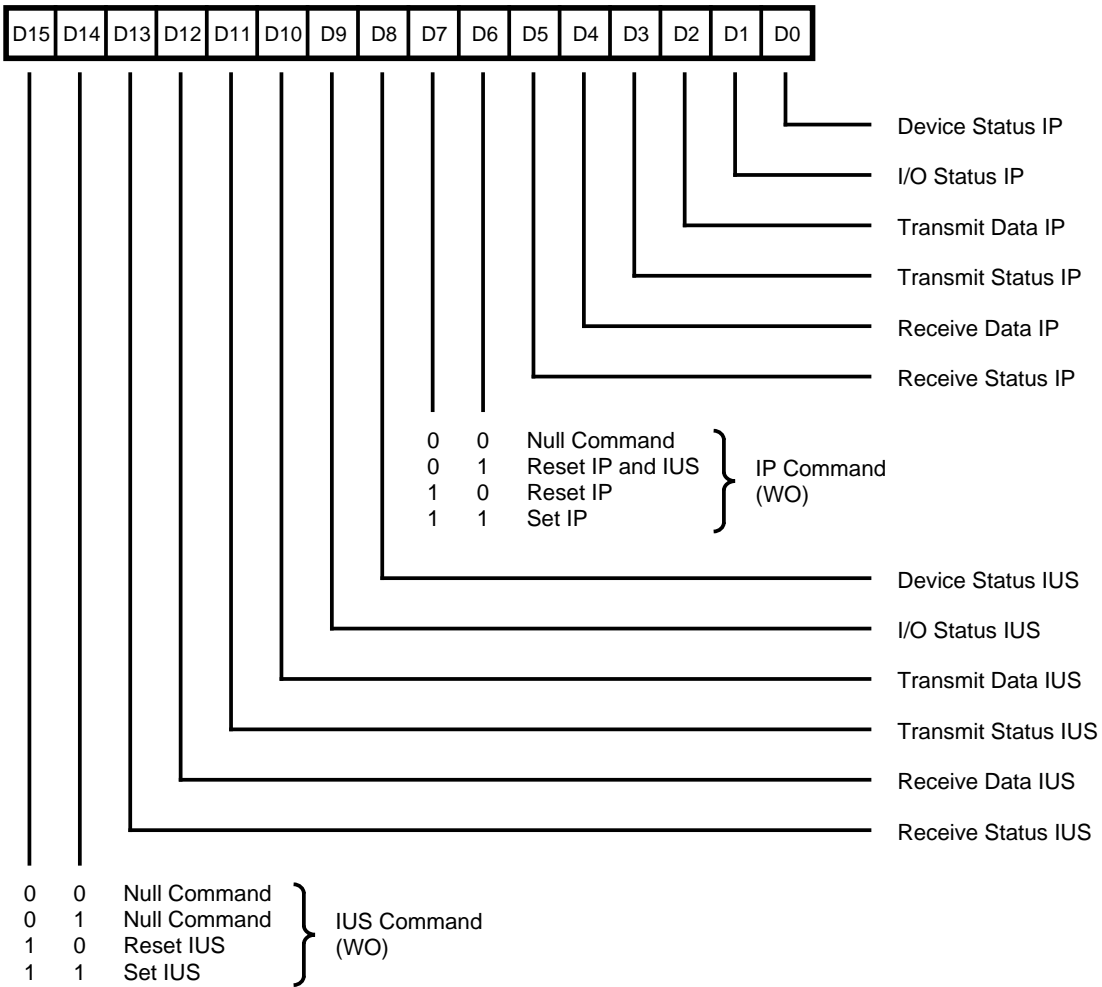

Figure 60. Daisy-Chain Control Register (DCCR)

Address: 01110

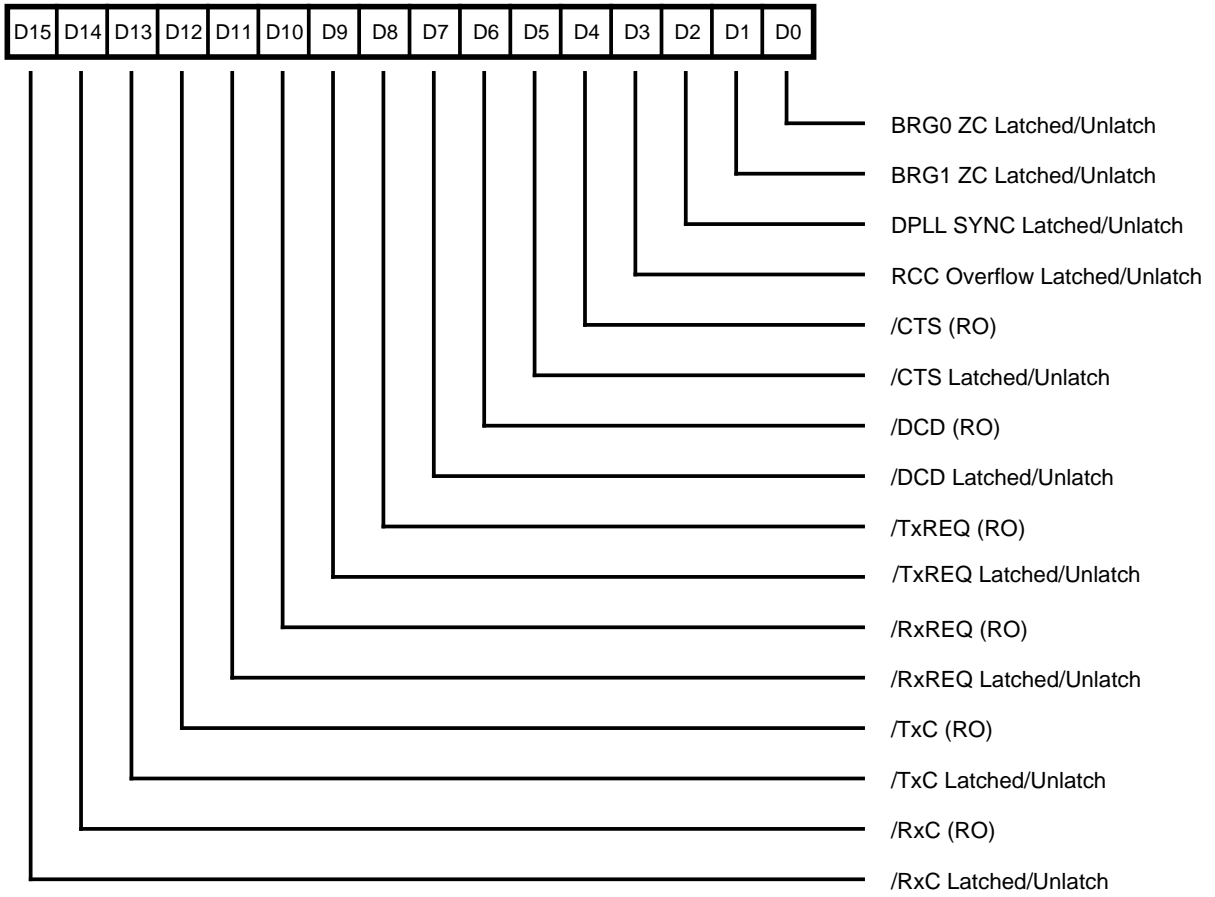

Figure 61. Miscellaneous Interrupt Status Register (MISR)

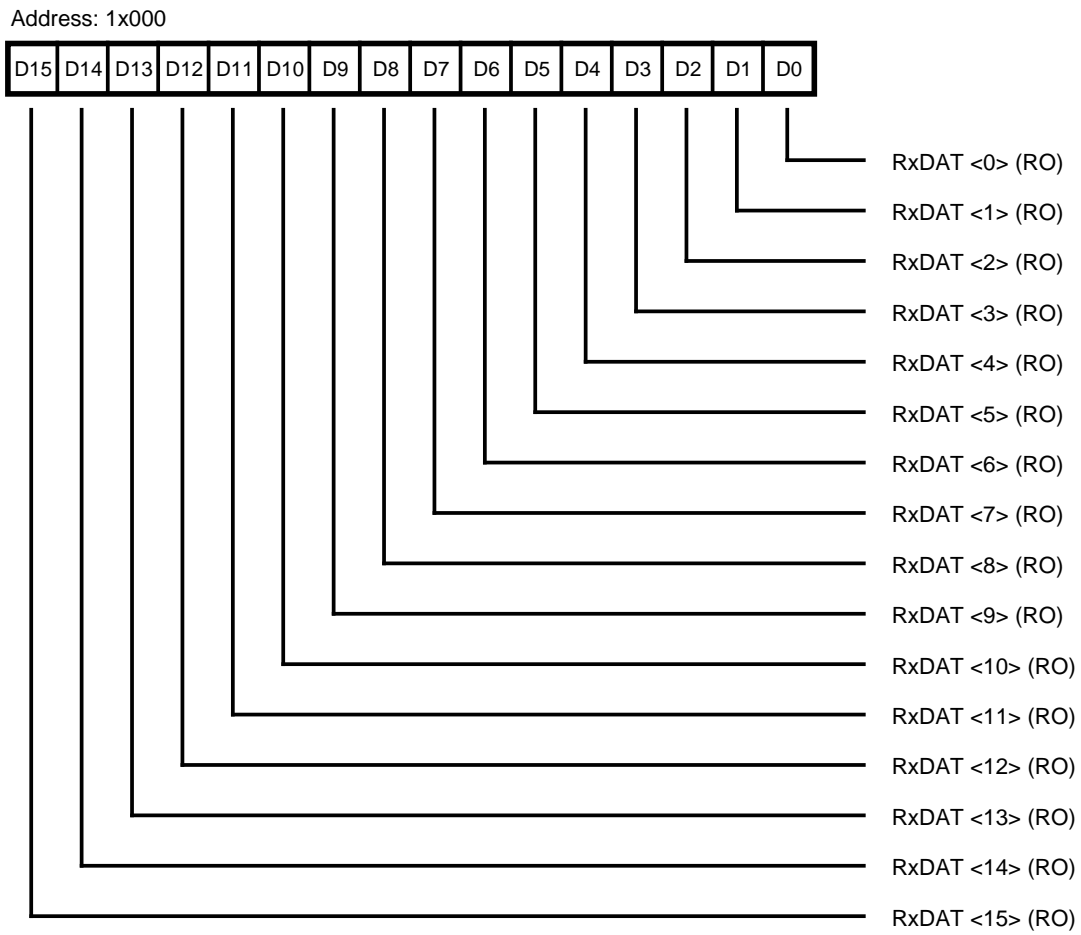

Figure 63. Receive Data Register (RDR)

CONTROL REGISTERS (Continued)

Address: 10001

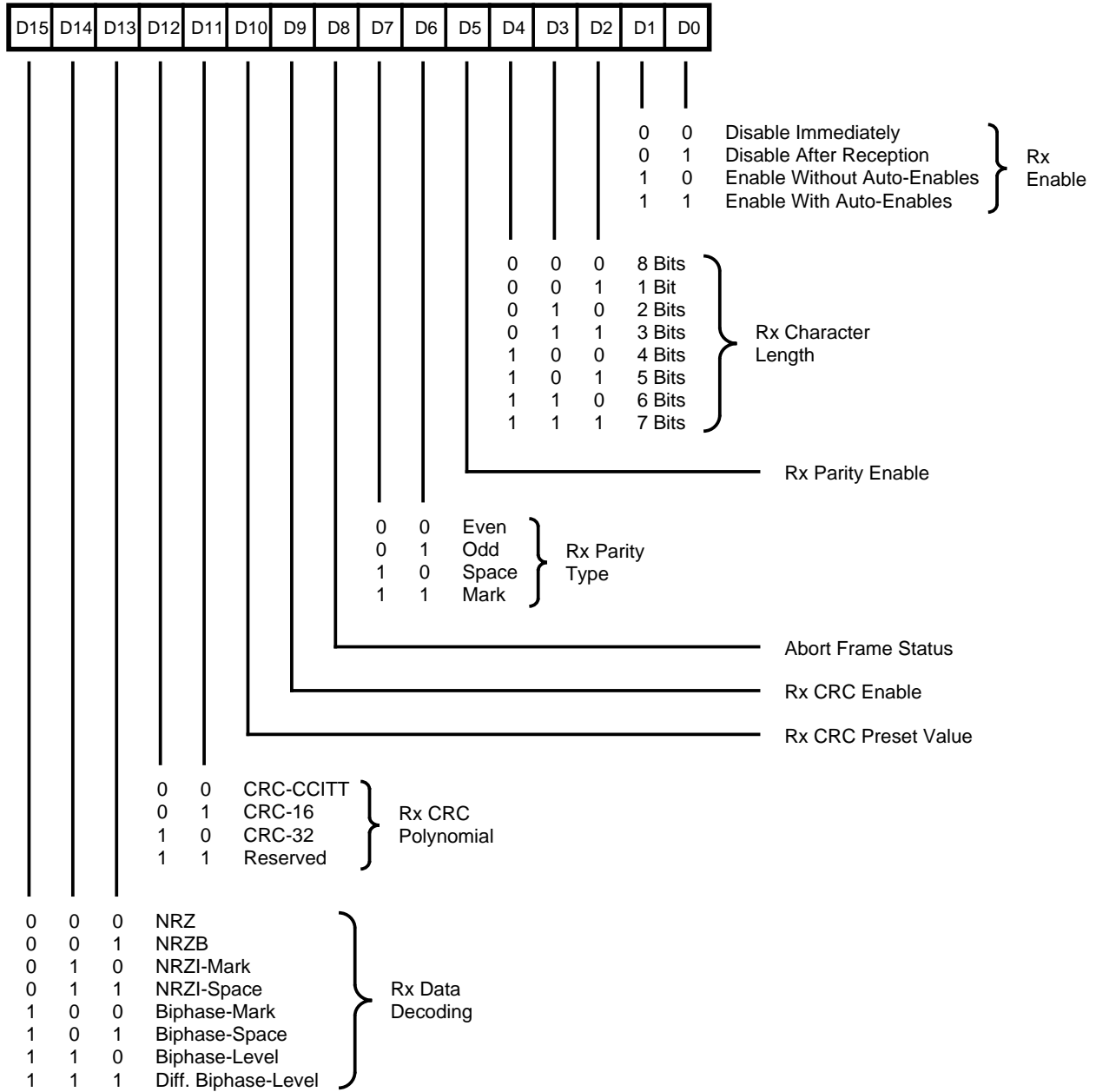

Figure 64. Receive Mode Register (RMR)

CONTROL REGISTERS (Continued)

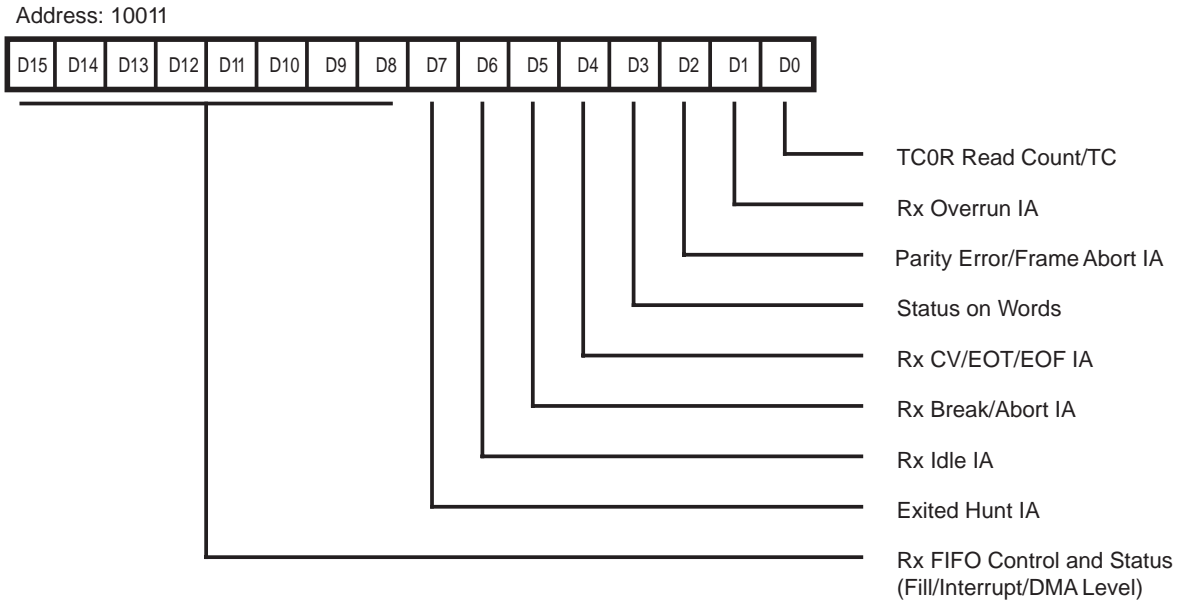

Figure 66a. Receive Interrupt Control Register (RICR)

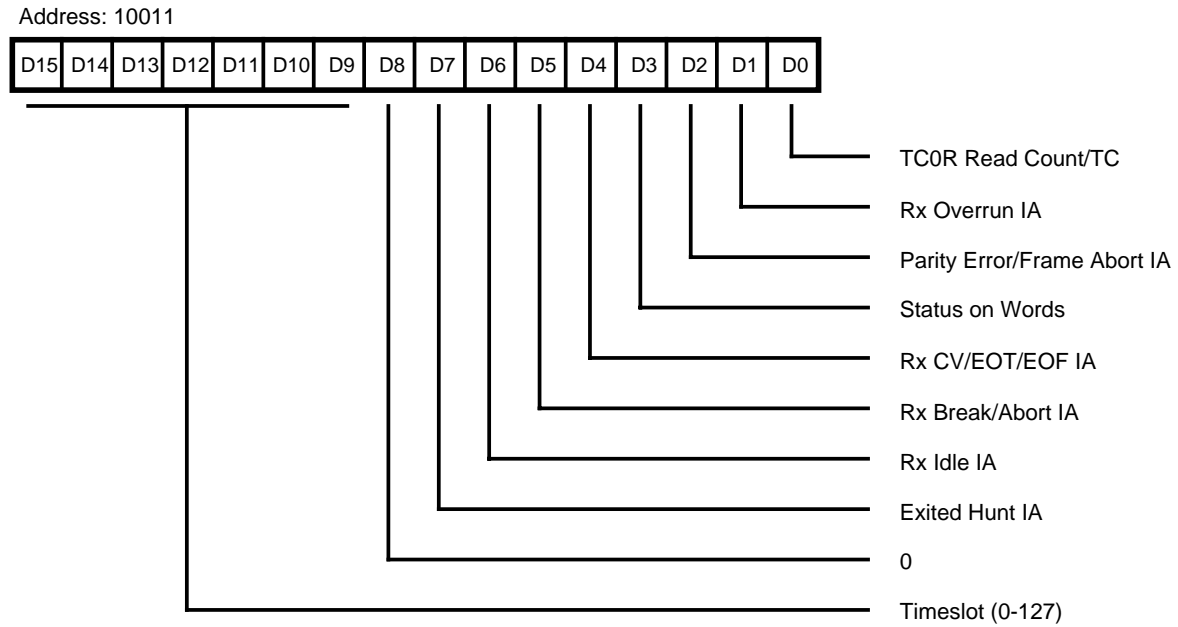

Figure 66b. Receive Interrupt Control Register (RICR)

Address: 10011

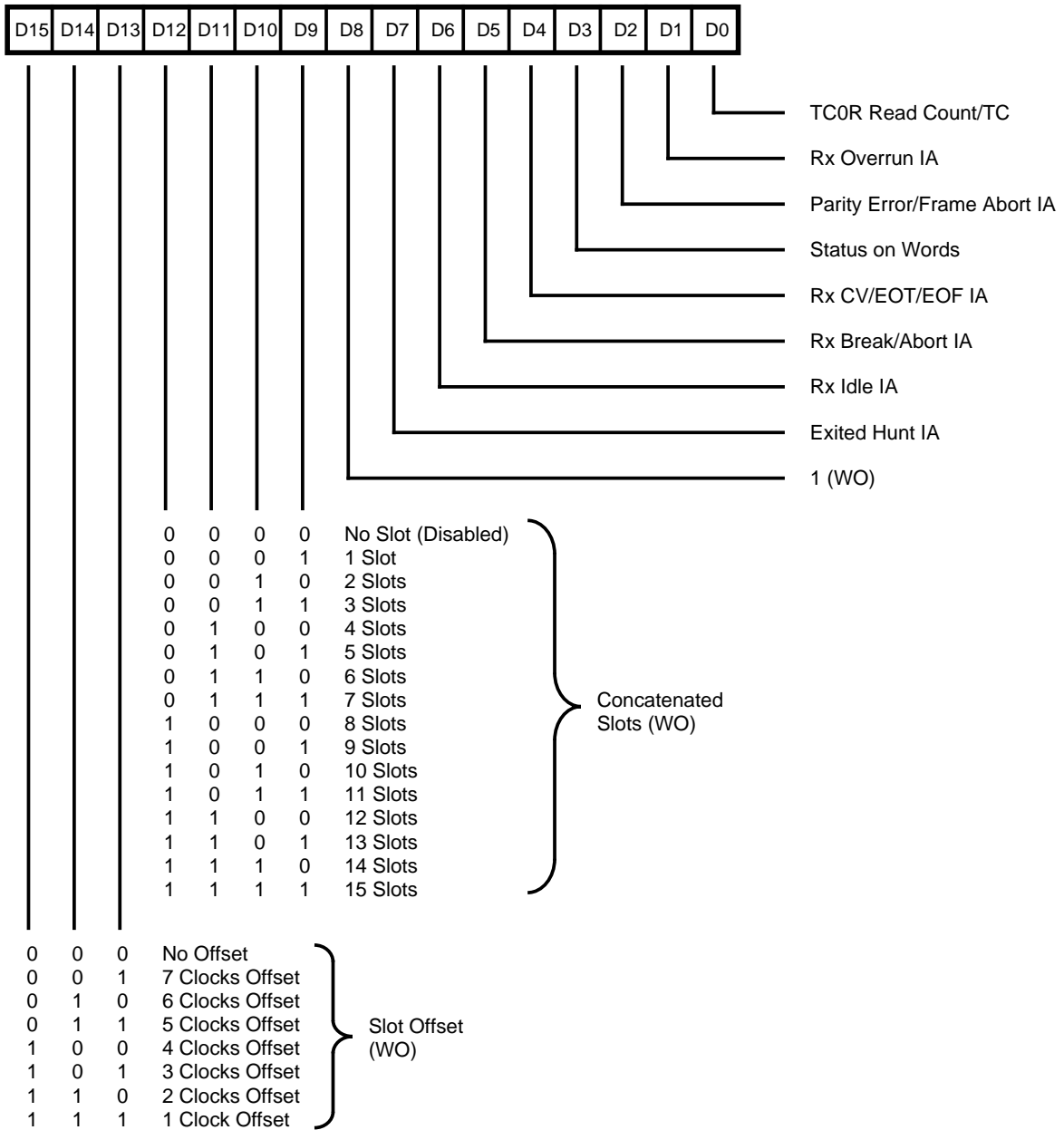

Figure 66c. Receive Interrupt Control Register (RICR)

CONTROL REGISTERS (Continued)

Address: 10100

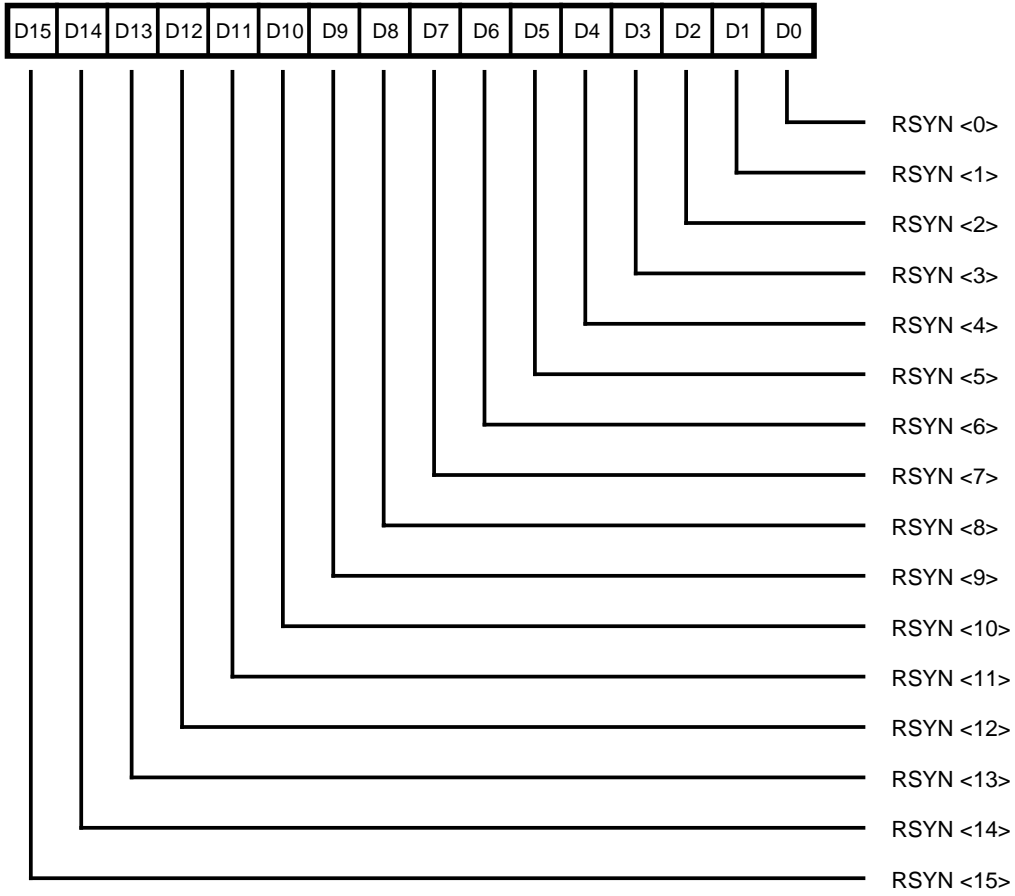

Figure 67. Receive Sync Register (RSR)

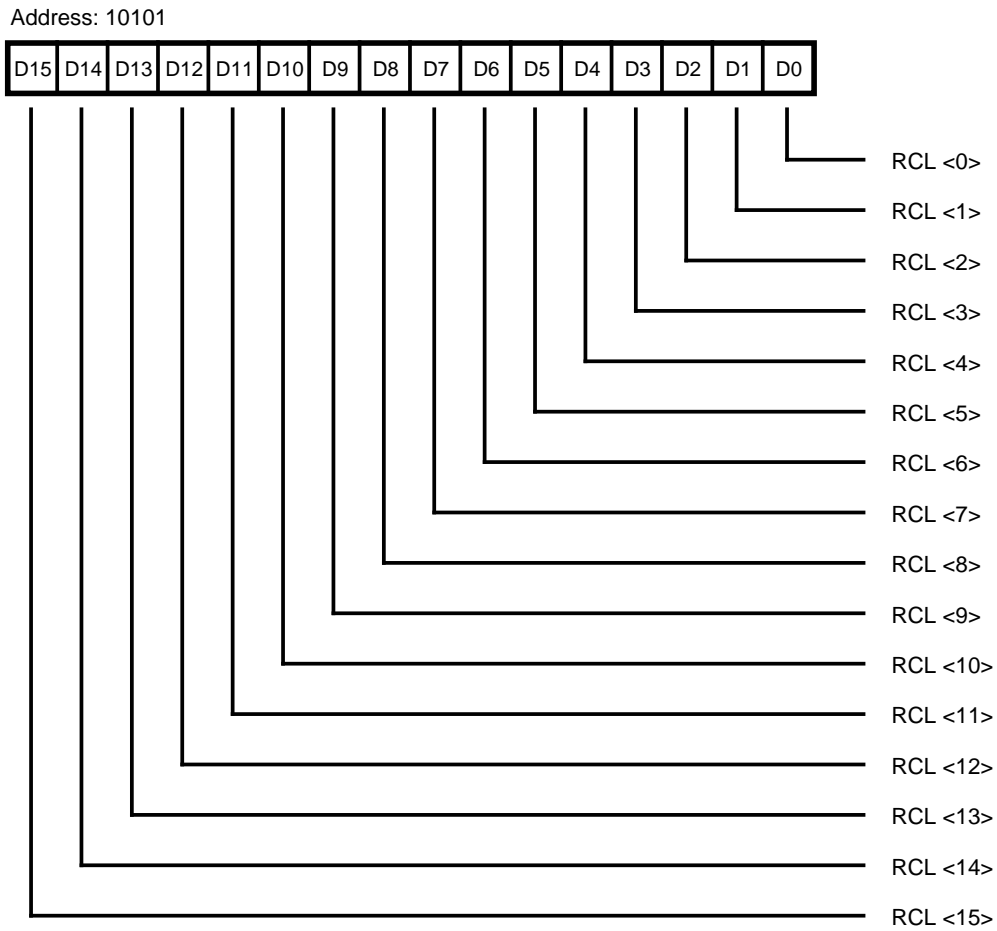

Figure 68. Receive Count Limit Register (RCLR)

CONTROL REGISTERS (Continued)

Address: 10110

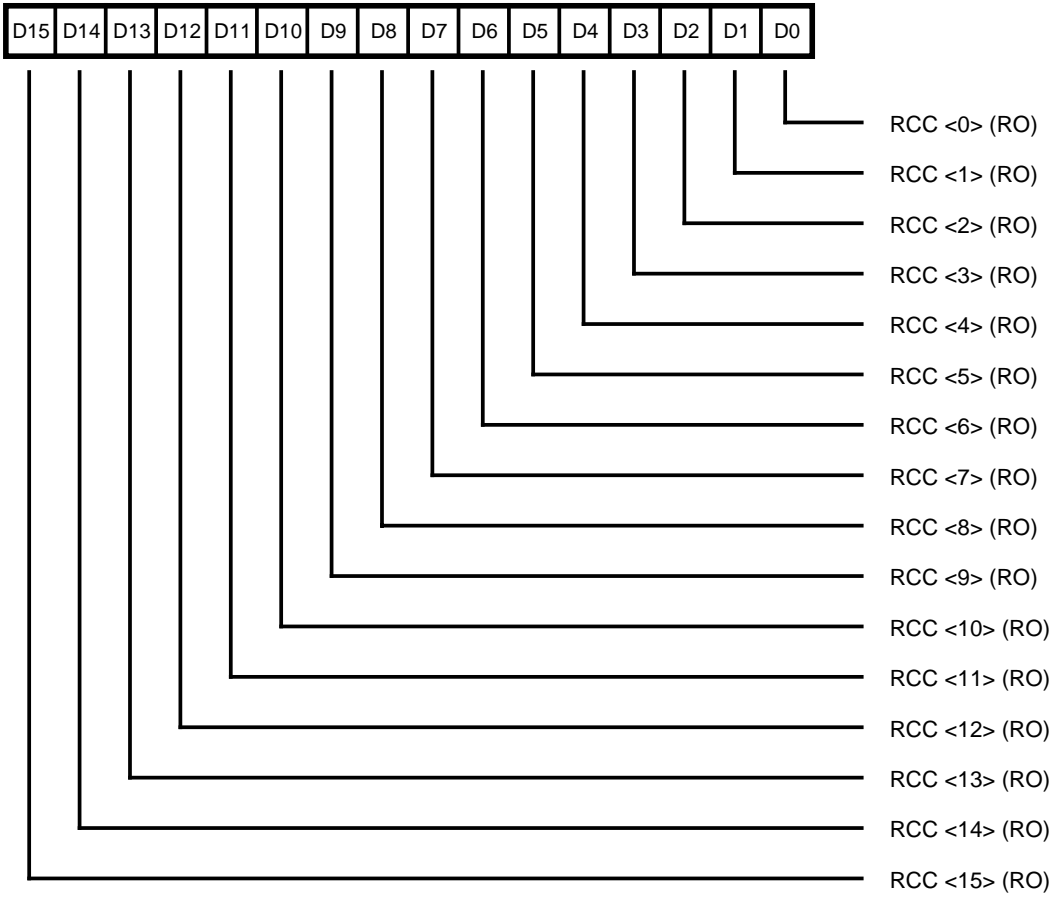

Figure 69. Receive Character Count Register (RCCR)

Address: 10111

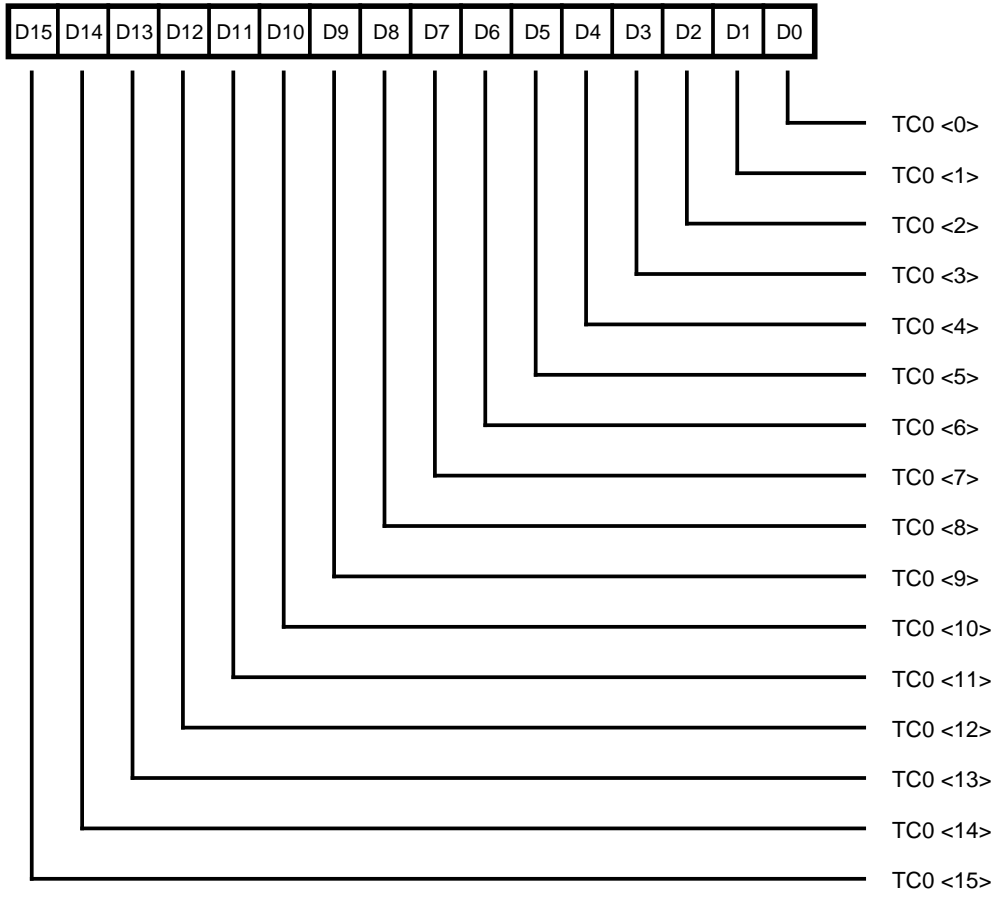

Figure 70. Time Constant 0 Register (TC0R)

CONTROL REGISTERS (Continued)

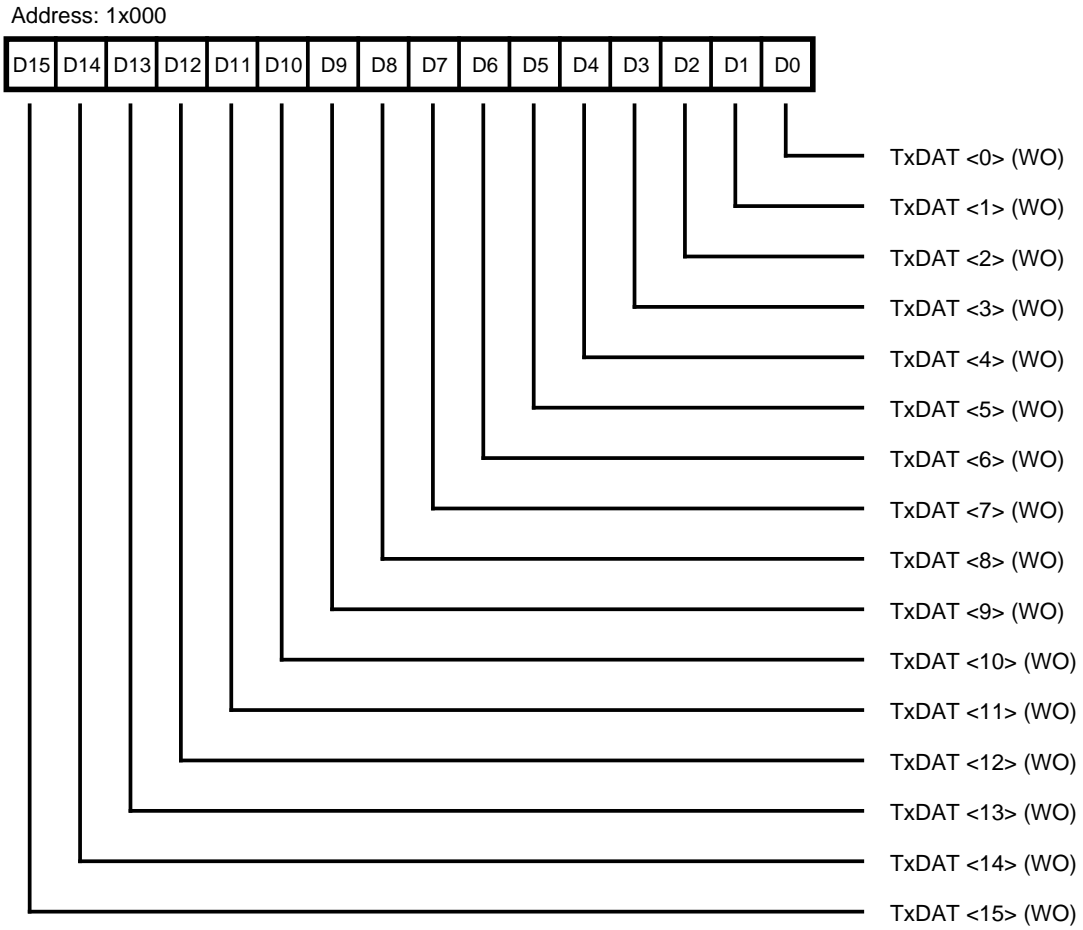

Figure 71. Transmit Data Register (TDR)

Address: 11001

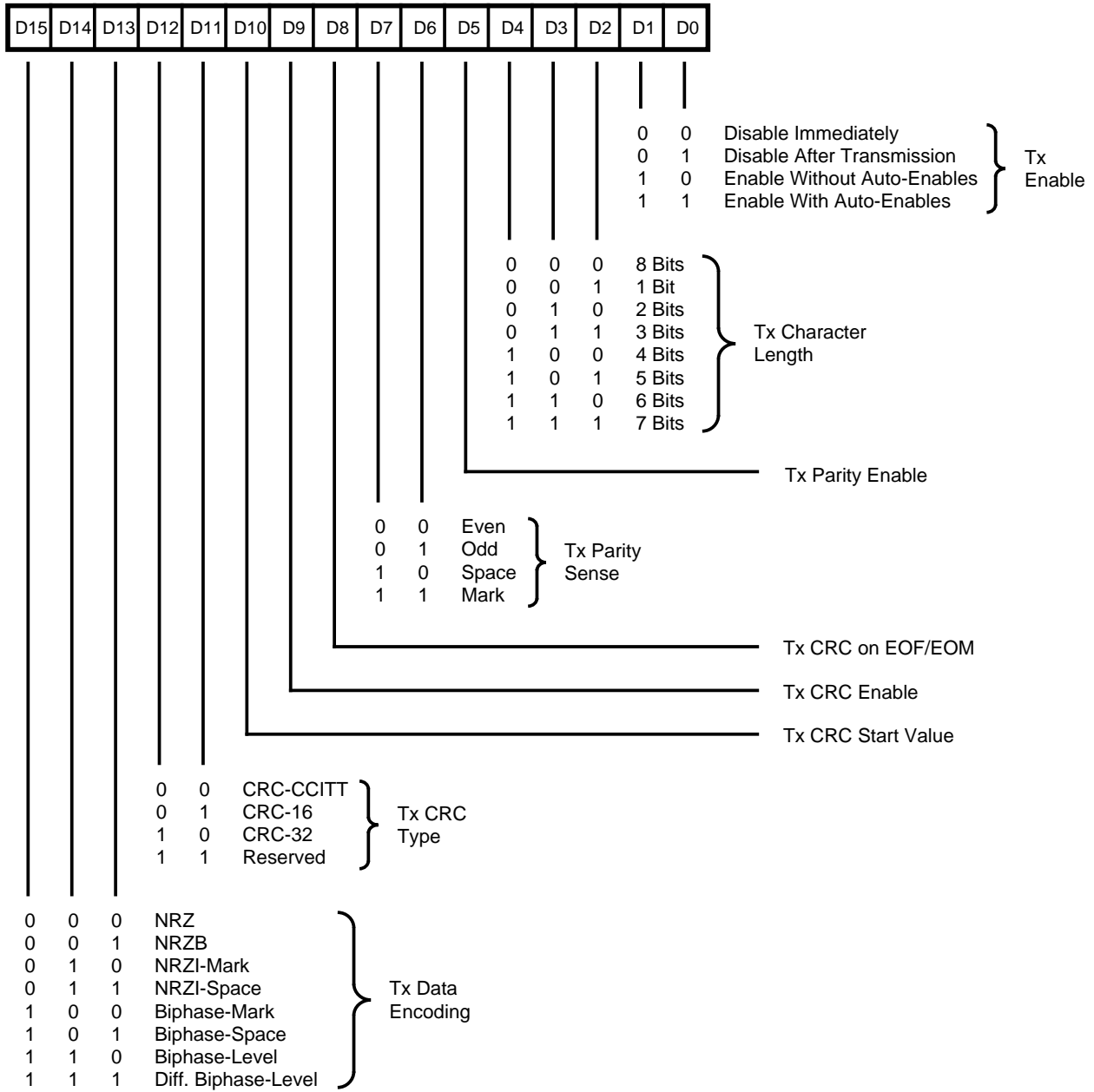

Figure 72. Transmit Mode Register (TMR)

CONTROL REGISTERS (Continued)

Address: 11010

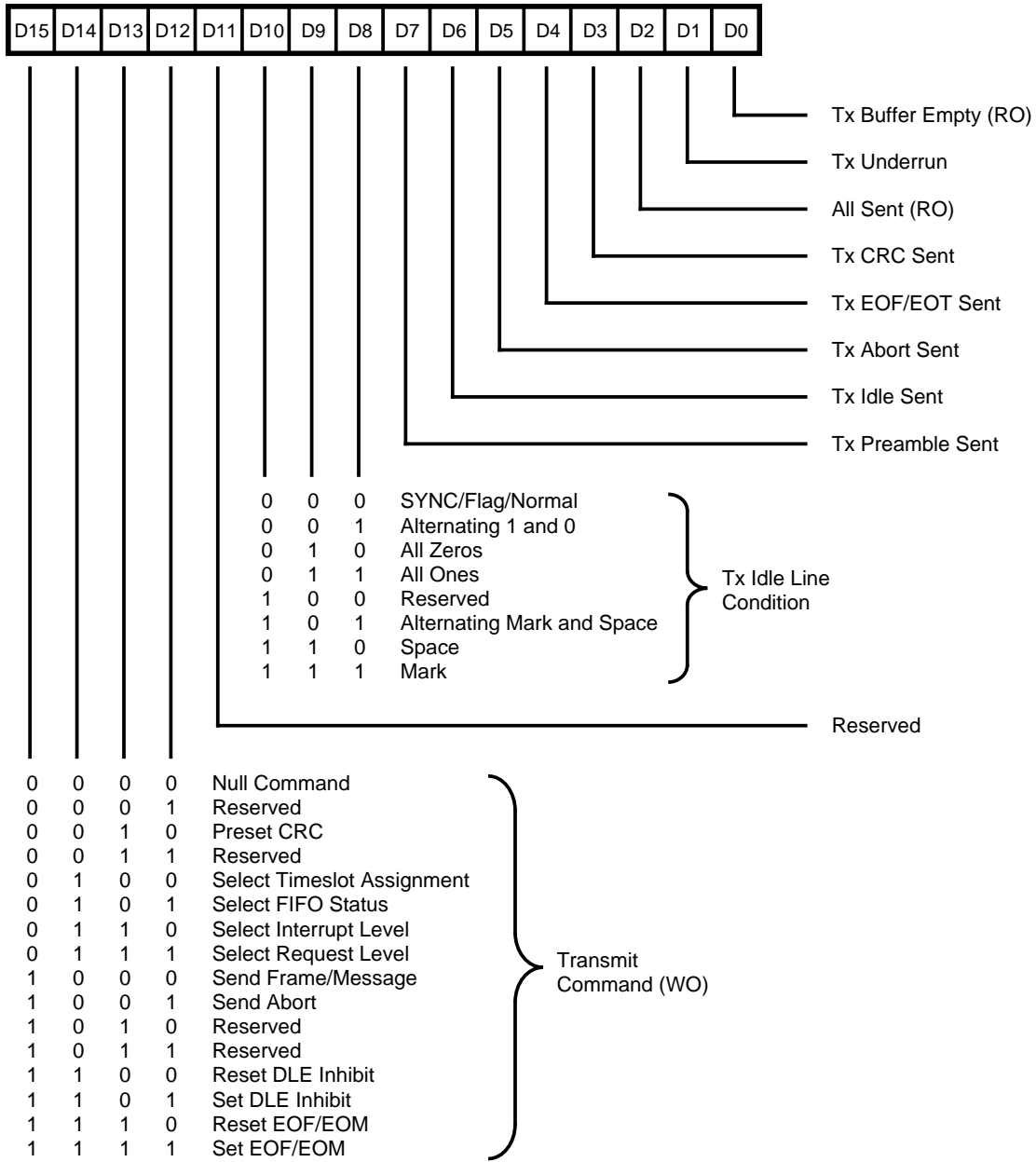

Figure 73. Transmit Command/Status Register (TCSR)

Address: 11011

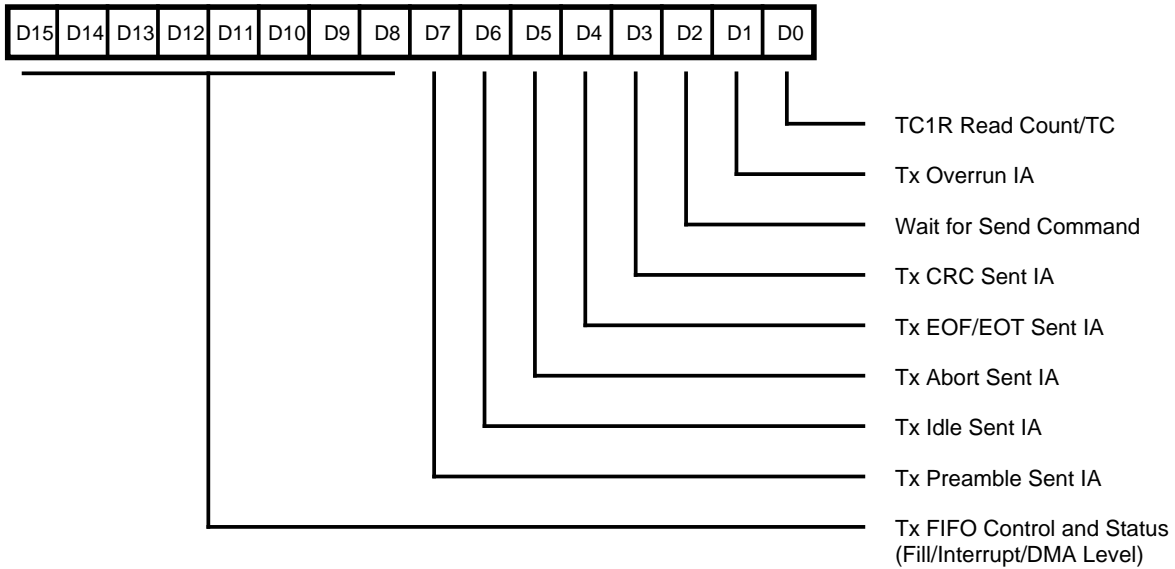

Figure 74a. Transmit Interrupt Control Register (TICR)

Address: 11011

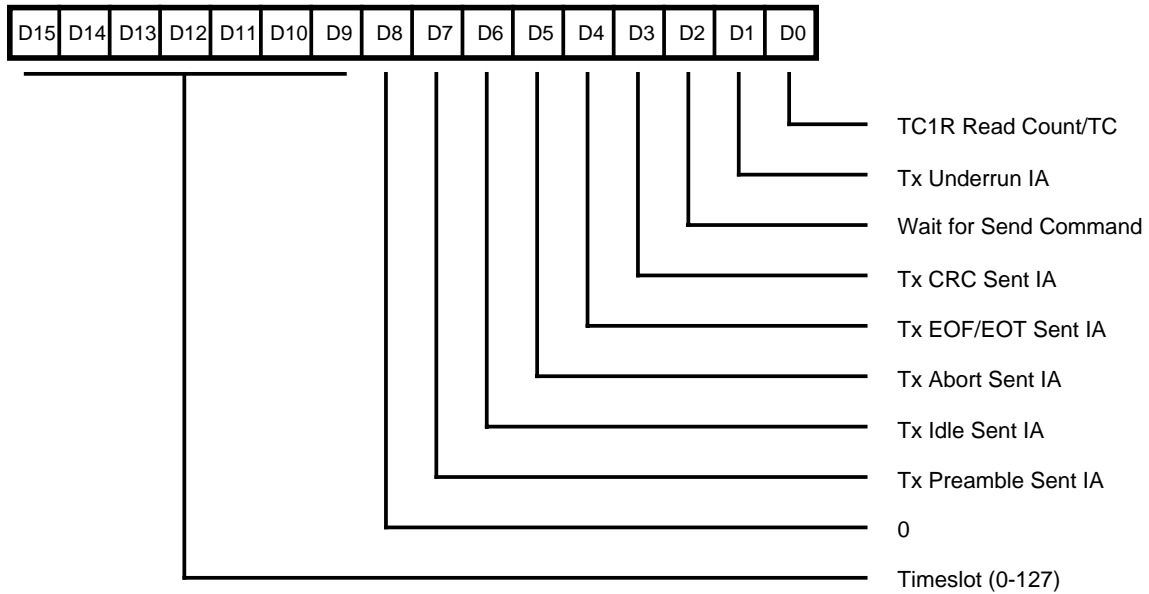

Figure 74b. Transmit Interrupt Control Register (TICR)

CONTROL REGISTERS (Continued)

Address: 11011

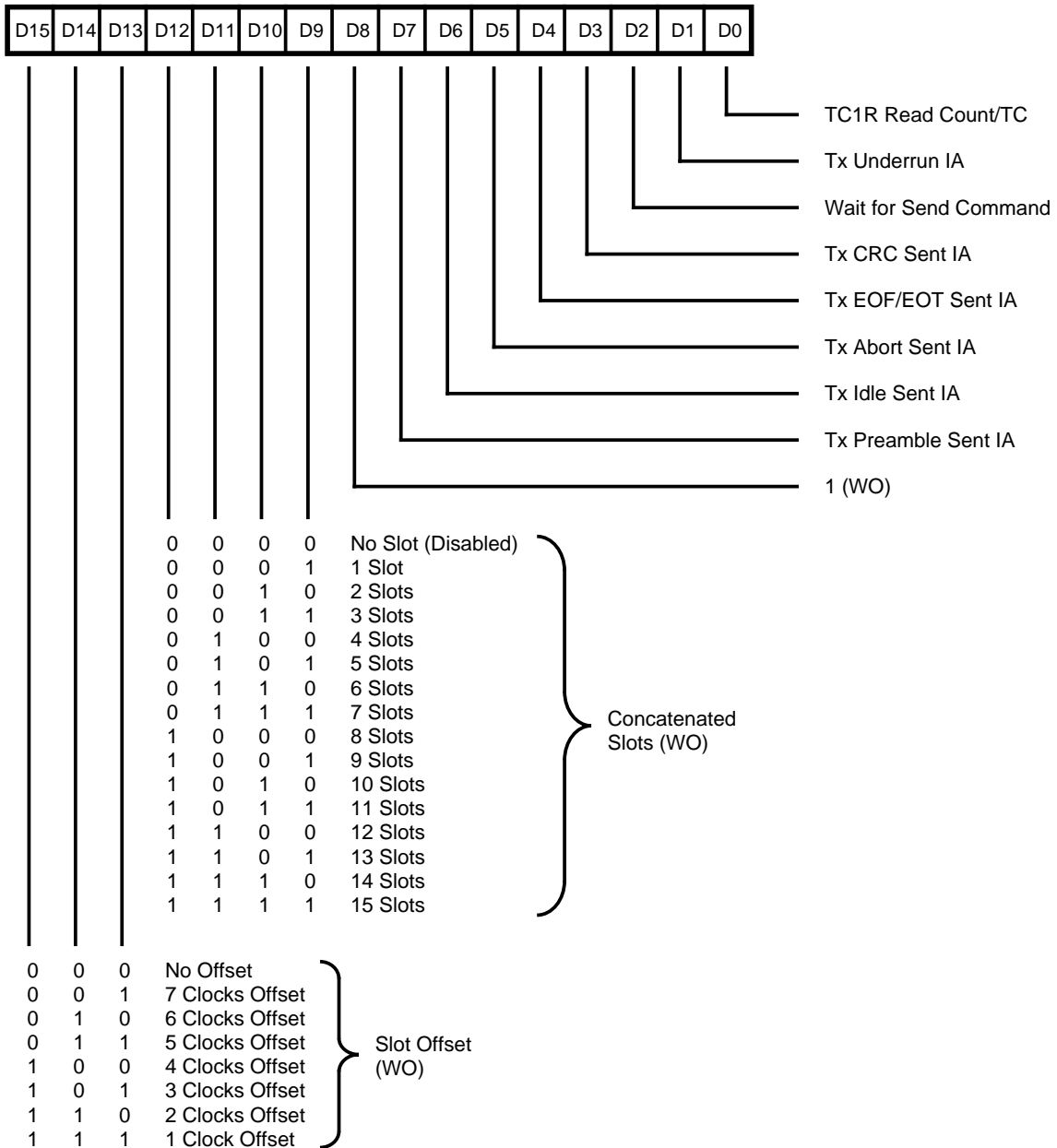

Figure 74c. Transmit Interrupt Control Register (TICR)

Address: 11100

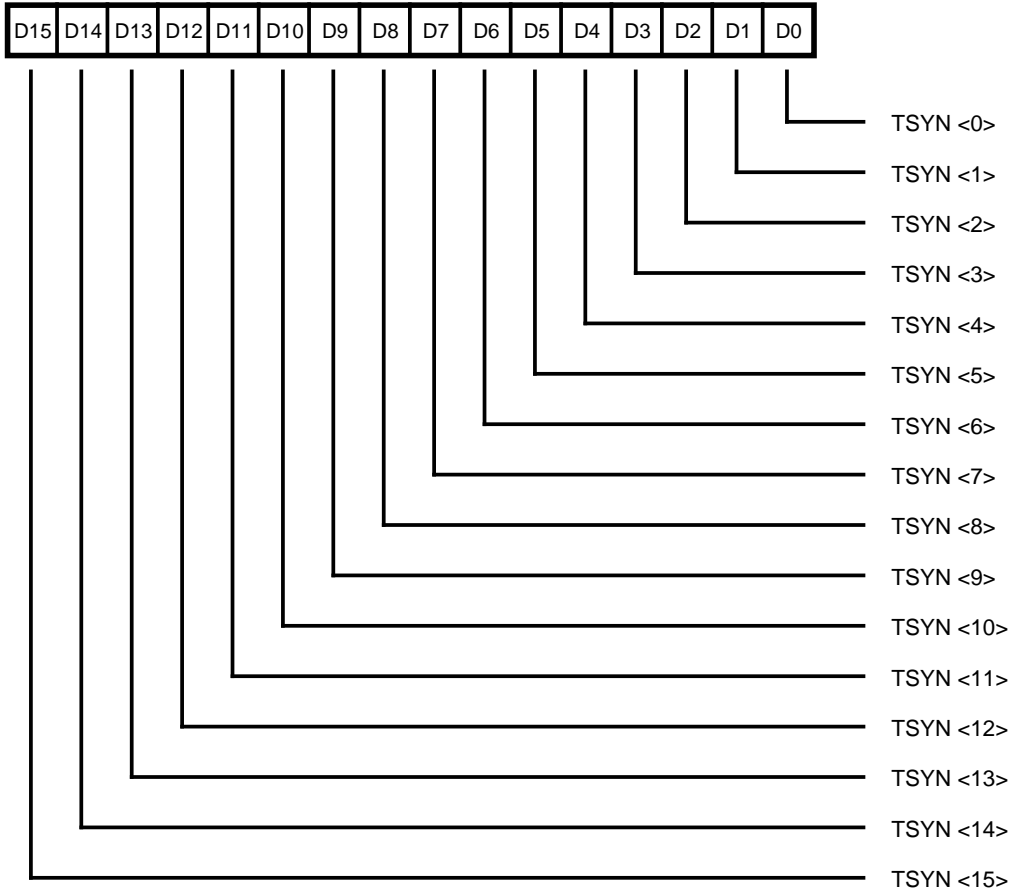

Figure 75. Transmit Sync Register (TSR)

CONTROL REGISTERS (Continued)

Address: 11101

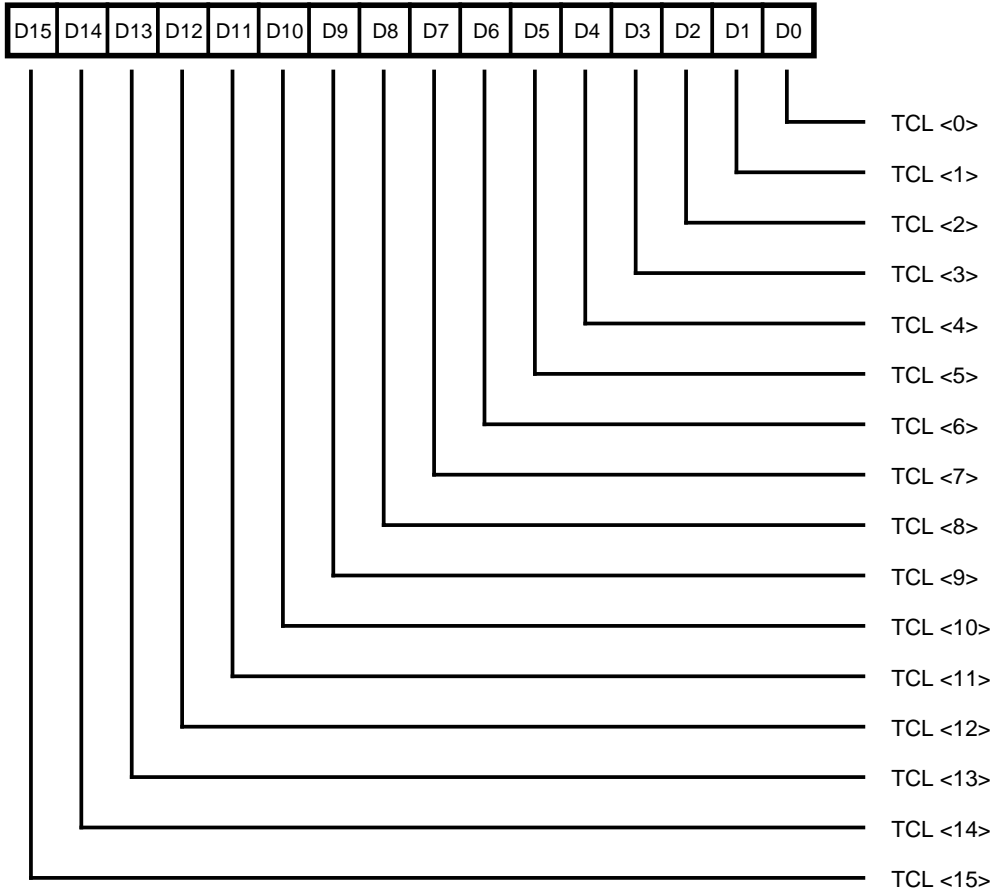

Figure 76. Transmit Count Limit Register (TCLR)

Address: 11110

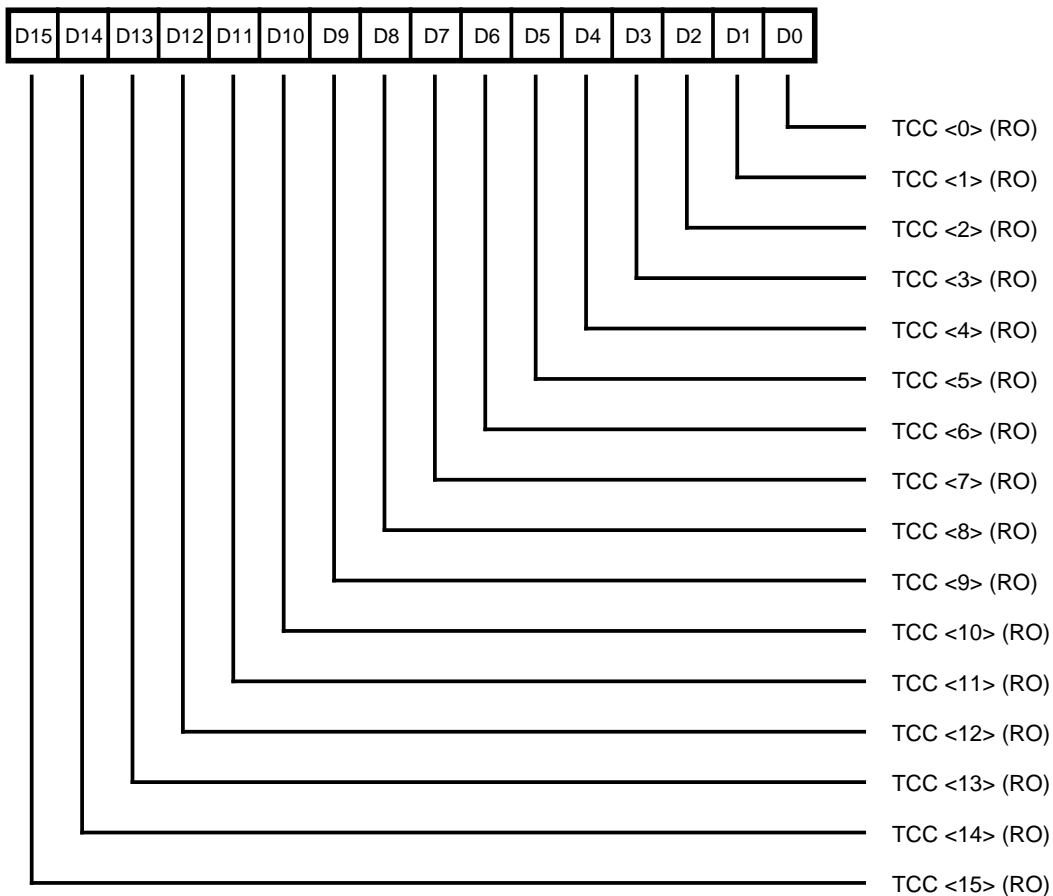

Figure 77. Transmit Character Count Register (TCCR)

CONTROL REGISTERS (Continued)

Address: 11111

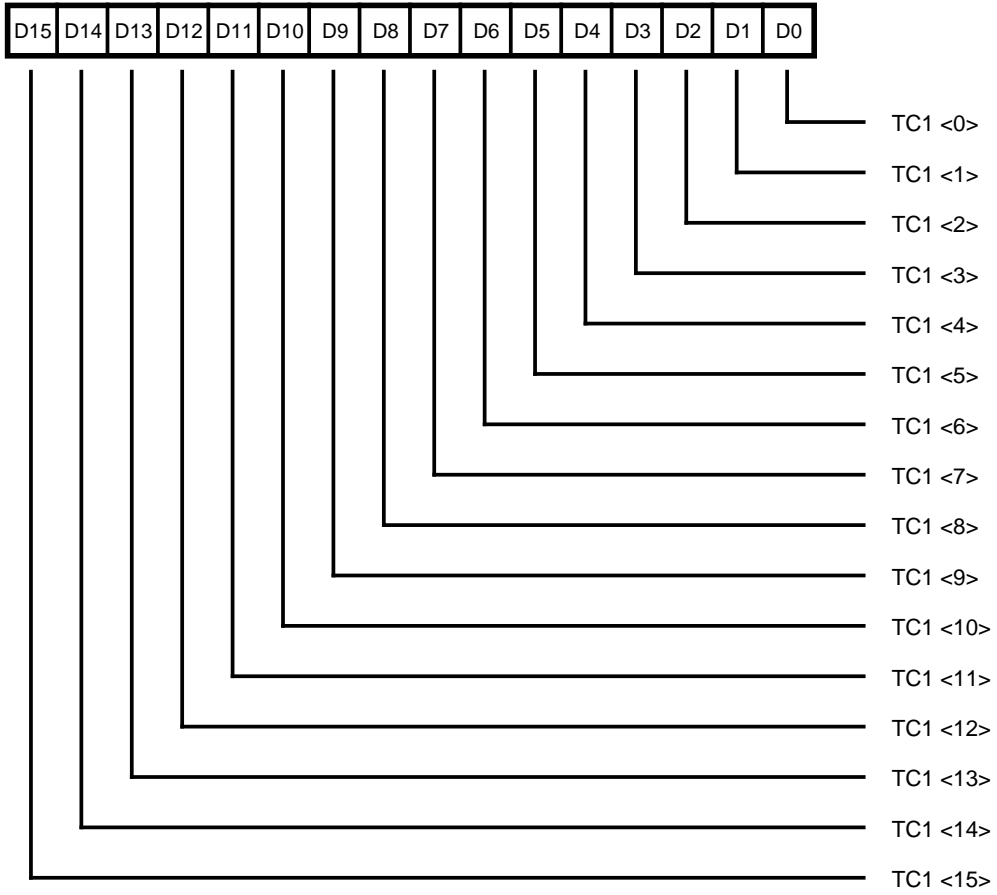
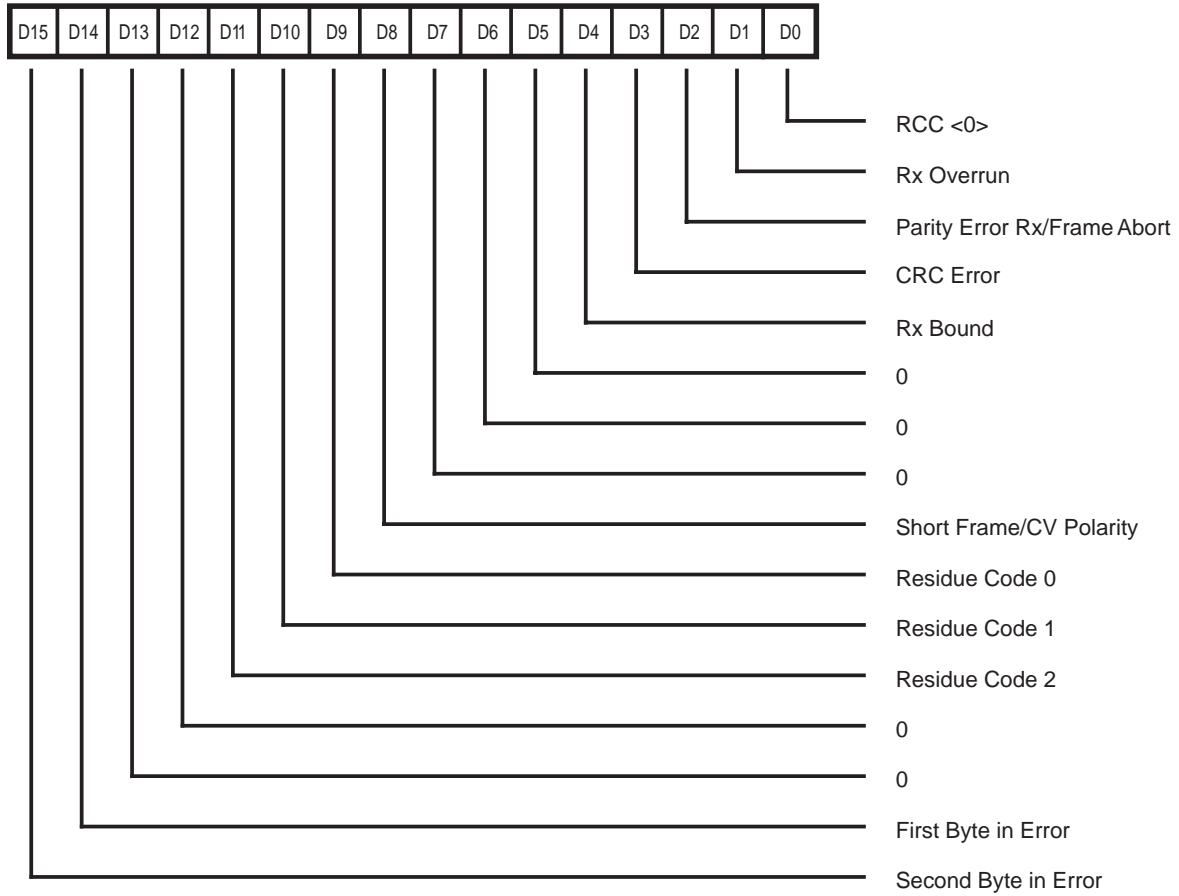

Figure 78. Time Constant 1 Register (TC1R)

Address: None *



* Refer to Figure 22 (Channel Control Register)
Bits 6-7 for Access Method

Figure 79. Receive Status Block Register (RSBR)

CONTROL REGISTERS (Continued)

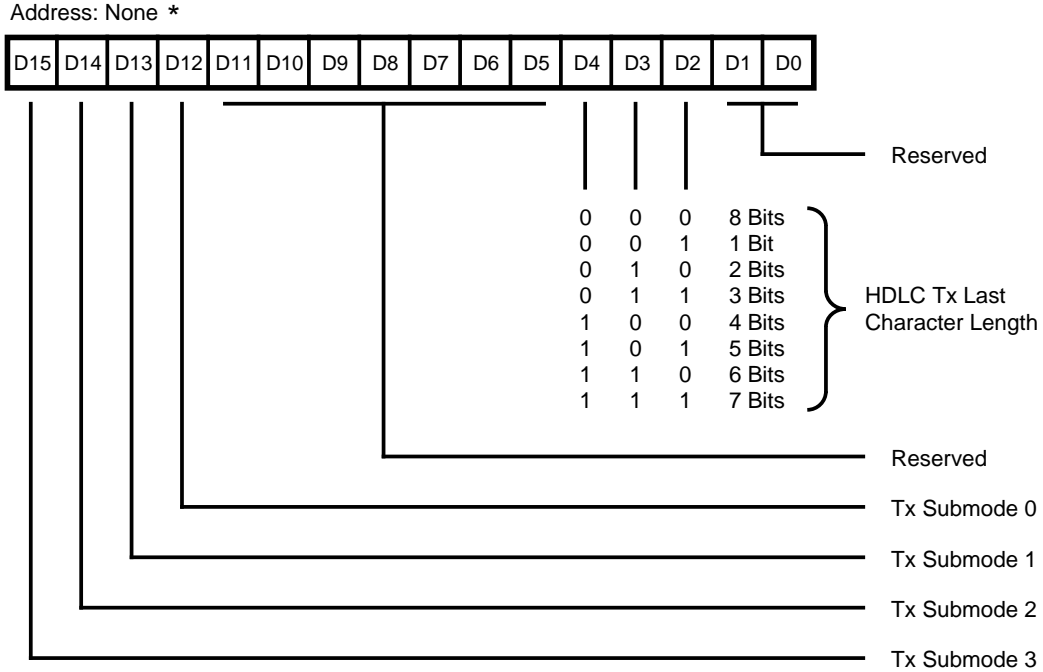

* Refer to Figure 22 (Channel Control Register) Bits15-14 for Access Method

Figure 80. Transmit Status Block Register (TSBR)

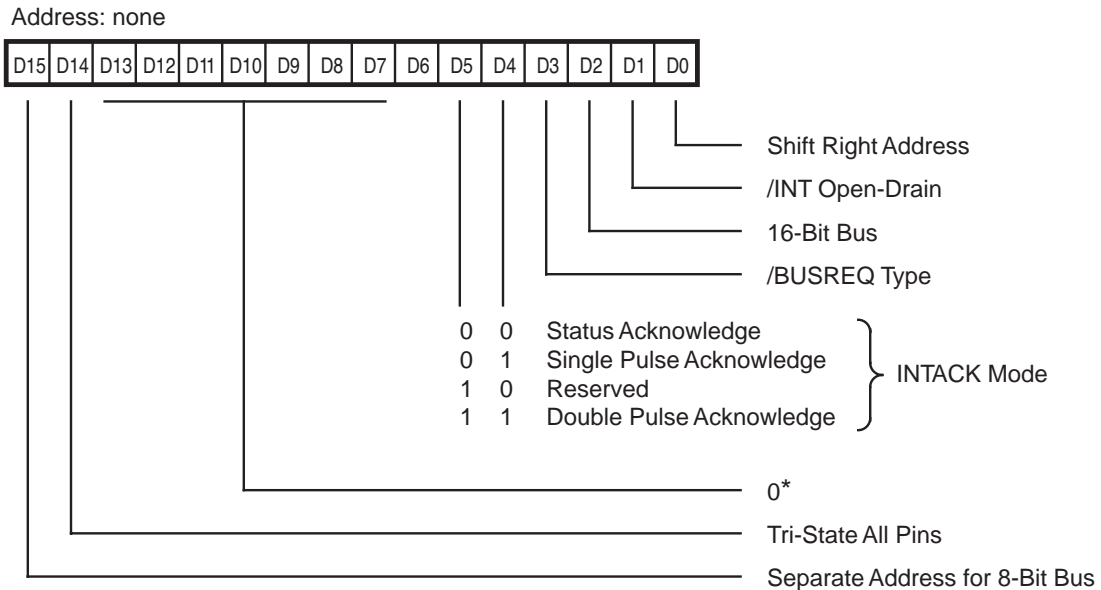

* Must be programmed as 0.

Figure 81. Bus Configuration Register (BCR)

ABSOLUTE MAXIMUM RATINGS

Symbol	Description	Min	Max	Units
V_{CC}	Supply Voltage (*)	-0.3	+7.0	V
T_{STG}	Storage Temp	-65°	+150°	C
T_A	Oper Ambient Temp		†	C
	Power Dissipation		2.2	W

Notes:

* Voltage on all pins with respect to GND.

† See Ordering Information.

Stresses greater than those listed under Absolute Maximum Ratings may cause permanent damage to the device. This is a stress rating only; operation of the device at any condition above those indicated in the operational sections of these specifications is not implied. Exposure to absolute maximum rating conditions for extended periods may affect device reliability.

STANDARD TEST CONDITIONS

The DC Characteristics and Capacitance Section below apply for the following standard test conditions, unless otherwise noted. All voltages are referenced to Ground. Positive current flows into the referenced pin (Figure 82). Standard conditions are as follows:

- $+4.5\text{ V} < V_{CC} < +5.5\text{ V}$
- $GND = 0\text{ V}$
- T_A as specified in Ordering Information

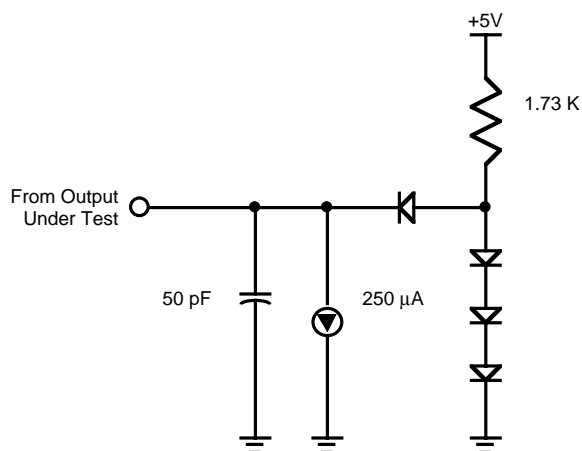

Figure 82. Standard Test Load

CAPACITANCE

Symbol	Parameter	Min	Max	Unit	Condition
C_{IN}	Input Capacitance		10	pF	*
C_{OUT}	Output Capacitance		15	pF	*
$C_{I/O}$	Bidirectional Capacitance		20	pF	

Notes:

F = 1 MHz, over specified temperature range.

* Unmeasured pins returned to Ground.

MISCELLANEOUS

Transistor Count - 100,000

TEMPERATURE RANGE

Standard = 0°C to 70°C

IUSC TIMING

The IUSC interface timing is similar to that found on a static RAM, except that it is much more flexible. Up to four separate timing strobe signals are present on the interface: /DS, /RD, /WR and /INTACK. Only one of these timing strobes is active at any time. Should the external logic activate more than one of these strobes at the same time,

the IUSC will enter a pre-reset state. This state is only exited by a hardware reset. Do not allow overlap of timing strobes. The timing diagrams, beginning on the next page, illustrate the different bus transactions possible with the necessary setup, hold, and delay times. IUSC Timing diagrams are shown from Figure 83 through Figure 107.

DC CHARACTERISTICS

Symbol	Parameter	Min	Typ	Max	Unit	Condition
V_{IH}	Input High Voltage	2.2		$V_{CC} + 0.3$	V	
V_{IL}	Input Low Voltage	-0.3		0.8	V	
V_{OH1}	Output High Voltage	2.4			V	$I_{OH} = -1.6 \text{ mA}$
V_{OH2}	Output High Voltage	$V_{CC} - 0.8$			V	$I_{OH} = -250 \mu\text{A}$
V_{OL}	Output Low Voltage			0.4	V	$I_{OL} = +2.0 \text{ mA}$
I_{IL}	Input Leakage			+10.00	μA	$0.4 < V_{IN} < +2.4\text{V}$
I_{OL}	Output Leakage			+10.00	μA	$0.4 < V_{OUT} < +2.4\text{V}$
I_{CC1}	V_{CC} Supply Current		7	50	mA	$V_{CC} = 5\text{V}$ $V_{IH} = 4.8\text{V}$ $V_{IL} = 0.2\text{V}$

Note:

$V_{CC} = 5\text{V} \pm 10\%$ unless otherwise specified, over specified temperature range.

AC CHARACTERISTICS

Timing Diagrams (Figures 83-105)

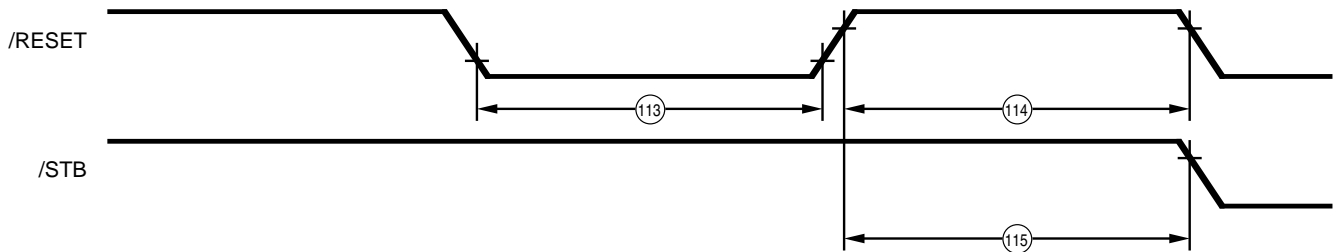

Figure 83. Reset Timing

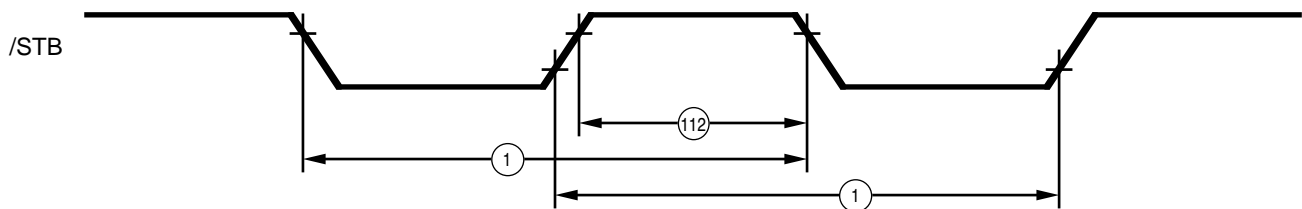

Figure 84. Bus Cycle Timing

Note:

/STB is any of the following: /DS, /RD, /WR or Pulsed /INTACK.

AC CHARACTERISTICS

Timing Diagrams (Continued)

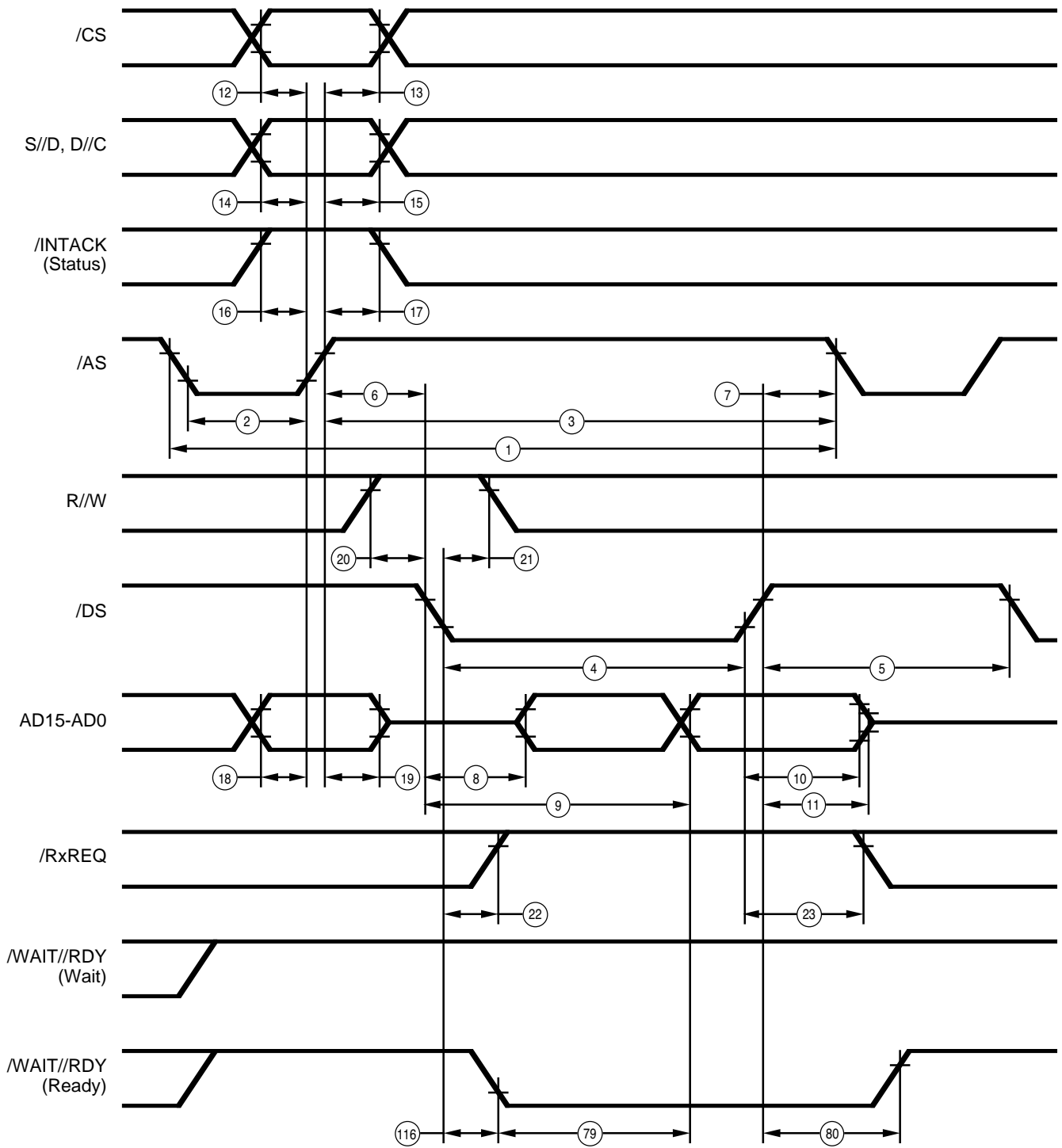

Figure 85. Multiplexed /DS Read Cycle

AC CHARACTERISTICS

Timing Diagrams (Continued)

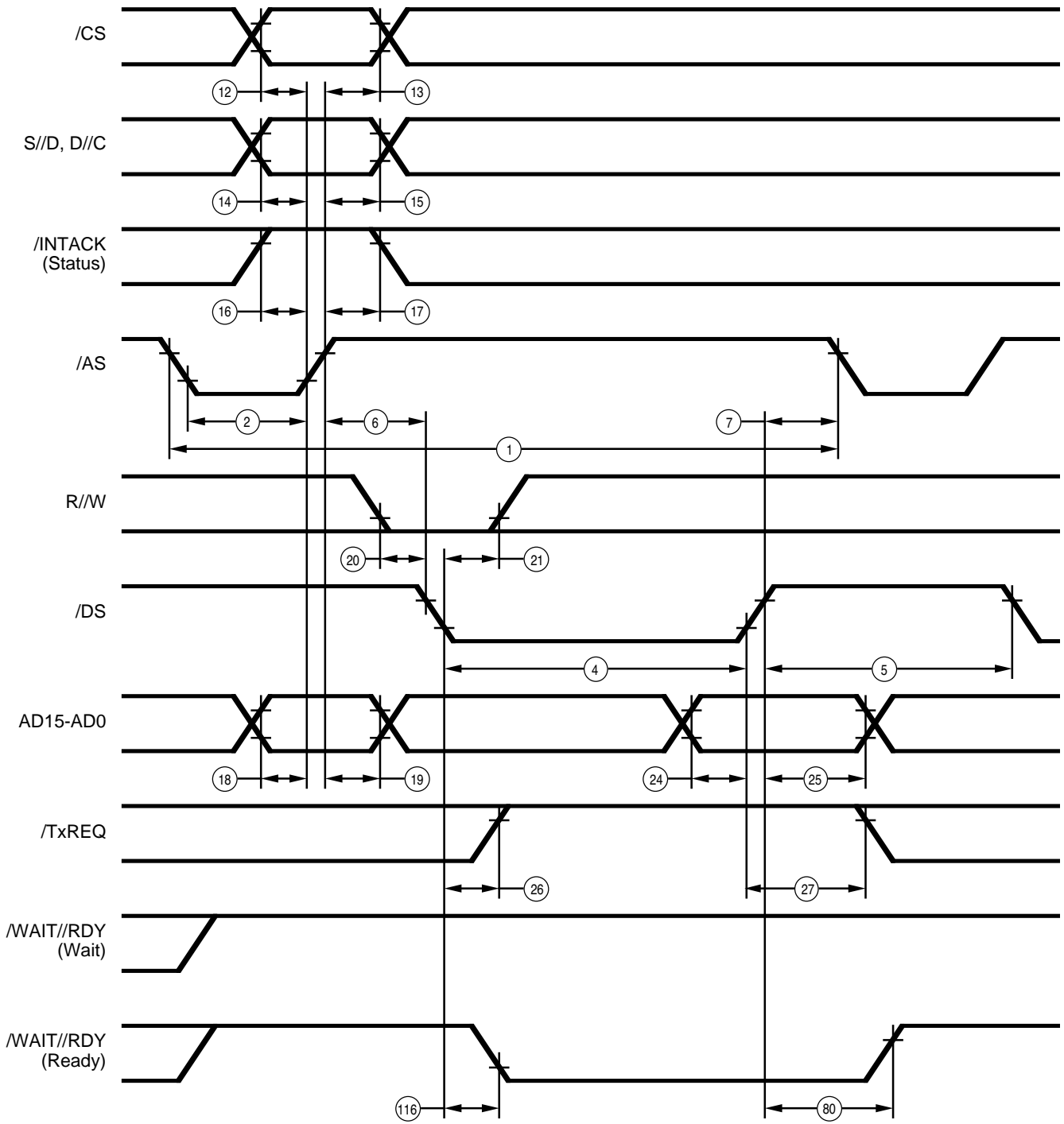

Figure 86. Multiplexed /DS Write Cycle

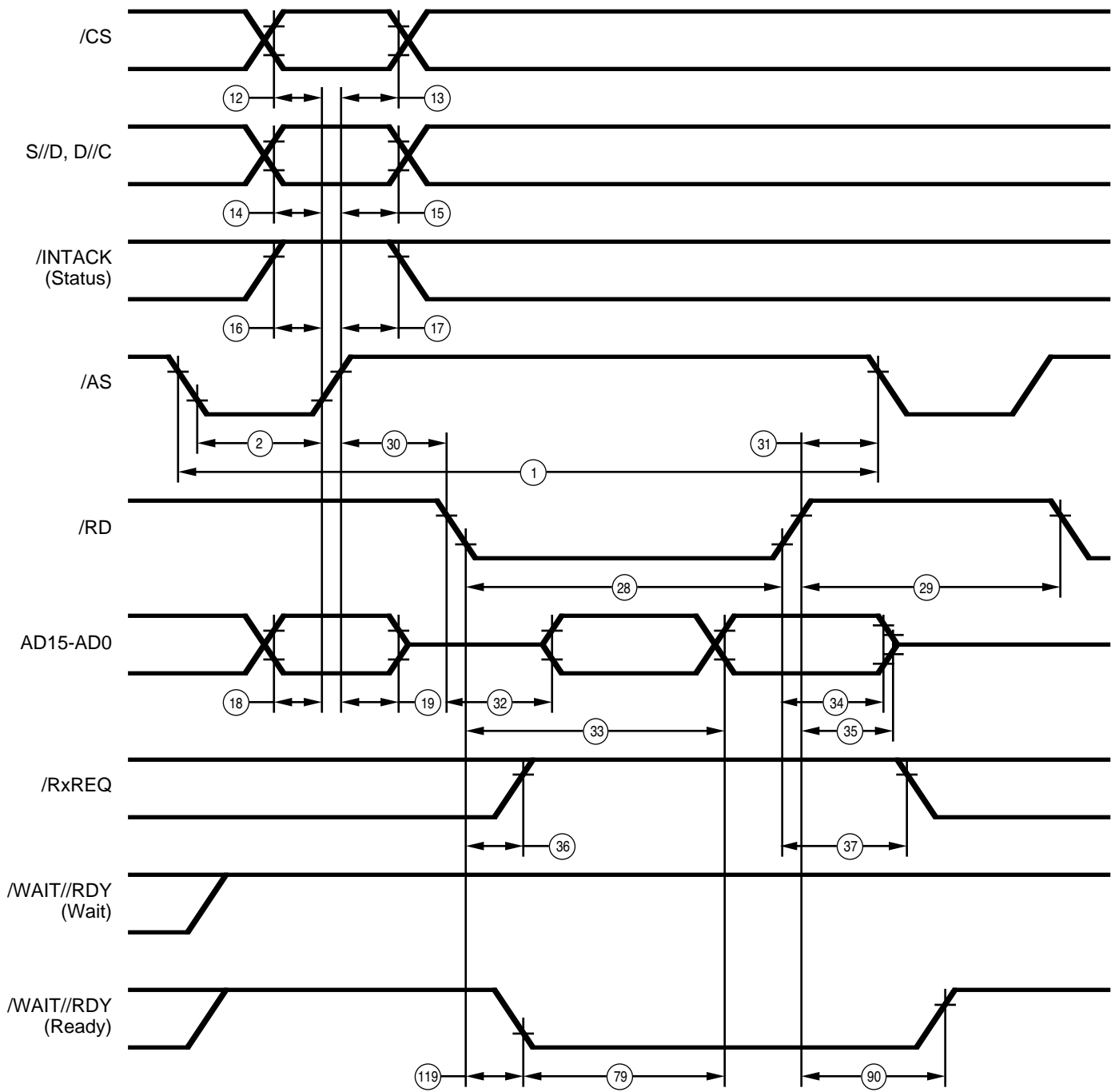

Figure 87. Multiplexed /RD Read Cycle

AC CHARACTERISTICS

Timing Diagrams (Continued)

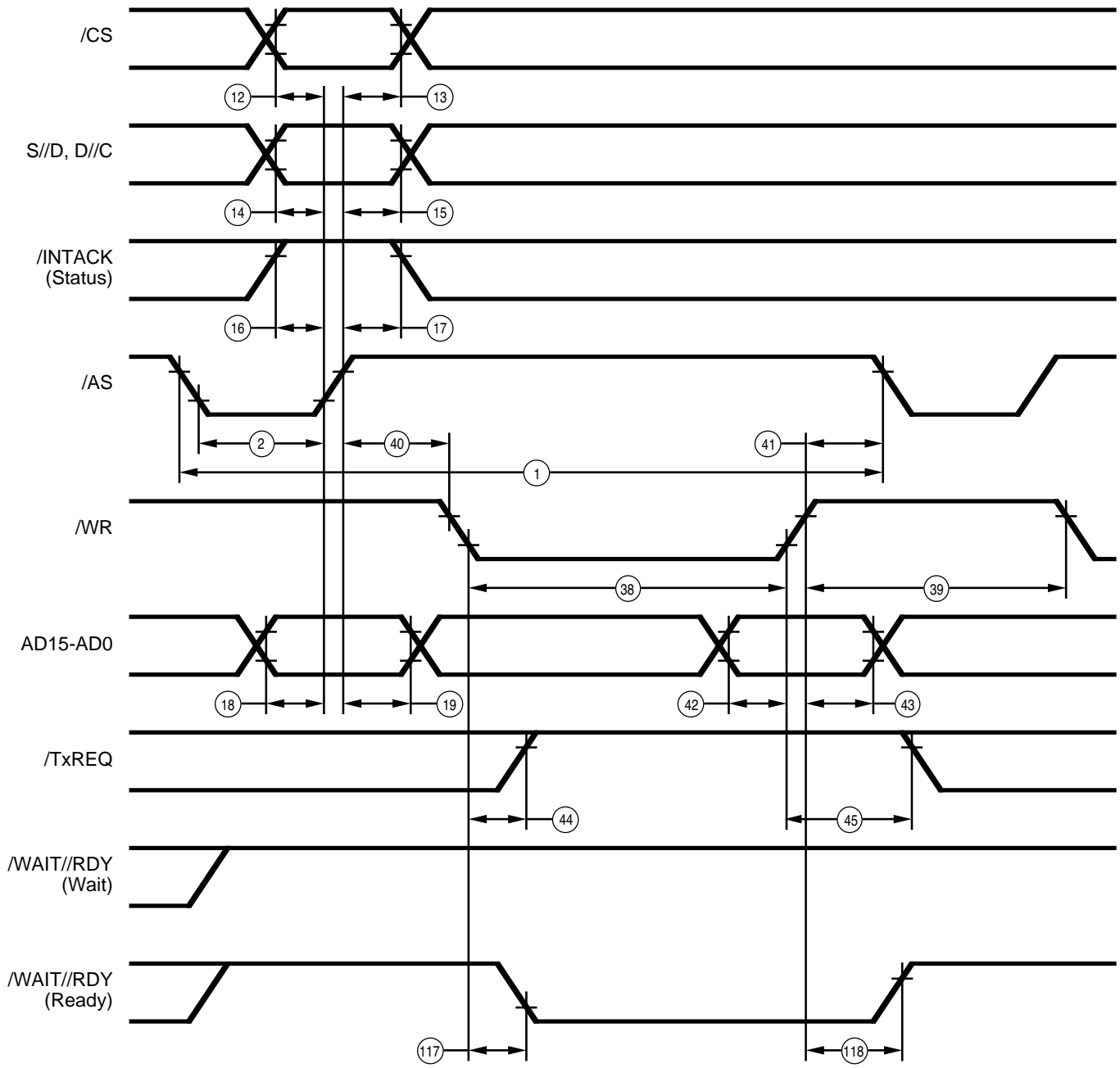

Figure 88. Multiplexed /WR Write Cycle

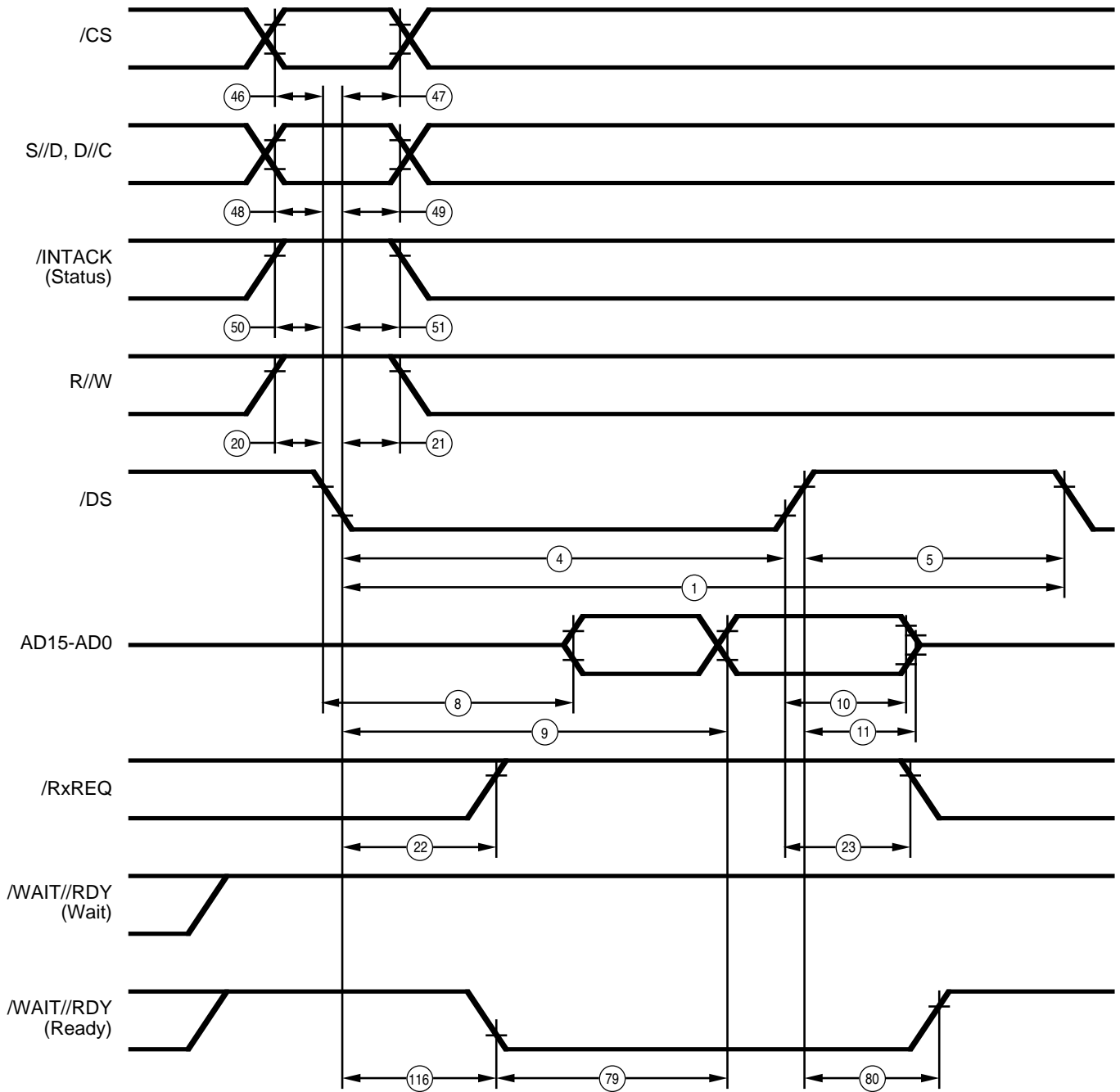

Figure 89. Non-Multiplexed /DS Read Cycle

AC CHARACTERISTICS

Timing Diagrams (Continued)

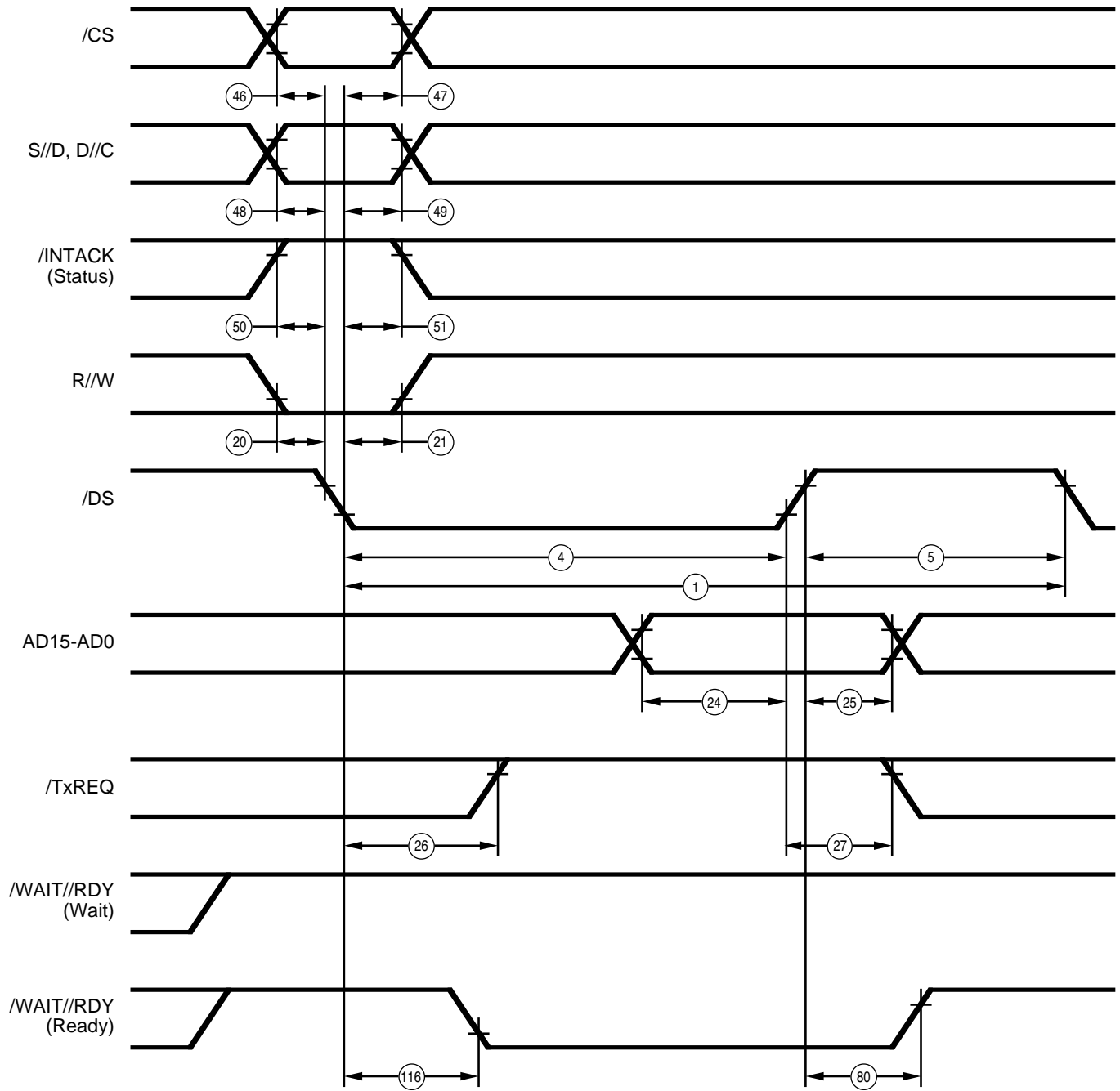

Figure 90. Non-Multiplexed /DS Write Cycle

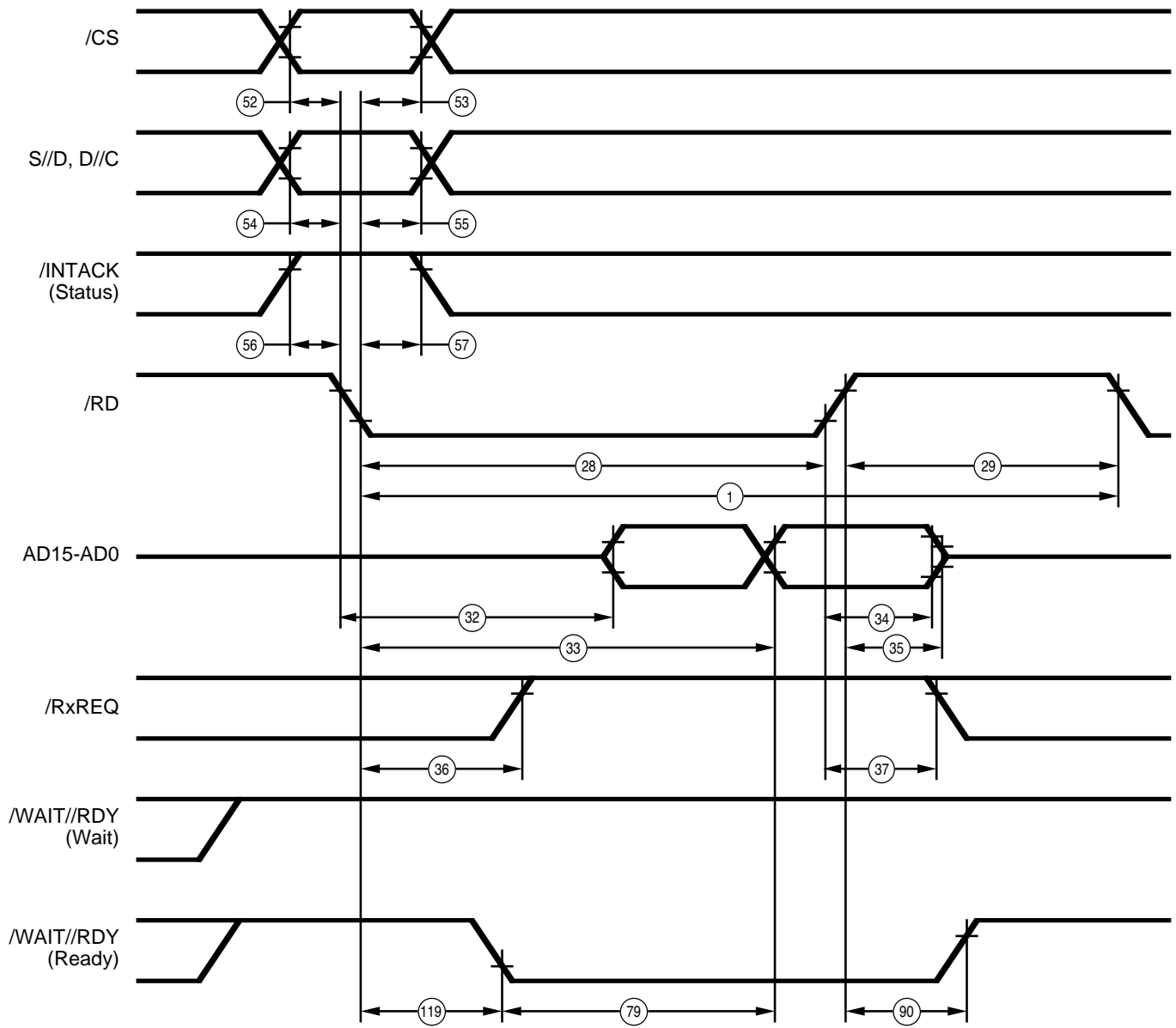

Figure 91. Non-Multiplexed /RD Read Cycle

AC CHARACTERISTICS

Timing Diagrams (Continued)

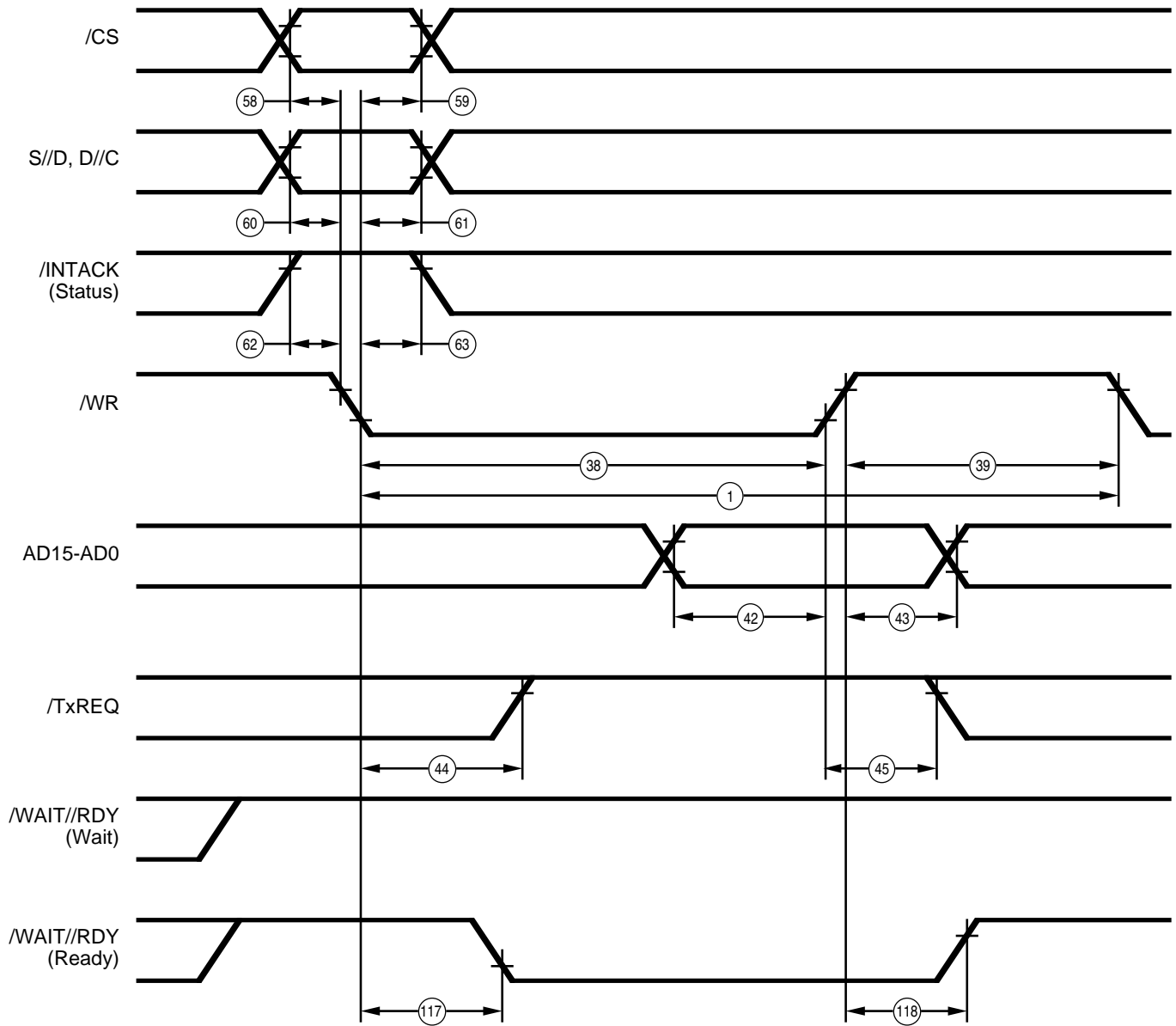

Figure 92. Non-Multiplexed /WR Write Cycle

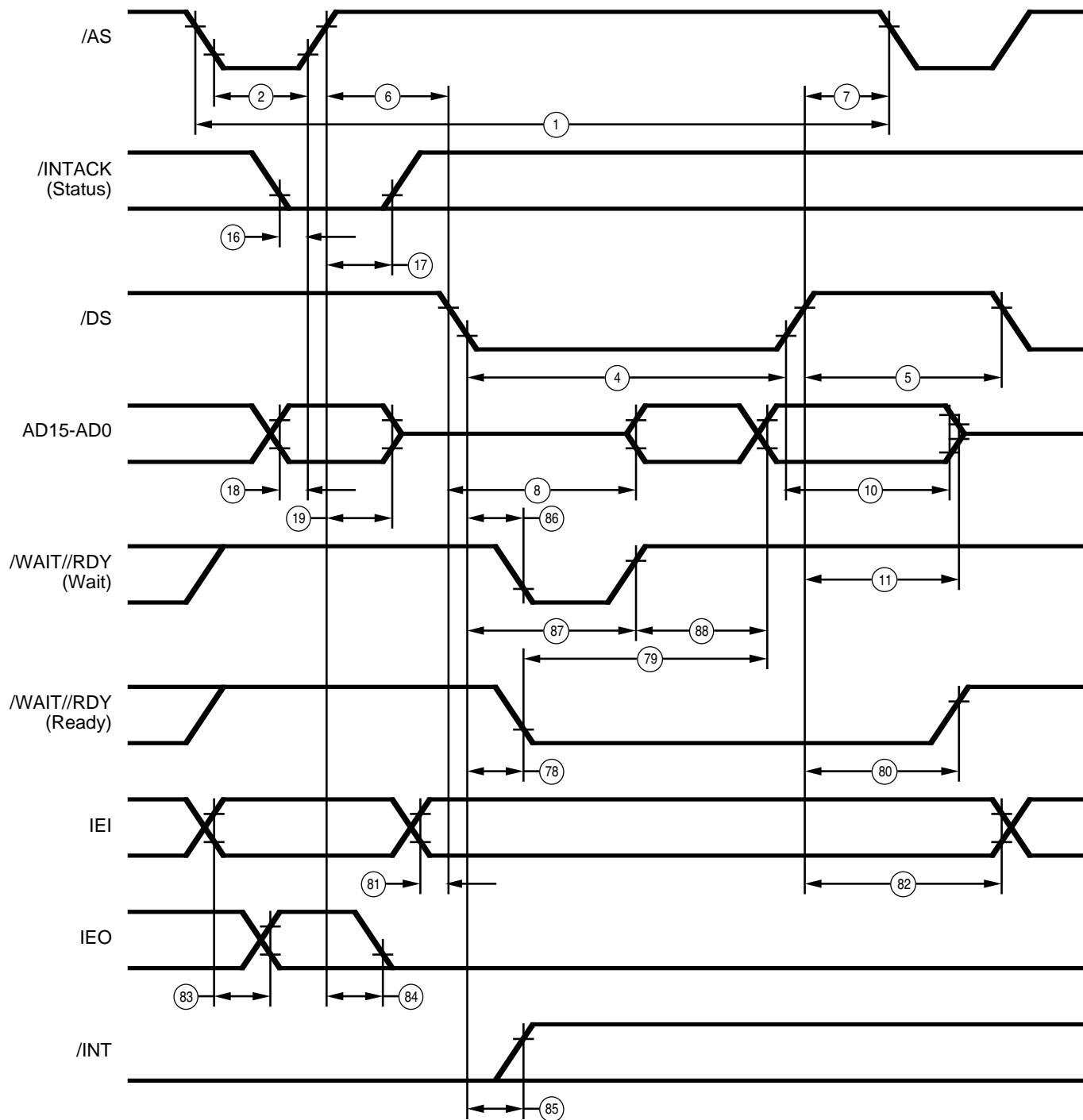

Figure 93. Multiplexed /DS Interrupt Acknowledge Cycle

AC CHARACTERISTICS

Timing Diagrams (Continued)

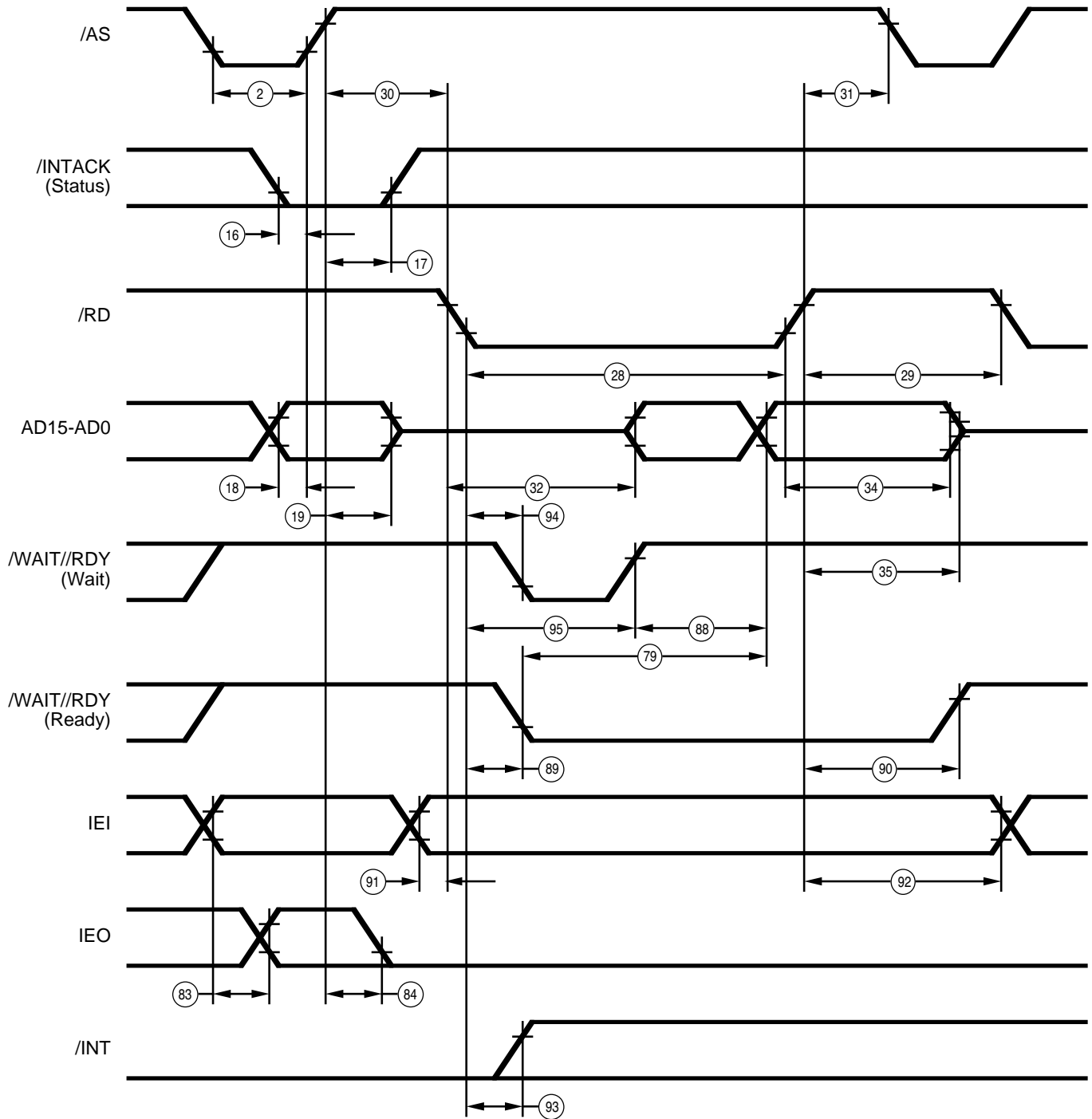

Figure 94. Multiplexed /RD Interrupt Acknowledge Cycle

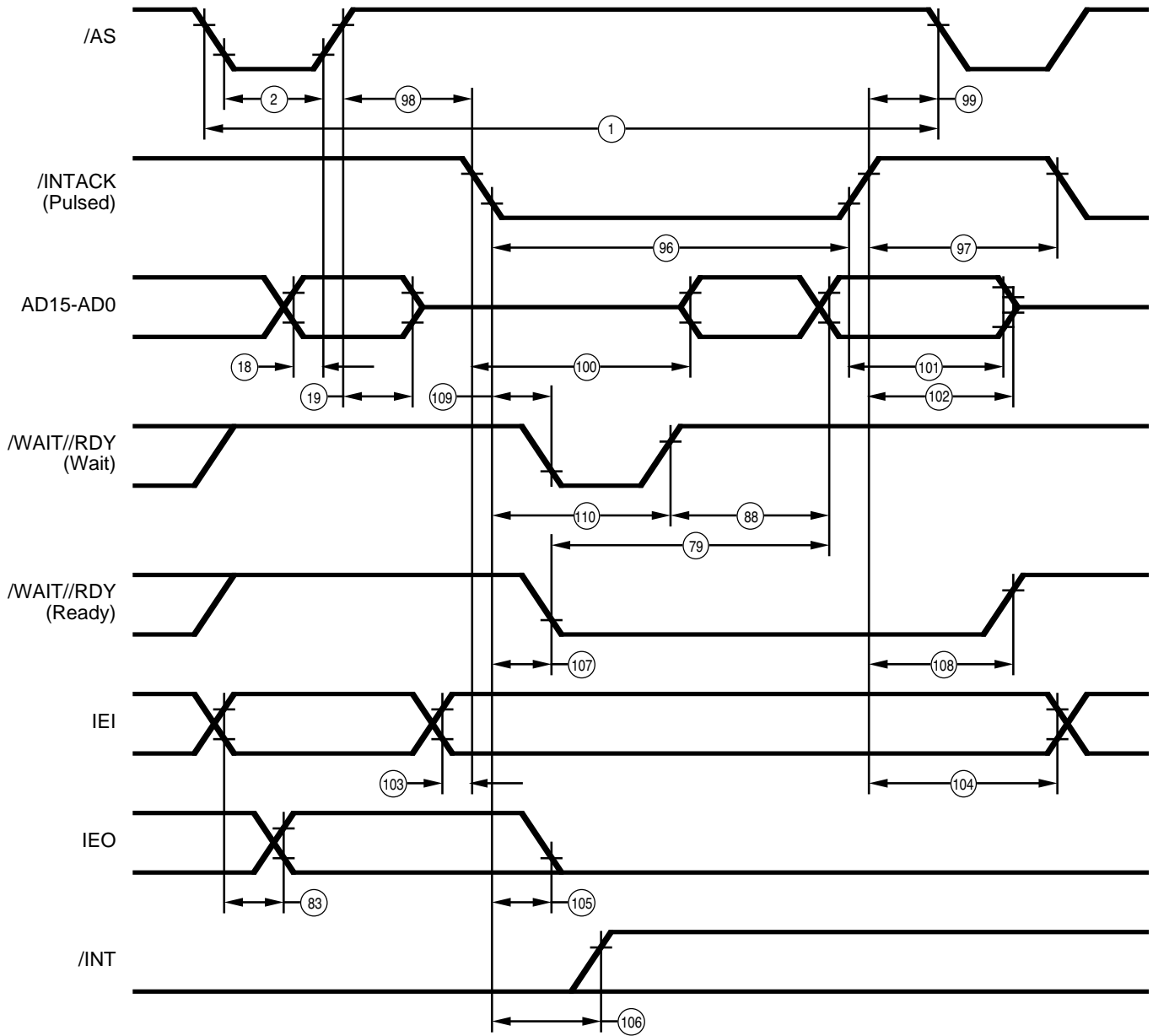

Figure 95. Multiplexed Pulsed Interrupt Acknowledge Cycle

AC CHARACTERISTICS

Timing Diagrams (Continued)

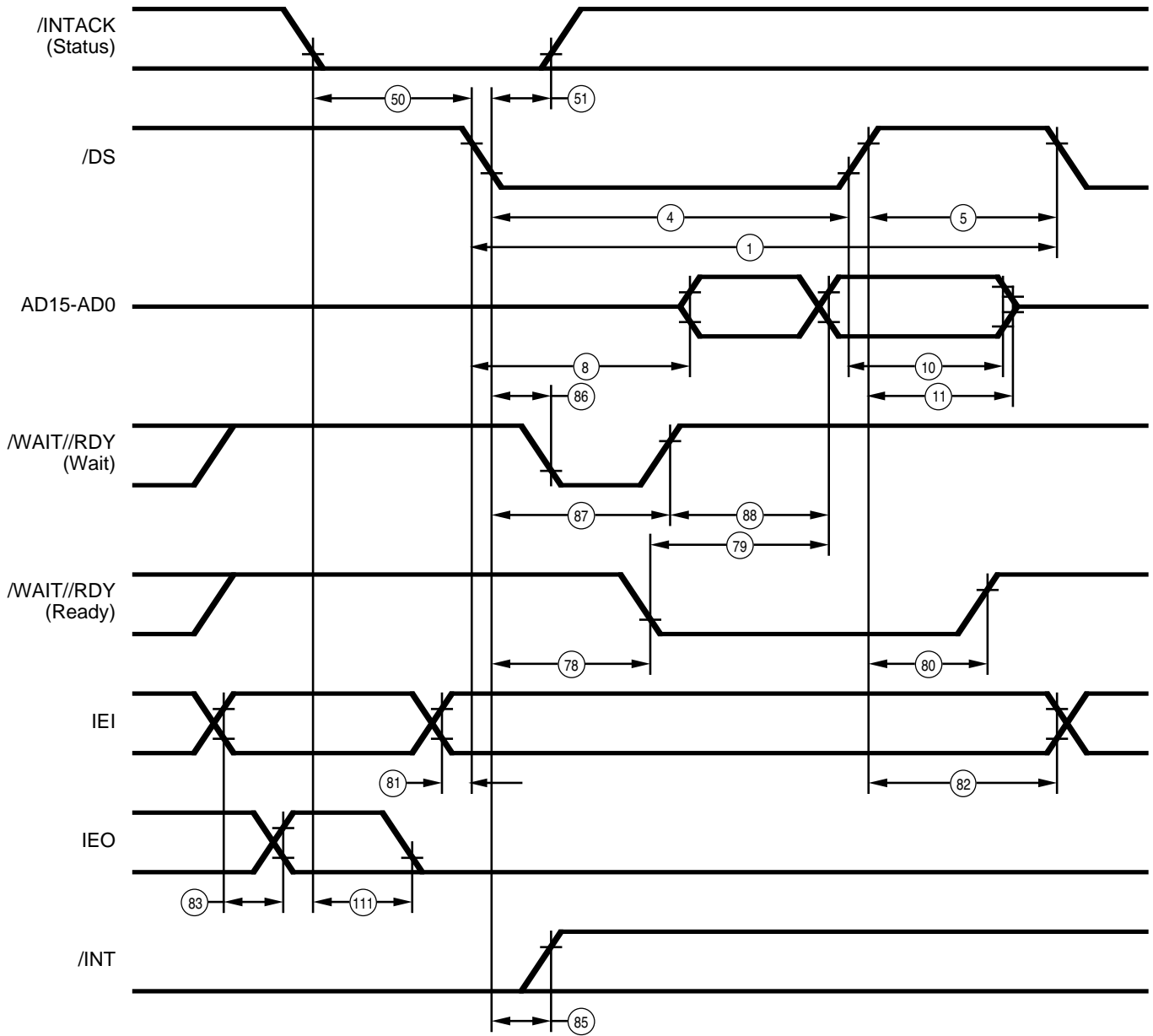

Figure 96. Non-Multiplexed /DS Interrupt Acknowledge Cycle

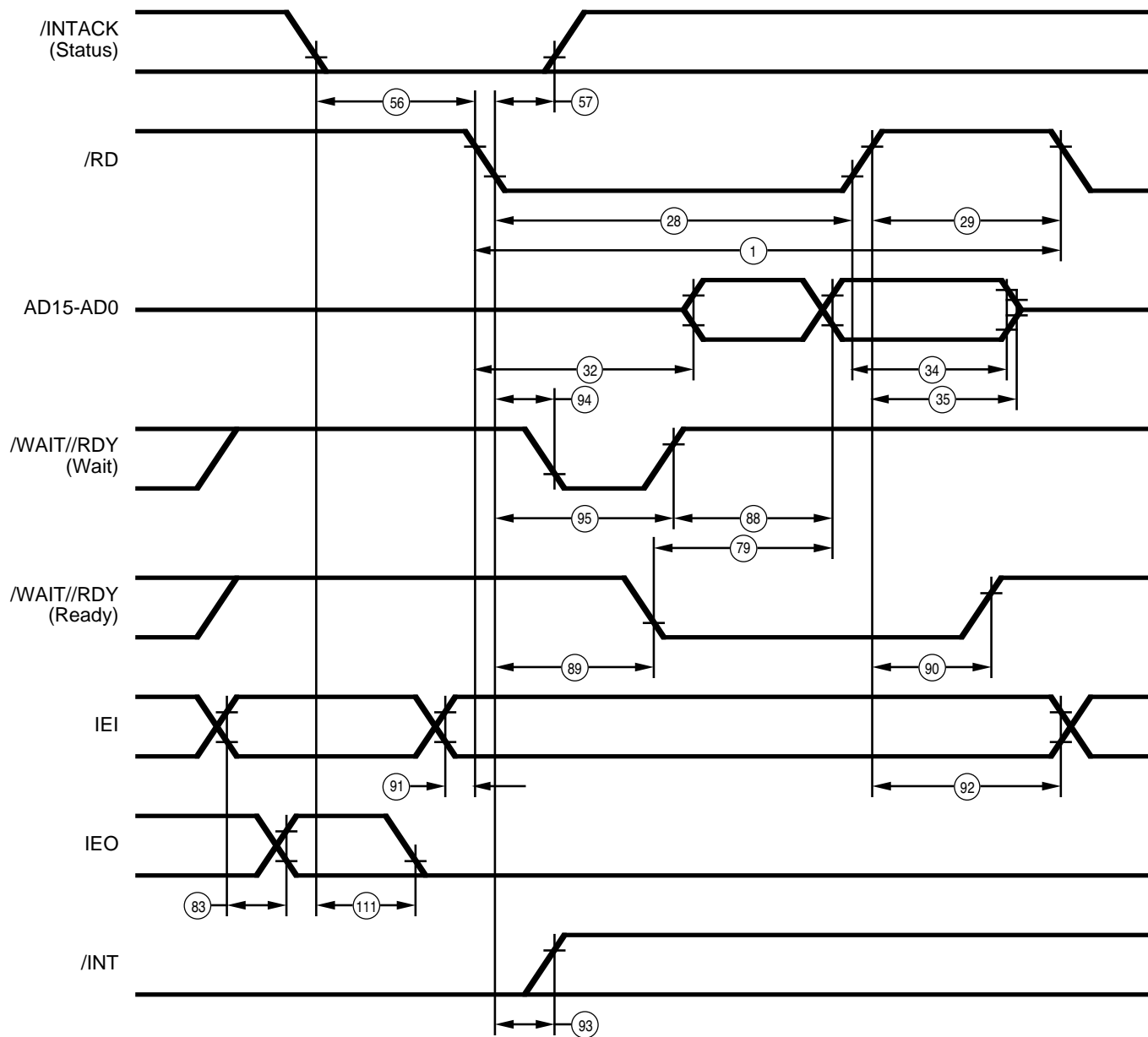

Figure 97. Non-Multiplexed /RD Pulsed Interrupt Acknowledge Cycle

AC CHARACTERISTICS

Timing Diagrams (Continued)

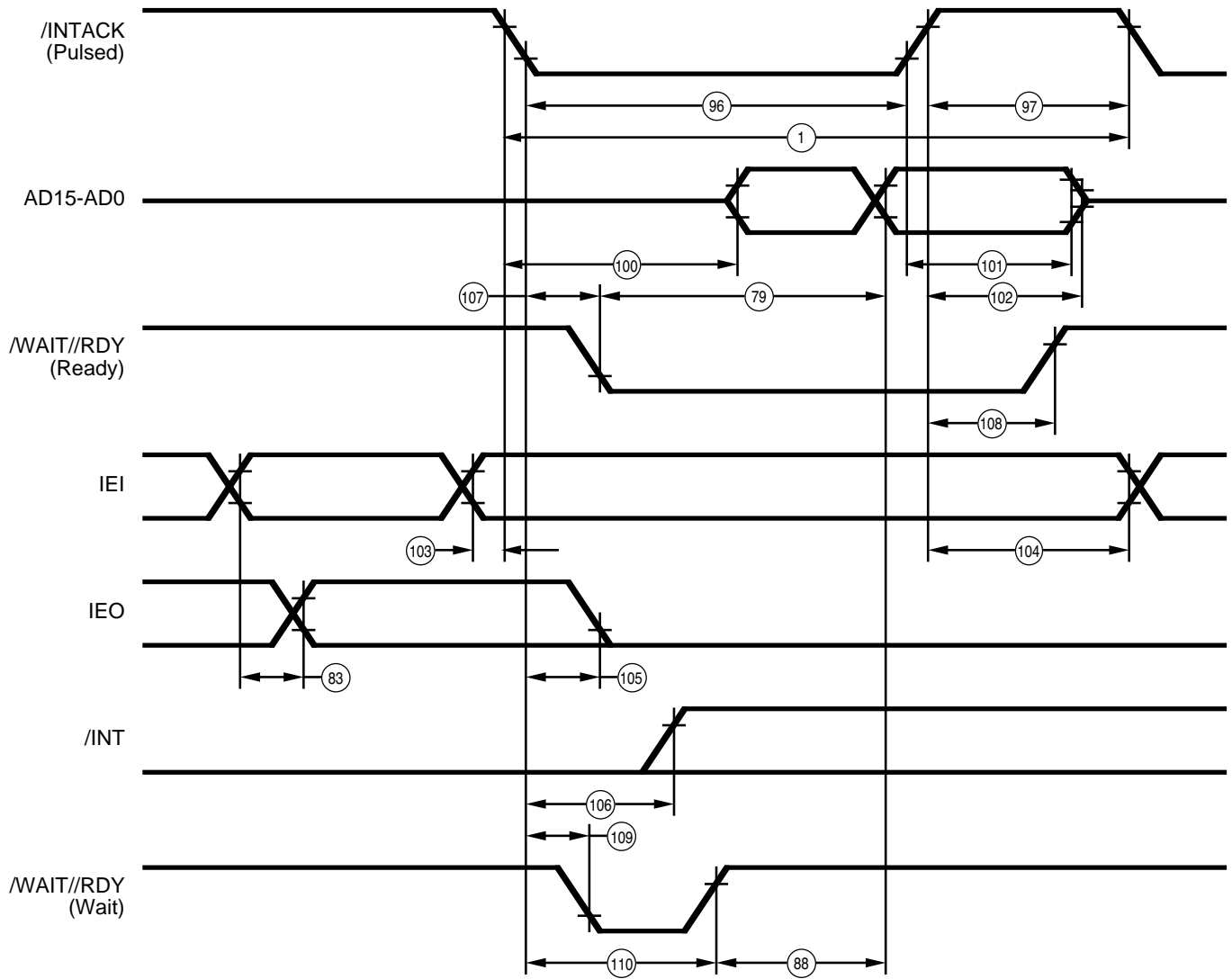

Figure 98. Non-Multiplexed Pulsed Interrupt Acknowledge Cycle

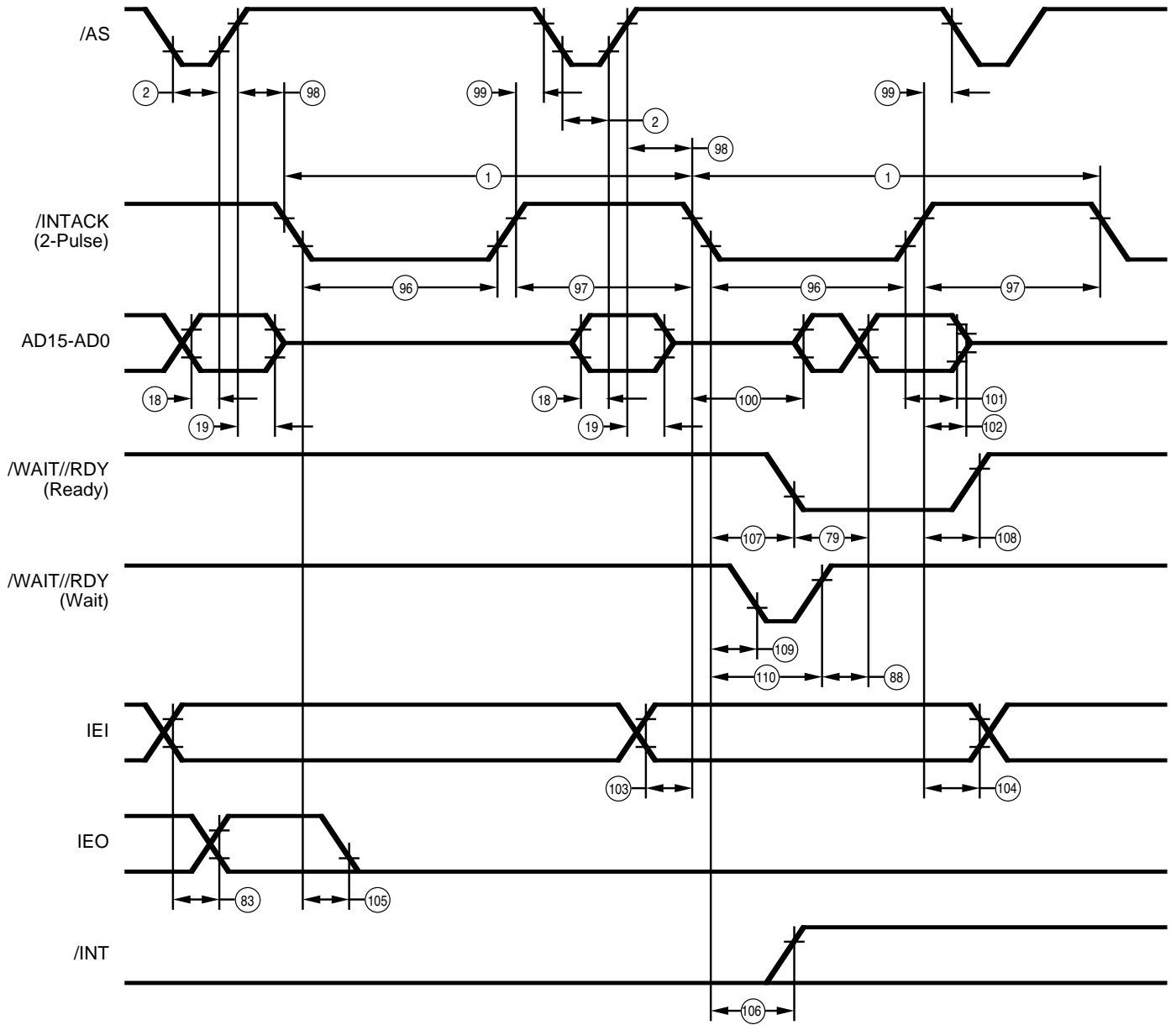

Figure 99. Multiplexed Double-Pulse Intack Cycle

AC CHARACTERISTICS

Timing Diagrams (Continued)

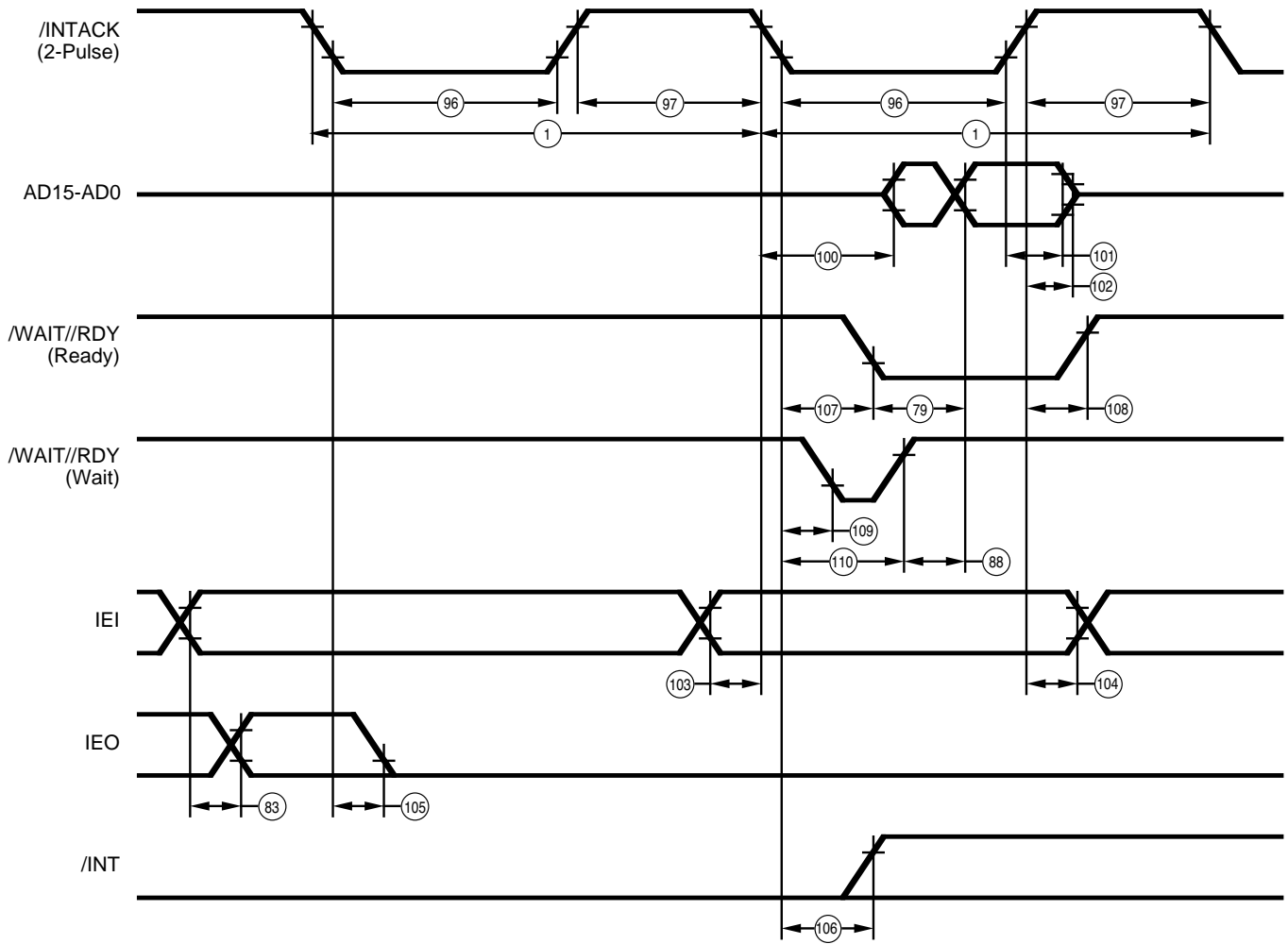

Figure 100. Non-Multiplexed Double-Pulse Intack Cycle

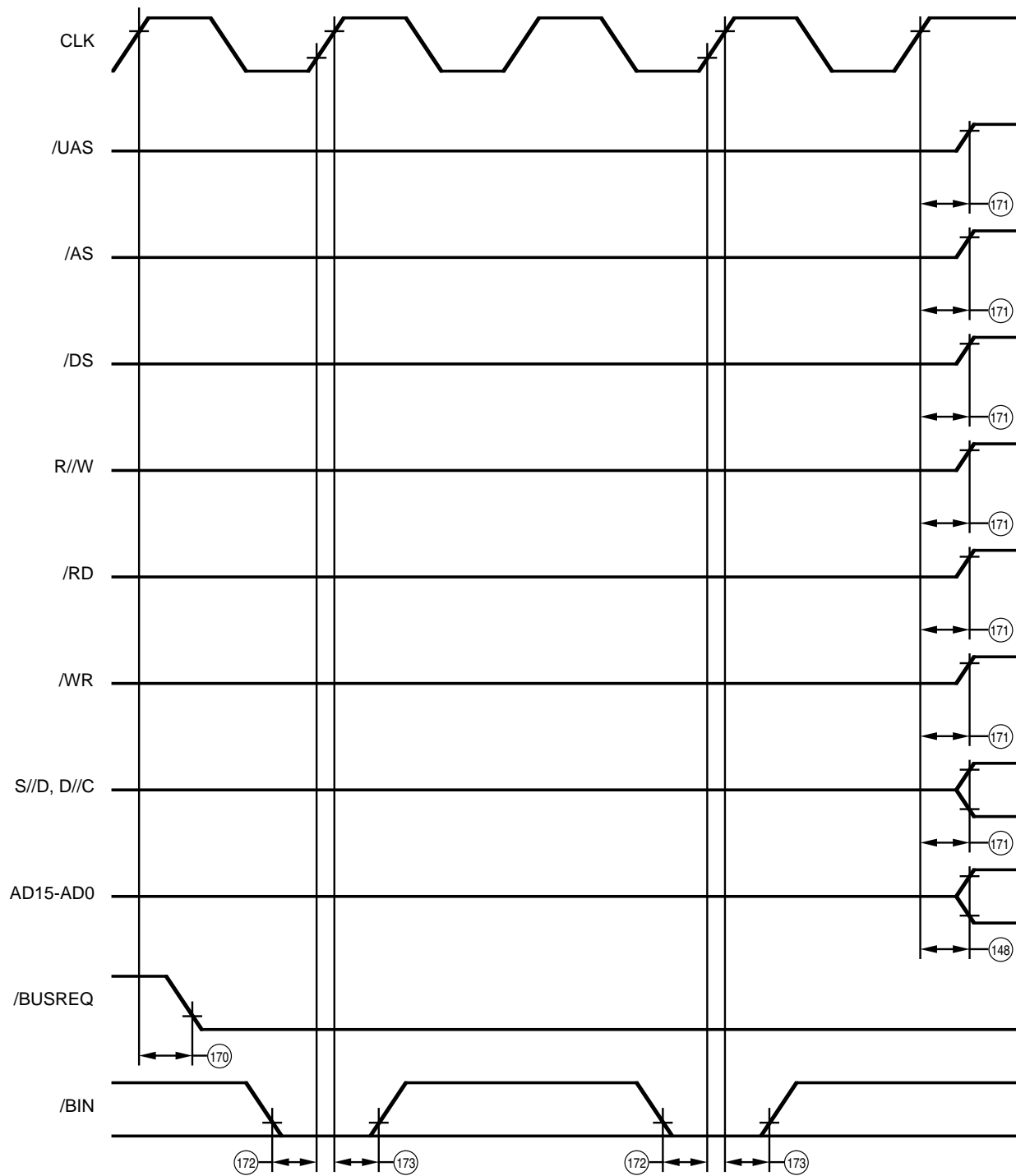

Figure 101. DMA Start-Up

AC CHARACTERISTICS

Timing Diagrams (Continued)

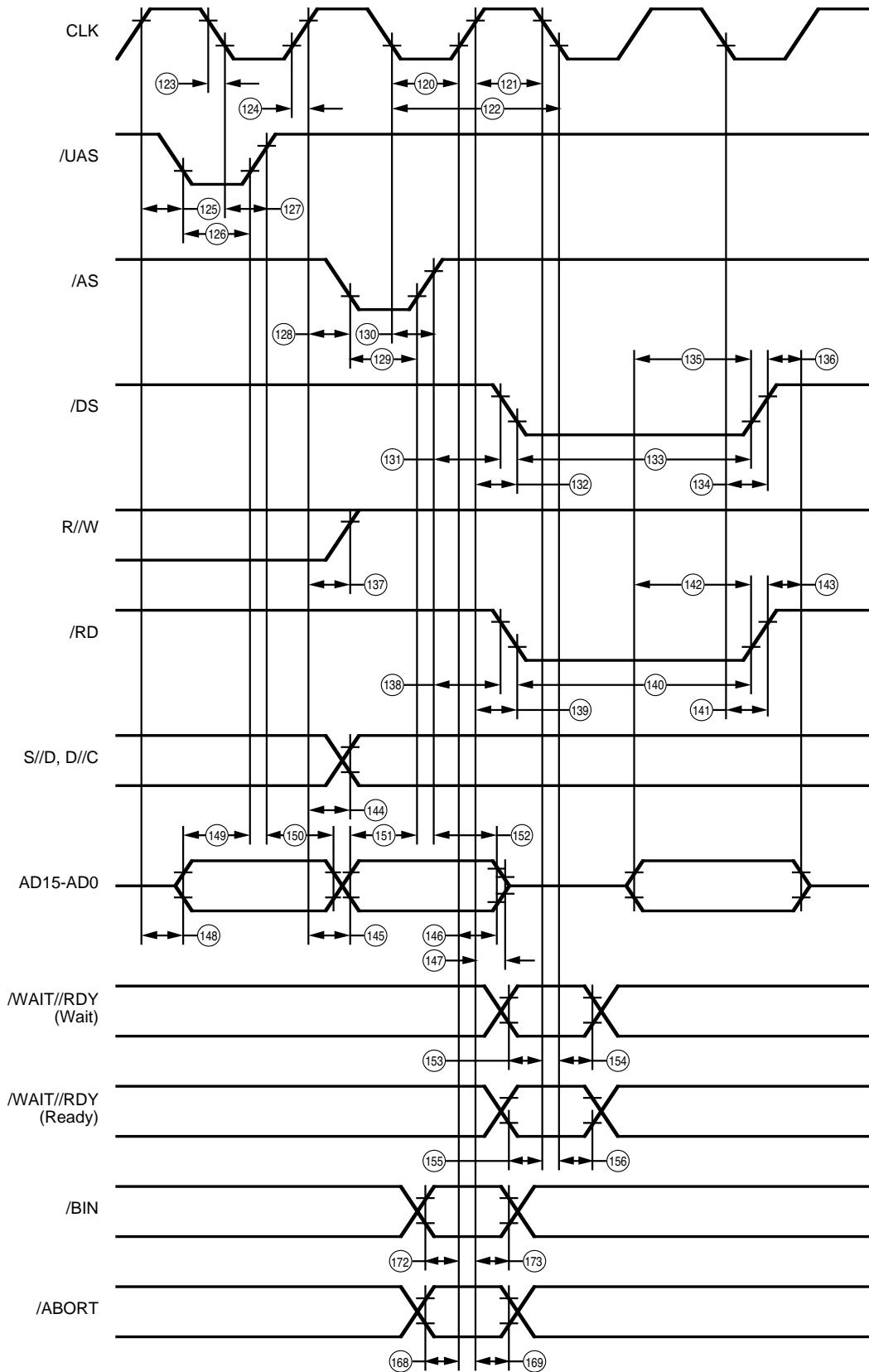

Figure 102. Memory Read

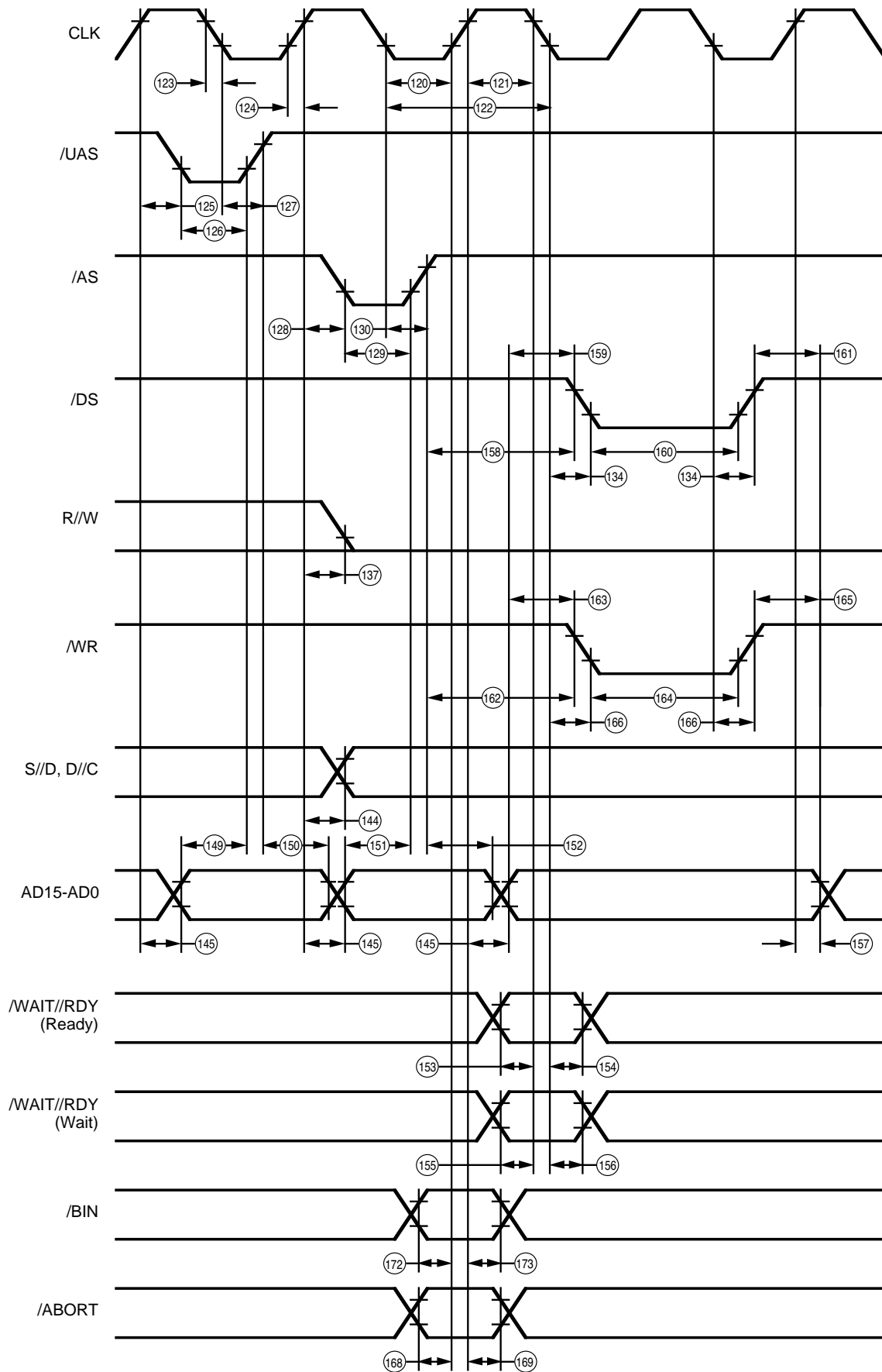

Figure 103. Memory Write

AC CHARACTERISTICS

Timing Diagrams (Continued)

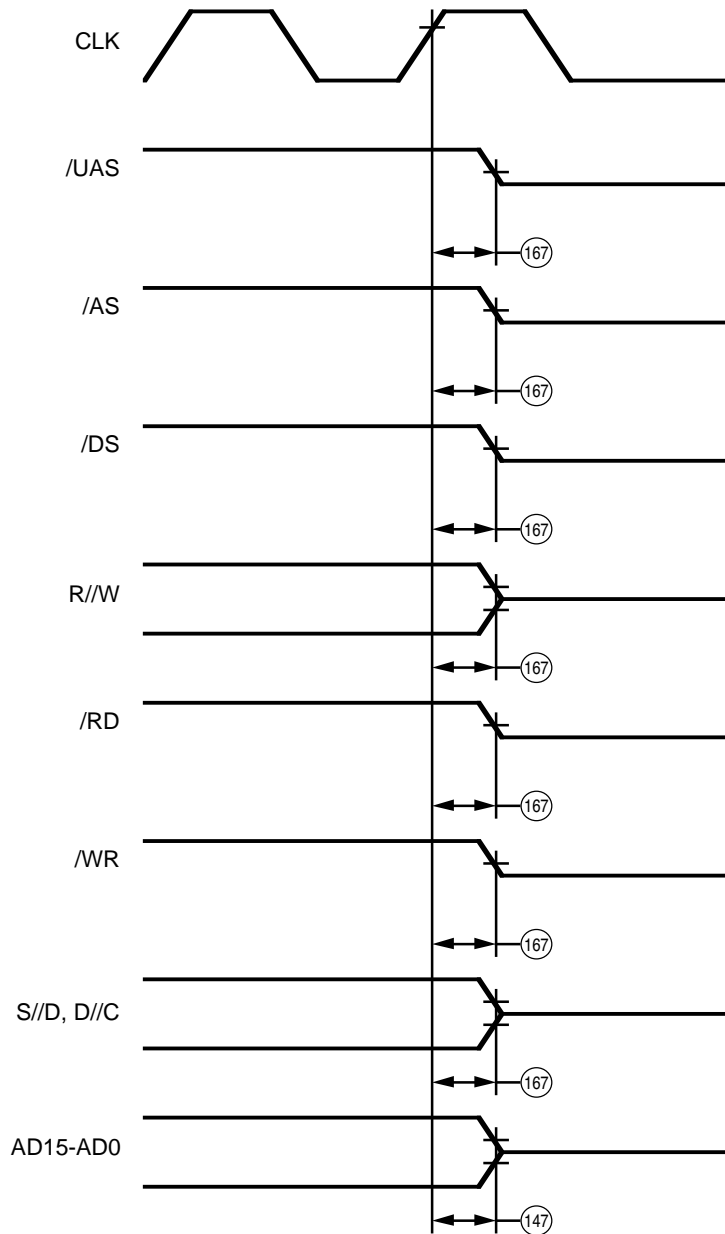

Figure 104. Bus Release

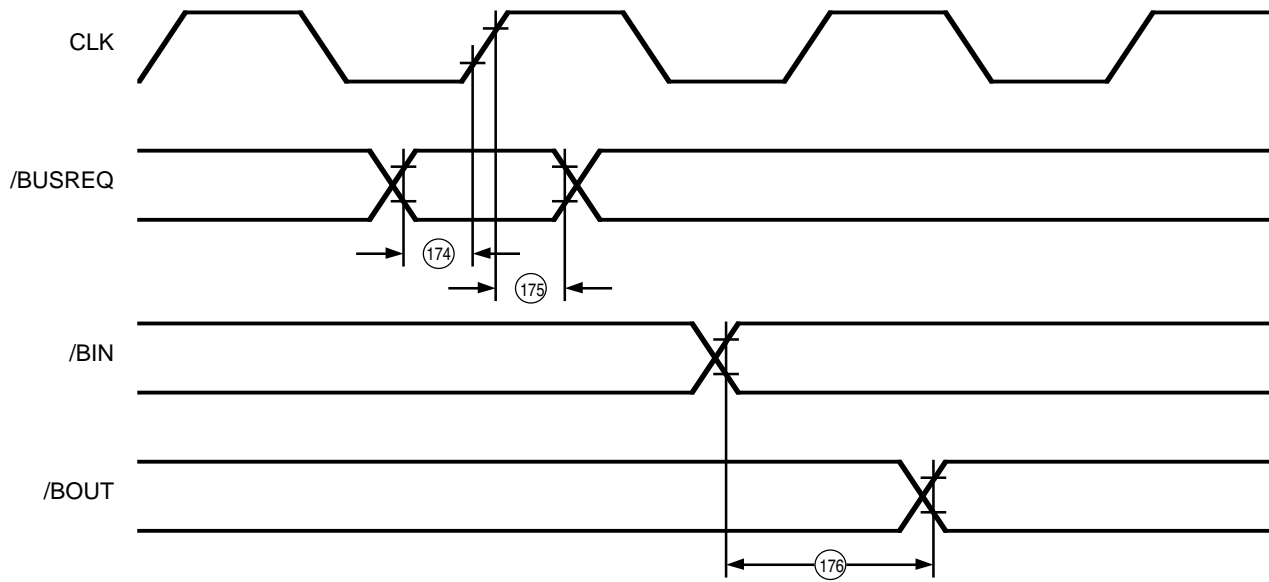

Figure 105. Request Timing

AC CHARACTERISTICS

Timing Table

No	Symbol	Parameter	Min	Max	Units	Note
1	Tcyc	Bus Cycle Time	160		ns	
2	TwASI	/AS Low Width	40		ns	
3	TwASh	/AS High Width	90		ns	
4	TwDSI	/DS Low Width	70		ns	
5	TwDSh	/DS High Width	60		ns	
6	TdAS(DS)	/AS Rise to /DS Fall Delay Time	5		ns	
7	TdDS(AS)	/DS Rise to /AS Fall Delay Time	5		ns	
8	TdDS(DRa)	/DS Fall to Data Active Delay	0		ns	
9	TdDS(DRv)	/DS Fall to Data Valid Delay		85	ns	
10	TdDS(DRn)	/DS Rise to Data Not Valid Delay	0		ns	
11	TdDS(DRz)	/DS Rise to Data Float Delay		20	ns	
12	TsCS(AS)	/CS to /AS Rise Setup Time	15		ns	
13	ThCS(AS)	/CS to /AS Rise Hold Time	5		ns	
14	TsADD(AS)	Direct Address to /AS Rise Setup Time	15		ns	[1]
15	ThADD(AS)	Direct Address to /AS Rise Hold Time	5		ns	[1]
16	TsSIA(AS)	Status /INTACK to /AS Rise Setup Time	15		ns	
17	ThSIA(AS)	Status /INTACK to /AS Rise Hold Time	5		ns	
18	TsAD(AS)	Address to /AS Rise Setup Time	15		ns	
19	ThAD(AS)	Address to /AS Rise Hold Time	5		ns	
20	TsRW(DS)	R//W to /DS Fall Setup Time	0		ns	
21	ThRW(DS)	R//W to /DS Fall Hold Time	25		ns	
22	TsDSf(RRQ)	/DS Fall to /RxREQ Inactive Delay		60	ns	[4]
23	TdDSr(RRQ)	/DS Rise to /RxREQ Active Delay	0		ns	
24	TsDW(DS)	Write Data to /DS Rise Setup Time	30		ns	
25	ThDW(DS)	Write Data to DS Rise Hold Time	0		ns	
26	TdDSf(TRQ)	/DS Fall to /TxREQ Inactive Delay		60	ns	[5]
27	TdDSr(TRQ)	/DS Rise to /TxREQ Active Delay	0		ns	
28	TwRDI	/RD Low Width	70		ns	
29	TwRDh	/RD High Width	60		ns	
30	TdAS(RD)	/AS Rise to /RD Fall Delay Time	5		ns	
31	TdRD(AS)	/RD Rise to /AS Fall Delay Time	5		ns	
32	TdRD(DRa)	/RD Fall to Data Active Delay	0		ns	
33	TdRD(DRv)	/RD Fall to Data Valid Delay		85	ns	
34	TdRD(DRn)	/RD Rise to Data Not Valid Delay	0		ns	
35	TdRD(DRz)	/RD Rise to Data Float Delay		20	ns	
36	TdRDf(RRQ)	/RD Fall to /RxREQ Inactive Delay		60	ns	[4]
37	TdRDr(RRQ)	/RD Rise to /RxREQ Active Delay	0		ns	
38	TwWRI	/WR Low Width	70		ns	
39	TwWRh	/WR High Width	60		ns	
40	TdAS(WR)	/AS Rise to /WR Fall Delay Time	5		ns	
41	TdWR(AS)	/WR Rise to /AS Fall Delay Time	5		ns	
42	TsDW(WR)	Write Data to /WR Rise Setup Time	30		ns	
43	ThDW(WR)	Write Data to /WR Rise Hold Time	0		ns	
44	TdWRf(TRQ)	/WR Fall to /TxREQ Inactive Delay		60	ns	[5]

No	Symbol	Parameter	Min	Max	Units	Note
45	TdWRr(TRQ)	/WR Rise to /TxREQ Active Delay	0		ns	
46	TsCS(DS)	/CS to /DS Fall Setup Time	0		ns	[2]
47	ThCS(DS)	/CS to /DS Fall Hold Time	25		ns	[2]
48	TsADD(DS)	Direct Address to /DS Fall Setup Time	5		ns	[1,2]
49	ThADD(DS)	Direct Address to /DS Fall Hold Time	25		ns	[1,2]
50	TsSIA(DS)	Status /INTACK to /DS Fall Setup time	5		ns	[2]
51	ThSIA(DS)	Status /INTACK to /DS Fall Hold Time	25		ns	[2]
52	TsCS(RD)	/CS to /RD Fall Setup Time	0		ns	[2]
53	ThCS(RD)	/CS to /RD Fall Hold Time	25		ns	[2]
54	TsADD(RD)	Direct Address to /RD Fall Setup Time	5		ns	[1,2]
55	ThADD(RD)	Direct Address to /RD Fall Hold Time	25		ns	[1,2]
56	TsSIA(RD)	Status /INTACK to /RD Fall Setup Time	5		ns	[2]
57	ThSIA(RD)	Status /INTACK to /RD Fall Hold Time	25		ns	[2]
58	TsCS(WR)	/CS to /WR Fall Setup Time	0		ns	[2]
59	ThCS(WR)	/CS to /WR Fall Hold Time	25		ns	[2]
60	TsADD(WR)	Direct Address to /WR Fall Setup Time	5		ns	[1,2]
61	ThADD(WR)	Direct Address to /WR Fall Hold Time	25		ns	[1,2]
62	TsSIA(WR)	Status /INTACK to /WR Fall Setup Time	5		ns	[2]
63	ThSIA(WR)	Status /INTACK to /WR Fall Hold Time	25		ns	[2]
78	TdDSf(RDY)	/DS Fall (Intack) to /RDY Fall Delay		200	ns	
79	TdRDY(DRv)	/RDY Fall to Data Valid Delay		40	ns	
80	TdDSr(RDY)	/DS Rise to /RDY Rise Delay		40	ns	
81	TsIEI(DSI)	IEI to /DS Fall (Intack) Setup Time	60		ns	
82	ThIEI(DSI)	IEI to /DS Rise (Intack) Hold Time	0		ns	
83	TdIEI(IEO)	IEI to IEO Delay		60	ns	
84	TdAS(IEO)	/AS Rise (Intack) to IEO Delay		60	ns	
85	TdDSI(INT)	/DS Fall to /INT Inactive Delay		200	ns	
86	TdDSI(Wf)	/DS Fall (Intack) to /WAIT Fall Delay		40	ns	
87	TdDSI(Wr)	/DS Fall (Intack) to /WAIT Rise Delay		200	ns	
88	TdW(DRv)	/WAIT Rise to Data Valid Delay		40	ns	
89	TdRDf(RDY)	/RD Fall (Intack) to /RDY Fall Delay		200	ns	
90	TdRDr(RDY)	/RD Rise to /RDY Rise Delay		40	ns	
91	TsIEI(RDI)	IEI to /RD Fall (Intack) Setup Time	60		ns	
92	ThIEI(RDI)	IEI to /RD Rise (Intack) Hold Time	0		ns	
93	TdRDI(INT)	/RD Fall (Intack) to /INT Inactive Delay		200	ns	
94	TdRDI(Wf)	/RD Fall (Intack) to /WAIT Fall Delay		40	ns	
95	TdRDI(Wr)	/RD Fall (Intack) to /WAIT Rise Delay		200	ns	
96	TwPIAI	Pulsed /INTACK Low Width	70		ns	
97	TwPIAh	Pulsed /INTACK High Width	60		ns	
98	TdAS(PIA)	/AS Rise to Pulsed /INTACK Fall Delay Time	5		ns	
99	TdPIA(AS)	Pulsed /INTACK Rise to /AS Fall Delay Time	5		ns	
100	TdPIA(DRa)	Pulsed /INTACK Fall to Data Active Delay	0		ns	
101	TdPIA(DRn)	Pulsed /INTACK Rise to Data Not Valid Delay	0		ns	
102	TdPIA(DRz)	Pulsed /INTACK Rise to Data Float Delay		20	ns	

AC CHARACTERISTICS (Continued)

Timing Table

No	Symbol	Parameter	Min	Max	Units	Note
103	TsIEI(PIA)	IEI to Pulsed /INTACK Fall Setup Time	10		ns	
104	ThIEI(PIA)	IEI to Pulsed /INTACK Rise Hold Time	0		ns	
105	TdPIA(IEO)	Pulsed /INTACK Fall to IEO Delay		60	ns	
106	TdPIA(INT)	Pulsed /INTACK Fall to /INT Inactive Delay		200	ns	
107	TdPIAf(RDY)	Pulsed /INTACK Fall to /RDY Fall Delay		200	ns	
108	TdPIAr(RDY)	Pulsed /INTACK Rise to /RDY Rise Delay		40	ns	
109	TdPIA(Wf)	Pulsed /INTACK Fall to /WAIT Fall Delay		40	ns	
110	TdPIA(Wr)	Pulsed /INTACK Fall to /WAIT Rise Delay		200	ns	
111	TdSIA(INT)	Status /INTACK Fall to IEO Inactive Delay		200	ns	[2]
112	TwSTBh	/Strobe High Width	50		ns	[3]
113	TwRESl	/RESET Low Width	170		ns	
114	TwRESH	/RESET High Width	60		ns	
115	TdRES(STB)	/RESET Rise to /STB Fall	60		ns	[3]
116	TdDSf(RDY)	/DS Fall to /RDY Fall Delay		50	ns	
117	TdWRf(RDY)	/WR Fall to /RDY Fall Delay		50	ns	
118	TdWRr(RDY)	/WR Rise to /RDY Rise Delay		40	ns	
119	TdRdf(RDY)	/RD Fall to /RDY Fall Delay		50	ns	
120	TwCLKl	CLK Low Width	25		ns	
121a	TwCLKh	CLK High Width	25		ns	
121b	TwCLKh	CLK High Width (Linked List Mode)	35		ns	[12]
122a	TcCLK	CLK Cycle Time	50		ns	
122b	TcCLK	CLK Cycle Time (Linked List Mode)	60		ns	[12]
123	TfCLK	CLK Fall Time		5	ns	
124	TrCLK	CLK Rise Time		5	ns	
125	TdCLKr (UAS)	CLK Rise to /UAS Fall Delay		30	ns	[6]
126	TwUASl	/UAS Low Width	25		ns	[6,7,13]
127	TdCLKf(UAS)	CLK Fall to /UAS Rise Delay		30	ns	[6]
128	TdCLKr(AS)	CLK Rise to /AS Fall Delay		30	ns	[6]
129	TwASl	/AS Low Width	25		ns	[6,7,13]
130	TdCLKf(AS)	CLK Fall to /AS Rise Delay		30	ns	[6]
131	TdAS(DSr)	/AS Rise to /DS Fall (Read) Delay	25		ns	[6,8]
132	TdCLKr(DS)	CLK Rise to /DS Delay		30	ns	[6]
133	TwDSl	/DS (Read) Low Width	75		ns	[6,9,13]
134	TdCLKf(DS)	CLK Fall to /DS Delay		30	ns	[6]
135	TsDR(DS)	Read Data to /DS Rise Setup Time	30		ns	[6]
136	ThDR(DS)	Read Data to /DS Rise Hold Time	0		ns	[6]
137	TdCLK(RW)	CLK Rise to R/W Delay		30	ns	[6]
138	TdAS(RD)	/AS Rise to /RD Fall Delay	25		ns	[6,8]
139	TdCLKr(RD)	CLK Rise to /RD Delay		30	ns	[6]
140	TwRDI	/RD Low Width	75		ns	[6,9]
141	TdCLKf(RD)	CLK Fall to /RD Delay		30	ns	[6]
142	TsDR(RD)	Read Data to /RD Rise Setup Time	30		ns	[6]
143	ThDR(RD)	Read Data to /RD Rise Hold Time	0		ns	[6]
144	TdCLK(ADD)	CLK Rise to Direct Address Delay		30	ns	[1,6]
145	TdCLK(AD)	CLK Rise to Address Delay	TdCLKf(DS)	35	ns	[6]
146	ThAD(PC)	Address to CLK Rise Hold Time	0		ns	[6]

No	Symbol	Parameter	Min	Max	Units	Note
147	TdCLK(ADz)	CLK Rise to Address Float Delay		35	ns	[6]
148	TdCLK(ADa)	CLK Rise to Address Active Delay		35	ns	[6]
149	TsAD(UAS)	Address to /UAS Rise Setup Time	10		ns	[6]
150	ThAD(UAS)	Address to /UAS Rise Hold Time	10		ns	[6]
151	TsAD(AS)	Address to /AS Rise Setup Time	10		ns	[6]
152	ThAD(AS)	Address to /AS Rise Hold Time	10		ns	[6]
153	TsW(CLK)	/WAIT to CLK Fall Setup Time	10		ns	[6]
154	ThW(CLK)	/WAIT to CLK Fall Hold Time	15		ns	[6]
155	TsRDY(CLK)	/READY to CLK Fall Setup Time	10		ns	[6]
156	ThRDY(CLK)	/READY to CLK Fall Hold Time	15		ns	[6]
157	ThDW(CLK)	Write Data to CLK Rise Hold Time	0		ns	[6]
158	TdAS(DSw)	/AS Rise to /DS Fall (Write) Delay	40		ns	[6,10,13]
159	TsDW(DS)	Write Data to /DS Fall Setup Time	25		ns	[6,7,13]
160	TwDSlw	/DS (Write) Low Width	45		ns	[6,11,13]
161	ThDW(DS)	Write Data to /DS Rise Hold Time	25		ns	[6,8]
162	TdAS(WR)	/AS Rise to /WR Fall Delay	40		ns	[6,10,13]
163	TsDW(WR)	Write Data to /WR Fall Setup Time	25		ns	[6,7,13]
164	TwWRI	/WR Low Width	45		ns	[6,11,13]
165	ThDW(WR)	Write Data to /WR Rise Hold Time	25		ns	[6,8]
166	TdCLK(WR)	CLK Fall to /WR Delay		30	ns	[6]
167	TdCLK(BUSz)	CLK Rise to Bus Float Delay		30	ns	[6]
168	TsABT(CLK)	/ABORT to CLK Rise Setup Time	20		ns	[6]
169	ThABT(CLK)	/ABORT to CLK Rise Hold Time	15		ns	[6]
170	TdCLK(BRQ)	CLK Rise to /BUSREQ Delay		30	ns	[6]
171	TdCLK(BUSa)	CLK Rise to Bus Active Delay		30	ns	[6]
172	TsBIN(CLK)	/BIN to CLK Rise Setup Time	20		ns	[6]
173	ThBIN(CLK)	/BIN to CLK Rise Hold Time	15		ns	[6]
174	TsBRQ(CLK)	/BUSREQ to CLK Rise Setup Time	25		ns	[6]
175	ThBRQ(CLK)	/BUSREQ to CLK Rise Hold Time	0		ns	[6]
176	TdBIN(BOT)	/BIN to /BOUT Delay		60	ns	

Notes:**AC Test Conditions:**

$V_{CC} = 5V \pm 5\%$ unless otherwise specified,
over specified temperature range.

$V_{IH} = 2.0V$ $V_{OH} = 2.0V$

$V_{IL} = 0.8V$ $V_{OL} = 0.8V$

Float = +0.5V

- [1] Direct Address is any of S//D, D//C or AD15-AD8 used as an address bus.
 [2] The parameter applies only when /AS is not present.
 [3] Strobe is any of /DS, /RD, /WR or Pulsed /INTACK.
 [4] Parameter applies only if read empties the receive FIFO.
 [5] Parameter applies only if write fills the transmit FIFO.
 [6] Parameter applies only while the IUSC is bus master.

[7] Parameter is clock-cycle dependent, $TwCLKh + TfCLK - 5$.

[8] Parameter is clock-cycle dependent, $TwCLKI + TrCLK - 5$

[9] Parameter is clock-cycle dependent,
 $TcCLK + TwCLKh + TfCLK - 5$.

[10] Parameter is clock-cycle dependent, $TcCLK - 10$.

[11] Parameter is clock-cycle dependent, $TcCLK - 5$.

[12] Clock cycle parameters $TwCLKh$ and $TcCLK$ have unique values for Linked List Mode. In Linked List Mode, the system clock cycle is extended to 60 ns, and the system clock High pulse width is extended to 35 ns. This is due to the internal timing paths unique to the Linked List Mode. The transmit and receive bit rates are not affected.

[13] For Linked List Mode, the minimum for these values should be calculated using $TwCLKh = 35$ ns and $TcCLK = 60$ ns.

AC CHARACTERISTICS

General Timing Diagram

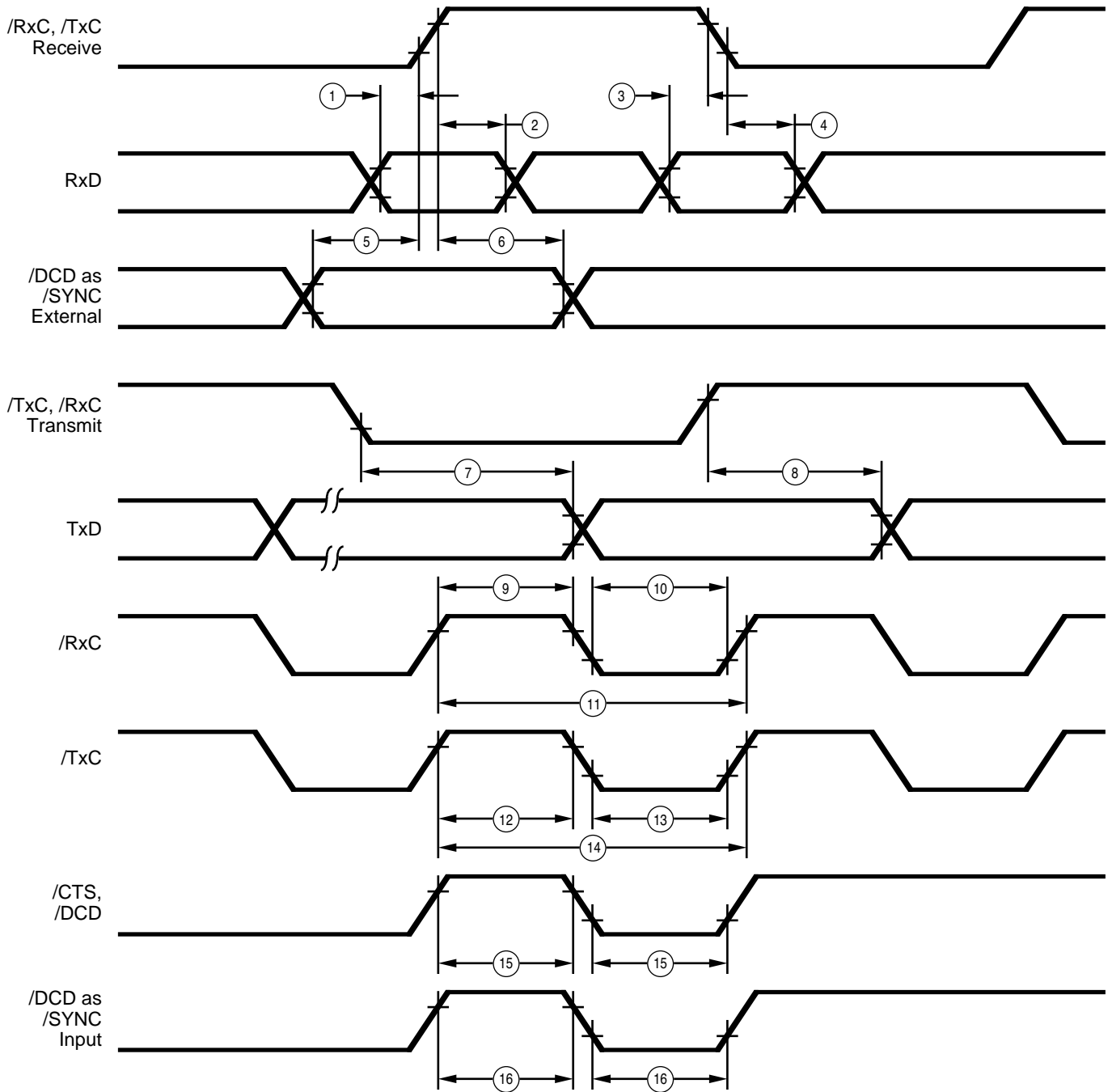

Figure 106. General Timing

AC CHARACTERISTICS

General Timing Table

No	Symbol	Parameter	Min	Max	Units	Note
1	TsRxD(RxCr)	RxD to /RxC Rise Setup Time (x1 Mode)	0		ns	[1]
2	ThRxD(RxCr)	RxD to /RxC Rise Hold Time (x1 Mode)	20		ns	[1]
3	TsRxD(RxCf)	RxD to /RxC Fall Setup Time (x1 Mode)	0		ns	[1,3]
4	ThRxD(RxCf)	RxD to /RxC Fall Hold Time (x1 Mode)	20		ns	[1,3]
5	TsSy(RxC)	/DCD as /SYNC to /RxC Rise Setup Time	0		ns	[1]
6	ThSy(RxC)	/DCD as /SYNC to /RxC Rise Hold Time (x1 Mode)	20		ns	[1]
7	TdTxCr(TxD)	/TxC Fall to TxD Delay		25	ns	[2]
8	TdTxCr(TxD)	/TxC Rise to TxD Delay		25	ns	[2,3]
9	TwRxCh	/RxC High Width	20		ns	
10	TwRxCl	/RxC Low Width	20		ns	
11	TcRxC	/RxC Cycle Time	50		ns	
12	TwTxCh	/TxC High Width	20		ns	
13	TwTxCl	/TxC Low Width	20		ns	
14	TcTxC	/TxC Cycle Time	50		ns	
15	TwExT	/DCD or /CTS Pulse Width	35		ns	
16	TWSY	/DCD as /SYNC Input Pulse Width	35		ns	

AC CHARACTERISTICS

System Timing Diagram

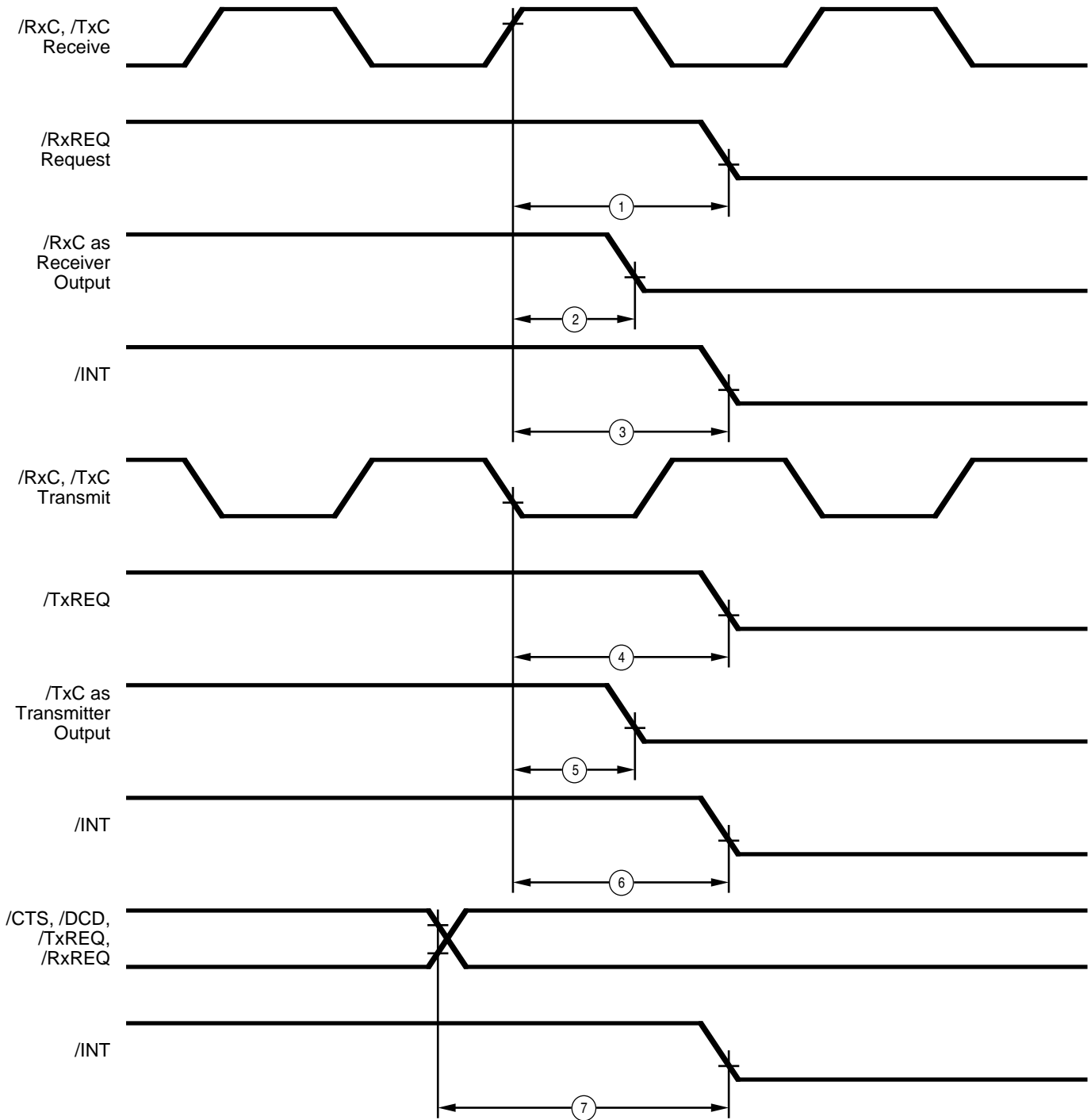

Figure 107. Z16C32 System Timing

AC CHARACTERISTICS

System Timing Table

No	Symbol	Parameter	Min	Max	Units	Note
1	TdRxC(REQ)	/RxC Rise to /RxREQ Valid Delay		50	ns	[2]
2	TdRxC(RxC)	/TxC Rise to /RxC as Receiver Output Valid Delay		50	ns	[2]
3	TdRxC(INT)	/RxC Rise to /INT Valid Delay		50	ns	[2]
4	TdTxC(REQ)	/TxC Fall to /TxREQ Valid Delay		50	ns	[2]
5	TdTxC(TxC)	/RxC Fall to /TxC as transmitter Output Valid Delay		50	ns	
6	TdTxC(INT)	/TxC Fall to /INT Valid Delay		50	ns	[2]
7	TdEXT(INT)	/CTS, /DCD, /TxREQ, /RxREQ transition to /INT Valid Delay		50	ns	

Notes:

[1] /RxC is /RxC or /TxC, whichever is supplying the receive clock.

[2] /TxC is /TxC or /RxC, whichever is supplying the transmit clock.

[3] Parameter applies only to FM encoding/decoding.

PACKAGE INFORMATION

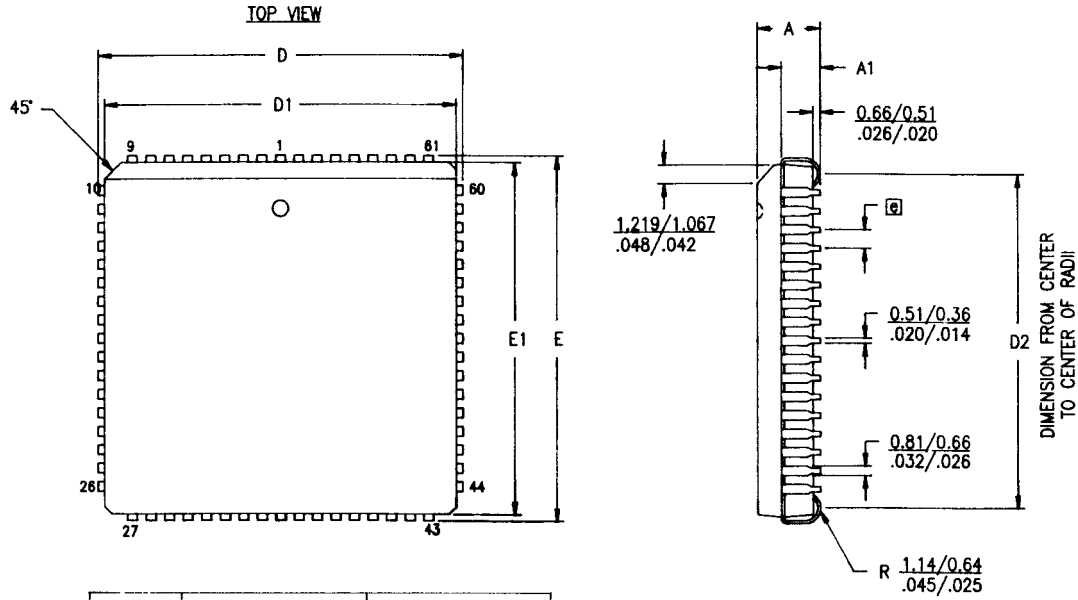

SYMBOL	MILLIMETER		INCH	
	MIN	MAX	MIN	MAX
A	4.32	4.57	.170	.180
A1	2.43	2.92	.095	.115
D/E	25.02	25.40	.985	1.000
D1/E1	24.13	24.33	.950	.958
D2	22.86	23.62	.900	.930
⊠	1.27 TYP		.050 TYP	

NOTES:

1. CONTROLLING DIMENSIONS : INCH
2. LEADS ARE COPLANAR WITHIN .004 IN RANGE.
3. DIMENSION : $\frac{\text{MM}}{\text{INCH}}$

68-Pin PLCC Package Diagram

ORDERING INFORMATION**Z16C32 IUSC****20 MHz****68-Pin PLCC**

Z16C3220VSC

For fast results, contact your local ZiLog sales office for assistance in ordering the part desired.

Package

V = Plastic Chip Carrier

Temperature

S = 0°C to 70°C

Speed

20 = 20 MHz

Environmental

C = Plastic Standard

Example:

Z 16C32 20 V S C is a Z16C32, 20 MHz, PLCC, 0°C to +70°C, Plastic Standard Flow

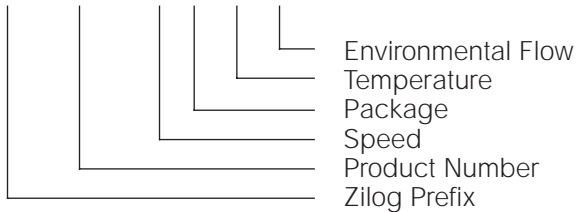

© 1997 by ZiLog, Inc. All rights reserved. No part of this document may be copied or reproduced in any form or by any means without the prior written consent of ZiLog, Inc. The information in this document is subject to change without notice. Devices sold by ZiLog, Inc. are covered by warranty and patent indemnification provisions appearing in ZiLog, Inc. Terms and Conditions of Sale only. ZiLog, Inc. makes no warranty, express, statutory, implied or by description, regarding the information set forth herein or regarding the freedom of the described devices from intellectual property infringement. ZiLog, Inc. makes no warranty of merchantability or fitness for any purpose. ZiLog, Inc. shall not be responsible for any errors that may appear in this document. ZiLog, Inc. makes no commitment to update or keep current the information contained in this document.

ZiLog's products are not authorized for use as critical components in life support devices or systems unless a specific written agreement pertaining to such intended use is executed between the customer and ZiLog prior to use. Life support devices or systems are those which are intended for surgical implantation into the body, or which sustains life whose failure to perform, when properly used in accordance with instructions for use provided in the labeling, can be reasonably expected to result in significant injury to the user.

ZiLog, Inc. 210 East Hacienda Ave.
Campbell, CA 95008-6600
Telephone (408) 370-8000
Telex 910-338-7621
FAX 408 370-8056
Internet: <http://www.zilog.com>

Looking for pricing, stock, or lifecycle information?

Click below to explore more details on WIN SOURCE:

 [View Z16C3220VSG1660 on WIN SOURCE](#)

 [Zilog Information](#)

Optimize Your Supply Chain with WIN SOURCE Solutions

-  Global Sourcing Solution
-  Obsolete Management
-  Cost Control Management
-  Shortage Management
-  Alternative Solution
-  Excess Inventory Management