



**THE DATASHEET OF  
NLVASB3157DFT2G**



# NLASB3157

## SPDT, 3 Ω R<sub>ON</sub> Switch

The NLASB3157 is an advanced CMOS analog switch fabricated with silicon gate CMOS technology. It achieves very low propagation delay and R<sub>DS(ON)</sub> resistances while maintaining CMOS low power dissipation. Analog and digital voltages that may vary across the full power-supply range (from V<sub>CC</sub> to GND). This device is a drop in replacement for the NC7SB3157.

The select pin has overvoltage protection that allows voltages above V<sub>CC</sub>, up to 7.0 V to be present on the pin without damage or disruption of operation of the part, regardless of the operating voltage.

### Features

- High Speed: t<sub>PD</sub> = 1.0 ns (Typ) at V<sub>CC</sub> = 5.0 V
- Low Power Dissipation: I<sub>CC</sub> = 2.0 μA (Max) at T<sub>A</sub> = 25°C
- Standard CMOS Logic Levels
- High Bandwidth, Improved Linearity
- Switches Standard NTSC/PAL Video, Audio, SPDIF and HDTV
- May be used for Clock Switching, Data Multiplexing, etc.
- R<sub>ON</sub> Typical = 3 Ω @ V<sub>CC</sub> = 4.5 V
- Break Before Make Circuitry, Prevents Inadvertent Shorts
- 2 Devices can Switch Balanced Signal Pairs, e.g. LVDS > 200 Mb/s
- Latchup Performance Exceeds 300 mA
- Pin for Pin Drop in for NC7SB3157
- Tiny SC88 and WDFN6 Packages
- ESD Performance:
  - ◆ Human Body Model; > 2000 V;
  - ◆ Machine Model; > 200 V
- NLASB3157 Features Extended Automotive Temperature Range; -55°C to +125°C (See Appendix A)
- These Devices are Pb-Free, Halogen Free/BFR Free and are RoHS Compliant



**ON Semiconductor®**

[www.onsemi.com](http://www.onsemi.com)

### MARKING DIAGRAMS

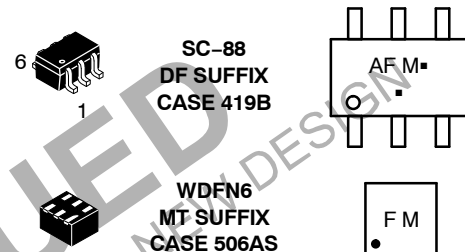

SC-88  
DF SUFFIX  
CASE 419B

WDFN6  
MT SUFFIX  
CASE 506AS

AF, F = Specific Device Code  
M = Date Code\*

▪ = Pb-Free Package

(Note: Microdot may be in either location)  
\*Date Code orientation may vary depending upon manufacturing location.

### FUNCTION TABLE

Select Input	Function
L	B0 Connected to A
H	B1 Connected to A

### ORDERING INFORMATION

Device	Package	Shipping†
NLASB3157DFT2G	SC-88 (Pb-Free)	3000 / Tape & Reel
NLNASB3157DFT2G	SC-88 (Pb-Free)	3000 / Tape & Reel
NLASB3157MTR2G	WDFN6 (Pb-Free)	3000 / Tape & Reel

†For information on tape and reel specifications, including part orientation and tape sizes, please refer to our Tape and Reel Packaging Specifications Brochure, BRD8011/D.

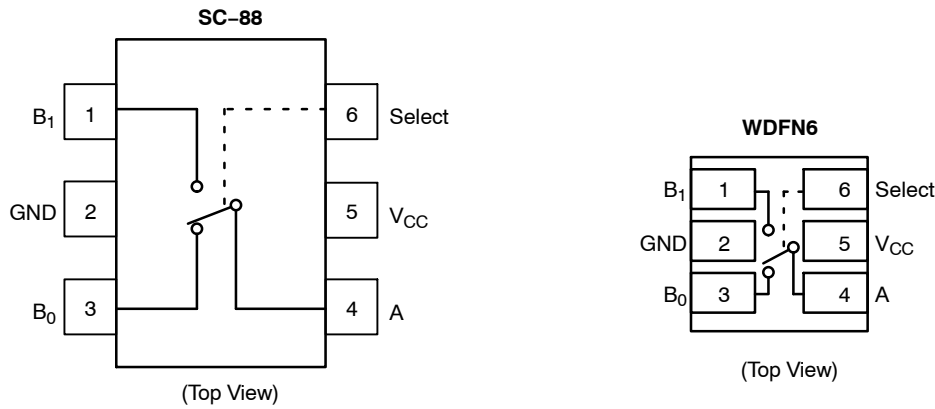

Figure 1. Pin Assignment & Logic Diagram

**MAXIMUM RATINGS**

Rating	Symbol	Value	Unit
Supply Voltage	$V_{CC}$	-0.5 to +7.0	V
DC Switch Voltage (Note 1)	$V_{IS}$	-0.5 to $V_{CC} + 0.5$	V
DC Input Voltage (Note 1)	$V_{IN}$	-0.5 to +7.0	V
DC Input Diode Current @ $V_{IN} < 0$ V	$I_{IK}$	-50	mA
DC Input / Output Current	$I_{OUT}$	128	mA
DC $V_{CC}$ or Ground Current	$I_{CC}/I_{GND}$	+100	mA
Storage Temperature Range	$T_{stg}$	-65 to +150	°C
Junction Temperature Under Bias	$T_J$	150	°C
Junction Lead Temperature (Soldering, 10 Seconds)	$T_L$	260	°C
Power Dissipation @ +85°C	$P_D$	180	mW

Stresses exceeding those listed in the Maximum Ratings table may damage the device. If any of these limits are exceeded, device functionality should not be assumed, damage may occur and reliability may be affected.

1. The input and output negative voltage ratings may be exceeded if the input and output diode current ratings are observed.

**RECOMMENDED OPERATING CONDITIONS (Note 2)**

Characteristic	Symbol	Min	Max	Unit
Supply Voltage Operating	$V_{CC}$	1.65	5.5	V
Select Input Voltage	$V_{IN}$	0	5.5	V
Switch Input Voltage	$V_{IS}$	0	$V_{CC}$	V
Output Voltage	$V_{OUT}$	0	$V_{CC}$	V
Operating Temperature	$T_A$	-55	+125	°C
Input Rise and Fall Time Control Input $V_{CC} = 2.3$ V-3.6 V Control Input $V_{CC} = 4.5$ V-5.5 V	$t_r, t_f$	0	10 5.0	ns/V
Thermal Resistance	$\theta_{JA}$	-	350	°C/W

Functional operation above the stresses listed in the Recommended Operating Ranges is not implied. Extended exposure to stresses beyond the Recommended Operating Ranges limits may affect device reliability.

2. Select input must be held HIGH or LOW, it must not float.

# NLASB3157

## DC ELECTRICAL CHARACTERISTICS – NLASB3157

Symbol	Parameter	Test Conditions	V <sub>CC</sub> (V)	T <sub>A</sub> = +25°C			T <sub>A</sub> = -40°C to +85°C		Unit
				Min	Typ	Max	Min	Max	
V <sub>IH</sub>	HIGH Level Input Voltage		1.65–1.95 2.3–5.5				0.75 V <sub>CC</sub> 0.7 V <sub>CC</sub>		V
V <sub>IL</sub>	LOW Level Input Voltage		1.65–1.95 2.3–5.5					0.25 V <sub>CC</sub> 0.3 V <sub>CC</sub>	V
I <sub>IN</sub>	Input Leakage Current	0 ≤ V <sub>IN</sub> ≤ 5.5 V	0–5.5		±0.05	±0.1		±1	μA
I <sub>OFF</sub>	OFF State Leakage Current	0 ≤ A, B ≤ V <sub>CC</sub>	1.65–5.5		±0.05	±0.1		±1	μA
R <sub>ON</sub>	Switch On Resistance (Note 3)	V <sub>IN</sub> = 0 V, I <sub>O</sub> = 30 mA	4.5		3.0			7.0	Ω
		V <sub>IN</sub> = 2.4 V, I <sub>O</sub> = -30 mA			5.0			12	
		V <sub>IN</sub> = 4.5 V, I <sub>O</sub> = -30 mA			7.0			15	
		V <sub>IN</sub> = 0 V, I <sub>O</sub> = 24 mA	3.0		4.0			9.0	Ω
		V <sub>IN</sub> = 3 V, I <sub>O</sub> = -24 mA			10			20	
		V <sub>IN</sub> = 0 V, I <sub>O</sub> = 8 mA	2.3		5.0			12	Ω
		V <sub>IN</sub> = 2.3 V, I <sub>O</sub> = -8 mA			13			30	
		V <sub>IN</sub> = 0 V, I <sub>O</sub> = 4 mA	1.65		6.5			20	Ω
		V <sub>IN</sub> = 1.65 V, I <sub>O</sub> = -4 mA			17			50	
I <sub>CC</sub>	Quiescent Supply Current All Channels ON or OFF	V <sub>IN</sub> = V <sub>CC</sub> or GND I <sub>OUT</sub> = 0	5.5			1.0		10	μA
	Analog Signal Range		V <sub>CC</sub>	0		V <sub>CC</sub>	0	V <sub>CC</sub>	V
R <sub>RANGE</sub>	On Resistance Over Signal Range (Note 3) (Note 7)	I <sub>A</sub> = -30 mA, 0 ≤ V <sub>Bn</sub> ≤ V <sub>CC</sub>	4.5					25	Ω
		I <sub>A</sub> = -24 mA, 0 ≤ V <sub>Bn</sub> ≤ V <sub>CC</sub>	3.0					50	
		I <sub>A</sub> = -8 mA, 0 ≤ V <sub>Bn</sub> ≤ V <sub>CC</sub>	2.3					100	
		I <sub>A</sub> = -4 mA, 0 ≤ V <sub>Bn</sub> ≤ V <sub>CC</sub>	1.65					300	
ΔR <sub>ON</sub>	On Resistance Match Between Channels (Note 3) (Note 4) (Note 5)	I <sub>A</sub> = -30 mA, V <sub>Bn</sub> = 3.15	4.5		0.15				Ω
		I <sub>A</sub> = -24 mA, V <sub>Bn</sub> = 2.1	3.0		0.2				
		I <sub>A</sub> = -8 mA, V <sub>Bn</sub> = 1.6	2.3		0.5				
		I <sub>A</sub> = -4 mA, V <sub>Bn</sub> = 1.15	1.65		0.5				
R <sub>flat</sub>	On Resistance Flatness (Note 3) (Note 4) (Note 6)	I <sub>A</sub> = -30 mA, 0 ≤ V <sub>Bn</sub> ≤ V <sub>CC</sub>	5.0		6.0				Ω
		I <sub>A</sub> = -24 mA, 0 ≤ V <sub>Bn</sub> ≤ V <sub>CC</sub>	3.3		12				
		I <sub>A</sub> = -8 mA, 0 ≤ V <sub>Bn</sub> ≤ V <sub>CC</sub>	2.5		28				
		I <sub>A</sub> = -4 mA, 0 ≤ V <sub>Bn</sub> ≤ V <sub>CC</sub>	1.8		125				

Product parametric performance is indicated in the Electrical Characteristics for the listed test conditions, unless otherwise noted. Product performance may not be indicated by the Electrical Characteristics if operated under different conditions.

3. Measured by the voltage drop between A and B pins at the indicated current through the switch. On Resistance is determined by the lower of the voltages on the two (A or B Ports).
4. Parameter is characterized but not tested in production.
5. ΔR<sub>ON</sub> = R<sub>ON</sub> max – R<sub>ON</sub> min measured at identical V<sub>CC</sub>, temperature and voltage levels.
6. Flatness is defined as the difference between the maximum and minimum value of On Resistance over the specified range of conditions.
7. Guaranteed by Design.

# NLASB3157

## AC ELECTRICAL CHARACTERISTICS – NLASB3157

Symbol	Parameter	Test Conditions	V <sub>CC</sub> (V)	T <sub>A</sub> = +25°C			T <sub>A</sub> = -40°C to +85°C		Unit	Figure Number
				Min	Typ	Max	Min	Max		
t <sub>PHL</sub> t <sub>PLH</sub>	Propagation Delay Bus to Bus (Note 9)	V <sub>I</sub> = OPEN	1.65–1.95 2.3–2.7 3.0–3.6 4.5–5.5					1.2 0.8 0.3	ns	Figures 2, 3
t <sub>PZL</sub> t <sub>PZH</sub>	Output Enable Time Turn On Time (A to B <sub>n</sub> )	V <sub>I</sub> = 2 × V <sub>CC</sub> for t <sub>PZL</sub> V <sub>I</sub> = 0 V for t <sub>PZH</sub>	1.65–1.95 2.3–2.7 3.0–3.6 4.5–5.5			23 13 6.9 5.2	7.0 3.5 2.5 1.7	24 14 7.6 5.7	ns	Figures 2, 3
t <sub>PLZ</sub> t <sub>PHZ</sub>	Output Disable Time Turn Off Time (A Port to B Port)	V <sub>I</sub> = 2 × V <sub>CC</sub> for t <sub>PLZ</sub> V <sub>I</sub> = 0 V for t <sub>PHZ</sub>	1.65–1.95 2.3–2.7 3.0–3.6 4.5–5.5			12.5 7.0 5.0 3.5	3.0 2.0 1.5 0.8	13 7.5 5.3 3.8	ns	Figures 2, 3
t <sub>B-M</sub>	Break Before Make Time (Note 8)		1.65–1.95 2.3–2.7 3.0–3.6 4.5–5.5					0.5 0.5 0.5 0.5	ns	Figure 4
Q	Charge Injection (Note 8)	C <sub>L</sub> = 0.1 nF, V <sub>GEN</sub> = 0 V R <sub>GEN</sub> = 0 Ω	5.0 3.3		7.0 3.0				pC	Figure 5
OIRR	Off Isolation (Note 10)	R <sub>L</sub> = 50 Ω f = 10 MHz	1.65–5.5		-57				dB	Figure 6
Xtalk	Crosstalk	R <sub>L</sub> = 50 Ω f = 10 MHz	1.65–5.5		-54				dB	Figure 7
BW	-3 dB Bandwidth	R <sub>L</sub> = 50 Ω	1.65–5.5		250				MHz	Figure 10
THD	Total Harmonic Distortion (Note 8)	R <sub>L</sub> = 600 Ω 0.5 V <sub>P-P</sub> f = 600 Hz to 20 kHz	5.0		0.011				%	

## CAPACITANCE – NLASB3157 (Note 11)

Symbol	Parameter	Test Conditions	Typ	Max	Unit	Figure Number
C <sub>IN</sub>	Select Pin Input Capacitance	V <sub>CC</sub> = 0 V	2.3		pF	
C <sub>IO-B</sub>	B Port Off Capacitance	V <sub>CC</sub> = 5.0 V	6.5		pF	Figure 8
C <sub>IOA-ON</sub>	A Port Capacitance when Switch is Enabled	V <sub>CC</sub> = 5.0 V	18.5		pF	Figure 9

8. Guaranteed by Design.

9. This parameter is guaranteed by design but not tested. The bus switch contributes no propagation delay other than the RC delay of the On Resistance of the switch and the 50 pF load capacitance, when driven by an ideal voltage source (zero output impedance).

10. Off Isolation = 20 log<sub>10</sub> [V<sub>A</sub>/V<sub>Bn</sub>].

11. T<sub>A</sub> = +25°C, f = 1 MHz, Capacitance is characterized but not tested in production.

APPENDIX A

DC ELECTRICAL EXTENDED AUTOMOTIVE TEMPERATURE RANGE CHARACTERISTICS – NLVASB3157

Symbol	Parameter	Test Conditions	V <sub>CC</sub> (V)	T <sub>A</sub> = +25°C			T <sub>A</sub> = -55°C to +125°C		Unit
				Min	Typ	Max	Min	Max	
V <sub>IH</sub>	HIGH Level Input Voltage		1.65–1.95 2.3–5.5				0.75 V <sub>CC</sub> 0.7 V <sub>CC</sub>		V
V <sub>IL</sub>	LOW Level Input Voltage		1.65–1.95 2.3–5.5					0.25 V <sub>CC</sub> 0.3 V <sub>CC</sub>	V
I <sub>IN</sub>	Input Leakage Current	0 ≤ V <sub>IN</sub> ≤ 5.5 V	0–5.5		±0.05	±0.1		±1	μA
I <sub>OFF</sub>	OFF State Leakage Current	0 ≤ A, B ≤ V <sub>CC</sub>	1.65–5.5		±0.05	±0.1		±1	μA
R <sub>ON</sub>	Switch On Resistance (Note 12)	V <sub>IN</sub> = 0 V, I <sub>O</sub> = 30 mA V <sub>IN</sub> = 2.4 V, I <sub>O</sub> = -30 mA V <sub>IN</sub> = 4.5 V, I <sub>O</sub> = -30 mA	4.5		3.0 5.0 7.0			8.5 13.0 15.0	Ω
		V <sub>IN</sub> = 0 V, I <sub>O</sub> = 24 mA V <sub>IN</sub> = 3 V, I <sub>O</sub> = -24 mA	3.0		4.0 10			11 20	
		V <sub>IN</sub> = 0 V, I <sub>O</sub> = 8 mA V <sub>IN</sub> = 2.3 V, I <sub>O</sub> = -8 mA	2.3		5.0 13			12 30	
		V <sub>IN</sub> = 0 V, I <sub>O</sub> = 4 mA V <sub>IN</sub> = 1.65 V, I <sub>O</sub> = -4 mA	1.65		6.5 17			20 50	
I <sub>CC</sub>	Quiescent Supply Current All Channels ON or OFF	V <sub>IN</sub> = V <sub>CC</sub> or GND  I <sub>OUT</sub> = 0	5.5			1.0		10	μA
	Analog Signal Range		V <sub>CC</sub>	0		V <sub>CC</sub>	0	V <sub>CC</sub>	V
R <sub>RANGE</sub>	On Resistance Over Signal Range (Note 12) (Note 14)	I <sub>A</sub> = -30 mA, 0 ≤ V <sub>Bn</sub> ≤ V <sub>CC</sub> I <sub>A</sub> = -24 mA, 0 ≤ V <sub>Bn</sub> ≤ V <sub>CC</sub> I <sub>A</sub> = -8 mA, 0 ≤ V <sub>Bn</sub> ≤ V <sub>CC</sub> I <sub>A</sub> = -4 mA, 0 ≤ V <sub>Bn</sub> ≤ V <sub>CC</sub>	4.5 3.0 2.3 1.65					25 50 100 300	Ω

12. Measured by the voltage drop between A and B pins at the indicated current through the switch. On Resistance is determined by the lower of the voltages on the two (A or B Ports).

13. Flatness is defined as the difference between the maximum and minimum value of On Resistance over the specified range of conditions.

14. Guaranteed by Design.

\* For ΔR<sub>ON</sub>, R<sub>FLAT</sub>, Q, OIRR, Xtalk, BW, THD, and CIN see -40°C to 85°C section.

# NLASB3157

## APPENDIX A

### AC ELECTRICAL EXTENDED AUTOMOTIVE TEMPERATURE RANGE CHARACTERISTICS – NLVASB3157

Symbol	Parameter	Test Conditions	V <sub>CC</sub> (V)	T <sub>A</sub> = +25°C			T <sub>A</sub> = -55°C to +125°C		Unit	Figure Number
				Min	Typ	Max	Min	Max		
t <sub>PHL</sub> t <sub>PLH</sub>	Propagation Delay Bus to Bus (Note 16)	V <sub>I</sub> = OPEN	1.65–1.95 2.3–2.7 3.0–3.6 4.5–5.5					1.2 0.8 0.3	ns	Figures 2, 3
t <sub>PZL</sub> t <sub>PZH</sub>	Output Enable Time Turn On Time (A to B <sub>n</sub> )	V <sub>I</sub> = 2 × V <sub>CC</sub> for t <sub>PZL</sub> V <sub>I</sub> = 0 V for t <sub>PZH</sub>	1.65–1.95 2.3–2.7 3.0–3.6 4.5–5.5			23 13 6.9 5.2	7.0 3.5 2.5 1.7	24 14 9.0 7.0	ns	Figures 2, 3
t <sub>PLZ</sub> t <sub>PHZ</sub>	Output Disable Time Turn Off Time (A Port to B Port)	V <sub>I</sub> = 2 × V <sub>CC</sub> for t <sub>PLZ</sub> V <sub>I</sub> = 0 V for t <sub>PHZ</sub>	1.65–1.95 2.3–2.7 3.0–3.6 4.5–5.5			12.5 7.0 5.0 3.5	3.0 2.0 1.5 0.8	13 7.5 6.5 5.0	ns	Figures 2, 3
t <sub>B-M</sub>	Break Before Make Time (Note 15)		1.65–1.95 2.3–2.7 3.0–3.6 4.5–5.5				0.5 0.5 0.5 0.5		ns	Figure 4

15. Guaranteed by Design.

16. This parameter is guaranteed by design but not tested. The bus switch contributes no propagation delay other than the RC delay of the On Resistance of the switch and the 50 pF load capacitance, when driven by an ideal voltage source (zero output impedance).

\* For  $\Delta R_{ON}$ ,  $R_{FLAT}$ , Q, OIRR, Xtalk, BW, THD, and CIN see -40°C to 85°C section.

DISCONTINUED

THIS DEVICE IS NOT RECOMMENDED FOR NEW DESIGN  
PLEASE CONTACT YOUR onsemi REPRESENTATIVE FOR INFORMATION

AC LOADING AND WAVEFORMS

NOTE: Input driven by 50 Ω source terminated in 50 Ω  
 NOTE:  $C_L$  includes load and stray capacitance  
 NOTE: Input PRR = 1.0 MHz;  $t_W$  = 500 ns

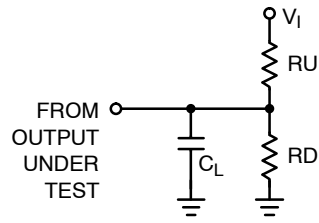

Figure 2. AC Test Circuit

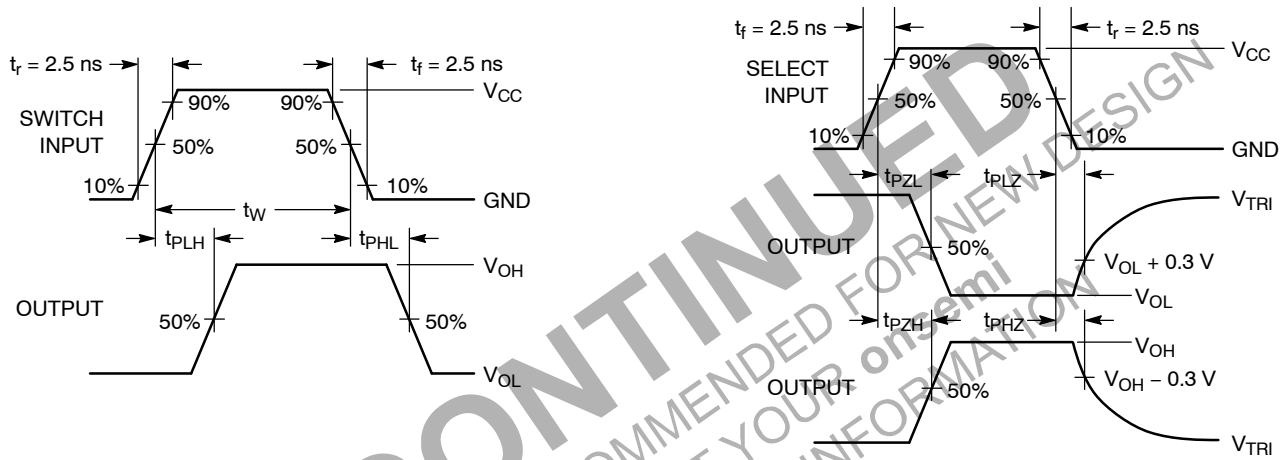
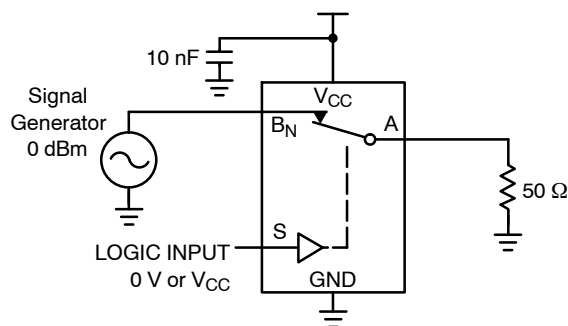
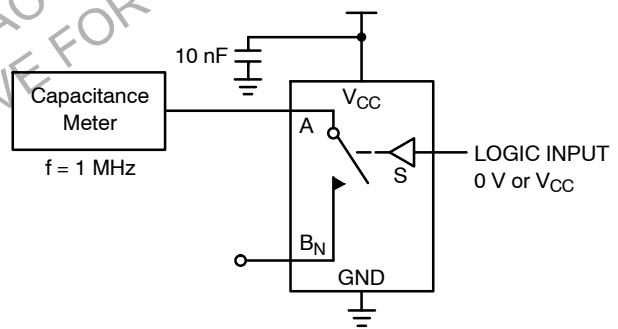
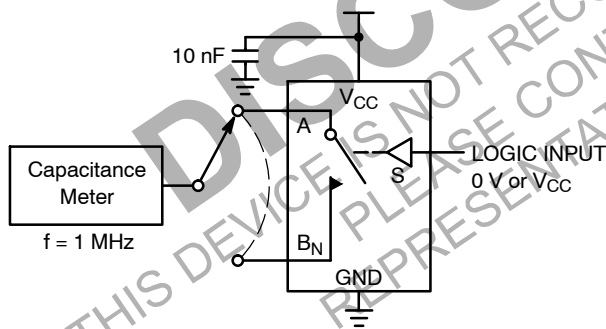
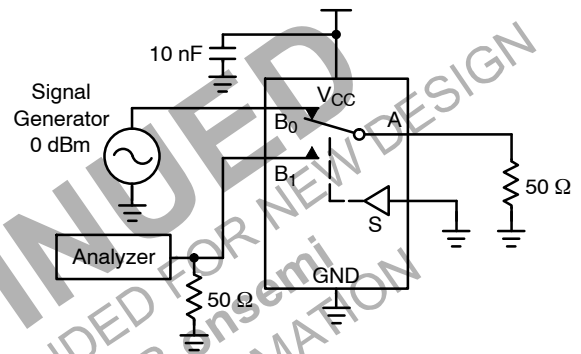
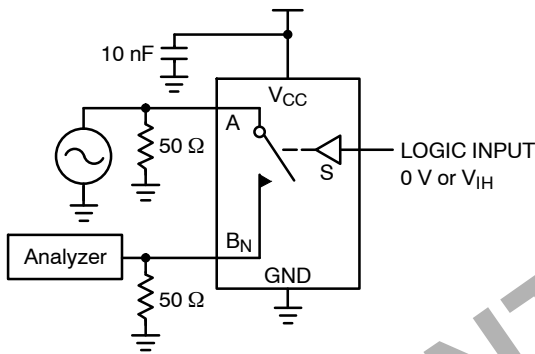
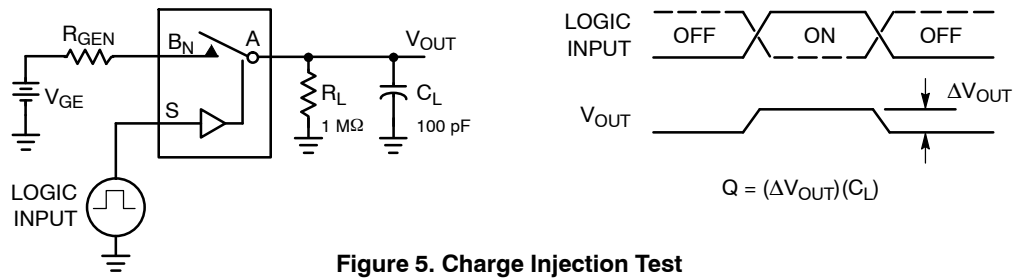

Figure 3. AC Waveforms



Figure 4. Break Before Make Interval Timing

AC LOADING AND WAVEFORMS



# MECHANICAL CASE OUTLINE PACKAGE DIMENSIONS



**SC-88 2.00x1.25x0.90, 0.65P**  
CASE 419B-02  
ISSUE Z

DATE 18 APR 2024

NOTES:

1. DIMENSIONING AND TOLERANCING CONFORM TO ASME Y14.5-2018.
2. ALL DIMENSION ARE IN MILLIMETERS.
3. DIMENSIONS D AND E1 DO NOT INCLUDE MOLD FLASH, PROTRUSIONS, OR GATE BURRS. MOLD FLASH, PROTRUSIONS, OR GATE BURRS SHALL NOT EXCEED 0.20 PER END.
4. DIMENSIONS D AND E1 AT THE OUTERMOST EXTREMES OF THE PLASTIC BODY AND DATUM H.
5. DATUMS A AND B ARE DETERMINED AT DATUM H.
6. DIMENSIONS b AND c APPLY TO THE FLAT SECTION OF THE LEAD BETWEEN 0.08 AND 0.15 FROM THE TIP.
7. DIMENSION b DOES NOT INCLUDE DAMBAR PROTRUSION. ALLOWABLE DAMBAR PROTRUSION SHALL BE 0.08 TOTAL IN EXCESS OF DIMENSION b AT MAXIMUM MATERIAL CONDITION. THE DAMBAR CANNOT BE LOCATED ON THE LOWER RADIUS OF THE FOOT.

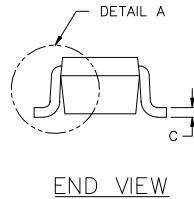
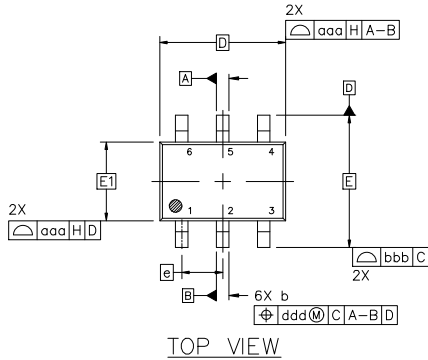

DIM	MILLIMETERS		
	MIN.	NOM.	MAX.
A	---	---	1.10
A1	0.00	---	0.10
A2	0.70	0.90	1.00
b	0.15	0.20	0.25
c	0.08	0.15	0.22
D	2.00 BSC		
E	2.10 BSC		
E1	1.25 BSC		
e	0.65 BSC		
L	0.26	0.36	0.46
L2	0.15 BSC		
aaa	0.15		
bbb	0.30		
ccc	0.10		
ddd	0.10		

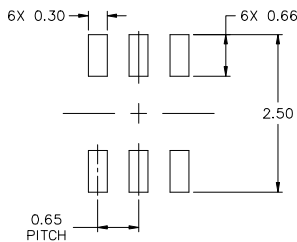

**GENERIC MARKING DIAGRAM\***



XXX = Specific Device Code  
M = Date Code\*  
▪ = Pb-Free Package

(Note: Microdot may be in either location)

\*Date Code orientation and/or position may vary depending upon manufacturing location.

\*This information is generic. Please refer to device data sheet for actual part marking. Pb-Free indicator, "G" or microdot "▪", may or may not be present. Some products may not follow the Generic Marking.

FOR ADDITIONAL INFORMATION ON OUR Pb-FREE STRATEGY AND SOLDERING DETAILS, PLEASE DOWNLOAD THE ONSEMI SOLDERING AND MOUNTING TECHNIQUES REFERENCE MANUAL, SOLDERRM/D.

**STYLES ON PAGE 2**

<b>DOCUMENT NUMBER:</b>	<b>98ASB42985B</b>	Electronic versions are uncontrolled except when accessed directly from the Document Repository. Printed versions are uncontrolled except when stamped "CONTROLLED COPY" in red.
<b>DESCRIPTION:</b>	<b>SC-88 2.00x1.25x0.90, 0.65P</b>	<b>PAGE 1 OF 2</b>

onsemi and ONSEMI are trademarks of Semiconductor Components Industries, LLC dba onsemi or its subsidiaries in the United States and/or other countries. onsemi reserves the right to make changes without further notice to any products herein. onsemi makes no warranty, representation or guarantee regarding the suitability of its products for any particular purpose, nor does onsemi assume any liability arising out of the application or use of any product or circuit, and specifically disclaims any and all liability, including without limitation special, consequential or incidental damages. onsemi does not convey any license under its patent rights nor the rights of others.

**SC-88 2.00x1.25x0.90, 0.65P**  
**CASE 419B-02**  
**ISSUE Z**

DATE 18 APR 2024

<b>STYLE 1:</b> PIN 1. EMITTER 2 2. BASE 2 3. COLLECTOR 1 4. EMITTER 1 5. BASE 1 6. COLLECTOR 2	<b>STYLE 2:</b> CANCELLED	<b>STYLE 3:</b> CANCELLED	<b>STYLE 4:</b> PIN 1. CATHODE 2. CATHODE 3. COLLECTOR 4. EMITTER 5. BASE 6. ANODE	<b>STYLE 5:</b> PIN 1. ANODE 2. ANODE 3. COLLECTOR 4. EMITTER 5. BASE 6. CATHODE	<b>STYLE 6:</b> PIN 1. ANODE 2 2. N/C 3. CATHODE 1 4. ANODE 1 5. N/C 6. CATHODE 2
<b>STYLE 7:</b> PIN 1. SOURCE 2 2. DRAIN 2 3. GATE 1 4. SOURCE 1 5. DRAIN 1 6. GATE 2	<b>STYLE 8:</b> CANCELLED	<b>STYLE 9:</b> PIN 1. EMITTER 2 2. EMITTER 1 3. COLLECTOR 1 4. BASE 1 5. BASE 2 6. COLLECTOR 2	<b>STYLE 10:</b> PIN 1. SOURCE 2 2. SOURCE 1 3. GATE 1 4. DRAIN 1 5. DRAIN 2 6. GATE 2	<b>STYLE 11:</b> PIN 1. CATHODE 2 2. CATHODE 2 3. ANODE 1 4. CATHODE 1 5. CATHODE 1 6. ANODE 2	<b>STYLE 12:</b> PIN 1. ANODE 2 2. ANODE 2 3. CATHODE 1 4. ANODE 1 5. ANODE 1 6. CATHODE 2
<b>STYLE 13:</b> PIN 1. ANODE 2. N/C 3. COLLECTOR 4. EMITTER 5. BASE 6. CATHODE	<b>STYLE 14:</b> PIN 1. VREF 2. GND 3. GND 4. IOUT 5. VEN 6. VCC	<b>STYLE 15:</b> PIN 1. ANODE 1 2. ANODE 2 3. ANODE 3 4. CATHODE 3 5. CATHODE 2 6. CATHODE 1	<b>STYLE 16:</b> PIN 1. BASE 1 2. EMITTER 2 3. COLLECTOR 2 4. BASE 2 5. EMITTER 1 6. COLLECTOR 1	<b>STYLE 17:</b> PIN 1. BASE 1 2. EMITTER 1 3. COLLECTOR 2 4. BASE 2 5. EMITTER 2 6. COLLECTOR 1	<b>STYLE 18:</b> PIN 1. VIN1 2. VCC 3. VOUT2 4. VIN2 5. GND 6. VOUT1
<b>STYLE 19:</b> PIN 1. IOUT 2. GND 3. GND 4. V CC 5. V EN 6. V REF	<b>STYLE 20:</b> PIN 1. COLLECTOR 2. COLLECTOR 3. BASE 4. EMITTER 5. COLLECTOR 6. COLLECTOR	<b>STYLE 21:</b> PIN 1. ANODE 1 2. N/C 3. ANODE 2 4. CATHODE 2 5. N/C 6. CATHODE 1	<b>STYLE 22:</b> PIN 1. D1 (i) 2. GND 3. D2 (i) 4. D2 (c) 5. VBUS 6. D1 (c)	<b>STYLE 23:</b> PIN 1. Vn 2. CH1 3. Vp 4. N/C 5. CH2 6. N/C	<b>STYLE 24:</b> PIN 1. CATHODE 2. ANODE 3. CATHODE 4. CATHODE 5. CATHODE 6. CATHODE
<b>STYLE 25:</b> PIN 1. BASE 1 2. CATHODE 3. COLLECTOR 2 4. BASE 2 5. EMITTER 6. COLLECTOR 1	<b>STYLE 26:</b> PIN 1. SOURCE 1 2. GATE 1 3. DRAIN 2 4. SOURCE 2 5. GATE 2 6. DRAIN 1	<b>STYLE 27:</b> PIN 1. BASE 2 2. BASE 1 3. COLLECTOR 1 4. EMITTER 1 5. EMITTER 2 6. COLLECTOR 2	<b>STYLE 28:</b> PIN 1. DRAIN 2. DRAIN 3. GATE 4. SOURCE 5. DRAIN 6. DRAIN	<b>STYLE 29:</b> PIN 1. ANODE 2. ANODE 3. COLLECTOR 4. EMITTER 5. BASE/ANODE 6. CATHODE	<b>STYLE 30:</b> PIN 1. SOURCE 1 2. DRAIN 2 3. DRAIN 2 4. SOURCE 2 5. GATE 1 6. DRAIN 1

Note: Please refer to datasheet for style callout. If style type is not called out in the datasheet refer to the device datasheet pinout or pin assignment.

<b>DOCUMENT NUMBER:</b>	<b>98ASB42985B</b>	Electronic versions are uncontrolled except when accessed directly from the Document Repository. Printed versions are uncontrolled except when stamped "CONTROLLED COPY" in red.
<b>DESCRIPTION:</b>	<b>SC-88 2.00x1.25x0.90, 0.65P</b>	<b>PAGE 2 OF 2</b>

**onsemi** and **ONSEMI** are trademarks of Semiconductor Components Industries, LLC dba **onsemi** or its subsidiaries in the United States and/or other countries. **onsemi** reserves the right to make changes without further notice to any products herein. **onsemi** makes no warranty, representation or guarantee regarding the suitability of its products for any particular purpose, nor does **onsemi** assume any liability arising out of the application or use of any product or circuit, and specifically disclaims any and all liability, including without limitation special, consequential or incidental damages. **onsemi** does not convey any license under its patent rights nor the rights of others.

# MECHANICAL CASE OUTLINE

## PACKAGE DIMENSIONS

ON Semiconductor®



### WDFN6 1.2x1.0, 0.4P CASE 506AS ISSUE D

DATE 27 AUG 2013



SCALE 4:1

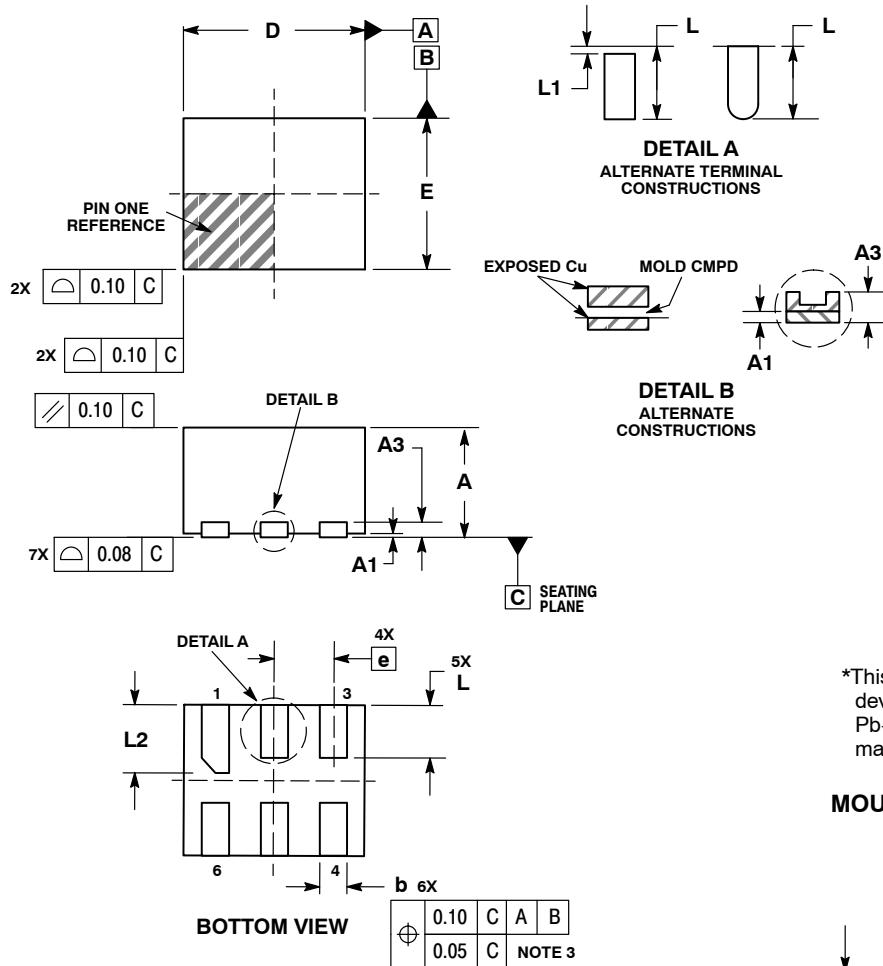

**NOTES:**

1. DIMENSIONING AND TOLERANCING PER ASME Y14.5M, 1994.
2. CONTROLLING DIMENSION: MILLIMETERS.
3. DIMENSION b APPLIES TO PLATED TERMINAL AND IS MEASURED BETWEEN 0.25 AND 0.30mm FROM TERMINAL.
4. COPLANARITY APPLIES TO THE EXPOSED PAD AS WELL AS THE TERMINALS.

DIM	MILLIMETERS	
	MIN	MAX
A	0.70	0.80
A1	0.00	0.05
A3	0.20 REF	
b	0.15	0.25
D	1.20 BSC	
E	1.00 BSC	
e	0.40 BSC	
L	0.30	0.40
L1	0.00	0.15
L2	0.40	0.50

### GENERIC MARKING DIAGRAM\*



X = Specific Device Code  
M = Date Code

\*This information is generic. Please refer to device data sheet for actual part marking. Pb-Free indicator, "G" or microdot "▪", may or may not be present.

### MOUNTING FOOTPRINT\*

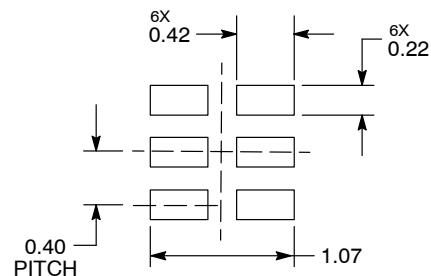

DIMENSIONS: MILLIMETERS

\*For additional information on our Pb-Free strategy and soldering details, please download the ON Semiconductor Soldering and Mounting Techniques Reference Manual, SOLDERRM/D.

- STYLE 1:  
PIN 1. DRAIN  
2. DRAIN  
3. GATE  
4. SOURCE  
5. DRAIN  
6. DRAIN

<b>DOCUMENT NUMBER:</b>	<b>98AON21223D</b>	Electronic versions are uncontrolled except when accessed directly from the Document Repository. Printed versions are uncontrolled except when stamped "CONTROLLED COPY" in red.
<b>DESCRIPTION:</b>	<b>WDFN6, 1.2 X 1.0, 0.4 P</b>	<b>PAGE 1 OF 1</b>

ON Semiconductor and are trademarks of Semiconductor Components Industries, LLC dba ON Semiconductor or its subsidiaries in the United States and/or other countries. ON Semiconductor reserves the right to make changes without further notice to any products herein. ON Semiconductor makes no warranty, representation or guarantee regarding the suitability of its products for any particular purpose, nor does ON Semiconductor assume any liability arising out of the application or use of any product or circuit, and specifically disclaims any and all liability, including without limitation special, consequential or incidental damages. ON Semiconductor does not convey any license under its patent rights nor the rights of others.

**onsemi**, **Onsemi**, and other names, marks, and brands are registered and/or common law trademarks of Semiconductor Components Industries, LLC dba "**onsemi**" or its affiliates and/or subsidiaries in the United States and/or other countries. **onsemi** owns the rights to a number of patents, trademarks, copyrights, trade secrets, and other intellectual property. A listing of **onsemi**'s product/patent coverage may be accessed at [www.onsemi.com/site/pdf/Patent-Marking.pdf](http://www.onsemi.com/site/pdf/Patent-Marking.pdf). **onsemi** reserves the right to make changes at any time to any products or information herein, without notice. The information herein is provided "as-is" and **onsemi** makes no warranty, representation or guarantee regarding the accuracy of the information, product features, availability, functionality, or suitability of its products for any particular purpose, nor does **onsemi** assume any liability arising out of the application or use of any product or circuit, and specifically disclaims any and all liability, including without limitation special, consequential or incidental damages. Buyer is responsible for its products and applications using **onsemi** products, including compliance with all laws, regulations and safety requirements or standards, regardless of any support or applications information provided by **onsemi**. "Typical" parameters which may be provided in **onsemi** data sheets and/or specifications can and do vary in different applications and actual performance may vary over time. All operating parameters, including "Typicals" must be validated for each customer application by customer's technical experts. **onsemi** does not convey any license under any of its intellectual property rights nor the rights of others. **onsemi** products are not designed, intended, or authorized for use as a critical component in life support systems or any FDA Class 3 medical devices or medical devices with a same or similar classification in a foreign jurisdiction or any devices intended for implantation in the human body. Should Buyer purchase or use **onsemi** products for any such unintended or unauthorized application, Buyer shall indemnify and hold **onsemi** and its officers, employees, subsidiaries, affiliates, and distributors harmless against all claims, costs, damages, and expenses, and reasonable attorney fees arising out of, directly or indirectly, any claim of personal injury or death associated with such unintended or unauthorized use, even if such claim alleges that **onsemi** was negligent regarding the design or manufacture of the part. **onsemi** is an Equal Opportunity/Affirmative Action Employer. This literature is subject to all applicable copyright laws and is not for resale in any manner.

---

## ADDITIONAL INFORMATION

### TECHNICAL PUBLICATIONS:

Technical Library: [www.onsemi.com/design/resources/technical-documentation](http://www.onsemi.com/design/resources/technical-documentation)  
onsemi Website: [www.onsemi.com](http://www.onsemi.com)

### ONLINE SUPPORT: [www.onsemi.com/support](http://www.onsemi.com/support)

For additional information, please contact your local Sales Representative at [www.onsemi.com/support/sales](http://www.onsemi.com/support/sales)

## Looking for pricing, stock, or lifecycle information?

Click below to explore more details on WIN SOURCE:

- ⊖ [View NLVASB3157DFT2G on WIN SOURCE](#)
- ⊖ [ON Semiconductor Information](#)

## Optimize Your Supply Chain with WIN SOURCE Solutions

- ✓ Global Sourcing Solution
- ✓ Obsolete Management
- ✓ Cost Control Management
- ✓ Shortage Management
- ✓ Alternative Solution
- ✓ Excess Inventory Management