

ISOUSB211 High/Full/Low Speed Isolated USB Repeater

1 Features

- Compliant to USB 2.0
- Supports low speed (1.5 Mbps), full speed (12 Mbps) and high speed (480 Mbps) signaling
- Does not need external crystal or clock input
- Automatic speed and connection detection
- Supports L1 (sleep) and L2 (suspend) low-power states
- Programmable equalization to compensate board trace loss in high speed mode
- CDP advertising on downstream side
- Supply OK indication on opposite side
- Supports automatic role reversal for USB On-The-Go (OTG) and Type-C® Dual Role Port (DRP) designs
- High CMTI: 100 kV/μs
- ±8 kV IEC 61000-4-2 contact discharge protection across isolation barrier
- V_{BUS} voltage range: 4.25 V to 5.5 V
 - 3.3 V and 1.8 V internal LDOs
- Meets CISPR32 class B emissions limits
- Ambient temperature range: -40°C to +125°C
- Small footprint 28-SSOP package
- Safety-related certifications:
 - 7071-V_{PK} V_{IOTM} and 2121-V_{PK} V_{IORM} (Reinforced) per DIN EN IEC 60747-17 (VDE 0884-17)
 - 5000-V_{RMS} isolation for 1 minute per UL 1577
 - IEC 62368-1, IEC 60601-1 and IEC 61010-1 certifications
 - CQC, TUV and CSA certifications

2 Applications

- USB Hub, Host, Peripheral and Cable Isolation
- Medical
- Factory automation
- Motor drives
- Grid infrastructure
- Power delivery
- USB Audio

Reinforced Isolation Option

FEATURE	ISOUSB211
Protection Level	Reinforced
Surge Isolation Voltage	12800 V _{PK}
Isolation Rating	5000 V _{RMS}
Isolation Working Voltage	1500 V _{RMS} / 2121 V _{PK}

3 Description

ISOUSB211 is a galvanically-isolated USB 2.0 compliant repeater supporting low speed (1.5 Mbps), full speed (12 Mbps) and high speed (480 Mbps) signaling rates. The device supports automatic connect and speed detection, reflection of pull-ups/pull-downs, and link power management allowing drop-in USB hub, host, peripheral and cable isolation. The device also supports automatic role reversal - if after disconnect, a new connect is detected on the Upstream facing port, then the Upstream and Downstream port definitions are reversed. This feature enables the device to support USB On-The-Go (OTG) and Type-C Dual Role Port (DRP) implementations. The ISOUSB211 has inbuilt programmable equalization to cancel signal loss caused by board traces, which helps in meeting USB2.0 high-speed TX and RX eye-diagram templates. This device uses a silicon dioxide (SiO₂) insulation barrier with a withstand voltage of up to 5000 V_{RMS} and a working voltage of 1500 V_{RMS}. Used in conjunction with isolated power supplies, the device protects against high voltage, and prevents noise currents from the bus from entering the local ground. The ISOUSB211 device is available for reinforced isolation. It supports a wide ambient temperature range of -40°C to +125°C. The device is available in the small foot-print SSOP-28 (28-DP) package.

Device Information

PART NUMBER ⁽¹⁾	PACKAGE	BODY SIZE (NOM)
ISOUSB211	SSOP (28) DP	10.30 mm × 7.50 mm

- (1) For all available packages, see the orderable addendum at the end of the data sheet.

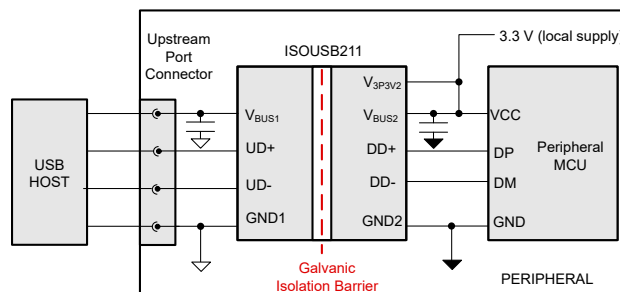

Application Diagram



Table of Contents

1 Features	1	8.1 Overview.....	22
2 Applications	1	8.2 Functional Block Diagram.....	22
3 Description	1	8.3 Feature Description.....	23
4 Revision History	2	8.4 Device Functional Modes.....	26
5 Pin Configuration and Functions	3	9 Power Supply Recommendations	27
6 Specifications	5	10 Application and Implementation	28
6.1 Absolute Maximum Ratings.....	5	10.1 Typical Application.....	28
6.2 ESD Ratings.....	5	10.2 Meeting USB2.0 HS Eye-Diagram Specifications...32	
6.3 Recommended Operating Conditions.....	5	10.3 Thermal Considerations.....	33
6.4 Thermal Information.....	6	11 Layout	37
6.5 Power Ratings.....	6	11.1 Layout Guidelines.....	37
6.6 Insulation Specifications.....	7	12 Device and Documentation Support	39
6.7 Safety-Related Certifications.....	8	12.1 Documentation Support.....	39
6.8 Safety Limiting Values.....	8	12.2 Receiving Notification of Documentation Updates..39	
6.9 Electrical Characteristics.....	9	12.3 Support Resources.....	39
6.10 Switching Characteristics.....	14	12.4 Trademarks.....	39
6.11 Insulation Characteristics Curves.....	18	12.5 Electrostatic Discharge Caution.....	39
6.12 Typical Characteristics.....	19	12.6 Glossary.....	39
7 Parameter Measurement Information	20	13 Mechanical, Packaging, and Orderable Information	39
7.1 Test Circuits.....	20	13.1 Tape and Reel Information.....	43
8 Detailed Description	22		

4 Revision History

NOTE: Page numbers for previous revisions may differ from page numbers in the current version.

Changes from Revision B (September 2022) to Revision C (January 2023)	Page
• Removed "Basic" option from data sheet.....	1

Changes from Revision A (March 2022) to Revision B (September 2022)	Page
• Updated device status to Production Data.....	1

Changes from Revision * (November 2021) to Revision A (March 2022)	Page
• T _A Max value updated to 125°C.....	5
• Updated Thermal Considerations section.....	33

5 Pin Configuration and Functions

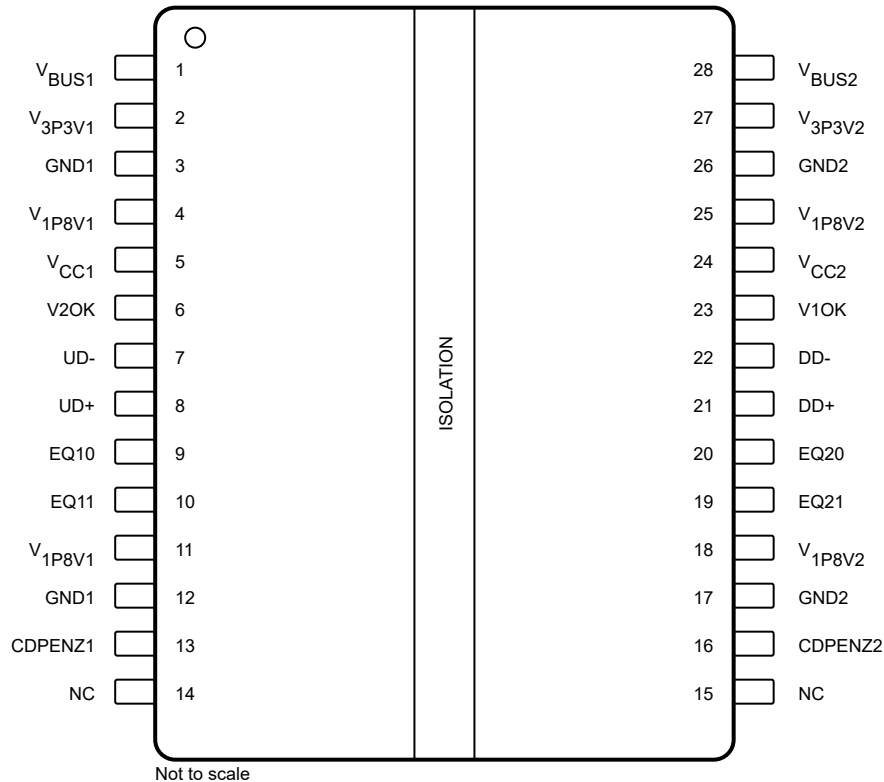

Figure 5-1. DP Package 28-Pin SSOP Top View

Table 5-1. Pin Functions—28 Pins

PIN		I/O	DESCRIPTION
NO.	NAME		
1	V _{BUS1}	—	Input Power Supply for Side 1. If a 4.25 V to 5.5 V (example USB power bus) supply is available connect it to V _{BUS1} . In this case an internal LDO generates V _{3P3V1} . Else, connect V _{BUS1} and V _{3P3V1} to an external 3.3 V power supply.
2	V _{3P3V1}	—	Power Supply for Side 1. If a 4.25 V to 5.5 V supply is connected to V _{BUS1} connect a bypass capacitor between V _{3P3V1} and GND1. In this case an internal LDO generates V _{3P3V1} . Else, connect V _{BUS1} and V _{3P3V1} to an external 3.3 V power supply.
3	GND1	—	Ground 1. Ground reference for Isolator Side 1.
4	V _{1P8V1}	—	Power Supply for Side 1. If a 2.4 V to 5.5 V supply is connected to V _{CC1} connect a bypass capacitor between V _{1P8V1} and GND1. In this case an internal LDO generates V _{1P8V1} . Else, connect V _{CC1} and V _{1P8V1} to an external 1.8 V power supply.
5	V _{CC1}	—	Input Power Supply for Side 1. If a 2.4 V to 5.5 V (example USB power bus, or a DC-DC supply derived from USB power bus) supply is available connect it to V _{CC1} . In this case an internal LDO generates V _{1P8V1} . Else, connect V _{CC1} and V _{1P8V1} to an external 1.8 V power supply.
6	V2OK	O	High level on this pin indicates that side 2 is powered up.
7	UD-	I/O	Upstream facing port D-.
8	UD+	I/O	Upstream facing port D+.
9	EQ10	I	Equalization setting for Side 1, LSB. Logic Input.
10	EQ11	I	Equalization setting for Side 1, MSB. Logic Input.
11	V _{1P8V1}	—	Connect pin 11 to pin 4, with local bypass capacitors near pin 11.
12	GND1	—	Ground 1. Ground reference for Isolator Side 1.
13	CDPENZ1	I	Active low singal. Enables CDP advertising on UD+/UD- pins.
14	NC	—	Leave floating or connect to V _{3P3V1} .

Table 5-1. Pin Functions—28 Pins (continued)

PIN		I/O	DESCRIPTION
NO.	NAME		
15	NC	—	Leave floating or connect to V _{3P3V2} .
16	CDPENZ2	I	Active low singal. Enables CDP advertising on DD+/DD- pins.
17	GND2	—	Ground 2. Ground reference for Isolator Side 2.
18	V _{1P8V2}	—	Connect pin 18 to pin 25, with local bypass capacitors near pin 18.
19	EQ21	I	Equalization setting for Side 2, MSB. Logic Input.
20	EQ20	I	Equalization setting for Side 2, LSB. Logic Input.
21	DD+	I/O	Downstream facing port D+.
22	DD-	I/O	Downstream facing port D-.
23	V1OK	O	High level on this pin indicates that side 1 is powered up.
24	V _{CC2}	—	Input Power Supply for Side 2. If a 2.4 V to 5.5 V (example USB power bus, or a DC-DC supply derived from USB power bus) supply is available connect it to V _{CC2} . In this case an internal LDO generates V _{1P8V2} . Else, connect V _{CC2} and V _{1P8V2} to an external 1.8 V power supply.
25	V _{1P8V2}	—	Power Supply for Side 1. If a 2.4 V to 5.5 V supply is connected to V _{CC2} connect a bypass capacitor between V _{1P8V2} and GND2. In this case an internal LDO generates V _{1P8V2} . Else, connect V _{CC2} and V _{1P8V2} to an external 1.8 V power supply.
26	GND2	—	Ground 2. Ground reference for Isolator Side 2.
27	V _{3P3V2}	—	Power Supply for Side 2. If a 4.25 V to 5.5 V supply is connected to V _{BUS2} connect a bypass capacitor between V _{3P3V2} and GND1. In this case an internal LDO generates V _{3P3V2} . Else, connect V _{BUS2} and V _{3P3V2} to an external 3.3 V power supply.
28	V _{BUS2}	—	Input Power Supply for Side 2. If a 4.25 V to 5.5 V (example USB power bus) supply is available connect it to V _{BUS2} . In this case an internal LDO generates V _{3P3V2} . Else, connect V _{BUS2} and V _{3P3V2} to an external 3.3 V power supply.

6 Specifications

6.1 Absolute Maximum Ratings

Over operating free-air temperature range (unless otherwise noted)^{(1) (2)}

		MIN	MAX	UNIT
V _{BUS1} , V _{BUS2}	V _{BUS} supply voltage	-0.3	6	V
V _{CC1} , V _{CC2}	V _{CC} supply voltage	-0.3	6	V
V _{3P3V1} , V _{3P3V2}	3.3-V input supply voltage	-0.3	4.25	V
V _{1P8V1} , V _{1P8V2}	1.8-V input supply voltage	-0.3	2.1	V
V _{DPDM}	Voltage on bus pins (UD+, UD-, DD+, DD-) 1000 total number of short events and cumulative duration of 1000 hrs.	-0.3	6	V
V _{IO}	IO voltage range (V*OK, EQ*, CDPENZ*)	-0.3	V _{3P3Vx} +0.3 ⁽³⁾	V
I _O	Output current on output pins (V*OK)	-10	10	mA
T _J	Junction temperature		150	°C
T _{STG}	Storage temperature	-65	150	°C

- (1) Stresses beyond those listed under *Absolute Maximum Rating* may cause permanent damage to the device. These are stress ratings only, which do not imply functional operation of the device at these or any other conditions beyond those indicated under *Recommended Operating Condition*. Exposure to absolute-maximum-rated conditions for extended periods may affect device reliability.
- (2) All voltage values are with respect to the local ground terminal (GND1 or GND2) and are peak voltage values.
- (3) Maximum voltage must not exceed 4.25 V

6.2 ESD Ratings

			VALUE	UNIT
V _(ESD)	Electrostatic discharge	Human body model (HBM), per ANSI/ESDA/JEDEC JS-001, all pins ⁽¹⁾	±1500	V
V _(ESD)	Electrostatic discharge	Charged device model (CDM), per JEDEC specification JESD22-C101, all pins ⁽²⁾	±500	V

- (1) JEDEC document JEP155 states that 500-V HBM allows safe manufacturing with a standard ESD control process.
- (2) JEDEC document JEP157 states that 250-V CDM allows safe manufacturing with a standard ESD control process.

6.3 Recommended Operating Conditions

Over operating free-air temperature range (unless otherwise noted)

		MIN	NOM	MAX	UNIT
V _{BUSx}	V _{BUS} input voltage (inclusive of any ripple)	4.25	5	5.5	V
V _{3P3Vx}	3.3-V input supply voltage (inclusive of any ripple)	3.0	3.3	3.6	V
V _{CCx}	Input voltage to internal 1.8V LDO (inclusive of any ripple)	2.4	3	5.5	V
V _{1P8Vx}	1.8-V input supply voltage (inclusive of any ripple)	1.71	1.8	1.94	V
T _A	Operating free-air temperature	-40		125	°C
T _J	Junction temperature	-55		150	°C

6.4 Thermal Information

THERMAL METRIC ⁽¹⁾		ISOUSB211	UNIT
		DP (SSOP)	
		28 PINS	
$R_{\theta JA}$	Junction-to-ambient thermal resistance	44.2	°C/W
$R_{\theta JC(top)}$	Junction-to-case (top) thermal resistance	13.9	°C/W
$R_{\theta JB}$	Junction-to-board thermal resistance	19.0	°C/W
Ψ_{JT}	Junction-to-top characterization parameter	3.3	°C/W
Ψ_{JB}	Junction-to-board characterization parameter	18.4	°C/W
$R_{\theta JC(bot)}$	Junction-to-case (bottom) thermal resistance	-	°C/W

(1) For more information about traditional and new thermal metrics, see the [Semiconductor and IC Package Thermal Metrics](#) application report.

6.5 Power Ratings

PARAMETER		TEST CONDITIONS	MIN	TYP	MAX	UNIT
ISOUSB211						
P_D	Maximum power dissipation (both sides)	$V_{BUS1} = V_{BUS2} = V_{CC1} = V_{CC2} = 5.5\text{ V}$, $T_J = 150^\circ\text{C}$, $R_L = 50\ \Omega$ each on DD- and DD+ to GNDx, input a 240-MHz 50% duty cycle adifferential 0 to 400mV swing signal on UD- and UD+			1232	mW
P_{D1}	Maximum power dissipation (side-1)	$V_{BUS1} = V_{BUS2} = V_{CC1} = V_{CC2} = 5.5\text{ V}$, $T_J = 150^\circ\text{C}$, $R_L = 50\ \Omega$ each on DD- and DD+ to GNDx, input a 240-MHz 50% duty cycle adifferential 0 to 400mV swing signal on UD- and UD+			616	mW
P_{D2}	Maximum power dissipation (side-2)	$V_{BUS1} = V_{BUS2} = V_{CC1} = V_{CC2} = 5.5\text{ V}$, $T_J = 150^\circ\text{C}$, $R_L = 50\ \Omega$ each on DD- and DD+ to GNDx, input a 240-MHz 50% duty cycle adifferential 0 to 400mV swing signal on UD- and UD+			616	mW

6.6 Insulation Specifications

PARAMETER		TEST CONDITIONS	SPECIFIC ACTIONS	UNIT
			DP-28	
IEC 60664-1				
CLR	External clearance ⁽¹⁾	Side 1 to side 2 distance through air	>8	mm
CPG	External Creepage ⁽¹⁾	Side 1 to side 2 distance across package surface	>8	mm
DTI	Distance through the insulation	Minimum internal gap (internal clearance)	>21	µm
CTI	Comparative tracking index	IEC 60112; UL 746A	>600	V
	Material Group	According to IEC 60664-1	I	
	Overvoltage category	Rated mains voltage ≤ 600 V _{RMS}	I-IV	
		Rated mains voltage ≤ 1000 V _{RMS}	I-III	
DIN EN IEC 60747-17 (VDE 0884-17)⁽²⁾				
V _{IORM}	Maximum repetitive peak isolation voltage	AC voltage (bipolar)	2121	V _{PK}
V _{IOWM}	Maximum isolation working voltage	AC voltage (sine wave); time-dependent dielectric breakdown (Tddb) test;	1500	V _{RMS}
		DC voltage	2121	V _{DC}
V _{IOTM}	Maximum transient isolation voltage	V _{TEST} = V _{IOTM} , t = 60 s (qualification); V _{TEST} = 1.2 × V _{IOTM} , t = 1 s (100% production)	8000	V _{PK}
V _{IMP}	Maximum impulse voltage ⁽³⁾	Tested in air, 1.2/50-µs waveform per IEC 62368-1	8000	V _{PK}
V _{IOSM}	Maximum surge isolation voltage ⁽³⁾	Tested in oil (qualification test), 1.2/50-µs waveform per IEC 62368-1	12800	V _{PK}
q _{pd}	Apparent charge ⁽⁴⁾	Method a, After Input/Output safety test subgroup 2/3, V _{ini} = V _{IOTM} , t _{ini} = 60 s; V _{pd(m)} = 1.2 × V _{IORM} , t _m = 10 s	≤ 5	pC
		Method a, After environmental tests subgroup 1, V _{ini} = V _{IOTM} , t _{ini} = 60 s; V _{pd(m)} = 1.6 × V _{IORM} , t _m = 10 s	≤ 5	
		Method b: At routine test (100% production) and preconditioning (type test); V _{ini} = 1.2 × V _{IOTM} , t _{ini} = 1 s; V _{pd(m)} = 1.875 × V _{IORM} , t _m = 1 s (method b1) or V _{pd(m)} = V _{ini} , t _m = t _{ini} (method b2)	≤ 5	
C _{IO}	Barrier capacitance, input to output ⁽⁵⁾	V _{IO} = 0.4 × sin (2 πft), f = 1 MHz	1.2	pF
R _{IO}	Insulation resistance, input to output ⁽⁵⁾	V _{IO} = 500 V, T _A = 25°C	> 10 ¹²	W
		V _{IO} = 500 V, 100°C ≤ T _A ≤ 125°C	> 10 ¹¹	
		V _{IO} = 500 V at T _S = 150°C	> 10 ⁹	
	Pollution degree		2	
	Climatic category		40/125/21	
UL 1577				
V _{ISO}	Withstand isolation voltage	V _{TEST} = V _{ISO} , t = 60 s (qualification); V _{TEST} = 1.2 × V _{ISO} , t = 1 s (100% production)	5700	V _{RMS}

- (1) Care must be taken during board design so that the mounting pads of the isolator on the printed-circuit board (PCB) do not reduce creepage and clearance. Inserting grooves, ribs or both can help increase creepage distance on the PCB.
- (2) ISOUSB211 is suitable for safe electrical insulation only within the safety ratings. Compliance with the safety ratings shall be ensured by means of suitable protective circuits.
- (3) Testing is carried out in air or oil to determine the intrinsic surge immunity of the isolation barrier.
- (4) Apparent charge is electrical discharge caused by a partial discharge (pd).
- (5) All pins on each side of the barrier tied together creating a two-pin device.

6.7 Safety-Related Certifications

VDE	CSA	UL	CQC	TUV
Certified according to DIN EN IEC 60747-17 (VDE 0884-17)	Certified according to IEC 61010-1, IEC 62368-1 and IEC 60601-1	Recognized under UL 1577 Component Recognition Program	Certified according to GB 4943.1	Certified according to EN 61010-1 and EN 62368-1
Reinforced Insulation; Maximum transient isolation voltage, ISOUSB211: 8000 V _{PK} Maximum repetitive peak isolation voltage, 2121 V _{PK} ; Maximum surge isolation voltage, ISOUSB211: 12800 V _{PK} (Reinforced)	Reinforced insulation per CSA 62368-1 and IEC 62368-1 ISOUSB211: 800 V _{RMS} Maximum working voltage (pollution degree 2, material group I); ISOUSB211: 2 MOPP ----- (Means of Patient Protection) per CSA 60601-1 and IEC 60601-1, 250 V _{RMS} maximum working voltage	Single protection, ISOUSB211: 5700 V _{RMS}	Reinforced insulation, Altitude ≤ 5000 m, Tropical Climate, 700 V _{RMS} maximum working voltage	5000 V _{RMS} Reinforced insulation per EN 61010-1 up to working voltage of 600 V _{RMS} ----- 5000 V _{RMS} Reinforced insulation per EN 62368-1 up to working voltage of 800 V _{RMS}
Certificate number: 40040142	Master contract: 220991	File number: E181974	Certificate: CQC15001121716	Client ID: 77311

6.8 Safety Limiting Values

Safety limiting⁽¹⁾ intends to minimize potential damage to the isolation barrier upon failure of input or output circuitry.

PARAMETER		TEST CONDITIONS	MIN	TYP	MAX	UNIT
DP-28 PACKAGE						
I _S	Safety input, output, or supply current	R _{θJA} = 44.2°C/W, V _I = 5.5 V, T _J = 150°C, T _A = 25°C			514	mA
		R _{θJA} = 44.2°C/W, V _I = 3.6 V, T _J = 150°C, T _A = 25°C			785	mA
		R _{θJA} = 44.2°C/W, V _I = 1.94 V, T _J = 150°C, T _A = 25°C			1457	mA
P _S	Safety input, output, or total power	R _{θJA} = 44.2°C/W, T _J = 150°C, T _A = 25°C			2828	mW
T _S	Maximum safety temperature				150	°C

- (1) The maximum safety temperature, T_S, has the same value as the maximum junction temperature, T_J, specified for the device. The I_S and P_S parameters represent the safety current and safety power respectively. The maximum limits of I_S and P_S should not be exceeded. These limits vary with the ambient temperature, T_A. The junction-to-air thermal resistance, R_{θJA}, in the table is that of a device installed on a high-K test board for leaded surface-mount packages. Use these equations to calculate the value for each parameter:
 $T_J = T_A + R_{\theta JA} \times P$, where P is the power dissipated in the device.
 $T_{J(max)} = T_S = T_A + R_{\theta JA} \times P_S$, where T_{J(max)} is the maximum allowed junction temperature.
 $P_S = I_S \times V_I$, where V_I is the maximum input voltage.

6.9 Electrical Characteristics

Over recommended operating conditions (unless otherwise noted). All typical values are at $T_A = 25^\circ\text{C}$, $V_{\text{BUSx}} = 5\text{ V}$, $V_{3\text{P3Vx}} = 3.3\text{ V}$, $V_{1\text{P8Vx}} = 1.8\text{ V}$.

PARAMETER		TEST CONDITIONS	MIN	TYP	MAX	UNIT
SUPPLY CHARACTERISTICS						
I_{VBUSx} or I_{V3P3Vx}	V_{BUS} or $V_{3\text{P3V}}$ current consumption - High Speed (HS) mode	Receive side HS Active (240 MHz signal rate), $\text{EQxx} = 00$, $R_L = 45\ \Omega$ to ground on D+ and D-		10.5	13.5	mA
		Transmit side HS Active (240 MHz signal rate), $\text{EQxx} = 00$, $R_L = 45\ \Omega$ to ground on D+ and D-		10.5	13.5	mA
		HS Idle State, $\text{EQxx} = 00$, $R_L = 45\ \Omega$ to ground on D+ and D-		10.5	13.5	mA
I_{VBUSx} or I_{V3P3Vx}	V_{BUS} or $V_{3\text{P3V}}$ current consumption - Full Speed (FS) and Low Speed (LS) modes	Receive side FS Active (6 MHz signal rate), Figure 7-9, $C_L = 50\ \text{pF}$		12	15.3	mA
		Transmit side FS Active (6 MHz signal rate), Figure 7-9, $C_L = 50\ \text{pF}$		9.5	13	mA
		Receive side LS Active (750 kHz signal rate), Figure 7-10, $C_L = 450\ \text{pF}$		11	13.5	mA
		Transmit side LS Active (750 kHz signal rate), Figure 7-10, $C_L = 450\ \text{pF}$		9.5	13	mA
		FS/LS Idle State (US side or DS side)		7.4	11	mA
I_{VBUSx} or I_{V3P3Vx}	V_{BUS} or $V_{3\text{P3V}}$ current consumption - L1 Sleep mode	Upstream Facing side		7.5	9.8	mA
		Downstream Facing side		7.3	9.5	mA
I_{VBUSx} or I_{V3P3Vx}	V_{BUS} or $V_{3\text{P3V}}$ current consumption - L2 Suspend mode	Upstream Facing side		1.07	1.55	mA
		Downstream Facing side		5.6	7.5	mA
I_{VBUSx} or I_{V3P3Vx}	V_{BUS} or $V_{3\text{P3V}}$ current consumption - Not attached	Upstream Facing side		6.2	8.5	mA
		Downstream Facing side		6.2	8.9	mA
I_{VCCx} or I_{V1P8Vx}	I_{VCCx} or I_{V1P8Vx} current consumption - High Speed (HS) mode	Receive side HS Active (240 MHz signal rate), $\text{EQxx} = 00$, $R_L = 45\ \Omega$ to ground on D+ and D-		80	96	mA
		Transmit side HS Active (240 MHz signal rate), $\text{EQxx} = 00$, $R_L = 45\ \Omega$ to ground on D+ and D-		85	96	mA
		HS Idle State, $\text{EQxx} = 00$, $R_L = 45\ \Omega$ to ground on D+ and D-		77	90	mA
I_{VCCx} or I_{V1P8Vx}	I_{VCCx} or I_{V1P8Vx} current consumption - Full Speed (FS) and Low Speed (LS) modes	Receive side FS Active (6 MHz signal rate), Figure 7-9, $C_L = 50\ \text{pF}$		0.4	0.55	mA
		Transmit side FS Active (6 MHz signal rate), Figure 7-9, $C_L = 50\ \text{pF}$		0.4	0.55	mA
		Receive side LS Active (750 kHz signal rate), Figure 7-10, $C_L = 450\ \text{pF}$		0.4	0.55	mA
		Transmit side LS Active (750 kHz signal rate), Figure 7-10, $C_L = 450\ \text{pF}$		0.4	0.55	mA
		FS/LS Idle State		0.4	0.55	mA
I_{VCCx} or I_{V1P8Vx}	I_{VCCx} or I_{V1P8Vx} current consumption - L1 Sleep mode	Upstream Facing side		0.4	0.55	mA
		Downstream Facing side		0.4	0.55	mA
I_{VCCx} or I_{V1P8Vx}	I_{VCCx} or I_{V1P8Vx} current consumption - L2 Suspend mode	Upstream Facing side		0.4	0.55	mA
		Downstream Facing side		0.4	0.55	mA
I_{VCCx} or I_{V1P8Vx}	I_{VCCx} or I_{V1P8Vx} current consumption - Not attached	Upstream Facing side		0.4	0.55	mA
		Downstream Facing side		0.4	0.55	mA
$\text{UV}^+(\text{VBUSx})$ (1)	Under voltage threshold when supply voltage is rising, V_{BUS}				4.0	V

ISOUSB211

SLLSFC5C – NOVEMBER 2021 – REVISED JANUARY 2023

 Over recommended operating conditions (unless otherwise noted). All typical values are at $T_A = 25^\circ\text{C}$, $V_{\text{BUSx}} = 5\text{ V}$, $V_{3\text{P3Vx}} = 3.3\text{ V}$, $V_{1\text{P8Vx}} = 1.8\text{ V}$.

PARAMETER		TEST CONDITIONS	MIN	TYP	MAX	UNIT
$UV_{-(V_{\text{BUSx}})}$ (1)	Under voltage threshold when supply voltage is falling, V_{BUS}		3.6			V
$UVHYS_{(V_{\text{BUSx}})}$ (1)	Under voltage threshold hysteresis, V_{BUS}			0.08		V
$UV_{+(V_{3\text{P3Vx}})}$	Under voltage threshold when supply voltage is rising, $V_{3\text{P3V}}$				2.95	V
$UV_{-(V_{3\text{P3Vx}})}$	Under voltage threshold when supply voltage is falling, $V_{3\text{P3V}}$		1.95			V
$UVHYS_{(V_{3\text{P3Vx}})}$	Under voltage threshold hysteresis, $V_{3\text{P3V}}$			0.11		V
$UV_{+(V_{\text{CCx}})}$ (2)	Under voltage threshold when supply voltage is rising, V_{CC}				2.35	V
$UV_{-(V_{\text{CCx}})}$ (2)	Under voltage threshold when supply voltage is falling, V_{CC}		2			V
$UVHYS_{(V_{\text{CCx}})}$ (2)	Under voltage threshold hysteresis, V_{CC}			0.05		V
$UV_{+(V_{1\text{P8Vx}})}$	Under voltage threshold when supply voltage is rising, $V_{1\text{P8V}}$				1.66	V
$UV_{-(V_{1\text{P8Vx}})}$	Under voltage threshold when supply voltage is falling, $V_{1\text{P8V}}$		1.25			V
$UVHYS_{(V_{1\text{P8Vx}})}$	Under voltage threshold hysteresis, $V_{1\text{P8V}}$			0.05		V
DIGITAL INPUTS						
V_{IH}	High-level input voltage		0.7 x $V_{3\text{PV3x}}$			V
V_{IL}	Low-level input voltage			0.3 x $V_{3\text{PV3x}}$		V
V_{IHYS}	Input transition threshold hysteresis		0.3			V
I_{IH}	High-level input current				1	μA
I_{IL}	Low-level input current				10	μA
DIGITAL OUTPUTS (V10K, V20K)						
V_{OH}	High-level output voltage	$I_O = -3\text{ mA for } 3.0\text{ V} \leq V_{3\text{P3Vx}} \leq 3.6\text{ V}$	$V_{3\text{P3Vx}} - 0.2$			V
V_{OL}	Low-level output voltage	$I_O = 3\text{ mA for } 3.0\text{ V} \leq V_{3\text{P3Vx}} \leq 3.6\text{ V}$			0.2	V
UDx, DDx, INPUT CAPACITANCE AND TERMINATION						
$Z_{\text{INP}_x\text{Dx}}$	Impedance to GND, no pull up/down	$V_{\text{in}}=3.6\text{ V}$, $V_{3\text{P3Vx}}=3.0\text{ V}$, $T_J < 125^\circ\text{C}$, USB 2.0 Spec Section 7.1.6	300			k Ω
$C_{\text{IO}_x\text{Dx}}$	Capacitance to GND	Measured with VNA at 240MHz, Driver Hi-Z			10	pF
R_{PUI}	Bus Pull up Resistor on Upstream Facing Port (idle)	USB 2.0 Spec Section 7.1.5	0.9	1.1	1.575	k Ω
R_{PUR}	Bus Pull up Resistor on Upstream Facing Port (receiving)	USB 2.0 Spec Section 7.1.5	1.5	2.2	3	k Ω
R_{PD}	Bus Pull-down Resistor on Downstream Facing Port	USB 2.0 Spec Section 7.1.5	14.25	19	24.8	k Ω
V_{TERM}	Termination voltage for Upstream facing port pullup (RPU)	USB 2.0 Spec Section 7.1.5, measured on D+ or D- with pull up enabled on upstream port with external load disconnected.	3		3.6	V
V_{HSTERM}	Termination voltage in high speed	USB 2.0 Spec Section 7.1.6.2, The output voltage in the high-speed idle state	-10		10	mV

Over recommended operating conditions (unless otherwise noted). All typical values are at $T_A = 25^\circ\text{C}$, $V_{\text{BUSX}} = 5\text{ V}$, $V_{3P3VX} = 3.3\text{ V}$, $V_{1P8VX} = 1.8\text{ V}$.

PARAMETER		TEST CONDITIONS	MIN	TYP	MAX	UNIT
Z_{HSTERM}	Driver Output Resistance (which also serves as high-speed termination)	(VOH= 0 to 600mV) USB 2.0 Spec Section 7.1.1.1 and Figure 7-5.	40.5	45	49.5	Ω
UDx, DDx, INPUT LEVELS LS/FS						
V_{IH}	High (driven)	USB 2.0 Spec Section 7.1.4 (measured at connector)	2			V
V_{IHZ}	High (floating)	USB 2.0 Spec Section 7.1.4 (Host downstream port pull down resistor enabled and Device pulled up to 3.0 V - 3.6 V).	2.7		3.6	V
V_{IL}	Low	USB 2.0 Spec Section 7.1.4			0.8	V
V_{DI}	Differential Input Sensitivity	$(x\text{D+})-(x\text{D-})$); USB 2.0 Spec Figure 7-19; (measured at connector)	0.2			V
V_{CM}	Common Mode Range	Includes VDI range; USB 2.0 Spec Figure 7-19; (measured at connector)	0.8		2.5	V
UDx, DDx, OUTPUT LEVELS LS/FS						
V_{OL}	Low	USB 2.0 Spec Section 7.1.1, (measured at connector with RL of 0.9 k Ω to 3.6 V.)	0		0.3	V
V_{OH}	High (Driven)	USB 2.0 Spec Section 7.1.1 (measured at connector with RL of 14.25 k Ω to GND.)	2.8		3.6	V
V_{OSE1}	SE1	USB 2.0 Spec Section 7.1.1	0.8			V
Z_{FSTERM}	Driver Series Output Resistance	USB 2.0 Spec Section 7.1.1 and Figure 7-4, Measured during VOL or VOH	28		44	Ω
V_{CRS}	Output Signal Crossover Voltage	Measured as in USB 2.0 Spec Section 7.1.1 Figures 7-8, 7-9 and 7-10; Excluding the first transition from the Idle state	1.3		2	V
UDx, DDx, INPUT LEVELS HS						
V_{HSSQ}	High-speed squelch/no-squelch detection threshold	USB 2.0 Spec Section 7.1.7.2 (specification refers to peak differential signal amplitude), measured at 240MHz with increasing amplitude, $V_{\text{CM}}=-50\text{mV}$ to 500mV	100	116	150	mV
V_{HSDSC}	High-speed disconnect detection threshold $_{\text{HSDC}}$ typical values	USB 2.0 Spec Section 7.1.7.2 (specification refers to differential signal amplitude). $V_{\text{CM}} = -50\text{ mV}$ to 500 mV	525	575	625	mV
$V_{\text{CHIRP_TH}}$	Chirp detection threshold	Chirp detection threshold (measured as peak differential signal amplitude). $V_{\text{CM}} = -50\text{ mV}$ to 500 mV	70	215	365	mV
V_{HSRX}	High-speed differential input signaling levels data sensitivity	Peak-to-peak at 240 MHz			100	mV
V_{HSCM}	High-speed data signaling common mode voltage range (guideline for receiver)	USB 2.0 Spec Section 7.1.4.2, receiver should be able to receive with this common mode range	-50	200	500	mV
UDx, DDx, OUTPUT LEVELS HS						
V_{HSOH}	High-speed data signaling high	USB 2.0 Spec Section 7.1.7.2, measured single ended peak voltage per USB 2.0 test measurement spec, EQxx = 00, Test load is an ideal 45 Ω to GND on D+ and D-	360	400	440	mV

ISOUSB211

SLLSFC5C – NOVEMBER 2021 – REVISED JANUARY 2023

 Over recommended operating conditions (unless otherwise noted). All typical values are at $T_A = 25^\circ\text{C}$, $V_{\text{BUSX}} = 5\text{ V}$, $V_{3P3VX} = 3.3\text{ V}$, $V_{1P8VX} = 1.8\text{ V}$.

PARAMETER		TEST CONDITIONS	MIN	TYP	MAX	UNIT
V_{HSOL}	High-speed data signaling low	USB 2.0 Spec Section 7.1.7.2, measured single ended peak voltage per USB 2.0 test measurement spec, EQxx = 00, Test load is an ideal 45 Ω to GND on D+ and D-.	-10		10	mV
V_{HSOI}	High-speed data signaling idle, driver is off termination is on (measured single ended)	USB 2.0 Spec Section 7.1.7.2, PE disabled, Test load is an ideal 45 Ω to GND on D+ and D-.	-10		10	mV
V_{CHIRPJ}	Chirp J level (differential voltage)	USB 2.0 Spec Section 7.1.7.2, EQxx = 00, Test load is an ideal 45 Ω to GND on D+ and D-, with 2.2 k Ω pull-up to 3.3 V on D+.	700	850	1100	mV
V_{CHIRPK}	Chirp K level (differential voltage)	USB 2.0 Spec Section 7.1.7.2, EQxx = 00, Test load is an ideal 45 Ω to GND on D+ and D-, with 2.2 k Ω pull-up to 3.3 V on D+.	-900	-750	-500	mV
$U2_TX_{\text{CM}}$	High-speed TX DC Common Mode	Test load is an ideal 45 Ω to GND on D+ and D-.	-50	200	500	mV
EQUALIZATION AND PRE-EMPHASIS						
EQ_{HS}	High-speed RX Equalization	EQ1=low, EQ0=low, 240MHz	-0.24	0.46	0.75	dB
EQ_{HS}	High-speed RX Equalization	EQ1=low, EQ0=float, 240MHz	0.27	0.98	1.5	dB
EQ_{HS}	High-speed RX Equalization	EQ1=low, EQ0=high, 240MHz	0.70	1.50	2.2	dB
EQ_{HS}	High-speed RX Equalization	EQ1=float, EQ0=low, 240MHz	1.04	2.00	2.81	dB
EQ_{HS}	High-speed RX Equalization	EQ1=float, EQ0=float, 240MHz	1.45	2.68	3.8	dB
EQ_{HS}	High-speed RX Equalization	EQ1=float, EQ0=high, 240MHz	1.73	3.09	4.4	dB
EQ_{HS}	High-speed RX Equalization	EQ1=high, EQ0=low, 240MHz	2.00	3.46	4.7	dB
EQ_{HS}	High-speed RX Equalization	EQ1=high, EQ0=float, 240MHz	2.25	3.80	5.1	dB
EQ_{HS}	High-speed RX Equalization	EQ1=high, EQ0=high, 240MHz	2.25	3.80	5.1	dB
PE_{HS}	High-speed TX Pre-emphasis	EQ1=low, EQ0=low, 240MHz	0.25	0.48	0.75	dB
PE_{HS}	High-speed TX Pre-emphasis	EQ1=low, EQ0=float, 240MHz	0.62	0.9	1.2	dB
PE_{HS}	High-speed TX Pre-emphasis	EQ1=low, EQ0=high, 240MHz	0.89	1.36	1.5	dB
PE_{HS}	High-speed TX Pre-emphasis	EQ1=float, EQ0=low, 240MHz	1.4	1.7	2.0	dB
PE_{HS}	High-speed TX Pre-emphasis	EQ1=float, EQ0=float, 240MHz	1.7	2.1	2.5	dB
PE_{HS}	High-speed TX Pre-emphasis	EQ1=float, EQ0=high, 240MHz	2.1	2.5	2.9	dB
PE_{HS}	High-speed TX Pre-emphasis	EQ1=high, EQ0=low, 240MHz	2.7	3.2	3.7	dB
PE_{HS}	High-speed TX Pre-emphasis	EQ1=high, EQ0=float, 240MHz	3.4	4.0	4.6	dB
PE_{HS}	High-speed TX Pre-emphasis	EQ1=high, EQ0=high, 240MHz	3.4	4.0	4.6	dB
CDP						
$V_{\text{DM_SRC}}$	VDM_SRC Voltage	Load Current in the range of 0 to 250 μA	0.5		0.7	V
$I_{\text{DP_SINK}}$	IDP_SINK (D+)	D+ Voltage = 0 V to 0.7 V	25		175	μA
$V_{\text{DAT_REF+}}$	VDAT_REF comparator rising threshold		300		400	mV
$V_{\text{DAT_REF-}}$	VDAT_REF comparator falling threshold		275		385	mV
$V_{\text{DAT_REF_HYS}}$	VDAT_REF comparator hysteresis		15	20	25	mV
THERMAL SHUTDOWN						
TSD+	Thermal shutdown turn-on temperature		160	170	180	$^\circ\text{C}$
TSD-	Thermal shutdown turn-off temperature		150	160	170	$^\circ\text{C}$

Over recommended operating conditions (unless otherwise noted). All typical values are at $T_A = 25^\circ\text{C}$, $V_{\text{BUSx}} = 5\text{ V}$, $V_{3\text{P3Vx}} = 3.3\text{ V}$, $V_{1\text{P8Vx}} = 1.8\text{ V}$.

PARAMETER		TEST CONDITIONS	MIN	TYP	MAX	UNIT
TSD _{HYS}	Thermal shutdown hysteresis			10		°C

- (1) If V_{BUSx} pins are externally connected to the corresponding $V_{3\text{P3Vx}}$ pins, then UVLO thresholds on V_{BUSx} are governed by $UV^+_{(V3P3Vx)}$, $UV^-_{(V3P3Vx)}$ and $UVHYS_{(V3P3Vx)}$
- (2) If V_{CCx} pins are externally connected to the corresponding $V_{1\text{P8Vx}}$ pins, then UVLO thresholds on V_{CCx} are governed by $UV^+_{(V1P8Vx)}$, $UV^-_{(V1P8Vx)}$ and $UVHYS_{(V1P8Vx)}$

6.10 Switching Characteristics

Over recommended operating conditions (unless otherwise noted). All typical values are at $T_A = 25^\circ\text{C}$, $V_{\text{BUSx}} = 5\text{ V}$, $V_{3\text{P3Vx}} = 3.3\text{ V}$, $V_{1\text{P8Vx}} = 1.8\text{ V}$.

PARAMETER		TEST CONDITIONS	MIN	TYP	MAX	UNIT
POWER-UP TIMING						
T_{SUPRAMP}	Allowed power supply ramp-up times on V_{BUSx} , $V_{3\text{P3Vx}}$, V_{CCx} and $V_{1\text{P8Vx}}$ external power supplies		0.005		100	ms
T_{PWRUP}	Time taken for the device to power up, and recognize USB signaling, after valid power supply is provided on both side 1 and side 2.	All external power supplies are ramped up together with 5 μs power up time.		3.6	8	ms
UDx, DDx, HS Driver Switching Characteristics						
T_{HSR}	Rise Time (10% - 90%)	USB 2.0 Spec Section 7.1.2, ideal 45 Ω to GND loads on D+ and D-, EQxx = 00	310	370	510	ps
T_{HSF}	Fall Time (10% - 90%)	USB 2.0 Spec Section 7.1.2, ideal 45 Ω to GND loads on D+ and D-, EQxx = 00	310	370	510	ps
UDx, DDx, FS Driver Switching Characteristics						
T_{FR}	Rise Time (10% - 90%)	USB 2.0 Spec Figure 7-8, Figure 7-9, $C_L = 50\text{ pF}$	4		20	ns
T_{FF}	Fall Time (10% - 90%)	USB 2.0 Spec Figure 7-8, Figure 7-9, $C_L = 50\text{ pF}$	4		20	ns
T_{FRFM}	Differential Rise and Fall Time Matching ($T_{\text{FR}}/T_{\text{FM}}$)	USB 2.0 Spec 7.1.2, Excluding the first transition from the Idle state, Figure 7-9, $C_L = 50\text{ pF}$	90		111.1	%
UDx, DDx, LS Driver Switching Characteristics						
T_{LR}	Rise Time (10% - 90%)	USB 2.0 Spec Figures 7-8 and 7-10, with C_L range 50 pF to 600 pF.	75		300	ns
T_{LF}	Fall Time (10% - 90%)	USB 2.0 Spec Figures 7-8 and 7-10, with C_L range 50 pF to 600 pF.	75		300	ns
T_{LRFM}	Rise and Fall Time Matching (TLR/TFM), Excluding first transition from idle state.	USB 2.0 Spec Figures 7-8 and 7-10, with C_L range 50 pF to 600 pF.	80		125	%
REPEATER TIMING - CONNECT, DISCONNECT, RESET, L1, L2						
T_{FILTCNN}	Debounce filter on FS or LS Connect Detection		45	70	80	μs
T_{DDIS}	Time to detect disconnect at the DS facing port in LS/FS L0 mode.		2		7	μs
T_{DETRST}	Time taken to detect reset on US port in LS/FS L0 mode		0		7	μs
$T_{2\text{SUSP}}$	Time taken by the US side to detect suspend mode (L2) and draw less than 2.5 mA current when bus is continuously in idle state.		3		10	ms
$t_{\text{DRESUMEL1}}$	Maximum time to detect resume on the US and reflect/drive resume on the DS port from sleep/L1 state.				1	μs
$t_{\text{DRESUMEL2}}$	Maximum time to detect resume on the US and reflect/drive resume on the DS port from suspend/L2 state.				130	μs
t_{DWAKEL1}	Maximum time to detect and propagate remote wake when in sleep/L1 state.				5	μs
t_{DWAKEL2}	Maximum pulse width of remote wake that is guaranteed to be detected when in suspend/L2 state.				900	μs
t_{DRSMPROP}	Minimum duration of resume driven upstream and downstream after detecting remote wake when in suspend/L2 state.		1			ms

Over recommended operating conditions (unless otherwise noted). All typical values are at $T_A = 25^\circ\text{C}$, $V_{\text{BUSx}} = 5\text{ V}$, $V_{3P3Vx} = 3.3\text{ V}$, $V_{1P8Vx} = 1.8\text{ V}$.

PARAMETER		TEST CONDITIONS	MIN	TYP	MAX	UNIT
CMTI	Common mode transient immunity	PK-PK common mode noise, $V_{\text{CMPKPK}} = 1200\text{ V}$ during USB data transmission, see Figure 7-3	50	100		kV/ μs

ISOUSB211

SLLSFC5C – NOVEMBER 2021 – REVISED JANUARY 2023

 Over recommended operating conditions (unless otherwise noted). All typical values are at $T_A = 25^\circ\text{C}$, $V_{\text{BUSx}} = 5\text{ V}$, $V_{3P3Vx} = 3.3\text{ V}$, $V_{1P8Vx} = 1.8\text{ V}$.

PARAMETER		TEST CONDITIONS	MIN	TYP	MAX	UNIT
REPEATER TIMING - LS, FS						
T_{LSDD}	Low-speed Differential Data Propagation Delay	USB 2.0 spec section 7.1.14. Figure 7-52(C).			358	ns
T_{LSOP}	LS Data bit-width distortion after SOP	USB 2.0 spec section 7.1.14. Figure 7-52(C).	-40		25	ns
T_{LSJP}	LS repeater additive jitter - paired transition	USB 2.0 spec section 7.1.14. Figure 7-52(C).	-5		5	ns
T_{LSJN}	LS repeater additive jitter - next transition	USB 2.0 spec section 7.1.14. Figure 7-52(C).	-7.0		7.0	ns
T_{LST}	Minimum width of SE0 interval during LS differential transition - filtered out by the repeater	USB 2.0 spec section 7.1.4.		210		ns
T_{LEOPD}	Repeater EOP delay relative to T_{LSDD}	USB 2.0 spec section 7.1.14. Figure 7-53(C).	0		200	ns
T_{LESK}	SE0 skew caused by the repeater during LS EOP	USB 2.0 spec section 7.1.14. Figure 7-53(C).	-100		100	ns
T_{FSDD}	Full-Speed Differential Data Propagation Delay	USB 2.0 spec section 7.1.14. Figure 7-52(C).			70	ns
T_{FSOP}	FS Data bit-width distortion after SOP	USB 2.0 spec section 7.1.14. Figure 7-52(C).	-10		10	ns
T_{FSJP}	FS repeater additive jitter - paired transition	USB 2.0 spec section 7.1.14. Figure 7-52(C).	-2		2	ns
T_{FSJN}	FS repeater additive jitter - next transition	USB 2.0 spec section 7.1.14. Figure 7-52(C).	-6.0		6.0	ns
T_{FST}	Minimum width of SE0 interval during FS differential transition - filtered out by the repeater	USB 2.0 spec section 7.1.4.		14		ns
T_{FEOPD}	Repeater EOP delay relative to T_{FSDD}	USB 2.0 spec section 7.1.14. Figure 7-53(C).	0		17	ns
T_{FESK}	SE0 skew caused by the repeater during FS EOP	USB 2.0 spec section 7.1.14. Figure 7-53(C).	-15		15	ns
REPEATER TIMING - HS						
T_{HSSOPT}	High-speed Start of Packet Truncation	USB 2.0 spec, section 7.1.10.		6	8	UI
T_{HSEOPD}	High-speed End of Packet Dribble	USB 2.0 spec, section 7.1.13.		7	8	UI
T_{HSPD}	High-speed Propagation Delay	USB 2.0 spec, section 7.1.14.		2	3	4 ns
T_{HSTJ}	High-speed total additive jitter (output jitter - input jitter) of repeater (includes all complete SOP bits), RX EQ disabled, TX PE disabled.				120	ps
T_{HSRJ}	High-speed additive random jitter (output jitter - input jitter) of repeater (includes all complete SOP bits), RX EQ disabled, TX PE disabled.				35	ps
T_{HSDJ}	High-speed additive deterministic jitter (output jitter - input jitter) of repeater (includes all complete SOP bits), RX EQ disabled, TX PE disabled.				82	ps
T_{HSDIS}	Time window of continuous no transition during which the HS Disconnect Detector output must be sampled			36	82	ns
T_{FILT}	Time for which a Chirp J or Chirp K must be continuously detected (filtered) by hub or device during Reset handshake	USB 2.0 spec, section 7.1.7.5.		2.5		μs
CDP TIMING						
$T_{\text{VDMSRC_EN}}$	Time taken to enable VDMSRC on D- after detecting VDPSRC connection on D+				0.1	ms
$T_{\text{VDMSRC_DIS}}$	Time taken to disable VDMSRC on D- after detecting VDPSRC disconnection on D+				0.1	ms

Over recommended operating conditions (unless otherwise noted). All typical values are at $T_A = 25^\circ\text{C}$, $V_{\text{BUSx}} = 5\text{ V}$, $V_{3P3Vx} = 3.3\text{ V}$, $V_{1P8Vx} = 1.8\text{ V}$.

PARAMETER		TEST CONDITIONS	MIN	TYP	MAX	UNIT
$T_{\text{CON_IDPSIN}}$ K_{DIS}	Time taken to disable IDP_SINK on D+ after detecting connect				0.1	ms

6.11 Insulation Characteristics Curves

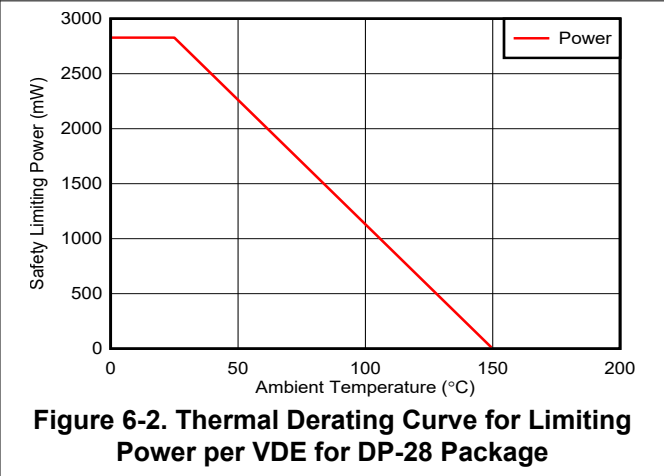
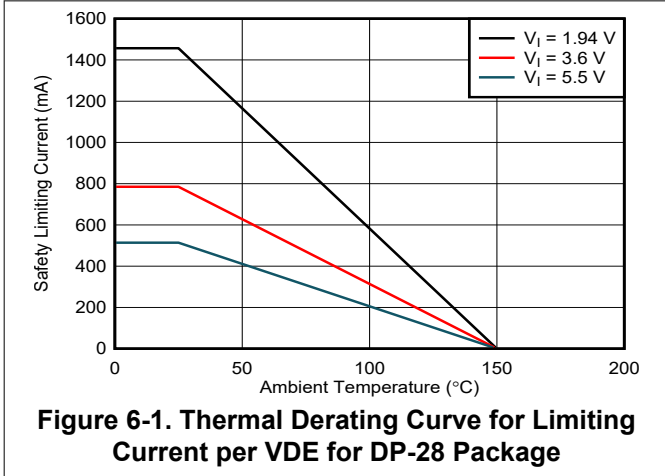

6.12 Typical Characteristics

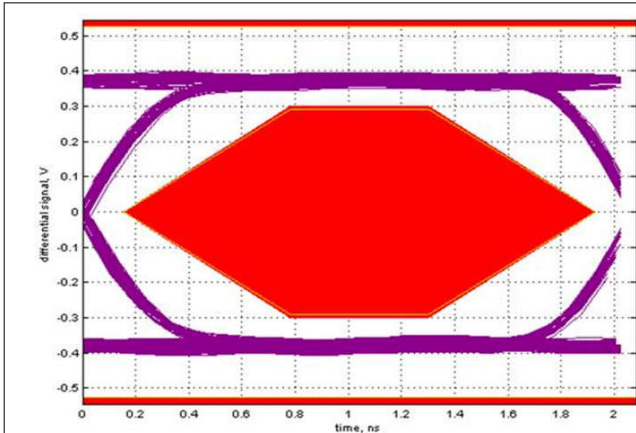

Figure 6-3. Typical High-Speed (480 Mbps) Eye-Diagram through ISOUSB211

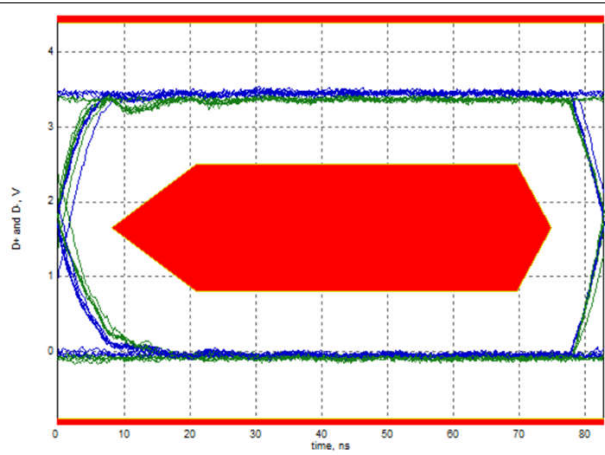

Figure 6-4. Typical Full-Speed (12 Mbps) Eye-Diagram through ISOUSB211

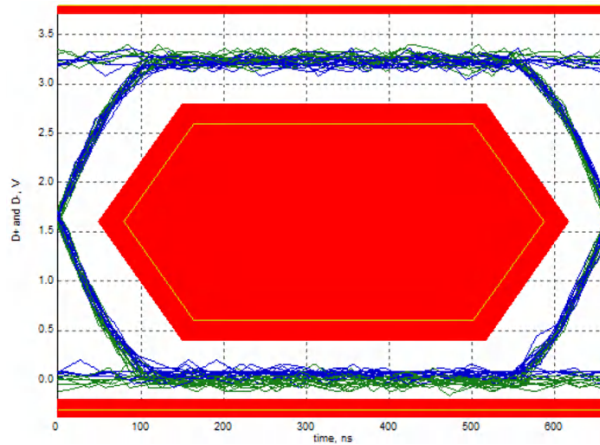

Figure 6-5. Typical Low-Speed (1.5 Mbps) Eye-Diagram through ISOUSB211

7 Parameter Measurement Information

7.1 Test Circuits

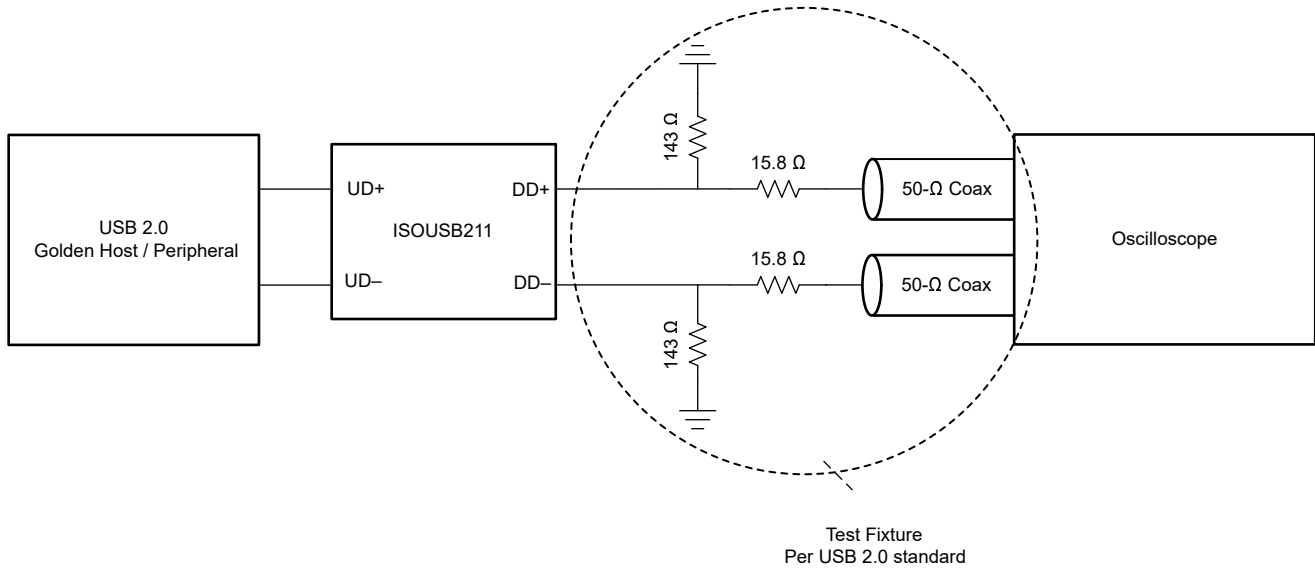

Figure 7-1. Upstream and Downstream Packet Parameter and Eye-Diagram Measurements for HS

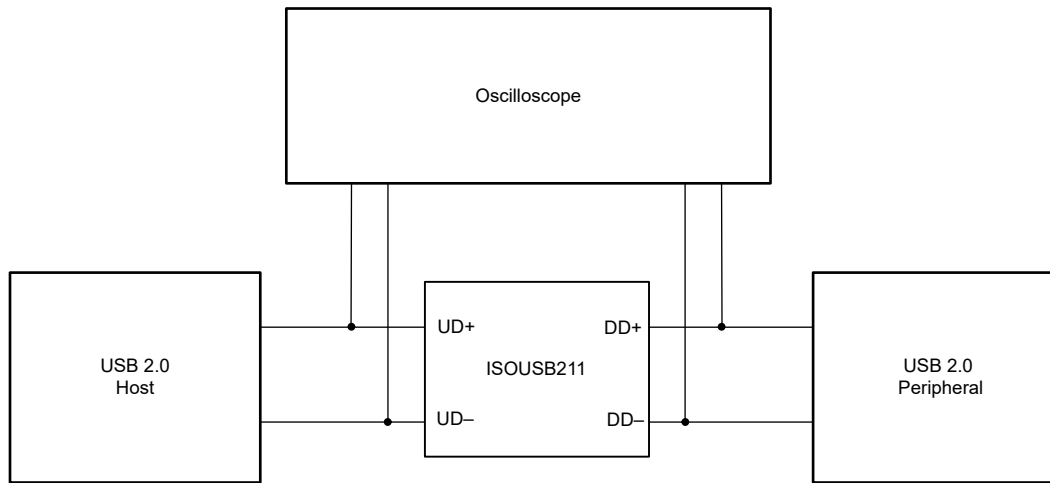

Figure 7-2. Upstream and Downstream Packet Parameter and Eye-Diagram Measurements for LS, FS

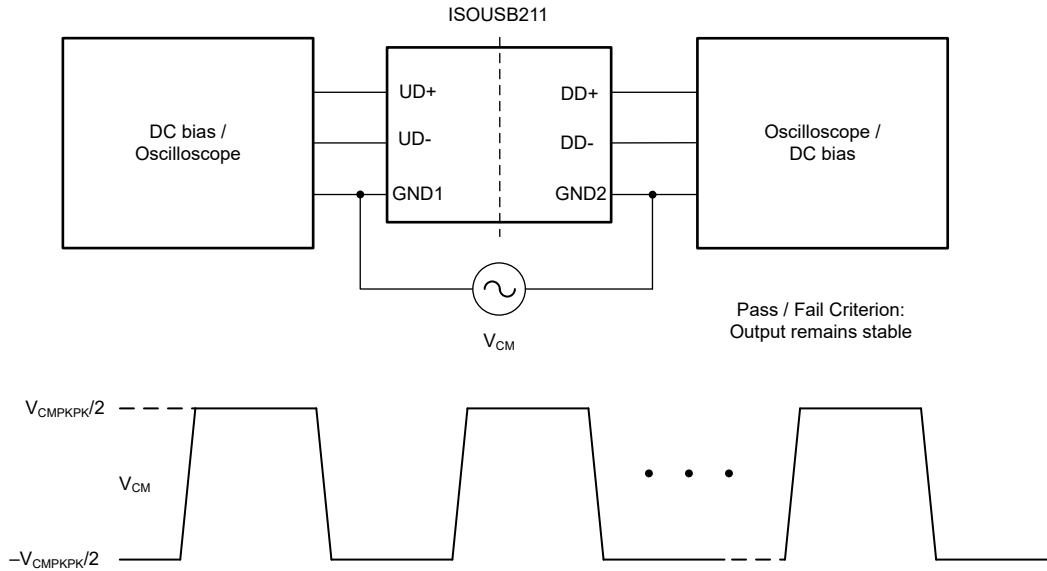

Figure 7-3. Common-Mode Transient Immunity Test Circuit

8 Detailed Description

8.1 Overview

ISOUSB211 is a galvanically-isolated USB2.0 compliant repeater supporting Low Speed (1.5 Mbps), Full Speed (12 Mbps) and High Speed (480 Mbps) signaling rates. The device supports automatic speed and connection detection, reflection of pull-ups/pull-downs, and link power management allowing drop-in USB hub, host, peripheral and cable isolation. Most microcontrollers integrate the USB PHY, and so offer only D+ and D- bus lines as external pins. ISOUSB211 can isolate these pins from the USB bus without needing any other intervention from the microcontroller. The device also supports automatic role reversal - if after disconnect, if a new connect is detected on the Upstream facing port, then the Upstream and Downstream port definitions are reversed. The ISOUSB211 has inbuilt programmable equalization to cancel signal loss caused by board traces, which helps in meeting USB2.0 high-speed TX and RX eye-diagram templates. High Speed (HS) Test Mode entry is also automatically detected, as required by the USB2.0 standard, to enable HS compliance tests.

ISOUSB211 is available in reinforced isolation option with isolation withstand voltage of 5000 V_{RMS} respectively, and with surge test voltage of 12.8 kV_{PK} respectively. The device can operate completely off a 4.25 V to 5.5 V supply (USB VBUS power) or from local 3.3-V and 1.8- supplies, if available, on both side 1 and side 2. This flexibility in supply voltages allows optimization for thermal performance based on power rails available in the system.

8.2 Functional Block Diagram

A simplified functional block diagram of ISOUSB211 is shown in [Figure 8-1](#). The device comprises the following:

1. Transmit and receive circuits and pull-up and pull-down resistors according to the USB standard.
2. Digital logic to handle bi-directional communication, and various state-transitions.
3. Internal LDOs to generate V_{3P3Vx} and V_{1P8Vx} supplies from the V_{BUSx} and V_{CCx} supplies respectively.
4. Galvanic isolation.

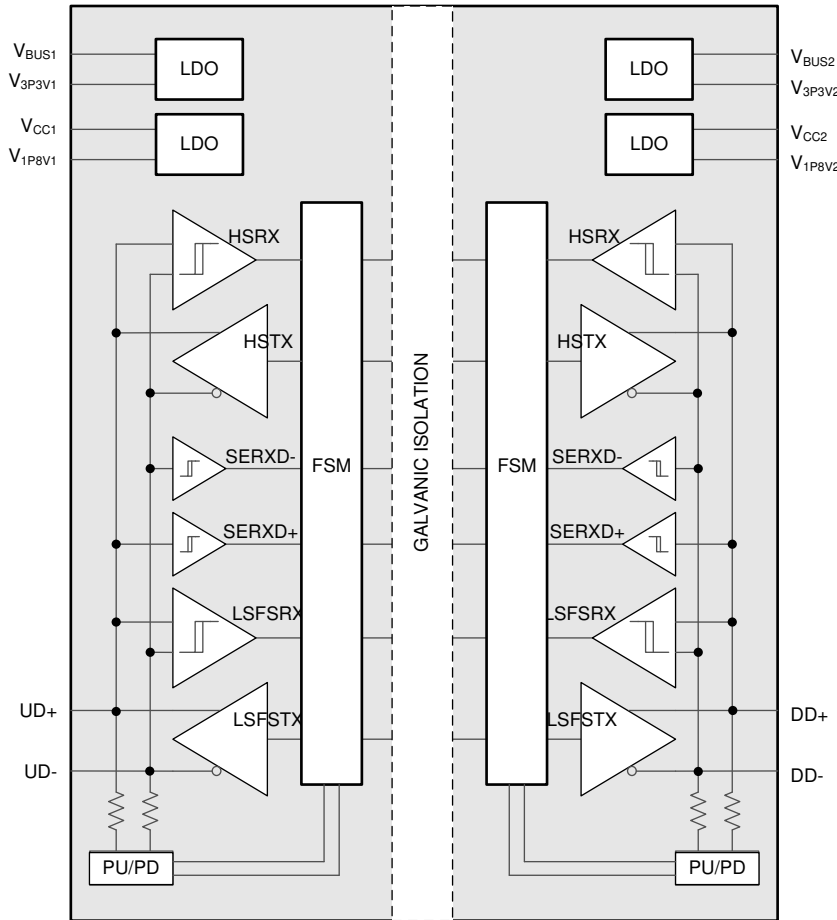

Figure 8-1. ISOUSB211 Simplified Functional Block Diagram

8.3 Feature Description

8.3.1 Power Supply Options

The ISOUSB211 can be powered by connecting a 4.25 V to 5.5 V supply on V_{BUSx} pins, in which case an internal LDO generates V_{3P3Vx} voltage. This option is suitable for the side facing the USB connector, where a 5-V VBUS supply is available. Alternatively, V_{BUSx} and V_{3P3Vx} pins can be shorted together and an external 3.3-V power supply can be connected to both. This second option is suitable for the side facing the microcontroller, where a 5-V supply may not be available.

The ISOUSB211 also needs a 1.8-V supply for operation. A 2.4 V to 5.5 V supply can be connected on V_{CCx} pins, in which case internal LDOs generate the V_{1P8Vx} supplies. In the simplest implementation, V_{CCx} can be connected to the USB VBUS on the side facing the connector, and to the 3.3-V local supply on the side facing the microcontroller. In this implementation, there is power dissipation on the internal LDOs of ISOUSB, which limits the maximum ambient temperature supported by ISOUSB211.

To reduce power dissipation inside the ISOUSB211, an external 1.8-V supply can be connected to both V_{CCx} and V_{1P8Vx} pins shorted together, in which case the internal 1.8-V LDOs of ISOUSB211 are bypassed. In this implementation, some of the power dissipation is transferred to the external 1.8-V supply, and overall higher ambient temperature operation is achieved for the ISOUSB211. If the external 1.8-V supply is an LDO, the effect is to reduce power dissipation inside ISOUSB211, but overall no reduction in system current or power dissipation is achieved. Alternatively, if the external 1.8-V supply is a DC-DC (buck) converter, both system power and ISOUSB211 power dissipation can be reduced.

A third option is to include external resistors between V_{CCx} pins and VBUS and 3.3-V local supplies. These resistors can be accommodated since V_{CCx} pins operate down to 2.4 V. The resistors drop voltage and dissipate

power and serve a similar purpose as external 1.8-V LDOs, that is, reduce power dissipation inside ISOUSB211 and allow higher ambient temperature operation.

Refer to the [Thermal Considerations](#) section for further details on how to optimize ISOUSB211 internal power dissipation according to the maximum ambient temperature required in the system, and for recommendations on external resistors, LDOs and buck converters.

8.3.2 Power Up

Until all power supplies on both sides of ISOUSB211 are above their respective UVLO thresholds, the device ignores any activity on the bus lines on both upstream and downstream side. Once the power supplies are above their UVLO thresholds, the device is ready to respond to activity on the bus lines. When the power supplies on side 1 are up, this is indicated on side 2 by V1OK = High. Similarly, V2OK = High indicates that Side 2 is fully powered up.

8.3.3 Symmetric Operation, Dual-Role Port and Role-Reversal

ISOUSB211 supports symmetric operation. Normally, UD+ and UD- are upstream facing ports and connect to a host or hub. DD+ and DD- are downstream facing ports and connect to a peripheral. However, it is also possible to connect UD+ and UD- to a peripheral and DD+ and DD- to a host or hub. Whichever side sees a connect first (D+ or D- pulled up to 3.3 V) becomes the downstream facing side. This feature enables implementation of dual-role port (for eg. Type-C dual-role port) and role-reversal (for eg. OTG Host Negotiation Protocol - HNP). Refer to [How to Implement an Isolated USB 2.0 High-Speed, Type-C® DRP](#) application note for details. In the rest of this document, DD+/DD- are treated as downstream facing ports, and UD+/UD- as upstream facing ports, but the various operations and features described are equally applicable if this assignment is swapped.

8.3.4 Connect and Speed Detection

When there is no peripheral device connected to the downstream side of ISOUSB211, internal 15 kΩ pull-down resistors on DD+ and DD- pins pull the bus lines to zero, creating an SE0 state. When either the DD+ or DD- lines is pulled up higher than the V_{IH} threshold, for a time period higher than $T_{FILTCONN}$, the ISOUSB211 device treats this as a connect. The ISOUSB211 device configures internal pull-up on the upstream side to match the pull-up detected on the downstream side. After connect is detected, the ISOUSB211 device waits for a reset to be asserted by the host/hub on the upstream side. Depending on whether DD+ or DD- is pulled up at the start of reset, the speed of the ISOUSB211 repeater is set. Once set, the speed of the repeater can only be changed after a power down or disconnect event.

A high-speed (HS) capable device is attached to the ISOUSB211 device would proceed to perform high-speed handshake using chirp signaling as specified in the USB2.0 standard. This would be followed by chirp signals from the host. The ISOUSB211 device reflects these chirp signals across the barrier, including HS idle (SE0) states from downstream to upstream and vice versa. Upon successful completing of the HS handshake ISOUSB211 speed is set to High speed. Once set to high-speed, the speed of the repeater can only be changed after power down, HS disconnect event, or if the peripheral or host/hub do not perform HS handshake after a reset.

8.3.5 Disconnect Detection

When in Full-speed (FS) and Low-speed (LS) modes, disconnection of a peripheral is indicated when the host/hub is not driving any signal on the upstream side, and when the downstream bus is in the SE0 state (Both DD+ and DD- are below the V_{IL} threshold) for a time period higher than T_{DDIS} . Upon disconnect detection in FS and LS modes, the ISOUSB211 device removes the pull-up resistor from the upstream side, thus allowing the upstream UD+ and UD- lines to discharge to zero. The ISOUSB211 then waits for the next connect event to occur.

When in High Speed (HS) mode, if the ISOUSB211 detects a continuous period of no transitions lasting T_{HSDIS} , the device samples the DD+ and DD- lines using the HS Disconnect detector. If the input differential voltage crosses V_{HSDSC} during T_{HSDIS} , the repeater removes the HS termination from both the downstream and upstream terminals and transitions to a disconnect state. The ISOUSB211 then waits for the next connect event to occur.

8.3.6 Reset

The ISOUSB211 device detects Reset assertion (prolonged SE0 state) on its upstream facing side, and transmits the same to the downstream facing side. In HS state, an extended HS idle state can be the beginning of reset, or an entry into L2 Power Management state. ISOUSB211 is able to make the distinction between the two, and accordingly either continue to drive HS idle (same as reset) on the downstream side or transition to the L2 suspend state.

8.3.7 LS/FS Message Traffic

The ISOUSB211 device monitors the state of the bus on both upstream and downstream sides. The direction of communication is set by which side transitions from the LS/FS idle state first (J to K transition). After that, data is transferred digitally across the barrier, and reconstructed on the other side. Data transmission continues till either an End-of-Packet (EOP) or a long idle is seen. At this point, the ISOUSB211 device tri-states its LS/FS transmitters, and waits for the next transition from the LS/FS idle state.

8.3.8 HS Message Traffic

The ISOUSB211 device monitors the state of the bus on both upstream and downstream sides. The direction of communication is set by which side transitions from the HS idle state first. Transition from HS idle state to valid HS data is detected by the HS Squelch Detector. After that, data is transferred digitally across the barrier, and reconstructed on the other side. Data transmission continues till the bus returns to HS idle state, also indicated by the HS Squelch Detector. At this point, the ISOUSB211 device tri-states its HS transmitters, and waits for the next transition from the HS idle state.

8.3.9 Equalization and Pre-emphasis

The ISOUSB211 has inbuilt programmable receive equalization and transmit pre-emphasis to cancel signal loss caused by board traces, which helps in meeting USB2.0 high-speed TX and RX eye-diagram templates. These settings are controlled by EQ11 and EQ10 on side 1 and EQ21 and EQ20 on side 2. The EQxx pins can be connected to ground, connected to 3.3-V supply or left floating, together creating 9 different equalization levels. EQ11 and EQ10 can be chosen based on the length of D+/D- board trace and corresponding channel loss estimated on side 1, and similarly EQ21 and EQ20 for side 2. Typical 45-Ohm trace in FR4 has about 0.15 dB/inch for 480 Mbps signaling. Further adjustments to the EQ settings can be made by observing the transmit eye-diagram at the connector. If the trace lengths are very small, no equalization may be needed, and the EQxx pins can be connected to ground.

ISOUSB211 samples EQxx pins only at power up, so it is not recommended to change the EQxx settings on the fly after power up.

8.3.10 L2 Power Management State (Suspend) and Resume

The ISOUSB211 device supports Suspend low power state, also called L2 state in the USB 2.0 Link Power Management engineering change notice (ECN). Suspend mode is detected if the bus stays in the LS/FS/HS idle state for more than 3 ms. When Suspend is detected from LS and FS idle state, the ISOUSB211 continues in the LS or FS idle state, at the same time reducing internal power consumption. If Suspend is detected from HS idle state, the ISOUSB211 detects the DS port transition to FS idle state (FS J), and reflects this upstream, while disabling all high-speed circuits to reduce power consumption. The transition to the L2 low-power mode is completed within 10 ms.

Exit from L2 occurs through either Resume signaling from the host, on the upstream facing side of ISOUSB211, or Remote Wake signaling from the peripheral on the downstream facing side of ISOUSB211 followed by Resume signaling from the host/hub on the upstream facing side. Start of Resume or Wake are signaled by a 'K' state by the host or the device respectively. The end of resume is signalled by the host by driving two low-speed bit times of SE0 followed by a 'J' state. If the port was operating in high speed before entering the low power state, end of resume is signaled by the host by transitioning to the high speed idle state. ISOUSB211 is able to replicate the resume and wake signaling appropriately both upstream and downstream. After Resume/Wake signaling the device returns to LS, FS or HS idle state depending on the state it was in before entering the L2 state.

8.3.11 L1 Power Management State (Sleep) and Resume

The ISOUSB211 device supports the additional L1 or Sleep low power state defined in the USB 2.0 Link Power Management ECN. When L1 entry is detected from the LS and FS idle state, the ISOUSB211 continues in the LS or FS idle state, at the same time reducing internal power consumption. If L1 entry is detected from HS idle state, the ISOUSB211 disables all high-speed circuits to reduce power consumption. The transition to the L1 low-power mode is completed within 50 μ s.

Exit from L1 occurs through either Resume signaling from the host, on the upstream facing side of ISOUSB211, or Remote Wake signaling from the peripheral on the downstream facing side of ISOUSB211 followed by Resume signaling from the host/hub on the upstream facing side. Start of Resume or Wake are signaled by a 'K' state by the host or the device respectively. The end of resume is signalled by the host by driving two low-speed bit times of SE0 followed by a 'J' state. If the port was operating in high speed before entering the low power state, end of resume is signaled by the host by transitioning to the high speed idle state. ISOUSB211 is able to replicate the K signaling appropriately both upstream and downstream. After Resume/Wake signaling the device returns to LS, FS or HS idle state depending on the state it was in before entering the L1 state.

8.3.12 HS Test Mode Support

USB2.0 standards needs test mode support, where the host/hub or peripheral is expected to enter High Speed test-modes based on commands received. ISOUSB211 is able to automatically detect test mode entry to enable HS compliance tests.

8.3.13 CDP Advertising

The ISOUSB211 device supports CDP advertising on both downstream and upstream facing side according to Battery Charger standard BC 1.2. CDP advertising is useful when isolating a host or hub, to indicate to the connected peripheral that the port is capable of supplying 1.5 A of current on VBUS. CDP advertising can be enabled by connecting the downstream side CDPENX pin to ground (active low).

8.4 Device Functional Modes

[Function Table](#) lists the functional modes for the ISOUSB211 device.

Table 8-1. Function Table

SIDE 1 SUPPLY V_{BUS1} , V_{3P3V1} V_{CC1} , V_{1P8V1} ⁽¹⁾	BUS1 (UD+, UD-)	SIDE 2 SUPPLY V_{BUS2} , V_{3P3V2} V_{CC2} , V_{1P8V2}	BUS2 (DD+, DD-)	COMMENTS
Powered	Active	Powered	Active	When both sides are powered, the state-of the bus is reflected correctly from upstream to downstream and vice-versa.
Powered	15-k Ω PD	Powered	15-k Ω PD	Disconnected state is presented on both upstream and downstream
Powered	15-k Ω PD	Unpowered	Z	If a side is not powered, the bus lines on that side are in high-impedance state.
Unpowered	Z	Powered	15-k Ω PD	
Unpowered	Z	Unpowered	Undetermined	

- (1) Powered = $(V_{BUSx} \geq UV_{(VBUSx)}) \parallel (V_{BUSx} = V_{3P3Vx} \geq UV_{(V3P3Vx)})$ & $(V_{CCx} \geq UV_{(VCCx)}) \parallel (V_{CCx} = V_{1P8Vx} \geq UV_{(V1P8Vx)})$;
 Unpowered = $(V_{BUSx} < UV_{(VBUSx)})$ & $(V_{3P3Vx} < UV_{(V3P3Vx)})$ & $(V_{CCx} < UV_{(VCCx)})$ & $(V_{1P8Vx} < UV_{(V1P8Vx)})$; X = Irrelevant; H = High level; L = Low level; Z = High impedance

9 Power Supply Recommendations

0.1 μF capacitors are recommended to be placed very close to V_{3P3Vx} pins to GNDx. 1- μF capacitors are recommended to be placed very close to V_{BUSx} pins to GNDx. 2- μF , 0.1- μF , and 10-nF capacitors are recommended to be placed between V_{1P8Vx} and GNDx, between pins 4 and 3, between pins 25 and 26, between pins 11 and 12, and between pins 25 and 26 respectively, as close to the device as possible. Place the lower value capacitors closer to the IC. If V_{CCx} pins are connected through resistors as shown in [Example Configuration 3](#) 1- μF capacitors are recommended to be placed between V_{CCx} (pins 5, 24) and GNDx (pins 3, 26), as close to the device as possible, with higher priority being accorded to the capacitors on V_{1P8Vx} pins.

These decoupling capacitor recommendations are irrespective of whether the 3.3 V and 1.8 V supplies are provided externally or generated using internal LDOs.

Refer to the [Section 11.1.1](#) section for recommended placement of the decoupling capacitors. Small footprint capacitors (0402/0201) are recommended so that these may be placed very close to the supply pins and corresponding ground pins on the top layer without the use of vias. The capacitors on V_{1P8Vx} supplies are higher in priority when considering placement close to the IC.

While isolating a host/hub or bus-powered peripherals, isolated power is needed and can be generated with the help of a transformer driver such as TI's [SN6505B](#). For such applications, detailed power supply design, and transformer selection recommendations are available in the [SN6505 Low-Noise 1-A Transformer Drivers for Isolated Power Supplies data sheet](#). If CDP functionality is enabled while isolation host/hub, the isolated power supply must be capable of delivering 1.5 A on VBUS.

10 Application and Implementation

Note

Information in the following applications sections is not part of the TI component specification, and TI does not warrant its accuracy or completeness. TI's customers are responsible for determining suitability of components for their purposes. Customers should validate and test their design implementation to confirm system functionality.

10.1 Typical Application

10.1.1 Isolated Host or Hub

Figure 10-1 shows an application for isolating a host or a hub using ISOUSB211. In this example, on the microcontroller side, V_{3P3V1} and V_{BUS1} are together connected to an external 3.3-V supply. The V_{1P8V1} supply is generated using the internal 1.8-V LDO by providing 3.3-V supply to V_{CC1} . On the connector side, the VBUS from the USB connector is connected to V_{BUS2} and the V_{3P3V2} supply is generated using the internal 3.3-V LDO. V_{CC2} and V_{1P8V2} are together connected to an external 1.8-V supply derived from VBUS. Please refer to [Thermal Considerations](#) for options on optimizing power dissipation inside ISOUSB211 as required.

Decoupling capacitors are placed next to ISOUSB211 according to the recommendations provided in the [Power Supply Recommendations](#) section. An isolated DC-DC converter (such as the SN6505) is to provide power to the VBUS using the 3.3-V local supply. Note that, for a host or hub, the USB standard requires a 120- μ F capacitor to be placed on the VBUS so as to be able provide in-rush current when a downstream peripheral is attached. In addition, a 100-nF capacitor is recommended close to the VBUS pin to handle transient currents.

ESD diodes with low capacitance and low dynamic resistance, such as PESD5V0C1USF, may be placed on D+ and D- lines. A ferrite bead, with dc resistance less than 100 m Ω , may be optionally placed between VBUS pin of the connector and the V_{BUS} pin of ISOUSB211, as shown in the figure, to suppress transients such as ESD.

If the isolated power supply used is capable of providing >1.5 A current on the VBUS, the port can be configured as a CDP port according to Battery Charger specification BC 1.2. To do this, the CDPENZ2 pin of ISOUSB211 must be connected to ground as shown. Under this condition ISOUSB211 responds to BC 1.2 signaling from a connected peripheral indicating to the peripheral that the port is capable of supply 1.5-A current on VBUS.

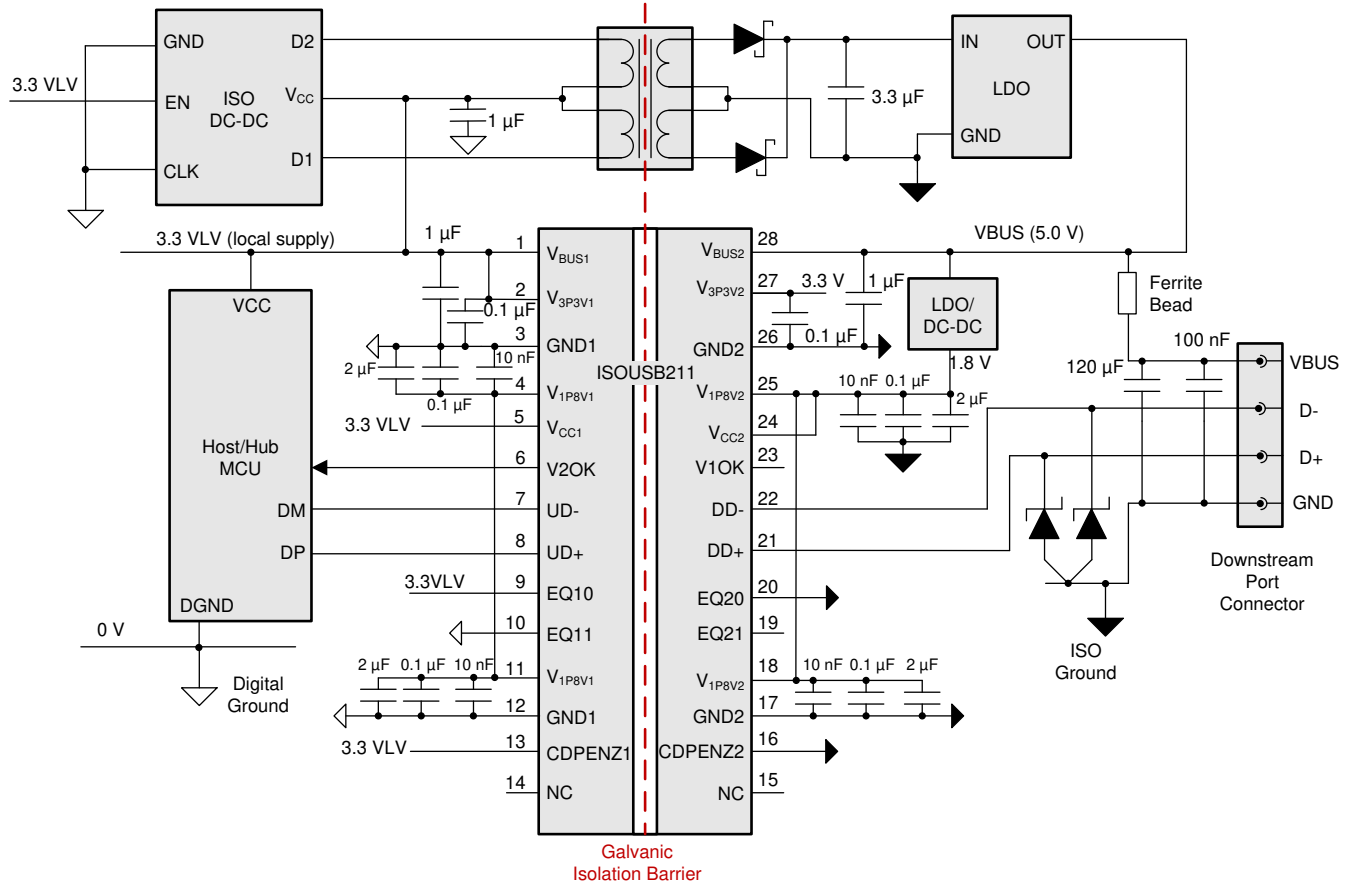

Figure 10-1. Isolated Host or Hub with ISOUSB211

10.1.2 Isolated Peripheral - Self-Powered

Figure 10-2 shows an application for isolating a self-powered peripheral using ISOUSB211. In this example, on the microcontroller side, V_{3P3V2} and V_{BUS2} are together connected to an external 3.3-V supply. The V_{1P8V2} supply is generated using the internal 1.8-V LDO by providing 3.3-V supply to V_{CC1} . On the connector side, the VBUS from the USB connector is connected to V_{BUS1} and the V_{3P3V1} supply is generated using the internal 3.3-V LDO. V_{CC1} and V_{1P8V1} are together connected to an external 1.8-V supply derived from VBUS. Please refer to [Thermal Considerations](#) for options on optimizing power dissipation inside ISOUSB211 as required.

Decoupling capacitors are placed next to ISOUSB211 according to the recommendations provided in the [Power Supply Recommendations](#) section. Note that the USB standard requires that, for a peripheral, the total capacitor value on VBUS must be less than 10- μ F. However, a total of at least 5- μ F capacitance is recommended on VBUS. A 100-nF capacitor is recommended close to the VBUS pin to handle transient currents.

ESD diodes with low capacitance and low dynamic resistance, such as PESD5V0C1USF, may be placed on D+ and D- lines. A ferrite bead, with dc resistance less than 100 mΩ, may be optionally placed between VBUS pin of the connector and the V_{BUS} pin of ISOUSB211, as shown in the figure, to suppress transients such as ESD.

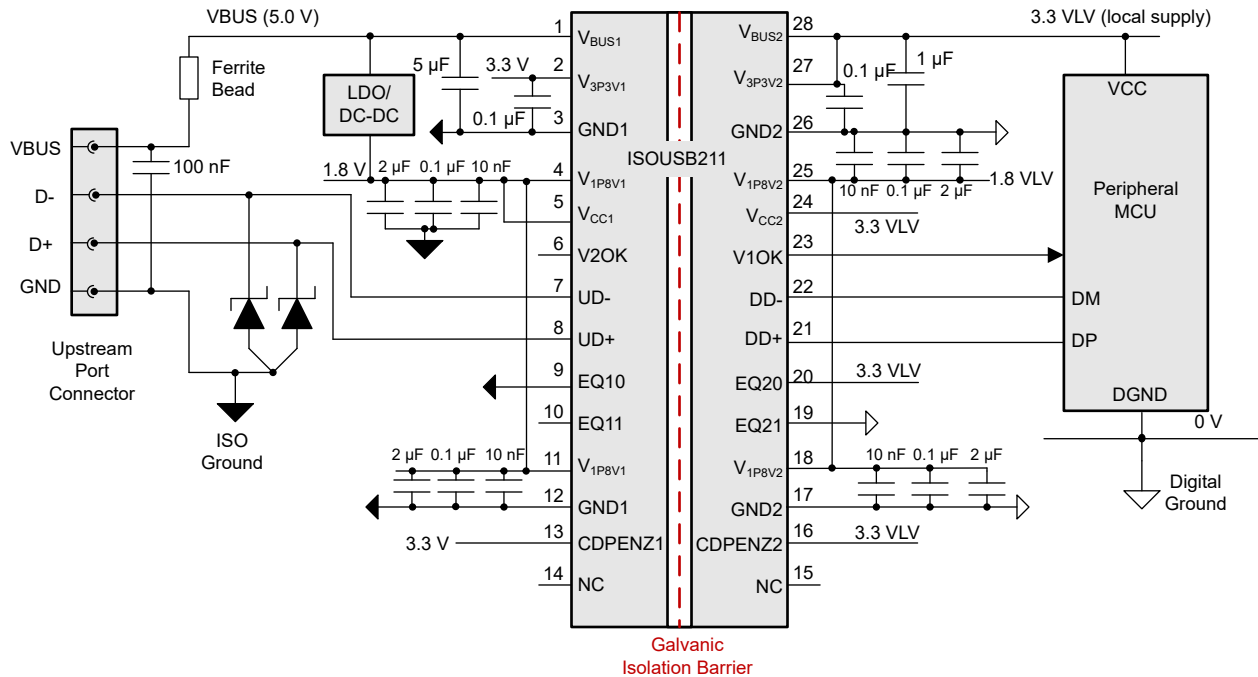

Figure 10-2. Isolated Self-Powered Peripheral with ISOUSB211

10.1.3 Isolated Peripheral - Bus-Powered

Figure 10-3 shows an application for isolating a self-powered peripheral using ISOUSB211. In this example, an isolated DC-DC converter (for example: SN6505) is used to create a 3.3-V local supply while deriving power from the USB VBUS. On the microcontroller side, V_{3P3V2} and V_{BUS2} are together connected to an external 3.3-V supply. The V_{1P8V2} supply is generated using the internal 1.8-V LDO by connecting the 3.3-V local supply to V_{CC1}. On the connector side, the VBUS from the USB connector is connected to V_{BUS1} and the V_{3P3V1} supply is generated using the internal 3.3-V LDO. V_{CC1} and V_{1P8V1} are connected together connected to an external 1.8-V supply derived from VBUS. Please refer to [Thermal Considerations](#) for options on optimizing power dissipation inside ISOUSB211 as required.

Decoupling capacitors are placed next to ISOUSB211 according to the recommendations provided in the [Power Supply Recommendations](#) section. Note that the USB standard requires that, for a peripheral, the total capacitor value on VBUS, including any decoupling capacitors reflected from the secondary side through the isolated DC-DC converter, must be less than 10-μF. However, a total of at least 5-μF capacitance is recommended on VBUS. A 100-nF capacitor is recommended close to the VBUS connector to handle transient currents.

ESD diodes with low capacitance and low dynamic resistance, such as PESD5V0C1USF, may be placed on D+ and D- lines. A ferrite bead, with dc resistance less than 100 mΩ, may be optionally placed between VBUS pin of the connector and the V_{BUS} pin of ISOUSB211, as shown in the figure, to suppress transients such as ESD.

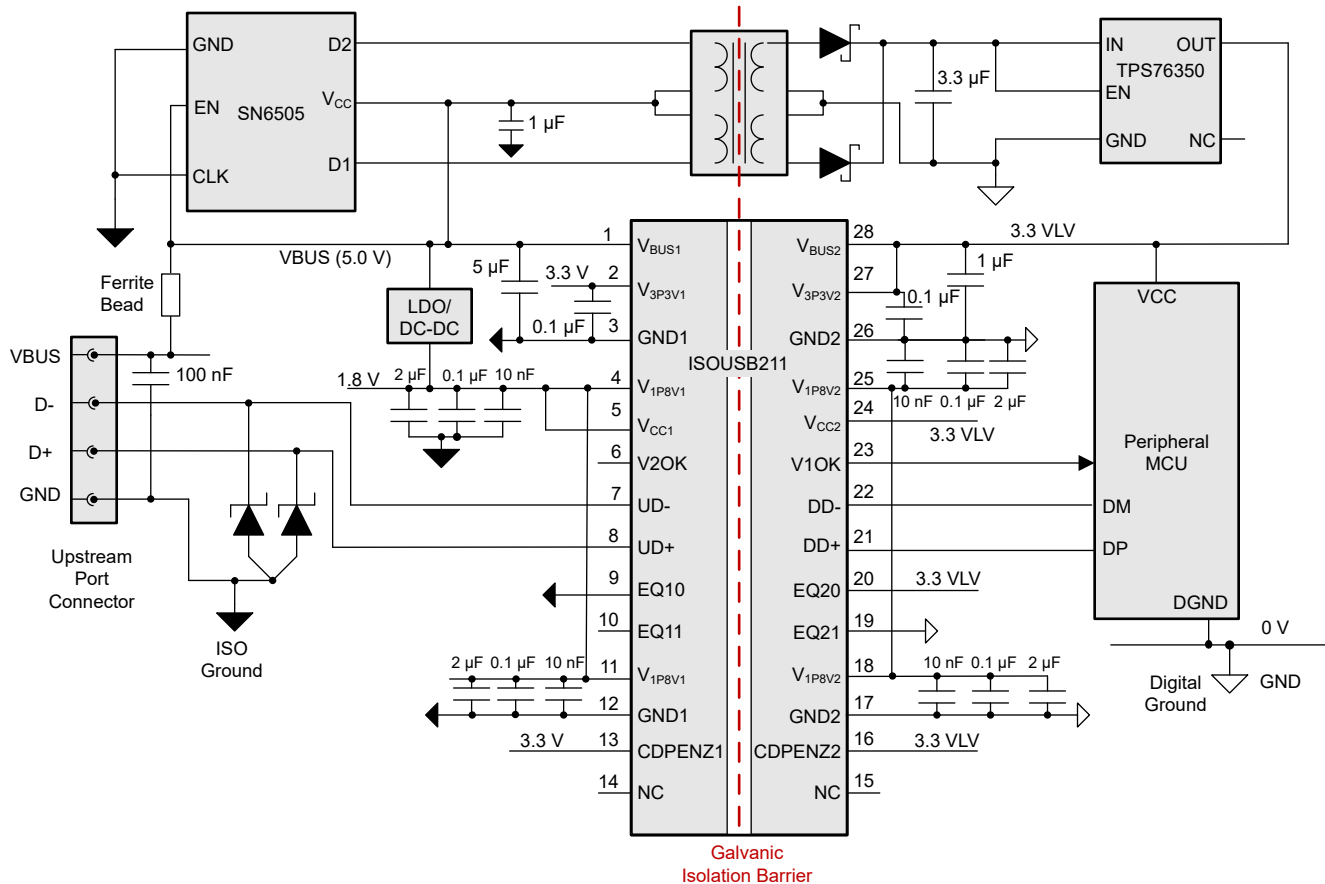

Figure 10-3. Isolated Bus-Powered Peripheral using ISOUSB211

10.1.4 Application Curve

10.1.4.1 Insulation Lifetime

Insulation lifetime projection data is collected by using industry-standard Time Dependent Dielectric Breakdown (TDDB) test method. In this test, all pins on each side of the barrier are tied together creating a two-terminal device and high voltage applied between the two sides; See Figure 10-4 for TDDB test setup. The insulation breakdown data is collected at various high voltages switching at 60 Hz over temperature. For reinforced insulation, VDE standard requires the use of TDDB projection line with failure rate of less than 1 part per million (ppm). Even though the expected minimum insulation lifetime is 20 years at the specified working isolation voltage, VDE reinforced certification requires additional safety margin of 20% for working voltage and 50% for lifetime which translates into minimum required insulation lifetime of 30 years at a working voltage that's 20% higher than the specified value.

Figure 10-5 shows the intrinsic capability of the isolation barrier to withstand high voltage stress over its lifetime. Based on the TDDB data, the intrinsic capability of the insulation is 1500 V_{RMS} with a lifetime of 169 years. Other factors, such as package size, pollution degree, material group, etc. can further limit the working voltage of the component. The working voltage of DP-28 package is specified upto 1500 V_{RMS}. At the lower working voltages, the corresponding insulation lifetime is much longer than 169 years.

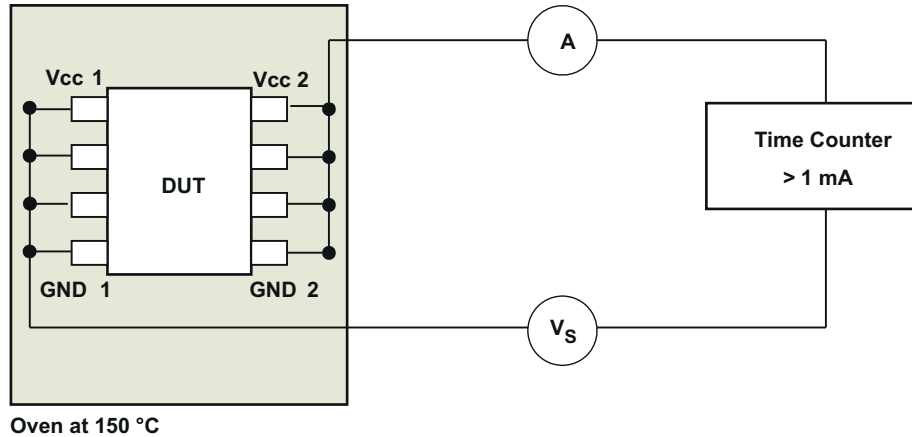

Figure 10-4. Test Setup for Insulation Lifetime Measurement

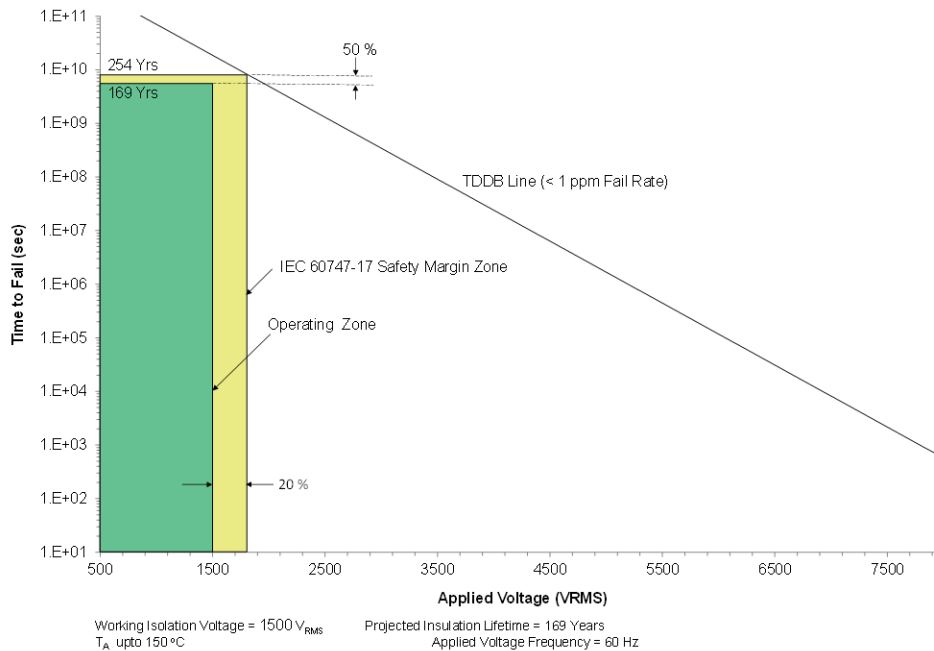

Figure 10-5. Insulation Lifetime Projection Data

10.2 Meeting USB2.0 HS Eye-Diagram Specifications

The USB2.0 standards specifies TX and RX eye-diagram templates that must be met at the connector. The horizontal eye-opening achieved at the connector is a combination of the performance at the microcontroller, the additive jitter of the ISOUSB211, and the inter-symbol interference resulting from the insertion loss of D+/D- board traces. For best performance, it is recommended to minimize the length of D+/D- board traces from the MCU to ISOUSB211, and from ISOUSB211 to the connector. Vias and stubs on D+/D- lines must be avoided.

The ISOUSB211 has inbuilt programmable receive equalization and transmit pre-emphasis to cancel signal loss caused by board traces, which helps in meeting USB2.0 high-speed TX and RX eye-diagrams. EQ11 and EQ10 can be chosen based on the length of D+/D- board traces and corresponding channel loss estimated on side 1, and similarly EQ21 and EQ20 for side 2. The EQxx pins can be connected to ground, connected to 3.3-V supply or left floating, together creating 9 different equalization levels.

Typical 45-Ohm traces in FR4 have an insertion loss of about 0.15 dB/inch for 480 Mbps signaling. This number can be used to arrive at an estimate for the amount of Equalization/Pre-emphasis needed and the corresponding EQ settings. Further adjustments to the EQxx settings can be made by observing the transmit eye-diagram at

the connector, and choosing the setting that gives the best eye-opening. Choosing the right setting for the transmit path will also result in an optimum performance for the receive path. Refer to [Compensate for Channel Loss with Equalizer Settings on High-Speed USB Isolators](#) application note for details. If the trace lengths are very small, no equalization may be needed, and the EQxx pins can be connected to ground.

10.3 Thermal Considerations

ISOUSB211 offers different power supply input options, including internal LDOs, that can be used to optimize thermal performance in HS mode. If the 3.3-V and 1.8-V supplies are supplied using external regulators, the power dissipated inside the ISOUSB chip is lower. The internal power dissipated, when taken with the junction-to-air thermal resistance defined in the Thermal Information table can be used to determine the junction temperature for a given ambient temperature. The junction temperature must not exceed 150°C. This section describes different power supply configurations for ISOUSB211 and explains how the power dissipated inside ISOUSB211 and the internal temperature rise can be calculated in each case.

For optimal thermal performance, connect small ground planes to the GNDx pins, and connect these planes to the ground layer with multiple vias as shown in [Layout Example](#).

10.3.1 V_{BUS} / V_{3P3V} Power

If V_{BUS} is connected to external 5.0-V supply, with V_{3P3V} generated through an internal LDO, the power dissipated is $V_{BUSx} \times I_{VBUSx}$.

If V_{BUSx} and V_{3P3Vx} are shorted together and connected to an external 3.3 V supply, the power dissipated due to this supply is $V_{3P3Vx} \times I_{3P3Vx}$.

10.3.2 V_{CCx} / V_{1P8Vx} Power

If V_{CCx} is connected to external 2.4 to 5.0-V supply, with V_{1P8Vx} generated through the internal 1.8-V LDO, the power dissipated is $V_{CCx} \times I_{VCCx}$.

If V_{CCx} and V_{1P8Vx} are shorted together and connected to an external 1.8-V supply, the power dissipated due to this supply is $V_{1P8Vx} \times I_{1P8Vx}$.

10.3.3 Example Configuration 1

In the application example shown in [Figure 10-6](#), ISOUSB211 is powered using USB V_{BUS} on the connector side, and a local 3.3-V digital supply on the microcontroller side. No other external regulators or power supplies are used.

In this scenario, the total power consumption inside ISOUSB211 from both sides taken together is:

$$V_{BUS1} \times I_{VBUS1} + V_{BUS1} \times I_{VCC1} + V_{3P3V2} \times I_{3P3V2} + V_{3P3V2} \times I_{VCC2}$$

Assuming 5.25 V as the maximum value of V_{BUS1}, and 3.5 V as the maximum value of the 3.3-V local supply, the internal power dissipation is calculated as:

$$5.25 \text{ V} \times 13.5 \text{ mA} + 5.25 \text{ V} \times 96 \text{ mA} + 3.5 \text{ V} \times 13.5 \text{ mA} + 3.5 \text{ V} \times 96 \text{ mA} = 960 \text{ mW}$$

Since the junction-to-air thermal resistance is 44.2°C/W, this power dissipation results in a 42.5°C internal temperature rise. Ambient temperature up to 107°C can be supported for this configuration.

This configuration offers the simplest implementation, but the ambient temperature supported is lower than other configurations.

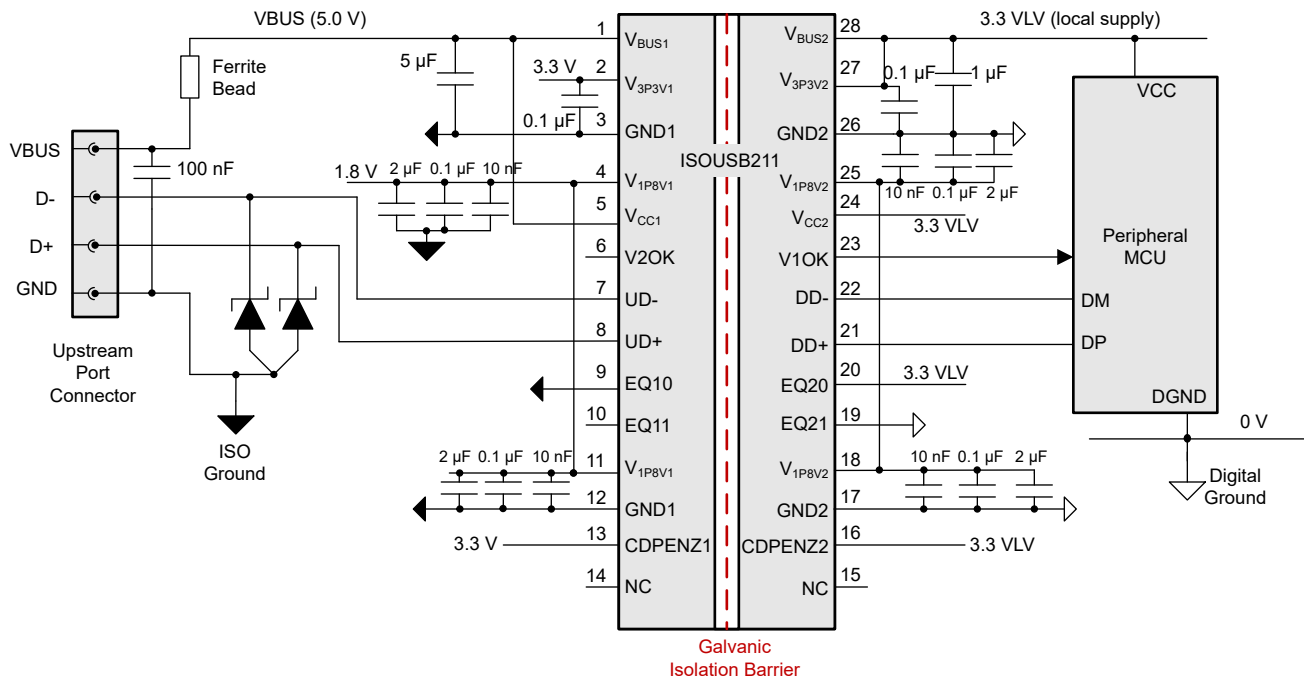

Figure 10-6. Using ISOUSB211 without External 1.8-V Regulators

10.3.4 Example Configuration 2

In the application example shown in [Figure 10-7](#), ISOUSB211 is powered using USB VBUS on the connector side, and a local 3.3-V digital supply on the microcontroller side to generate V_{3P3Vx} . An external LDO or DC-DC buck converter is used to generate V_{1P8Vx} on both sides.

In this scenario, the total power consumption from both sides taken together is:

$$V_{BUS1} \times I_{VBUS1} + V_{1P8V1} \times I_{1P8V1} + V_{3P3V2} \times I_{3P3V2} + V_{1P8V2} \times I_{1P8V2}$$

Assuming 5.25 V as the maximum value of VBUS, and 1.89 V as the maximum value of the external 1.8-V power supply, the internal power dissipation is calculated as

$$5.25 \text{ V} \times 13.5 \text{ mA} + 1.89 \text{ V} \times 96 \text{ mA} + 3.5 \text{ V} \times 13.5 \text{ mA} + 1.89 \text{ V} \times 96 \text{ mA} = 481 \text{ mW}$$

Since the junction-to-air thermal resistance is 44.2°C/W, this power dissipation results in a 22°C internal temperature rise. Ambient temperature up to 128°C can be supported for this configuration.

[TLV741P](#) and [TLV62568](#) are examples of low-cost LDO and buck converter respectively that may be used in this application. Both options reduce the power dissipation in ISOUSB211. However, the buck converter additionally reduces power dissipation at the system level, and also the current drawn from VBUS and local 3.3-V supplies.

This configuration offers the lowest power dissipation and the highest ambient temperature operation using external regulators.

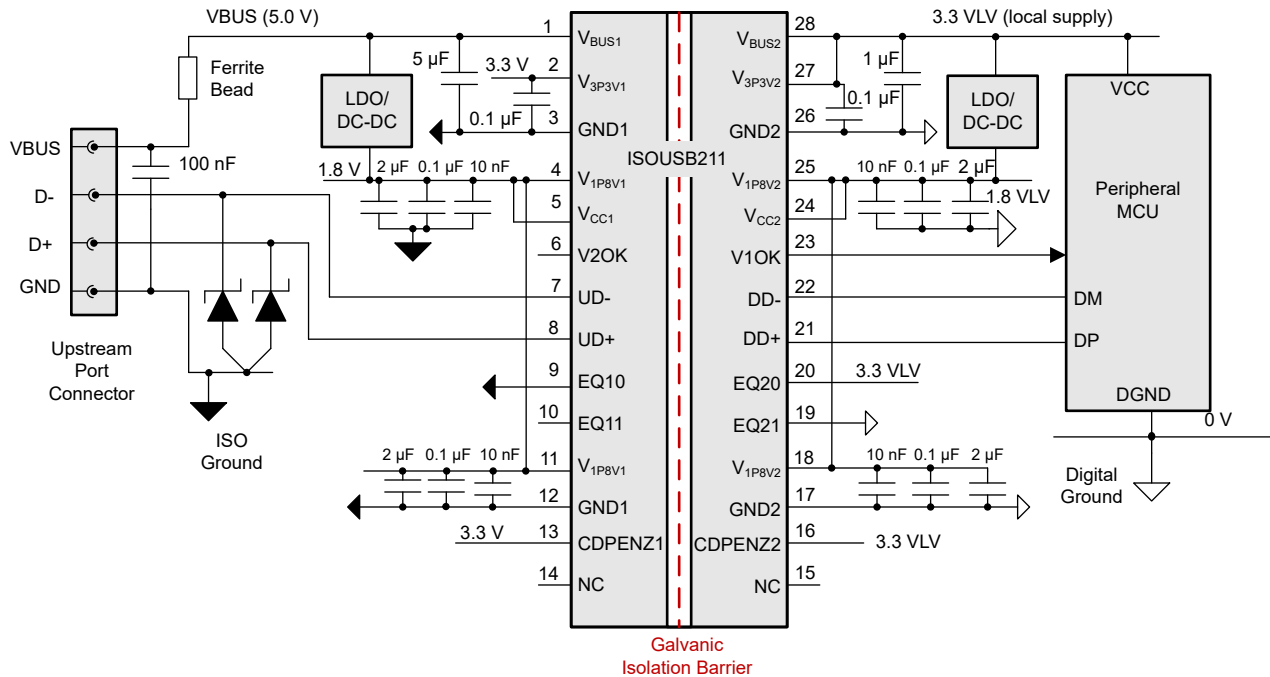

Figure 10-7. Using ISOUSB211 with 1.8-V supplied with External Regulators

10.3.5 Example Configuration 3

In the application example shown in Figure 10-8, ISOUSB211 is powered using USB VBUS on the connector side, and a local 3.3-V digital supply on the microcontroller side to generate V_{3P3Vx} . The internal LDOs are used to generate V_{1P8Vx} on both sides like in Example Configuration 1. However, the V_{CC1} and V_{CC2} are connected to VBUS and 3.3 VLV, not directly like in Example Configuration 1, but through resistors R1 (20 Ω , 250 mW) and R2 (5 Ω , 50 mW) respectively.

The external resistors drop voltage, and dissipate power, helping reduce the power dissipation within ISOUSB211, and the corresponding temperature rise. The resistor values are decided keeping in mind that the V_{CCx} voltage can be as low as 2.4 V. Additional 1- μ F capacitors are needed on V_{CCx} pins.

In this scenario, the total power consumption inside the IC from both sides taken together is:

$$V_{BUS1} \times I_{VBUS1} + V_{BUS1} \times I_{VCC1} - 20 \Omega \times I_{VCC1} \times I_{VCC1} + V_{3P3V2} \times I_{3P3V2} + V_{3P3V2} \times I_{VCC2} - 5 \Omega \times I_{VCC2} \times I_{VCC2}$$

Assuming 5.25 V as the maximum value of VBUS, and 3.5 V as the maximum value of the 3.3-V local supply, the internal power dissipation is calculated as

$$5.25 \text{ V} \times 13.5 \text{ mA} + 5.25 \text{ V} \times 96 \text{ mA} - 20 \Omega \times 96 \text{ mA} \times 96 \text{ mA} + 3.5 \text{ V} \times 13.5 \text{ mA} + 3.5 \text{ V} \times 96 \text{ mA} - 5 \Omega \times 96 \text{ mA} \times 96 \text{ mA} = 728 \text{ mW}.$$

Since the junction-to-air thermal resistance is 44.2°C/W, this power dissipation results in a 33°C internal temperature rise. Ambient temperature up to 117°C can be supported for this configuration.

ISOUSB211

SLLSFC5C – NOVEMBER 2021 – REVISED JANUARY 2023

This configuration offers a middle path between [Example Configuration 1](#) and [Example Configuration 2](#), achieving lower temperature rise, and higher ambient temperature operation, with the addition of only two resistors and two capacitors.

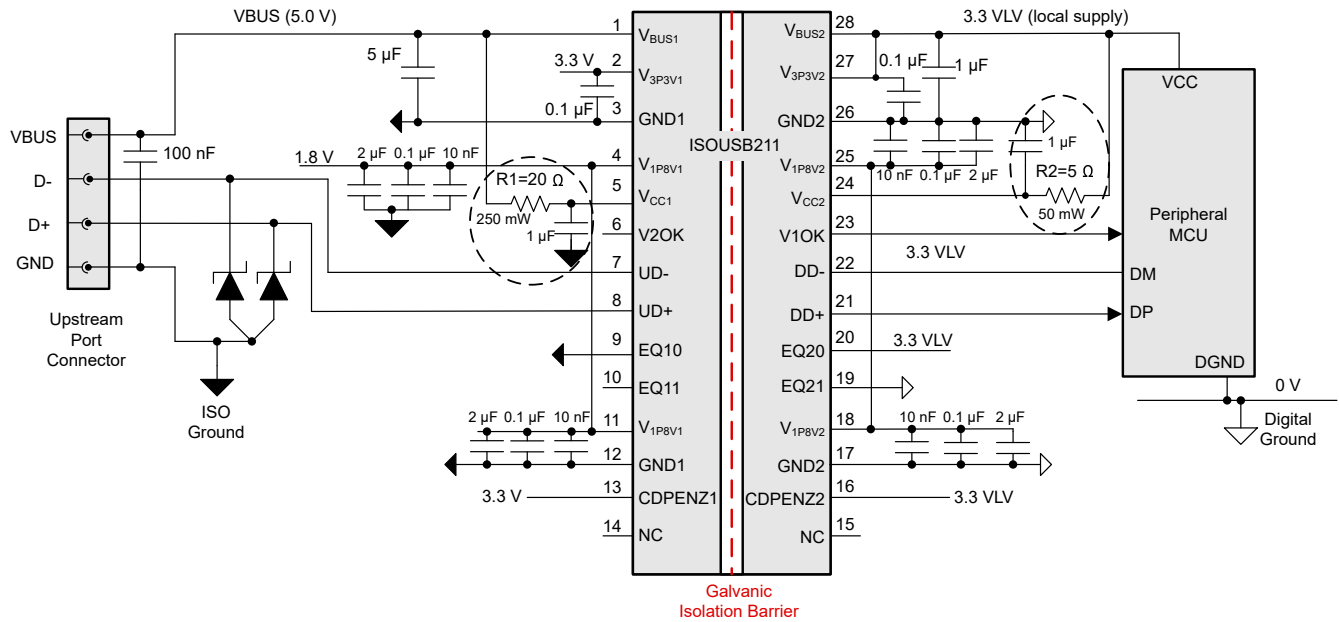

Figure 10-8. Using ISOUSB211 with Resistors in series with V_{CCx} pins

11 Layout

11.1 Layout Guidelines

Three layers are sufficient to accomplish a low EMI PCB design. Layer stacking should be in the following order (top-to-bottom): high-speed signal layer, ground plane, optional power layer, and low-frequency signal layer.

- Routing the high-speed traces on the top layer avoids the use of vias (and the introduction of their inductances) and allows for clean interconnects between the isolator and the transmitter and receiver circuits of the data link.
- For best performance, it is recommended to minimize the length of D+/D- board traces from the MCU to ISOUSB211, and from ISOUSB211 to the connector. Vias and stubs on D+/D- lines must be avoided. This is especially important for High Speed Operation.
- Placing a solid ground plane just below the high-speed signal layer establishes controlled impedance for transmission line interconnects and provides an excellent low-inductance path for the return current flow. D+ and D- traces must be designed for 90-Ω differential impedance and as close to 45-Ω single ended impedance as possible.
- Placing the power plane next to the ground plane creates additional high-frequency bypass capacitance of approximately 100 pF/in².
- Decoupling capacitors must be placed on the top layer, and the routing between the capacitors and the corresponding to supply and ground pins must be completed in the top layer itself. There should not be any vias in the routing path between the decoupling capacitors and the corresponding supply and ground pins.
- ESD structures must be placed on the top layer, close to the connector, and right on the D+/D- traces without vias. Ground routing for the ESD structures must be made in the top layer if possible, else must have a strong connection to the ground plane with multiple vias.
- Routing the slower speed control signals on the bottom layer allows for greater flexibility as these signal links usually have margin to tolerate discontinuities such as vias.
- Connect a small plane (for example, 2 mm x 2 mm) to the GND pins on the top layer to improve thermal performance. Connect this to the ground player in the second layer with multiple vias. See [Layout Example](#) for details.

11.1.1 Layout Example

The layout example in this section shows the recommended placement for de-coupling capacitors and ESD protection diodes. A continuous ground plane is recommended below the D+/D- signal traces. Small footprint capacitors (0402/0201) are recommended so that these may be placed very close to the supply pins and corresponding ground pins and connected using the top layer. There should not be any vias in the routing path between the decoupling capacitors and the corresponding supply and ground pins. The capacitors on V_{1P8VX} supplies are higher in priority when considering placement close to the IC. The ESD protection diodes should be placed close to the connector with a strong connection to the ground plane. Pins 4 and 11 for V_{1P8V1} and pins 18 and 25 for V_{1P8V2} are connected together, but this connection is after the de-coupling capacitors. If more than 2 layers are available in the PCB, this connection should be made in an inner or bottom layer (ex. Layer 3 or 4) so as to not interrupt the ground plane under the D+/D- traces. The example shown is for an isolated host or hub, but similar considerations apply for isolated peripherals also. The 120-μF capacitor on VBUS only applies to host or hub and should not be used for peripherals. A ferrite bead, with dc resistance less than 100 mΩ, may be optionally placed on the VBUS route, after the 100-nF (and 120-μF) capacitors to prevent transients such as ESD from affecting the rest of the circuits.

For best performance, it is recommended to minimize the length of D+/D- board traces from the MCU to ISOUSB211, and from ISOUSB211 to the connector. Vias and stubs on D+/D- lines must be avoided. This is especially important for High Speed Operation.

Connect a small plane (for example, 2 mm x 2 mm) to the GND pins on the top layer to improve thermal performance. Connect this to the ground player in the second layer with multiple vias.

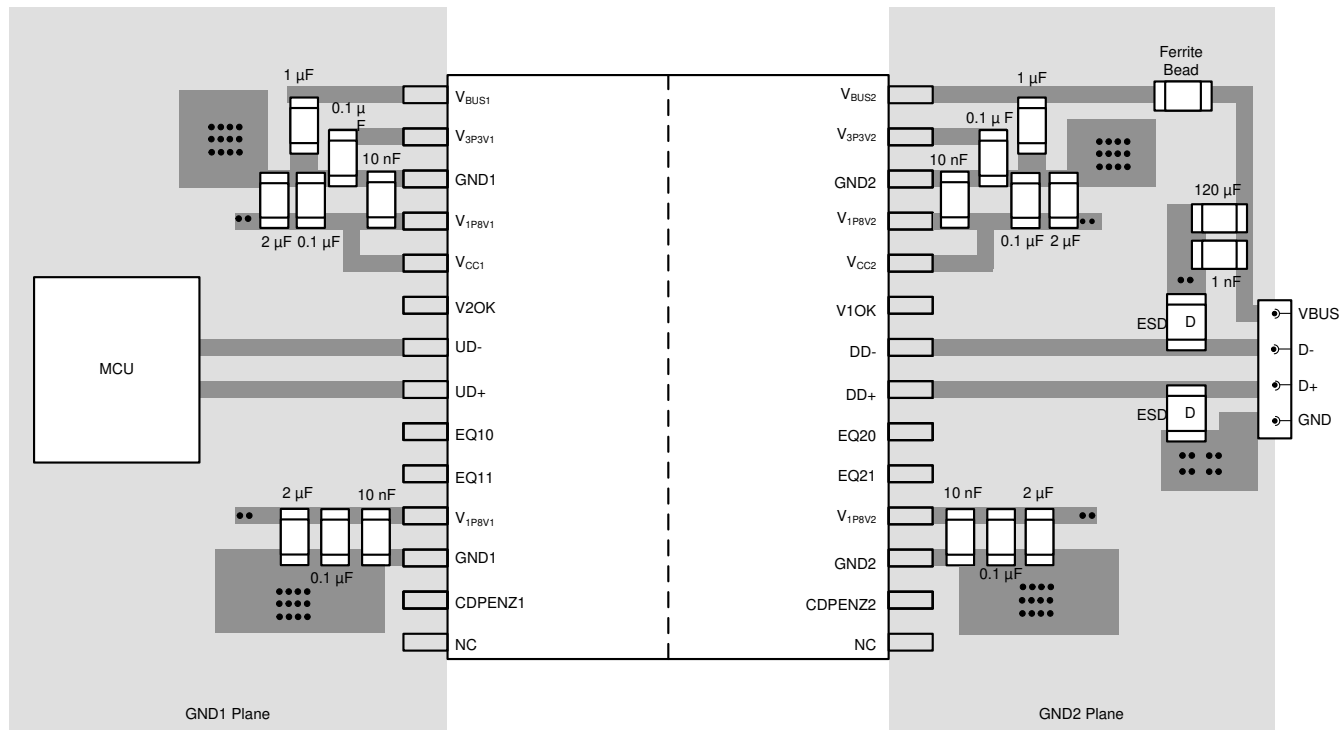

Figure 11-1. Layout Example for ISOUSB211

11.1.2 PCB Material

For digital circuit boards operating at less than 500 Mbps, (or rise and fall times greater than 1 ns), and trace lengths of up to 10 inches, use standard FR-4 UL94V-0 printed circuit board. This PCB is preferred over lower-cost alternatives because of lower dielectric losses at high frequencies, less moisture absorption, greater strength and stiffness, and the self-extinguishing flammability-characteristics.

12 Device and Documentation Support

12.1 Documentation Support

12.1.1 Related Documentation

For related documentation see the following:

- Texas Instruments, [Digital Isolator Design Guide](#)
- Texas Instruments, [Isolation Glossary](#)

12.2 Receiving Notification of Documentation Updates

To receive notification of documentation updates, navigate to the device product folder on ti.com. In the upper right corner, click on *Alert me* to register and receive a weekly digest of any product information that has changed. For change details, review the revision history included in any revised document.

12.3 Support Resources

TI E2E™ support forums are an engineer's go-to source for fast, verified answers and design help — straight from the experts. Search existing answers or ask your own question to get the quick design help you need.

Linked content is provided "AS IS" by the respective contributors. They do not constitute TI specifications and do not necessarily reflect TI's views; see TI's [Terms of Use](#).

12.4 Trademarks

TI E2E™ is a trademark of Texas Instruments.
All trademarks are the property of their respective owners.

12.5 Electrostatic Discharge Caution



This integrated circuit can be damaged by ESD. Texas Instruments recommends that all integrated circuits be handled with appropriate precautions. Failure to observe proper handling and installation procedures can cause damage.

ESD damage can range from subtle performance degradation to complete device failure. Precision integrated circuits may be more susceptible to damage because very small parametric changes could cause the device not to meet its published specifications.

12.6 Glossary

[TI Glossary](#) This glossary lists and explains terms, acronyms, and definitions.

13 Mechanical, Packaging, and Orderable Information

The following pages include mechanical packaging and orderable information. This information is the most current data available for the designated devices. This data is subject to change without notice and revision of this document. For browser-based versions of this data sheet, refer to the left-hand navigation.

PACKAGE OUTLINE

DP0028A-C01

SSOP - 2.65 mm max height

SMALL OUTLINE PACKAGE

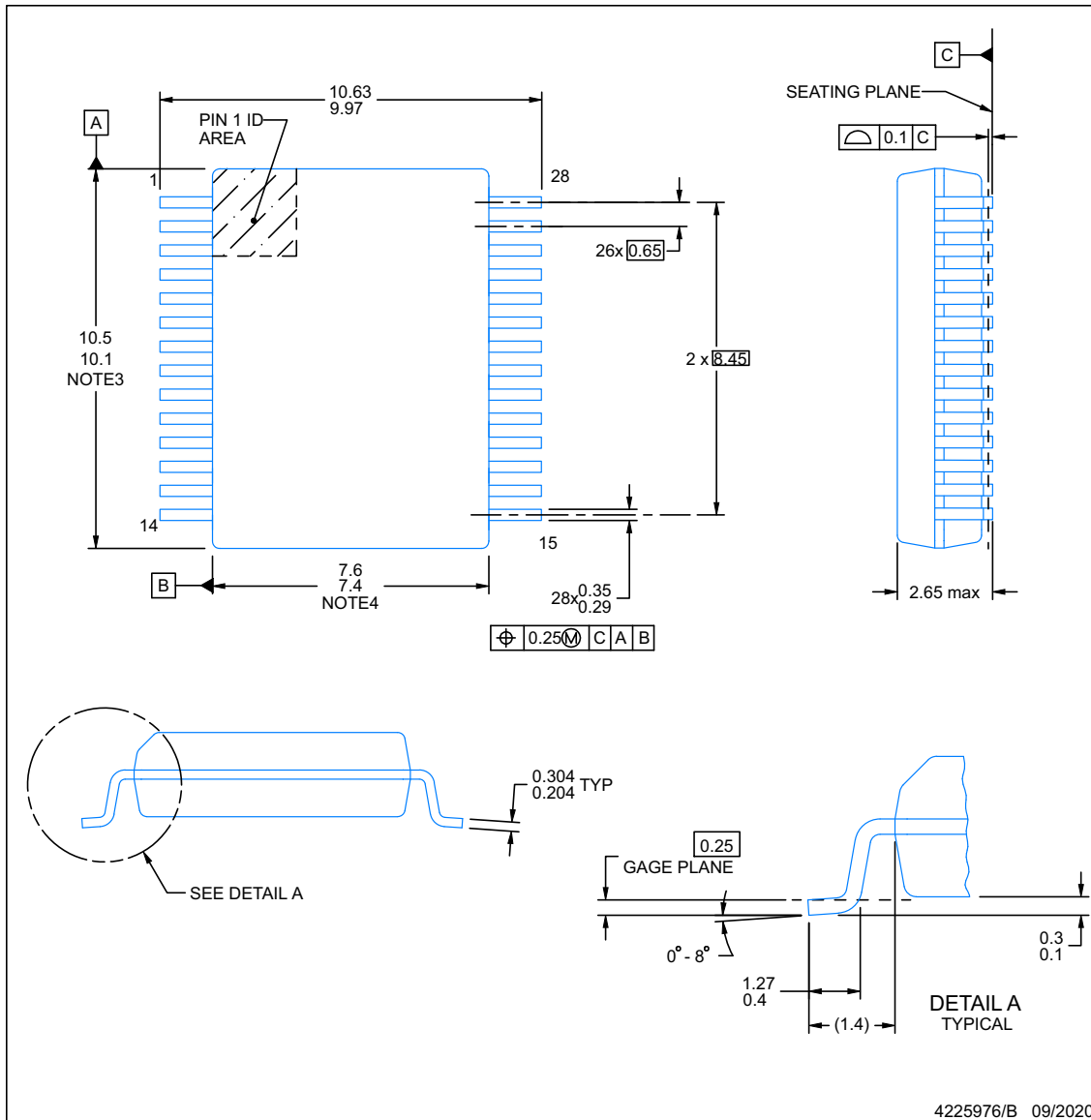

NOTES:

1. All linear dimensions are in millimeters. Dimensions in parenthesis are for reference only. Dimensioning and tolerancing per ASME Y14.5M.
2. This drawing is subject to change without notice.
3. This dimension does not include mold flash, protrusions, or gate burrs. Mold flash, protrusions, or gate burrs shall not exceed 0.15 mm, per side.
4. This dimension does not include interlead flash. Interlead flash shall not exceed 0.25 mm, per side.
5. Reference JEDEC registration MS-013.

EXAMPLE BOARD LAYOUT

DP0028A-C01

SSOP - 2.65 mm max height

SSOP

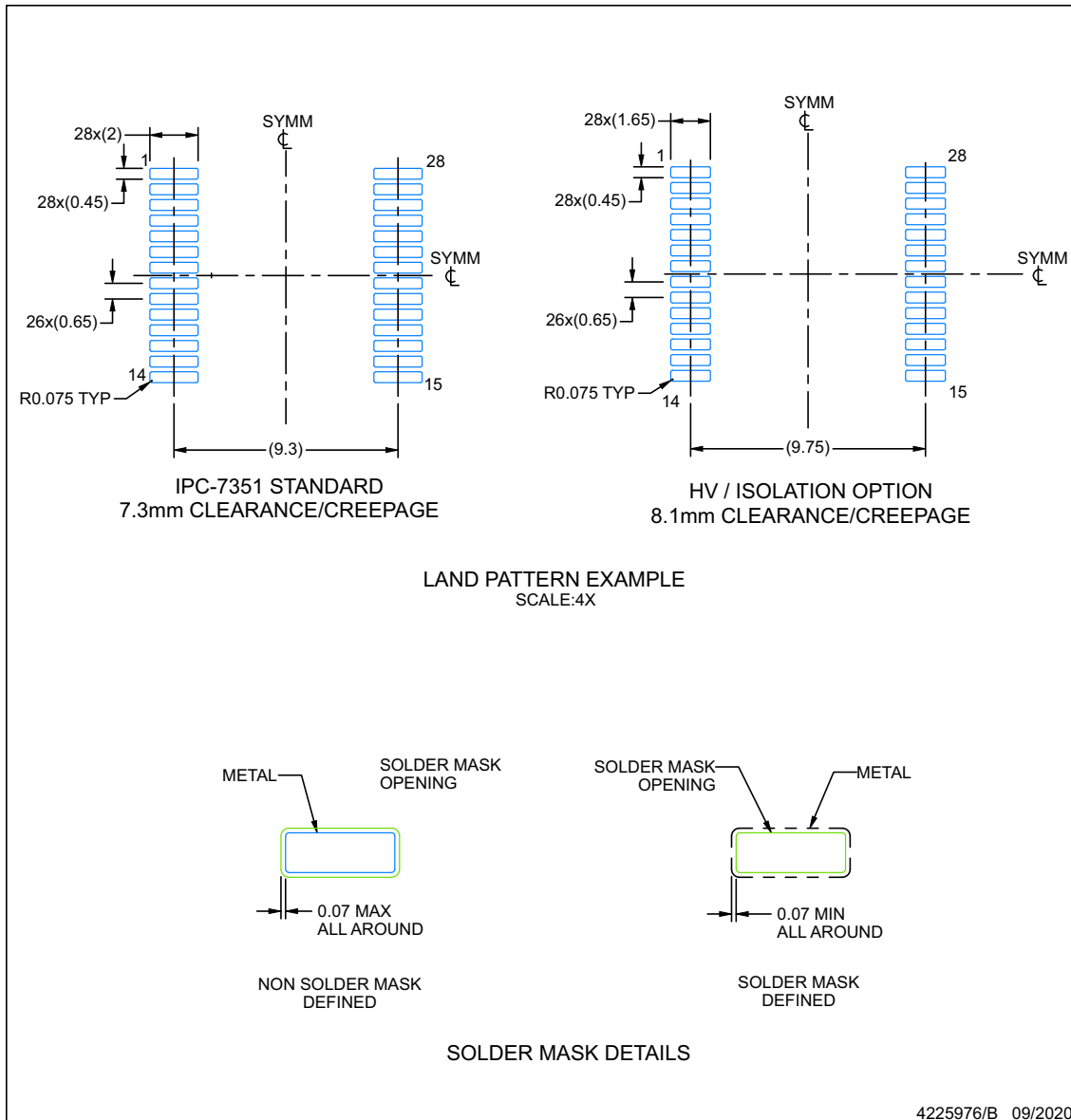

NOTES: (continued)

- 6. Publication IPC-7351 may have alternate designs.
- 7. Solder mask tolerances between and around signal pads can vary based on board fabrication site.

EXAMPLE STENCIL DESIGN

DP0028A-C01

SSOP - 2.65 mm max height

SSOP

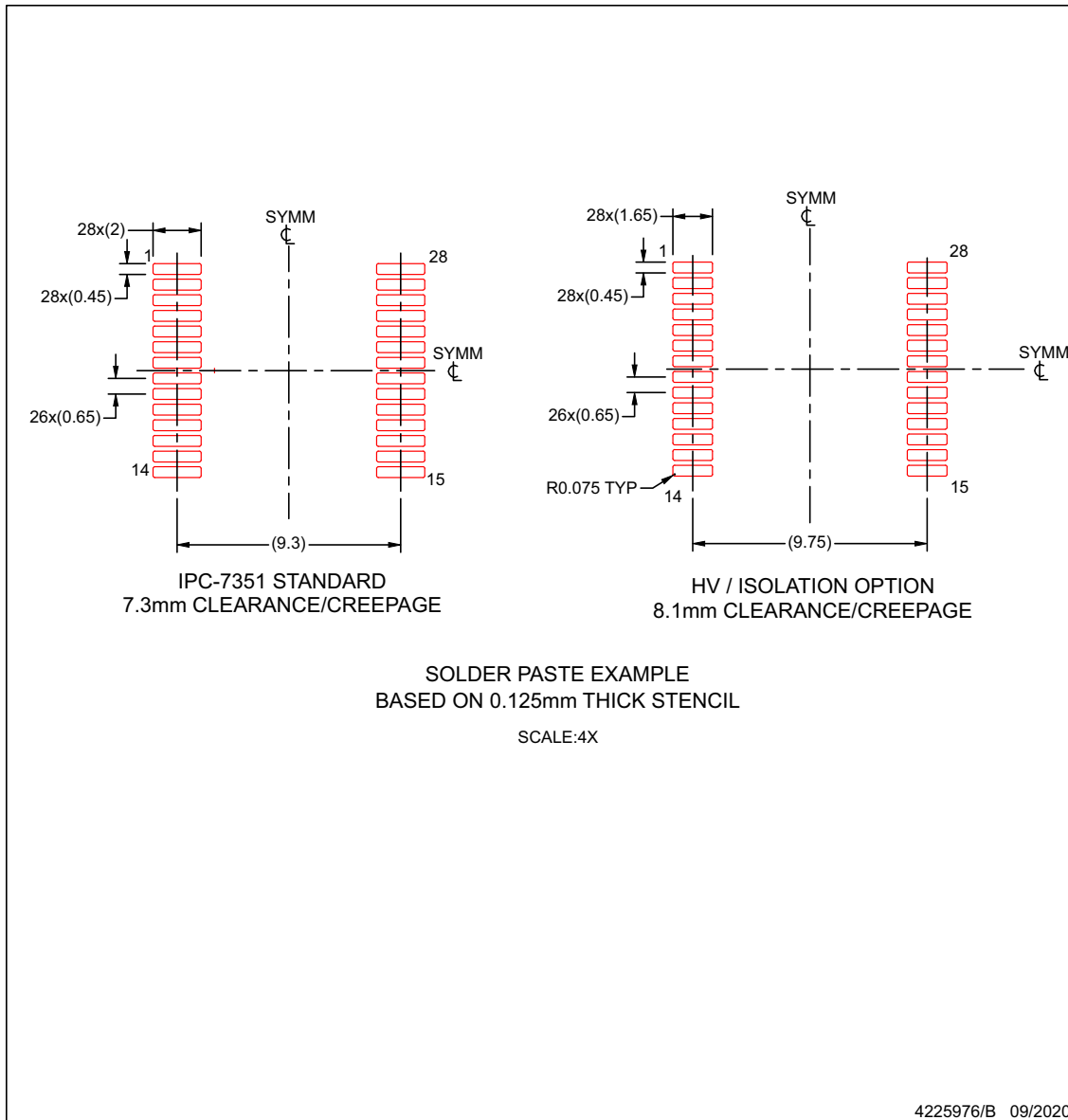

NOTES: (continued)

- 8. Laser cutting apertures with trapezoidal walls and rounded corners may offer better paste release. IPC-7525 may have alternate design recommendations.
- 9. Board assembly site may have different recommendations for stencil design.

13.1 Tape and Reel Information

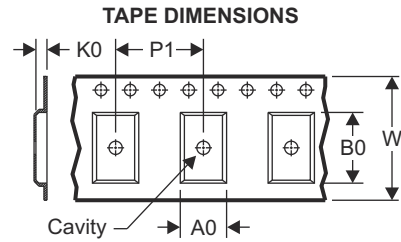
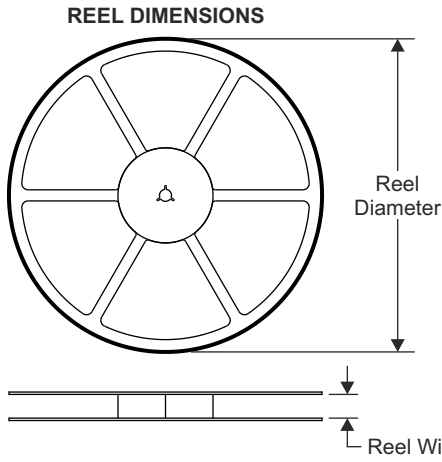

A0	Dimension designed to accommodate the component width
B0	Dimension designed to accommodate the component length
K0	Dimension designed to accommodate the component thickness
W	Overall width of the carrier tape
P1	Pitch between successive cavity centers

QUADRANT ASSIGNMENTS FOR PIN 1 ORIENTATION IN TAPE

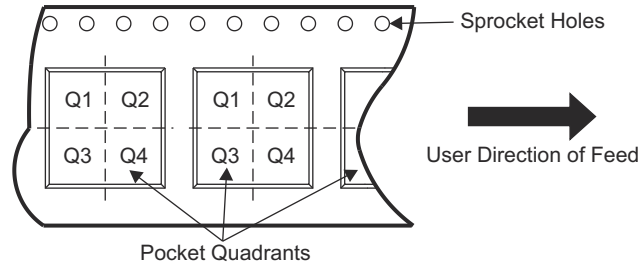

Device	Package Type	Package Drawing	Pins	SPQ	Reel Diameter (mm)	Reel Width W1 (mm)	A0 (mm)	B0 (mm)	K0 (mm)	P1 (mm)	W (mm)	Pin1 Quadrant
ISOUSB211DPR	SSOP	DP	28	2000	330.0	16.4	10.75	10.7	2.7	12.0	16.0	Q1

TAPE AND REEL BOX DIMENSIONS

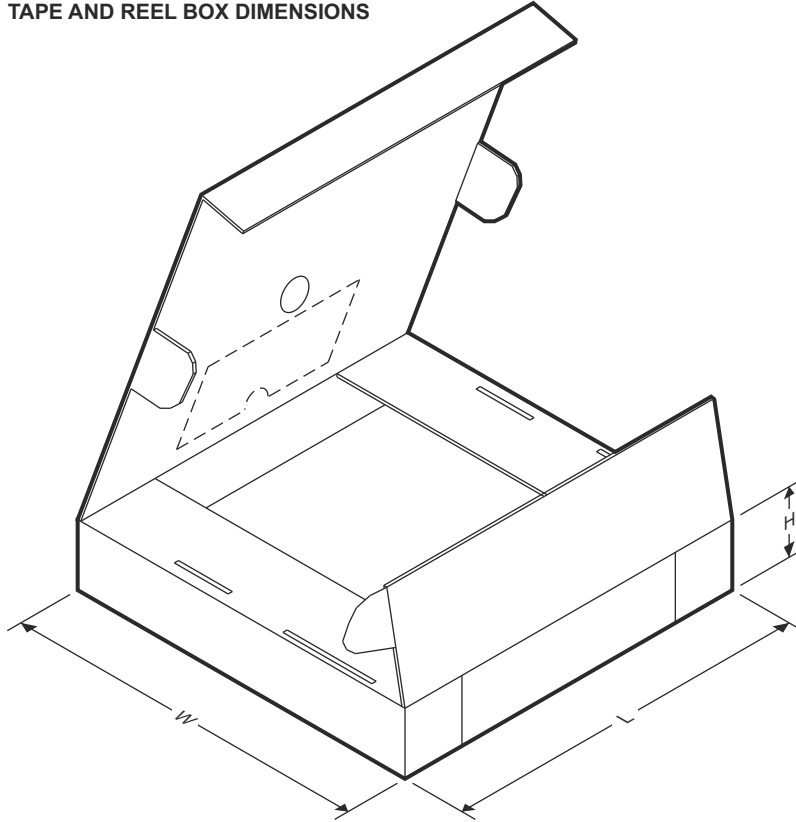

Device	Package Type	Package Drawing	Pins	SPQ	Length (mm)	Width (mm)	Height (mm)
ISOUSB211DPR	SSOP	DP	28	2000	350.0	350.0	43.0

PACKAGING INFORMATION

Orderable Device	Status (1)	Package Type	Package Drawing	Pins	Package Qty	Eco Plan (2)	Lead finish/ Ball material (6)	MSL Peak Temp (3)	Op Temp (°C)	Device Marking (4/5)	Samples
ISOUSB211DPR	ACTIVE	SSOP	DP	28	2000	RoHS & Green	NIPDAU	Level-3-260C-168 HR	-40 to 125	ISOUSB211	Samples

(1) The marketing status values are defined as follows:

ACTIVE: Product device recommended for new designs.

LIFEBUY: TI has announced that the device will be discontinued, and a lifetime-buy period is in effect.

NRND: Not recommended for new designs. Device is in production to support existing customers, but TI does not recommend using this part in a new design.

PREVIEW: Device has been announced but is not in production. Samples may or may not be available.

OBSELETE: TI has discontinued the production of the device.

(2) **RoHS:** TI defines "RoHS" to mean semiconductor products that are compliant with the current EU RoHS requirements for all 10 RoHS substances, including the requirement that RoHS substance do not exceed 0.1% by weight in homogeneous materials. Where designed to be soldered at high temperatures, "RoHS" products are suitable for use in specified lead-free processes. TI may reference these types of products as "Pb-Free".

RoHS Exempt: TI defines "RoHS Exempt" to mean products that contain lead but are compliant with EU RoHS pursuant to a specific EU RoHS exemption.

Green: TI defines "Green" to mean the content of Chlorine (Cl) and Bromine (Br) based flame retardants meet JS709B low halogen requirements of <=1000ppm threshold. Antimony trioxide based flame retardants must also meet the <=1000ppm threshold requirement.

(3) MSL, Peak Temp. - The Moisture Sensitivity Level rating according to the JEDEC industry standard classifications, and peak solder temperature.

(4) There may be additional marking, which relates to the logo, the lot trace code information, or the environmental category on the device.

(5) Multiple Device Markings will be inside parentheses. Only one Device Marking contained in parentheses and separated by a "~" will appear on a device. If a line is indented then it is a continuation of the previous line and the two combined represent the entire Device Marking for that device.

(6) Lead finish/Ball material - Orderable Devices may have multiple material finish options. Finish options are separated by a vertical ruled line. Lead finish/Ball material values may wrap to two lines if the finish value exceeds the maximum column width.

Important Information and Disclaimer:The information provided on this page represents TI's knowledge and belief as of the date that it is provided. TI bases its knowledge and belief on information provided by third parties, and makes no representation or warranty as to the accuracy of such information. Efforts are underway to better integrate information from third parties. TI has taken and continues to take reasonable steps to provide representative and accurate information but may not have conducted destructive testing or chemical analysis on incoming materials and chemicals. TI and TI suppliers consider certain information to be proprietary, and thus CAS numbers and other limited information may not be available for release.

In no event shall TI's liability arising out of such information exceed the total purchase price of the TI part(s) at issue in this document sold by TI to Customer on an annual basis.

IMPORTANT NOTICE AND DISCLAIMER

TI PROVIDES TECHNICAL AND RELIABILITY DATA (INCLUDING DATA SHEETS), DESIGN RESOURCES (INCLUDING REFERENCE DESIGNS), APPLICATION OR OTHER DESIGN ADVICE, WEB TOOLS, SAFETY INFORMATION, AND OTHER RESOURCES "AS IS" AND WITH ALL FAULTS, AND DISCLAIMS ALL WARRANTIES, EXPRESS AND IMPLIED, INCLUDING WITHOUT LIMITATION ANY IMPLIED WARRANTIES OF MERCHANTABILITY, FITNESS FOR A PARTICULAR PURPOSE OR NON-INFRINGEMENT OF THIRD PARTY INTELLECTUAL PROPERTY RIGHTS.

These resources are intended for skilled developers designing with TI products. You are solely responsible for (1) selecting the appropriate TI products for your application, (2) designing, validating and testing your application, and (3) ensuring your application meets applicable standards, and any other safety, security, regulatory or other requirements.

These resources are subject to change without notice. TI grants you permission to use these resources only for development of an application that uses the TI products described in the resource. Other reproduction and display of these resources is prohibited. No license is granted to any other TI intellectual property right or to any third party intellectual property right. TI disclaims responsibility for, and you will fully indemnify TI and its representatives against, any claims, damages, costs, losses, and liabilities arising out of your use of these resources.

TI's products are provided subject to [TI's Terms of Sale](#) or other applicable terms available either on [ti.com](https://www.ti.com) or provided in conjunction with such TI products. TI's provision of these resources does not expand or otherwise alter TI's applicable warranties or warranty disclaimers for TI products.

TI objects to and rejects any additional or different terms you may have proposed.

Mailing Address: Texas Instruments, Post Office Box 655303, Dallas, Texas 75265
Copyright © 2023, Texas Instruments Incorporated

Looking for pricing, stock, or lifecycle information?

Click below to explore more details on WIN SOURCE:

 [View ISOUSB211DPR](#) on WIN SOURCE

 [Texas Instruments](#) Information

Optimize Your Supply Chain with WIN SOURCE Solutions

-  Global Sourcing Solution
-  Obsolete Management
-  Cost Control Management
-  Shortage Management
-  Alternative Solution
-  Excess Inventory Management