



# THE DATASHEET OF CA50C24C3ILT



# Model CA50C

## AUTOMOTIVE GRADE HCMOS CLOCK

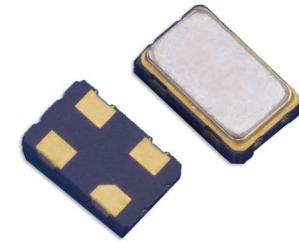

Part Dimensions:  
5.0 × 3.2 × 1.3mm • 60.7734mg

### Features

- AEC-Q200 Compliant
- Ceramic Surface Mount Package
- Operating Temperature Ranges to -55°C to +105°C
- Fundamental and 3<sup>rd</sup> Overtone Crystal Designs
- Frequency Range 1.25 – 156.25MHz \*
- +1.8V, +2.5V, +3.3V Operation; +5.0V Limited Availability
- Output Enable Standard
- Tape and Reel Packaging, EIA-481

### Standard Frequencies

\* See Page 6 for common frequencies.  
Check with factory for availability of frequencies not listed and for +5.0V operation.

### Applications

- Automotive Electronics
- IoT and IIoT
- Medical Electronics
- Mobile Multimedia/Infotainment
- Wireless Communication
- Commercial Military & Aerospace

### Description

CTS Model CA50C is a low cost, small size, Clock Oscillator [XO] developed for use in automotive electronics operating over extended temperature ranges. CA50C has an HCMOS/TTL compatible output, offers excellent stability and low jitter/phase noise performance.

### Ordering Information

Model		Output Type	Frequency Code [MHz]	Frequency Stability	Temperature Range	Supply Voltage	Packaging
CA	50	C	XXX or XXXX	3	G	L	T
Code Package Size		Code Frequency		Code Temp. Range		Code Packing	
50	5.0x3.2mm	Product Frequency Code <sup>1</sup>		I -40°C to +85°C		T 1k pcs./reel	
Code Output		Code Stability		Code Stability		Code Voltage	
C HCMOS		5 ±25ppm		3 ±50ppm		M +1.8Vdc	
		4 ±30ppm		2 ±100ppm		N +2.5Vdc	
						L +3.3Vdc	
						S +5.0Vdc	

#### Notes:

- 1] Refer to document O16-1454-0, Frequency Code Tables. 3-digits for frequencies <100MHz, 4-digits for frequencies 100MHz or greater.
- 2] Available with stability codes 4, 3, 2 and 7.
- 3] Available with stability codes 3, 2 and 7.
- 4] Stability codes 2 and 7. Contact factory for availability. Not available with voltage code "S".

**Not all performance combinations and frequencies may be available.  
Contact your local CTS Representative or CTS Customer Service for availability.**

This product is specified for use only in standard commercial applications. Supplier disclaims all express and implied warranties and liability in connection with any use of this product in any non-commercial applications or in any application that may expose the product to conditions that are outside of the tolerances provided in its specification.



## Electrical Specifications

### Operating Conditions

PARAMETER	SYMBOL	CONDITIONS	MIN	TYP	MAX	UNIT
Maximum Supply Voltage	$V_{CC}$	$V_{CC} +1.8V$ to $+3.3V$	-0.5	-	4.0	V
Supply Voltage	$V_{CC}$	$\pm 5\%$	1.710	1.8	1.890	V
			2.375	2.5	2.665	
			3.135	3.3	3.465	
			4.750	5.0	5.250	
Typical @ Nominal $V_{CC}$ , $C_L = 15$ pF, $T_A = +25^\circ C$						
Supply Current	$I_{CC}$	@ +1.8V	-	15	25	mA
		@ +2.5V	-	20	30	
		@ +3.3V	-	35	40	
		@ +5.0V	-	35	55	
Output Load	$C_L$	-	-	-	15	pF
Operating Temperature	$T_A$	-	-40	+25	+125	$^\circ C$
			-40		+105	
			-55		+105	
			-55		+125	
Storage Temperature	$T_{STG}$	-	-55	-	+125	$^\circ C$

### Frequency Stability

PARAMETER	SYMBOL	CONDITIONS	MIN	TYP	MAX	UNIT
Frequency Range	$f_0$	-		1.25 - 156.25		MHz
Frequency Stability [Note 1]	$\Delta f/f_0$	-		25, 30, 50, 100 or 150		$\pm$ ppm
Aging	$\Delta f/f_{25}$	First Year @ $+25^\circ C$ , nominal $V_{CC}$	-5	-	5	ppm

1.] Inclusive of initial tolerance at time of shipment, changes in supply voltage, load, temperature and 1st year aging.

### Output Parameters

PARAMETER	SYMBOL	CONDITIONS	MIN	TYP	MAX	UNIT
Output Type	-	-		HCMOS		-
Output Voltage Levels	$V_{OH}$	Logic '1' Level, CMOS Load	$0.9V_{CC}$	-	-	V
	$V_{OL}$	Logic '0' Level, CMOS Load	-	-	$0.1V_{CC}$	
Output Current Levels	$I_{OH}$	$V_{OH} = 90\%V_{CC}$ [1.8V, 2.5V, 3.3V, 5.0V]	-	-	-4, -4, -8, -16	mA
	$I_{OL}$	$V_{OL} = 10\%V_{CC}$ [1.8V, 2.5V, 3.3V, 5.0V]	-	-	+4, +4, +8, +16	
Output Duty Cycle	SYM	@ 50% Level	45	-	55	%
Rise and Fall Time [Note 2]	$T_R, T_F$	@ +1.8V	-	4	5	ns
		@ +2.5V	-	4	5	
		@ +3.3V	-	7	10	
		@ +5.0V	-	7	10	
Start Up Time	$T_S$	Application of $V_{CC}$	-	2	5	ms

2.] Parameters are worst case and account for comprehensive range of product specification. Performance may vary by application and must be validated by end user.

## Electrical Specifications

### Output Parameters

PARAMETER	SYMBOL	CONDITIONS	MIN	TYP	MAX	UNIT
Enable Function		Standby				
Enable Input Voltage	$V_{IH}$	Pin 1 Logic '1', Output Enabled	0.7V <sub>CC</sub>	-	-	V
Disable Input Voltage	$V_{IL}$	Pin 1 Logic '0', Output Standby	-	-	0.3V <sub>CC</sub>	V
Enable Current	$I_{STB}$	Pin 1 Logic '0', Output Standby	-	-	10	μA
Enable Time	$T_{PLZ}$	Pin 1 Logic '1'	-	-	5	ms
Phase Jitter, RMS	$t_{jrms}$	Bandwidth 12 kHz - 20 MHz	-	0.5	<1	ps

### Enable Truth Table

Pin 1	Pin 3
Logic '1'	Output Enabled
Open	Output Enabled
Logic '0'	Output Disabled, High Impedance

### Test Circuit

HCMOS

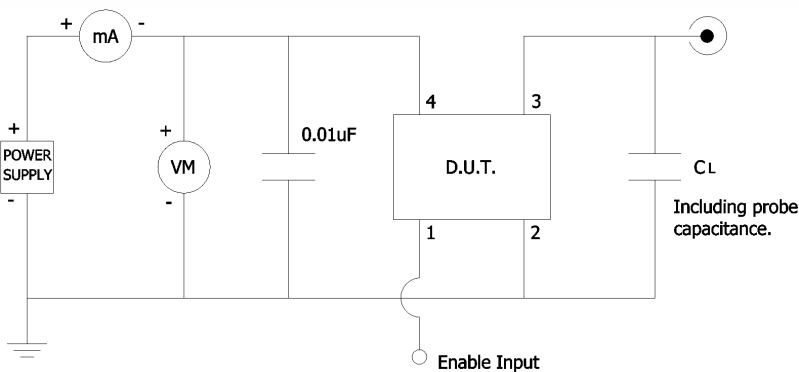

### Output Waveform

HCMOS

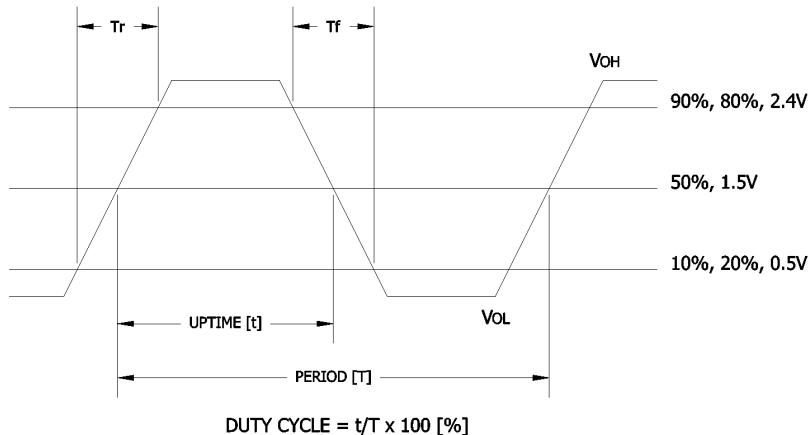

## Mechanical Specifications

### Package Drawing

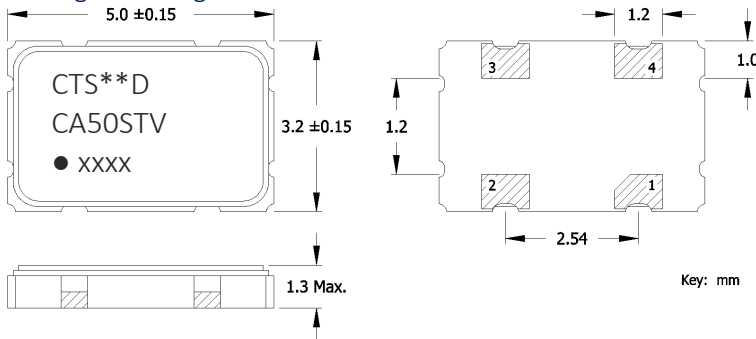

### Marking Information

- \*\* – Manufacturing Site Code.
- D – Date Code. See Table I for codes.
- CA50 – CTS model.
- ST – Frequency stability/temperature code. [Refer to Ordering Information]
- V – Voltage code; M = 1.8V, N = 2.5V, L = 3.3V, S = 5.0V.
- – Pin 1 identifier.
- xxxx – Frequency Code.  
 3-digits for frequencies <100MHz  
 4-digits for frequencies 100MHz or greater  
 [See document 016-1454-0, Frequency Code Tables.]

### Recommended Pad Layout

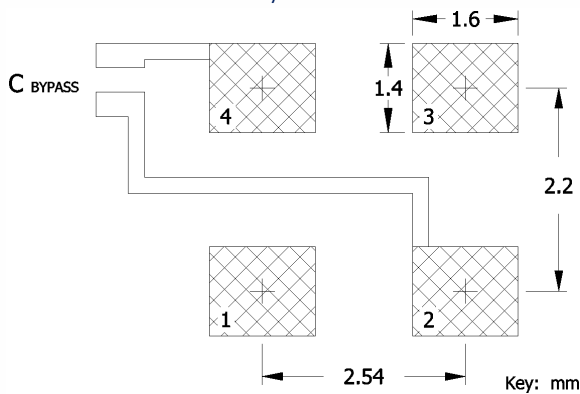

- Termination pads (e4). Barrier-plating is nickel [Ni] with gold [Au] flash plate.
- Reflow conditions per JEDEC J-STD-020; +260°C maximum, 20 seconds.
- MSL = 1.

### Pin Assignments

Pin	Symbol	Function
1	EOH	Enable
2	GND	Circuit & Package
3	Output	RF Output
4	V <sub>CC</sub>	Supply Voltage

Table I - Date Code, Beginning year 2021

					MONTH											
					JAN	FEB	MAR	APR	MAY	JUN	JUL	AUG	SEP	OCT	NOV	DEC
YEAR																
2021	2025	2029	2033	2037	A	B	C	D	E	F	G	H	J	K	L	M
2022	2026	2030	2034	2038	N	P	Q	R	S	T	U	V	W	X	Y	Z
2023	2027	2031	2035	2039	a	b	c	d	e	f	g	h	j	k	l	m
2024	2028	2032	2036	2040	n	p	q	r	s	t	u	v	w	x	y	z

### Packaging - Tape and Reel

#### Tape Drawing

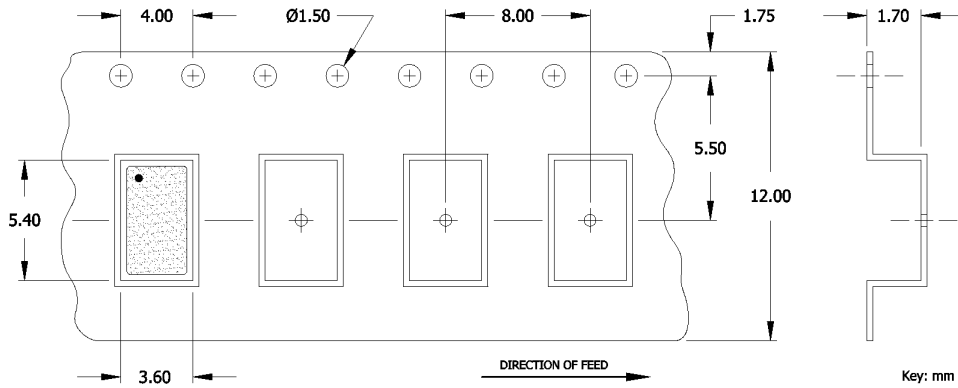

#### Reel Drawing

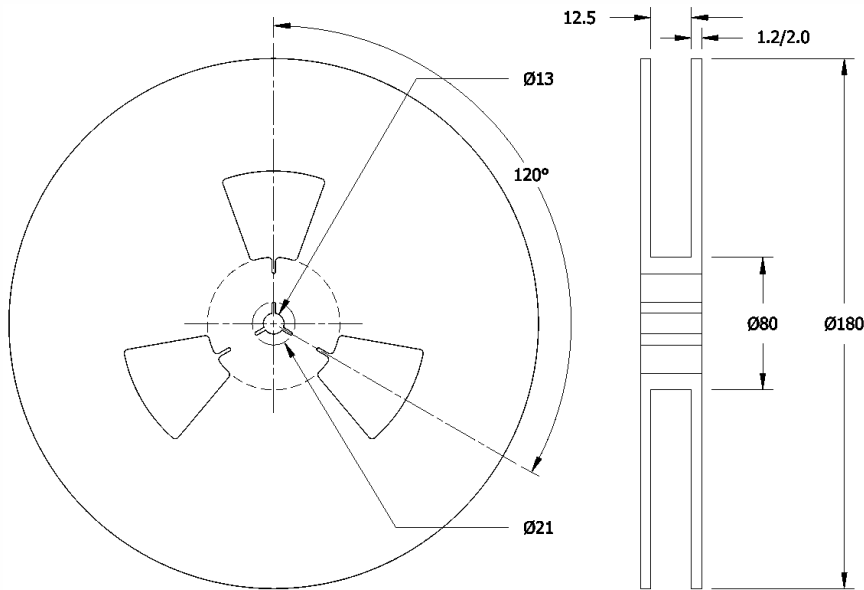

#### Notes

1. Device quantity is 1k pieces maximum per 180mm reel.
2. Complete CTS part number, frequency value and date code information must appear on reel and carton labels.



## Addendum

### Common Frequencies Available – MHz

FREQUENCY	FREQUENCY CODE	FREQUENCY	FREQUENCY CODE	FREQUENCY	FREQUENCY CODE	FREQUENCY	FREQUENCY CODE
4.000000	040	24.000000	240	40.000000	400		
8.000000	080	24.576000	24C	48.000000	480		
10.000000	100	25.000000	250	50.000000	500		
12.000000	120	26.000000	260	100.000000	1000		
12.288000	122	27.000000	270	125.000000	1250		
14.318180	143	30.000000	300	156.250000	1562		
14.745600	147	32.000000	320				
16.000000	160	33.333000	33E				
20.000000	200	37.400000	374				
22.118400	221	38.400000	384				

## Looking for pricing, stock, or lifecycle information?

Click below to explore more details on WIN SOURCE:

- ⊖ [View CA50C24C3ILT on WIN SOURCE](#)
- ⊖ [CTS-Frequency Controls Information](#)

## Optimize Your Supply Chain with WIN SOURCE Solutions

- ✓ Global Sourcing Solution
- ✓ Obsolete Management
- ✓ Cost Control Management
- ✓ Shortage Management
- ✓ Alternative Solution
- ✓ Excess Inventory Management