



**THE DATASHEET OF
ICS85222AM-02LFT**



GENERAL DESCRIPTION

The 85222-02 is a 1-to-2 LVCMOS / LVTTL-to-Differential HSTL translator. The 85222-02 has one single ended clock input. The single-ended clock input accepts LVCMOS or LVTTL input levels and translates them to HSTL levels. The small outline 8-pin SOIC package makes this device ideal for applications where space, high performance and low power are important.

FEATURES

- Two differential HSTL outputs
- One LVCMOS/LVTTL clock input
- CLK input can accept the following input levels: LVCMOS or LVTTL
- Maximum output frequency: 350MHz
- Part-to-part skew: 250ps (maximum)
- Propagation delay: 1.25ns (maximum)
- V_{OH} : 1.4V (maximum)
- Output crossover voltage: 0.68V - 0.9V
- Full 3.3V operating supply voltage
- 0°C to 70°C ambient operating temperature
- Industrial temperature information available upon request
- Available in lead-free RoHS compliant package

BLOCK DIAGRAM

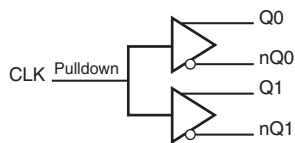

PIN ASSIGNMENT

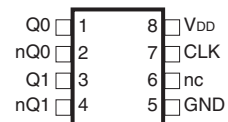

85222-02

8-Lead SOIC

3.90mm x 4.92mm x 1.37mm body package

M Package

Top View

TABLE 1. PIN DESCRIPTIONS

Number	Name	Type		Description
1, 2	Q0, nQ0	Output		Differential output pair. HSTL interface levels.
3, 4	Q1, nQ1	Output		Differential output pair. HSTL interface levels.
5	GND	Power		Power supply ground.
6	nc	Unused		No connect.
7	CLK	Input	Pulldown	LVC MOS / LV TTL clock input.
8	V _{DD}	Power		Positive supply pin.

NOTE: *Pulldown* refers to internal input resistors. See Table 2, Pin Characteristics, for typical values.

NOTE: Unused output pairs must be terminated.

TABLE 2. PIN CHARACTERISTICS

Symbol	Parameter	Test Conditions	Minimum	Typical	Maximum	Units
C _{IN}	Input Capacitance			4		pF
R _{PULLDOWN}	Input Pulldown Resistor			51		kΩ

ABSOLUTE MAXIMUM RATINGS

Supply Voltage, V_{DD}	4.6V
Inputs, V_I	-0.5V to $V_{DD} + 0.5V$
Outputs, I_O	
Continuous Current	50mA
Surge Current	100mA
Package Thermal Impedance, θ_{JA}	112.7°C/W (0 lfpm)
Storage Temperature, T_{STG}	-65°C to 150°C

NOTE: Stresses beyond those listed under Absolute Maximum Ratings may cause permanent damage to the device. These ratings are stress specifications only. Functional operation of product at these conditions or any conditions beyond those listed in the *DC Characteristics* or *AC Characteristics* is not implied. Exposure to absolute maximum rating conditions for extended periods may affect product reliability.

TABLE 3A. POWER SUPPLY DC CHARACTERISTICS, $V_{DD} = 3.3V \pm 5\%$, $T_A = 0^\circ C$ TO $70^\circ C$

Symbol	Parameter	Test Conditions	Minimum	Typical	Maximum	Units
V_{DD}	Positive Supply Voltage		3.135	3.3	3.465	V
I_{DD}	Power Supply Current				50	mA

TABLE 3B. LVCMOS / LVTTTL DC CHARACTERISTICS, $V_{DD} = 3.3V \pm 5\%$, $T_A = 0^\circ C$ TO $70^\circ C$

Symbol	Parameter	Test Conditions	Minimum	Typical	Maximum	Units
V_{IH}	Input High Voltage		2		$V_{DD} + 0.3$	V
V_{IL}	Input Low Voltage		-0.3		0.8	V
I_{IH}	Input High Current	CLK $V_{DD} = V_{IN} = 3.465V$			150	μA
I_{IL}	Input Low Current	CLK $V_{DD} = 3.465, V_{IN} = 0V$	-5			μA

TABLE 3C. HSTL DC CHARACTERISTICS, $V_{DD} = 3.3V \pm 5\%$, $T_A = 0^\circ C$ TO $70^\circ C$

Symbol	Parameter	Test Conditions	Minimum	Typical	Maximum	Units
V_{OH}	Output High Voltage; NOTE 1		1.0		1.4	V
V_{OL}	Output Low Voltage; NOTE 1		0		0.4	V
V_{OX}	Output Crossover Voltage		0.68		0.9	V
V_{SWING}	Peak-to-Peak Output Voltage Swing		0.6	1.0	1.4	V

NOTE 1: All outputs must be terminated with 50 Ω to ground.

TABLE 4. AC CHARACTERISTICS, $V_{DD} = 3.3V \pm 5\%$, $T_A = 0^\circ C$ TO $70^\circ C$

Symbol	Parameter	Test Conditions	Minimum	Typical	Maximum	Units
f_{MAX}	Output Frequency				350	MHz
t_{PD}	Propagation Delay; NOTE 1		0.85	1.05	1.25	ns
tsk(o)	Output Skew; NOTE 2, 3				25	ps
tsk(pp)	Part-to-Part Skew; NOTE 4				250	ps
t_R / t_F	Output Rise/Fall Time	20% to 80%	250		500	ps
odc	Output Duty Cycle	$f \leq 250MHz$	45		55	%
		$f > 250MHz$	40		60	%

All outputs must be terminated with 50 Ω to ground.

NOTE 1: Measured from $V_{DD}/2$ of the input to the differential output crossing point.

NOTE 2: Defined as skew between outputs at the same supply voltage and with equal load conditions.

NOTE 3: This parameter is defined in accordance with JEDEC Standard 65.

NOTE 4: Defined as skew between outputs on different devices operating at the same supply voltages and with equal load conditions. Using the same type of inputs on each device, the outputs are measured at the differential cross points.

PARAMETER MEASUREMENT INFORMATION

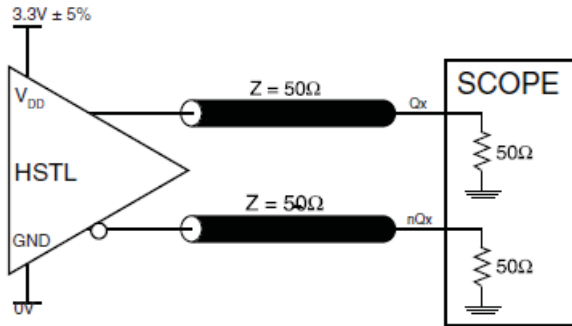

NOTE: All outputs must be terminated with 50Ω to ground.

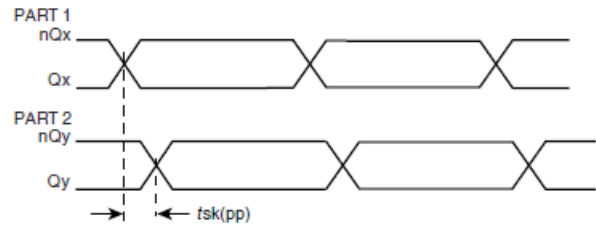

3.3V CORE/3.3V OUTPUT LOAD AC TEST CIRCUIT

PART-TO-PART SKEW

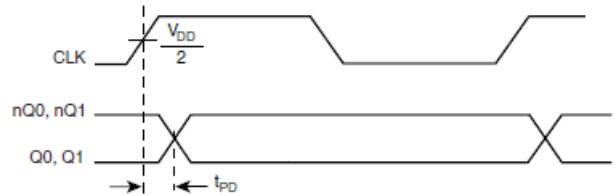
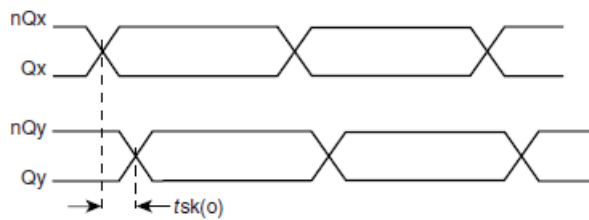

OUTPUT SKEW

PROPAGATION DELAY

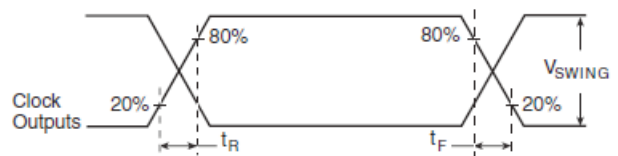
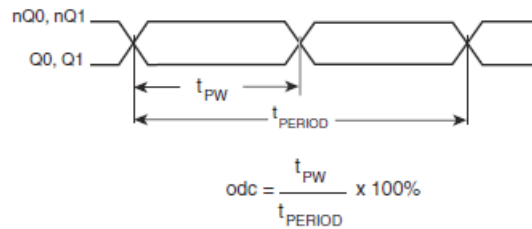

OUTPUT DUTY CYCLE/PULSE WIDTH/PERIOD

OUTPUT RISE/FALL TIME

APPLICATION INFORMATION

RECOMMENDATIONS FOR UNUSED OUTPUT PINS

OUTPUTS:

HSTL OUTPUT

All outputs must be terminated with 50Ω to ground.

SCHEMATIC EXAMPLE

Figure 2 shows a schematic example of 85222-02. In the example, the input is driven by a 7 ohm LVCMOS driver with a series termination. The decoupling capacitor should be physically located

near the power pin. For 85222-02, the unused output need to be terminated.

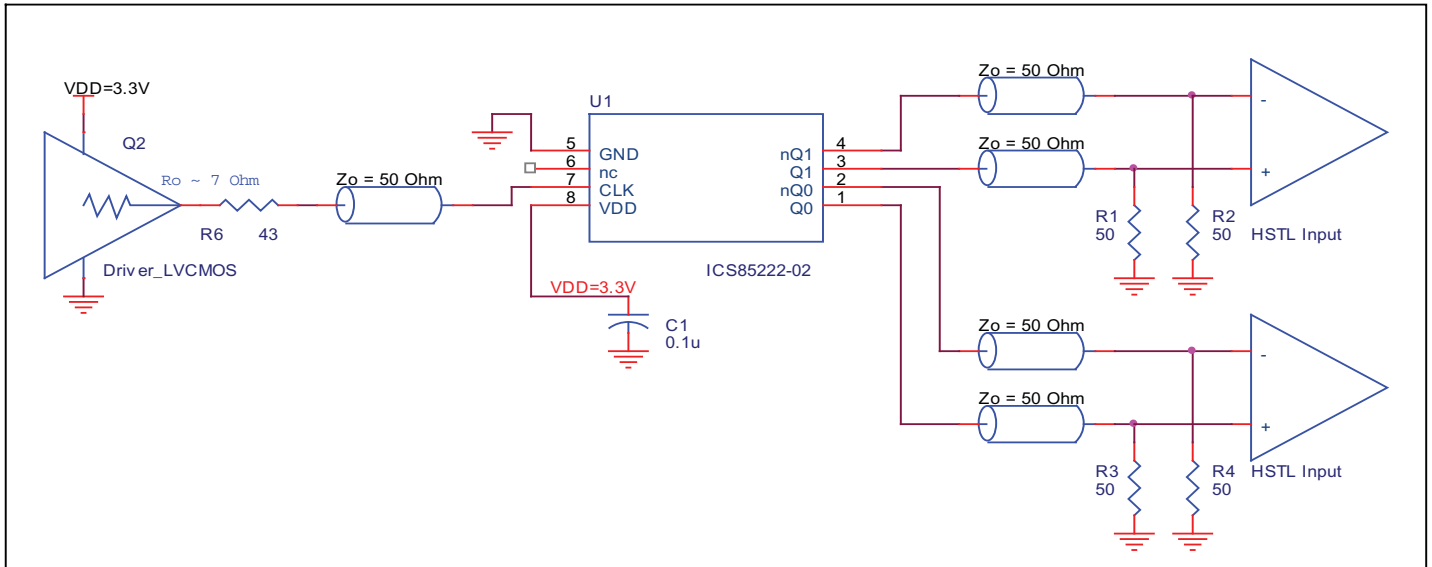

FIGURE 2. 85222-02 HSTL BUFFER SCHEMATIC EXAMPLE

POWER CONSIDERATIONS

This section provides information on power dissipation and junction temperature for the 85222-02. Equations and example calculations are also provided.

1. Power Dissipation.

The total power dissipation for the 85222-02 is the sum of the core power plus the power dissipated in the load(s). The following is the power dissipation for $V_{DD} = 3.3V + 5\% = 3.465V$, which gives worst case results.

NOTE: Please refer to Section 3 for details on calculating power dissipated in the load.

- Power (core)_{MAX} = $V_{DD_MAX} * I_{DD_MAX} = 3.465V * 50mA = 173.25mW$
- Power (outputs)_{MAX} = **73.8mW/Loaded Output pair**
If all outputs are loaded, the total power is $2 * 82.3mW = 164.6mW$

Total Power_{MAX} (3.465V, with all outputs switching) = $173.25mW + 164.6mW = 337.86mW$

2. Junction Temperature.

Junction temperature, T_j, is the temperature at the junction of the bond wire and bond pad and directly affects the reliability of the device. The maximum recommended junction temperature for HiPerClockS™ devices is 125°C.

The equation for T_j is as follows: $T_j = \theta_{JA} * Pd_total + T_A$

T_j = Junction Temperature

θ_{JA} = Junction-to-Ambient Thermal Resistance

Pd_{total} = Total device power dissipation (example calculation is in Section 1 above)

T_A = Ambient Temperature

In order to calculate junction temperature, the appropriate junction-to-ambient thermal resistance θ_{JA} must be used. Assuming a moderate air flow of 200 linear feet per minute and a multi-layer board, the appropriate value is 103.3°C/W per Table 5 below. Therefore, T_j for an ambient temperature of 70°C with all outputs switching is:

$70°C + 0.337W * 103.3°C/W = 104.8°C$. This is below the limit of 125°C.

This calculation is only an example. T_j will obviously vary depending on the number of loaded outputs, supply voltage, air flow, and the type of board (single layer or multi-layer).

TABLE 5. THERMAL RESISTANCE θ_{JA} FOR 8-PIN SOIC, FORCED CONVECTION

	θ_{JA} by Velocity (Linear Feet per Minute)		
	0	200	500
Single-Layer PCB, JEDEC Standard Test Boards	153.3°C/W	128.5°C/W	115.5°C/W
Multi-Layer PCB, JEDEC Standard Test Boards	112.7°C/W	103.3°C/W	97.1°C/W

NOTE: Most modern PCB designs use multi-layered boards. The data in the second row pertains to most designs.

3. Calculations and Equations.

The purpose of this section is to derive the power dissipated into the load.

HSTL output driver circuit and termination are shown in *Figure 1*.

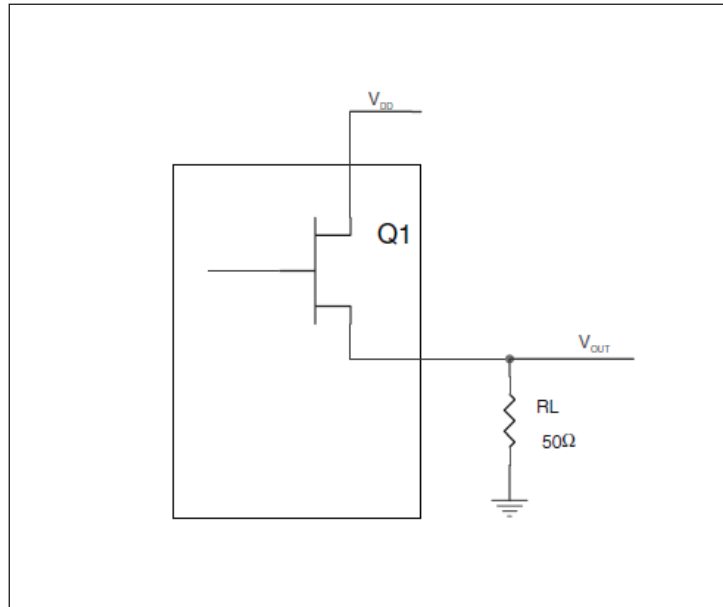

FIGURE 1. HSTL DRIVER CIRCUIT AND TERMINATION

To calculate worst case power dissipation into the load, use the following equations which assume a 50Ω load.

Pd_H is power dissipation when the output drives high.

Pd_L is the power dissipation when the output drives low.

$$Pd_H = (V_{OH_MAX} / R_L) * (V_{DD_MAX} - V_{OH_MAX})$$

$$Pd_L = (V_{OL_MAX} / R_L) * (V_{DD_MAX} - V_{OL_MAX})$$

$$Pd_H = (1.4V / 50\Omega) * (3.465V - 1.4V) = \mathbf{57.8mW}$$

$$Pd_L = (0.4V / 50\Omega) * (3.465V - 0.4V) = \mathbf{24.52mW}$$

$$\text{Total Power Dissipation per output pair} = Pd_H + Pd_L = \mathbf{82.3mW}$$

RELIABILITY INFORMATION

TABLE 6. θ_{JA} vs. AIR FLOW TABLE 8 LEAD SOIC

θ_{JA} by Velocity (Linear Feet per Minute)			
	0	200	500
Single-Layer PCB, JEDEC Standard Test Boards	153.3°C/W	128.5°C/W	115.5°C/W
Multi-Layer PCB, JEDEC Standard Test Boards	112.7°C/W	103.3°C/W	97.1°C/W

NOTE: Most modern PCB designs use multi-layered boards. The data in the second row pertains to most designs.

TRANSISTOR COUNT

The transistor count for 85222-02 is: 411

PACKAGE OUTLINE - M SUFFIX FOR 8 LEAD SOIC

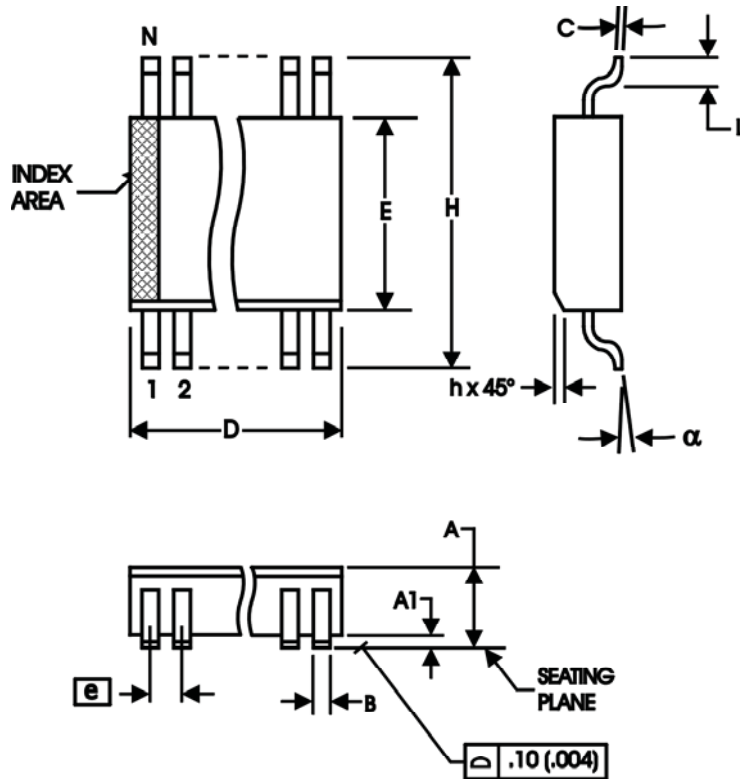

TABLE 7. PACKAGE DIMENSIONS

SYMBOL	Millimeters	
	MINIMUM	MAXIMUM
N	8	
A	1.35	1.75
A1	0.10	0.25
B	0.33	0.51
C	0.19	0.25
D	4.80	5.00
E	3.80	4.00
e	1.27 BASIC	
H	5.80	6.20
h	0.25	0.50
L	0.40	1.27
α	0°	8°

Reference Document: JEDEC Publication 95, MS-012

TABLE 8. ORDERING INFORMATION

Part/Order Number	Marking	Package	Shipping Package	Temperature
ICS85222AM-02LF	5222A02L	8 Lead "Lead-Free" SOIC	tube	0°C to 70°C
ICS85222AM-02LFT	5222A02L	8 Lead "Lead-Free" SOIC	tape & reel	0°C to 70°C

NOTE: Parts that are ordered with an "LF" suffix to the part number are the Pb-Free configuration and are RoHS compliant.

REVISION HISTORY SHEET				
Rev	Table	Page	Description of Change	Date
A		5 6-7	Added <i>Schematic Example</i> . Power Considerations - corrected power dissipation in calculations.	7/24/06
B	T1 T2 T3B	1 2 2 3	Updated Block Diagram with Pulldown for CLK. Pin Description - changed pin 7 as Pulldown instead of Pullup. Changed note to reflect Pulldown. Pin Characteristics - changed Pullup Resistor to Pulldown. LVCMOS DC Characteristics Table - changed I_{IH} from 5 μ A max. to 150 μ A max. and changed I_{IL} from -150 μ A min. to -5 μ A min.	9/12/07
B	T8	10 1	Ordering Information - removed leaded devices. Features Section - removed reference to leaded devices. Updated data sheet format.	6/15/15

IMPORTANT NOTICE AND DISCLAIMER

RENESAS ELECTRONICS CORPORATION AND ITS SUBSIDIARIES (“RENESAS”) PROVIDES TECHNICAL SPECIFICATIONS AND RELIABILITY DATA (INCLUDING DATASHEETS), DESIGN RESOURCES (INCLUDING REFERENCE DESIGNS), APPLICATION OR OTHER DESIGN ADVICE, WEB TOOLS, SAFETY INFORMATION, AND OTHER RESOURCES “AS IS” AND WITH ALL FAULTS, AND DISCLAIMS ALL WARRANTIES, EXPRESS OR IMPLIED, INCLUDING, WITHOUT LIMITATION, ANY IMPLIED WARRANTIES OF MERCHANTABILITY, FITNESS FOR A PARTICULAR PURPOSE, OR NON-INFRINGEMENT OF THIRD-PARTY INTELLECTUAL PROPERTY RIGHTS.

These resources are intended for developers who are designing with Renesas products. You are solely responsible for (1) selecting the appropriate products for your application, (2) designing, validating, and testing your application, and (3) ensuring your application meets applicable standards, and any other safety, security, or other requirements. These resources are subject to change without notice. Renesas grants you permission to use these resources only to develop an application that uses Renesas products. Other reproduction or use of these resources is strictly prohibited. No license is granted to any other Renesas intellectual property or to any third-party intellectual property. Renesas disclaims responsibility for, and you will fully indemnify Renesas and its representatives against, any claims, damages, costs, losses, or liabilities arising from your use of these resources. Renesas' products are provided only subject to Renesas' Terms and Conditions of Sale or other applicable terms agreed to in writing. No use of any Renesas resources expands or otherwise alters any applicable warranties or warranty disclaimers for these products.

(Disclaimer Rev.1.01 Jan 2024)

Corporate Headquarters

TOYOSU FORESIA, 3-2-24 Toyosu,
Koto-ku, Tokyo 135-0061, Japan
www.renesas.com

Trademarks



Renesas and the Renesas logo are trademarks of Renesas Electronics Corporation. All trademarks and registered trademarks are the property of their respective owners.

Contact Information

For further information on a product, technology, the most up-to-date version of a document, or your nearest sales office, please visit www.renesas.com/contact-us/.

Looking for pricing, stock, or lifecycle information?

Click below to explore more details on WIN SOURCE:

-  [View ICS85222AM-02LFT on WIN SOURCE](#)
-  [Renesas Electronics America](#) Information

Optimize Your Supply Chain with WIN SOURCE Solutions

-  Global Sourcing Solution
-  Obsolete Management
-  Cost Control Management
-  Shortage Management
-  Alternative Solution
-  Excess Inventory Management