



**THE DATASHEET OF  
BD8388FV-ME2**



Serial-in Parallel-out LED Driver

# 8ch LED Driver IC for Automotive with 3-line Serial Interface

**BD8388FV-M**

**General Description**

The BD8388FV-M is a serial-in parallel-out controlled LED driver with 40 V output voltage rating. With the input of 3-line serial data, it turns the 8ch open drain output on/off. Due to its compact size, it is optimal for small space.

**Features**

- AEC-Q100 Qualified (Note 1)
- Open Drain Output
- 3-line Serial Control + Enable Signal
- Cascade Connection Compatible
- SSOP-B16 Package
- Internal 8ch Power Transistor
- Output Slew Rate 20 V/μs(Typ)  
(for Low EMC Noise)

(Note 1) Grade 1

**Application**

- For Indicator of Cluster Panel

**Key Specifications**

- Input Voltage Range: 3.0 V to 5.5 V
- Output Voltage Range: 40 V(Max)
- DC Output Current: 50 mA(Max)
- Output ON Resistance: 6 Ω(Typ)
- Static Current: 0 μA(Typ)
- Operating Temperature Range: -40 °C to +125 °C

**Package**

SSOP-B16

W(Typ) x D(Typ) x H(Max)  
5.00 mm x 6.40 mm x 1.35 mm

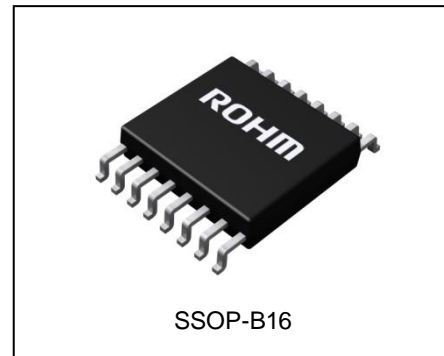

**Typical Application Circuit**

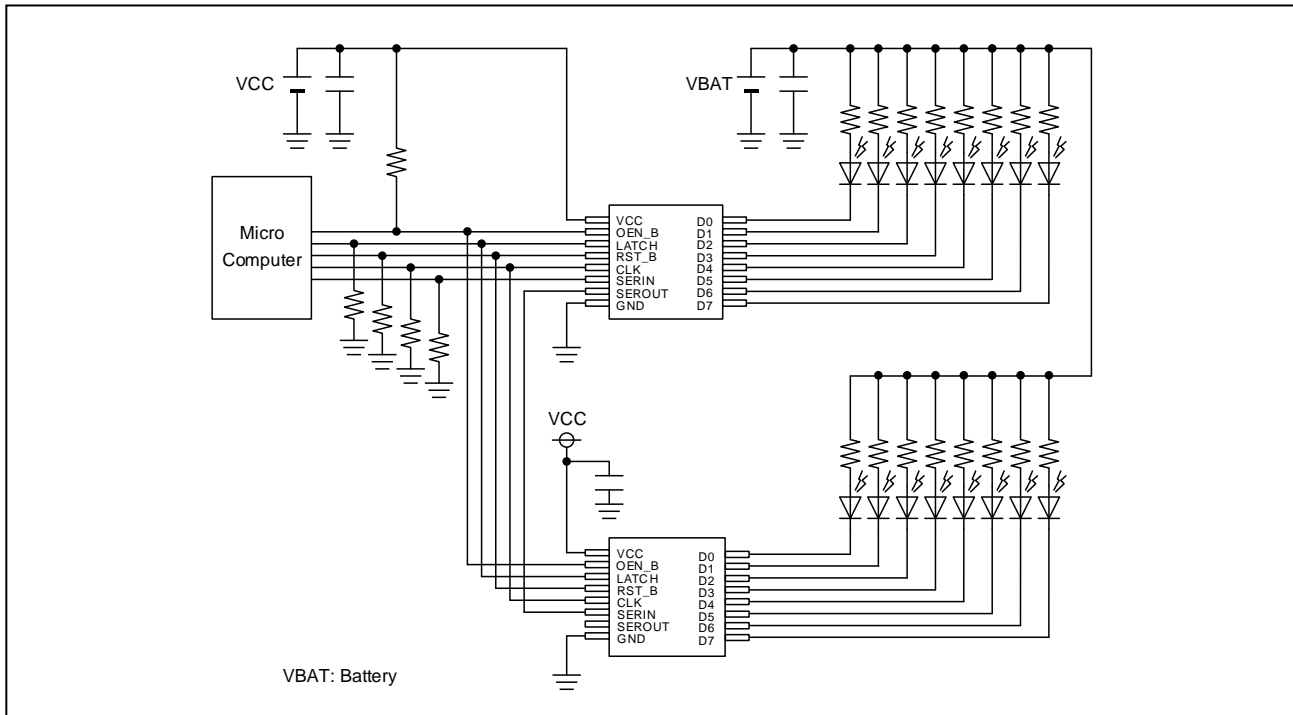

Figure 1. Typical Application Circuit

○Product structure : Silicon monolithic integrated circuit ○This product has no designed protection against radioactive rays

Pin Configuration

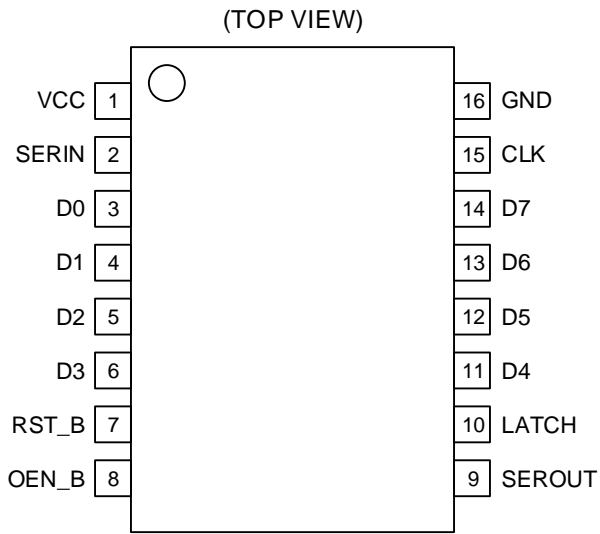

Figure 2. Pin Configuration

Pin Descriptions

Pin No.	Pin Name	Function
1	VCC	Power supply voltage input
2	SERIN	Serial data input
3	D0	Drain output 0
4	D1	Drain output 1
5	D2	Drain output 2
6	D3	Drain output 3
7	RST_B	Reset invert input (Low: Shift register data 0)
8	OEN_B	Output enable (High: Output OFF)
9	SEROUT	Serial data output
10	LATCH	Latch signal input (High: Data latch)
11	D4	Drain output 4
12	D5	Drain output 5
13	D6	Drain output 6
14	D7	Drain output 7
15	CLK	Clock input
16	GND	GND

Block Diagram

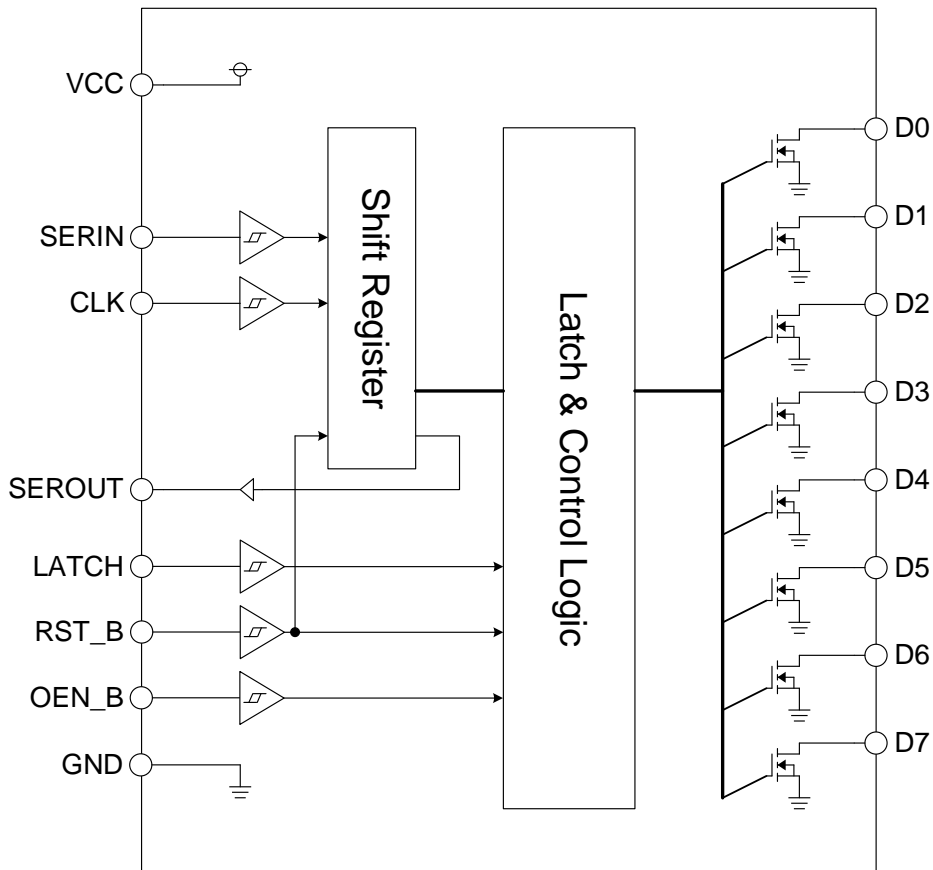

Figure 3. Block Diagram

**Description of Function**

If there is no description, please refer as typical value.

**1. Serial Communication**

The serial I/F is composed of a shift register which changes the CLK and SERIN serial signals to parallel signals, and a register to store those signals with a LATCH signal. The registers are reset by applying a voltage below  $V_{TL}$  to the RST\_B pin, and D7 to D0 become open. To prevent erroneous LED lighting, please apply voltage below  $V_{TL}$  to RST\_B during start-up.

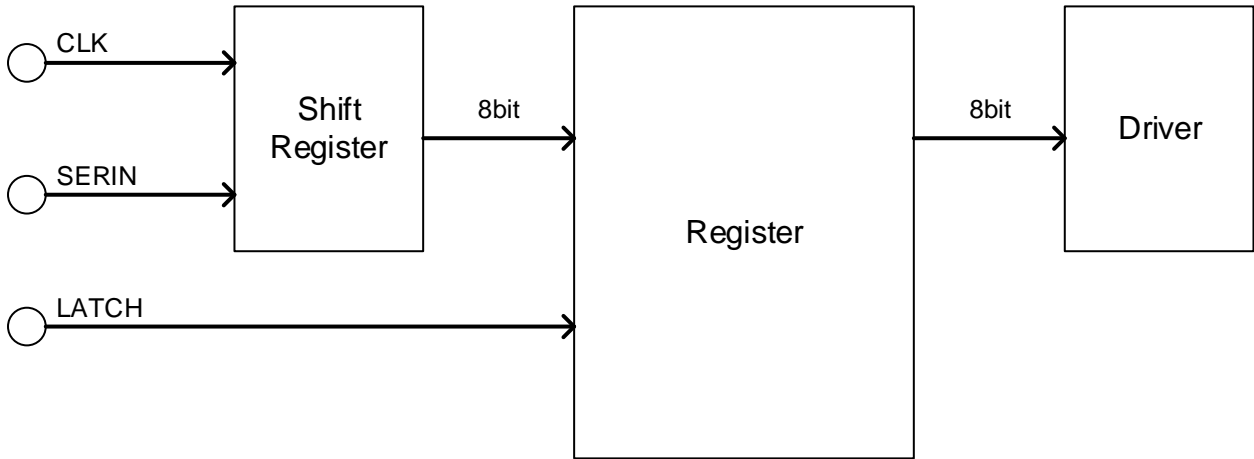

Figure 4. Block Diagram of Serial Communication

(1) Serial Communication Timing

The 8bit serial data input from the SERIN pin is taken into the shift register by the rising edge of the CLK signal, and is recorded in the register by the rising edge of the LATCH signal. The recorded data is valid until the next rising edge of the LATCH signal.

(2) Serial Communication Data

The serial data input configuration of the SERIN pin is shown below:

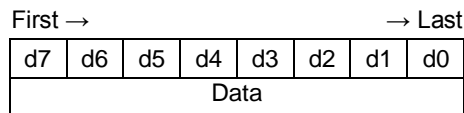

Pin	Output Condition	Data							
		d7	d6	d5	d4	d3	d2	d1	d0
D7	ON	1	*	*	*	*	*	*	*
	OFF	0	*	*	*	*	*	*	*
D6	ON	*	1	*	*	*	*	*	*
	OFF	*	0	*	*	*	*	*	*
D5	ON	*	*	1	*	*	*	*	*
	OFF	*	*	0	*	*	*	*	*
D4	ON	*	*	*	1	*	*	*	*
	OFF	*	*	*	0	*	*	*	*
D3	ON	*	*	*	*	1	*	*	*
	OFF	*	*	*	*	0	*	*	*
D2	ON	*	*	*	*	*	1	*	*
	OFF	*	*	*	*	*	0	*	*
D1	ON	*	*	*	*	*	*	1	*
	OFF	*	*	*	*	*	*	0	*
D0	ON	*	*	*	*	*	*	*	1
	OFF	*	*	*	*	*	*	*	0

\* Indicate don't care.

Description of Function - continued

(3) Enable Signal

By applying voltage  $V_{TH}$  or more to the OEN\_B pin, D7 to D0 become open forcibly.  
 All output terminals become PWM operation by having the PWM signal to the OEN\_B pin at the same time.

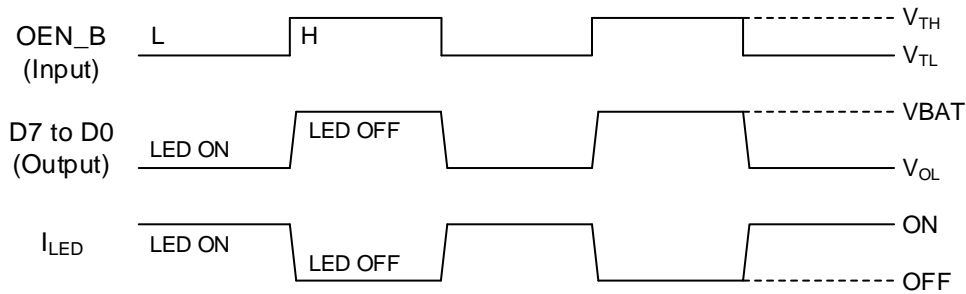

Figure 5. PWM Dimming Control

(4) SEROUT

A cascade connection can be made (connecting at least 2 or more IC's in serial). Serial signal input from SERIN is transferred into the receiver IC by the falling edge of the CLK signal. Since this functionality gives enough margins for the setup time prior to the rising edge of the CLK signal on the receiver IC (using the exact same CLK signal of the sender IC), the application reliability can be improved as cascade connection functionality.

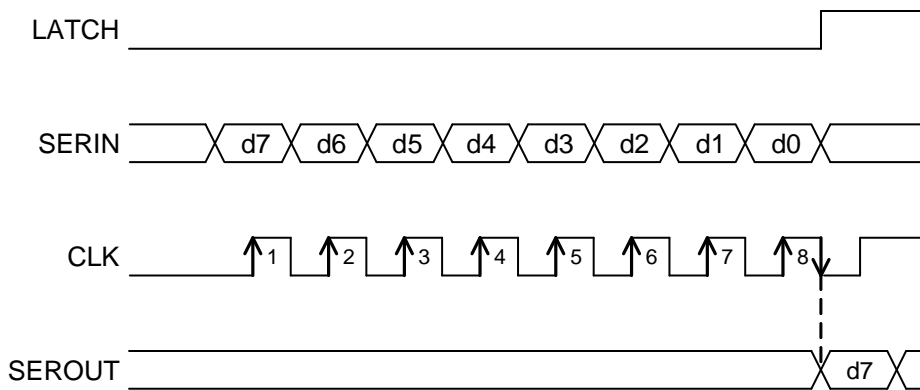

Figure 6. SEROUT Output Signal

2. Cascade Connection

As an application, BD8388FV-M can turn on 9 or more LED lights. By making a cascade connection between 2 ICs, the LED application of up to 16 lights can be constructed. In this case, connect the SEROUT pin of the sender IC and the SERIN pin of the receiver IC. When send 16bit signal to the sender IC, the serial data is sent to the receiver IC from the SEROUT pin of the sender IC. In addition, it is possible to construct 3 or more applications.

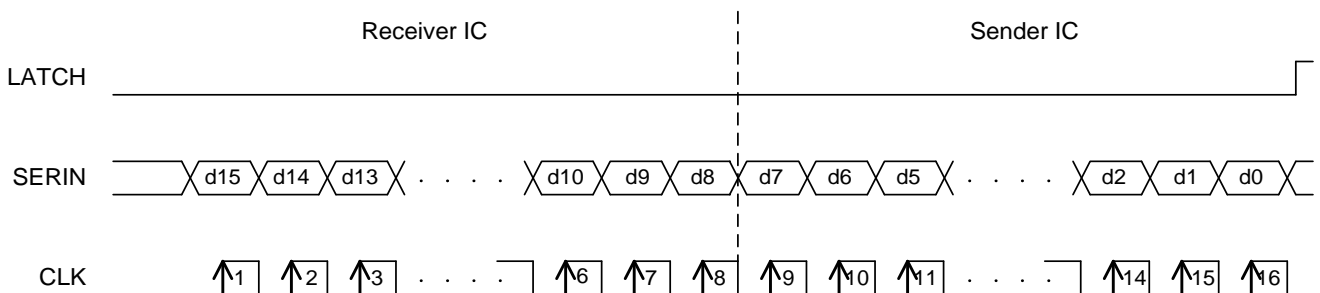

Figure 7. Cascade Connection

## Absolute Maximum Ratings (Ta=-40 °C to +125 °C)

Parameter	Symbol	Rating	Unit
Power Supply Voltage	VCC	-0.3 to +7	V
Output Pin Voltage (D0, D1, D2, D3, D4, D5, D6, D7)	V <sub>D0</sub> , V <sub>D1</sub> , V <sub>D2</sub> , V <sub>D3</sub> , V <sub>D4</sub> , V <sub>D5</sub> , V <sub>D6</sub> , V <sub>D7</sub>	-0.3 to +40	V
SERIN, RST_B, CLK, OEN_B, LATCH Pin Voltage	V <sub>SERIN</sub> , V <sub>RST_B</sub> , V <sub>CLK</sub> , V <sub>OEN_B</sub> , V <sub>LATCH</sub>	-0.3 to +VCC	V
SEROUT Pin Voltage	V <sub>SEROUT</sub>	-0.3 to +VCC	V
Power Dissipation <sup>(Note 1)</sup>	Pd	887	mW
Storage Temperature Range	Tstg	-55 to +150	°C
DC Output Current	I <sub>OMAX_DC</sub>	50	mA
Pulse Output Current <sup>(Note 2)</sup>	I <sub>OMAX_PLS</sub>	150	mA
Maximum Junction Temperature	Tjmax	150	°C

**Caution 1:** Operating the IC over the absolute maximum ratings may damage the IC. The damage can either be a short circuit between pins or an open circuit between pins and the internal circuitry. Therefore, it is important to consider circuit protection measures, such as adding a fuse, in case the IC is operated over the absolute maximum ratings.

**Caution 2:** Should by any chance the maximum junction temperature rating be exceeded the rise in temperature of the chip may result in deterioration of the properties of the chip. In case of exceeding this absolute maximum rating, design a PCB with thermal resistance taken into consideration by increasing board size and copper area so as not to exceed the maximum junction temperature rating.

(Note 1) Pd decreased at 7.5 mW/°C for temperatures Ta=25 °C or more, mounted on 70 mm x 70 mm x 1.6 mm Glass-epoxy PCB.

(Note 2) Do not exceed Pd. Time to impress ≤ 200 ms.

Thermal Resistance<sup>(Note 3)</sup>

Parameter	Symbol	Thermal Resistance (Typ)		Unit
		1s <sup>(Note 5)</sup>	2s2p <sup>(Note 6)</sup>	
SSOP-B16				
Junction to Ambient	θ <sub>JA</sub>	140.9	77.2	°C/W
Junction to Top Characterization Parameter <sup>(Note 4)</sup>	Ψ <sub>JT</sub>	6	5	°C/W

(Note 3) Based on JESD51-2A(Still-Air).

(Note 4) The thermal characterization parameter to report the difference between junction temperature and the temperature at the top center of the outside surface of the component package.

(Note 5) Using a PCB board based on JESD51-3.

(Note 6) Using a PCB board based on JESD51-7.

Layer Number of Measurement Board	Material	Board Size			
Single	FR-4	114.3 mm x 76.2 mm x 1.57 mmt			
Top					
Copper Pattern	Thickness				
Footprints and Traces	70 μm				
Layer Number of Measurement Board					
4 Layers	FR-4	114.3 mm x 76.2 mm x 1.6 mmt			
Top					
		2 Internal Layers		Bottom	
Copper Pattern	Thickness	Copper Pattern	Thickness	Copper Pattern	Thickness
Footprints and Traces	70 μm	74.2 mm x 74.2 mm	35 μm	74.2 mm x 74.2 mm	70 μm

## Recommended Operating Conditions

Parameter	Symbol	Min	Typ	Max	Unit
Power Supply Voltage	VCC	3.0	-	5.5	V
Operating Temperature	Topr	-40	-	+125	°C

## Electrical Characteristics (Unless otherwise specified VCC=3.0 V to 5.5 V, Ta=-40 °C to +125 °C)

Parameter	Symbol	Limit			Unit	Condition
		Min	Typ	Max		
<b>Output D0 to D7</b>						
ON Resistance 1 <sup>(Note 1)</sup>	R <sub>ON1</sub>	-	6	12	Ω	I <sub>Dn</sub> =20 mA, 4.5 V ≤ VCC ≤ 5.5 V
ON Resistance 2 <sup>(Note 1)</sup>	R <sub>ON2</sub>	-	9	18	Ω	I <sub>Dn</sub> =20 mA, 3.0 V ≤ VCC < 4.5 V
Output Leakage Current <sup>(Note 2)</sup>	I <sub>DL</sub>	-	-	0.3	μA	V <sub>Dn</sub> =39 V
<b>Logic Input</b>						
Upper Limit Threshold Voltage	V <sub>TH</sub>	VCC x 0.7	-	-	V	
Bottom Limit Threshold Voltage	V <sub>TL</sub>	-	-	VCC x 0.2	V	
Serial Clock Frequency	f <sub>CLK</sub>	-	-	1.25	MHz	
Input Leakage Current L	I <sub>INLL</sub>	-5	0	-	μA	V <sub>TL</sub> =0 V
Input Leakage Current H	I <sub>INLH</sub>	-	0	5	μA	V <sub>TH</sub> =5 V
<b>WHOLE</b>						
Circuit Current	I <sub>CC</sub>	-	0.05	1	mA	Serial Data Input, VCC=5.0 V, f <sub>CLK</sub> =500 kHz, V <sub>TH</sub> =VCC, V <sub>TL</sub> =0 V, SEROUT=OPEN
Static Current	I <sub>STN</sub>	-	0	50	μA	SEROUT=OPEN
<b>SEROUT</b>						
Output Voltage High 1 <sup>(Note 3)</sup>	V <sub>OH1</sub>	4.6	4.8	-	V	VCC=5.0 V, I <sub>SO</sub> =-4 mA
Output Voltage Low 1 <sup>(Note 3)</sup>	V <sub>OL1</sub>	-	0.2	0.4	V	VCC=5.0 V, I <sub>SO</sub> =4 mA
Output Voltage High 2 <sup>(Note 3)</sup>	V <sub>OH2</sub>	2.7	3.0	-	V	VCC=3.3 V, I <sub>SO</sub> =-4 mA
Output Voltage Low 2 <sup>(Note 3)</sup>	V <sub>OL2</sub>	-	0.3	0.6	V	VCC=3.3 V, I <sub>SO</sub> =4 mA

(Note 1) I<sub>Dn</sub>: Current flowing to the output Dn pin. (n: 0 to 7)(Note 2) V<sub>Dn</sub>: Output Dn pin voltage. (n: 0 to 7)(Note 3) I<sub>SO</sub>: Current flowing to the SEROUT pin.

Typical Performance Curves

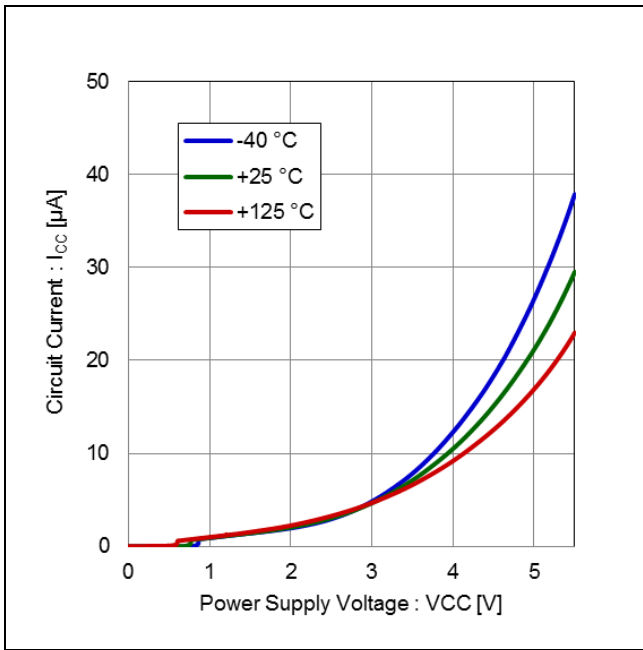

Figure 8. Circuit Current vs Power Supply Voltage

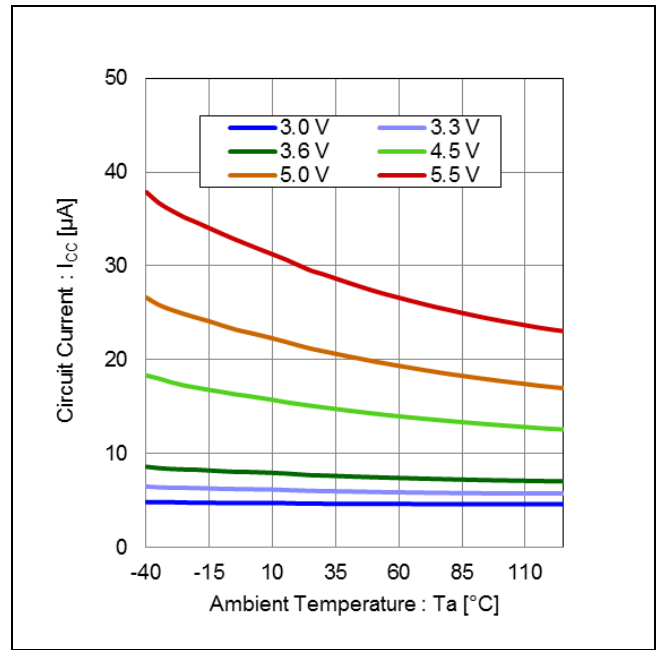

Figure 9. Circuit Current vs Ambient Temperature

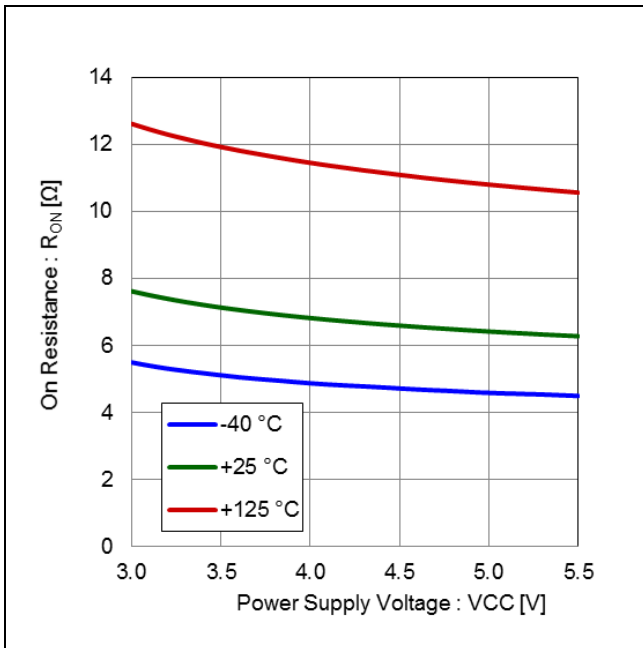

Figure 10. On Resistance vs Power Supply Voltage  
 (@ $I_{Dn}^{(Note\ 1)}$ =20 mA)

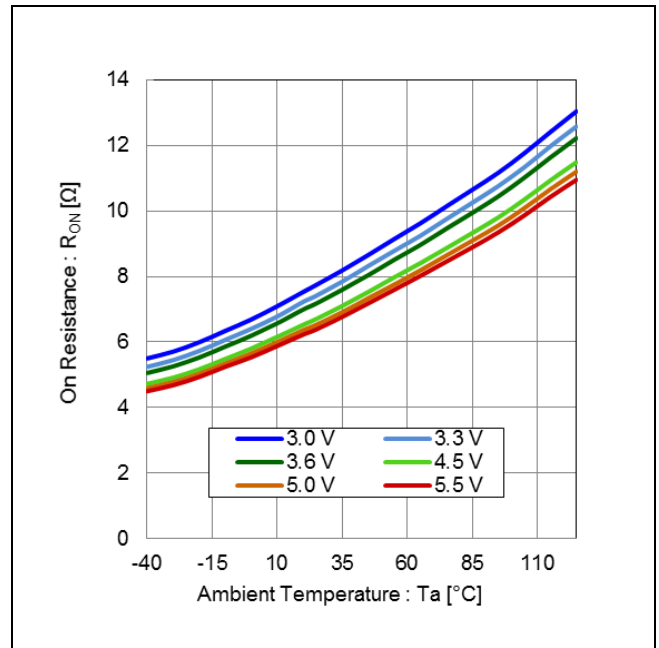

Figure 11. On Resistance vs Ambient Temperature  
 (@ $I_{Dn}^{(Note\ 1)}$ =20 mA)

(Note 1)  $I_{Dn}$  : Current flowing to the output Dn pin. (n: 0 to 7)

Typical Performance Curves - continued

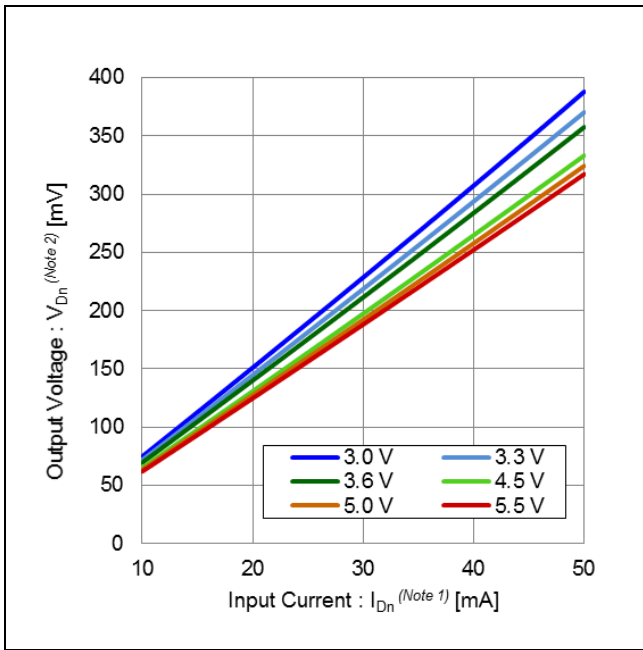

Figure 12. Output Voltage vs Input Current

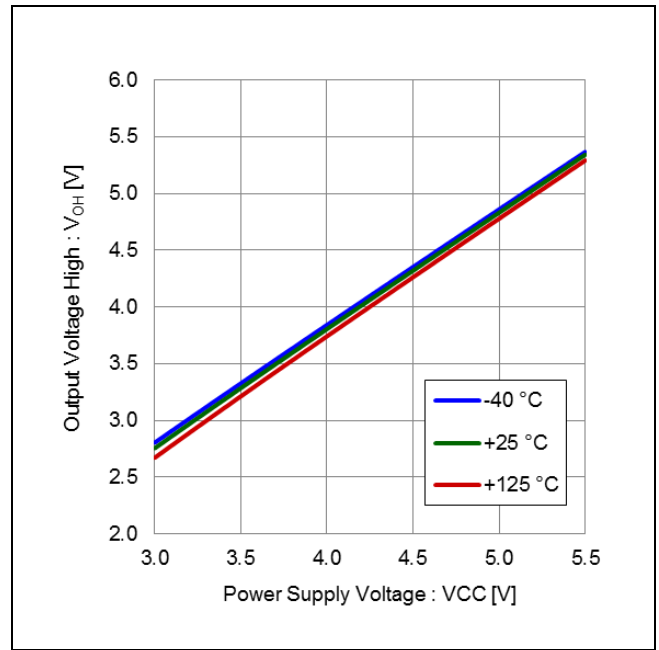

Figure 13. Output Voltage High vs Power Supply Voltage (@I<sub>SO</sub> = -4 mA)

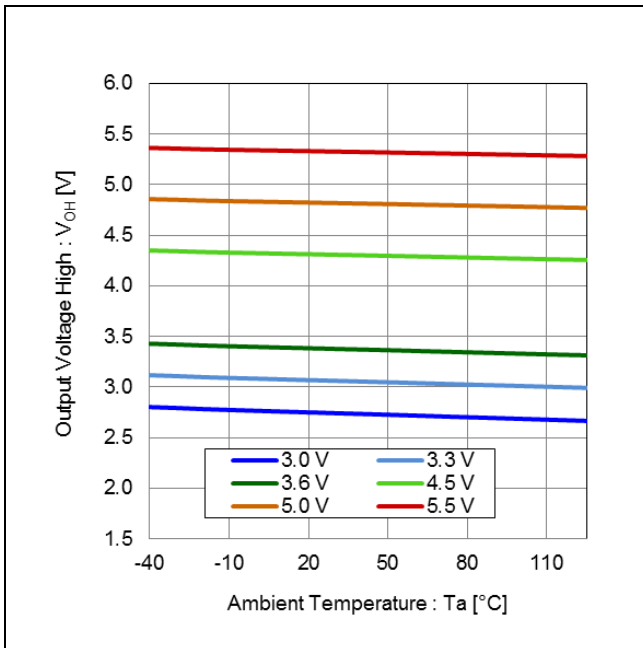

Figure 14. Output Voltage High vs Ambient Temperature (@I<sub>SO</sub> = -4 mA)

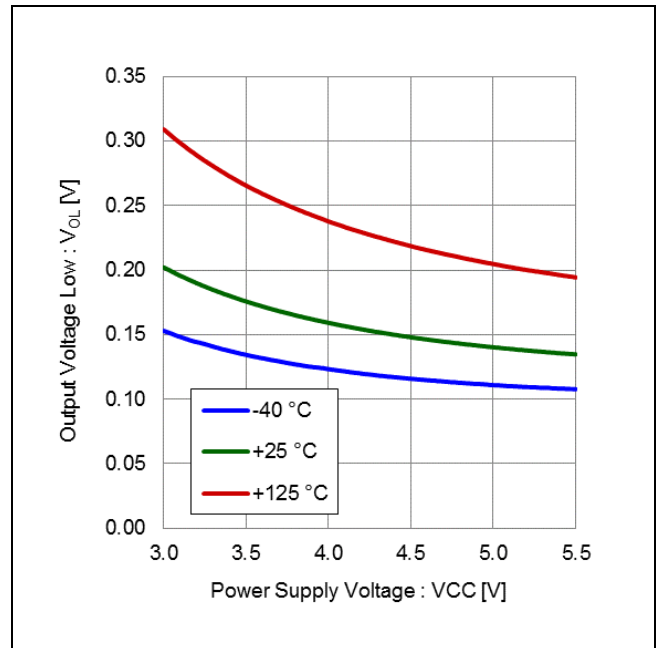

Figure 15. Output Voltage Low vs Power Supply Voltage (@I<sub>SO</sub> = 4 mA)

(Note 1) I<sub>Dn</sub>: Current flowing to the output Dn pin. (n: 0 to 7)

(Note 2) V<sub>Dn</sub>: Output Dn pin voltage. (n: 0 to 7)

(Note 3) I<sub>SO</sub>: Current flowing to the SEROUT pin.

Typical Performance Curves - continued

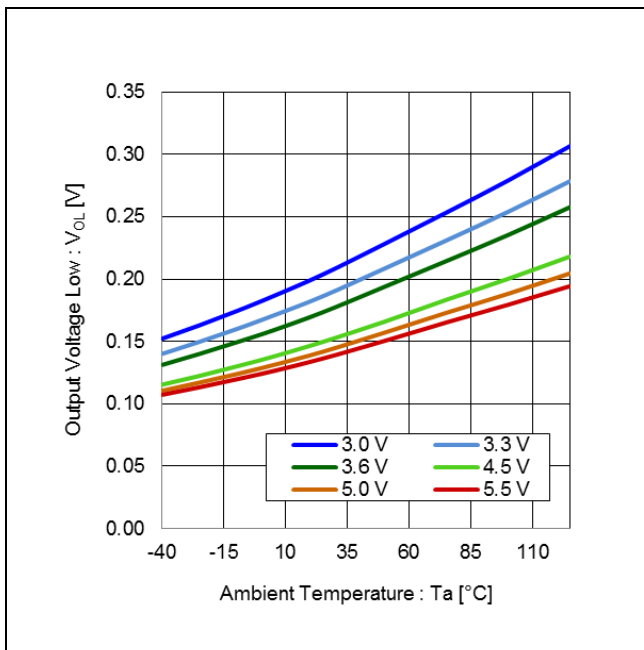

Figure 16. Output Voltage Low vs Ambient Temperature  
 (@I<sub>SO</sub> (Note 1)=4 mA)

(Note 1) I<sub>bn</sub> : Current flowing to the output Dn pin. (n: 0 to 7)

Input Signal's Timing Chart

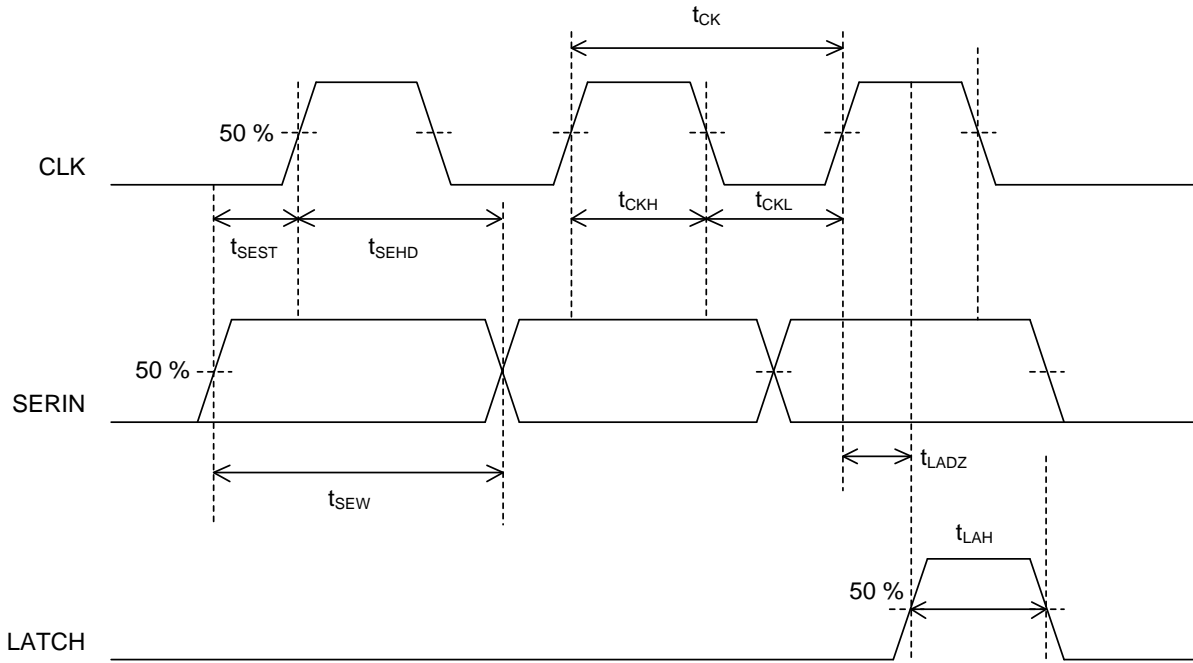

Figure 17. Timing Chart of Input Signal

Input Signal's Timing Rule (Ta=-40 °C to +125 °C, VCC=3.0 V to 5.5 V)

Parameter	Symbol	Min	Unit
CLK Period	$t_{CK}$	800	ns
CLK High Pulse Width	$t_{CKH}$	380	ns
CLK Low Pulse Width	$t_{CKL}$	380	ns
SERIN High and Low Pulse Width	$t_{SEW}$	780	ns
SERIN Setup Time	$t_{SEST}$	150	ns
SERIN Hold Time	$t_{SEHD}$	150	ns
LATCH High Pulse Time	$t_{LAH}$	380	ns
D0 to D7 Output Pin Setup Time	$t_{LADZ}$	200	ns

Output Signal's Timing Chart

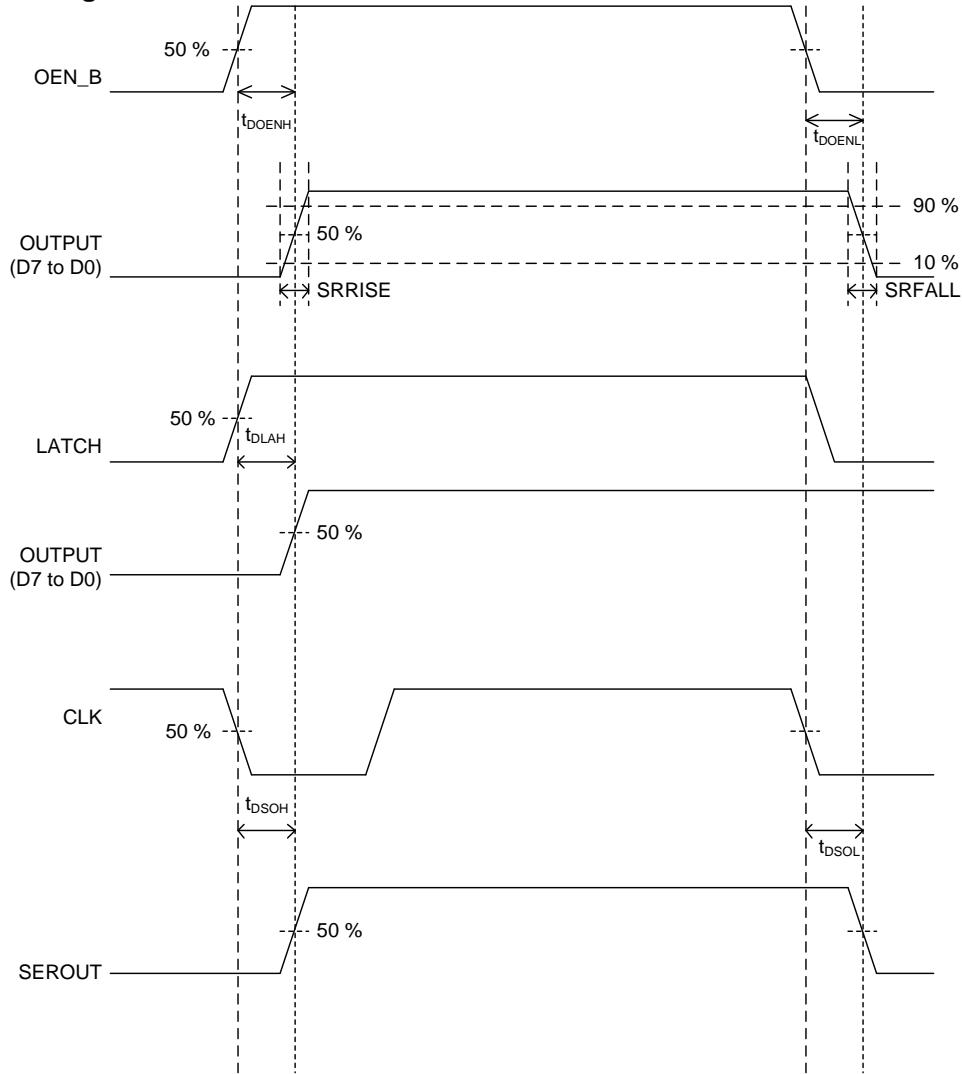

Figure 18. Timing Chart of Output Signal

Output Signal's Delay Time (Ta=-40 °C to +125 °C, VCC=3.0 V to 5.5 V)

Parameter	Symbol	Min	Typ	Max	Unit	Condition
OEN_B Switching Time (Low→High)	$t_{DOENH}$	-	-	3000	ns	
OEN_B Switching Time (High→Low)	$t_{DOENL}$	-	-	2000	ns	
LATCH Switching Delay Time	$t_{DLAH}$	-	-	3000	ns	
SEROUT Propagation Delay Time (Low→High)	$t_{DSOH}$	-	-	350	ns	
SEROUT Propagation Delay Time (High→Low)	$t_{DSOL}$	-	-	350	ns	
Output Rising Slew Rate <sup>(Note 1)</sup>	SRRISE	-	20	-	V/μs	Ta=25 °C, VCC=5 V, RL=500 Ω, VBAT=10 V
Output Falling Slew Rate <sup>(Note 1)</sup>	SRFALL	-	20	-	V/μs	Ta=25 °C, VCC=5 V, RL=500 Ω, VBAT=10 V

(Note 1) Please refer to the application circuit example on P.12 for measurement conditions. However, LED load is not used and it is shorted.

Application Example

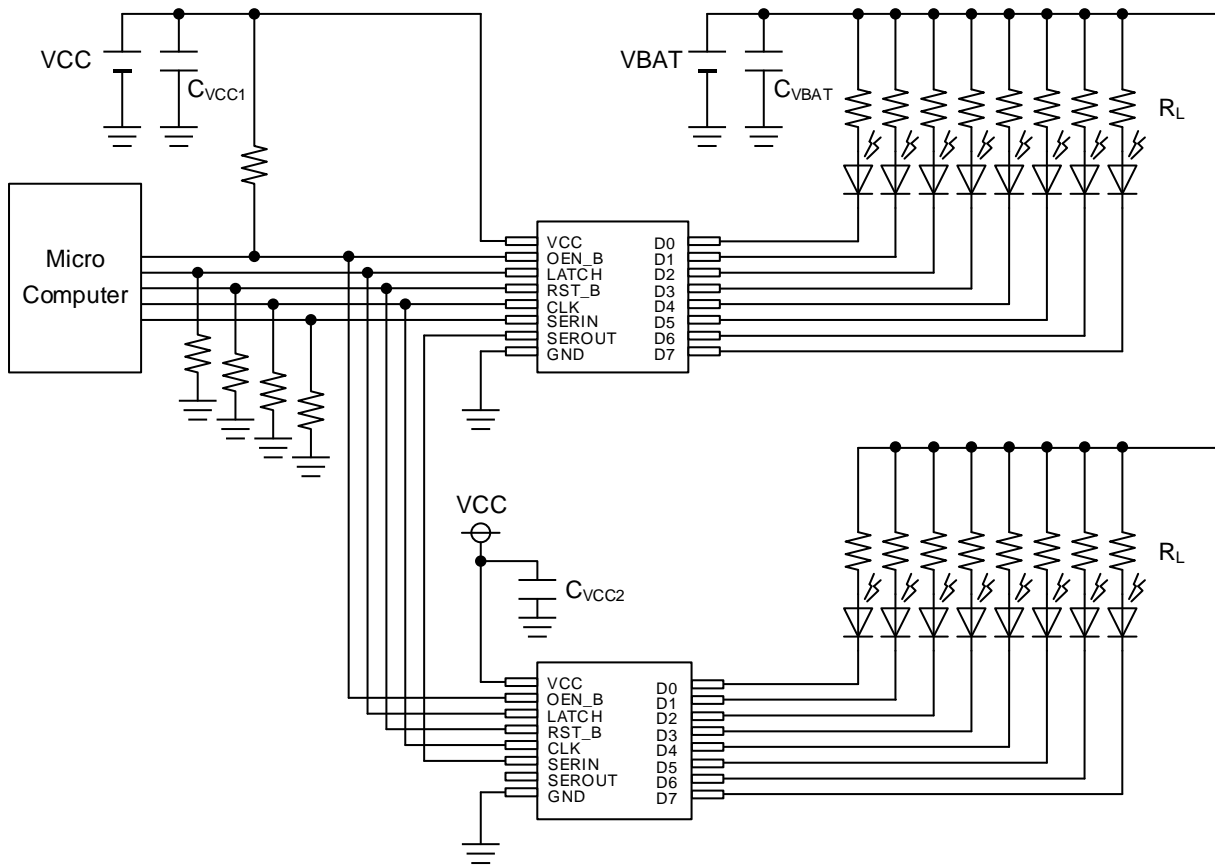
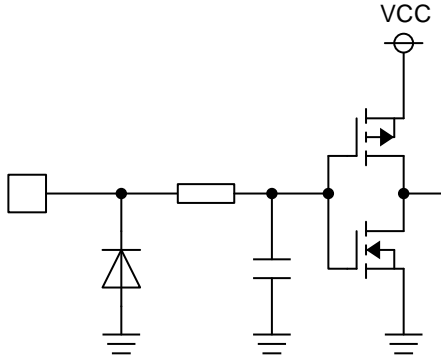
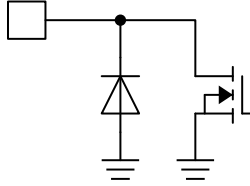
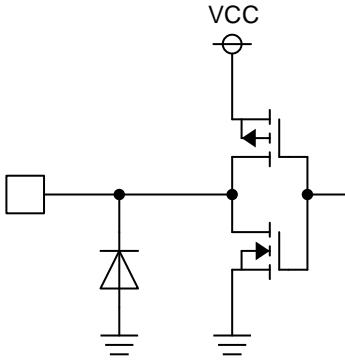

Figure 19. Application Example

Component Name	Component Value	Product Name	Manufacturer
C <sub>VCC1</sub>	0.1 μF	GCM155R11A104KA01	murata
C <sub>VCC2</sub>	0.1 μF	GCM155R11A104KA01	murata
C <sub>VBAT</sub>	4.7 μF	GCM32ER71H475KA40	murata
R <sub>L</sub>	620 Ω	ESR10EZPJ621	Rohm

I/O Equivalence Circuit

<p>2. SERIN 10. LATCH</p>	<p>7. RST_B 15. CLK</p>	<p>8. OEN_B</p> <p>3. D0 11. D4</p> <p>4. D1 12. D5</p> <p>5. D2 13. D6</p> <p>6. D3 14. D7</p>
		
<p>11. SEROUT</p>		
		

## Operational Notes

### 1. Reverse Connection of Power Supply

Connecting the power supply in reverse polarity can damage the IC. Take precautions against reverse polarity when connecting the power supply, such as mounting an external diode between the power supply and the IC's power supply pins.

### 2. Power Supply Lines

Design the PCB layout pattern to provide low impedance supply lines. Furthermore, connect a capacitor to ground at all power supply pins. Consider the effect of temperature and aging on the capacitance value when using electrolytic capacitors.

### 3. Ground Voltage

Ensure that no pins are at a voltage below that of the ground pin at any time, even during transient condition.

### 4. Ground Wiring Pattern

When using both small-signal and large-current ground traces, the two ground traces should be routed separately but connected to a single ground at the reference point of the application board to avoid fluctuations in the small-signal ground caused by large currents. Also ensure that the ground traces of external components do not cause variations on the ground voltage. The ground lines must be as short and thick as possible to reduce line impedance.

### 5. Recommended Operating Conditions

The function and operation of the IC are guaranteed within the range specified by the recommended operating conditions. The characteristic values are guaranteed only under the conditions of each item specified by the electrical characteristics.

### 6. Inrush Current

When power is first supplied to the IC, it is possible that the internal logic may be unstable and inrush current may flow instantaneously due to the internal powering sequence and delays, especially if the IC has more than one power supply. Therefore, give special consideration to power coupling capacitance, power wiring, width of ground wiring, and routing of connections.

### 7. Testing on Application Boards

When testing the IC on an application board, connecting a capacitor directly to a low-impedance output pin may subject the IC to stress. Always discharge capacitors completely after each process or step. The IC's power supply should always be turned off completely before connecting or removing it from the test setup during the inspection process. To prevent damage from static discharge, ground the IC during assembly and use similar precautions during transport and storage.

### 8. Inter-pin Short and Mounting Errors

Ensure that the direction and position are correct when mounting the IC on the PCB. Incorrect mounting may result in damaging the IC. Avoid nearby pins being shorted to each other especially to ground, power supply and output pin. Inter-pin shorts could be due to many reasons such as metal particles, water droplets (in very humid environment) and unintentional solder bridge deposited in between pins during assembly to name a few.

### 9. Unused Input Pins

Input pins of an IC are often connected to the gate of a MOS transistor. The gate has extremely high impedance and extremely low capacitance. If left unconnected, the electric field from the outside can easily charge it. The small charge acquired in this way is enough to produce a significant effect on the conduction through the transistor and cause unexpected operation of the IC. So unless otherwise specified, unused input pins should be connected to the power supply or ground line.

Operational Notes - continued

10. Regarding the Input Pin of the IC

This monolithic IC contains P+ isolation and P substrate layers between adjacent elements in order to keep them isolated. P-N junctions are formed at the intersection of the P layers with the N layers of other elements, creating a parasitic diode or transistor. For example (refer to figure below):

When  $GND > Pin A$  and  $GND > Pin B$ , the P-N junction operates as a parasitic diode.

When  $GND > Pin B$ , the P-N junction operates as a parasitic transistor.

Parasitic diodes inevitably occur in the structure of the IC. The operation of parasitic diodes can result in mutual interference among circuits, operational faults, or physical damage. Therefore, conditions that cause these diodes to operate, such as applying a voltage lower than the GND voltage to an input pin (and thus to the P substrate) should be avoided.

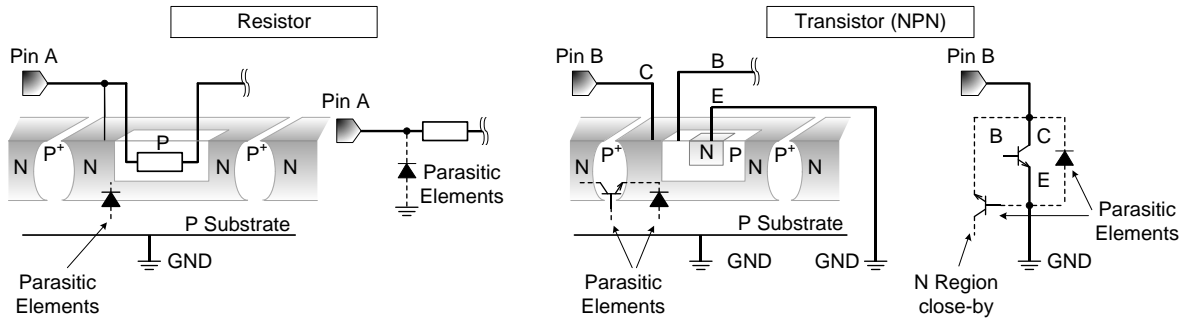

Figure 20. Example of Monolithic IC Structure

11. Ceramic Capacitor

When using a ceramic capacitor, determine a capacitance value considering the change of capacitance with temperature and the decrease in nominal capacitance due to DC bias and others.

Ordering Information

B	D	8	3	8	8	F	V	-	ME	2
---	---	---	---	---	---	---	---	---	----	---

Package  
FV: SSOP-B16

Product Rank  
M: for Automotive  
Packaging and forming specification  
E2: Embossed tape and reel  
(SSOP-B16)

Marking Diagram

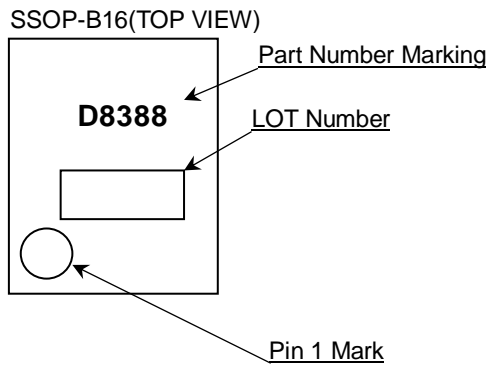

Physical Dimension and Packing Information

Package Name	SSOP-B16
--------------	----------

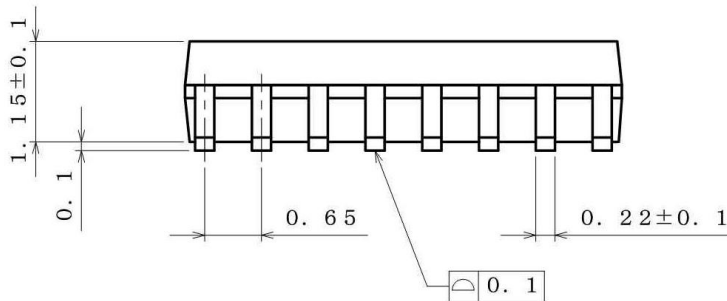
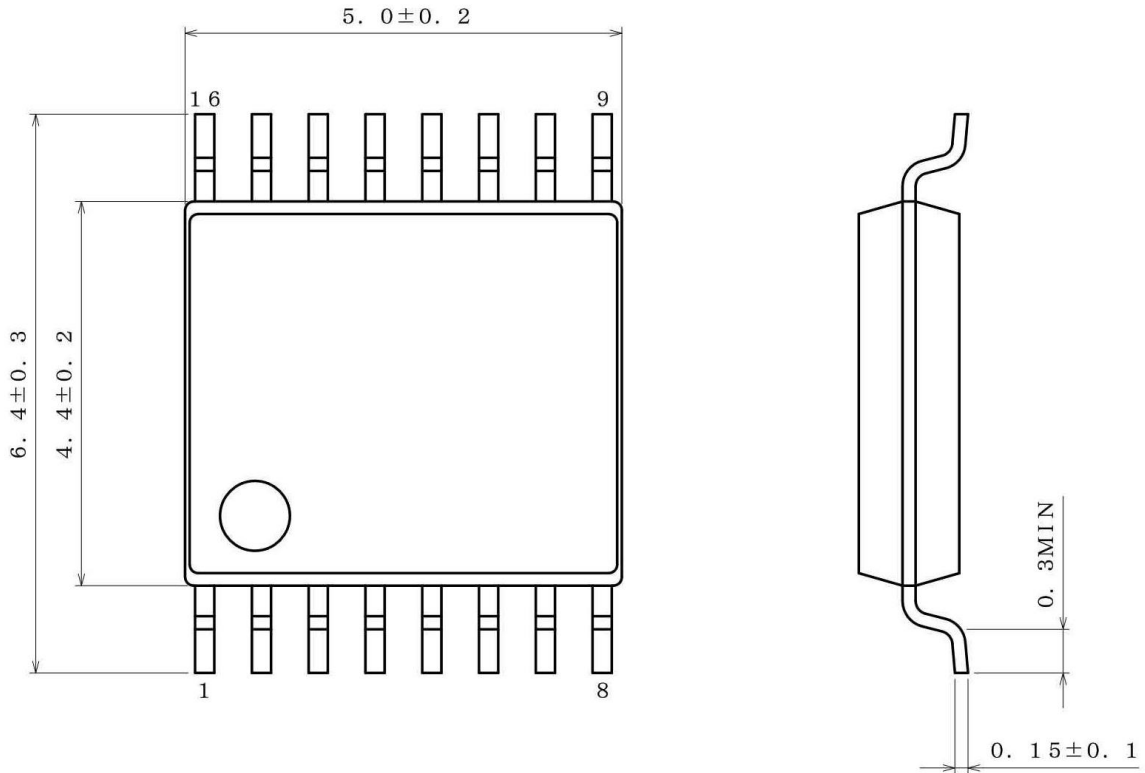

(UNIT : mm)  
 PKG : SSOP-B16  
 Drawing No. B0771

<Tape and Reel information>

Tape	Embossed carrier tape
Quantity	2500pcs
Direction of feed	E2 ( The direction is the 1pin of product is at the upper left when you hold reel on the left hand and you pull out the tape on the right hand )

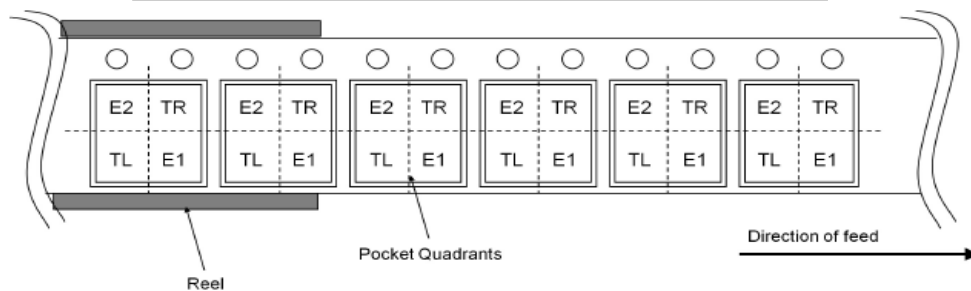

**Revision History**

Date	Rev.	Changes
01.Aug.2018	001	New release of specification.

# Notice

## Precaution on using ROHM Products

1. If you intend to use our Products in devices requiring extremely high reliability (such as medical equipment <sup>(Note 1)</sup>, aircraft/spacecraft, nuclear power controllers, etc.) and whose malfunction or failure may cause loss of human life, bodily injury or serious damage to property ("Specific Applications"), please consult with the ROHM sales representative in advance. Unless otherwise agreed in writing by ROHM in advance, ROHM shall not be in any way responsible or liable for any damages, expenses or losses incurred by you or third parties arising from the use of any ROHM's Products for Specific Applications.

(Note1) Medical Equipment Classification of the Specific Applications

JAPAN	USA	EU	CHINA
CLASS III	CLASS III	CLASS II b	CLASS III
CLASS IV		CLASS III	

2. ROHM designs and manufactures its Products subject to strict quality control system. However, semiconductor products can fail or malfunction at a certain rate. Please be sure to implement, at your own responsibilities, adequate safety measures including but not limited to fail-safe design against the physical injury, damage to any property, which a failure or malfunction of our Products may cause. The following are examples of safety measures:
  - [a] Installation of protection circuits or other protective devices to improve system safety
  - [b] Installation of redundant circuits to reduce the impact of single or multiple circuit failure
3. Our Products are not designed under any special or extraordinary environments or conditions, as exemplified below. Accordingly, ROHM shall not be in any way responsible or liable for any damages, expenses or losses arising from the use of any ROHM's Products under any special or extraordinary environments or conditions. If you intend to use our Products under any special or extraordinary environments or conditions (as exemplified below), your independent verification and confirmation of product performance, reliability, etc. prior to use, must be necessary:
  - [a] Use of our Products in any types of liquid, including water, oils, chemicals, and organic solvents
  - [b] Use of our Products outdoors or in places where the Products are exposed to direct sunlight or dust
  - [c] Use of our Products in places where the Products are exposed to sea wind or corrosive gases, including Cl<sub>2</sub>, H<sub>2</sub>S, NH<sub>3</sub>, SO<sub>2</sub>, and NO<sub>2</sub>
  - [d] Use of our Products in places where the Products are exposed to static electricity or electromagnetic waves
  - [e] Use of our Products in proximity to heat-producing components, plastic cords, or other flammable items
  - [f] Sealing or coating our Products with resin or other coating materials
  - [g] Use of our Products without cleaning residue of flux (even if you use no-clean type fluxes, cleaning residue of flux is recommended); or Washing our Products by using water or water-soluble cleaning agents for cleaning residue after soldering
  - [h] Use of the Products in places subject to dew condensation
4. The Products are not subject to radiation-proof design.
5. Please verify and confirm characteristics of the final or mounted products in using the Products.
6. In particular, if a transient load (a large amount of load applied in a short period of time, such as pulse. is applied, confirmation of performance characteristics after on-board mounting is strongly recommended. Avoid applying power exceeding normal rated power; exceeding the power rating under steady-state loading condition may negatively affect product performance and reliability.
7. De-rate Power Dissipation depending on ambient temperature. When used in sealed area, confirm that it is the use in the range that does not exceed the maximum junction temperature.
8. Confirm that operation temperature is within the specified range described in the product specification.
9. ROHM shall not be in any way responsible or liable for failure induced under deviant condition from what is defined in this document.

## Precaution for Mounting / Circuit board design

1. When a highly active halogenous (chlorine, bromine, etc.) flux is used, the residue of flux may negatively affect product performance and reliability.
2. In principle, the reflow soldering method must be used on a surface-mount products, the flow soldering method must be used on a through hole mount products. If the flow soldering method is preferred on a surface-mount products, please consult with the ROHM representative in advance.

For details, please refer to ROHM Mounting specification

### Precautions Regarding Application Examples and External Circuits

1. If change is made to the constant of an external circuit, please allow a sufficient margin considering variations of the characteristics of the Products and external components, including transient characteristics, as well as static characteristics.
2. You agree that application notes, reference designs, and associated data and information contained in this document are presented only as guidance for Products use. Therefore, in case you use such information, you are solely responsible for it and you must exercise your own independent verification and judgment in the use of such information contained in this document. ROHM shall not be in any way responsible or liable for any damages, expenses or losses incurred by you or third parties arising from the use of such information.

### Precaution for Electrostatic

This Product is electrostatic sensitive product, which may be damaged due to electrostatic discharge. Please take proper caution in your manufacturing process and storage so that voltage exceeding the Products maximum rating will not be applied to Products. Please take special care under dry condition (e.g. Grounding of human body / equipment / solder iron, isolation from charged objects, setting of Ionizer, friction prevention and temperature / humidity control).

### Precaution for Storage / Transportation

1. Product performance and soldered connections may deteriorate if the Products are stored in the places where:
  - [a] the Products are exposed to sea winds or corrosive gases, including Cl<sub>2</sub>, H<sub>2</sub>S, NH<sub>3</sub>, SO<sub>2</sub>, and NO<sub>2</sub>
  - [b] the temperature or humidity exceeds those recommended by ROHM
  - [c] the Products are exposed to direct sunshine or condensation
  - [d] the Products are exposed to high Electrostatic
2. Even under ROHM recommended storage condition, solderability of products out of recommended storage time period may be degraded. It is strongly recommended to confirm solderability before using Products of which storage time is exceeding the recommended storage time period.
3. Store / transport cartons in the correct direction, which is indicated on a carton with a symbol. Otherwise bent leads may occur due to excessive stress applied when dropping of a carton.
4. Use Products within the specified time after opening a humidity barrier bag. Baking is required before using Products of which storage time is exceeding the recommended storage time period.

### Precaution for Product Label

A two-dimensional barcode printed on ROHM Products label is for ROHM's internal use only.

### Precaution for Disposition

When disposing Products please dispose them properly using an authorized industry waste company.

### Precaution for Foreign Exchange and Foreign Trade act

Since concerned goods might be fallen under listed items of export control prescribed by Foreign exchange and Foreign trade act, please consult with ROHM in case of export.

### Precaution Regarding Intellectual Property Rights

1. All information and data including but not limited to application example contained in this document is for reference only. ROHM does not warrant that foregoing information or data will not infringe any intellectual property rights or any other rights of any third party regarding such information or data.
2. ROHM shall not have any obligations where the claims, actions or demands arising from the combination of the Products with other articles such as components, circuits, systems or external equipment (including software).
3. No license, expressly or implied, is granted hereby under any intellectual property rights or other rights of ROHM or any third parties with respect to the Products or the information contained in this document. Provided, however, that ROHM will not assert its intellectual property rights or other rights against you or your customers to the extent necessary to manufacture or sell products containing the Products, subject to the terms and conditions herein.

### Other Precaution



1. This document may not be reprinted or reproduced, in whole or in part, without prior written consent of ROHM.
2. The Products may not be disassembled, converted, modified, reproduced or otherwise changed without prior written consent of ROHM.
3. In no event shall you use in any way whatsoever the Products and the related technical information contained in the Products or this document for any military purposes, including but not limited to, the development of mass-destruction weapons.
4. The proper names of companies or products described in this document are trademarks or registered trademarks of ROHM, its affiliated companies or third parties.

**General Precaution**







1. Before you use our Products, you are requested to carefully read this document and fully understand its contents. ROHM shall not be in any way responsible or liable for failure, malfunction or accident arising from the use of any ROHM's Products against warning, caution or note contained in this document.
2. All information contained in this document is current as of the issuing date and subject to change without any prior notice. Before purchasing or using ROHM's Products, please confirm the latest information with a ROHM sales representative.
3. The information contained in this document is provided on an "as is" basis and ROHM does not warrant that all information contained in this document is accurate and/or error-free. ROHM shall not be in any way responsible or liable for any damages, expenses or losses incurred by you or third parties resulting from inaccuracy or errors of or concerning such information.

## Looking for pricing, stock, or lifecycle information?

Click below to explore more details on WIN SOURCE:

-  [View BD8388FV-ME2 on WIN SOURCE](#)
-  [Rohm Semiconductor](#) Information

## Optimize Your Supply Chain with WIN SOURCE Solutions

-  Global Sourcing Solution
-  Obsolete Management
-  Cost Control Management
-  Shortage Management
-  Alternative Solution
-  Excess Inventory Management