



THE DATASHEET OF HMC677LP5E





6-Bit SERIAL/PARALLEL SWITCH DRIVER/CONTROLLER

Typical Applications

The HMC677LP5(E) is ideal for:

- Microwave and Millimeterwave Control Circuits
- Test and Measurement Equipment
- Complex Multi-Function Assemblies
- Military and Space Subsystems
- Transmit/Receive Module Controllers

Features

- Accepts Serial or Parallel Data
- Compatible with TTL and CMOS Logic
- Complementary Outputs
- 6-Bit Control Word
- Power-up State Selection
- Low Power Consumption
- Fast Clock Rate

Functional Diagram

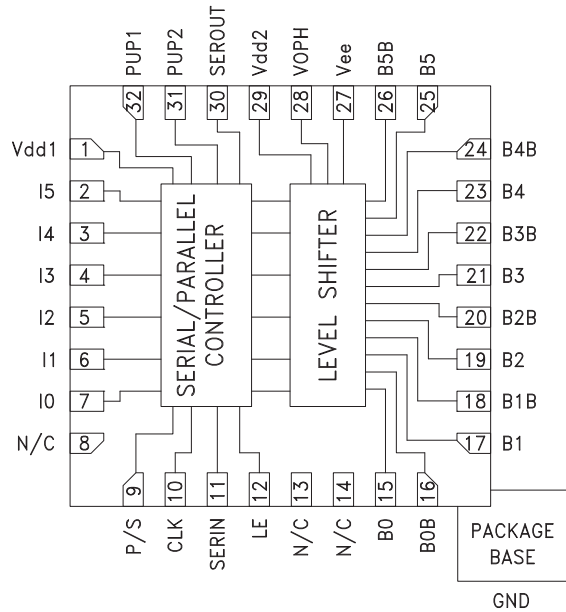

General Description

The HMC677LP5(E) is a multi-function BiCMOS control interface IC which is ideal for driving the gates of FET and pHEMT based MMIC control devices. This unique IC can be used to simplify the control of microwave and millimeterwave transmit/receive modules, military subsystems, and multi-throw/multi-port test and measurement equipment. The HMC677LP5(E) accepts serial or parallel data, and can drive up to 6 complementary sets of outputs.

The HMC677LP5(E) also provides additional functionality such as a power-up state selection, adjustable output voltage levels, and a latched parallel control mode which allows multiple control devices to share a common data bus. The HMC677LP5(E) is ideal for controlling digital phase shifters, digital attenuators, digital variable gain amplifiers, and switching matrices embedded in complex microwave and millimeterwave assemblies.

Electrical Specifications, $T_A = +25^\circ\text{C}$, $V_{dd1} = V_{dd2} = +5\text{V}$, $V_{ee} = -5\text{V}$, $V_{oph} = 0\text{V}$

| Parameter | Min | Typ | Max | Units |
|--|-----------------|-----|----------------|---------------|
| Input High Voltage, V_{ih} | 2 | - | - | V |
| Low Voltage, V_{il} | - | - | 0.8 | V |
| Output High Voltage, V_{oh} ($I_{oh} = 1\text{ mA}$, $V_{ee} = -4.5\text{V}$) | $V_{oph} - 0.1$ | - | - | V |
| Output Low Voltage, V_{ol} ($I_{ol} = 2\text{ mA}$, $V_{ee} = -4.5\text{V}$) | - | - | $V_{ee} + 0.1$ | V |
| Maximum Input Leakage Current, I_{in} | - | - | 1 | μA |
| Propagation Delay, t_{plh} | - | - | 80 | nS |
| Maximum Serial Bit Rate | - | - | 10 | Mbps |
| Maximum I/O Update Rate | - | - | 100 | ns |

6-Bit SERIAL/PARALLEL SWITCH DRIVER/CONTROLLER



Serial Control Interface

The HMC677LP5(E) contains a 3-wire SPI compatible digital interface (DATA, CLK, LE). It is activated when P/S is kept high. The 6-bit serial word must be loaded MSB first. The positive-edge sensitive CLK and LE requires clean transitions. Standard logic families work well. When LE is high, 6-bit data in the serial input register is transferred to the outputs. When LE is high CLK is masked to prevent data transition during output loading.

When P/S is low, 3-wire SPI interface inputs (DATA, CLK, LE) are disabled and the serial input register is loaded asynchronously with parallel digital inputs (I0-I5). When LE is high, 6-bit parallel data is transferred.

For all modes of operations, the outputs will stay constant while LE is kept low.

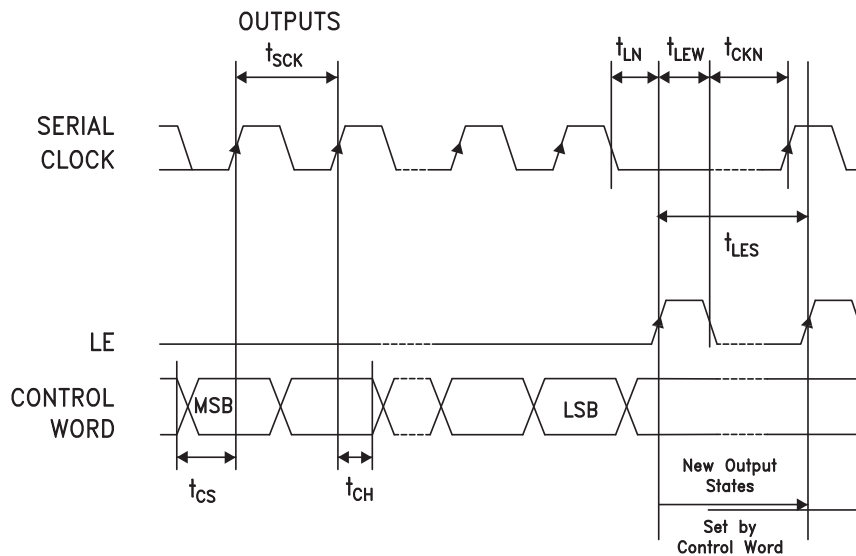

| Parameter | Typ. |
|---|--------|
| Min. serial period, t_{SCK} | 100 ns |
| Control set-up time, t_{CS} | 20 ns |
| Control hold-time, t_{CH} | 20 ns |
| LE setup-time, t_{LN} | 10 ns |
| Min. LE pulse width, t_{LEW} | 10 ns |
| Min LE pulse spacing, t_{LES} | 630 ns |
| Serial clock hold-time from LE, t_{CKN} | 10 ns |
| Hold Time, t_{PH} | 0 ns |
| Latch Enable Minimum Width, t_{LEN} | 10 ns |
| Setup Time, t_{PS} | 2 ns |

Timing Diagram (Latched Parallel Mode)

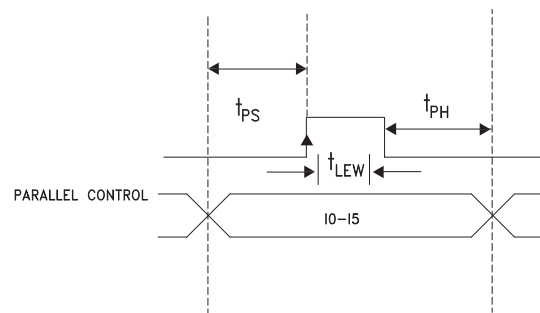

Parallel Mode (Direct Parallel Mode & Latched Parallel Mode)

Note: The parallel mode is enabled when P/S is set to low.

Direct Parallel Mode - Outputs are changed by the Control Voltage Inputs directly. The LE (Latch Enable) must be at a logic high to control in this manner.

Latched Parallel Mode - Outputs are selected using the Control Voltage Inputs and set while the LE is in the Low state. This will not change state while LE is Low. Once all Control Voltage Inputs are at the desired states the LE is pulsed. See timing diagram above for reference.

Information furnished by Analog Devices is believed to be accurate and reliable. However, no responsibility is assumed by Analog Devices for its use, nor for any infringements of patents or other rights of third parties that may result from its use. Specifications subject to change without notice. No license is granted by implication or otherwise under any patent or patent rights of Analog Devices. Trademarks and registered trademarks are the property of their respective owners.

For price, delivery, and to place orders: Analog Devices, Inc., One Technology Way, P.O. Box 9106, Norwood, MA 02062-9106 Phone: 781-329-4700 • Order online at www.analog.com Application Support: Phone: 1-800-ANALOG-D

**6-Bit SERIAL/PARALLEL SWITCH
DRIVER/CONTROLLER**
Operating Ranges

| Function | Parameter | Min. | Typ. | Max | Units |
|------------|-----------------------------------|------|------|------|-------|
| Vdd | Positive DC Supply Voltage | 4.5 | 5.0 | 5.5 | V |
| Vee | Negative DC Supply Voltage | -5.5 | -5.0 | -4.5 | V |
| Voph [1] | DC Output Supply | 0 | - | 2.2 | V |
| Voph - Vee | Negative Supply Voltage Range | 4.5 | - | 7.7 | V |
| Vdd - Vee | Positive to Negative Supply Range | 9 | 10 | 11 | V |
| Ta | Operating Ambient Temperature | -40 | 25 | 85 | C |
| Ioh [2] | DC Output Current - High | 1 | - | - | mA |
| Iol [2] | DC Output Current - Low | 2 | - | - | mA |

[1] Voph can be used from 0V to 2.2V. Higher voltages can be used to increase low frequency performance of GaAs switches.

[2] Ioh and Iol are measured at 0.1V variation from Voph and Vee.

DC Characteristics

| Function | Parameter | Conditions | | Min. | Typ. | Max | Units |
|----------|---|--------------------|------------------|------------|------|-----------|-------|
| Vih | Input High Voltage | High Input Voltage | | 2.0 | - | - | V |
| Vil | Input Low Voltage | Low Input Voltage | | - | - | 0.8 | V |
| Voh | Output High Voltage | Ioh = 1 mA | Vee = -4.5V | Voph - 0.1 | - | - | V |
| Vol | Output Low Voltage | Iol = 2 mA | Vee = -4.5V | - | - | Vee + 0.1 | V |
| Iin | Input Leakage Current | Vin = Vdd or GND | Vdd = Max | - | - | 1 | μA |
| Idd | Quiescent Supply Current | Vdd = Max | Vin = Vdd or GND | - | - | 1.5 | mA |
| ^ Idd | Additional Supply Current Per TTL Input Pin | Vdd = Max | Vin = 2V | - | - | 50 | μA |

Worst Case AC Characteristics at Voph = 2.2V (Vdd = 4.5V, Vee = -4.5V)

| Function | Parameter | -40 °C | +25 °C | +85 °C | Units |
|---------------------|--------------------------------------|--------|--------|--------|-------|
| Tplh | Rising Propagation Delay | 30 | 30 | 30 | ns |
| Tphl | Falling Propagation Delay | 30 | 30 | 30 | ns |
| Ttth | Output Rising Transition Time | 30 | 40 | 40 | ns |
| Tthl | Output Falling Transition Time | 15 | 20 | 20 | ns |
| Tskew | Delay Skew | 50 | 50 | 50 | nS |
| Cpdd ^[1] | Power Dissipation Capacitance of Vdd | 100 | 100 | 100 | pF |
| Cpde ^[1] | Power Dissipation Capacitance of Vee | 400 | 400 | 400 | pF |

Worst Case AC Characteristics at Voph = 0V (Vdd = 4.5V, Vee = -4.5V)

| Function | Parameter | -40 °C | +25 °C | +85 °C | Units |
|---------------------|--------------------------------------|--------|--------|--------|-------|
| Tplh | Rising Propagation Delay | 80 | 80 | 80 | ns |
| Tphl | Falling Propagation Delay | 80 | 80 | 80 | ns |
| Ttth | Output Rising Transition Time | 100 | 100 | 100 | ns |
| Tthl | Output Falling Transition Time | 50 | 50 | 50 | ns |
| Tskew | Delay Skew | 50 | 50 | 50 | nS |
| Cpdd ^[1] | Power Dissipation Capacitance of Vdd | 100 | 100 | 100 | pF |
| Cpde ^[1] | Power Dissipation Capacitance of Vee | 400 | 400 | 400 | pF |

¹ Total Power Dissipation is calculated by the following formula: PD = Vdd² f Cpdd + (Voph - Vee)² f Cpde, where f = frequency in Hz



6-Bit SERIAL/PARALLEL SWITCH DRIVER/CONTROLLER

Power-Up States

If LE is set to logic LOW at power-up, the logic state of PUP1 and PUP2 determines the power-up state of the part per PUP truth table. If the LE is set to logic HIGH at power-up, the logic state of I5-I0 determines the power-up state of the part per truth table. The attenuator latches in the desired power-up state approximately 200 ms after power-up.

Control Voltage Table

| State | Vdd = +3V | Vdd = +5V |
|-------|------------------------|------------------------|
| Low | 0 to 0.5V @ <1 μ A | 0 to 0.8V @ <1 μ A |
| High | 2 to 3V @ <1 μ A | 2 to 5V @ <1 μ A |

Power-On Sequence

The required power-up sequence is: GND, Vdd, Vee, Voph, Digital Inputs (I₀ - I₅). The relative application of input signal order of the digital inputs are not important. Deviations from this sequence may inadvertently forward bias ESD protection structures and damage them. For added protection you may install 2 kOhm resistors in series with each digital input signal line, however these resistors will increase the RC time constant.

Truth Table

| Input | Outputs | |
|----------------|----------------|------------------|
| I _x | B _x | B _x B |
| Low | Vee | Voph |
| High | Voph | Vee |

PUP Truth Table

| LE | PUP2 | PUP1 | Output States | | | | | |
|----|------|------|----------------------------------|----|----|----|----|----|
| | | | B5 | B4 | B3 | B2 | B1 | B0 |
| 0 | 0 | 0 | 0 | 0 | 0 | 0 | 0 | 0 |
| 0 | 0 | 1 | 0 | 1 | 0 | 0 | 0 | 0 |
| 0 | 1 | 0 | 1 | 0 | 0 | 0 | 0 | 0 |
| 0 | 1 | 1 | 1 | 1 | 1 | 1 | 1 | 1 |
| 1 | X | X | Set by the inputs I _x | | | | | |

For the Inputs (LE, PUP1, PUP2), Logic "0" = 0V and Logic "1" = Vdd

For the outputs, Logic "0" is B_x = Vee, B_xB = Voph, and Logic "1" is B_x = Voph, B_xB = Vee

**6-Bit SERIAL/PARALLEL SWITCH
DRIVER/CONTROLLER**
Absolute Maximum Ratings

| | |
|---|-------------------|
| Digital Inputs (I0-I5, Shift Clock, Latch Enable, P/S, PUP and Data Inputs) | -0.5 to Vdd +0.5V |
| Bias Voltage (Vdd) | 5.6 V |
| Bias Voltage (Vee) | -5.6 V |
| Bias Voltage (Voph) | 2.3 V |
| Channel Temperature | 125 °C |
| Continuous P _{diss} (T = 85 °C) (derate 8.2 mW/°C above 85 °C) [1] | 325 mW |
| Thermal Resistance (Channel to ground paddle) | 123 °C/W |
| Storage Temperature | -65 to +150 °C |
| Operating Temperature | -40 to +85 °C |

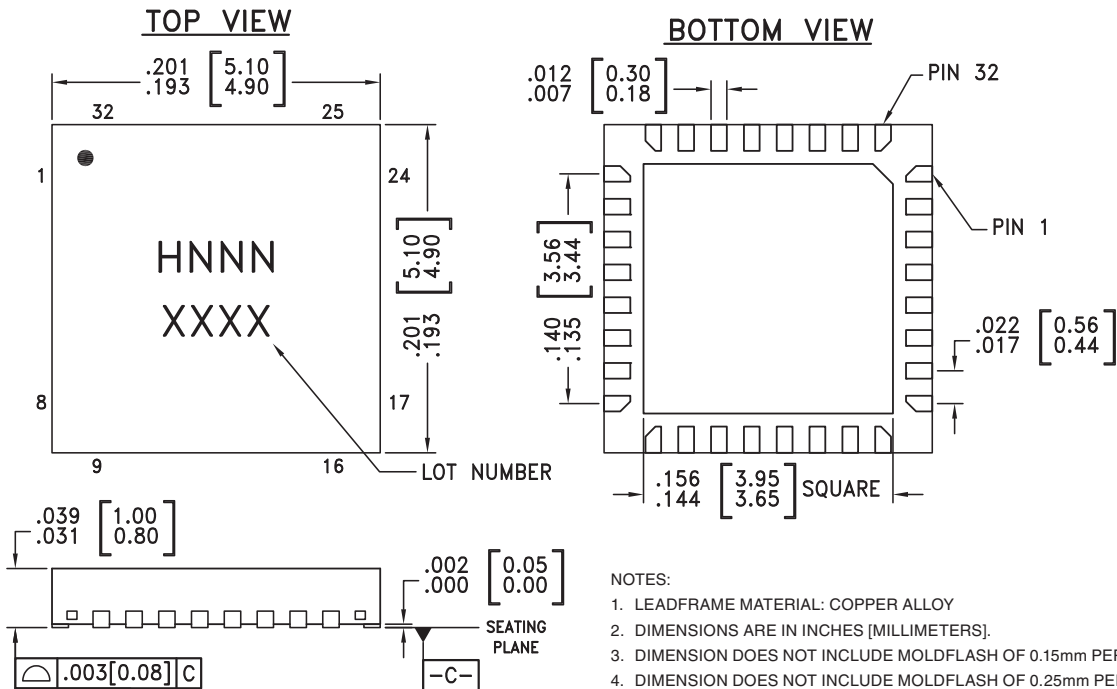
**ELECTROSTATIC SENSITIVE DEVICE
OBSERVE HANDLING PRECAUTIONS**
Outline Drawing

Package Information

| Part Number | Package Body Material | Lead Finish | MSL Rating | Package Marking [3] |
|-------------|--|---------------|------------|---------------------|
| HMC677LP5 | Low Stress Injection Molded Plastic | Sn/Pb Solder | MSL1 [1] | H677 XXXX |
| HMC677LP5E | RoHS-compliant Low Stress Injection Molded Plastic | 100% matte Sn | MSL1 [2] | H677 XXXX |

[1] Max peak reflow temperature of 235 °C

[2] Max peak reflow temperature of 260 °C

[3] 4-Digit lot number XXXX

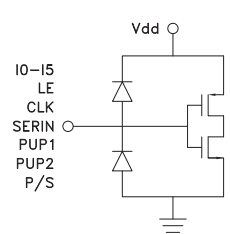
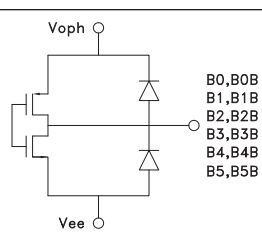
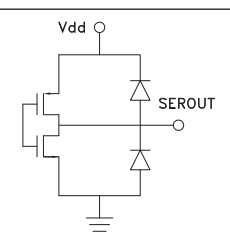

**6-Bit SERIAL/PARALLEL SWITCH
DRIVER/CONTROLLER**
Pin Descriptions

| Pin Number | Function | Description | Interface Schematic |
|------------------------|------------|---|---|
| 1, 29 | Vdd1, Vdd2 | Supply Voltage | |
| 2 - 7 | I0 - I5 | See Truth Table, Control Voltage Table and Timing Diagram |  |
| 9 | P/S | | |
| 10 | CLK | | |
| 11 | SERIN | | |
| 12 | LE | | |
| 31, 32 | PUP2, PUP1 | | |
| 8, 13, 14 | N/C | | |
| 15, 17, 19, 21, 23, 25 | B0 - B5 | Complementary Outputs |  |
| 16, 18, 20, 22, 24, 26 | B0B - B5B | | |
| 27 | Vee | Negative Supply. | |
| 28 | VOPH | User selectable output high voltage 0 to +2.2V | |
| 30 | SEROUT | Serial input data delayed by six clock cycles. |  |

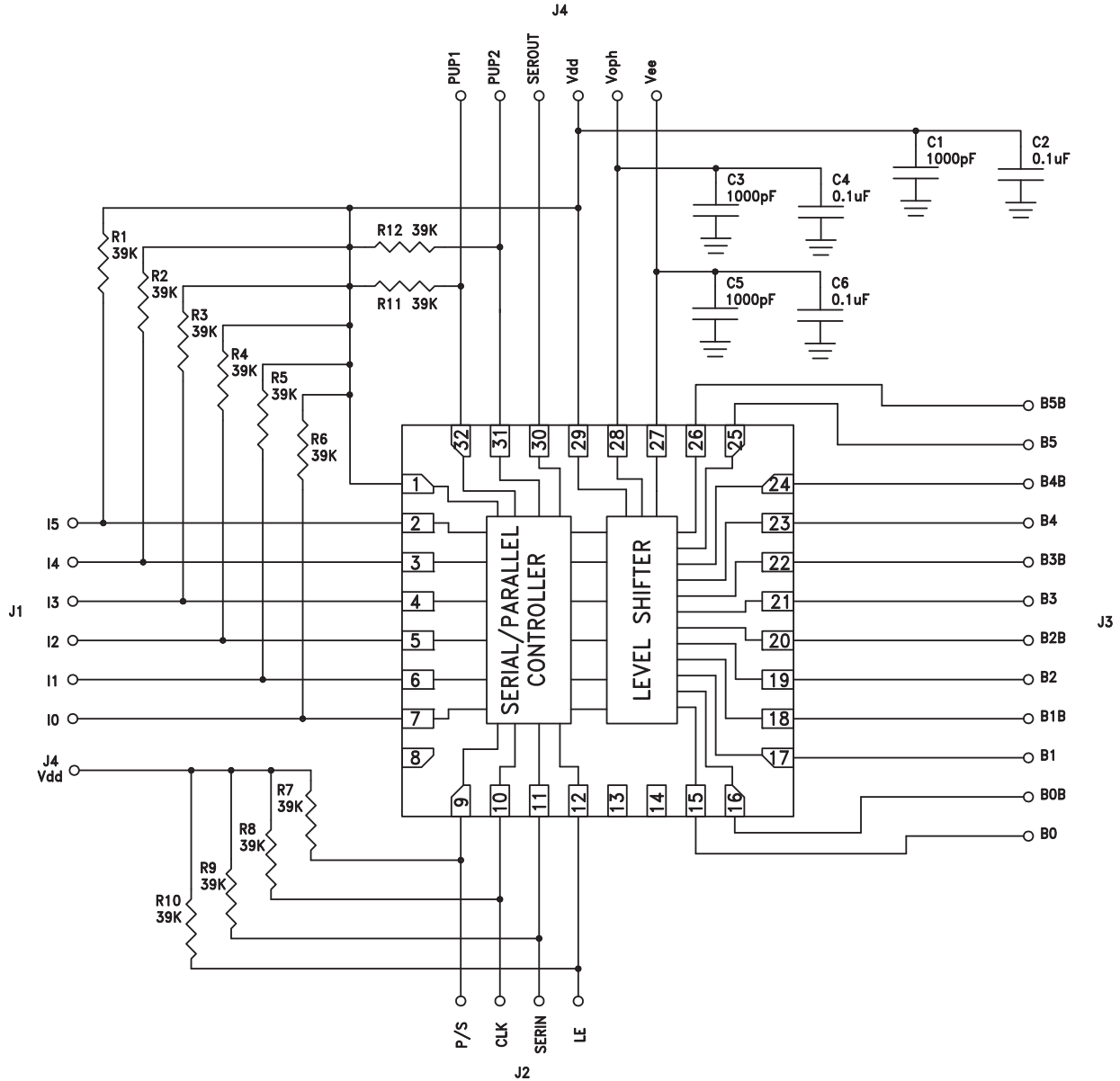

**6-Bit SERIAL/PARALLEL SWITCH
DRIVER/CONTROLLER**

Application & Evaluation PCB Schematic





6-Bit SERIAL/PARALLEL SWITCH DRIVER/CONTROLLER

Evaluation PCB

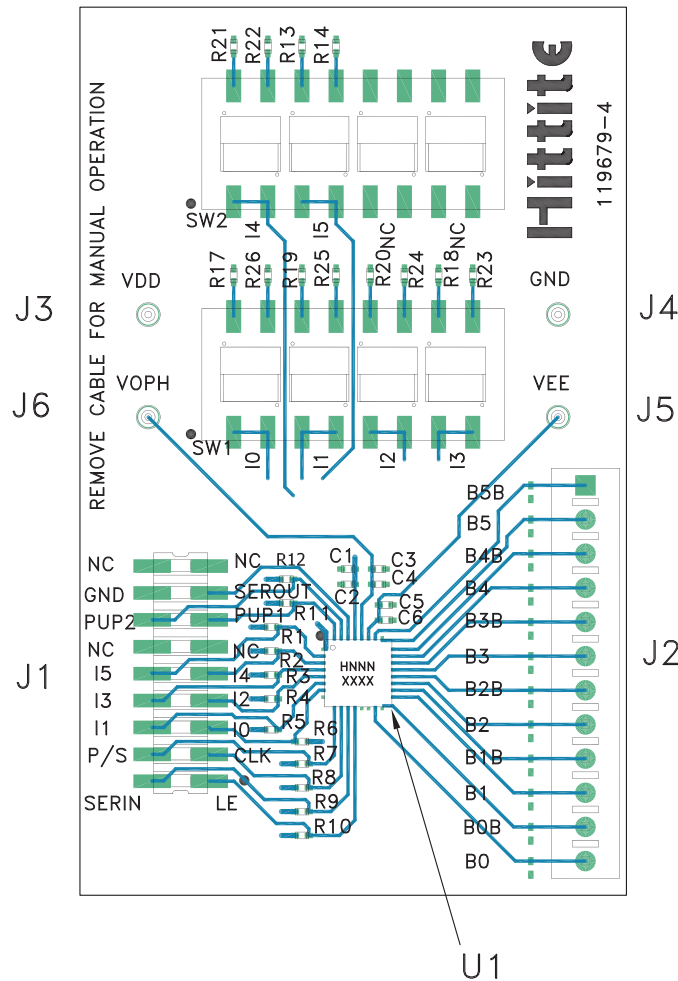

List of Materials for Evaluation PCB 119681 [1][3]

| Item | Description |
|---------------------|--|
| J1 | 18 Pin DC Connector |
| J2 | 12 Pin DC Connector |
| J3 - J6 | DC Pin |
| C1, C3, C5 | 1000 pF Capacitor, 0402 Pkg. |
| C2, C4, C6 | 0.1 μ F Capacitor, 0402 Pkg. |
| R1 - R12 | 39 k Ω Resistor, 0402 Pkg. |
| R13, R14, R17 - R26 | 100 k Ω Resistor, 0402 Pkg. |
| SW1, SW2 | SPDT 4 Position DIP Switch |
| U1 | HMC677LP5(E) 6-Bit Digital Level Shifter |
| PCB [2] | 119679 Evaluation PCB |

The evaluation circuit board shown is available from Hittite upon request.

[1] Reference this number when ordering complete evaluation PCB

[2] Circuit Board Material: FR4

[3] Please refer to part's pin description and functional diagram for pin out assignments on evaluation board.

Looking for pricing, stock, or lifecycle information?

Click below to explore more details on WIN SOURCE:

 [View HMC677LP5E on WIN SOURCE](#)

 [Analog Devices Inc. Information](#)

Optimize Your Supply Chain with WIN SOURCE Solutions

-  Global Sourcing Solution
-  Obsolete Management
-  Cost Control Management
-  Shortage Management
-  Alternative Solution
-  Excess Inventory Management