



**THE DATASHEET OF
VFR3VD31E131T51B**



EMIGUARD
VFR3V Series **Reference Specification**

1. Scope

This reference specification applies to EMIGUARD applicable to automatic insertion, which is used electronic equipment.

2. Part Numbering

$\frac{VF}{\text{Product ID}}$ $\frac{R}{\text{Structure}}$ $\frac{3}{\text{Style}}$ $\frac{V}{\text{Features}}$ $\frac{D3}{\text{Temperature Characteristics}}$ $\frac{1E}{\text{Rated Voltage}}$ $\frac{131}{\text{Capacitance}}$ $\frac{T51}{\text{Lead Type}}$ $\frac{B}{\text{Packaging Code}}$
 [A : Ammo Pack / B : Bulk]

Customer Part Number	Part Number	Packaging Code
	VFR3VD31E131T51B	Bulk type
	VFR3VD31E131U31A	Taping type

3. Rating

Item	Specification
Rated Voltage	25 V(DC)
Capacitance	130 pF ± 20 %
Insulation Resistance	10 MΩ min.
Varistor Voltage	50 V(DC) ± 20 %
DC Resistance	150 Ω ± 35 %
Rated Current	20 mA(DC)
Operating Temperature	- 25 °C to + 85 °C
Storage Temperature	- 25 °C to + 85 °C

4. Standard Testing Condition

< Unless otherwise >

Temperature : Ordinary Temp. 15 °C to 35 °C
 Humidity : Ordinary Humidity 25 %(RH) to 85 %(RH)

< In case of doubt >

Temperature : 20 °C ± 2 °C
 Humidity : 60 %(RH) to 70 %(RH)
 Atmospheric pressure : 86 kPa to 106 kPa

5. Style and Dimensions

Meet Item 11.

6. Marking

The following items shall be marked.

Mark of T1 Terminal : Marked as ●
 Symbol : Marked as AY.

7. Electrical Performance

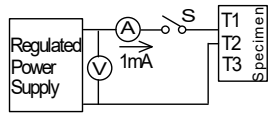
No.	Item	Specification	Test Method												
7.1	Capacitance	Meet Item 3.	Measured between T1 and T2 terminal. Frequency : 1 ± 0.1 kHz Voltage : 1 ± 0.2 V(rms)												
7.2	Insulation Resistance (I.R.)		Measured between T1 and T2 terminal. Time : 30 ± 5 seconds												
7.3	Varistor Voltage		Measuring DC Current : 1 mA 												
7.4	DC Resistance		Measured between T1 and T3 terminal. Measuring Current : less than rated current.												
7.5	Temperature Characteristics (Capacitance)		within ± $\begin{matrix} 20 \\ 30 \end{matrix}$ %												
			Capacitance shall be measured at each step specified in Table 1 after reaching thermal equilibrium. The capacitance change against the capacitance at step 3 shall be calculated. <u>Table 1</u>												
			<table border="1" style="width: 100%; border-collapse: collapse;"> <thead> <tr> <th style="width: 10%;">Step</th> <th style="width: 10%;">1</th> <th style="width: 10%;">2</th> <th style="width: 10%;">3</th> <th style="width: 10%;">4</th> <th style="width: 10%;">5</th> </tr> </thead> <tbody> <tr> <td>Temperature (°C)</td> <td>+20±2</td> <td>-25±$\begin{matrix} 0 \\ 3 \end{matrix}$</td> <td>+20±2</td> <td>+85±$\begin{matrix} 3 \\ 0 \end{matrix}$</td> <td>+20±2</td> </tr> </tbody> </table>	Step	1	2	3	4	5	Temperature (°C)	+20±2	-25± $\begin{matrix} 0 \\ 3 \end{matrix}$	+20±2	+85± $\begin{matrix} 3 \\ 0 \end{matrix}$	+20±2
Step	1	2	3	4	5										
Temperature (°C)	+20±2	-25± $\begin{matrix} 0 \\ 3 \end{matrix}$	+20±2	+85± $\begin{matrix} 3 \\ 0 \end{matrix}$	+20±2										

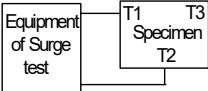
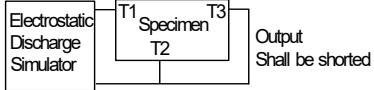
No.	Item	Specification	Test Method				
7.6	Temperature Characteristics (DC Resistance)	within $\pm 30\%$	DC Resistance shall be measured at each step specified in Table 1 after reaching thermal equilibrium. The DC Resistance change against the DC Resistance at step 3 shall be calculated.				
7.7	Withstanding Surge Current	Meet Table 2. <table border="1"> <thead> <tr> <th>Appearance</th> <th>No damage</th> </tr> </thead> <tbody> <tr> <td>Varistor Voltage Change</td> <td>within $\pm 10\%$</td> </tr> </tbody> </table>	Appearance	No damage	Varistor Voltage Change	within $\pm 10\%$	Waveform : 80/20 μ s (rectangular pulse) Peak current : 30A The Number of Times : 2 times (5 minutes interval) Then measured after exposure in the room condition for 1 to 2 hours. Measuring varistor voltage : as same as the above surge current. 
Appearance	No damage						
Varistor Voltage Change	within $\pm 10\%$						
7.8	Pulse Life		Waveform : 150pF,330 Ω ESD contact discharge. (IEC1000-4-2) Peak Voltage : 15 kV The Number of Times : 100 times (10 times/s) Then measured after exposure in the room condition for 1 to 2 hours. Measuring varistor voltage : as same as the above surge current. 				

8. Mechanical Performance

No.	Item	Specification	Test Method								
8.1	Appearance and Dimensions	Meet Item 5.	Visual inspection and measured with slide calipers.								
8.2	Marking	Marking shall be legible	It is inspection Visually.								
8.3	Solderability	Along the circumference of terminal shall be covered with new solder at least 90%.	Flux : Ethanol solution of rosin, 25(wt)% Pre-heat : 150 \pm 10 $^{\circ}$ C, 60 ~ 90 seconds Solder : Sn-3.0Ag-0.5Cu Solder Temperature : 245 \pm 5 $^{\circ}$ C Immersion Time : 2 \pm 0.5 seconds Immersion Depth : 1.5 to 2.0 mm from the bottom of the body								
8.4	Resistance to Soldering Heat	Meet Table 3. <table border="1"> <thead> <tr> <th>Appearance</th> <th>No damage</th> </tr> </thead> <tbody> <tr> <td>Cap.Change</td> <td>within $\pm 20\%$</td> </tr> <tr> <td>Varistor Voltage Change</td> <td>within $\pm 10\%$</td> </tr> <tr> <td>I.R.</td> <td>10 MΩ min.</td> </tr> </tbody> </table>	Appearance	No damage	Cap.Change	within $\pm 20\%$	Varistor Voltage Change	within $\pm 10\%$	I.R.	10 M Ω min.	Flux : Ethanol solution of rosin, 25(wt)% Pre-heat : 150 \pm 10 $^{\circ}$ C, 60 ~ 90 seconds Solder : Sn-3.0Ag-0.5Cu Solder Temperature : 270 \pm 5 $^{\circ}$ C Immersion Time : 3 \pm 0.5 seconds Immersion Depth : 1.5 to 2.0 mm from the bottom of the body Then measured after exposure in the room condition for 1 to 12 hours.
Appearance	No damage										
Cap.Change	within $\pm 20\%$										
Varistor Voltage Change	within $\pm 10\%$										
I.R.	10 M Ω min.										
8.5	Terminal Pull Test	Products shall be damaged.	It shall be fixed and the load shall be applied to three terminals gradually in the direction of the terminals. Applying Force : 10N Keeping Time : 10 seconds * Products should be used by being mounted through P.C.B. hole.								
8.6	Terminal Bent Test		It shall be fixed and the load of 5N shall be suspended Then the body shall be bent through 90 $^{\circ}$ and returned to its normal position. And the body shall be ben through 90 $^{\circ}$ in the opposite direction, and returned to its normal position. * Products should be used by being mounted through P.C.B. hole.								

9. Environment Performance

No.	Item	Specification	Test Method										
9.1	Temperature Cycling	Meet Table 3.	1 Cycle 1 step : $-25 \pm \frac{3}{0} \text{ } ^\circ\text{C}$ / 30 minutes 2 step : Room Temperature / 5 min within. 3 step : $+85 \pm \frac{3}{0} \text{ } ^\circ\text{C}$ / 30 minutes 4 step : Room Temperature / 5 min within. Total of 10 cycles Then measured after exposure in the room condition for 1 to 12 hours.										
9.2	Humidity												
9.3	Humidity Load	Meet Table 4. <table border="1" style="margin-left: 20px; border-collapse: collapse;"> <thead> <tr> <th colspan="2">Table 4</th> </tr> </thead> <tbody> <tr> <td>Appearance</td> <td>No damage</td> </tr> <tr> <td>Cap.Change</td> <td>within $\pm 20\%$</td> </tr> <tr> <td>Varistor Voltage Change</td> <td>within $\pm 10\%$</td> </tr> <tr> <td>I.R.</td> <td>1 MΩ min.</td> </tr> </tbody> </table>	Table 4		Appearance	No damage	Cap.Change	within $\pm 20\%$	Varistor Voltage Change	within $\pm 10\%$	I.R.	1 M Ω min.	Temperature : $40 \pm 2 \text{ } ^\circ\text{C}$ Humidity : 90 to 95 %(RH) Time : $500 \pm \frac{2}{0} \text{ } \text{hours}$ Then measured after exposure in the room condition for 4 to 24 hours.
Table 4													
Appearance	No damage												
Cap.Change	within $\pm 20\%$												
Varistor Voltage Change	within $\pm 10\%$												
I.R.	1 M Ω min.												
9.4	Heat Life		Temperature : $85 \pm 3 \text{ } ^\circ\text{C}$ Test Voltage : 35 V(DC) Time : $500 \pm \frac{2}{0} \text{ } \text{hours}$ Then measured after exposure in the room condition for 4 to 24 hours. The voltage shall be applied between T1 and T2 terminal. Measuring direction of varistor voltage : as same as that of applied voltage.										

10. Insertion Loss (Typ.)

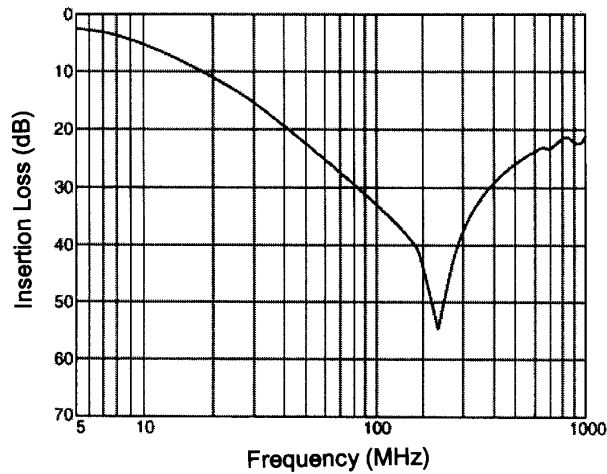

Insertion Loss measuring circuit

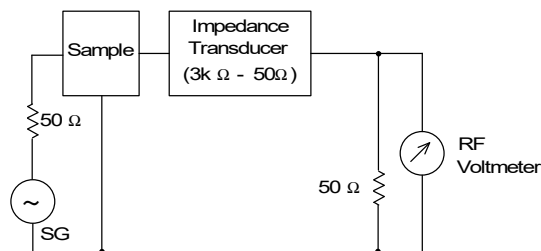

11. Style and Dimensions

11.1. Bulk (VFR3VD31E131T51B Type)

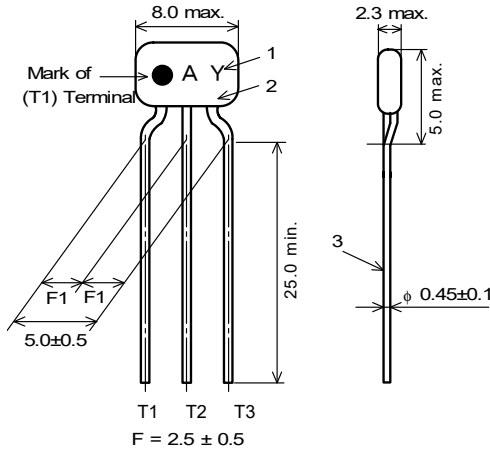

Mounting Hole

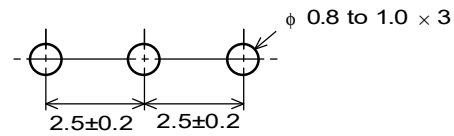

<List of MATERIAL>

No.	ITEM	MATERIAL
1	Over Coating	Epoxy Resin
2	Armor	Phenol Resin
3	Lead Wire	Annealed Copper Wire Solder Coating

■ Unit Mass (Typical value)
0.23g

11.2. Taping (VFR3VD31E131U31A Type)

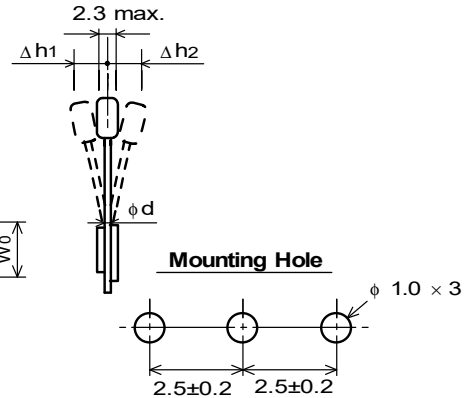
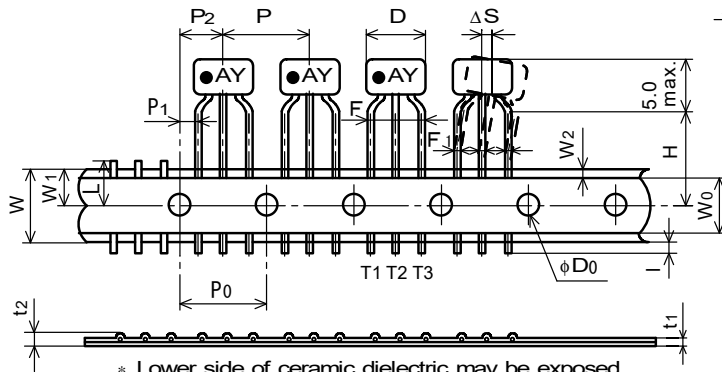

* Lower side of ceramic dielectric may be exposed.

(in mm)

Code	Description	Dimensions	Remarks
P	Pitch of Component	12.7	Product Inclination ΔS Determines Crossing
P ₀	Pitch of Sprocket Hole	12.7 ± 0.2	
P ₁	Length from Hole Center to Lead	3.85 ± 0.7	
P ₂	Length from Hole Center to Component Center	6.35 ± 1.3	Shift In Tape In Direction of Feed
D	Width of Body	8.0 max.	
ΔS	Deviation along tape, Left or Right	0 ± 1.0	
W	Carrier Tape Width	18.0 ± 0.5	
W ₁	Position of Sprocket Hole	9.0 ± ⁰ / _{0.5}	Tape Widthwise Shift
l	Protrusion Length	+ 0.5 to + 1.0	
D ₀	Diameter of Sprocket Hole	φ 4.0 ± 0.1	
d	Lead Diameter	φ 0.45 ± 0.1	
t ₁	Total Tape Thickness	0.7 ± 0.2	Includes Thickness of Bonding Tape
t ₂	Total Thickness, Tape and Lead Wire	1.5 max.	
Δh ₁	Deviation across Tape , front	1.0 max.	
Δh ₂	Deviation across Tape , rear	1.0 max.	
L	Portion to Cut in Case of Defect	11.0 ±	
W ₀	Hold Down Tape Width	12.0 ± 0.5	
W ₂	Hold Down Tape Position	1.5 ± 1.5	
H	Lead length between sprocket hole and forming position	18.5 ± 1.0	
F	Lead Spacing	5.0 ± ^{0.8} / _{0.2}	
F ₁		2.5 ± ^{0.4} / _{0.2}	

12. Taping

12.1. A maximum of 0.3 % of the components quantity per Ammo pack may be missing without consecutive missing components.

12.2. The adhesive power of the tape shall have over 2.94N at the following condition.

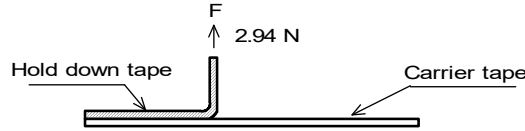

12.3. Splicing method of tape

(1) Carrier tape

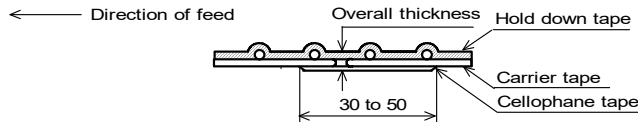

Carrier tape shall be spliced by cellophane tape. Overall thickness shall be less than 1.05 mm. (in mm)

(2) Hold down tape

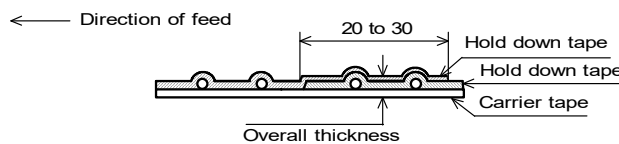

- Hold down tape shall be spliced with overlapping.
- Overall thickness shall be less than 1.05 mm. (in mm)

(3) Both carrier tape and hold down tape

Both tapes shall be cut zigzag and spliced with splicing tape.

13. Packing Quantity and Packing Form

The standard packing is as follows.

(The packing quantity may be changed due to a fraction of order)

Minimum Packing Form and Quantity

Terminal Configuration	A Unit Quantity Bulk : in a plastic bag Taping : in an Ammo pack	* Standard Quantity in a container (corrugated cardboard box)
VFR3VD31E131T51B (Bulk)	250 pcs.	5000 pcs.
VFR3VD31E131U31A (Taping)	2000 pcs.	20000 pcs.

* A quantity in a container is depending on a quantity of an order.

13.1. Bulk

· A plastic bag pack

(1) Products are packed into a plastic bag.

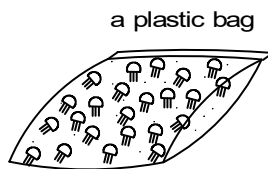

(2) The plastic bags are put into a container (corrugated cardboard box) depending on a quantity of an order.

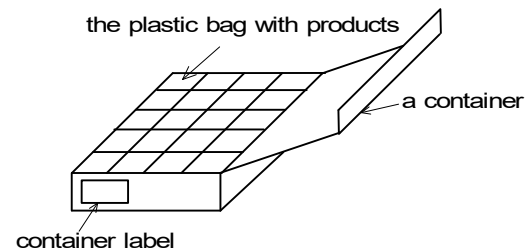

13.2. Taping

· An ammo pack

(1) Folding the tape per 25 pitches, products are packed into an ammo package so that each product of each layer wound zigzag is put on top of one another.

(2) The dimensions of the ammo package are as follows.

(3) The ammo packages are put into a container (corrugated cardboard box) depending on a quantity of an order.

(4) Not less than 3 consecutive of component shall be missing on both edge of tape.

16.2. Products should be used at rated voltage or less and rated current or less.

16.3. Products should not be applied for the absorption of surge which have large energy (ex. induced lightning surges, switching surges) because it is designed for the absorption of electrostatic surges.

16.4. Electrostatic test

Electrostatic test should be done on the following conditions.

$$n \cdot [C / R \cdot V^2]^2 < 8.0 \times 10^5$$

n : Times applies

V : Testing Voltage (kV)

C : Charging Capacitance (pF)

R : Charging Resistance (Ω)

16.5. Soldering

(1) Flux, Solder

• Rosin-based flux should be used.

• Do not use strong acidic flux with halide content exceeding 0.2(wt)% (chlorine conversion value.)

• Use Sn-3.0Ag-0.5Cu solder.

(2) Standard flow soldering profile.

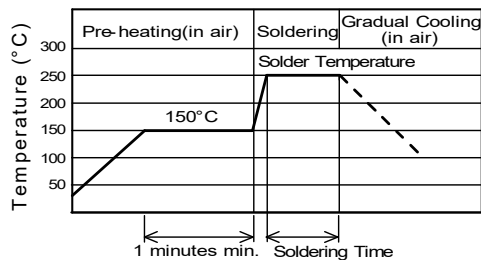

Solder Temperature	Soldering Time
250 ~ 260 °C	4 ~ 6 s

(3) Resistance to soldering iron goes in the following condition that tip temperature is 350 °C max. and soldering time is 5 s max.

(4) Products and the leads should not be subjected to any mechanical stress during soldering process. (and also while subjected to the equivalent high temperature.)

16.6. Cleaning

Avoid cleaning products.

16.7. Operating Environment

(1) Do not use products in corrosive gased such as chlorine gas, acid or sulfide gas.

(2) Do not use products in the environment where water, oil or organic solvents may adhere to products.

(3) Do not adhere any resin to products, coat nor mold products with any resin (including adhesive) to prevent mechanical and chemical stress on products.

16.8. Storage condition

(1) Storage period

Products which inspected in MURATA over 12 months ago should be examined and used, which can be confirmed with inspection No. marked on the container.

(2) Storage environment condition

• Products should be storage in the warehouse on the following conditions.

Temperature : - 10 °C to + 40 °C

Humidity : 15% to 85% relative humidity No rapid change on temperature and humidity

• Don't keep products in corrosive gases such as sulfur, chlorine gas or acid, or it may cause oxidization of electrode, resulting in poor solderability.

• Products should be stored on the palette for the prevention of the influence from humidity, dust and so on.

• Products s should be stored in the warehouse without heat shock, vibration, direct sunlight and so on.

• Products should be stored under the airtight packaged condition.

(3) Delivery

Care should be taken when transporting or handling product to avoid excessive vibration or mechanical shock.

17. ⚠ Notes



(1) Please make sure that your product has been evaluated in view of your specifications with our product being mounted to your product.

(2) You are requested not to use our product deviating from the reference specifications.

(3) The contents of this reference specification are subject to change without advance notice. Please approve our product specifications or transact the approval sheet for product specifications before ordering.

Looking for pricing, stock, or lifecycle information?

Click below to explore more details on WIN SOURCE:

-  [View VFR3VD31E131T51B on WIN SOURCE](#)
-  [Murata Electronics North America Information](#)

Optimize Your Supply Chain with WIN SOURCE Solutions

-  Global Sourcing Solution
-  Obsolete Management
-  Cost Control Management
-  Shortage Management
-  Alternative Solution
-  Excess Inventory Management