



THE DATASHEET OF
158563430





White LEDs

2014

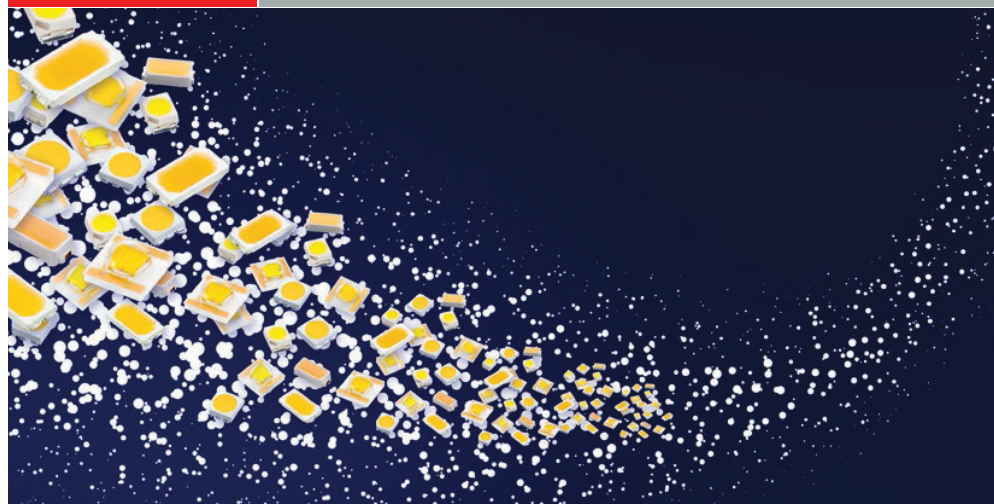

Ceramic LED
PLCC LED

General information



Spectrum distribution of white LEDs

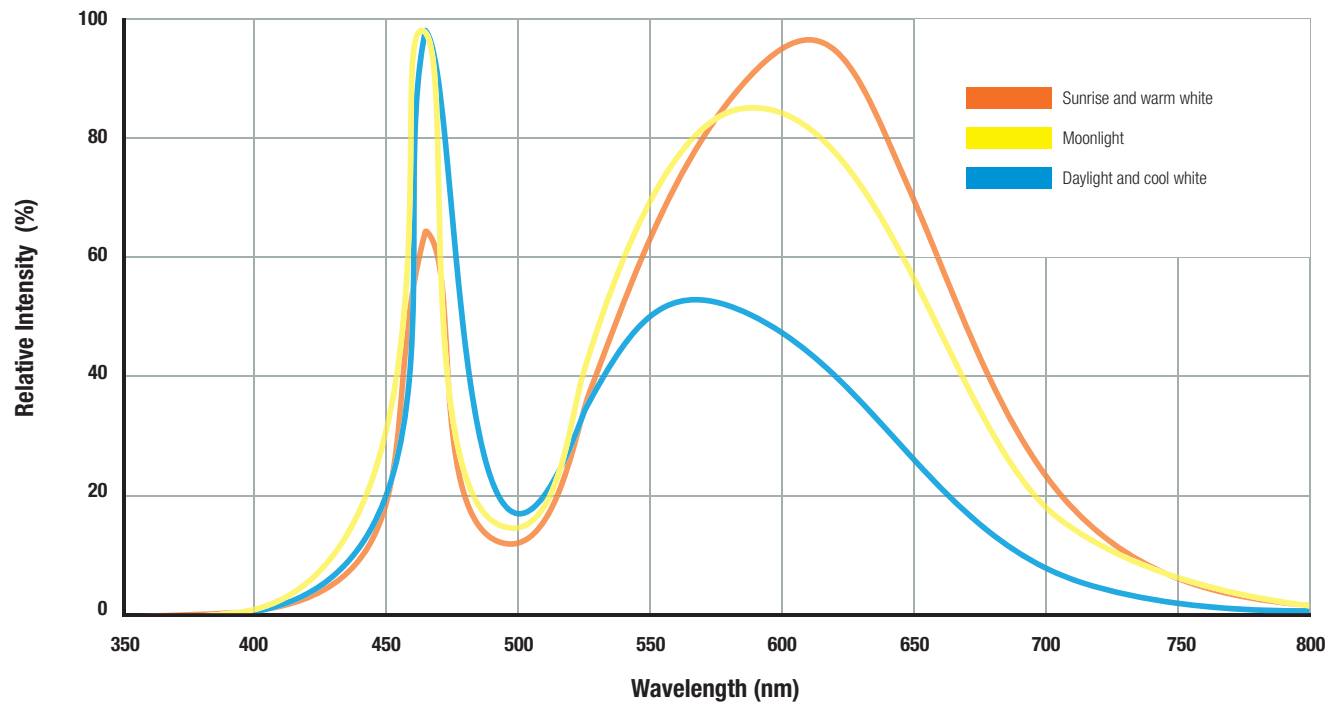

Temperature range:

- Operating temperature: -40 °C to +85 °C
- Storage temperature (on tape & reel): -40 °C to +85 °C 60 % RH max.



The standard deliveries include values in the range and limitation as defined in the Electrical & Optical Properties specified in the datasheet. On each reel, only one bin is sorted and taped. The bin is defined on intensity, chromaticity coordinate or wavelength and forward voltage. In order to ensure highest availability, the reel binning of standard deliveries can vary. A single bin cannot be ordered. Please contact us in advance, if you need a particular bin sorting before placing your order to clarify the lead time, MOQ and pricing.

Soldering Specifications

H1: Classification Reflow Profile for SMT components:

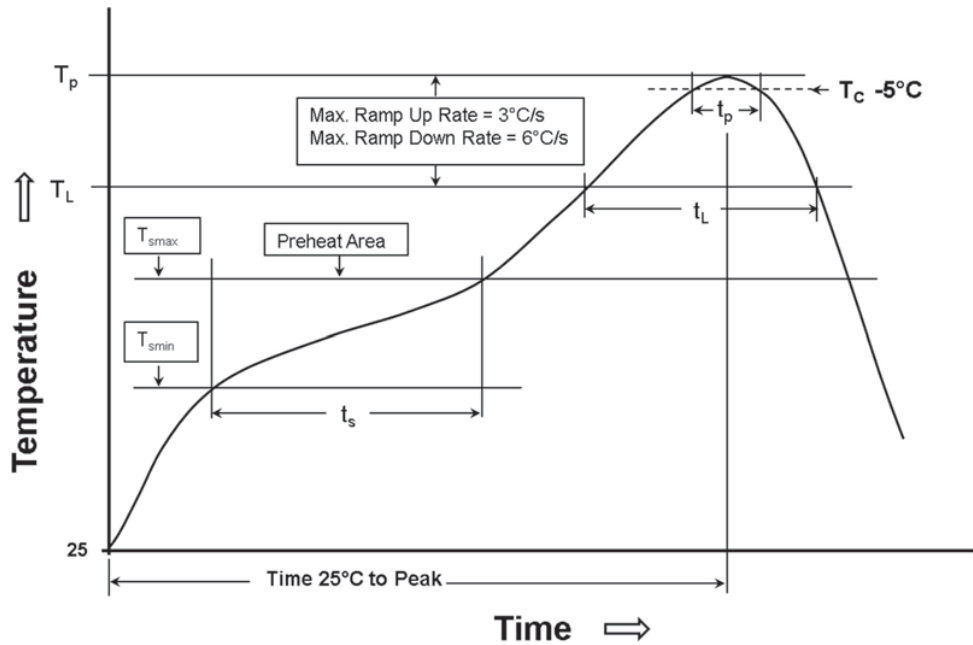

H2: Classification Reflow Profile:

Profile Feature	Pb-Free Assembly
Preheat	
■ Temperature Min (T_{smin})	150 °C
■ Temperature Max (T_{smax})	200 °C
■ Time (t_s) from (T_{smin} to T_{smax})	120 seconds max.
Ramp-up rate (T_L to T_p)	3 °C/second max.
Liquidous temperature (T_L)	217 °C
Time (t_L) maintained above T_L	60 seconds max.
Peak package body temperature (T_p)	250 °C max.
Time within 5 °C of actual peak temperature (t_p)	10 seconds max.
Ramp-down rate (T_p to T_L)	6 °C/second max.
Time 25 °C to peak temperature	220 seconds max.
Applied cycles	2 cycles max.

Photo-Biological Hazard

according to EN 62471:2008



EN 62471:2008 (CIE S009) "Photo-Biological safety of lamps and lamp systems" reflects the state of the incoherent light source nowadays and is recommended for immediate use. The standard sets out requirements in terms of limiting values, methods of measurement and classification criteria. The classification of luminaires is based on hazard values reported at a distance which produces 500 lux illuminance, but not at a distance less than 200 mm.

For the photo-biological parameters (e.g. risk of photochemical retinal damage) of each risk group, wavelength-weighted emission limits have been defined as a basis for classification. The individual risk groups are defined as follows:

- Exempt group: Luminaires present no photo-biological hazard.
- Risk group 1 (Low-Risk): Luminaires present no hazard due to normal behavioural limitations on exposure.
- Risk group 2 (Moderate-Risk): Luminaires present no hazard due to the aversion response to very bright light sources or due to thermal discomfort.
- Risk group 3 (High-Risk): Luminaires present a hazard even for momentary or brief exposure. Use in general lighting service is not allowed.

LED light sources for general lighting are not normally IR or UV radiators, so the table as below confined to hazards that may actually be presented – does not include infrared and ultraviolet hazards.

Results of the risk group classification for LEDs of Würth Elektronik eiPal:

Product Family	Size	Article number	Emitting color	Risk group
WL-SWTC	3535	158 353 027	Sunrise	1
		158 353 060	Cool white	1
WL-SWTP	5630	158 563 427	Sunrise	1
		158 563 460	Cool white	1
WL-SWTP	3022	158 302 227	Sunrise	Exempt group
		158 302 260	Cool white	1
WL-SWTP	3014	158 301 227	Sunrise	1
		158 301 260	Cool white	1

If you need any further information, please contact our sales staff.

WL-SWTC

SMD White Top view Ceramic LED

Size 3535, waterclear dome lens



Characteristics

- Fast switching
- No IR radiation
- High brightness
- Minimal side emission
- Waterclear silicone lens
- Top view
- Flexible coupling with secondary optic
- Various color temperatures
- Compact footprint
- Thermal resistance junction to solder point: 8 °C/W
- LED junction temperature: 150 °C

Applications

- Indoor lighting: Spot light, Down light
- Outdoor lighting: Street light, Security light, Tunnel light, Parking lots light
- Industrial lighting: High-bay light, Low-bay light
- Consumer lighting: Torch light
- Agricultural equipment lighting
- Signal and symbol luminaries

Electrical & Optical Characteristics @ 350 mA (typ.)

Order Code	Emitting color	CCT (K)	CRI	Φ_v (lm)	V_f (V)	Chip Technology	$2\theta_{50\%}$ (°)	Packaging (pcs.)
158353027	Sunrise	2700	80	87	3.2	GaN	120	Tape & reel 1000
158353030	Warm White	3000	80	87				
158353040	Moonlight	4000	75	103				
158353050	Daylight	5000	70	114				
158353060	Cool White	6000	70	114				

CCT = Correlated Color Temperature
 CRI = Color Rendering Index
 Φ_v = Luminous Flux
 V_f = Forward Voltage
 $2\theta_{50\%}$ = Viewing Angle

Dimensions (in mm)

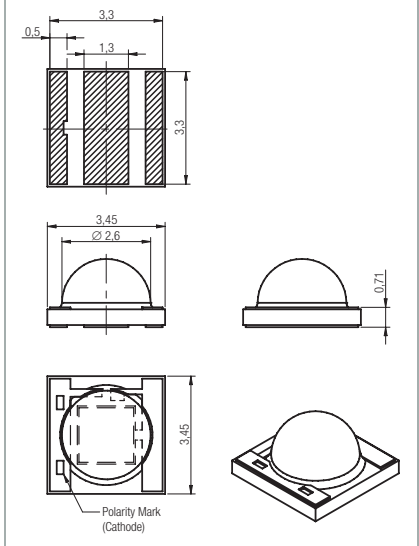

Viewing angle

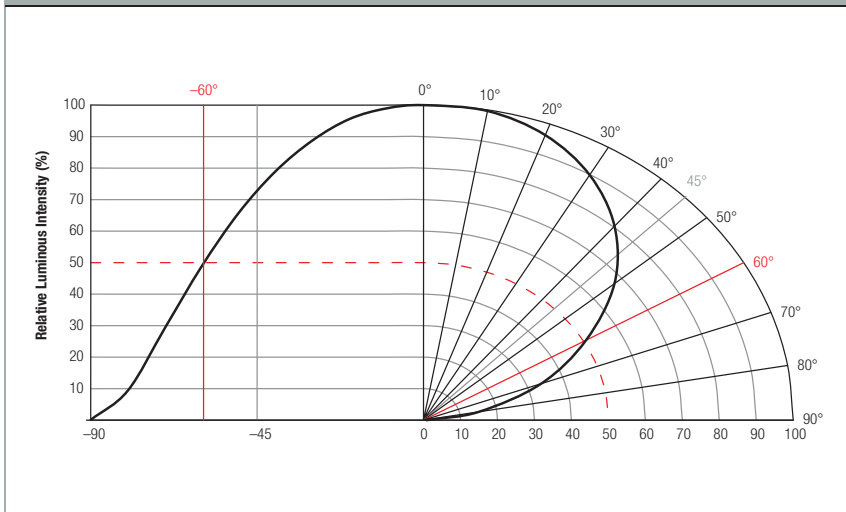

Recommended land pattern (in mm)

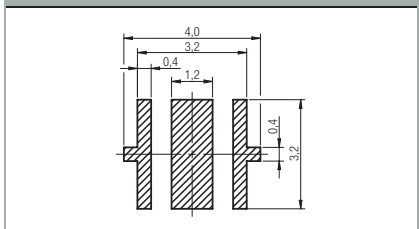

WL-SWTC

SMD White Top view Ceramic LED

Size 3535, waterclear dome lens



Forward current vs. Forward voltage

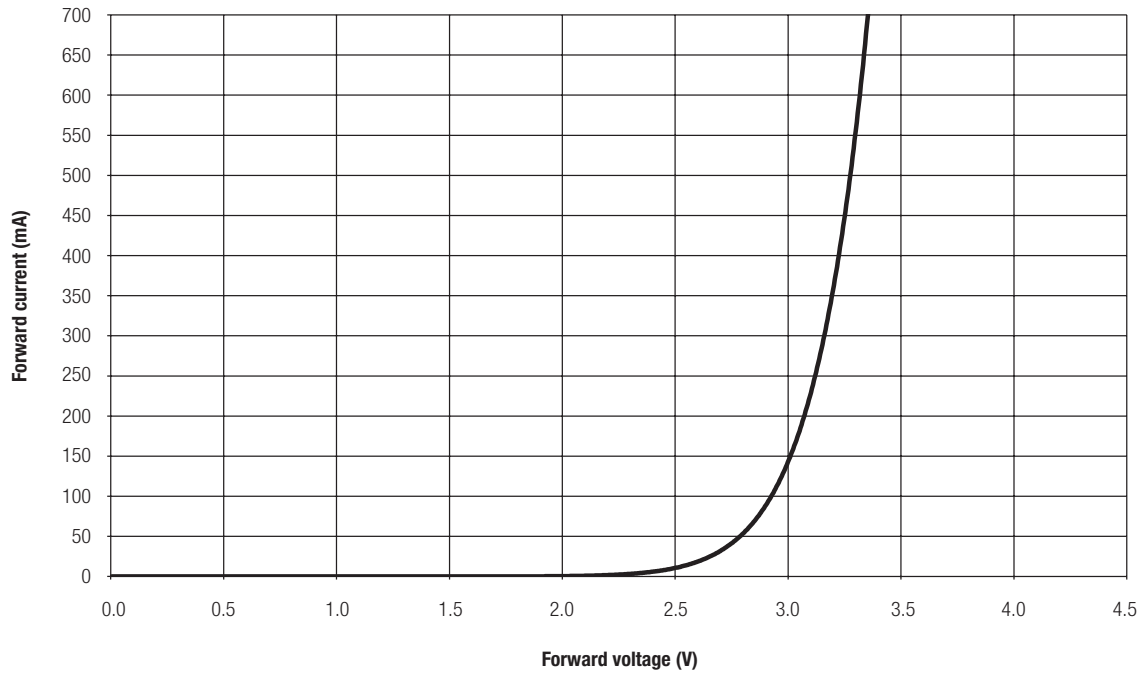

Luminous flux vs. Forward current

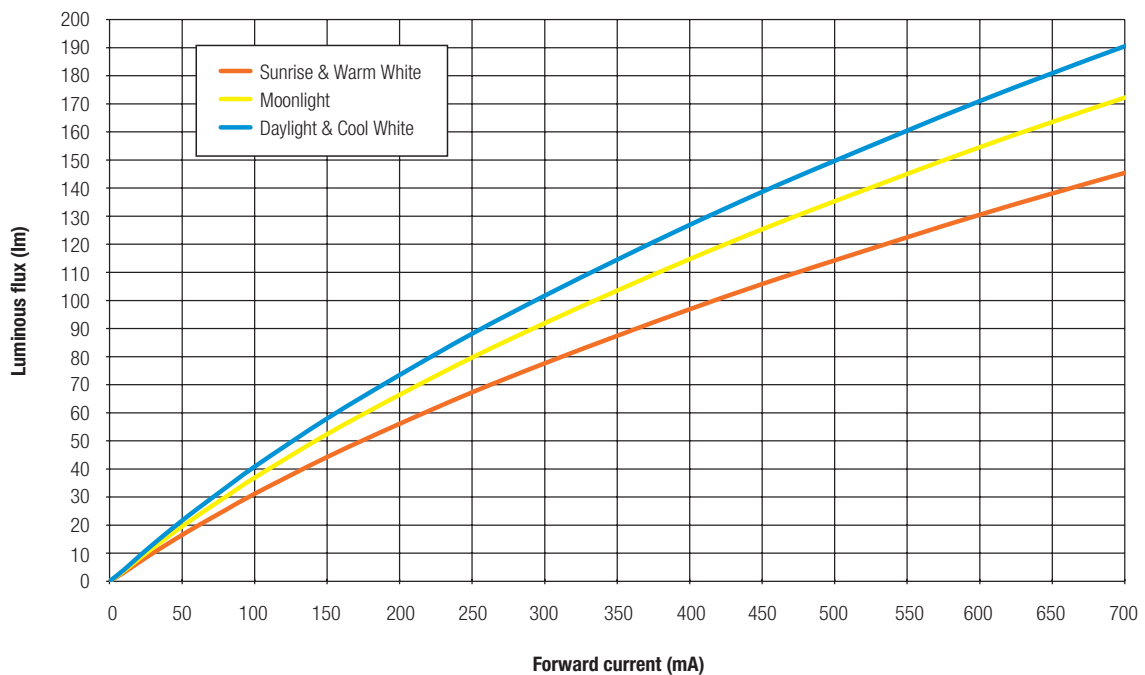

WL-SWTP

SMD White Top view PLCC LED

Size 3014, PLCC2



Characteristics

- Fast switching
- No IR radiation
- High CRI
- Slim and miniature size
- Low power consumption
- Suitable for all SMT assembly methods
- Top view
- Wide viewing angle
- Various color temperatures
- Thermal resistance junction to solder point: 38 °C/W
- LED junction temperature: 130 °C

Applications

- Signal lights
- Indoor displays
- Backlights
- General illumination, industrial and commercial lighting systems
- Replacement for PLCC 3528 in T8/T5

Electrical & Optical Characteristics @ 30 mA (typ.)

Order Code	Emitting color	CCT (K)	CRI	Φ_v (lm)	V_f (V)	Chip Technology	$2\theta_{50\%}$ (°)	Packaging (pcs.)
158301227	Sunrise	2700	80	10	3.2	GaN	120	Tape & reel 2000
158301230	Warm White	3000		10				
158301240	Moonlight	4000		11				
158301250	Daylight	5000		12				
158301260	Cool White	6000		12				

CCT = Correlated Color Temperature
 CRI = Color Rendering Index
 Φ_v = Luminous Flux
 V_f = Forward Voltage
 $2\theta_{50\%}$ = Viewing Angle

Dimensions (in mm)

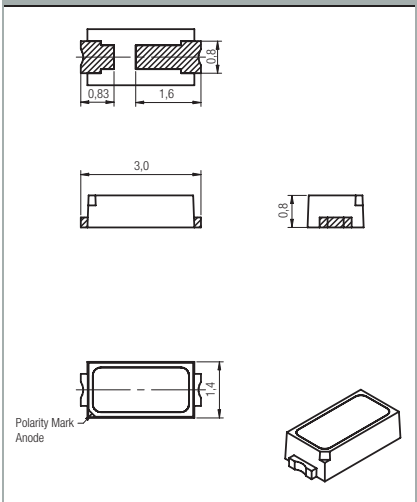

Viewing angle

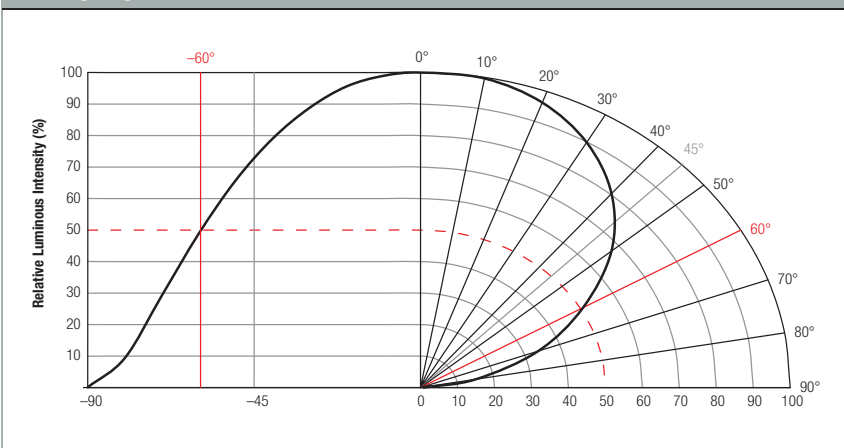

Recommended land pattern (in mm)

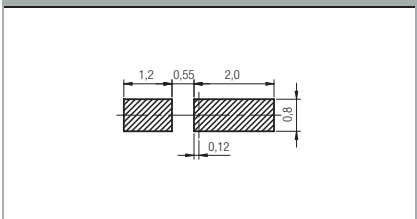

WL-SWTP SMD White Top view PLCC LED

Size 3014, PLCC2



Forward current vs. Forward voltage

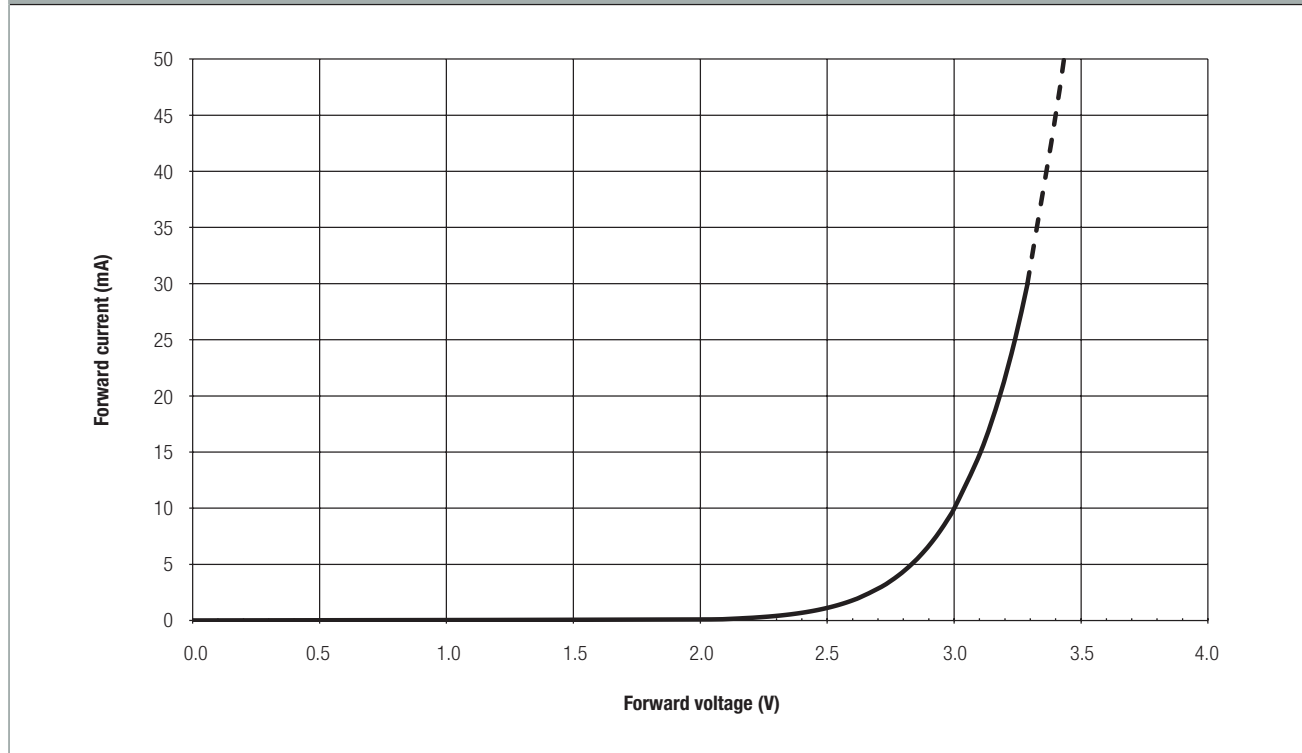

Luminous flux vs. Forward current

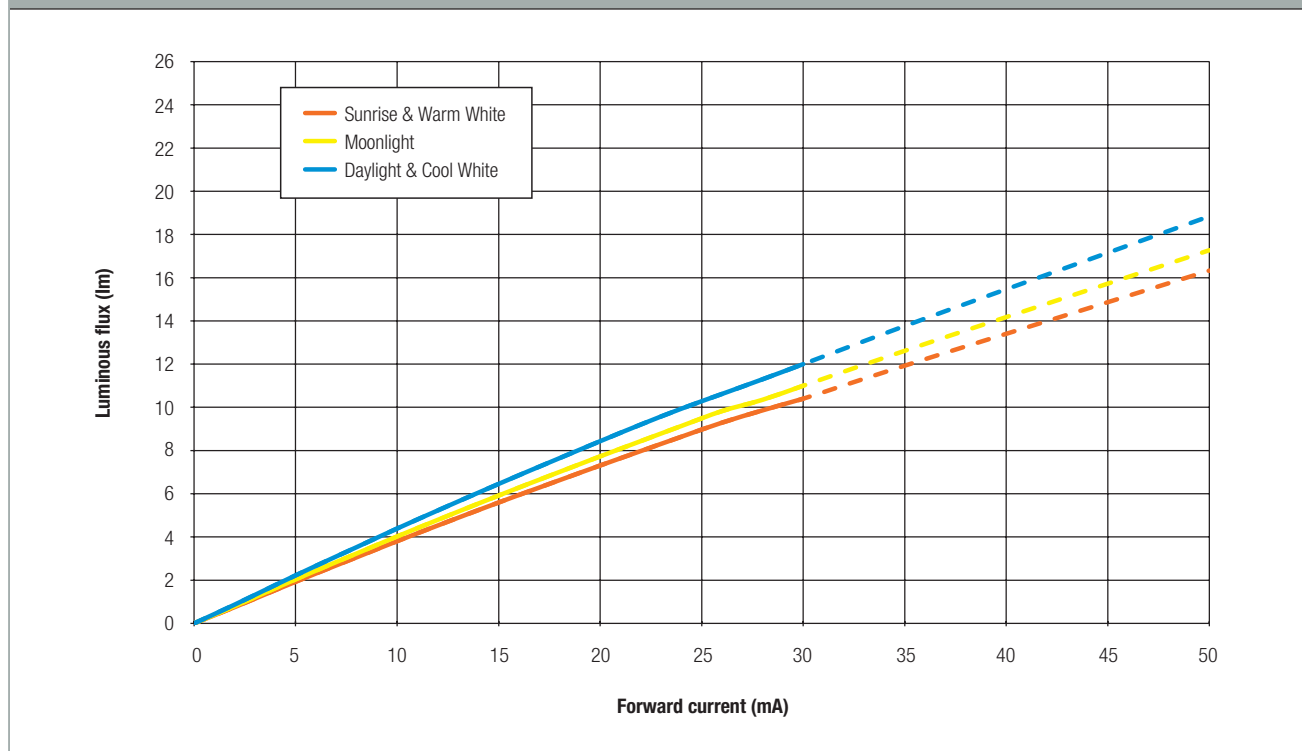

WL-SWTP

SMD White Top view PLCC LED

Size 3022, PLCC2



Characteristics

- Fast switching
- No IR radiation
- High CRI
- Compact form
- Low power consumption
- Suitable for all SMT assembly methods
- Top view
- Wide viewing angle
- Various color temperatures
- Thermal resistance junction to solder point: 38 °C/W
- LED junction temperature: 130 °C

Applications

- Decorative and Entertainment lighting
- Switch lights
- LED lighting fixtures
- LED decoration strips
- Indicator lights and backlighting for wireless mobile devices and consumer electronics
- Flat backlight for LCD
- LED backlighting and SMD type indicator lights
- LED Module
- General lighting

Electrical & Optical Characteristics @ 60 mA (typ.)

Order Code	Emitting color	CCT (K)	CRI	Φ_v (lm)	V_f (V)	Chip Technology	$2\theta_{50\%}$ (°)	Packaging (pcs.)
158302227	Sunrise	2700	80	20	3.2	InGaN	120	Tape & reel 2000
158302230	Warm White	3000		20				
158302240	Moonlight	4000		22				
158302250	Daylight	5000		22				
158302260	Cool White	6000		22				

CCT = Correlated Color Temperature
 CRI = Color Rendering Index
 Φ_v = Luminous Flux
 V_f = Forward Voltage
 $2\theta_{50\%}$ = Viewing Angle

Dimensions (in mm)

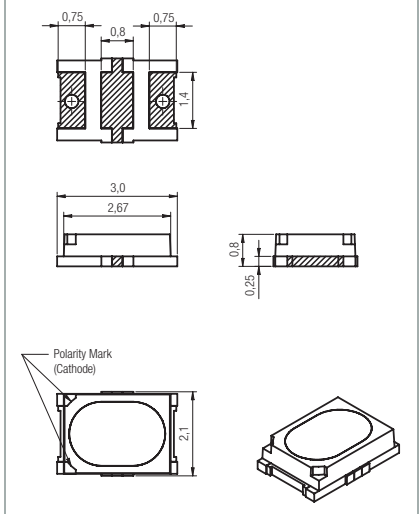

Viewing angle

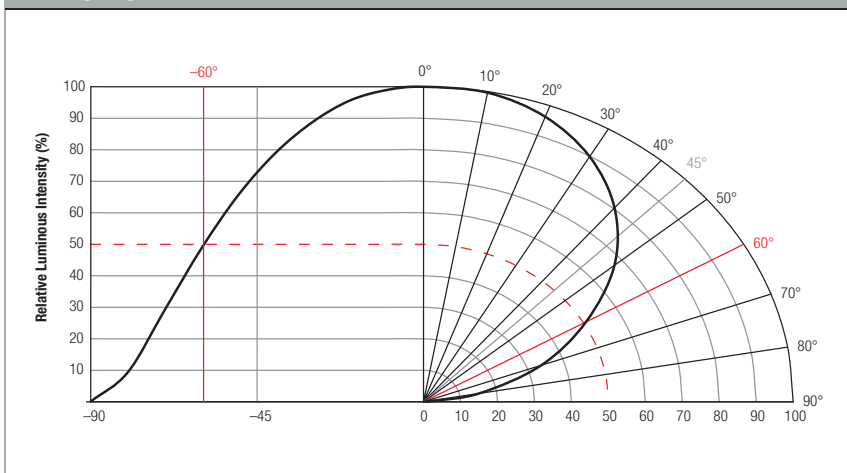

Recommended land pattern (in mm)

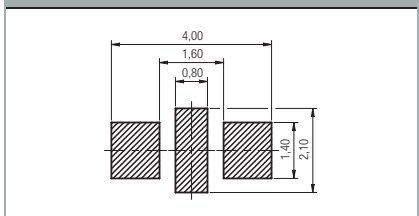

WL-SWTP

SMD White Top view PLCC LED

Size 3022, PLCC2



Forward current vs. Forward voltage

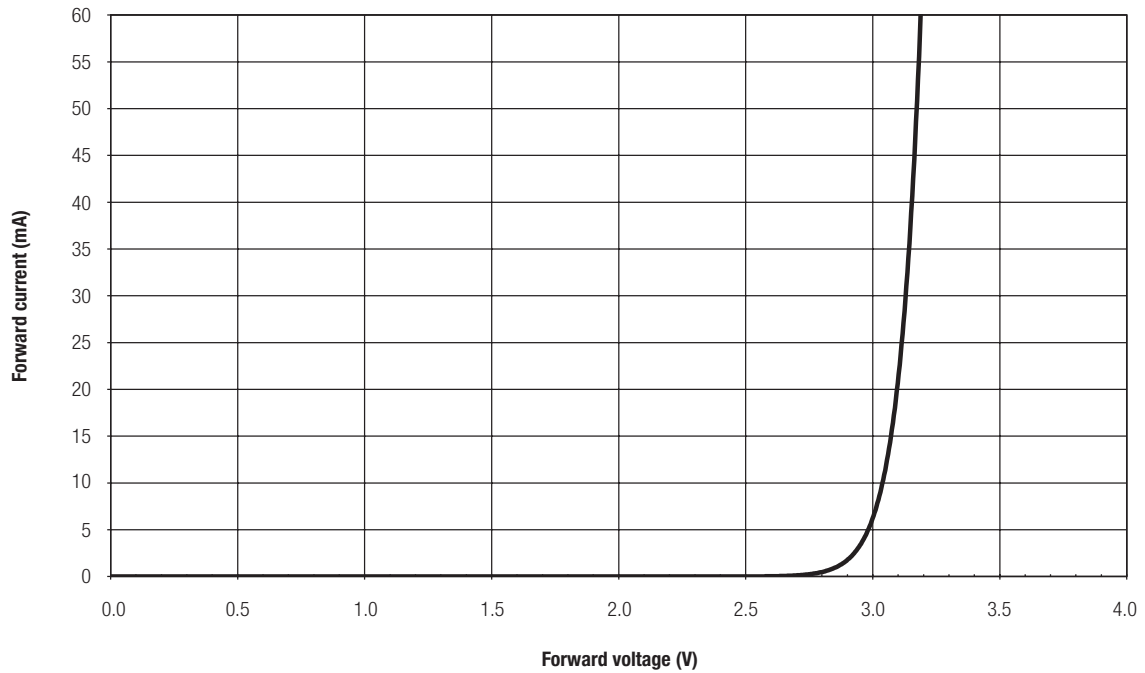

Luminous flux vs. Forward current

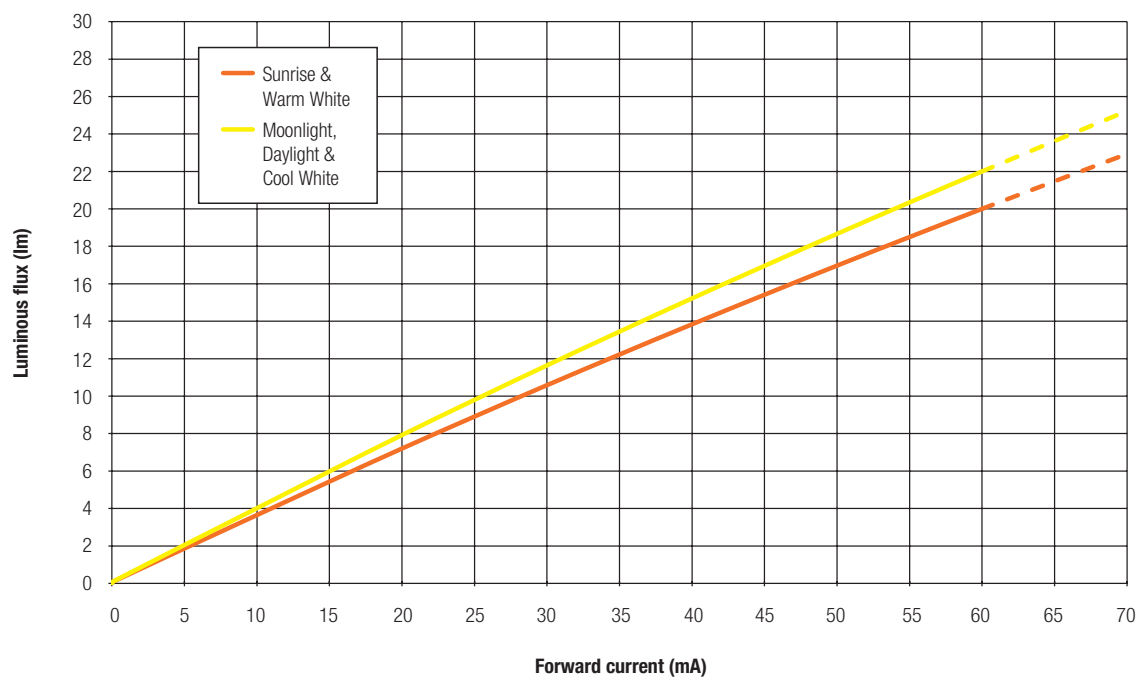

WL-SWTP

SMD White Top view PLCC LED

Size 5630, PLCC4



Characteristics

- Fast switching
- No IR radiation
- High CRI
- Excellent performance and visibility
- Suitable for all SMT assembly methods
- Top view
- Wide viewing angle
- Various color temperatures
- Thermal Resistance junction to solder point: 35 °C/W
- LED junction temperature: 130 °C

Applications

- Decorative and Entertainment lighting
- Light pipe application
- Indicator lights and backlighting for customer and industrial applications
- Indoor area lighting
- Downlight
- Outdoor and architectural lighting systems
- High bay & low bay
- Display & TV backlight

Electrical & Optical Characteristics @ 150 mA (typ.)

Order Code	Emitting color	CCT (K)	CRI	Φ_v (lm)	V_f (V)	Chip Technology	$2\theta_{50\%}$ (°)	Packaging (pcs.)
158563427	Sunrise	2700	80	45	3.2	InGaN	120	Tape & reel 2000
158563430	Warm White	3000		45				
158563440	Moonlight	4000		45				
158563450	Daylight	5000		50				
158563460	Cool White	6000		50				

CCT = Correlated Color Temperature
 CRI = Color Rendering Index
 Φ_v = Luminous Flux
 V_f = Forward Voltage
 $2\theta_{50\%}$ = Viewing Angle

Dimensions (in mm)

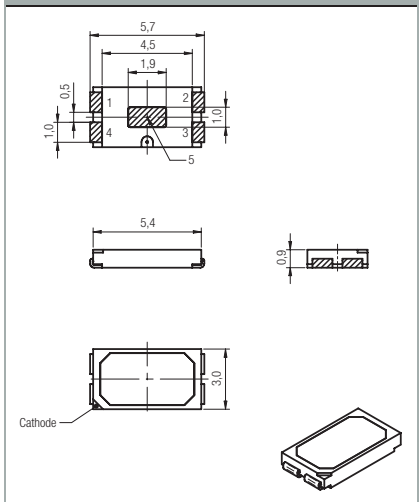

Viewing angle

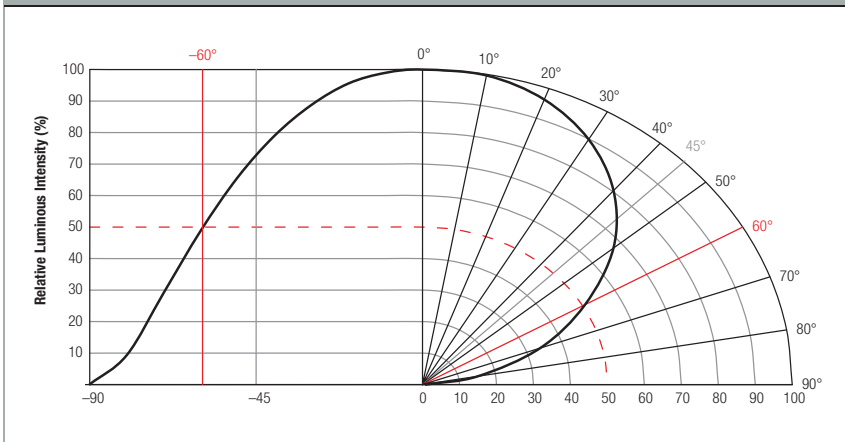

Recommended land pattern (in mm)

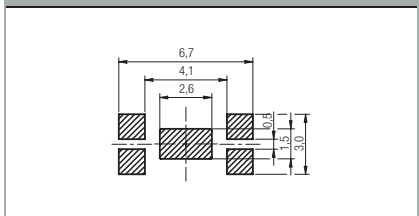

WL-SWTP

SMD White Top view PLCC LED

Size 5630, PLCC4



Forward current vs. Forward voltage

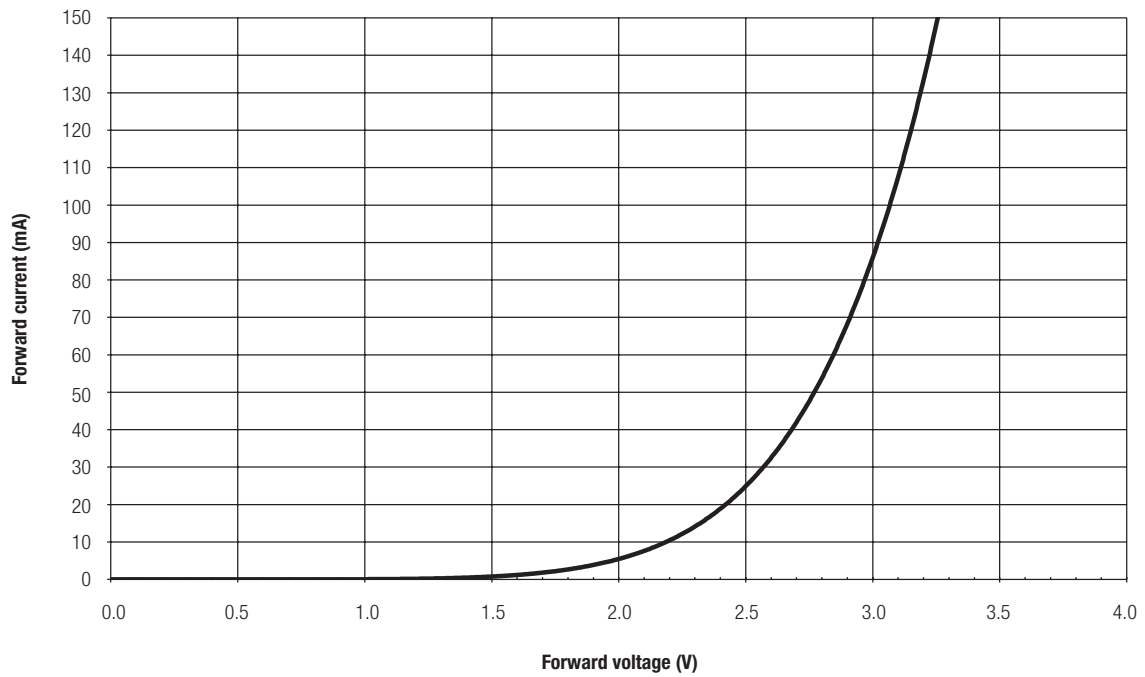

Luminous flux vs. Forward current

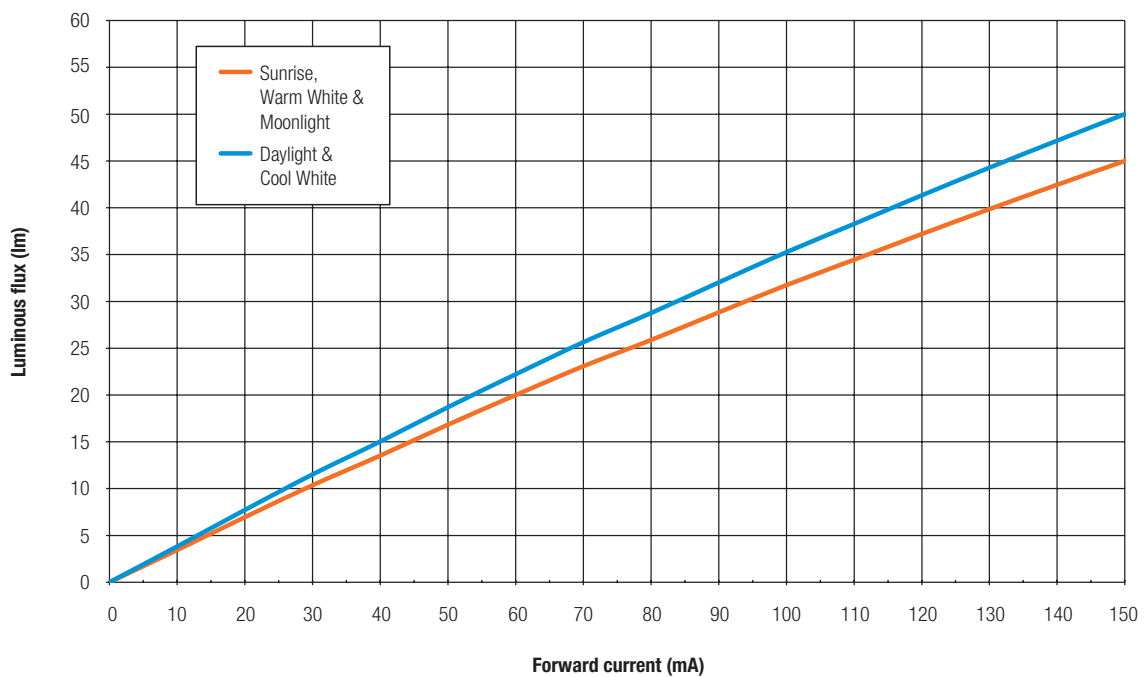

Chromaticity performance of WL-SWTC

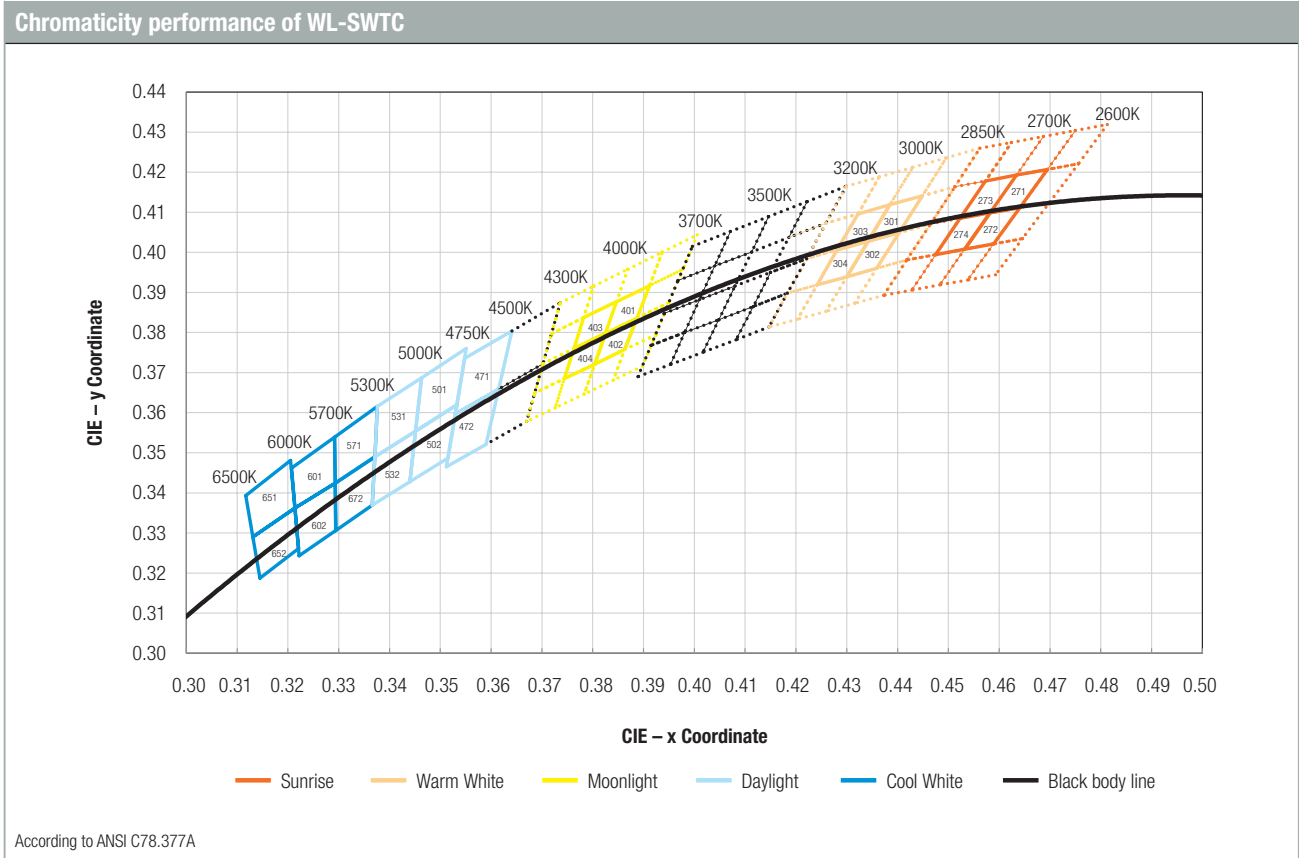

Order information:

The standard deliveries include values in the range and limitation as defined in the Electrical & Optical Properties specified in the datasheet. On each reel, only one bin is sorted and taped. The bin is defined on intensity, chromaticity coordinate or wavelength and forward voltage. In order to ensure highest availability, the reel binning of standard deliveries can vary. A single bin is not orderable.

Binning Table of WL-SWTC

Sunrise					
2600K–2700K	Cx	Cy		Cx	Cy
271	0.4582	0.4099	272	0.4532	0.4008
	0.4634	0.4193		0.4582	0.4099
	0.4695	0.4207		0.4641	0.4112
	0.4641	0.4112		0.4589	0.4021
	0.4582	0.4099		0.4532	0.4008
2700K–2850K	Cx	Cy		Cx	Cy
273	0.4523	0.4085	274	0.4475	0.3994
	0.4573	0.4178		0.4523	0.4085
	0.4634	0.4193		0.4582	0.4099
	0.4582	0.4099		0.4532	0.4008
	0.4523	0.4085		0.4475	0.3994

Warm white					
2850K–3000K	Cx	Cy		Cx	Cy
301	0.4342	0.4028	302	0.43	0.3939
	0.4385	0.4119		0.4342	0.4028
	0.4449	0.4141		0.4403	0.4049
	0.4403	0.4049		0.4359	0.396
	0.4342	0.4028		0.43	0.3939
3000K–3200K	Cx	Cy		Cx	Cy
303	0.4281	0.4006	304	0.4242	0.3919
	0.4322	0.4096		0.4281	0.4006
	0.4385	0.4119		0.4342	0.4028
	0.4342	0.4028		0.43	0.3939
	0.4281	0.4006		0.4242	0.3919

Moonlight					
3700K–4000K	Cx	Cy		Cx	Cy
401	0.3825	0.3798	402	0.3804	0.3721
	0.3847	0.3877		0.3825	0.3798
	0.3912	0.3917		0.3887	0.3836
	0.3887	0.3836		0.3863	0.3758
	0.3825	0.3798		0.3804	0.3721
4000K–4300K	Cx	Cy		Cx	Cy
403	0.3763	0.376	404	0.3744	0.3685
	0.3782	0.3837		0.3763	0.376
	0.3847	0.3877		0.3825	0.3798
	0.3825	0.3798		0.3804	0.3721
	0.3763	0.376		0.3744	0.3685

Daylight					
4500K–4750K	Cx	Cy		Cx	Cy
471	0.3529	0.3597	472	0.3512	0.3465
	0.3615	0.3659		0.359	0.3521
	0.3641	0.3804		0.3615	0.3659
	0.3548	0.3736		0.3529	0.3597
	0.3529	0.3597		0.3512	0.3465
4750K–5000K	Cx	Cy		Cx	Cy
501	0.3451	0.3554	502	0.344	0.3428
	0.3463	0.3687		0.3451	0.3554
	0.3551	0.376		0.3533	0.362
	0.3533	0.362		0.3515	0.3487
	0.3451	0.3554		0.344	0.3428
5000K–5300K	Cx	Cy		Cx	Cy
531	0.3371	0.349	532	0.3366	0.3369
	0.3376	0.3616		0.3371	0.349
	0.3463	0.3687		0.3451	0.3554
	0.3451	0.3554		0.344	0.3428
	0.3371	0.349		0.3366	0.3369

Cool white					
5300K–5700K	Cx	Cy		Cx	Cy
571	0.3293	0.3424	572	0.3294	0.3306
	0.3292	0.3539		0.3293	0.3424
	0.3376	0.3616		0.3371	0.349
	0.3371	0.349		0.3366	0.3369
	0.3293	0.3424		0.3294	0.3306
5700K–6000K	Cx	Cy		Cx	Cy
601	0.3214	0.3362	602	0.3222	0.3243
	0.3207	0.3462		0.3214	0.3362
	0.3292	0.3539		0.3293	0.3424
	0.3293	0.3424		0.3294	0.3306
	0.3214	0.3362		0.3222	0.3243
6000K–6500K	Cx	Cy		Cx	Cy
651	0.3131	0.329	652	0.3145	0.3187
	0.3117	0.3393		0.3131	0.329
	0.3205	0.3481		0.3214	0.3362
	0.3214	0.3362		0.3221	0.3261
	0.3131	0.329		0.3145	0.3187

Chromaticity performance of WL-SWTP

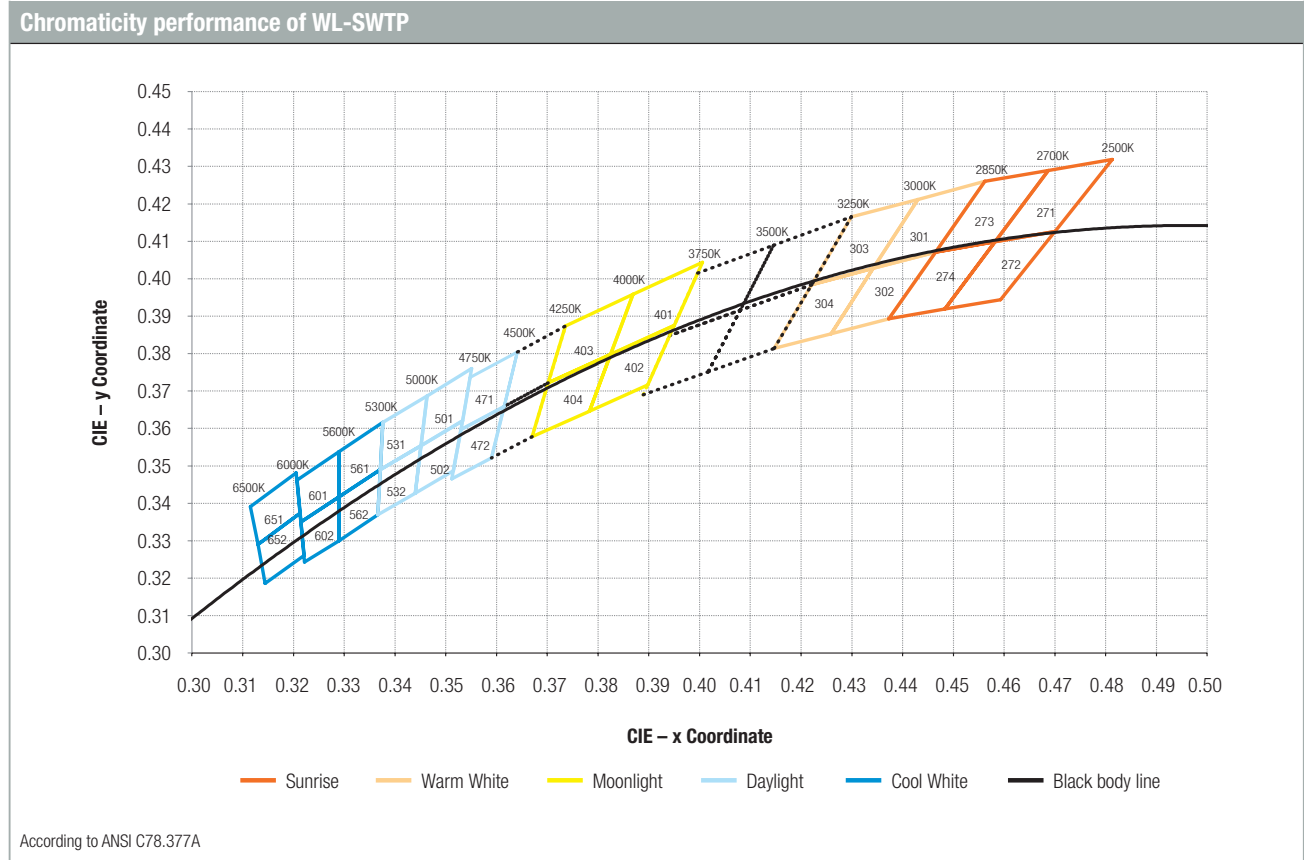

Order information:

The standard deliveries include values in the range and limitation as defined in the Electrical & Optical Properties specified in the datasheet. On each reel, only one bin is sorted and taped. The bin is defined on intensity, chromaticity coordinate or wavelength and forward voltage. In order to ensure highest availability, the reel binning of standard deliveries can vary. A single bin is not orderable.



Binning table of WL-SWTP

Sunrise					
2550K-2700K	Cx	Cy		Cx	Cy
271	0.4582	0.4099	272	0.4483	0.3919
	0.4687	0.4289		0.4582	0.4099
	0.4813	0.4319		0.47	0.4126
	0.47	0.4126		0.4593	0.3944
	0.4582	0.4099		0.4483	0.3919
2700K-2850K					
273	0.4465	0.4071	274	0.4373	0.3893
	0.4562	0.426		0.4465	0.4071
	0.4687	0.4289		0.4582	0.4099
	0.4582	0.4099		0.4483	0.3919
	0.4465	0.4071		0.4373	0.3893

Warm white					
2850K-3000K	Cx	Cy		Cx	Cy
301	0.4342	0.4028	302	0.4259	0.3853
	0.443	0.4212		0.4342	0.4028
	0.4562	0.426		0.4465	0.4071
	0.4465	0.4071		0.4373	0.3893
	0.4342	0.4028		0.4259	0.3853
3000K-3250K					
303	0.4147	0.3814	304	0.4221	0.3984
	0.4221	0.3984		0.4299	0.4165
	0.4342	0.4028		0.443	0.4212
	0.4259	0.3853		0.4342	0.4028
	0.4147	0.3814		0.4221	0.3984

Moonlight					
3750K-4000K	Cx	Cy		Cx	Cy
401	0.3825	0.3798	402	0.3783	0.3646
	0.3869	0.3958		0.3825	0.3798
	0.4006	0.4044		0.395	0.3875
	0.395	0.3875		0.3898	0.3716
	0.3825	0.3798		0.3783	0.3646
4000K-4250K					
403	0.3702	0.3722	404	0.367	0.3578
	0.3736	0.3874		0.3702	0.3722
	0.3869	0.3958		0.3825	0.3798
	0.3825	0.3798		0.3783	0.3646
	0.3702	0.3722		0.367	0.3578

Daylight					
4500K-4750K	Cx	Cy		Cx	Cy
471	0.353	0.3597	472	0.3512	0.3465
	0.3548	0.3736		0.353	0.3597
	0.3641	0.3804		0.3615	0.3659
	0.3615	0.3659		0.359	0.3521
	0.353	0.3597		0.3512	0.3465
4750K-5000K	Cx	Cy		Cx	Cy
501	0.3451	0.3554	502	0.344	0.3427
	0.3463	0.3687		0.3451	0.3554
	0.3551	0.376		0.3533	0.362
	0.3533	0.362		0.3515	0.3487
	0.3451	0.3554		0.344	0.3427
5000K-5300K	Cx	Cy		Cx	Cy
531	0.3366	0.3369	532	0.3371	0.349
	0.3371	0.349		0.3376	0.3616
	0.3451	0.3554		0.3463	0.3687
	0.344	0.3427		0.3451	0.3554
	0.3366	0.3369		0.3371	0.349

Cool white					
5300K-5600K	Cx	Cy		Cx	Cy
561	0.329	0.3417	562	0.329	0.33
	0.329	0.3538		0.329	0.3417
	0.3376	0.3616		0.3371	0.349
	0.3371	0.349		0.3366	0.3369
	0.329	0.3417		0.329	0.33
5600K-6000K	Cx	Cy		Cx	Cy
601	0.3215	0.335	602	0.3222	0.3243
	0.3207	0.3462		0.3215	0.335
	0.329	0.3538		0.329	0.3417
	0.329	0.3417		0.329	0.33
	0.3215	0.335		0.3222	0.3243
6000K-6500K	Cx	Cy		Cx	Cy
651	0.313	0.329	652	0.3144	0.3186
	0.3115	0.3391		0.313	0.329
	0.3205	0.3481		0.3213	0.3373
	0.3213	0.3373		0.3221	0.3261
	0.313	0.329		0.3144	0.3186

Electronic & Electromechanical Components



EMC Components



Power Magnetics



Power Modules

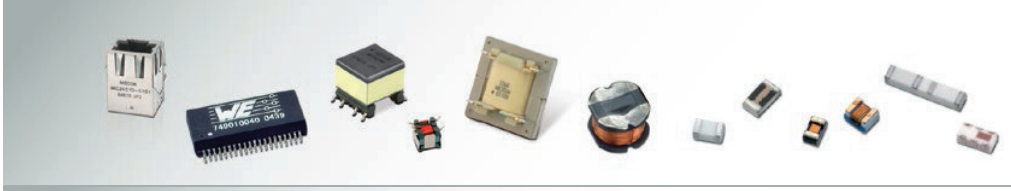

Signal & Communications



LED



Connectors



Switches



Assembly Technique



Power Elements

Looking for pricing, stock, or lifecycle information?

Click below to explore more details on WIN SOURCE:

 [View 158563430 on WIN SOURCE](#)

 [Wurth Electronics Inc](#) Information

Optimize Your Supply Chain with WIN SOURCE Solutions

-  Global Sourcing Solution
-  Obsolete Management
-  Cost Control Management
-  Shortage Management
-  Alternative Solution
-  Excess Inventory Management