



**THE DATASHEET OF
MAX14852GWE+**



MAX14852/MAX14854 2.75kV_{RMS} Isolated 500kbps/25Mbps Full-Duplex RS-485/RS-422 Transceivers with ±35kV ESD Protection

General Description

The MAX14852/MAX14854 isolated RS-485/RS-422 transceivers provide 2750V_{RMS} (60s) of galvanic isolation between the cable side (RS-485/RS-422 driver/receiver side) and the UART side of the device. Isolation improves communication by breaking ground loops and reduces noise when there are large differences in ground potential between ports. These devices allow for robust communication up to 500kbps (MAX14852) or 25Mbps (MAX14854).

The devices include one drive channel and one receive channel. The receiver is 1/4-unit load, allowing up to 128 transceivers on a common bus.

Integrated true fail-safe circuitry ensures a logic-high on the receiver output when inputs are shorted or open. Undervoltage lockout disables the driver when cable side or UART-side power supplies are below functional levels.

The driver outputs and receiver inputs are protected from ±35kV electrostatic discharge (ESD) to GNDB on the cable side, as specified by the Human Body Model (HBM).

The MAX14852/MAX14854 are available in a wide-body 16-pin SOIC package and operate over the -40°C to +105°C temperature range.

Functional Diagram

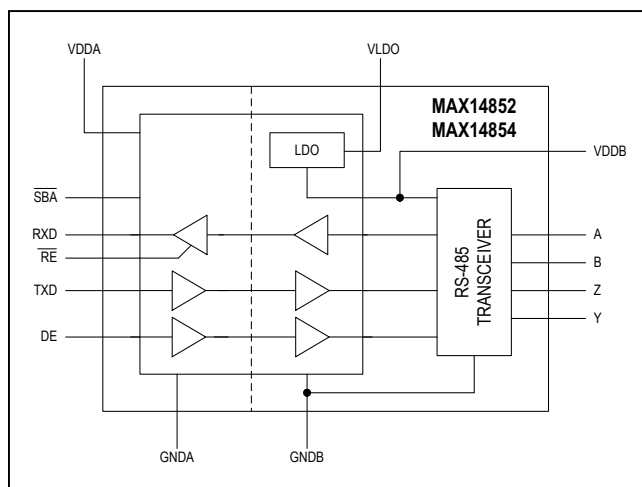

Benefits and Features

- High-Performance Transceiver Enables Flexible Designs
 - Integrated LDO for Cable Side Power
 - Compliant with RS-485 EIA/TIA-485 Standard
 - 500kbps (MAX14852)/25Mbps (MAX14854) Maximum Data Rate
 - Allows Up to 128 Devices on the Bus
- Integrated Protection Ensures for Robust Communication
 - ±35kV ESD (HBM) on Driver Outputs/Receiver Inputs
 - 2.75kV_{RMS} Withstand Isolation Voltage for 60 Seconds (V_{ISO})
 - 630V_{PEAK} Maximum Repetitive Peak-Isolation Voltage (V_{IORM})
 - 445V_{RMS} Maximum Working-Isolation Voltage (V_{IOWM})
 - > 30 Years Lifetime at Rated Working Voltage
 - Withstands ±10kV Surge per IEC 61000-4-5
 - Thermal Shutdown

Safety Regulatory Approvals Pending

- UL According to UL1577
- cUL According to CSA Bulletin 5A

Applications

- Industrial Automation Equipment
- Programmable Logic Controllers
- HVAC
- Power Meters

Ordering Information appears at end of data sheet.

Absolute Maximum Ratings

| | | | |
|---|------------------------------------|--|-----------------|
| V _{DDA} to GNDA | -0.3V to +6V | Continuous Power Dissipation (T _A = +70°C) 16-pin Wide SOIC (derate 14.1mW/°C above +70°C)..... | 1126.8mW |
| V _{DDB} to GNDB | -0.3V to +6V | | |
| V _{LDO} to GNDB | -0.3V to +16V | Operating Temperature Range | -40°C to +105°C |
| TXD, DE, \overline{RE} to GNDA | -0.3V to +6V | Junction Temperature | +150°C |
| \overline{SBA} , RXD to GNDA | -0.3V to (V _{DDA} + 0.3V) | Storage Temperature Range | -65°C to +150°C |
| A, B, Z, Y to GNDB | -8V to +13V | Lead Temperature (soldering, 10s) | +300°C |
| Short Circuit Duration (RXD, \overline{SBA} to GNDA, A, B, Y, Z, V _{DDB} to GNDB) | Continuous | Soldering Temperature (reflow) | +260°C |

Stresses beyond those listed under "Absolute Maximum Ratings" may cause permanent damage to the device. These are stress ratings only, and functional operation of the device at these or any other conditions beyond those indicated in the operational sections of the specifications is not implied. Exposure to absolute maximum rating conditions for extended periods may affect device reliability.

Package Thermal Characteristics (Note 1)

| | | | |
|---|--------|--|--------|
| Junction-to-Ambient Thermal Resistance (θ _{JA}) | 71°C/W | Junction-to-Case Thermal Resistance (θ _{JC}) | 23°C/W |
|---|--------|--|--------|

Note 1: Package thermal resistances were obtained using the method described in JEDEC specification JESD51-7, using a four-layer board. For detailed information on package thermal considerations, refer to www.maximintegrated.com/thermal-tutorial.

DC Electrical Characteristics

(V_{DDA} - V_{GNDA} = 1.71V to 5.5V, V_{DDB} - V_{GNDB} = 3.0V to 5.5V, T_A = T_{MIN} to T_{MAX}, unless otherwise noted. Typical values are at V_{DDA} - V_{GNDA} = 3.3V, V_{DDB} - V_{GNDB} = 3.3V, V_{GNDA} = V_{GNDB}, and T_A = +25°C.) (Notes 2, 3)

| PARAMETER | SYMBOL | CONDITIONS | MIN | TYP | MAX | UNITS |
|---|----------------------|---|------|------|------|-------|
| POWER | | | | | | |
| Supply Voltage | V _{DDA} | | 1.71 | | 5.5 | V |
| | V _{DDB} | | 3.0 | | 5.5 | |
| Supply Current | I _{DDA} | V _{DDA} = 5V, DE = high, \overline{RE} = TXD = low, RXD unconnected, no load | | 3.9 | 6.6 | mA |
| | I _{DDB} | DE = high, \overline{RE} = TXD = low, RXD unconnected, no bus load, V _{DDB} = 3.3V | | 7 | 12.5 | |
| Undervoltage Lockout Threshold | V _{UVLOA} | V _{DDA} rising | 1.50 | 1.58 | 1.65 | V |
| | V _{UVLOB} | V _{DDB} rising | 2.55 | 2.7 | 2.85 | |
| Undervoltage Lockout Threshold Hysteresis | V _{UVHYSTA} | | | 50 | | mV |
| | V _{UVHYSTB} | | | 200 | | |
| LDO | | | | | | |
| LDO Supply Voltage | V _{LDO} | Relative to GNDB, LDO is on (Note 4) | 3.18 | | 14 | V |
| LDO Supply Current | I _{LDO} | DE = high, TXD = low, no bus load, V _{LDO} = 5.5V | | 7.5 | 12.9 | mA |
| LDO Output Voltage | V _{DDB} | | 3.0 | 3.3 | 3.6 | V |
| LDO Current Limit | | | | 300 | | mA |
| Load Regulation | | V _{LDO} = 3.3V, I _{LOAD} = 20mA to 40mA | | 0.19 | 1.7 | mV/mA |
| Line Regulation | | V _{LDO} = 3.3V to 14V, I _{LOAD} = 20mA | | 0.12 | 1.8 | mV/V |
| Dropout Voltage | | V _{LDO} = 3.18V, I _{DDB} = -120mA | | 100 | 180 | mV |

DC Electrical Characteristics (continued)

($V_{DDA} - V_{GNDA} = 1.71V$ to $5.5V$, $V_{DDB} - V_{GNDB} = 3.0V$ to $5.5V$, $T_A = T_{MIN}$ to T_{MAX} , unless otherwise noted. Typical values are at $V_{DDA} - V_{GNDA} = 3.3V$, $V_{DDB} - V_{GNDB} = 3.3V$, $V_{GNDA} = V_{GNDB}$, and $T_A = +25^{\circ}C$.) (Notes 2, 3)

| PARAMETER | SYMBOL | CONDITIONS | MIN | TYP | MAX | UNITS |
|--|-----------------|---|---------------------------------|------------------|------|-------|
| Load Capacitance | | Nominal value (Note 7) | 1 | | 10 | μF |
| LOGIC INTERFACE (TXD, RXD, DE, \overline{RE}, \overline{SBA}) | | | | | | |
| Input High Voltage | V_{IH} | \overline{RE} , TXD, DE to GND | $2.25V \leq V_{DDA} \leq 5.5V$ | 0.7 x V_{DDA} | | V |
| | | | $1.71V \leq V_{DDA} \leq 1.89V$ | 0.78 x V_{DDA} | | |
| Input Low Voltage | V_{IL} | \overline{RE} , TXD, DE to GND | $2.25V \leq V_{DDA} \leq 5.5V$ | 0.8 | | V |
| | | | $1.71V \leq V_{DDA} \leq 1.89V$ | 0.6 | | |
| Input Hysteresis | V_{HYS} | \overline{RE} , TXD, DE to GND | | 220 | | mV |
| Input Capacitance | C_{IN} | \overline{RE} , TXD, DE, f = 1MHz | | 2 | | pF |
| Input Pullup Current | I_{PU} | TXD | -10 | -4.5 | -1.5 | μA |
| Input Pulldown Current | I_{PD} | DE, \overline{RE} | 1.5 | 4.5 | 10 | μA |
| \overline{SBA} Pullup Resistance | R_{SBA} | | 3 | 5 | 8 | kΩ |
| Output Voltage High | V_{OH} | RXD to GND, $I_{OUT} = -4mA$ | V_{DDA} -0.4 | | | V |
| Output Voltage Low | V_{OL} | RXD to GND, $I_{OUT} = 4mA$ | | | 0.40 | V |
| | | \overline{SBA} to GND, $I_{OUT} = 4mA$ | | | 0.45 | |
| Short-Circuit Output Pullup Current | I_{SH_PU} | $0V \leq V_{RXD} \leq V_{DDA}$, $(V_A - V_B) > -10mV$, $\overline{RE} = low$ | -42 | | | mA |
| Short-Circuit Output Pulldown Current | I_{SH_PD} | $0V \leq V_{RXD} \leq V_{DDA}$, $(V_A - V_B) < -200mV$, $\overline{RE} = low$ | | | 40 | mA |
| | | $0V \leq V_{\overline{SBA}} \leq V_{DDA}$, side B is powered and working | | | 60 | |
| Three-State Output Current | I_{OZ} | $0V \leq V_{RXD} \leq V_{DDA}$, $\overline{RE} = high$ | -1 | | +1 | μA |
| DRIVER | | | | | | |
| Differential Driver Output | $ V_{OD} $ | $R_L = 54\Omega$, TXD = high or low, Figure 1a | 1.5 | | | V |
| | | $R_L = 100\Omega$, TXD = high or low, Figure 1a | 2.0 | | | |
| | | $-7V \leq V_{CM} \leq +12V$, Figure 1b | 1.5 | | 5 | |
| Change in Magnitude of Differential Driver Output Voltage | ΔV_{OD} | $R_L = 100\Omega$ or 54Ω , Figure 1a (Note 5) | | | 0.2 | V |
| Driver Common-Mode Output Voltage | V_{OC} | $R_L = 100\Omega$ or 54Ω , Figure 1a (Note 5) | $V_{DDB}/2$ | | 3 | V |
| Change in Magnitude of Common-Mode Voltage | ΔV_{OC} | $R_L = 100\Omega$ or 54Ω , Figure 1a (Note 5) | | | 0.2 | V |

DC Electrical Characteristics (continued)

($V_{DDA} - V_{GNDA} = 1.71V$ to $5.5V$, $V_{DDB} - V_{GNDB} = 3.0V$ to $5.5V$, $T_A = T_{MIN}$ to T_{MAX} , unless otherwise noted. Typical values are at $V_{DDA} - V_{GNDA} = 3.3V$, $V_{DDB} - V_{GNDB} = 3.3V$, $V_{GNDA} = V_{GNDB}$, and $T_A = +25^{\circ}C$.) (Notes 2, 3)

| PARAMETER | SYMBOL | CONDITIONS | MIN | TYP | MAX | UNITS |
|---|-----------------|---|-----------------|------|------|-------------|
| Driver Short-Circuit Output Current | I_{OSD} | $GNDB \leq V_{OUT} \leq +12V$, output low (Note 6) | +30 | | +250 | mA |
| | | $-7V \leq V_{OUT} \leq V_{DDB}$, output high (Note 6) | -250 | | -30 | |
| Single-Ended Driver Output Voltage High | V_{OH} | Y and Z outputs, $I_{Y,Z} = -20mA$ | 2.2 | | | V |
| Single-Ended Driver Output Voltage Low | V_{OL} | Y and Z outputs, $I_{Y,Z} = +20mA$ | | | 0.8 | V |
| Differential Driver Output Capacitance | C_{OD} | $DE = \overline{RE} = \text{high}$, $f = 4MHz$ | | 12 | | pF |
| RECEIVER | | | | | | |
| Input Current (A and B) | I_A, I_B | $DE = \text{low}$, $V_{DDB} = GNDB$ or $3.6V$ | $V_{IN} = +12V$ | | +250 | μA |
| | | | $V_{IN} = -7V$ | -200 | | |
| Receiver Differential Threshold Voltage | V_{TH} | $-7V \leq V_{CM} \leq +12V$ | -200 | -120 | -10 | mV |
| Receiver Input Hysteresis | ΔV_{TH} | $V_{CM} = 0V$ | | 20 | | mV |
| Receiver Input Resistance | R_{IN} | $-7V \leq V_{CM} \leq +12V$, $DE = \text{low}$ | 48 | | | k Ω |
| Differential Input Capacitance | $C_{A,B}$ | Measured between A and B, $DE = \overline{RE} = \text{low}$ at $6MHz$ | | 12 | | pF |
| PROTECTION | | | | | | |
| Thermal-Shutdown Threshold | T_{SHDN} | Temperature Rising | | +160 | | $^{\circ}C$ |
| Thermal-Shutdown Hysteresis | T_{HYST} | | | 15 | | $^{\circ}C$ |
| ESD Protection (A and B Pins to GNDB) | | Human Body Model | | ±35 | | kV |
| | | IEC 61000-4-2 Air Gap Discharge | | ±18 | | |
| | | IEC 61000-4-2 Contact Discharge | | ±8 | | |
| ESD Protection (All Other Pins) | | Human Body Model | | ±4 | | kV |

Switching Electrical Characteristics (MAX14852)

($V_{DDA} - V_{GNDA} = 1.71V$ to $5.5V$, $V_{DDB} - V_{GNDB} = 3.0V$ to $5.5V$, $T_A = T_{MIN}$ to T_{MAX} , unless otherwise noted. Typical values are at $V_{DDA} - V_{GNDA} = 3.3V$, $V_{DDB} - V_{GNDB} = 3.3V$, $V_{GNDA} = V_{GNDB}$, and $T_A = +25^{\circ}C$.) (Note 7)

| PARAMETER | SYMBOL | CONDITIONS | MIN | TYP | MAX | UNITS |
|--|-------------------------|---|-----|-----|------|-------------|
| DYNAMIC | | | | | | |
| Common Mode Transient Immunity | CMTI | (Note 8) | | 35 | | kV/ μ s |
| Glitch Rejection | | TXD, DE, RXD | 10 | 17 | 29 | ns |
| DRIVER | | | | | | |
| Driver Propagation Delay | t_{DPLH} , t_{DPHL} | $R_L = 54\Omega$, $C_L = 50pF$, Figure 2 and Figure 3 | | | 1040 | ns |
| Differential Driver Output Skew $ t_{DPLH} - t_{DPHL} $ | t_{DSKEW} | $R_L = 54\Omega$, $C_L = 50pF$, Figure 2 and Figure 3 | | | 144 | ns |
| Driver Differential Output Rise or Fall Time | t_{LH} , t_{HL} | $R_L = 54\Omega$, $C_L = 50pF$, Figure 2 and Figure 3 | | | 900 | ns |
| Maximum Data Rate | DR_{MAX} | | 500 | | | kbps |
| Driver Enable to Output High | t_{DZH} | $R_L = 110\Omega$, $C_L = 50pF$, Figure 5 | | | 2540 | ns |
| Driver Enable to Output Low | t_{DZL} | $R_L = 110\Omega$, $C_L = 50pF$, Figure 5 | | | 2540 | ns |
| Driver Disable Time from Low | t_{DLZ} | $R_L = 110\Omega$, $C_L = 50pF$, Figure 5 | | | 140 | ns |
| Driver Disable Time from High | t_{DHZ} | $R_L = 110\Omega$, $C_L = 50pF$, Figure 4 | | | 140 | ns |
| RECEIVER | | | | | | |
| Receiver Propagation Delay | t_{RPLH} , t_{RPHL} | $C_L = 15pF$, Figure 6 and Figure 7 (Note 9) | | | 240 | ns |
| Receiver Output Skew $ t_{RPLH} - t_{RPHL} $ | t_{RSKEW} | $C_L = 15pF$, Figure 6 and Figure 7 (Note 9) | | | 34 | ns |
| Maximum Data Rate | DR_{MAX} | | 500 | | | kbps |
| Receiver Enable to Output High | t_{RZH} | $R_L = 1k\Omega$, $C_L = 15pF$, S2 closed, Figure 8 | | | 20 | ns |
| Receiver Enable to Output Low | t_{RZL} | $R_L = 1k\Omega$, $C_L = 15pF$, S1 closed, Figure 8 | | | 30 | ns |
| Receiver Disable Time From Low | t_{RLZ} | $R_L = 1k\Omega$, $C_L = 15pF$, S1 closed, Figure 8 | | | 20 | ns |
| Receiver Disable Time From High | t_{RHZ} | $R_L = 1k\Omega$, $C_L = 15pF$, S2 closed, Figure 8 | | | 20 | ns |

Switching Electrical Characteristics (MAX14854)

($V_{DDA} - V_{GNDA} = 1.71V$ to $5.5V$, $V_{DDB} - V_{GNDB} = 3.0V$ to $5.5V$, $T_A = T_{MIN}$ to T_{MAX} , unless otherwise noted. Typical values are at $V_{DDA} - V_{GNDA} = 3.3V$, $V_{DDB} - V_{GNDB} = 3.3V$, $V_{GNDA} = V_{GNDB}$, and $T_A = +25^\circ C$.) (Note 7)

| PARAMETER | SYMBOL | CONDITIONS | MIN | TYP | MAX | UNITS |
|--|-------------------------|---|-----|-----|-----|-------------|
| DYNAMIC | | | | | | |
| Common Mode Transient Immunity | CMTI | (Note 8) | | 35 | | kV/ μ s |
| Glitch Rejection | | TXD, DE, RXD | 10 | 17 | 29 | ns |
| DRIVER | | | | | | |
| Driver Propagation Delay | t_{DPLH} , t_{DPHL} | $R_L = 54\Omega$, $C_L = 50pF$, Figure 2 and Figure 3 | | | 65 | ns |
| Differential Driver Output Skew $ t_{DPLH} - t_{DPHL} $ | t_{DSKEW} | $R_L = 54\Omega$, $C_L = 50pF$, Figure 2 and Figure 3 | | | 7 | ns |
| Driver Differential Output Rise or Fall Time | t_{LH} , t_{HL} | $R_L = 54\Omega$, $C_L = 50pF$, Figure 2 and Figure 3 | | | 10 | ns |
| Maximum Data Rate | DR_{MAX} | | 25 | | | Mbps |
| Driver Enable to Output High | t_{DZH} | $R_L = 110\Omega$, $C_L = 50pF$, Figure 4 | | | 80 | ns |
| Driver Enable to Output Low | t_{DZL} | $R_L = 110\Omega$, $C_L = 50pF$, Figure 5 | | | 80 | ns |
| Driver Disable Time from Low | t_{DLZ} | $R_L = 110\Omega$, $C_L = 50pF$, Figure 5 | | | 80 | ns |
| Driver Disable Time from High | t_{DHZ} | $R_L = 110\Omega$, $C_L = 50pF$, Figure 4 | | | 80 | ns |
| RECEIVER | | | | | | |
| Receiver Propagation Delay | t_{RPLH} , t_{RPHL} | $C_L = 15pF$, Figure 6 and Figure 7 (Note 9) | | | 65 | ns |
| Receiver Output Skew $ t_{RPLH} - t_{RPHL} $ | t_{RSKEW} | $C_L = 15pF$, Figure 6 and Figure 7 (Note 9) | | | 7 | ns |
| Maximum Data Rate | DR_{MAX} | | 25 | | | Mbps |
| Receiver Enable to Output High | t_{RZH} | $R_L = 1k\Omega$, $C_L = 15pF$, S2 closed, Figure 8 | | | 20 | ns |
| Receiver Enable to Output Low | t_{RZL} | $R_L = 1k\Omega$, $C_L = 15pF$, S1 closed, Figure 8 | | | 30 | ns |
| Receiver Disable Time From Low | t_{RLZ} | $R_L = 1k\Omega$, $C_L = 15pF$, S1 closed, Figure 8 | | | 20 | ns |
| Receiver Disable Time From High | t_{RHZ} | $R_L = 1k\Omega$, $C_L = 15pF$, S2 closed, Figure 8 | | | 20 | ns |

Note 2: All devices are 100% production tested at $T_A = +25^\circ C$. Specifications over temperature are guaranteed by design.

Note 3: All currents into the device are positive. All currents out of the device are negative. All voltages are referenced to their respective ground (GNDA or GNDB), unless otherwise noted.

Note 4: V_{LDO} max indicates voltage capability of the circuit. Power dissipation requirements may limit V_{LDO} max to a lower value.

Note 5: ΔV_{OD} and ΔV_{OC} are the changes in V_{OD} and V_{OC} , respectively, when the TXD input changes state.

Note 6: The short circuit output current applies to the peak current just prior to current limiting.

Note 7: Not production tested. Guaranteed by design.

Note 8: CMTI is the maximum sustainable common-mode voltage slew rate while maintaining the correct output states. CMTI applies to both rising and falling common-mode voltage edges. Tested with the transient generator connected between GNDA and GNDB. $V_{CM} = 1kV$

Note 9: Capacitive load includes test probe and fixture capacitance.

Insulation Characteristics

| PARAMETER | SYMBOL | CONDITIONS | VALUE | UNITS |
|---|-------------------|---|------------------|------------------|
| Partial Discharge Test Voltage | V _{PR} | Method B1 = V _{IORM} × 1.875 (t = 1s, partial discharge < 5pC) | 1182 | V _P |
| Maximum Repetitive Peak Withstand Voltage | V _{IORM} | (Note 7) | 630 | V _P |
| Maximum Working Isolation Voltage | V _{IOWM} | (Note 7) | 445 | V _{RMS} |
| Maximum Transient Isolation Voltage | V _{IOTM} | t = 1s | 4600 | V _P |
| Maximum Withstand Isolation Voltage | V _{ISO} | t = 60s, f = 60Hz (Note 7, 8) | 2750 | V _{RMS} |
| Maximum surge Isolation Voltage | V _{IOSM} | IEC 61000-4-5, 1.2/50μs | 10 | kV |
| Insulation Resistance | R _S | T _A = +150°C, V _{IO} = 500V | >10 ⁹ | Ω |
| Barrier Capacitance Input to Output | C _{IO} | | 2 | pF |
| Creepage Distance | CPG | Wide SO | 8 | mm |
| Clearance Distance | CLR | Wide SO | 8 | mm |
| Internal Clearance | | Distance through insulation | 0.015 | mm |
| Comparitive Tracking Resistance Index | CTI | Material Group II (IEC 60112) | 575 | |
| Climatic Category | | | 40/125/21 | |
| Pollution Degree (DIN VDE 0110, Table 1) | | | 2 | |

Note 10: V_{IORM}, V_{IOWM}, and V_{ISO} are defined by the IEC 60747-5-5 standard.

Note 11: Product is qualified at V_{ISO} for 60 seconds. 100% production tested at 120% of V_{ISO} for 1 second.

Safety Regulatory Approvals

| |
|--|
| UL |
| The MAX14852/MAX14854 is certified under UL1577. For more details, see File E351759. |
| Rate up to 2750V _{RMS} isolation voltage for basic insulation. |
| cUL |
| The MAX14852/MAX14854 is certified under UL1577. For more details, see File E351759. Rate up to 2750V _{RMS} isolation voltage for basic insulation. |

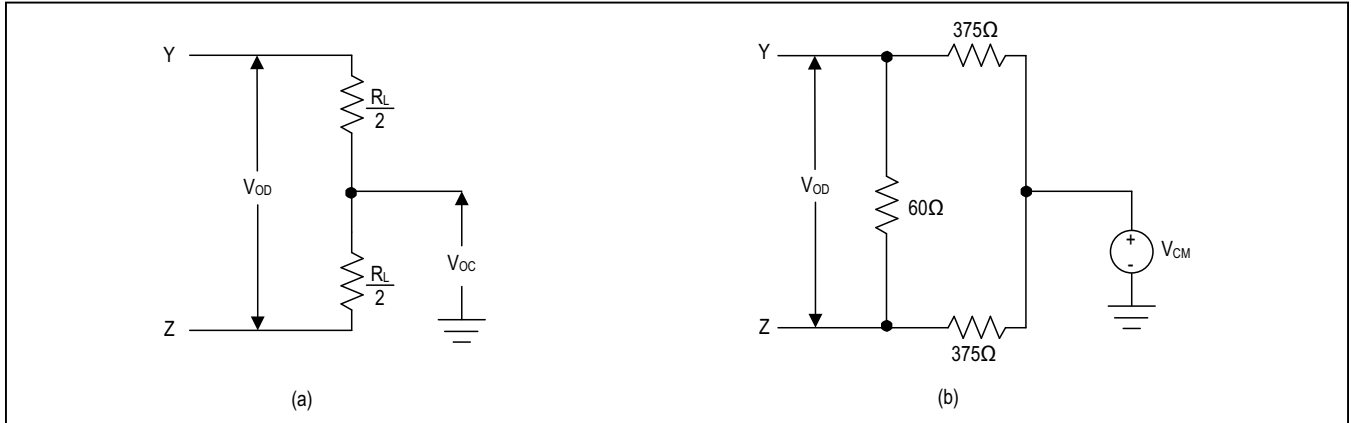

Figure 1. Driver DC Test Load

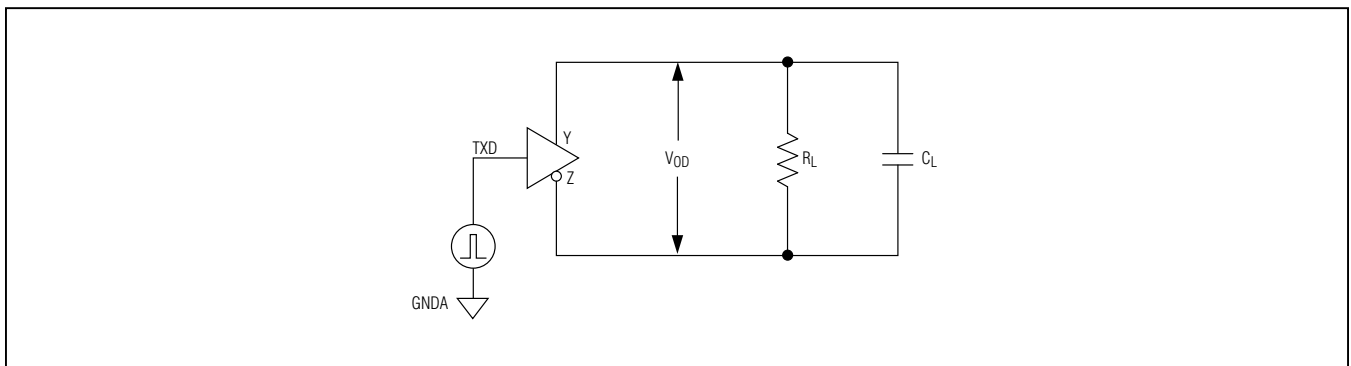

Figure 2. Driver Timing Test Circuit

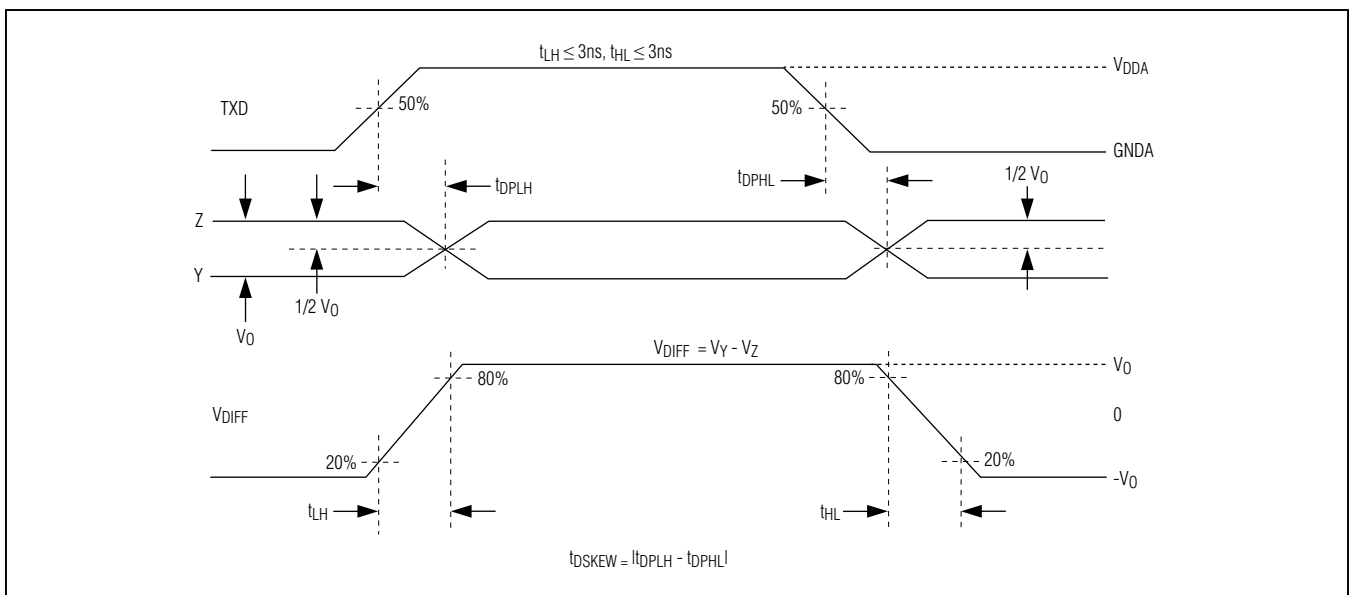

Figure 3. Driver Propagation Delays

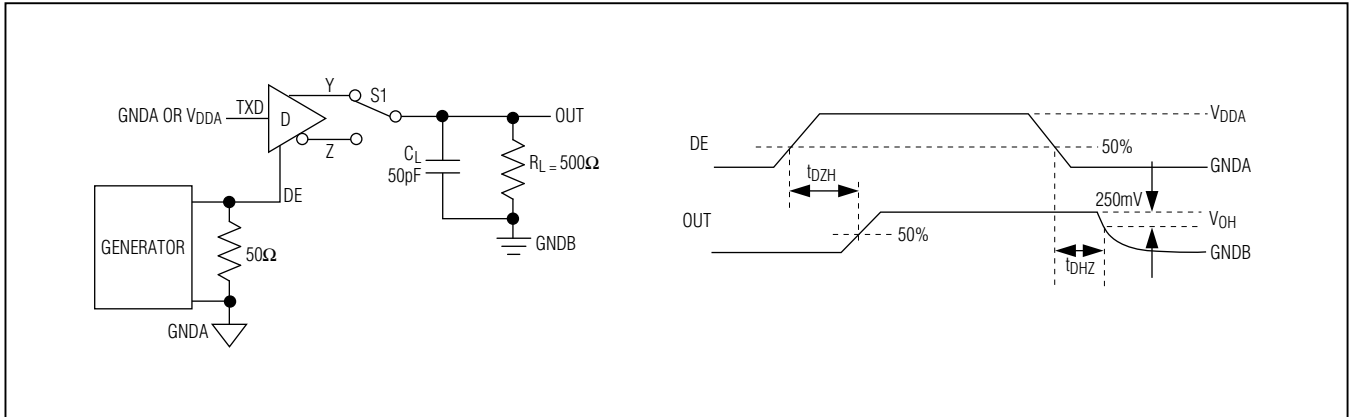

Figure 4. Driver Enable and Disable Times (t_{DZH} , t_{DHZ})

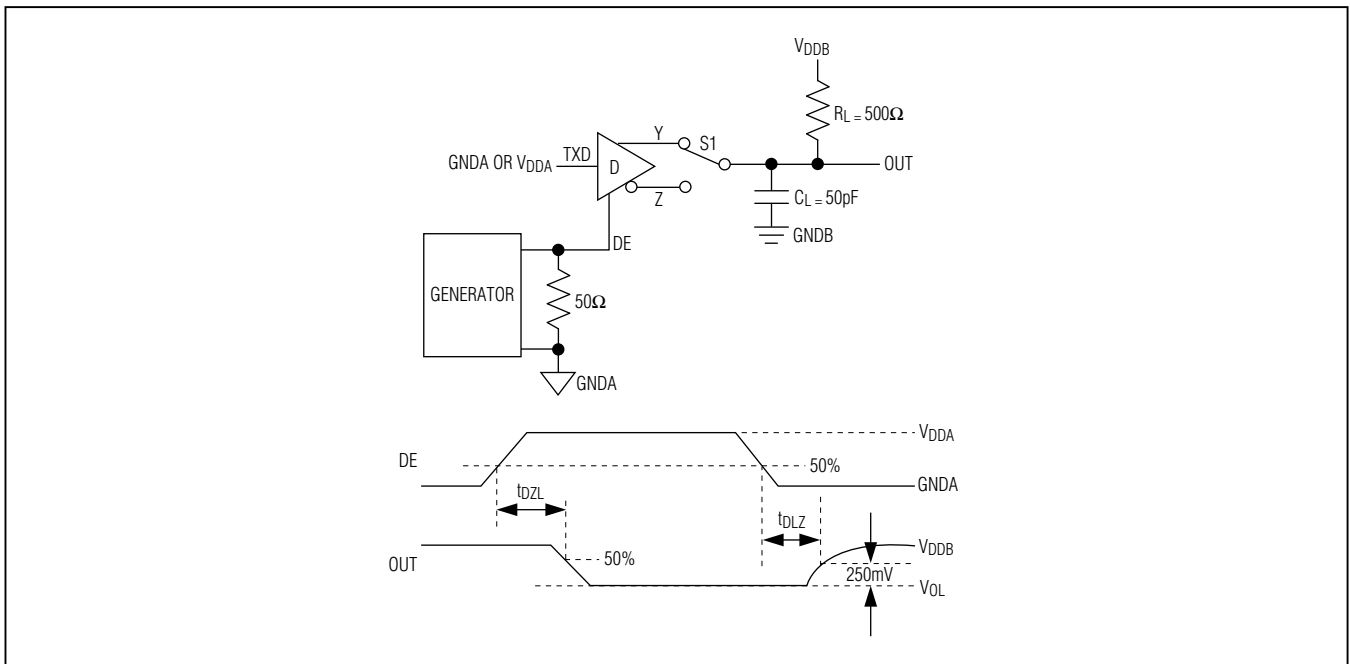

Figure 5. Driver Enable and Disable Times (t_{DZL} , t_{DLZ})

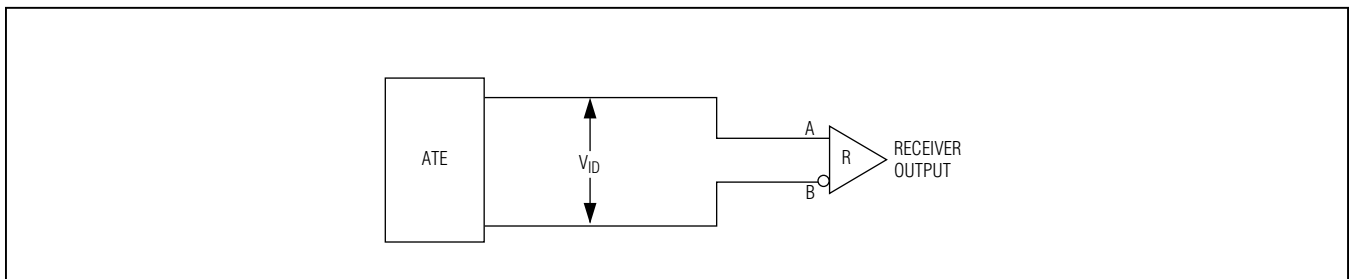

Figure 6. Receiver Propagation Delay Test Circuit

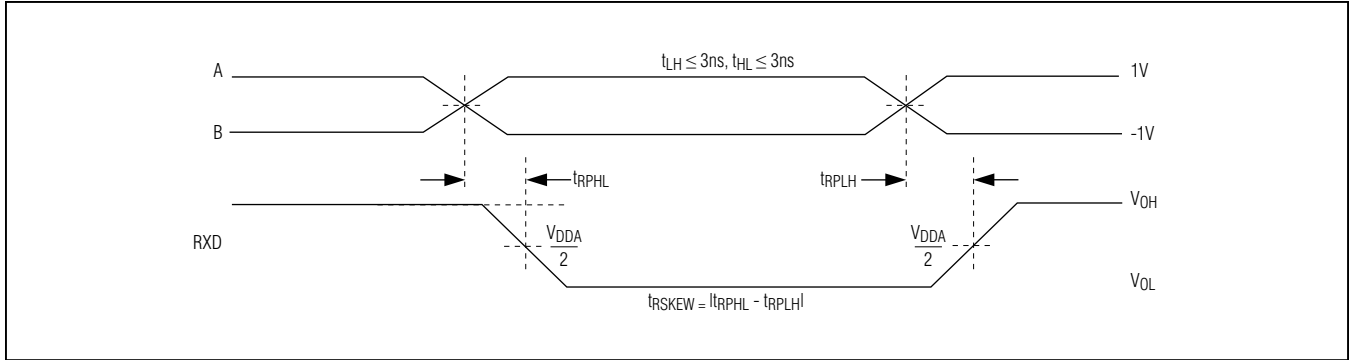

Figure 7. Receiver Propagation Delays

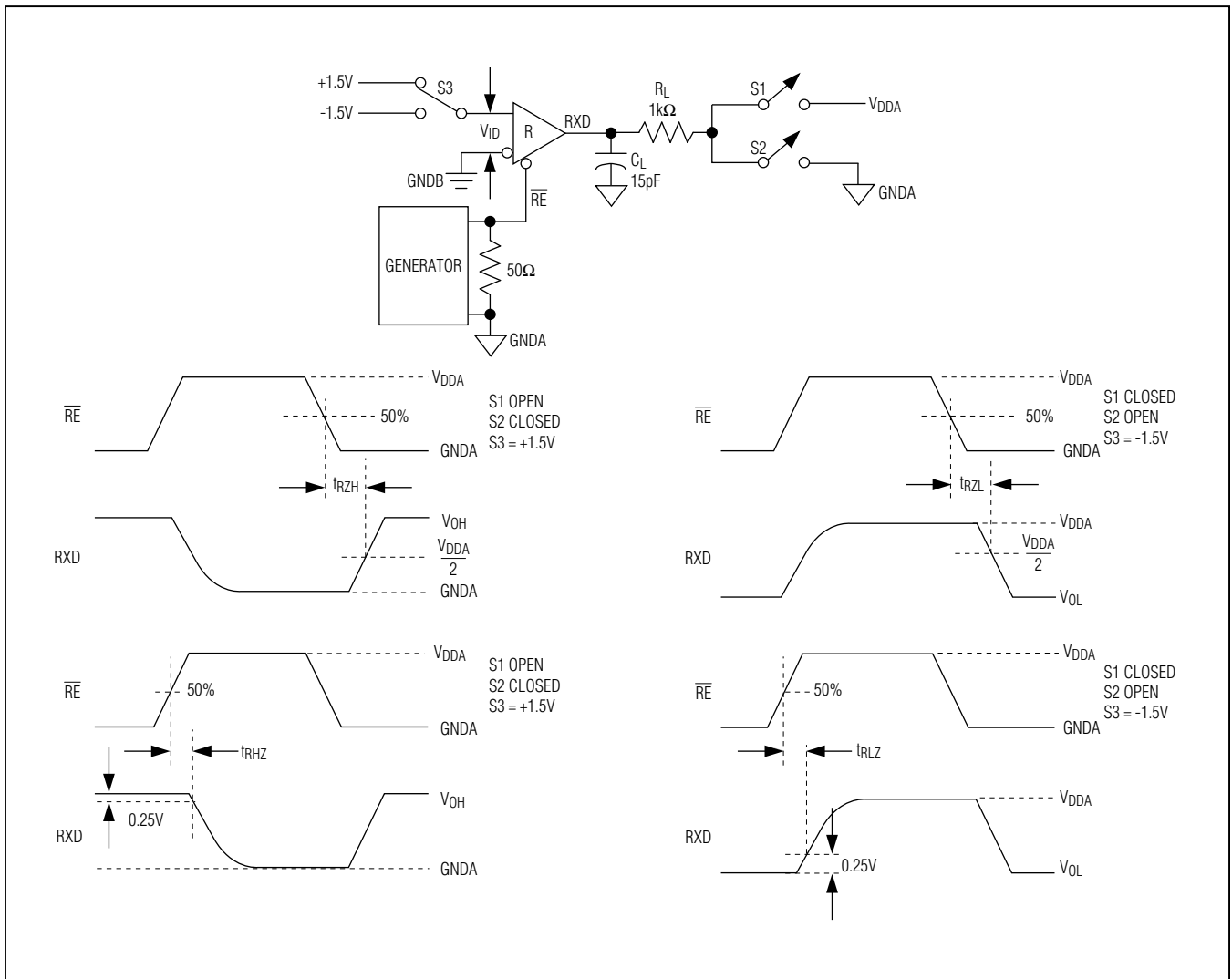
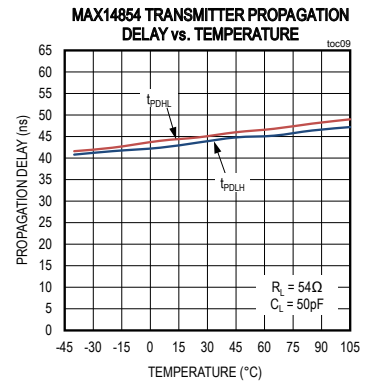
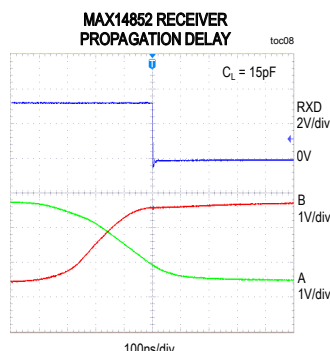
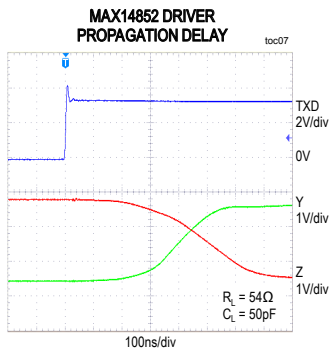
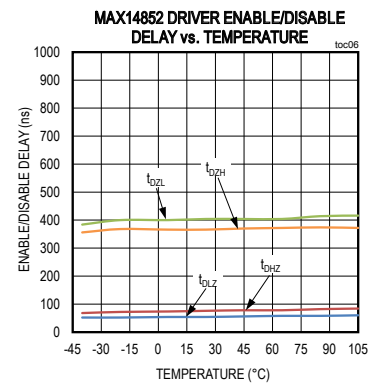
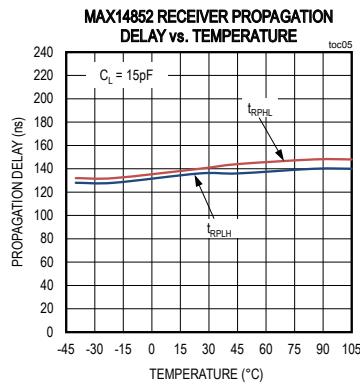
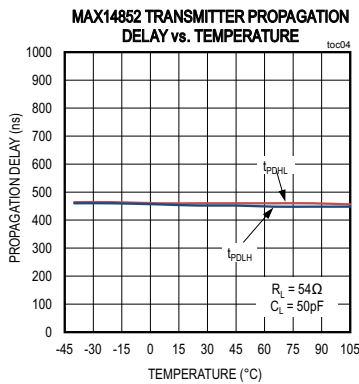
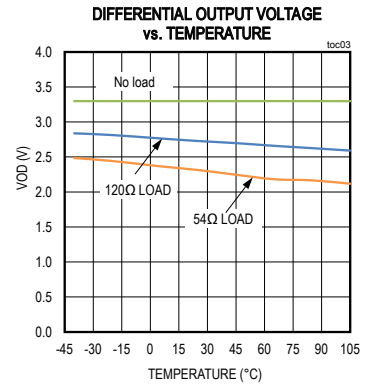
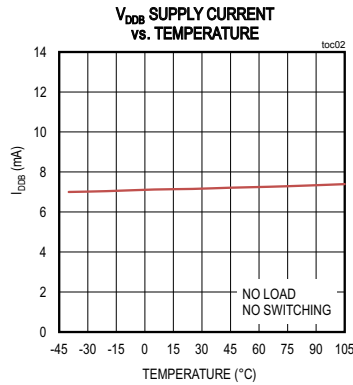
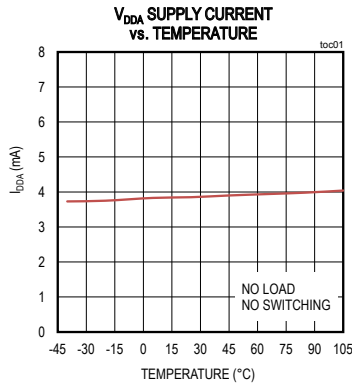

Figure 8. Receiver Enable and Disable Times

Typical Operating Characteristics

($V_{DDA} - V_{GNDA} = 3.3V$, $V_{DDB} - V_{GNDB} = 3.3V$, $V_{GNDA} = V_{GNDB}$, and $T_A = +25^\circ C$, unless otherwise noted.)



Typical Operating Characteristics (continued)

($V_{DDA} - V_{GNDA} = 3.3V$, $V_{DDB} - V_{GNDB} = 3.3V$, $V_{GNDA} = V_{GNDB}$, and $T_A = +25^\circ C$, unless otherwise noted.)

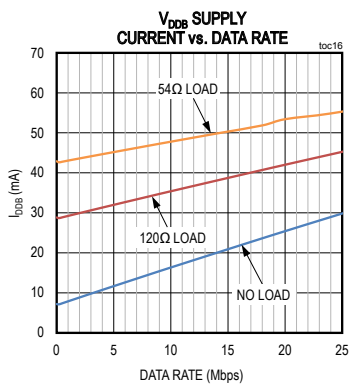
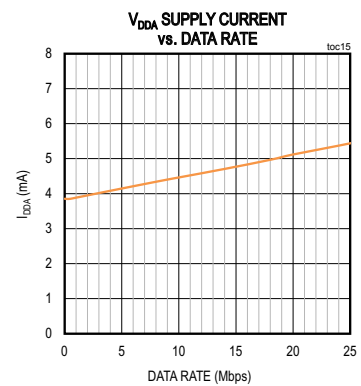
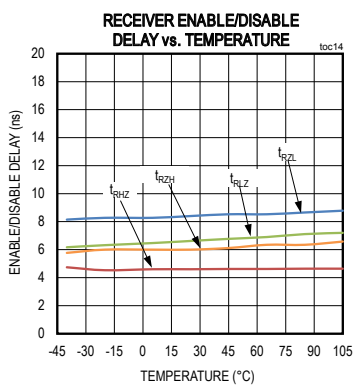
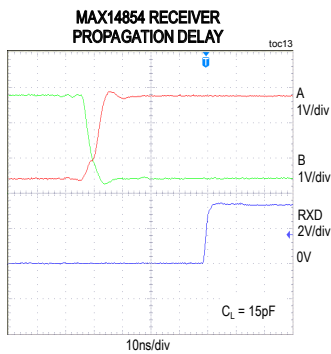
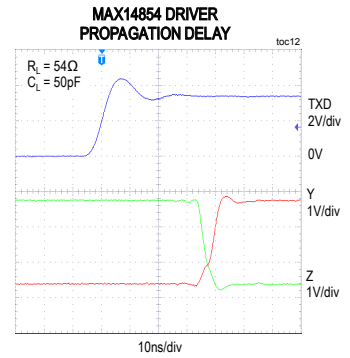
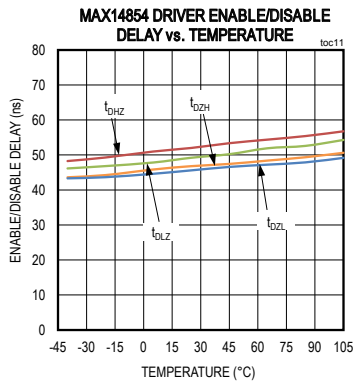
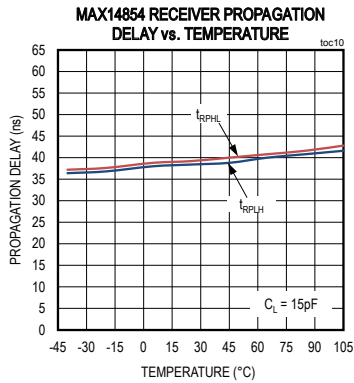

Pin Configuration

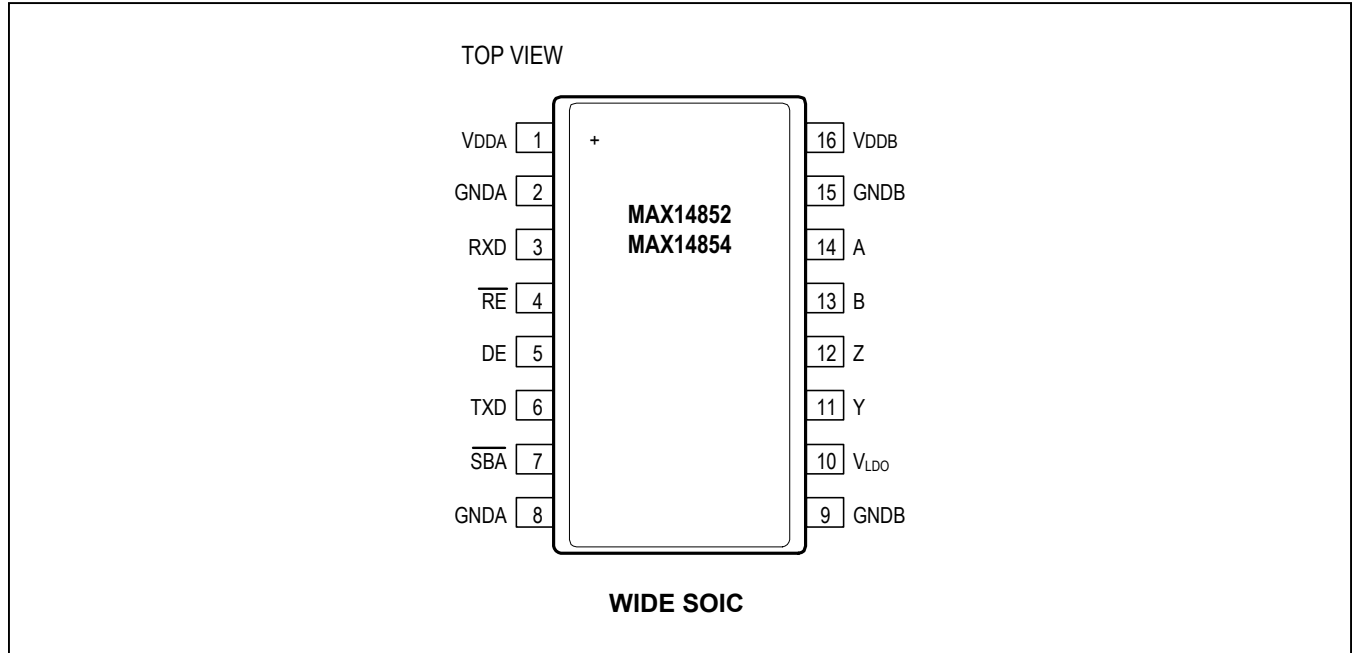

Pin Description

| PIN | NAME | REFERENCE | FUNCTION |
|------|------------------|-----------|--|
| 1 | V _{DDA} | GNDA | UART/Logic-Side Power Input. Bypass V _{DDA} to GNDA with both 0.1µF and 1µF capacitors as close to the device as possible. |
| 2, 8 | GNDA | - | UART/Logic-Side Ground. GNDA is the ground reference for digital signals. |
| 3 | RXD | GNDA | Receiver Data Output. Drive RE low to enable RXD. With RE low, RXD is high when (V _A - V _B) > -10mV and is low when (V _A - V _B) < -200mV. RXD is high when V _{DDB} is less than V _{UVLOB} . RXD is high impedance when RE is high. |
| 4 | RE | GNDA | Receiver Output Enable. Drive RE low or connect to GNDA to enable RXD. Drive RE high to disable RXD. RXD is high-impedance when RE is high. RE has an internal 4.5µA pull-down to GNDA. |
| 5 | DE | GNDA | Driver Output Enable. Drive DE high to enable bus driver outputs Y and Z. Drive DE low or connect to GNDA to disable Y and Z. Y and Z are high impedance when DE is low. DE has an internal 4.5µA pull-down to GNDA. |
| 6 | TXD | GNDA | Driver Input. With DE high, a low on TXD forces the noninverting output (Y) low and the inverting output (Z) high. Similarly, a high on TXD forces the noninverting output high and the inverting output low. TXD has an internal 4.5µA pull-up to V _{DDA} . |
| 7 | SBA | GNDA | Side B Active Indicator Output. SBA asserts low when side B is powered and working. SBA has an internal 5kΩ pull-up resistor to V _{DDA} . |

Pin Description (continued)

| PIN | NAME | REFERENCE | FUNCTION |
|-------|------|-----------|---|
| 9, 15 | GNDB | - | Cable Side Ground. GNDB is the ground reference for the internal LDO and the RS-485/RS-422 bus signals. |
| 10 | VLDO | GNDB | LDO Power Input. Connect a minimum voltage of 3.18V to VLDO to power the cable side of the transceiver. Bypass VLDO to GNDB with both 0.1µF and 1µF capacitors as close to the device as possible. To disable the internal LDO, leave VLDO unconnected or connect to GNDB. |
| 11 | Y | GNDB | Noninverting Driver Output |
| 12 | Z | GNDB | Inverting Driver Output |
| 13 | B | GNDB | Inverting Receiver Input |
| 14 | A | GNDB | Noninverting Receiver Input |
| 16 | VDDB | GNDB | Cable Side Power Input/Isolated LDO Power Output. Bypass VDDB to GNDB with both 0.1µF and 1µF capacitor as close to the device as possible. VDDB is the output of the internal LDO when power is applied to VLDO. When the internal LDO is not used (VLDO is unconnected or connected to GNDB), VDDB is the positive supply input for the cable side of the IC. |

Function Tables

| TRANSMITTING | | | | | |
|----------------------|----------------------|----|-----|---------|--------|
| INPUTS | | | | OUTPUTS | |
| V _{DDA} | V _{DDB} | DE | TXD | Y | Z |
| ≥ V _{UVLOA} | ≥ V _{UVLOB} | 1 | 1 | 1 | 0 |
| ≥ V _{UVLOA} | ≥ V _{UVLOB} | 1 | 0 | 0 | 1 |
| ≥ V _{UVLOA} | ≥ V _{UVLOB} | 0 | X | High-Z | High-Z |
| < V _{UVLOA} | ≥ V _{UVLOB} | X | X | High-Z | High-Z |
| ≥ V _{UVLOA} | < V _{UVLOB} | X | X | High-Z | High-Z |
| < V _{UVLOA} | < V _{UVLOB} | X | X | High-Z | High-Z |

*Note: Drive DE low to disable the transmitter outputs. Drive DE high to enable the transmitter outputs. DE has an internal pull-down to GNDA.

X = Don't care

| RECEIVING | | | | |
|----------------------|----------------------|-----------------|------------------------------------|---------|
| INPUTS | | | | OUTPUTS |
| V _{DDA} | V _{DDB} | \overline{RE} | (V _A - V _B) | RXD |
| ≥ V _{UVLOA} | ≥ V _{UVLOB} | 0 | > -10mV | 1 |
| ≥ V _{UVLOA} | ≥ V _{UVLOB} | 0 | < -200mV | 0 |
| ≥ V _{UVLOA} | ≥ V _{UVLOB} | 0 | Open/Short | 1 |
| ≥ V _{UVLOA} | ≥ V _{UVLOB} | 1 | X | High-Z |
| < V _{UVLOA} | ≥ V _{UVLOB} | X | X | High-Z |
| ≥ V _{UVLOA} | < V _{UVLOB} | 0 | X | 1 |
| < V _{UVLOA} | < V _{UVLOB} | X | X | High-Z |

*Note: Drive \overline{RE} high to disable the receiver output. Drive \overline{RE} low to enable to receiver output. \overline{RE} has an internal pull-down to GNDA.

X = Don't care

| \overline{SBA} | | |
|----------------------|----------------------|------------------|
| V _{DDA} | V _{DDB} | \overline{SBA} |
| < V _{UVLOA} | < V _{UVLOB} | High |
| < V _{UVLOA} | ≥ V _{UVLOB} | High |
| ≥ V _{UVLOA} | < V _{UVLOB} | High |
| ≥ V _{UVLOA} | ≥ V _{UVLOB} | Low |

Detailed Description

The MAX14852/MAX14854 isolated RS-485/RS-422 transceivers provide 5000V_{RMS} (60s) of galvanic isolation between the RS-485/RS-422 cable side of the transceiver and the UART side. These devices allow up to 500kbps (MAX14852)/25Mbps (MAX14854) communication across an isolation barrier when a large potential exists between grounds on each side of the barrier.

Isolation

Data isolation is achieved using high-voltage capacitors that allow data transmission between the UART side and the RS-485/RS-422 cable side of the transceiver.

Integrated LDO

The devices include an internal low-dropout regulator with a set 3.3V (typ) output that is used to power the cable side of the IC. The output of the LDO is V_{DDB}. The LDO has a 300mA (typ) current limit. If the LDO is unused, connect V_{LDO} to GNDB and apply +3.3V directly to V_{DDB}.

True Fail-Safe

The devices guarantee a logic-high on the receiver output when the receiver inputs are shorted or open, or when connected to a terminated transmission line with all drivers disabled. The receiver threshold is fixed between -10mV and -200mV. If the differential receiver input voltage (V_A - V_B) is greater than or equal to -10mV, RXD is logic-high. In the case of a terminated bus with all transmitters disabled, the receiver's differential input voltage is pulled to zero by the termination resistors. Due to the receiver thresholds of the devices, this results in a logic-high at RXD.

Driver Output Protection

Two mechanisms prevent excessive output current and power dissipation caused by faults or bus contention. The first, a current limit on the output stage, provides immediate protection against short circuits over the entire common-mode voltage range. The second, a thermal-shutdown circuit, forces the driver outputs into a high-impedance state if the die temperature exceeds +160°C (typ).

Thermal Shutdown

The devices are protected from overtemperature damage by integrated thermal-shutdown circuitry. When the junction temperature (T_J) exceeds +160°C (typ), the driver outputs go high-impedance. The device resumes normal operation when T_J falls below +145°C (typ).

Applications Information

128 Transceivers on the Bus

The standard RS-485 receiver input impedance is one unit load. A standard driver can drive up to 32 unit-loads. The MAX14852/MAX14854 transceivers have a 1/4-unit load receiver, which allows up to 128 transceivers, connected in parallel, on one communication line. Connect any combination of these devices, and/or other RS-485 devices, for a maximum of 32 unit-loads to the line.

Typical Application

The MAX14852/MAX14854 full-duplex transceivers are designed for bidirectional data communications on multi-point bus transmission lines. [Figure 9](#) and [Figure 10](#) show typical network application circuits. To minimize reflections, the bus should be terminated at both ends in its characteristics impedance, and stub lengths off the main line should be kept as short as possible.

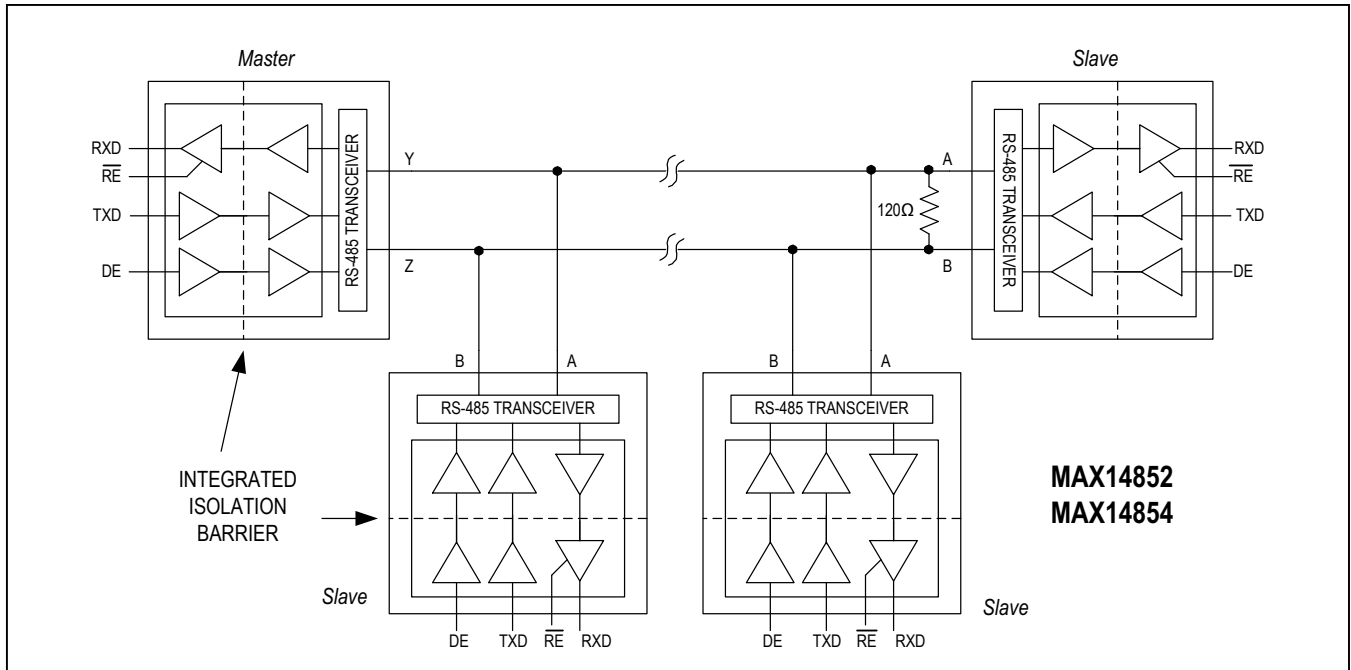

Figure 9. Typical Isolated Full-Duplex RS-485/RS-422 Application

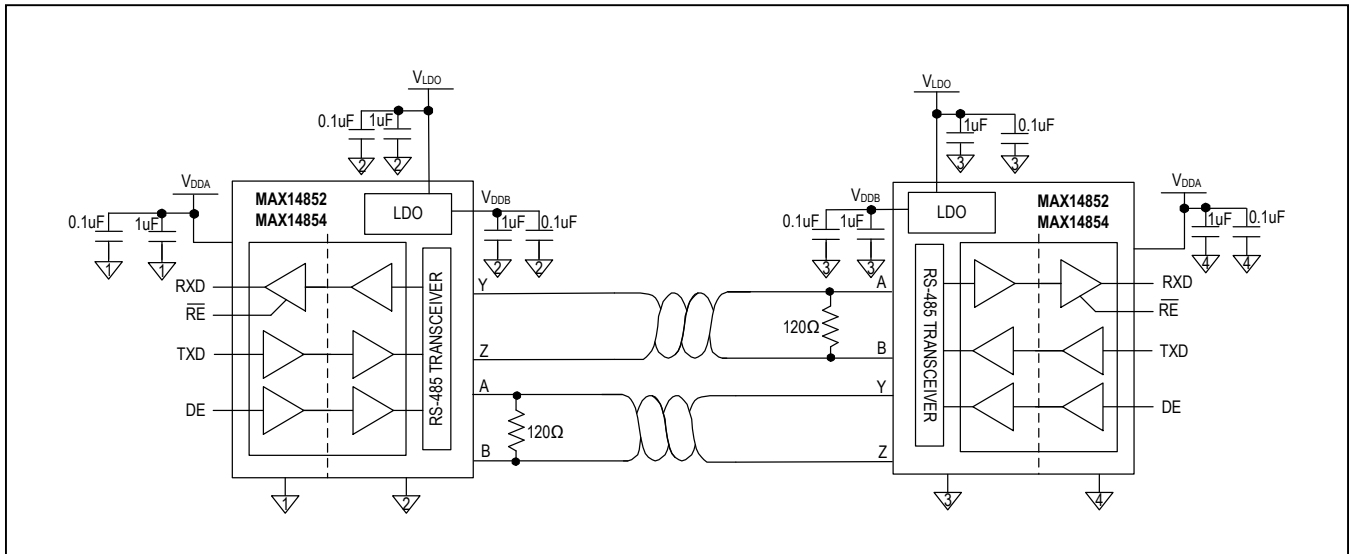

Figure 10. Typical Isolated Point-to-Point Application

Layout Considerations

It is recommended to design an isolation, or “keep-out,” channel underneath the isolator that is free from ground and signal planes. Any galvanic or metallic connection between the cable side and UART side will defeat the isolation.

Ensure that the decoupling capacitors between V_{DDA} and $GNDA$ and between V_{LDO} , V_{DDB} , and $GNDB$ are located as close as possible to the IC to minimize inductance.

Route important signal lines close to the ground plane to minimize possible external influences. On the cable side of the devices, it is good practice to have the bus connectors and termination resistor as close as possible to the A and B pins.

Extended ESD Protection

ESD protection structures are incorporated on all pins to protect against electrostatic discharge encountered during handling and assembly. The driver outputs and receiver inputs of the devices have extra protection against static electricity to both the UART side and cable side ground references. The ESD structures withstand high-ESD events during normal operation and when powered down. After an ESD event, the devices keep working without latch-up or damage.

Bypass V_{DDA} to $GNDA$ and bypass V_{DDB} and V_{LDO} to $GNDB$ with 0.1 μ F and 1 μ F capacitors to ensure maximum ESD protection.

ESD protection can be tested in various ways. The transmitter outputs and receiver inputs of the MAX14852/MAX14854 are characterized for protection to the cable side ground ($GNDB$) to the following limits:

- ±35kV HBM
- ±18kV using the Air-Gap Discharge method specified in IEC 61000-4-2
- ±8kV using the Contact Discharge method specified in IEC 61000-4-2

ESD Test Conditions

ESD performance depends on a variety of conditions. Contact Maxim for a reliability report that documents test setup, test methodology, and test results.

Human Body Model (HBM)

[Figure 11](#) shows the HBM test model, while [Figure 12](#) shows the current waveform it generates when discharged in a low-impedance state. This model consists of a 100pF capacitor charged to the ESD voltage of interest, which is then discharged into the test device through a 1.5k Ω resistor.

IEC 61000-4-2

The IEC 61000-4-2 standard covers ESD testing and performance of finished equipment. However, it does not specifically refer to integrated circuits. The devices help in designing equipment to meet IEC 61000-4-2 without the need for additional ESD protection components.

The major difference between tests done using the HBM and IEC 61000-4-2 is higher peak current in IEC 61000-4-2 because series resistance is lower in the IEC 61000-4-2 model. Hence, the ESD withstand voltage measured to IEC 61000-4-2 is generally lower than that measured using the HBM.

[Figure 13](#) shows the IEC 61000-4-2 model and [Figure 14](#) shows the current waveform for IEC 61000-4-2 ESD Contact Discharge Test.

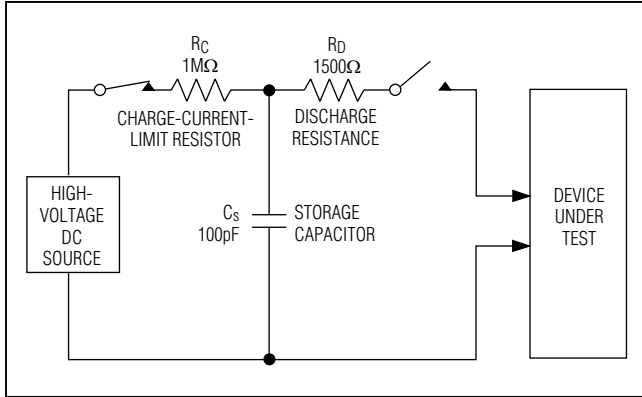

Figure 11. Human Body ESD Test Model

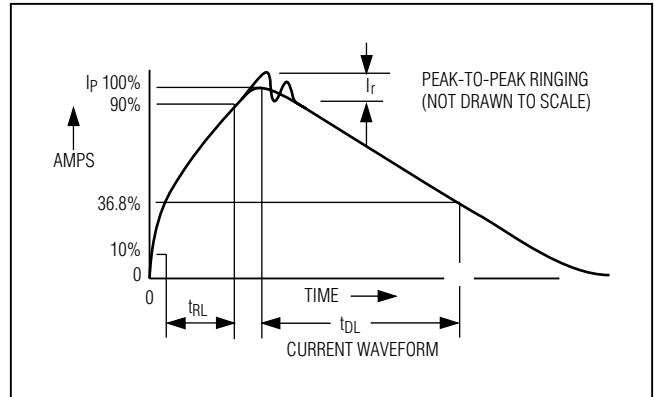

Figure 12. Human Body Current Waveform

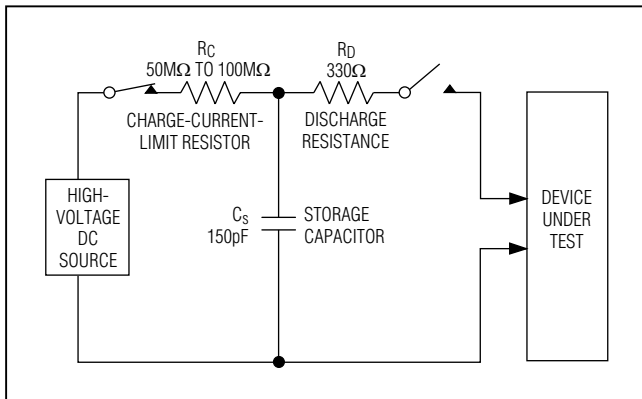

Figure 13. IEC 61000-4-2 ESD Test Model

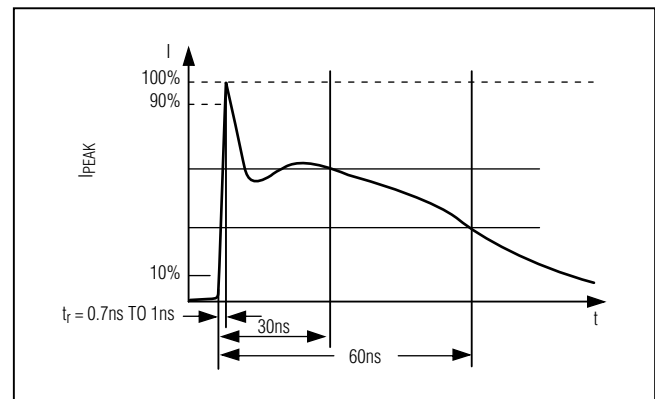
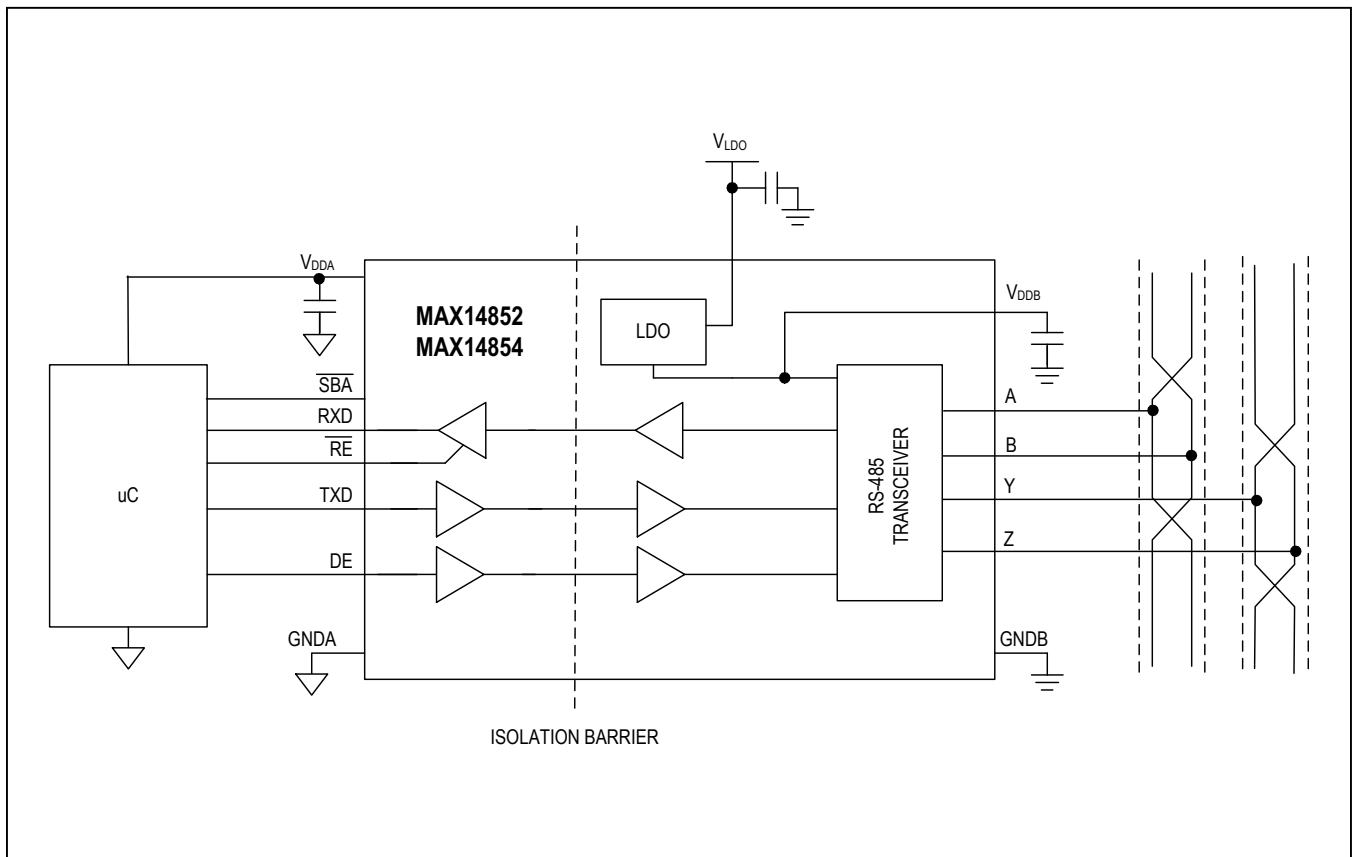

Figure 14. IEC 61000-4-2 ESD Generator Current Waveform

Typical Application Circuit



MAX14852/MAX14854

2.75kV_{RMS} Isolated 500kbps/25Mbps Full-Duplex
RS-485/RS-422 Transceivers
with ±35kV ESD Protection

Ordering Information

| PART | TEMP RANGE | PIN-PACKAGE |
|---------------------|-----------------|-------------|
| MAX14852GWE+ | -40°C to +105°C | 16 SOIC (W) |
| MAX14852GWE+T | -40°C to +105°C | 16 SOIC (W) |
| MAX14854GWE+ | -40°C to +105°C | 16 SOIC (W) |
| MAX14854GWE+T | -40°C to +105°C | 16 SOIC (W) |

+Denotes a lead(Pb)-free/RoHS-compliant package.
T = Tape and reel.

Package Information

For the latest package outline information and land patterns (footprints), go to www.maximintegrated.com/packages. Note that a "+", "#", or "-" in the package code indicates RoHS status only. Package drawings may show a different suffix character, but the drawing pertains to the package regardless of RoHS status.

| PACKAGE TYPE | PACKAGE CODE | OUTLINE NO. | LAND PATTERN NO. |
|--------------|--------------|-------------------------|-------------------------|
| 16 SOIC | W16M+9 | 21-0042 | 90-0107 |

Chip Information

PROCESS: BiCMOS

MAX14852/MAX14854

2.75kV_{RMS} Isolated 500kbps/25Mbps Full-Duplex
RS-485/RS-422 Transceivers
with ±35kV ESD Protection

Revision History

| REVISION NUMBER | REVISION DATE | DESCRIPTION | PAGES CHANGED |
|-----------------|---------------|----------------------------------|---------------|
| 0 | 11/15 | Initial release | — |
| 1 | 1/17 | Updated pending safety approvals | 1, 7 |

For pricing, delivery, and ordering information, please contact Maxim Direct at 1-888-629-4642, or visit Maxim Integrated's website at www.maximintegrated.com.

Maxim Integrated cannot assume responsibility for use of any circuitry other than circuitry entirely embodied in a Maxim Integrated product. No circuit patent licenses are implied. Maxim Integrated reserves the right to change the circuitry and specifications without notice at any time. The parametric values (min and max limits) shown in the Electrical Characteristics table are guaranteed. Other parametric values quoted in this data sheet are provided for guidance.

Looking for pricing, stock, or lifecycle information?

Click below to explore more details on WIN SOURCE:

 [View MAX14852GWE+ on WIN SOURCE](#)

 [Analog Devices Inc. Information](#)

Optimize Your Supply Chain with WIN SOURCE Solutions

-  Global Sourcing Solution
-  Obsolete Management
-  Cost Control Management
-  Shortage Management
-  Alternative Solution
-  Excess Inventory Management