



**THE DATASHEET OF
IQS572-BL-QNR**





IQS550/572/525-B000 DATASHEET

Projected capacitive trackpad/touchscreen controller with proximity, touch, snap, trackpad outputs and gestures.

The IQS5xx-B000 is a projected capacitive touch and proximity trackpad/touchscreen controller implementation on the IQS550, IQS572 and IQS525 platforms. The IQS5xx-B000 features best in class sensitivity, signal-to-noise ratio and automatic tuning of electrodes. Low power proximity detection allows extreme low power operation.

Main Features

- > Proximity, touch and snap* on each channel
- > Multi-touch support up to 5 fingers
- > Single and multi-finger gestures
- > 3584 x 2304 max resolution (IQS550)
- > Scale, orientation and electrode layout selection
- > I²C communication interface
- > ATI: automatic tuning for optimum sensitivity
- > Supply Voltage 1.65V to 3.6V
- > Proximity low power operation (<10uA)
- > 3 Active and 2 low power modes
- > Event and streaming modes
- > Internal voltage regulator and reference capacitor
- > On-chip noise detection and suppression

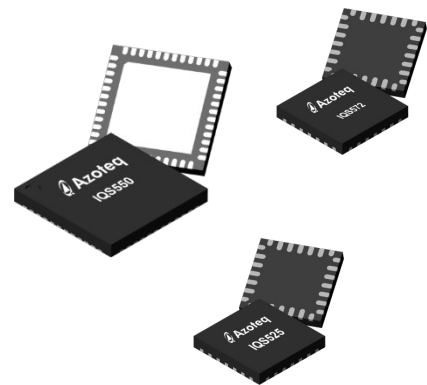

	IQS550	IQS572	IQS525
Maximum channels	150	72	25
Typical report rate (with single touch / all channels active)	100Hz	135Hz	190Hz
Maximum resolution (for shown Tx Rx configurations)	3584 x 2304 (15 x 10)	2048 x 1792 (9 x 8)	1280 x 768 (6 x 4)

Applications

- > Compact Capacitive Keyboards
- > Remote Control Trackpads
- > Appliances
- > Navigation devices
- > Kiosks and POS terminals
- > E-reader

T _A	QFN(7x7)-48	QFN(4x4)-28	QFN(4x4)-28
-40°C to 85°C	IQS550	IQS572	IQS525

*Patented



Contents

1	OVERVIEW	7
2	PACKAGING AND PIN-OUT	8
2.1	IQS550 - QFN48	8
2.2	IQS572 - QFN28	10
2.3	IQS525 - QFN28	12
3	PROXSENSE® MODULE	14
3.1	CHANNEL DEFINITION	14
3.2	ALTERNATE LOW-POWER CHANNEL (ALP)	14
3.3	COUNT VALUE	14
3.3.1	<i>Trackpad Count Values</i>	14
3.3.2	<i>ALP Count Values</i>	14
3.3.3	<i>Max Count</i>	15
3.3.4	<i>Delta Value</i>	15
3.4	REFERENCE VALUE	15
3.4.1	<i>Reference Update Time</i>	15
3.4.2	<i>ALP Long-Term Average</i>	15
3.4.3	<i>Reseed</i>	15
3.5	CHANNEL OUTPUTS	15
3.5.1	<i>Proximity</i>	16
3.5.2	<i>Touch</i>	16
3.5.3	<i>Snap</i>	16
3.5.4	<i>Output Debounce</i>	16
3.5.5	<i>Maximum Touch</i>	17
3.6	AUTO TUNING (ATI)	17
3.6.1	<i>ATI C Multiplier</i>	17
3.6.2	<i>ATI Compensation & Auto ATI</i>	17
3.7	AUTOMATIC RE-ATI	17
3.7.1	<i>Description</i>	17
3.7.2	<i>Conditions for Re-ATI to activate</i>	18
3.7.3	<i>ATI Error</i>	18
3.7.4	<i>Design requirements</i>	18
3.8	SENSING HARDWARE SETTINGS	19
4	SENSING MODES	19
4.1	REPORT RATE	20
4.1.1	<i>Previous Cycle Time</i>	20
4.2	MODE TIMEOUT	20
4.3	MANUAL CONTROL	20
5	TRACKPAD	20
5.1	CONFIGURATION	20
5.1.1	<i>Size Selection</i>	20
5.1.2	<i>Individual Channel Disabling</i>	20
5.1.3	<i>Rx / Tx Mapping</i>	20
5.1.4	<i>Rx / Tx Selections</i>	21
5.2	TRACKPAD OUTPUTS	21
5.2.1	<i>Number of Fingers</i>	21
5.2.2	<i>Relative XY</i>	21
5.2.3	<i>Absolute XY</i>	21



5.2.4	Touch Strength	21
5.2.5	Area	21
5.2.6	Tracking / Identification	21
5.3	MAX NUMBER OF MULTI-TOUCHES	21
5.4	XY RESOLUTION	22
5.5	PALM REJECTION	22
5.6	STATIONARY TOUCH	22
5.7	MULTI-TOUCH FINGER SPLIT	22
5.8	XY OUTPUT FLIP & SWITCH	22
5.9	XY POSITION FILTERING	22
5.9.1	MAV Filter	22
5.9.2	IIR Filter	22
6	GESTURES	23
6.1	SINGLE TAP	23
6.2	PRESS AND HOLD	24
6.3	SWIPE (X-, X+, Y-, Y+)	24
6.4	TWO FINGER TAP	24
6.5	SCROLL	25
6.6	ZOOM	25
6.7	SWITCHING BETWEEN GESTURES	25
7	ADDITIONAL FEATURES	25
7.1	NON-VOLATILE DEFAULTS	25
7.2	AUTOMATED START-UP	26
7.3	SUSPEND	26
7.3.1	I ² C Wake	26
7.3.2	Switch Input Pin Wake	26
7.4	RESET	26
7.4.1	Reset Indication	26
7.4.2	Software Reset	26
7.4.3	Hardware Reset	26
7.5	WATCHDOG TIMER (WDT)	26
7.6	RF IMMUNITY	26
7.7	ADDITIONAL NON-TRACKPAD CHANNELS	27
7.8	BOOTLOADER	27
7.8.1	Bootloader Status	27
7.9	VERSION INFORMATION	27
7.9.1	Product Number	27
7.9.2	Project Number	27
7.9.3	Major and Minor Versions	27
7.10	UNIQUE ID	27
7.11	SWITCH INPUT	27
8	I²C	27
8.1	DATA READY (RDY)	27
8.2	SLAVE ADDRESS	28
8.3	16-BIT ADDRESSING	28
8.4	I ² C READ	28
8.4.1	Default Read Address	28
8.5	I ² C WRITE	28



8.6	I ² C TIMEOUT	28
8.7	END OF COMMUNICATION SESSION / WINDOW	28
8.8	EVENT MODE COMMUNICATION	28
8.8.1	<i>Events</i>	29
8.8.2	<i>Force Communication</i>	29
8.9	MEMORY MAP REGISTERS	30
8.10	MEMORY MAP BIT / REGISTER DEFINITIONS	36
8.10.1	<i>Gesture Events 0</i>	36
8.10.2	<i>Gesture Events 1</i>	37
8.10.3	<i>System Info 0</i>	37
8.10.4	<i>System Info 1</i>	38
8.10.5	<i>Individual Channel Status / Config Bit Definitions</i>	39
8.10.6	<i>Count / Delta / Reference Data</i>	40
8.10.7	<i>System Control 0</i>	40
8.10.8	<i>System Control 1</i>	41
8.10.9	<i>System Config 0</i>	41
8.10.10	<i>System Config 1</i>	42
8.10.11	<i>Filter Settings 0</i>	42
8.10.12	<i>Alternate Channel Setup</i>	43
8.10.13	<i>ALP Rx select</i>	43
8.10.14	<i>ALP Tx select</i>	43
8.10.15	<i>RxToTx</i>	44
8.10.16	<i>Hardware Settings A</i>	44
8.10.17	<i>Hardware Settings B</i>	44
8.10.18	<i>Hardware Settings C</i>	45
8.10.19	<i>Hardware Settings D</i>	45
8.10.20	<i>XY Config 0</i>	46
8.10.21	<i>Single Finger Gestures</i>	46
8.10.22	<i>Multi-finger Gestures</i>	47
9	CIRCUIT DIAGRAM	47
10	ELECTRICAL CHARACTERISTICS	52
10.1	ABSOLUTE MAXIMUM RATINGS	52
10.2	OPERATING CONDITIONS	53
10.2.1	<i>General Operating Conditions</i>	53
10.2.2	<i>Power-up / Power-down Operating Conditions</i>	53
10.2.3	<i>Supply Current Characteristic</i>	54
10.2.4	<i>ProxSense® Current Consumption</i>	54
10.2.5	<i>Expected Total Current Consumption Scenarios</i>	54
10.2.6	<i>I/O Port Pin Characteristics</i>	56
10.2.7	<i>Output Driving Current</i>	57
10.2.8	<i>NRST Pin</i>	57
10.2.9	<i>I²C Characteristics</i>	59
10.2.10	<i>Package Moisture Sensitivity</i>	60
10.2.11	<i>Electrostatic Discharge (ESD)</i>	60
10.2.12	<i>Thermal Characteristics</i>	60
10.2.13	<i>ProxSense Electrical Characteristics</i>	61
11	MECHANICAL DIMENSIONS	62
11.1	IQS550 QFN(7x7)-48 MECHANICAL DIMENSIONS	62
11.2	IQS550 LANDING PAD LAYOUT	63
11.3	IQS572/IQS525 QFN(4x4)-28 MECHANICAL DIMENSIONS	64
11.4	IQS572/IQS525 LANDING PAD LAYOUT	65



12	PACKAGING INFORMATION	66
12.1	TAPE SPECIFICATION	66
12.1.1	<i>IQS550 Tape Description</i>	67
12.1.2	<i>IQS572 and IQS525 Tape Description</i>	67
12.2	REEL SPECIFICATION	68
12.2.1	<i>Dry Packing</i>	69
12.2.2	<i>Baking</i>	69
12.3	HANDLING OF THE IQS5XX	70
12.4	REFLOW FOR IQS5XX	70
13	DEVICE MARKING	72
13.1	IQS550 MARKING	72
13.2	IQS572/IQS525 MARKING	73
14	ORDERING INFORMATION	74
14.1	IQS550 ORDERING	74
14.2	IQS572 ORDERING	74
14.3	IQS525 ORDERING	74
15	CHANGES:	75
16	CONTACT INFORMATION	76



List of Abbreviations

ALP	Alternate Low Power
ATI	Automatic Tuning Implementation
EMI	Electromagnetic Interference
ESD	Electrostatic Discharge
GND	Ground
GUI	Graphical User Interface
IC	Integrated Circuit
ICI	Internal Capacitor Implementation
IIR	Infinite Impulse Response
LP	Low Power
LTA	Long Term Average
MAV	Moving Average
ND	Noise Detect
THR	Threshold
TP	Trackpad
WDT	Watchdog Timer



1 Overview

The IQS550 / IQS572 / IQS525 are capacitive sensing controllers designed for multi-touch applications using projected capacitance touch panels. The device offers high sensitivity proximity wake-up and contact detection (touch) through a selectable number of sensor lines (Rxs and TxS).

The device has an internal voltage regulator and Internal Capacitor Implementation (ICI) to reduce external components. Advanced on-chip signal processing capabilities provide stable high performance with high sensitivity.

A trackpad consists of an array of sensors that are scanned at regular intervals. The controller uses the principle of projected capacitance charge transfer on the trackpad. When a conductive object such as a human finger approaches the sense plate it will decrease the detected capacitance. Thresholds are applied to the sensor data to identify areas that exhibit proximity and touch deviation. The contours of the touch areas are then translated to Cartesian position coordinates that are continuously monitored to identify gestures. A user has access to all of the data layers – the raw sensor data, the sensor proximity/touch status data, the XY coordinates as well as the gesture outputs.

Multiple filters are implemented to detect and suppress noise, track slow varying environmental conditions and avoid effects of possible drift. The Auto Tuning (ATI) allows for the adaptation to a wide range of touch screens without using external components.

An innovative addition, known as a snap*, is also available on each channel. This adds another channel output, additional to the proximity and touch.

The trackpad application firmware on the IQS5xx is very flexible in design, and can incorporate standard touch sensors, trackpad / touchscreen areas (giving XY output data) and conventional snap-dome type buttons, all providing numerous outputs such as proximity, touch, snap, touch strength, area and actual finger position all in one solution.

The IQS550, IQS572 and IQS525 devices ship with the bootloader only, since the designer must program custom IQS5xx-B000 firmware during production testing. The custom firmware is the IQS5xx-B000 trackpad firmware together with customer specific hardware settings exported by the GUI program.



*This datasheet applies to the following **IQS550** version:
Product Number 40 / Project Number 15 / Version Number 2*



*This datasheet applies to the following **IQS572** version:
Product Number 58 / Project Number 15 / Version Number 2*



*This datasheet applies to the following **IQS525** version:
Product Number 52 / Project Number 15 / Version Number 2*



*Patented



2 Packaging and Pin-out

2.1 IQS550 - QFN48

The IQS550 is available in a QFN(7x7)-48 package.

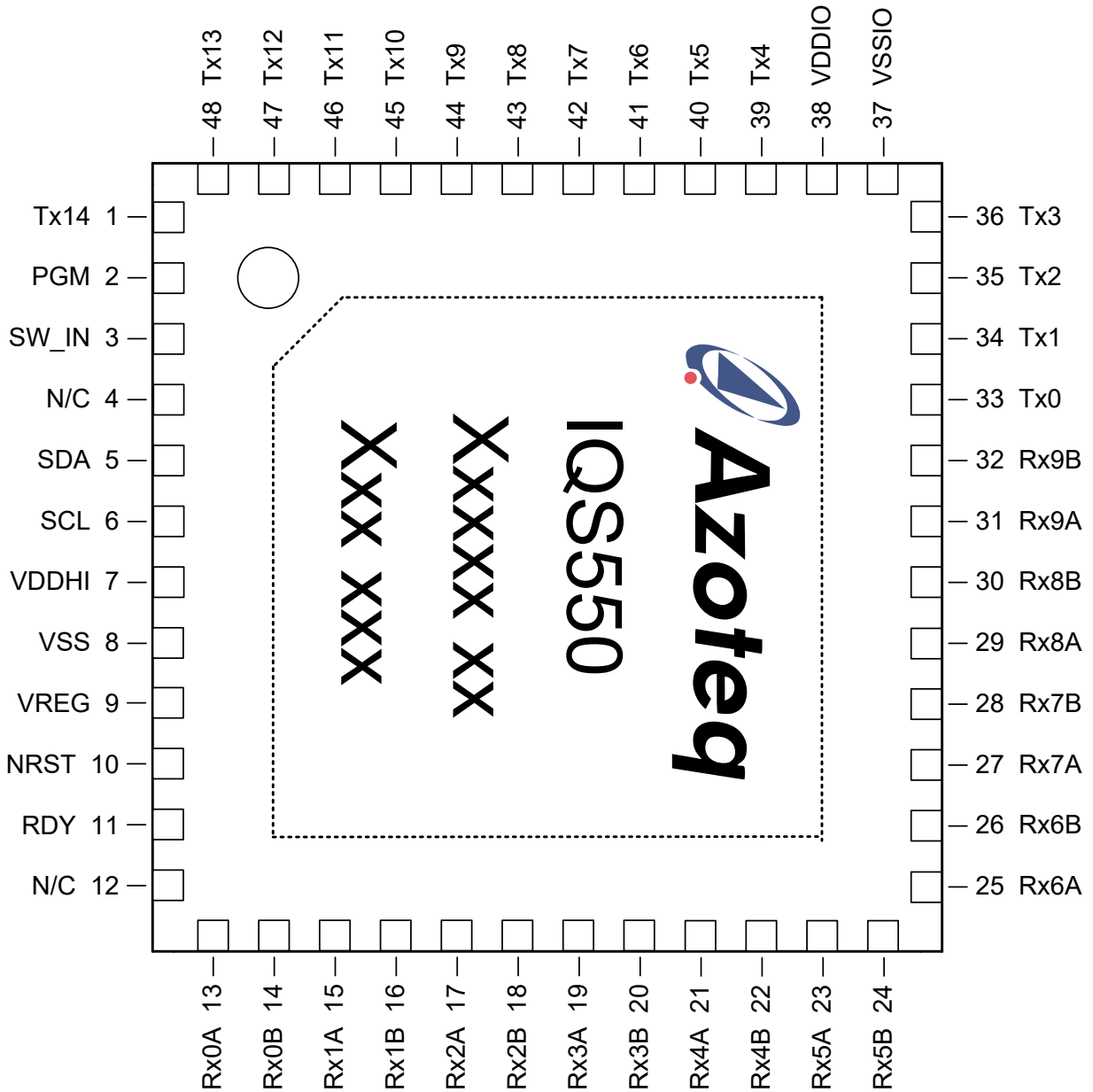

Figure 2.1 QFN Top View



Table 2.1 QFN48 Pin-out

Pin	Name	Description	Pin	Name	Description
1	Tx14	Transmitter electrode	25	Rx6A	Receiver electrode
2	PGM	Programming Pin	26	Rx6B	Note1
3	SW_IN	Wake-up from suspend and switch input	27	Rx7A	Receiver electrode
4	n/c	~	28	Rx7B	Note1
5	SDA	I2C Data	29	Rx8A	Receiver electrode
6	SCL	I2C Clock	30	Rx8B	Note1
7	VDDHI	Supply Voltage	31	Rx9A	Receiver electrode
8	VSS	Ground Reference	32	Rx9B	Note1
9	VREG	Internal Regulator Voltage	33	Tx0	Transmitter electrode
10	NRST	Reset (active LOW)	34	Tx1	Transmitter electrode
11	RDY	I2C RDY	35	Tx2	Transmitter electrode
12	n/c	~	36	Tx3	Transmitter electrode
13	Rx0A	Receiver electrode	37	VSSIO	I/O Ground Reference
14	Rx0B	Note1	38	VDDIO	I/O Supply Voltage
15	Rx1A	Receiver electrode	39	Tx4	Transmitter electrode
16	Rx1B	Note1	40	Tx5	Transmitter electrode
17	Rx2A	Receiver electrode	41	Tx6	Transmitter electrode
18	Rx2B	Note1	42	Tx7	Transmitter electrode
19	Rx3A	Receiver electrode	43	Tx8	Transmitter electrode
20	Rx3B	Note1	44	Tx9	Transmitter electrode
21	Rx4A	Receiver electrode	45	Tx10	Transmitter electrode
22	Rx4B	Note1	46	Tx11	Transmitter electrode
23	Rx5A	Receiver electrode	47	Tx12	Transmitter electrode
24	Rx5B	Note1	48	Tx13	Transmitter electrode

Note1: Any of these can be configured through I²C as the ProxSense® electrode.



2.2 IQS572 - QFN28

The IQS572 is available in a QFN(4x4)-28 package. The production version is shown below.

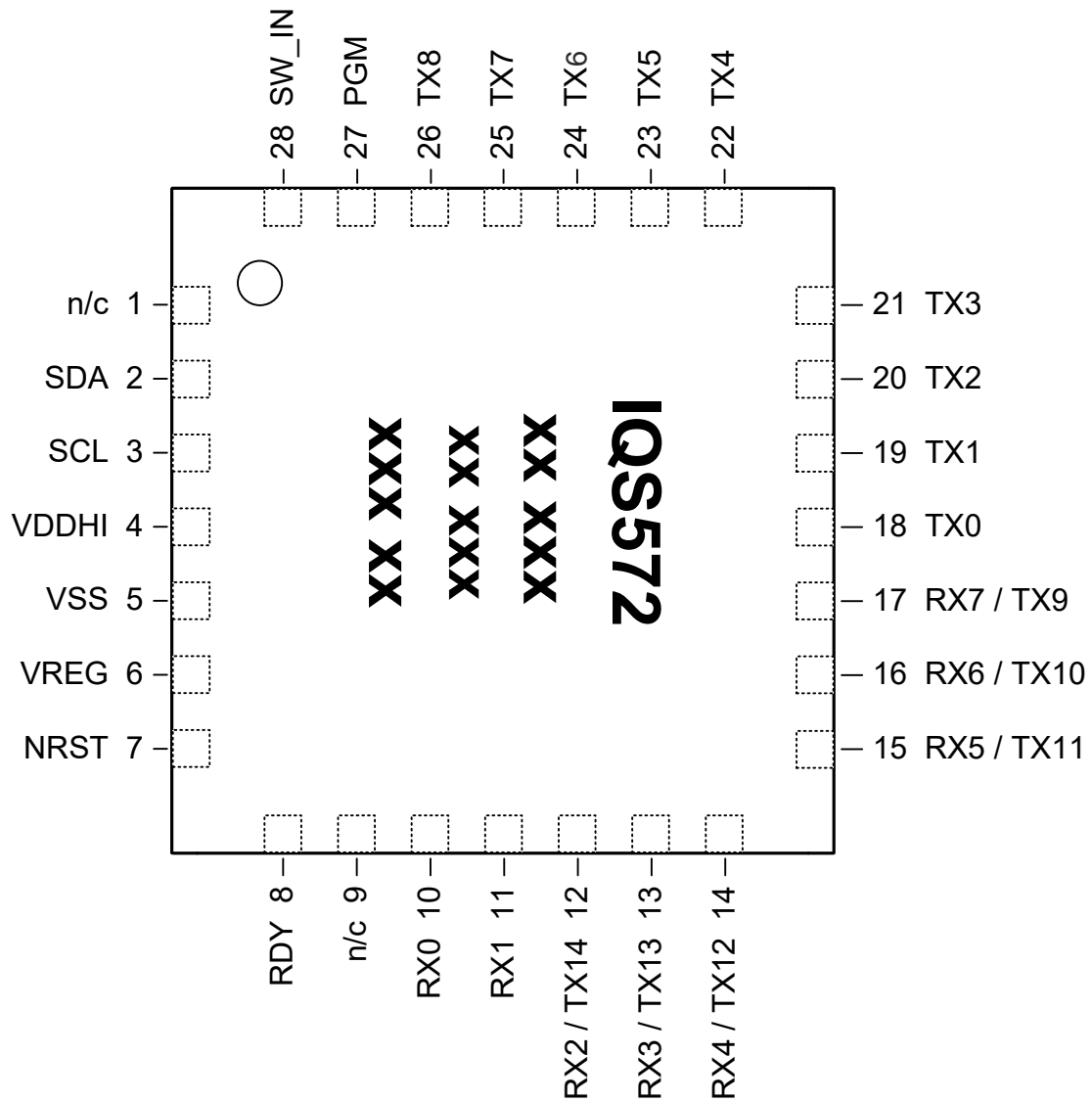

Figure 2.2 IQS572 QFN Top View



Table 2.2 IQS572 QFN28 Pin-out

Pin	Name	Description	Pin	Name	Description
1	n/c	~	15	Rx5	Receiver electrode
2	SDA	I ² C Data	16	Rx6	Receiver electrode
3	SCL	I ² C Clock	17	Rx7	Receiver electrode
4	VDDHI	Supply Voltage	18	Tx0	Transmitter electrode
5	VSS	Ground Reference	19	Tx1	Transmitter electrode
6	VREG	Internal Regulator Voltage	20	Tx2	Transmitter electrode
7	NRST	Reset (active LOW)	21	Tx3	Transmitter electrode
8	RDY	I ² C RDY	22	Tx4	Transmitter electrode
9	n/c	~	23	Tx5	Transmitter electrode
10	Rx0	Receiver electrode	24	Tx6	Transmitter electrode
11	Rx1	Receiver electrode	25	Tx7	Transmitter electrode
12	Rx2	Receiver electrode	26	Tx8	Transmitter electrode
13	Rx3	Receiver electrode	27	PGM	Programming Pin
14	Rx4	Receiver electrode	28	SW_IN	Wake-up from suspend and switch input



2.3 IQS525 - QFN28

The IQS525 is available in a QFN(4x4)-28 package. The production version is shown below.

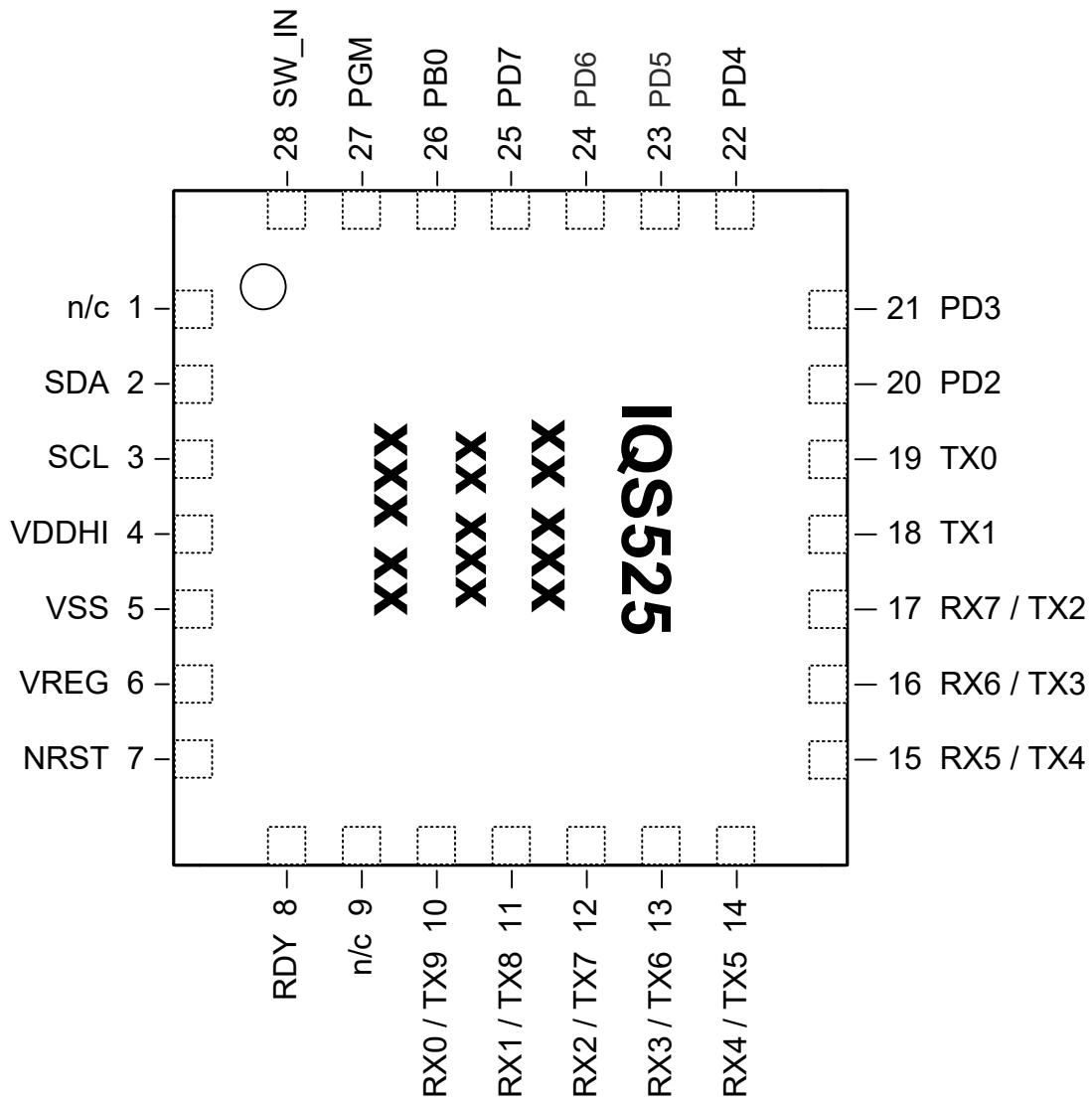

Figure 2.3 IQS525 QFN Top View



Table 2.3 QFN28 Pin-out

Pin	Name	Description	Pin	Name	Description
1	n/c	~	15	Rx5 / TX4	Receiver / Transmitter electrode
2	SDA	I ² C Data	16	Rx6 / TX3	Receiver / Transmitter electrode
3	SCL	I ² C Clock	17	Rx7 / TX2	Receiver / Transmitter electrode
4	VDDHI	Supply Voltage	18	Tx1	Transmitter electrode
5	VSS	Ground Reference	19	Tx0	Transmitter electrode
6	VREG	Internal Regulator Voltage	20	PD2	General purpose I/O
7	NRST	Reset (active LOW)	21	PD3	General purpose I/O
8	RDY	I ² C RDY	22	PD4	General purpose I/O
9	n/c	~	23	PD5	General purpose I/O
10	Rx0	Receiver electrode	24	PD6	General purpose I/O
11	Rx1	Receiver electrode	25	PD7	General purpose I/O
12	Rx2	Receiver electrode	26	PB0	General purpose I/O
13	Rx3	Receiver electrode	27	PGM	Programming Pin
14	Rx4	Receiver electrode	28	SW_IN	Wake-up from suspend and switch input



3 ProxSense® Module

The IQS5xx contains a ProxSense® module that uses patented technology to measure and process the capacitive sensor data. The trackpad sensors are scanned one Tx transmitter at a time, until all have completed, with all enabled Rxs charging in each Tx time slot. The channel outputs (proximity, touch and snap) are the primary outputs from the sensors. These are processed further to provide secondary trackpad outputs that include finger position, finger size as well as on-chip gesture recognition.

The additional snap state is a unique sensor output that utilises capacitive technology to sense the depression of a metal dome snap button onto the customized sensor area. This gives an additional output above the traditional proximity and touch channel outputs.

For more information on capacitive sensing and charge transfers, please refer to the Azoteq Application Note AZD004.

For more information regarding design guidelines refer to the Application Note AZD068.

3.1 Channel Definition

A channel for a projected capacitive sensor consists of a Tx electrode that is in close proximity to an Rx electrode.

On a trackpad sensor (typically a diamond shape pattern), each intersection of an Rx and Tx row/column forms a capacitive sensing element which is referred to as a *channel*. Each channel has an associated count value, reference value, proximity, touch and snap (if enabled) status. The maximum number of Tx and Rx electrodes on the IQS550 device is 15x10, thus giving 150 channels in total.

3.2 Alternate Low-Power Channel (ALP)

If lower power consumption is required (*ALP*), LP1 and LP2 can be configured to utilise a single custom channel sensor, instead of sensing the trackpad channels. This channel has a lot of setup flexibility:

- > Sensing method (*CHARGE_TYPE*): projected capacitive or self capacitive.
- > Sensors: which Rxs (*RX_GROUP* / *ALP Rx select*) / Txs (*ALP Tx select*) are active during conversions.
- > Reverse sensing: If enabled, negative deviations can also trigger proximity detection (*PROX_REVERSE*).
- > Count value filtering: gives reliable proximity detection in noisy environments.
- > Single channel: since the alternate channel is processed as only a single channel, much less processing is done, allowing for lower overall power consumption.

Since all Rxs return a count measurement, it means that the ALP channel can be a combination of numerous measurements. To reduce processing time (and this decrease current consumption) the measurements are added together and processed as a single 'channel'.

3.3 Count Value

The capacitive sensing measurement returns a *count value* for each channel. Count values are inversely proportional to capacitance, and all outputs are derived from this them.

3.3.1 Trackpad Count Values

The individual trackpad channel count values (*Count values*) are unfiltered.

3.3.2 ALP Count Values

The combined count value (*ALP count value*) used for this channel is a summation of the individual count values (*ALP individual count values*) from each active Rx.

A count value filter is implemented on this channel to give stable proximity output for system wake-up from a low-power mode. It is recommended to leave this count filter enabled (*ALP_COUNT_FILTER*).

The amount of filtering can be modified (*ALP count beta*) if required. This beta is used as follows to determine the damping factor of the filter:



Count damping factor = Beta / 256

If the beta is small, the filtering is stronger, and if the beta is larger, the filtering is weaker.

3.3.3 Max Count

Each channel is limited to having a count value smaller than the configurable limit (Max count limit). If the ATI setting or hardware causes measured count values higher than this, the conversion will be stopped, and a value of '0' will be read for that relevant count value. Note that a '0' is also returned for a disabled channel.

3.3.4 Delta Value

The delta values (Delta values) are simply:

$$\text{Delta} = \text{Count} - \text{Reference}$$

3.4 Reference Value

User interaction is detected by comparing count values to reference values. The count value of a sensor represents the instantaneous capacitance of the sensor. The reference value of a sensor is the count value of the sensor that is slowly updated to track changes in the environment, and is not updated during user interaction.

The reference value is a two-cycle averaged of the count value, stored during a time of no user activity, and thus is a non-affected reference. The trackpad reference values are only updated from LP1 and LP2 mode when modes are managed automatically. Thus, if the system is controlled manually, the reference must also be managed and updated manually by the host.

3.4.1 Reference Update Time

The reference value is updated or refreshed according to a configurable interval (Reference update time), in seconds.

To ensure that the reference value is not updated during user interaction, it only executes from the LP1 and LP2 states, where no user interaction is assumed.

Setting the Reference update time to '0' will disable the updating of the reference values.

3.4.2 ALP Long-Term Average

The ALP channel does not have a snapshot reference value as used on the trackpad, but utilises a filtered long-term average value (ALP LTA value). The LTA tracks the environment closely for accurate comparisons to the measured count value, to allow for small proximity deviations to be sensed. The speed of LTA tracking can be adjusted with the ALP LTA beta. There is an ALP1 and ALP2, which are implemented in LP1 and LP2 respectively. This is to allow different settings for different report rates, so that the LTA tracking rate can remain the same.

3.4.3 Reseed

Since the *Reference* (or *LTA* for ALP channel) is critical for the device to operate correctly, there could be known events or situations which would call for a manual reseed. A reseed takes the latest measured counts, and seeds the *reference/LTA* with this value, therefore updating the value to the latest environment. A reseed command can be given by setting the corresponding bit (RESEED or ALP_RESEED).

3.5 Channel Outputs

For the trackpad channels, user interaction typically causes the count values to increase. The amount of deviation relative to the reference can be used to determine the output state of the channel, dependent on the sensitivities configured.

For a snap actuation, the count values decrease, and a negative deviation cause a snap output.

If the measured count value exceeds the selected threshold value for consecutive cycles, equal in number to the selectable debounce parameter, the output becomes set.



3.5.1 Proximity

This output (Prox status) is set when a channels' count value deviates from the reference value by more than the selected threshold (Prox threshold).

The proximity threshold is the smallest difference between the count value and the reference value that would result in a proximity output. Small threshold values are thus more sensitive than large threshold values.

Note: For the trackpad channels (projected capacitive) the samples will increase with user interaction, thus the actual threshold is the reference value PLUS the threshold parameter.

However, if an ALP channel is implemented in self capacitive mode, the samples will decrease during user interaction, thus the actual threshold is the reference value MINUS the threshold parameter.

3.5.2 Touch

This output (Touch status) is set when a channels' count value increases by more than the selected threshold.

The touch threshold for a specific channel is calculated as follows:

$$\text{Threshold} = \text{Reference} \times (1 + \text{Multiplier} / 128)$$

A smaller fraction will thus be a more sensitive threshold.

A trackpad will have optimal XY data if all of the channels in the trackpad exhibit similar deltas under similar user inputs. In such a case all of the channels will have identical thresholds. In practise, sensor design and hardware restrictions could cause deltas which are not constant over the entire trackpad. It could then be required to select individual multiplier values. These (Individual touch multiplier adjustment) are signed 8-bit values and indicate how much the unsigned 8-bit global value (Global touch multiplier) must be adjusted. The threshold used for a specific channel (set and clear) is as follows:

$$\text{Multiplier} = \text{Global} + \text{Individual adjust}$$

A hysteresis can also be implemented because there are different touch multiplier parameters

for setting a touch and clearing a touch. This hysteresis allows the channels to not flicker in and out of touch with noise.

3.5.3 Snap

When adding a metal snap-dome overlay to the trackpad pattern, an additional *snap* output (Snap status) is available. The device is able to distinguish between a normal 'touch' on the overlay and an actual button 'snap', which depresses the metal dome onto the Rx/Tx pattern. The design must be configured so that a snap on the metal dome will result in a channels' count value falling well below the reference for that channel.

If required, the function must be enabled (Snap enabled channels) for each channel on which snap is designed. *Only channels with snap must be marked as such, since channels are handled differently if they are snap channels, compared to non-snap channels.*

One global snap threshold (Snap threshold) is implemented as a delta value BELOW the reference. When a snap is performed, a sensor saturation effect causes the deviation to be negative.

Because it is only necessary to read the individual snap registers if a state change has occurred, a status bit (SNAP TOGGLE) is added to indicate this. This is only set when there is a change of status of any snap channel.

A reseed is executed if a snap is sensed for longer than the Snap timeout time (in seconds). A setting of 0 will never reseed. The timeout is reset if any snap is set or cleared.

3.5.4 Output Debounce

All the channel outputs (proximity, touch and snap) are debounced according to the selectable debounce values (Prox debounce / Touch snap debounce). Note that a debounce value of 1 means that two samples satisfying the condition must be met consecutively before the output is activated. The default *touch debounce* is set to 0 / no debouncing. This is due to the fact that with a 15x10 sensor,



debouncing adds too much delay, and fast movements on the touch panel cannot be debounced fast enough to provide reliable XY output data.

3.5.5 Maximum Touch

An additional output is provided (*Max Touch*) and indicates the column and row of the channel with the largest touch deviation. This is usually only utilised when implementing discrete buttons, to reject any adjacent keys if they are located in close proximity to each other. If the Rxs and TxS are switched (*SWITCH XY AXIS*), the columns are the TxS, and the rows are the Rxs. If no touches are seen, then this will output 0xFF.

3.6 Auto Tuning (ATI)

The ATI is a sophisticated technology implemented in the new ProxSense® devices to allow optimal performance of the devices for a wide range of sensing electrode capacitances, without modification to external components. The ATI settings allow tuning of two parameters, ATI C Multiplier and ATI Compensation, to adjust the sample value for an attached sensing electrode.

For detailed information regarding the on-chip ATI technology, please refer to AZD027 and AZD061.

The main advantage of the ATI is to balance out small variations between trackpad hardware and IQS5xx variation, to give similar performance across devices.

3.6.1 ATI C Multiplier

All trackpad channels can be adjusted globally by modifying the global parameter (*Global ATI C*).

Although it is recommended to keep the same ATI C value for all trackpad channels, if different values are required (possibly for different trackpads), individual adjustments can be made. The ATI C value for each channel can be adjusted using 8-bit signed values (*ATI C individual adjust*) as follows:

$$\text{ATI C} = \text{Global} + \text{Individual Adjust}$$

The ALP channel has its own global ATI C parameter (*ALP ATI C*).

3.6.2 ATI Compensation & Auto ATI

The ATI Compensation value for each channel (*ATI compensation*) is set by means of an automated ATI procedure. The algorithm is executed after the *AUTO ATI* bit is set. The ATI Compensation values are chosen so that each count value is close to the selected target value (*ATI target / ALP ATI target*).

The *AUTO ATI* bit clears automatically on chip when the algorithm has completed.

The ATI routine will run for the channels of the current mode, for example, if the system is currently sensing the *alternate low-power* channel, the auto ATI will apply to it, similarly the algorithm will configure the trackpad channels if they are currently active.

The ALP channel has individual compensation values (*ALP ATI compensation*) for each enabled Rx.

The ALP ATI target value applies to each of the individual count values configured for the ALP channel.

This routine will only execute after the communication window is terminated, and the I2C communication will only resume again once the ATI routine has completed.

3.7 Automatic Re-ATI

3.7.1 Description

When enabled (*REATI* or *ALP REATI*) the ATI algorithm will be repeated if certain conditions are met. One of the most important features of the Re-ATI is that it allows easy and fast recovery from an incorrect ATI, such as when performing ATI during user interaction with the sensor. This could cause the wrong ATI Compensation to be configured, since the user affects the capacitance of the sensor. A Re-ATI would correct this.

When a Re-ATI is performed on the IQS5xx, a status bit will set momentarily to indicate that



this has occurred (REATI_OCCURRED / ALP_REATI_OCCURRED).

3.7.2 Conditions for Re-ATI to activate

1. Reference drift

A Re-ATI is performed when the reference of a channel drifts outside of the acceptable range around the ATI Target.

The boundaries where Re-ATI occurs for the trackpad channels and for the ALP channels are independently set via the drift threshold value (Reference drift limit / ALP LTA drift limit). The Re-ATI boundaries are calculated from the delta value as follows:

$$\text{Re-ATI Boundary} = \text{ATI target} \pm \text{Drift limit}$$

For example, assume that the ATI target is configured to 800 and that the reference drift value is set to 50. If Re-ATI is enabled, the ATI algorithm will be repeated under the following conditions:

$$\text{Reference} > 850 \text{ or } \text{Reference} < 750$$

The ATI algorithm executes in a short time, so goes unnoticed by the user.

2. Very large count values

The configurable Max count limit is used to sense for unexpectedly large count values. A Re-ATI is triggered if the max count limit is exceeded for 15 consecutive cycles.

This limit is configured to be a value higher than the maximum count possible through user interaction, plus worst-case noise on the count value, plus headroom. The monitoring of this assists in correcting for a Re-ATI which occurred during a snap press. If this does occur, after removing the snap, the counts are typically very high. If this was not monitored a stuck touch could occur.

3. Decreased count value

A considerable decrease in the count value of a non-snap channel is abnormal, since user interaction increases the count value. Therefore if a decrease larger than the configurable threshold (Minimum count Re-ATI

delta) is seen on such a channel, it is closely monitored. If this is continuously seen for 15 cycles, it will trigger a Re-ATI. If the channel is a snap channel, this decrease is allowed since snap does cause count values to decrease.

3.7.3 ATI Error

After the ATI algorithm is performed, a check is done to see if there was any error with the algorithm. An ATI error is reported if one of the following is true for any channel after the ATI has completed:

- > ATI Compensation \leq ReATI lower compensation limit
- > ATI Compensation \geq ReATI upper compensation limit
- > Count is already outside the Re-ATI range upon completion of the ATI algorithm.

If any of these conditions are met, the corresponding error flag will be set (ATI_ERROR / ALP ATI_ERROR). The flag status is only updated again when a new ATI algorithm is performed.

Re-ATI will not be repeated immediately if an ATI Error occurs. A configurable time (Re-ATI retry time) will pass where the Re-ATI is momentarily suppressed. This is to prevent the Re-ATI repeating indefinitely. An ATI error should however not occur under normal circumstances.

3.7.4 Design requirements

The Re-ATI can be very useful when ATI parameters are selected for which successful Re-ATI operation can be expected. With the conditions for Re-ATI mentioned above, it is clear that when the designer sets the ATI parameters, it is beneficial to select the ATI C and ATI Target so that the resulting ATI Compensation values are near the centre of the range. This ensures that with changing sensitivity, the ATI Compensation has the ability to increase/decrease in value without it easily becoming 0 or 255. In general, ATI Compensation values between 100 and 150 are desirable as they provide ample room for adjustment. Note that the range is dependent on the sensitivity requirements, and on the capacitance of the sensor.



3.8 Sensing Hardware Settings

Settings specific to the ProxSense® Module charge transfer characteristics can be changed.

The charge transfer frequency (f_{cc}) can be calculated as:

$$f_{cc} = \frac{16.10^6}{(2^{(7-CK_FREQ)} \times (2 + UP + PASS + INC_PHASE))} \text{ [Hz]}$$

where

$$UP = 2^{(UPLEN-2)} \quad (\text{if } UPLEN > 4)$$

$$UP = UPLEN \quad (\text{if } UPLEN \leq 4)$$

$$PASS = 2^{(PASSLEN-2)} \quad (\text{if } PASSLEN > 4)$$

$$PASS = PASSLEN \quad (\text{if } PASSLEN \leq 4)$$

Note: CK_FREQ , $UPLEN$ and $PASSLEN$ are the numerical values of the settings.

For example, the default frequency is:

$$f_{cc} = \frac{16.10^6}{(2^{(7-7)} \times (2 + 4 + 3 + 0))} = 1.77\text{MHz}$$

The other hardware parameters are not discussed as they should only be adjusted under guidance of Azoteq support engineers.

4 Sensing Modes

The IQS5xx automatically switches between different charging modes dependent on user interaction and other aspects. This is to allow for fast response, and also low power consumption when applicable. The current mode can be read from the device (**CHARGING MODE**).

The modes are best illustrated by means of the following state diagram.

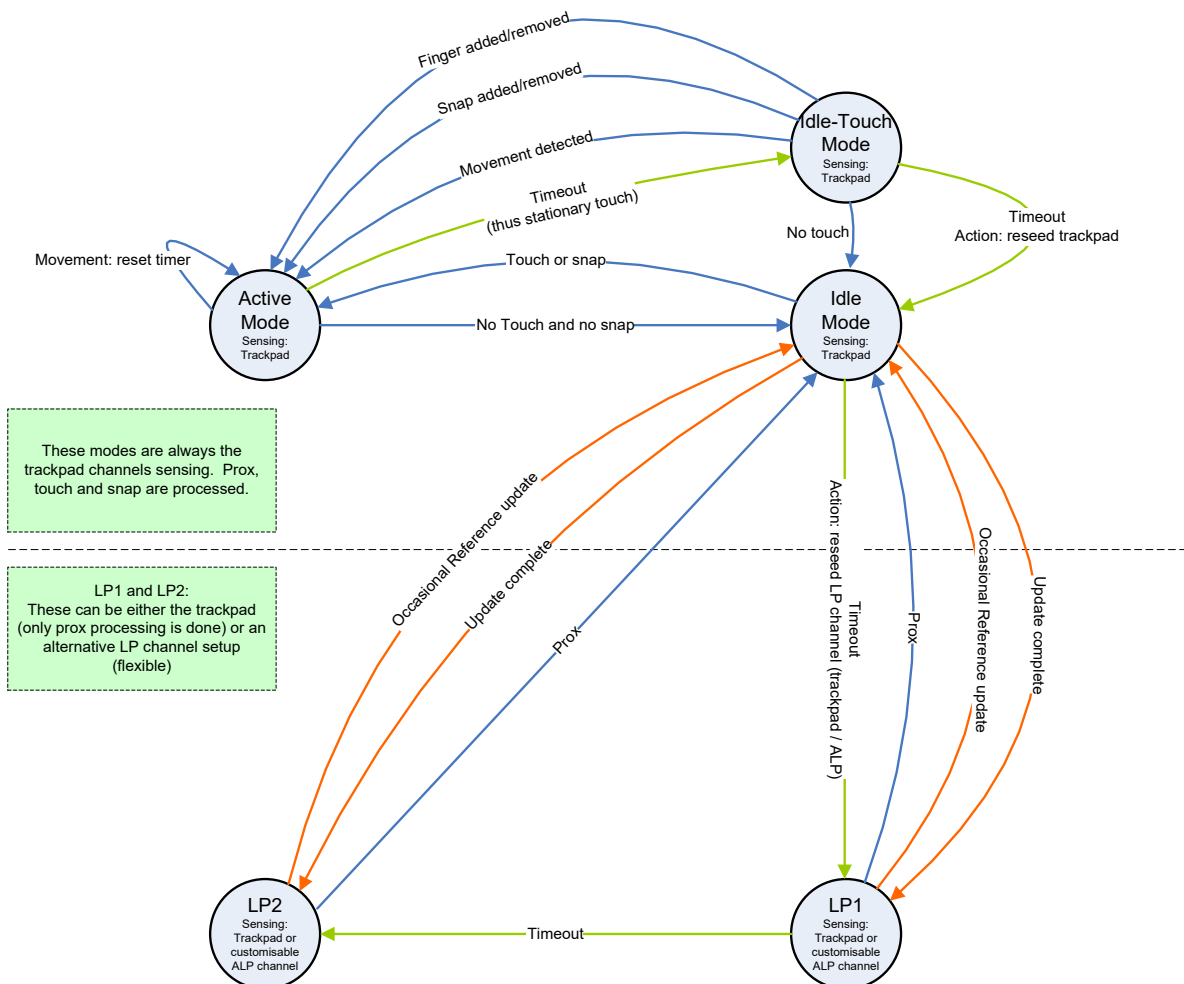

Figure 4.1 System Mode State Diagram



4.1 Report Rate

The report rate for each mode can be adjusted as required by the design. A faster report rate will have a higher current consumption but will give faster response to user interaction. *Active mode* typically has the fastest report rate, and the other modes are configured according to the power budget of the design, and the expected response time.

The report rate is configured by selecting the cycle time (in milliseconds) for each mode:

- > [Report rate Active mode](#)
- > [Report rate Idle touch mode](#)
- > [Report rate Idle mode](#)
- > [Report rate LP1 mode](#)
- > [Report rate LP2 mode](#)

4.1.1 Previous Cycle Time

The achieved report rate can be read ([Previous cycle time](#)) from the device each cycle; this is the previous cycles' length in milliseconds. If the desired rate is not achievable, that is, if processing and sensing takes longer than the specified time, a status flag ([RR MISSED](#)) indicates that the rate could not be achieved.

4.2 Mode Timeout

The timeout values can be configured, and once these times have elapsed, the system will change to the next state according to the state diagram.

These times are adjusted by selecting a desired value (in seconds), for the specific timeout:

- > [Timeout - Active mode](#)
- > [Timeout - Idle touch mode](#)
- > [Timeout - Idle mode](#)
- > [Timeout - LP1 mode](#)

Note: the timeout for LP1 is set in multiples of 20s (thus a setting of '30' translates to 600s, or 10min).

A timeout value of 255 will result in a 'never' timeout condition.

4.3 Manual Control

The default method allows the IQS5xx to automatically switch between modes and update reference values as shown in Figure 4.1. This requires no interaction from the master to manage the IQS5xx.

The master can manage various states and implement custom power modes when *Manual Control* is enabled ([MANUAL CONTROL](#)). The master needs to control the mode ([MODE SELECT](#)), and also manage the reference values by reseeding ([RESEED](#)) or manually writing to the reference registers ([Reference values](#)).

5 Trackpad

5.1 Configuration

5.1.1 Size Selection

The total number of Rx and Tx channels used for trackpad purposes must be configured ([Total Rx / Total Tx](#)). This gives a rectangular area of channels, formed by rows and columns of Rx and Tx sensors.

5.1.2 Individual Channel Disabling

If the sensor is not a completed rectangle (this could be due to board cut-outs or trackpad shape), channels not implemented but falling within the [Total Rx / Total Tx](#) rectangle, must be individually disabled ([Active channels](#)).

5.1.3 Rx / Tx Mapping

The Rxs and Txs of the trackpad can be assigned to the trackpad in any order to simplify PCB layout and design. Rxs and Txs can however not be interchanged (for example you cannot use both Rxs and Txs for the columns of the trackpad).

For both the mapping registers ([Rx mapping / Tx mapping](#)) the first byte relates to the mapping of the first row/column, the next byte in the memory map is the next row/column, and so on.



Example: If a 5x5 trackpad was to be designed with Rx/Tx mapping to columns and rows as shown in Table 5.1, the Rx and Tx mapping registers would need to be set as follows:

Rx Mapping = {3, 0, 8, 1, 2}

Tx Mapping = {0, 1, 13, 12, 11}

Each value shown here is a byte in the memory map. The rest of the mapping bytes are 'don't care' since they are not used.

Table 5.1 Mapping Example

Row number (mapped Tx)	Column number (mapped Rx)				
	0 (Rx3)	1 (Rx0)	2 (Rx8)	3 (Rx1)	4 (Rx2)
0 (Tx0)	5x5 Trackpad				
1 (Tx1)					
2 (Tx13)					
3 (Tx12)					
4 (Tx11)					

5.1.4 Rx / Tx Selections

On the IQS525 and IQS572, some Rxs can be configured to take on Tx functionality. The preferred option is to keep them as Rxs, but if more Tx's are needed in the design, they can be configured as such in the RxToTx register. This allows for elongated trackpads or sliders to be implemented on the two devices. The corresponding Rx or Tx number is then used in the mapping registers to configure the order of the electrodes.

5.2 Trackpad Outputs

The channel count variation (deltas) and touch status outputs are used to calculate finger location data.

5.2.1 Number of Fingers

This gives an indication of the number of active finger inputs on the trackpad (Number of fingers).

5.2.2 Relative XY

If there is only one finger active, a Relative X and Relative Y value is available. This is a signed 2's complement 16-bit value. It is a delta of the change in X and Y, in the scale of the selected output resolution.

Note: Gestures also use these registers to indicate swipe, scroll and zoom parameters.

5.2.3 Absolute XY

For all the multi-touch inputs, the absolute finger position (Absolute X/Y), in the selected resolution (Resolution X/Y) of the trackpad, is available.

5.2.4 Touch Strength

This value (Touch strength) indicates the strength of the touch by giving a sum of all the deltas associated with the finger, and therefore varies according to the sensitivity setup of the sensors.

5.2.5 Area

The number of channels associated with a finger is provided here. This area is usually equal to or smaller than the number of touch channels under the finger.

5.2.6 Tracking / Identification

The fingers are tracked from one cycle to the next, and the same finger will be located in the same position in the memory map. The memory location thus identifies the finger.

5.3 Max Number of Multi-touches

The maximum number of allowed multi-touches is configurable (Max multi-touches) up to 5 points. If more than the selected value is sensed, a flag is set (TOO MANY FINGERS) and the XY data is cleared.



5.4 XY Resolution

The output resolution for the X and Y coordinates are configurable (XY Resolution). The on-chip algorithms use 256 points between each row and column. The resolution is defined as the total X and total Y output range across the complete trackpad.

5.5 Palm Rejection

A maximum finger size/area (Palm reject threshold) can be set up to allow for palm rejection or similar input suppression. This feature can be enabled or disabled (PALM REJECT), and when a palm reject condition is sensed, a status flag will indicate this result (PALM DETECT). All XY outputs are also suppressed during palm detection. Palm reject is latched on for the timeout period (Palm reject timeout) to prevent erratic behaviour before and after the palm is seen. This timeout sets in increments of 32ms.

5.6 Stationary Touch

A stationary touch is defined as a point that does not move outside of a certain boundary within a specific time. This movement boundary or threshold can be configured (Stationary touch movement threshold), and is defined as a movement in either X or Y in the configured resolution.

The device will switch to *Idle-Touch* mode when a stationary point is detected, where a lower duty cycle can be implemented to save power in applications where long touches are expected.

If movement is detected, a status flag (TP MOVEMENT) is set.

5.7 Multi-touch Finger Split

The position algorithm looks at areas (polygons) of touches and calculates positional data from this. Two fingers in close proximity to each other could have areas touching, which would merge them incorrectly into a single point. A finger split algorithm is implemented to separate these merged polygons into multiple

fingers. There is a finger split aggression factor which can be adjusted to determine how aggressive this finger splitting must be implemented. A value of '0' will not split polygons, and thus merge any fingers with touch channels adjacent (diagonally also) to each other.

5.8 XY Output Flip & Switch

By default, X positions are calculated from the first column (usually Rx0) to the last column. Y positions are by default calculated from the first row (usually Tx0) to the last row. The X and/or Y output can be flipped (FLIP X / FLIP Y), to allow the [0, 0] co-ordinate to be defined as desired. The X and Y axes can also be switched (SWITCH XY AXIS) allowing X to be the Tx's, and Y to be along the Rx's.

5.9 XY Position Filtering

Stable XY position data is available from the IQS5xx due to two on-chip filters, namely the Moving Average (MAV) filter, and the Infinite Impulse Response (IIR) filter. The filters are applied to the raw positional data in the aforementioned order. It is recommended to keep both of the filters enabled for optimal XY data.

5.9.1 MAV Filter

If enabled (MAV FILTER), raw XY points from the last two cycles are averaged to give the filter output.

5.9.2 IIR Filter

The IIR filter, if enabled (IIR FILTER), can be configured to select between a dynamic and a static filter (IIR_SELECT).

The damping factor is calculated from the selected *Beta* as follows:

$$\text{Damping factor} = \text{Beta} / 256$$

5.9.2.1 Dynamic Filter

Relative to the speed of movement of a co-ordinate, the filter dynamically adjusts the amount of filtering (damping factor) performed.



When fast movement is detected, and quick response is required, less filtering is done. Similarly, when a co-ordinate is stationary or moving at a slower speed, more filtering can be applied.

The damping factor is adjusted depending on the speed of movement. Three of these parameters are adjustable to fine-tune the dynamic filter if required (XY dynamic bottom beta / XY dynamic lower speed / XY dynamic upper speed).

The speed is defined as the distance (in the selected resolution) travelled in one cycle (pixels/cycle).

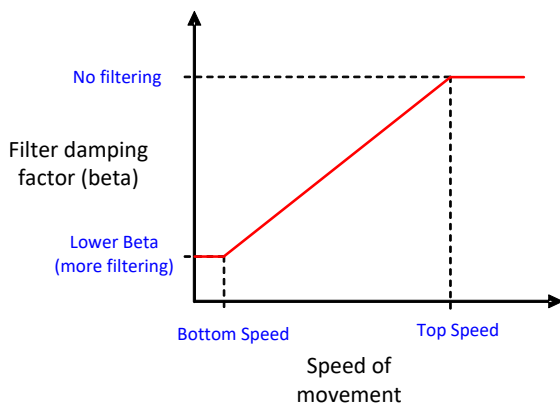

Figure 5.1 Dynamic Filter Parameters

5.9.2.2 Static Filter

Co-ordinates filtered with a fixed but configurable damping factor (XY static beta) are obtained when using the static filter. It is recommended that the dynamic filter is used due to the advantages of a dynamically changing damping value.

6 Gestures

The IQS5xx has an on-chip gesture recognition feature. The list of recognisable gestures includes:

- > 1 finger gestures (GESTURE EVENTS 0):
 - A single tap
 - A press and hold
 - Swipe X+
 - Swipe X-
 - Swipe Y+

- Swipe Y-
- > 2 finger gestures (GESTURE EVENTS 1):
 - 2 simultaneous taps
 - Scroll
 - Zoom

Each single finger gesture can individually be enabled and disabled by setting or clearing the corresponding bits in the register SINGLE FINGER GESTURES. The multi finger gestures can be enabled and disabled via the register MULTI FINGER GESTURES.

All gestures are calculated relative to their starting coordinates, i.e., the first coordinate at which the touch was detected. Furthermore, if at any time during a gesture, more than the required number of touches is detected, the gesture will be invalidated.

6.1 Single Tap

The single tap gesture requires that a touch is made and released in the same location and within a short period of time. Some small amount of movement from the initial coordinate must be allowed to compensate for shift in the finger coordinate during the release. This bound is defined in register Tap distance, which specifies the maximum deviation in pixels the touch is allowed to move before a single tap gesture is no longer valid.

Similarly, the Tap time register defines the maximum duration in ms that will result in a valid gesture. That is, the touch should be released before the time period in Tap time is reached.

A valid single tap gesture will be reported (SINGLE TAP) in the same processing cycle as the touch release was detected, and will be cleared on the next cycle. No movement will be reported in the relative XY registers (Relative X and Relative Y) during this gesture.

Since the gesture reports after the finger is removed, the location of the tap gesture is placed in the Absolute X/Y registers of finger 1 at this time. With Number of fingers set to 0, this will not look like an active finger, and is just



a repetition of the location of the tap that has occurred for the main controller to utilise.

6.2 Press and Hold

The same register that defines the bounds for the single tap gesture (Tap distance) is used for the press and hold gesture. If the touch deviates more than the specified distance, the gesture is no longer valid.

However, if the touch remains within the given bound for longer than the period in ms, defined as the sum of the register values in Tap time and Hold time, a press and hold gesture will be reported (PRESS AND HOLD). The gesture will continue to be reported until the touch is released or if a second touch is registered.

No data will be reported in Relative X and Relative Y before the defined maximum hold period is reached, however, the relative data will be reported thereafter. This allows for features such as drag-n-drop.

6.3 Swipe (X-, X+, Y-, Y+)

All four swipe gestures work in the same manner and are only differentiated in their direction. The direction is defined with respect to the origin (0, 0) of the trackpad, typically at Rx0, Tx0 (Channel 0). If the touch is moving away from the origin, it is considered a positive swipe (+) and if it is moving towards the origin, it is a negative swipe (-). Whether the swipe is of the type X or Y is defined by which axis the touch is moving approximately parallel to.

A swipe gesture event is only reported when a moving touch meets all three of the following conditions:

1. A minimum distance is travelled from its initial coordinates, as defined in pixels by the value in register Swipe initial distance.
2. The distance in (1) is covered within the time specified in Swipe initial time (in ms).
3. The angle of the swipe gesture, as determined by its starting coordinate and the coordinate at which conditions (1) and (2) were first met, does not exceed the

threshold in Swipe angle with regards to at least 1 of the axes. The value in register Swipe angle is calculated as $64 \tan \theta$, where θ is the desired angle (in degrees).

The respective swipe gesture will be reported for 1 cycle (SWIPE X-, X+, Y- Y+) when all of these conditions are met. The relative distance travelled will be reported in registers Relative X and Relative Y throughout.

It is also possible to generate consecutive swipe gesture events during the same swipe gesture by defining the swipe gesture settings in registers Swipe consecutive distance [pixels] and Swipe consecutive time [ms]. Once the initial swipe gesture conditions are met as defined above, the parameters of Swipe initial distance [pixels] and Swipe initial time [ms] will be replaced with these. Also, the gesture engine will reset its properties, thus evaluating the current touch's movement as if its initial coordinate was at the point at which the previous swipe gesture was recognised and as if it first occurred at that point in time.

The consecutive events allow for the continuous stream of swipe events for a single action by the user. However, once the initial conditions are satisfied, the direction of the swipe gesture is fixed. For example, if a swipe X+ gesture is recognised by the engine, the consecutive swipe gestures will also be of type X+. And the 3rd condition will only be evaluated against the X axis.

In the case that only a single event is desired, the settings in Swipe consecutive distance can be set to its maximum value and Swipe consecutive time set to zero. This would make it impossible to meet these conditions on a standard trackpad.

6.4 Two Finger Tap

The simultaneous tap gesture simply requires two tap gestures to occur simultaneously. For this reason the gesture uses the same parameters (Tap distance and Tap time) as that of the tap gesture. It is also confined to the



same conditions for the output to be reported (2_FINGER_TAP).

6.5 Scroll

A scroll gesture is identified by two simultaneous and parallel moving touches. A scroll gesture will be reported (SCROLL) once the average distance travelled by the two touches in pixels exceeds the value stored in register Scroll initial distance. Thereafter, a scroll gesture will continuously be reported until one of the touches is released or if a zoom gesture is validated.

Similar to the swipe gestures, the scroll gestures are also bounded by a given angle to the axis (Scroll angle). The value in this register is calculated as $64 \tan \theta$, where θ is the desired angle (in degrees). This condition is only enforced during the initial validation stage of the scroll gesture.

The direction of the scroll gesture is defined by the reported relative X (horizontal scroll) and Y (vertical scroll) data. For instance, a positive relative X value will correspond with the direction of a swipe X+ gesture. Unlike the swipe gestures, a scroll gesture may alternate between a positive and negative direction without requiring the validation of the initial conditions. However, switching between the axes will require the validation.

At any given stage during a scroll gesture, only the axis applicable to the gesture will have a non-zero value in its relative data register. For example, a scroll parallel to the X-axis will have a non-zero Relative X value and a zero Relative Y value. This value relates to the movement of the scroll gesture.

6.6 Zoom

Zoom gestures require two touches moving toward (zoom out) or away (zoom in) from each other. Similar to the scroll and swipe gestures, the zoom requires that an initial distance threshold in the register Zoom initial distance [pixels] is exceeded before a zoom gesture is reported (ZOOM). Thereafter, the register

Zoom Consecutive Distance defines the distance threshold for each zoom event that follows the initial event. The direction/axis along which the two touches move is not relevant.

Switching from a zoom in to a zoom out gesture, or vice versa, requires that the initial conditions be met in the opposite direction before the switch can occur. Alternating between a zoom and a scroll gesture requires the same.

The size of each zoom event will be reported in Relative X, where the negative sign indicates a zoom out gesture and a positive sign a zoom in gesture.

6.7 Switching Between Gestures

For all single finger gestures, it is necessary to release all touches before any new gesture can be made and validated. However, for the scroll and zoom gestures, it is possible to alternate between the gestures and their directions without releasing any touches.

A switch between multi-touch gestures includes

- > Alternating between scroll axes
- > Alternating between zoom in and out
- > Going from a scroll to a zoom gesture
- > Going from a zoom to a scroll gesture
- > Releasing any one of the two touches
- > Having more than 2 touches on the trackpad at any given moment.

A release of 1 of the touches will require a new touch be generated before any multi-touch gesture can be validated. The multi-touch gestures require 2, and only 2, touches at all time during the gesture.

7 Additional Features

7.1 Non-volatile Defaults

The designer can use the supplied GUI to easily configure the optimal settings for different setups. The design specific firmware is then exported by the GUI and programmed



onto the IQS5xx. These parameters are used as the default values after start-up, without requiring any setup from the master.

Two registers (*Export file version number*) are available so that the designer can label and identify the exported HEX file with the corresponding settings. This allows the master to verify if the device firmware has the intended configuration as required.

7.2 Automated Start-up

The IQS5xx is programmed with the trackpad application firmware, bundled with settings specifically configured for the current hardware as described in Section 7.1. After power-up the IQS5xx will automatically use the settings and configure the device accordingly.

7.3 Suspend

The IQS5xx can be placed into a suspended state (*SUSPEND*). No processing is performed, minimal power is consumed (<1uA), and the device retains existing data.

An automatic reseed of the trackpad is triggered after the IQS5xx is woken from suspend, since it cannot be guaranteed that the reference values are still relevant.

7.3.1 I²C Wake

The device can be woken from suspend by addressing it on the I²C bus. It will respond with a not-acknowledge (NACK) on the first addressing attempt and with an acknowledge (ACK) on the second addressing attempt, providing that there was at least a time difference of ~150us between the two addressing attempts. The suspend bit must then be disabled in that communication session to resume operations.

7.3.2 Switch Input Pin Wake

The SW_IN input pin can be used to wake the device from suspend (when enabled). The input can be connected to an alternate long-range proximity sensing IC (such as IQS211),

or a mechanical switch/button for example. For more details on the input see Section 7.11.

7.4 Reset

7.4.1 Reset Indication

After a reset, the *SHOW RESET* bit will be set by the system to indicate the reset event occurred. This bit will clear when the master sets the *ACK RESET*, if it becomes set again, the master will know a reset has occurred, and can react appropriately.

7.4.2 Software Reset

The IQS5xx can be reset by means of an I²C command (*RESET*).

7.4.3 Hardware Reset

The NRST pin (active low) can be used to reset the IQS5xx. For more details see Section 0.

7.5 Watchdog Timer (WDT)

A watchdog timer is implemented to prevent any stuck conditions which could occur from ESD events or similar scenarios. The watchdog timeout is set to about 500ms. The watchdog can be disabled (*WDT*), however, this needs to be programmed into the non-volatile defaults, since this only takes effect after a reset.

7.6 RF Immunity

The IQS5xx has immunity to high power RF noise. To improve the RF immunity, extra decoupling capacitors are suggested on V_{REG} and V_{DDHI}.

Place a 100pF in parallel with the 1uF ceramic on V_{REG}. Place a 1uF ceramic on V_{DDHI}. All decoupling capacitors should be placed as close as possible to the V_{DDHI} and V_{REG} pads.

PCB ground planes also improve noise immunity.



7.7 Additional Non-Trackpad Channels

Unused projected capacitance channels can be used to design additional buttons or sliders. Note that the channels will still provide XY data output, which can be ignored (or utilised) by the master.

7.8 Bootloader

A bootloader is included to allow easy application firmware upgrading via the I²C bus, without the need to access the PGM and NRST pins for reprogramming.

For more information, refer to the documentation “*IQS5xx I2C Bootloader v2.x Technical User Guide.pdf*”.

7.8.1 Bootloader Status

The bootloader status register can be used to confirm the availability/presence of the bootloader (*Bootloader status*).

Table 7.1 Bootloader Status

Register value	Status
0xA5	Bootloader is available
0xEE	No bootloader

*Note the bootloader is available on the standard IQS5xx-B000 firmware; this could possibly be unavailable on custom firmware versions.

7.9 Version Information

7.9.1 Product Number

The different IQS5xx devices can be identified by their relevant product numbers.

Table 7.2 Product Number

Product Number (decimal)	Device
40	IQS550
58	IQS572
52	IQS525

7.9.2 Project Number

The project number for the generic B000 project is 15 (decimal) for all devices.

7.9.3 Major and Minor Versions

These will vary as the B000 is updated, this datasheet relates to the version as indicated at the bottom of the *Overview* Section 1.

7.10 Unique ID

A 12-byte unique ID can be read from memory map address 0xF000 – 0xF00B. This number gives each individual IC a unique identifier.

7.11 Switch Input

The SW_IN (switch input) pin, when enabled (*SW_INPUT*), will display the state of the input pin to the master controller (*SWITCH_STATE*). This state is updated before each I²C session.

The input can be configured as active LOW or active HIGH (*SW_INPUT_SELECT*). For active LOW, an internal pull-up resistor (typical value of 40kΩ) is connected to the SW_IN pin.

A change in the state of the SW_IN can also trigger an event, see Section 8.8.1. This input can be used as an additional switch or proximity sensor and has the ability to wake the IQS5xx from the extreme (<1uA) low power suspend state.

8 I2C

The IQS5xx communicates via the standard I²C communication protocol.

Clock stretching can occur, thus monitoring the availability of the SCL is required, as per standard I²C protocol.

8.1 Data Ready (RDY)

An additional RDY I/O indicates (active HIGH) when the communication window is available with new data for optimal response. Polling can however be used but is not recommended. RDY should be connected to an interrupt-on-



change input for easier implementation and optimal response time.

8.2 Slave Address

The default 7-bit device address is '1110100'. The device address can be modified during programming. The full address byte will thus be 0xE9 (read) or 0xE8 (write).

8.3 16-bit Addressing

The I²C employs a 16-bit address to access all individual registers in the memory map.

8.4 I²C Read

The master can read from the device at the *current address* if the address is already set up, or when reading from the default address.

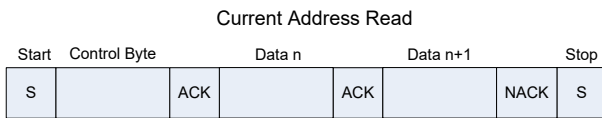

Figure 8.1 Current Address Read

The master can perform a *random read* by specifying the address. A WRITE is performed to set up the address, and a repeated start is used to initiate the READ section.

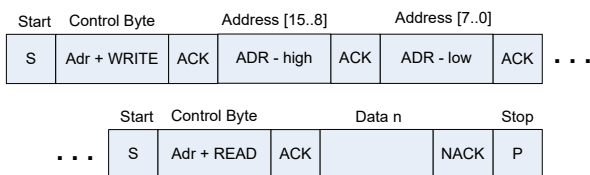

Figure 8.2 Random Read

8.4.1 Default Read Address

When a new communication window begins, the configurable *default read address* is used if a current address read is performed (no address is specified). If an application will always read from a specific register, the IQS5xx can be configured to point to the required register, negating the need to specify the address at each new communication window, allowing for faster data reading.

8.5 I²C Write

The master uses a *Data Write* to write settings to the device. A 16-bit data address is always required, followed by the relevant data bytes to write to the device.

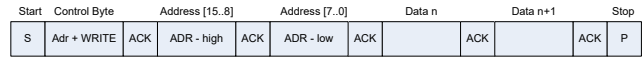

Figure 8.3 Data Write

8.6 I²C Timeout

If the communication window is not serviced within the *I²C timeout* period (in milliseconds), the session is ended (RDY goes LOW), and processing continues as normal. This allows the system to continue and keep reference values up to date even if the master is not responsive.

8.7 End of Communication Session / Window

Unlike the previous A000 implementation, an I²C STOP will **not** terminate the communication window. When all required I²C transactions have been completed, the communication session must be terminated manually. This is achieved by sending the *End Communication Window* command, by writing a single byte (any data) to the address 0xEEEE, followed by a STOP. This will end the communication window, RDY will go low and the IQS5xx will continue with a new sensing and processing cycle.

8.8 Event Mode Communication

The device can be set up to bypass the communication window when no activity is sensed (*EVENT MODE*). This is usually enabled since the master does not want to be interrupted unnecessarily during every cycle if no activity occurred. The communication will resume (RDY will indicate available data) if an enabled event occurs. It is recommended that the RDY be placed on an interrupt-on-pin-change input on the master.



8.8.1 Events

Numerous events can be individually enabled to trigger communication, they are:

- > Trackpad events (TP_EVENT): event triggered if there is a change in X/Y value, or if a finger is added or removed from the trackpad
- > Proximity events (PROX_EVENT): event only triggers if a channel has a change in a proximity state
- > Touch events (TOUCH_EVENT): event only triggers if a channel has a change in a touch state
- > Snap (SNAP_EVENT): event only triggers if a channel has a change in a snap state
- > Re-ATI (REATI_EVENT): one cycle is given to indicate the Re-ATI occurred (REATI_OCCURRED).
- > Proximity on ALP (ALP_PROX_EVENT): event given on state change
- > Switch input (SW_INPUT_EVENT): event triggers if there is a change in the input pin state.

The proximity/touch/snap events are therefore mostly aimed at channels that are used for traditional buttons, where you want to know only when a status is changed.

8.8.2 Force Communication

The master can initiate communication with the IQS5xx, even while RDY is LOW. The IQS5xx will clock stretch until an appropriate time to complete the I²C transaction. The master firmware will not be affected (as long as clock stretching is correctly handled).

For optimal program flow, it is suggested that RDY is used to sync on new data from the IQS5xx. The forced method is only recommended if the master must perform I²C and *Event Mode* is active.

NOTE: *If the IQS5xx is in a low-power state when the master forces the communication, the first addressing will respond with a NACK. The master must repeat the addressing (wait a minimum of 150us after the I²C STOP before retrying), and the IQS5xx will be ready and ACK the transaction.*

Figure 8.4 shows a forced communication transaction. Communication starts with RDY = LOW. The IQS5xx is in a low power state on the first request, and a NACK is sent. After the second request the IQS5xx responds with an ACK. The IQS5xx clock stretches until the communication window becomes active. When the communication window is ready, the clock is released (and RDY is set) and the transaction completes as normal.

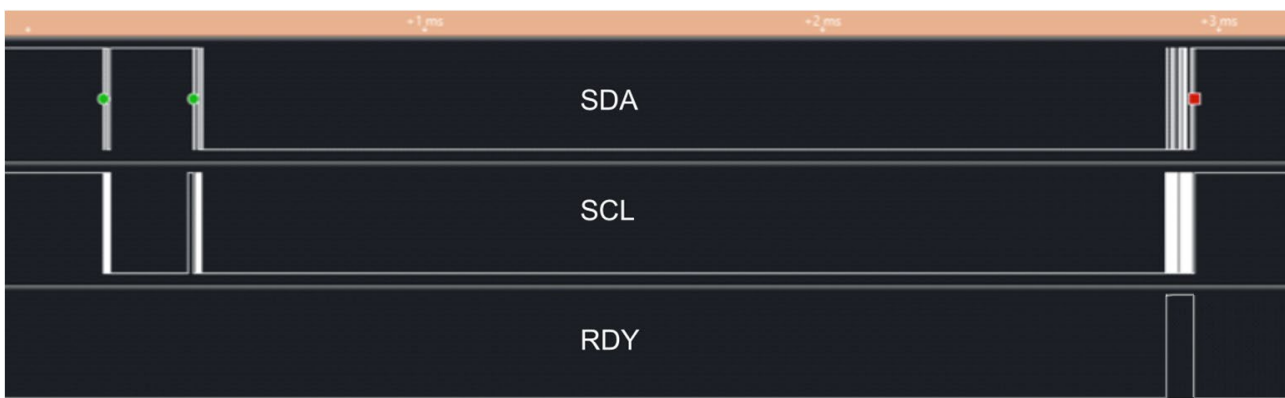

Figure 8.4 Forced communication



8.9 Memory Map Registers

The registers available in the memory map, via I²C, are provided in this section. The memory map starts with a READ-ONLY section, followed by a READ/WRITE section. The read/write permissions are indicated by the

shading in the 'R' (read) and/or 'W' (write) columns.

Certain registers in the memory map have defaults loaded from non-volatile memory, which can be configured during programming; these are highlighted also in the 'E²' column.



Table 8.1 Direct-Addressable Memory Map

Address	Bit7	Bit6	Bit5	Bit4	Bit3	Bit2	Bit1	Bit0	Details	R	W	E ²
0x0000 - 0x0001	Product number (2 bytes)								(See 7.9)			
0x0002 - 0x0003	Project number (2 bytes)											
0x0004	Major version											
0x0005	Minor version											
0x0006	Bootloader status								(See 7.8.1)			
0x0007 - 0x000A	Open (4 bytes)											
0x000B	Max touch column				Max touch row				(See 3.5.5)			
0x000C	Previous cycle time [ms]								(See 4.1.1)			
0x000D	-	-	SWIPE_ Y-	SWIPE_ Y+	SWIPE_ X+	SWIPE_ X-	PRESS_ AND_ HOLD	SINGLE _TAP	Gesture Events 0			
0x000E	-	-	-	-	-	ZOOM	SCROLL	2_ FINGER_ TAP	Gesture Events 1			
0x000F	SHOW_ RESET	ALP_ REATI_ OCCUR RED	ALP_ ATI_ ERROR	REATI_ OCCUR RED	ATI_ ERROR	CHARGING_MODE			System Info 0			
0x0010	-	-	SWITCH_ _STATE	SNAP_ TOGGLE	RR_ MISSED	TOO_ MANY_ FINGERS	PALM_ DETECT	TP_ MOVE- MENT	System Info 1			
0x0011	Number of fingers								(See 5.2.1)			
0x0012 - 0x0013	Relative X [pixels] (2 bytes)								(See 5.2.2)			
0x0014 - 0x0015	Relative Y [pixels] (2 bytes)											
0x0016 - 0x0017	Absolute X position [pixels] (2 bytes)								(See 5.2.3)			
0x0018 - 0x0019	Absolute Y position [pixels] (2 bytes)											
0x001A - 0x001B	Touch strength (2 bytes)								(See 5.2.4)			
0x001C	Touch area / size								(See 5.2.5)			



0x001D : 0x0038	Repeat: <i>Absolute X</i> <i>Absolute Y</i> <i>Touch strength</i> <i>Touch area / size</i> For fingers 2 - 5									
0x0039 - 0x0058	Prox status (32 bytes)							(See 8.10.5)		
0x0059 - 0x0076	Touch status (30 bytes)									
0x0077 - 0x0094	Snap status (30 bytes)									
0x0095 - 0x01C0	Count values (300 bytes)							(See 8.10.6)		
0x01C1 - 0x02EC	Delta values (300 bytes)									
0x02ED - 0x02EE	ALP count value (2 bytes)							(See 3.3.2)		
0x02EF - 0x0302	ALP individual count values (20 bytes)									
0x0303 - 0x042E	Reference values (300 bytes)							(See 8.10.6)		
0x042F - 0x0430	ALP LTA (2 bytes)							(See 3.4.2)		
0x0431	ACK_ RESET	-	AUTO_ ATI	ALP_ RESEED	RESEED	MODE_SELECT		<u>System Control</u> 0		
0x0432	-	-	-	-	-	-	RESET	SUSPEND	<u>System Control</u> 1	
0x0433 - 0x0434	Open (2 bytes)									
0x0435 - 0x043E	ALP ATI compensation (10 bytes)							(See 3.6.2)		
0x043F - 0x04D4	ATI compensation (150 bytes)									
0x04D5 - 0x56A	ATI C individual adjust (150)							(See 3.6.1)		
0x056B	-	-	Global ATI C							
0x056C	-	-	ALP ATI C							
0x056D - 0x056E	ATI target (2 bytes)							(See 3.6.2)		
0x056F - 0x0570	ALP ATI target (2 bytes)									
0x0571	Reference drift limit							(See 3.7.2)		
0x0572	ALP LTA drift limit									



0x0573	Re-ATI lower compensation limit									(See 3.7.3)
0x0574	Re-ATI upper compensation limit									
0x0575 - 0x0576	Max count limit (2 bytes)									(See 3.3.3 and 3.7.2)
0x0577	Re-ATI retry time [s]									(See 3.7.3)
0x0578 - 0x0579	Open (2 bytes)									
0x057A - 0x057B	Report rate [ms] – Active mode (2 bytes)									(See 4.1)
0x057C - 0x057D	Report rate [ms] – Idle touch mode (2 bytes)									
0x057E - 0x057F	Report rate [ms] – Idle mode (2 bytes)									
0x0580 - 0x0581	Report rate [ms] – LP1 mode (2 bytes)									
0x0582 - 0x0583	Report rate [ms] – LP2 mode (2 bytes)									
0x0584	Timeout [s] – Active mode									(See 4.2)
0x0585	Timeout [s] – Idle touch mode									
0x0586	Timeout [s] – Idle mode									
0x0587	Timeout [x 20s] – LP1 mode									
0x0588	Reference update time [s]									(See 3.4.1)
0x0589	Snap timeout [s]									(See 3.5.3)
0x058A	I ² C timeout [ms]									(See 8.6)
0x058B - 0x058D	Open (3 bytes)									
0x058E	MANUAL_CONTROL	SETUP_COMPLETE	WDT	SW_INPUT_EVENT	ALP_REATI	REATI	SW_INPUT_SELECT	SW_INPUT	<u>System Config</u> <u>0</u>	
0x058F	PROX_EVENT	TOUCH_EVENT	SNAP_EVENT	ALP_PROX_EVENT	REATI_EVENT	TP_EVENT	GESTURE_EVENT	EVENT_MODE	<u>System Config</u> <u>1</u>	
0x0590 - 0x0591	Open (2 bytes)									
0x0592 - 0x0593	Snap threshold (2 bytes)									(See 3.5.3)
0x0594	Prox threshold - trackpad									(See 3.5.1)
0x0595	Prox threshold - ALP channel									
0x0596	Global touch multiplier - set									(See 3.5.2)
0x0597	Global touch multiplier - clear									



0x0598 - 0x062D	Individual touch multiplier adjustments (150 bytes)									
0x062E	Minimum count Re-ATI delta								(See 3.7.2)	
0x062F - 0x0631	Open (3 bytes)									
0x0632	-	-	-	-	ALP_COUNT_FILTER	IIR_SELECT	MAV_FILTER	IIR_FILTER	Filter Settings 0	
0x0633	XY static beta								(See 5.9.2.2)	
0x0634	ALP count beta								(See 3.3.2)	
0x0635	ALP1 LTA beta								(See 3.4.2)	
0x0636	ALP2 LTA beta									
0x0637	XY dynamic filter – bottom beta								(See 5.9.2.1)	
0x0638	XY dynamic filter– lower speed									
0x0639 – 0x063A	XY dynamic filter– upper speed (2 bytes)									
0x063B – 0x063C	Open (2 bytes)									
0x063D	Total Rx								(See 5.1.1)	
0x063E	Total Tx									
0x063F - 0x0648	Rx mapping (10 bytes)								(See 5.1.3)	
0x0649 - 0x0657	Tx mapping (15 bytes)									
0x0658	CHARGE_TYPE	RX_GROUP	PROX_REVERSE	ALP	-	-	-	-	ALP Channel Setup 0	
0x0659	-	-	-	-	-	-	ALP_RX9	ALP_RX8	ALP Rx Select	
0x065A	ALP_RX7	ALP_RX6	ALP_RX5	ALP_RX4	ALP_RX3	ALP_RX2	ALP_RX1	ALP_RX0		
0x065B	-	ALP_TX14	ALP_TX13	ALP_TX12	ALP_TX11	ALP_TX10	ALP_TX9	ALP_TX8	ALP Tx Select	
0x065C	ALP_TX7	ALP_TX6	ALP_TX5	ALP_TX4	ALP_TX3	ALP_TX2	ALP_TX1	ALP_TX0		
0x065D	Rx7/Tx2	Rx6/Tx3	Rx5/Tx4	Rx4/Tx5	Rx3/Tx6	Rx2/Tx7	Rx1/Tx8	Rx0/Tx9	RxToTx	
	Rx7/Tx9	Rx6/Tx10	Rx5/Tx11	Rx4/Tx12	Rx3/Tx13	Rx2/Tx14	-	-		
0x065E	Open									
0x065F	-	-	ND	-	-	RX_FLOAT	0	0	Hardware Settings A	
0x0660	-	CK_FREQ			-	-	ANA_DEAD_TIME	INCR_PHASE	Hardware Settings B1	



0x0661	-	CK_FREQ	-	-	ANA_DEAD_TIME	INCR_PHASE	Hardware Settings B2 (ALP)		
0x0662	STAB_TIME	OPAMP_BIAS	VTRIP				Hardware Settings C1		
0x0663	STAB_TIME	OPAMP_BIAS	VTRIP				Hardware Settings C2 (ALP)		
0x0664	-	UPLEN	-	PASSLEN				Hardware Settings D1	
0x0665	-	UPLEN	-	PASSLEN				Hardware Settings D2 (ALP)	
0x0666 - 0x0668	Open (3 bytes)								
0x0669	-	-	-	-	PALM_REJECT	SWITCH_XY_AXIS	FLIP_Y	FLIP_X	XY Config 0
0x066A	Max multi-touches							(See 5.3)	
0x066B	Finger split aggression factor							(See 5.7)	
0x066C	Palm reject threshold							(See 5.5)	
0x066D	Palm reject timeout [x 32ms]								
0x066E - 0x066F	X Resolution [pixels] (2 bytes)							(See 5.4)	
0x0670 - 0x0671	Y Resolution [pixels] (2 bytes)								
0x0672	Stationary touch movement threshold [pixels]							(See 5.6)	
0x0673 - 0x0674	Open (2 bytes)								
0x0675 - 0x0676	Default read address (2 bytes)							(See 8.4.1)	
0x0677 - 0x0678	Export file version number (2 bytes)							(See 7.1)	
0x0679	PROX_DB_SET				PROX_DB_CLEAR				Prox debounce
0x067A	SNAP_DB_SET	TOUCH_DB_SET	SNAP_DB_CLEAR	TOUCH_DB_CLEAR				Touch snap debounce	
0x067B - 0x0698	Active channels (30 bytes)							(See 8.10.5)	
0x0699 - 0x06B6	Snap enabled channels (30 bytes)								
0x06B7	-	-	SWIPE_Y-	SWIPE_Y+	SWIPE_X+	SWIPE_X-	TAP_AND_HOLD	SINGLE_TAP	Single Finger Gestures



0x06B8	-	-	-	-	-	ZOOM	SCROLL	2_FINGER_TAP	Multi Finger Gestures			
0x06B9 - 0x06BA	Tap time [ms] (2 bytes)								(see 6.1 and 6.4)			
0x06BB - 0x06BC	Tap distance [pixels] (2 bytes)											
0x06BD - 0x06BE	Hold time [ms] (2 bytes)								(see 6.2)			
0x06BF - 0x06C0	Swipe initial time [ms] (2 bytes)								(see 6.3)			
0x06C1 - 0x06C2	Swipe initial distance [pixels] (2 bytes)											
0x06C3 - 0x06C4	Swipe consecutive time [ms] (2 bytes)											
0x06C5 - 0x06C6	Swipe consecutive distance [pixels] (2 bytes)											
0x06C7	Swipe angle [64tan(deg)]											
0x06C8 - 0x06C9	Scroll initial distance [pixels] (2 bytes)								(see 6.5)			
0x06CA	Scroll angle [64tan(deg)]											
0x06CB - 0x06CC	Zoom initial distance [pixels] (2 bytes)								(see 6.6)			
0x06CD - 0x06CE	Zoom consecutive distance [pixels] (2 bytes)											
0x06CF	Open (1 byte)											

8.10 Memory Map Bit / Register Definitions

The bit definitions for the registers in the memory map are explained in this section. Also certain parameters that have a multiple number of bytes (registers) are also explained here.

8.10.1 Gesture Events 0

	Gesture Events 0							
Bit	7	6	5	4	3	2	1	0
Name	-	-	SWIPE_Y-	SWIPE_Y+	SWIPE_X+	SWIPE_X-	PRESS_AND_HOLD	SINGLE_TAP

- > Bit 7-6: Unused
- > Bit 5: **SWIPE_Y-**: Swipe in negative Y direction status
 - 0 = No gesture
 - 1 = Swipe in negative Y-direction occurred



- > Bit 4: **SWIPE_Y+**: Swipe in positive Y direction status
 - 0 = No gesture
 - 1 = Swipe in positive Y-direction occurred
- > Bit 3: **SWIPE_X+**: Swipe in positive X direction status
 - 0 = No gesture
 - 1 = Swipe in positive X-direction occurred
- > Bit 2: **SWIPE_X-**: Swipe in negative X direction status
 - 0 = No gesture
 - 1 = Swipe in negative X direction occurred
- > Bit 1: **PRESS_AND_HOLD**: Press and hold gesture status
 - 0 = No gesture
 - 1 = Press and hold occurred
- > Bit 0: **SINGLE_TAP**: Single tap gesture status
 - 0 = No gesture
 - 1 = Single tap occurred

8.10.2 Gesture Events 1

	Gesture Events 1							
Bit	7	6	5	4	3	2	1	0
Name	-	-	-	-	-	ZOOM	SCROLL	2_FINGER_TAP

- > Bit 7-3: Unused
- > Bit 2: **ZOOM**: Zoom gesture status
 - 0 = No gesture
 - 1 = Zoom gesture occurred
- > Bit 1: **SCROLL**: Scroll status
 - 0 = No gesture
 - 1 = Scroll gesture occurred
- > Bit 0: **2_FINGER_TAP**: Two finger tap gesture status
 - 0 = No gesture
 - 1 = Two finger tap occurred

8.10.3 System Info 0

	System Info 0							
Bit	7	6	5	4	3	2	1	0
Name	SHOW_RESET	ALP_REATI_OCCURRED	ALP_ATI_ERROR	REATI_OCCURRED	ATI_ERROR	CHARGING_MODE		

- > Bit 7: **SHOW_RESET**: Indicates a reset
 - 0 = Reset indication has been cleared by host, writing to 'Ack Reset' bit



- 1 = Reset has occurred, and indication has not yet been cleared by host
- > Bit 6: **ALP_REATI_OCCURRED**: Alternate Low Power channel Re-ATI status
 - 0 = No Re-ATI
 - 1 = Re-ATI has just completed on the alternate LP channel
- > Bit 5: **ALP_ATI_ERROR**: Alternate Low Power channel ATI error status
 - 0 = Most recent ATI process was successful
 - 1 = Most recent ATI process had errors
- > Bit 4: **REATI_OCCURRED**: Trackpad Re-ATI status
 - 0 = No Re-ATI
 - 1 = Re-ATI has just completed on the trackpad
- > Bit 3: **ATI_ERROR**: Error condition seen on latest trackpad ATI procedure
 - 0 = Most recent ATI process was successful
 - 1 = Most recent ATI process had errors
- > Bit 2-0: **CHARGING_MODE**: Indicates current mode
 - 000 = Active mode
 - 001 = Idle-Touch mode
 - 010 = Idle mode
 - 011 = LP1 mode
 - 100 = LP2 mode

8.10.4 System Info 1

System Info 1								
Bit	7	6	5	4	3	2	1	0
Name	-	-	SWITCH_STATE	SNAP_TOGGLE	RR_MISSED	TOO_MANY_FINGERS	PALM_DETECT	TP_MOVE-MENT

- > Bit 7-6: Unused
- > Bit 5: **SWITCH_STATE**: Status of input pin SW_IN
 - 0 = SW_IN is LOW
 - 1 = SW_IN is HIGH
- > Bit 4: **SNAP_TOGGLE**: Change in any snap channel status
 - 0 = No change in any channels' snap status
 - 1 = At least one channel has had a change in snap status
- > Bit 3: **RR_MISSED**: Report rate status
 - 0 = Report rate has been achieved
 - 1 = Report rate was not achieved
- > Bit 2: **TOO_MANY_FINGERS**: Total finger status
 - 0 = Number of fingers are within the max selected value
 - 1 = Number of fingers are more than the max selected
- > Bit 1: **PALM_DETECT**: Palm detect status
 - 0 = No palm reject detected
 - 1 = Palm reject has been detected



- > Bit 0: **TP_MOVEMENT**: Activity or movement on trackpad status
 - 0 = No finger or no movement of fingers on trackpad
 - 1 = Movement of finger(s) seen on trackpad

8.10.5 Individual Channel Status / Config Bit Definitions

For all status outputs or configuration parameters where one bit relates to one channel, the structure is defined as shown in the tables below. Each row has a 16-bit value where the status/config of each bit corresponds to the status/config of the corresponding column.

Table 8.2 Status Bytes

Address	Data
X	Status/Config [Row0] – High Byte
X+1	Status/Config [Row0] – Low Byte
X+2	Status/Config [Row1] – High Byte
X+3	Status/Config [Row1] – Low Byte
	⋮
X+28	Status/Config [Row14] – High Byte
X+29	Status/Config [Row14] – Low Byte

*Note that the proximity status bits have two extra bytes appended to the end to include the proximity status bit of the ALP channel. Its status is located at Bit0.

Table 8.3 Status/Config Bit Definitions

	High byte							Low byte								
	-	-	-	-	-	-	Col9	Col8	Col7	Col6	Col5	Col4	Col3	Col2	Col1	Col0
Row Z	Bit15	Bit14	Bit13	Bit12	Bit11	Bit10	Bit9	Bit8	Bit7	Bit6	Bit5	Bit4	Bit3	Bit2	Bit1	Bit0

*Note that if the XY axes are switched, these registers do NOT switch. This means that the bits will always link to Rxs, and the registers will always link to TxS.

For the example above the parameter shown in the grey box in the table above is associated with the Zth Tx and the 6th Rx.

The bit definitions for these parameters are shown in the table below.

Table 8.4 Channel Status/Config Bit Definitions

Parameter	Bit = 0	Bit = 1
Prox status	Channel does not have a proximity	Channel does have a prox
Touch status	Channel does not have a touch	Channel does have a touch
Snap status	Channel does not have a snap	Channel does have a snap
Active channels	Channel disabled	Channel enabled
Snap enabled channels	Snap feature disabled on channel	Snap feature enabled on channel



8.10.6 Count / Delta / Reference Data

For the count, delta and reference values (2 bytes per channel), the structure is defined as shown in the table below.

Table 8.5 Count / Delta / Reference Value Bytes

Byte number	Data	Description
X	Count/Delta/Reference value[0][0] – High Byte	Count, delta or reference @ first Tx, and first Rx (thus top left)
X+1	Count/Delta/Reference value[0][0] – Low Byte	
X+2	Count/Delta/Reference value[0][1] – High Byte	Count, delta or reference @ first Tx, and 2nd Rx
X+3	Count/Delta/Reference value[0][1] – Low Byte	
:	:	:
X+298	Count/Delta/Reference value[14][9] – High Byte	Count, delta or reference @ last Tx, and last Rx (thus bottom right)
X+299	Count/Delta/Reference value[14][9] – Low Byte	

8.10.7 System Control 0

	System Control 0							
Bit	7	6	5	4	3	2	1	0
Name	ACK_RESET	-	AUTO_ATI	ALP_RESEED	RESEED	MODE_SELECT		

- > Bit 7: **ACK_RESET**: Acknowledge a reset
 - 0 = nothing
 - 1 = Acknowledge the reset by clearing SHOW_RESET bit
- > Bit 6: Unused
- > Bit 5: **AUTO_ATI**: Run ATI algorithm
 - 0 = nothing
 - 1 = Run ATI algorithm (affected channels depending on current mode)
- > Bit 4: **ALP_RESEED**: Reseed alternate low power channel
 - 0 = nothing
 - 1 = reseed the LTA of the alternate LP channel
- > Bit 3: **RESEED**: Reseed trackpad channels
 - 0 = nothing
 - 1 = Reseed reference values of trackpad
- > Bit 2-0: **MODE_SELECT**: Select mode (only applies in *Manual Mode*)
 - 000 = Active mode
 - 001 = Idle-Touch mode
 - 010 = Idle mode
 - 011 = LP1 mode
 - 100 = LP2 mode



8.10.8 System Control 1

System Control 1								
Bit	7	6	5	4	3	2	1	0
Name	-	-	-	-	-	-	RESET	SUSPEND

- > Bit 7-2: Unused
- > Bit 1: **RESET**: Reset the IQS5xx
 - 0 = nothing
 - 1 = Reset the device after the communication window terminates
- > Bit 0: **SUSPEND**: Suspend IQS5xx
 - 0 = nothing
 - 1 = Place IQS5xx into suspend after the communication window terminates

8.10.9 System Config 0

System Config 0								
Bit	7	6	5	4	3	2	1	0
Name	MANUAL_CONTROL	SETUP_COMPLETE	WDT	SW_INPUT_EVENT	ALP_REATI	REATI	SW_INPUT_SELECT	SW_INPUT

- > Bit 7: **MANUAL_CONTROL**: Override automatic mode switching
 - 0 = Modes are automatically controlled by IQS5xx
 - 1 = Manual control of modes are handled by host
- > Bit 6: **SETUP_COMPLETE**: Device parameters are set up
 - 0 = IQS5xx will remain in I²C setup window (no processing yet)
 - 1 = Setup is complete, run auto-start procedure
- > Bit 5: **WDT**: Watchdog timer enable/disable
 - 0 = Watchdog is disabled (only disables after a reset)
 - 1 = Watchdog is enabled
- > Bit 4: **SW_INPUT_EVENT**: Enable switch state change triggering event
 - 0 = Toggle of SW_IN does not trigger an event
 - 1 = Toggle of SW_IN triggers an event
- > Bit 3: **ALP_REATI**: Enable/Disable automatic Re-ATI on alternate LP channel
 - 0 = Re-ATI is disabled for alternate LP channel
 - 1 = Re-ATI is enabled for alternate LP channel
- > Bit 2: **REATI**: Enable/Disable automatic Re-ATI on trackpad
 - 0 = Re-ATI is disabled for trackpad channels
 - 1 = Re-ATI is enabled for trackpad channels
- > Bit 1: **SW_INPUT_SELECT**: Select I/O polarity
 - 0 = SW_IN is active LOW
 - 1 = SW_IN is active HIGH
- > Bit 0: **SW_INPUT**: Enable/disable the input switch function on pin SW_IN



- 0 = Input disabled
- 1 = Input enabled

8.10.10 System Config 1

System Config 1								
Bit	7	6	5	4	3	2	1	0
Name	PROX_EVENT	TOUCH_EVENT	SNAP_EVENT	ALP_PROX_EVENT	REATI_EVENT	TP_EVENT	GESTURE_EVENT	EVENT_MODE

- > Bit 7: **PROX_EVENT**: Enable proximity triggering event
 - 0 = Toggle of proximity status does not trigger an event
 - 1 = Toggle of proximity status triggers an event
- > Bit 6: **TOUCH_EVENT**: Enable touch triggering event
 - 0 = Toggle of touch status does not trigger an event
 - 1 = Toggle of touch status triggers an event
- > Bit 5: **SNAP_EVENT**: Enable snap triggering event
 - 0 = Toggle of snap status does not trigger an event
 - 1 = Toggle of snap status triggers an event
- > Bit 4: **ALP_PROX_EVENT**: Enable alternate LP channel proximity triggering event
 - 0 = Toggle of alternate channel proximity status does not trigger an event
 - 1 = Toggle of alternate channel proximity status triggers an event
- > Bit 3: **REATI_EVENT**: Enable Re-ATI generating an event
 - 0 = Re-ATI occurring does not trigger an event
 - 1 = Re-ATI occurring triggers an event
- > Bit 2: **TP_EVENT**: Enable trackpad events
 - 0 = Trackpad actions will not trigger event
 - 1 = Trackpad actions trigger event
- > Bit 1: **GESTURE_EVENT**: Enable gesture events
 - 0 = Gestures will not trigger event
 - 1 = Gestures will trigger event
- > Bit 0: **EVENT_MODE**: Enable event mode communication
 - 0 = I²C is presented each cycle
 - 1 = I²C is only initiated when an enabled event occurs

8.10.11 Filter Settings 0

Filter Settings 0								
Bit	7	6	5	4	3	2	1	0
Name	-	-	-	-	ALP_COUNT_FILTER	IIR_SELECT	MAV_FILTER	IIR_FILTER

- > Bit 7-4: Unused



- > Bit 3: **ALP_COUNT_FILTER**: Enable alternate LP channel count filtering
 - 0 = Alternate LP channel counts are unfiltered
 - 1 = Alternate LP channel counts are filtered
- > Bit 2: **IIR_SELECT**: Select the IIR filtering method for the XY data points
 - 0 = Damping factor for IIR filter is dynamically adjusted relative to XY movement
 - 1 = Damping factor for IIR filter is fixed
- > Bit 1: **MAV_FILTER**: Enable moving averaging filter
 - 0 = XY MAV filter disabled
 - 1 = XY MAV filter enabled
- > Bit 0: **IIR_FILTER**: Enable IIR filter
 - 0 = XY IIR filter disabled
 - 1 = XY IIR filter enabled

8.10.12 Alternate Channel Setup

	ALP Channel Setup 0							
Bit	7	6	5	4	3	2	1	0
Name	CHARGE_TYPE	RX_GROUP	PROX_REVERSE	ALP	-	-	-	-

- > Bit 7: **CHARGE_TYPE**: Charge type selection
 - 0 = Projected capacitive charging
 - 1 = Self capacitive charging
- > Bit 6: **RX_GROUP**: Select Rx group
 - 0 = Rx group A
 - 1 = Rx group B
- > Bit 5: **PROX_REVERSE**: Enable reverse proximity sensing
 - 0 = Allow proximity to only trigger in conventional direction (positive for projected, negative for self capacitive)
 - 1 = Proximity detects change in counts in both directions
- > Bit 4: **ALP**: Enable alternate low power channel
 - 0 = LP1 and LP2 use trackpad channels
 - 1 = LP1 and LP2 use alternate channel configuration
- > Bit 3-0: Unused

8.10.13 ALP Rx select

- > Bit Z: **ALP_RxZ**: Select Rx for alternate low power channel
 - 0 = RxZ is not part of ALP channel
 - 1 = RxZ is part of ALP channel

8.10.14 ALP Tx select

- > Bit Z: **ALP_TxZ**: Select Tx for alternate low power channel
 - 0 = TxZ is not part of ALP channel
 - 1 = TxZ is part of ALP channel



8.10.15 RxToTx

	RxToTx ⁽¹⁾							
Bit	7	6	5	4	3	2	1	0
IQS525	Rx7/Tx2	Rx6/Tx3	Rx5/Tx4	Rx4/Tx5	Rx3/Tx6	Rx2/Tx7	Rx1/Tx8	Rx0/Tx9
IQS572	Rx7/Tx9	Rx6/Tx10	Rx5/Tx11	Rx4/Tx12	Rx3/Tx13	Rx2/Tx14	0	0

- > Bit 7-0: **Rx/Tx**: Change an Rx electrode to a Tx electrode
 - 0 = Activate indicated Rx
 - 1 = Activate indicated Tx

1: This register is only available on the IQS572 and IQS525 firmware

8.10.16 Hardware Settings A

	Hardware Settings A							
Bit	7	6	5	4	3	2	1	0
Name	-	-	ND	-	-	RX_FLOAT	0	0

- > Bit 7-6: Unused
- > Bit 5: **ND**: Enable hardware noise detection
 - 0 = noise detect disabled
 - 1 = noise detect enabled
- > Bit 4-3: Unused
- > Bit 2: **RX_FLOAT**: Select Rx status when inactive
 - 0 = Rx is grounded when inactive
 - 1 = Rx is floating when inactive
- > Bit 1-0: **Internal use, set to 0**

8.10.17 Hardware Settings B

	Hardware Settings B								
Bit	7	6	5	4	3	2	1	0	
Name	-	CK_FREQ			-	-	ANA_DEAD_TIME	INCR_PHASE	

- > Bit 7: Unused
- > Bit 6-4: **CK_FREQ**: Configure Prox module clock source
 - 000 = 125kHz
 - 001 = 250kHz
 - 010 = 500kHz
 - 011 = 1MHz
 - 100 = 2MHz
 - 101 = 4MHz



- 110 = 8MHz
- 111 = 16MHz
- > Bit 3-2: Unused
- > Bit 1: **ANA_DEAD_TIME**: Analog dead time between up and pass phase
 - 0 = Analog dead time disabled (dead time is half a prox clock cycle)
 - 1 = Analog dead time enabled (dead time is ~10ns, and UP increased by one cycle)
- > Bit 0: **INCR_PHASE**: Increase the phase length of UP and PASS
 - 0 = Phase (UP / PASS) not incremented
 - 1 = Phase (UP / PASS) increased by one half of a prox clock cycle

8.10.18 Hardware Settings C

Hardware Settings C								
Bit	7	6	5	4	3	2	1	0
Name	STAB_TIME		OPAMP_BIAS		VTRIP			

- > Bit 7-6: **STAB_TIME**: Stabilisation time after module power-on before conversion starts
 - 00 = 1.7ms
 - 01 = 500us
 - 10 = 120us
 - 11 = no not use
- > Bit 5-4: **OPAMP_BIAS**: Opamp bias strength
 - 00 = 2.5uA
 - 01 = 5uA
 - 10 = 7.5uA
 - 11 = 10uA
- > Bit 3-0: **VTRIP**: Charge transfer trip voltage
 - Trip voltage = $[0.5 + (VTRIP \times 0.0267)] \times V_{reg}$

8.10.19 Hardware Settings D

Hardware Settings D								
Bit	7	6	5	4	3	2	1	0
Name	-	UPLEN			-	PASSLEN		

- > Bit 7: Unused
- > Bit 6-4: **UPLEN**: Length of UP phase
- > Bit 3: Unused
- > Bit 2-0: **PASSLEN**: Length of PASS phase



8.10.20 XY Config 0

XY Config 0								
Bit	7	6	5	4	3	2	1	0
Name	-	-	-	-	PALM_REJECT	SWITCH_XY_AXIS	FLIP_Y	FLIP_X

- > Bit 7-4: Unused
- > Bit 3: **PALM_REJECT**: Enable palm reject sensing and suppression
 - 0 = Large fingers (palms) are allowed
 - 1 = Large fingers (palms) will block XY outputs
- > Bit 2: **SWITCH_XY_AXIS**: Switch X and Y outputs
 - 0 = Columns Rx0-Rx9 gives change in X, rows Tx0-Tx14 gives change in Y
 - 1 = Columns Tx0-Tx14 gives change in X, rows Rx0-Rx9 gives change in Y
- > Bit 1: **FLIP_Y**: Flip Y output values
 - 0 = Keep default Y values
 - 1 = Invert Y output values
- > Bit 0: **FLIP_X**: Flip X output values
 - 0 = Keep default X values
 - 1 = Invert X output values

8.10.21 Single Finger Gestures

Single Finger Gestures								
Bit	7	6	5	4	3	2	1	0
Name	-	-	SWIPE_Y-	SWIPE_Y+	SWIPE_X+	SWIPE_X-	PRESS_AND_HOLD	SINGLE_TAP

- > Bit 7-6: Unused
- > Bit 5: **SWIPE_Y-**: Swipe in negative Y direction
 - 0 = Gesture disabled
 - 1 = Gesture enabled
- > Bit 4: **SWIPE_Y+**: Swipe in positive Y direction
 - 0 = Gesture disabled
 - 1 = Gesture enabled
- > Bit 3: **SWIPE_X+**: Swipe in positive X direction
 - 0 = Gesture disabled
 - 1 = Gesture enabled
- > Bit 2: **SWIPE_X-**: Swipe in negative X direction
 - 0 = Gesture disabled
 - 1 = Gesture enabled
- > Bit 1: **PRESS_AND_HOLD**: Press and hold gesture
 - 0 = Gesture disabled
 - 1 = Gesture enabled



- > Bit 0: **SINGLE_TAP**: Single tap gesture
 - 0 = Gesture disabled
 - 1 = Gesture enabled

8.10.22 Multi-finger Gestures

Multi-finger Gestures								
Bit	7	6	5	4	3	2	1	0
Name	-	-	-	-	-	ZOOM	SCROLL	2F_TAP

- > Bit 7-3: Unused
- > Bit 2: **ZOOM**: Zoom gestures
 - 0 = Gestures disabled
 - 1 = Gestures enabled
- > Bit 1: **SCROLL**: Scroll gestures
 - 0 = Gestures disabled
 - 1 = Gestures enabled
- > Bit 0: **2F_TAP**: Two finger tap gesture
 - 0 = Gesture disabled
 - 1 = Gesture enabled

9 Circuit Diagram

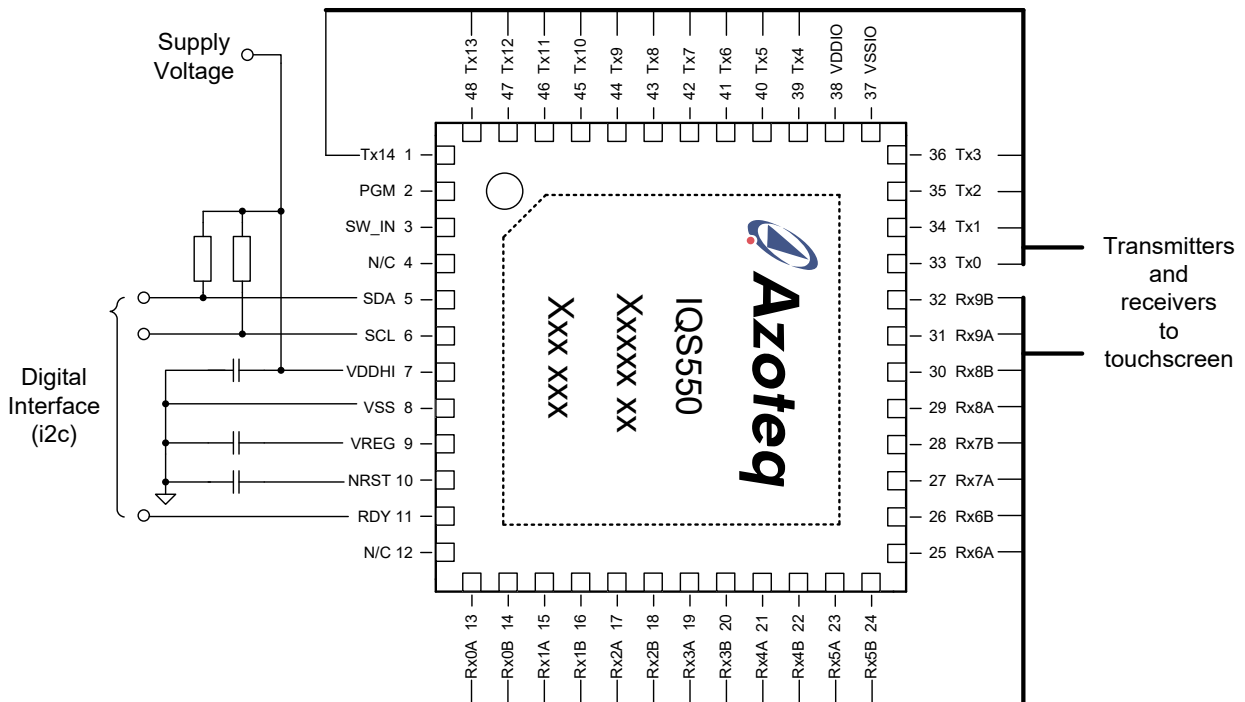

Figure 9.1 IQS550 Overview Diagram

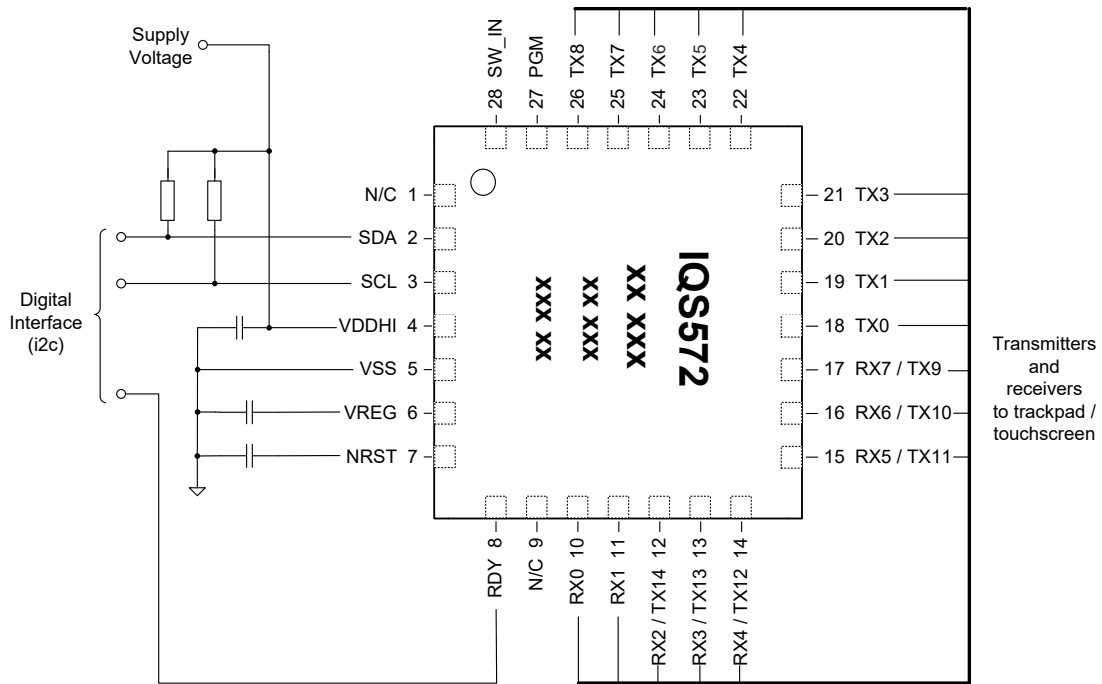

Figure 9.2 IQS572 Overview Diagram

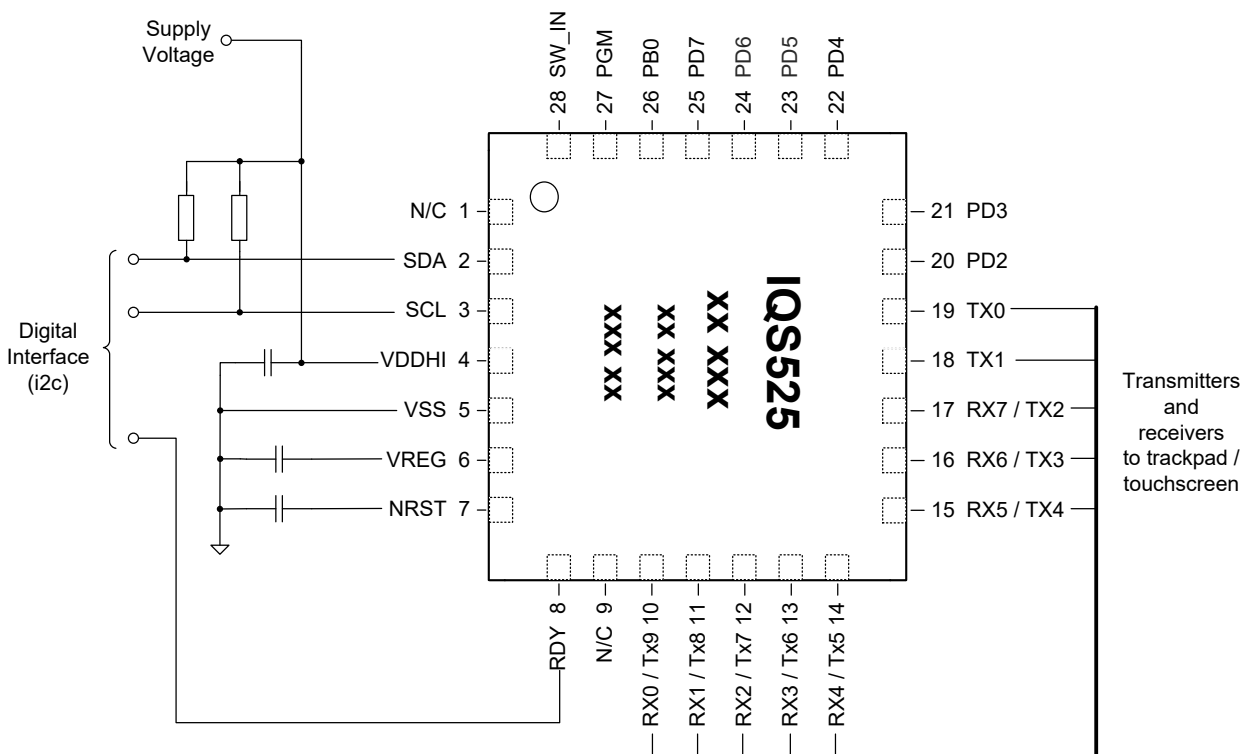

Figure 9.3 IQS525 Overview Diagram

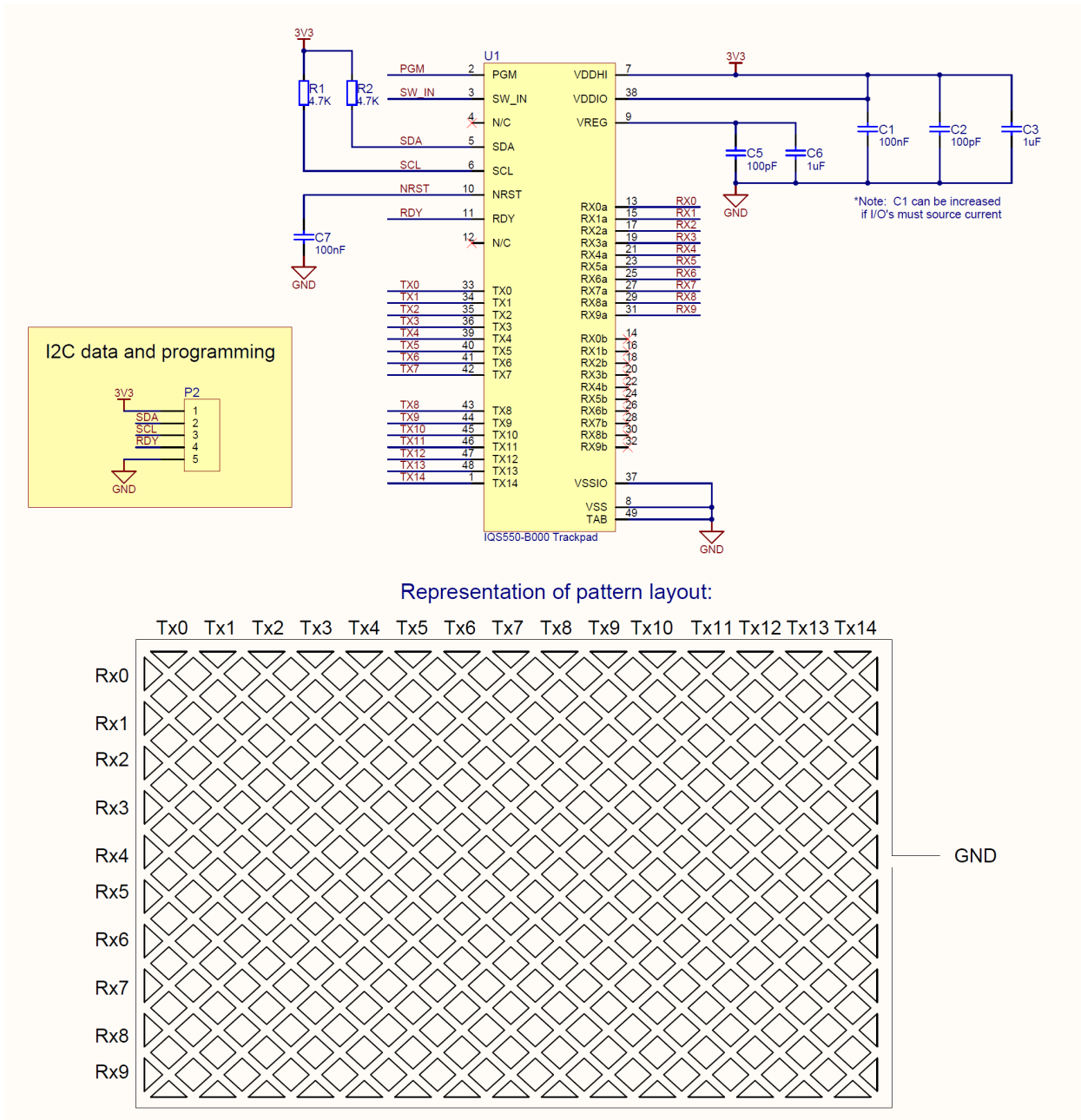

Figure 9.4 IQS550 Application Circuit

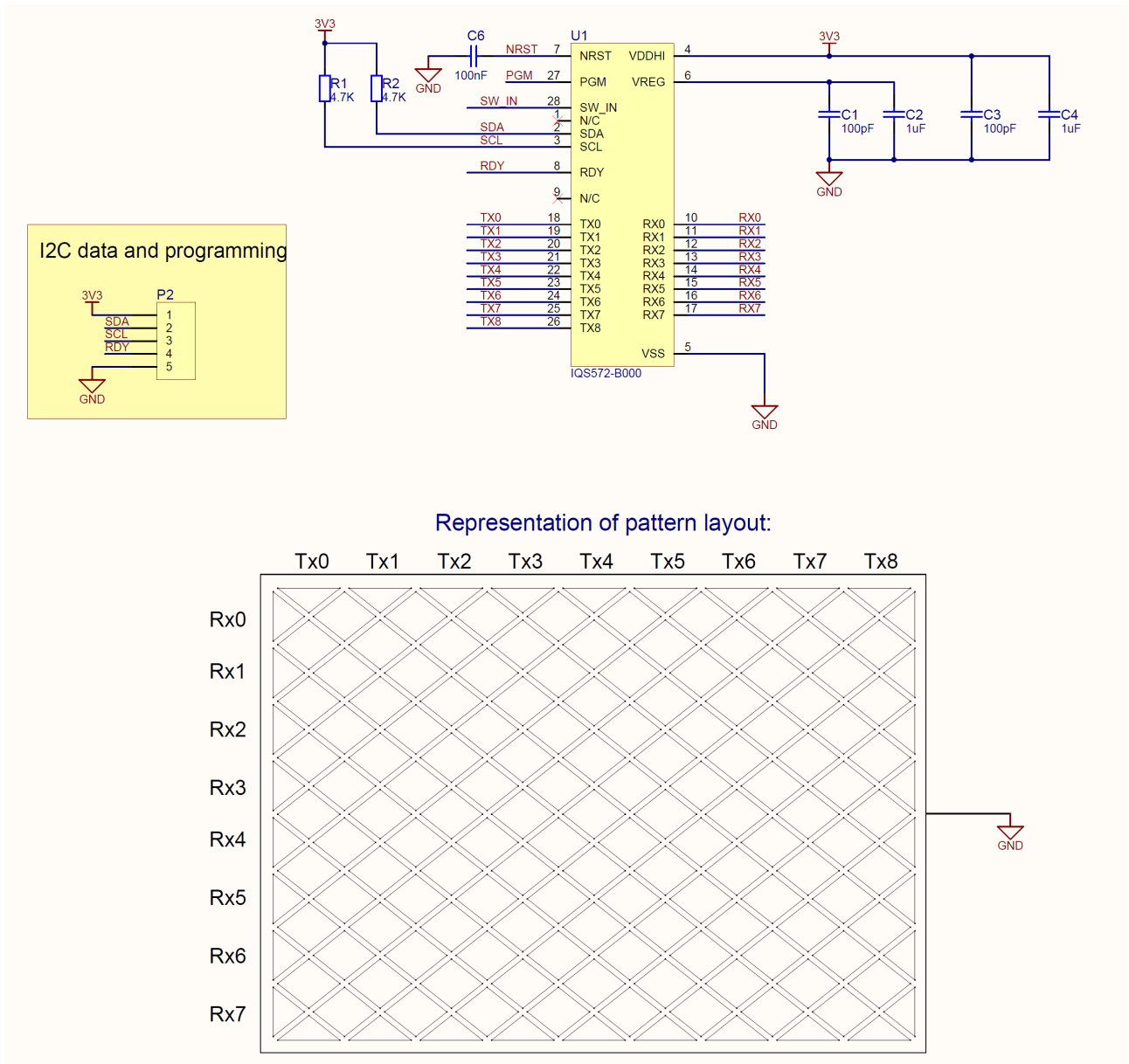

Figure 9.5 IQS572 Application Circuit

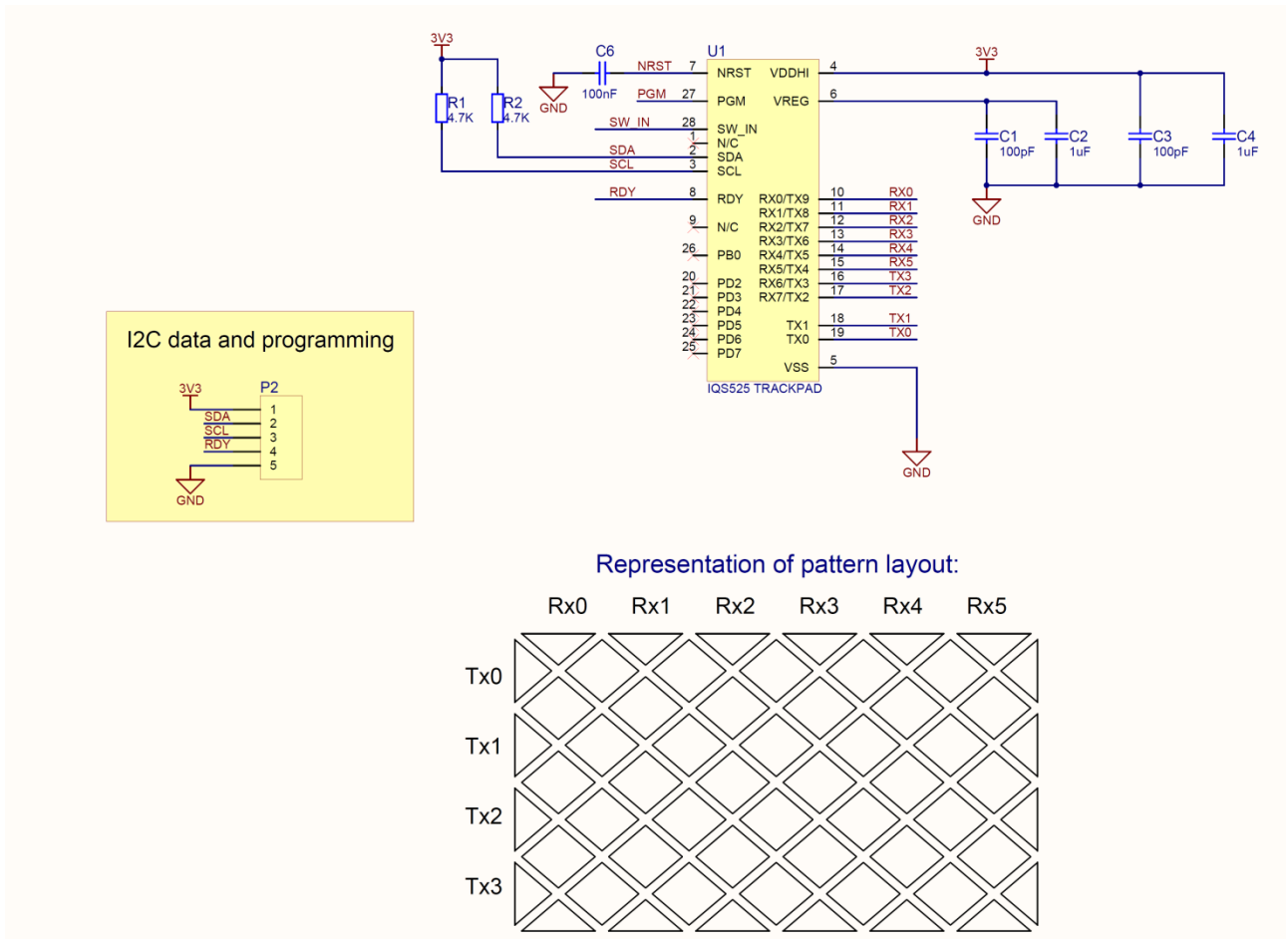

Figure 9.6 IQS525 Application Circuit



10 Electrical Characteristics

10.1 Absolute Maximum Ratings

Exceeding these maximum ratings may cause permanent damage to the device.

Table 10.1 Voltage Characteristics

Symbol	Rating	Min	Max	Unit	
$V_{DDHI} - V_{SS}$	External supply voltage	-0.3	4.0	V	
V_{IN}	Receiver channel pins (Rx0A...Rx9B)	$V_{SS}-0.3$	$V_{REG} (-1.55)$		
	Input voltage on transmit pins (Tx0...Tx14))	PXS off	$V_{SS}-0.3$		4.0
		PXS on ⁽¹⁾	$V_{SS}-0.3$		$V_{REG} (-1.55)$
	Input voltage on any pin ⁽²⁾	$V_{SS}-0.3$	4.0		

1. If the ProxSense® peripheral is on, no injection must be performed on any pin having the transmit function (Tx) as an alternate function, even if this alternate function is not specified
2. $I_{INJ(PIN)}$ must never be exceeded. This is implicitly insured if V_{IN} maximum is respected. If V_{IN} maximum cannot be respected, the injection current must be limited externally to the $I_{INJ(PIN)}$ value. A positive injection is induced by $V_{IN} > V_{DDHI}$ while a negative is induced by $V_{IN} < V_{SS}$.

Table 10.2 Current Characteristics

Symbol	Rating	Max.	Unit
I_{VDDHI}	Total current into V_{DDHI} power line (source)	80	mA
I_{VSS}	Total current out of V_{SS} ground line (sink)	80	
I_{IO}	Output current sunk by any other I/O and control pin	25	
	Output current source by any I/Os and control pin	-25	
$I_{INJ(PIN)}^{(1)}$	Injected current on any pin ⁽²⁾	±5	
$\sum I_{INJ(PIN)}^{(1)}$	Total injected current (sum of all I/O and control pins) ⁽²⁾	±25	

1. $I_{INJ(PIN)}$ must never be exceeded. This is implicitly insured if V_{IN} maximum is respected. If V_{IN} maximum cannot be respected, the injection current must be limited externally to the $I_{INJ(PIN)}$ value. A positive injection is induced by $V_{IN} > V_{DDHI}$ while a negative injection is induced by $V_{IN} < V_{SS}$. For true open-drain pads, there is no positive injection current, and the corresponding V_{IN} maximum must always be respected.
2. When several inputs are submitted to a current injection, the maximum $\sum I_{INJ(PIN)}$ is the absolute sum of the positive and negative injected currents (instantaneous values). These results are based on characterization with $\sum I_{INJ(PIN)}$ maximum current injection on four I/O port pins of the device.



Table 10.3 Thermal Characteristics

Symbol	Rating	Max.	Unit
TSTG	Storage temperature range	-65 to +150	°C
TJ	Maximum junction temperature	150	

10.2 Operating Conditions

10.2.1 General Operating Conditions

Table 10.4 General Operating Conditions

Symbol	Parameter	Conditions	Min	Typ	Max	Unit
f _{MASTER} ⁽¹⁾	Master clock frequency	1.65V ≤ V _{DDHI} ≤ 3.6V	-	16	-	MHz
V _{DDHI}	Standard operating voltage	-	1.65	-	3.6	V
P _D ⁽²⁾	Power dissipation at T _A = 85°C	-	-	-	625	mW
T _A	Temperature range	1.65V ≤ V _{DDHI} ≤ 3.6V	-40	-	85	°C
T _J	Junction temperature range	-40°C ≤ V _{DDHI} ≤ 85°C	-40	-	105	°C

1. f_{MASTER} = f_{CPU}

2. To calculate P_{Dmax}(T_A) use the formula given in thermal characteristics P_{Dmax}=(T_{Jmax} -T_A)/θ_{JA} with T_{Jmax} in this table and θ_{JA} in Table 10.15.

10.2.2 Power-up / Power-down Operating Conditions

Table 10.5 Operating Conditions at Power Up / Down

Symbol	Parameter	Conditions	Min	Typ	Max	Unit
t _{VDDHI}	V _{DDHI} rise time rate		20	-	1300	µs/V
t _{TEMP}	Reset release decay	V _{DDHI} rising	-	1	-	Ms
V _{POR}	Power on reset threshold		1.44	-	1.65 ⁽¹⁾	V
V _{PDR}	Power down reset threshold		1.30	-	1.60 ⁽²⁾	V

1. Tested in production

2. Data based on characterisation results, not tested in production.



10.2.3 Supply Current Characteristic

Table 10.6 Current Consumption(1)

Symbol	Parameter	Conditions	Typ	Max	Unit
I _{DD(CORE)}	Run current for processor core	16MHz master frequency (T _A = -40 °C to 85 °C)	2.8	3.5	mA
I _{DD(LP STATE)}	Supply current in low-power sleep state (which is added to cycle time to obtain desired report rate)	T _A = -40 °C to 25 °C	1	2	uA
		T _A = 85 °C	1.4	3.2	uA
I _{DD(SUSPEND)}	Supply current in <i>suspend</i> state	T _A = -40 °C to 25 °C	0.4	1.2	uA
		T _A = 85 °C	1	2.5	uA

1. Data based on characterisation results, unless otherwise specified.

10.2.4 ProxSense® Current Consumption

The break-down of the consumption from the ProxSense peripheral is shown below.

Table 10.7 ProxSense® Current Consumption(1)

Symbol	ProxSense transmitter (Tx)	ProxSense receiver (Rx)	Typ	Unit
I _{DD(PXS)}	1	1	0.6	mA
	1	4	1.1	mA
	1	10	2.3	mA

1. Data based on characterisation results, unless otherwise specified.

10.2.5 Expected Total Current Consumption Scenarios

The specific parameters configured on varying designs have a great impact on the obtained current consumption. Due to this, the following table is purely illustrative of the expected consumption for similar configurations. The device configurations used below are examples of practical setups expected in applications.



Table 10.8 Total Current Consumption(1)

Symbol	Sensors	Report Rate	Current (Typ)			Unit
			IQS550	IQS572	IQS525	
I _{DD(Total)}	Trackpad ⁽²⁾	10ms	3.75	2.73	1.46	mA
	Trackpad ⁽²⁾	15ms	2.52	1.85	0.99	mA
	Trackpad ⁽²⁾	20ms	1.9	1.38	0.74	mA
	Trackpad ⁽²⁾	40ms	975	690	370	uA
	Trackpad ⁽²⁾	80ms	483	346	185	uA
	Trackpad ⁽²⁾	160ms	243	174	96	uA
	Trackpad ⁽²⁾	320ms	121	89	48	uA
	Trackpad ⁽²⁾	640ms	67	55	26	uA
	ALP ⁽³⁾	80ms	48			uA
	ALP ⁽³⁾	160ms	25			uA
	ALP ⁽³⁾	320ms	13			uA
	ALP ⁽³⁾	640ms	7			uA
	ALP ⁽⁴⁾	80ms	43			uA
	ALP ⁽⁴⁾	160ms	22			uA
	ALP ⁽⁴⁾	320ms	12			uA
	ALP ⁽⁴⁾	640ms	7			uA
	ALP ⁽⁵⁾	80ms	41			uA
	ALP ⁽⁵⁾	160ms	21			uA
	ALP ⁽⁵⁾	320ms	12			uA
	ALP ⁽⁵⁾	640ms	6			uA

1. Based on bench measurements, not characterised
2. Tested with maximum number of sensors active (IQS550 – 15x10 / IQS572 – 9x8 / IQS525 – 5x5); ATI Target of 500 counts; Max number of multi-touches = 2 / default hardware (conversion) settings / 1 finger touch (8mm diameter) active / streaming 27 bytes (XY data and gestures) / I²C pull-ups of 4.7kΩ / V_{DDHI} = 3.3V
3. Tested with ALP channel configured in projected capacitive mode; ATI Target of 500; Alternating Tx's enabled, all Rx's enabled; Event-Mode enabled
4. Tested with ALP channel configured in projected capacitive mode; ATI Target of 500; All Tx's enabled, single Rx's around trackpad enabled; Event-Mode enabled
5. Tested with ALP channel configured in self capacitive mode; ATI Target of 800; single Rx enabled; Event-Mode enabled



10.2.6 I/O Port Pin Characteristics

General characteristics

Subject to general operating conditions for V_{DDHI} and T_A unless otherwise specified. All unused pins must be kept at a fixed voltage: using the output mode of the I/O for example or an external pull-up or pull-down resistor.

Table 10.9 Standard I/O Static Characteristic (1) (2)

Symbol	Parameter	Conditions	Min.	Typ.	Max.	Unit
V_{IL}	Input low level voltage ⁽³⁾	Standard I/Os	$V_{SS}-0.3$	-	$0.3V_{DDHI}$	V
V_{IH}	Input high level voltage ⁽³⁾	Standard I/Os	$0.7 V_{DDHI}$	-	$V_{DDHI} +0.3$	
V_{hys}	Schmitt trigger voltage hysteresis ⁽⁴⁾	Standard I/Os	-	200	-	mV
I_{lkg}	Input leakage current ⁽⁵⁾	$V_{SS} \leq V_{IN} \leq V_{DDHI}$ Standard I/Os	-1	-	1	uA
		$V_{SS} \leq V_{in} \leq V_{REG}^{(6)}$ RX, Tx I/Os	-1	-	1	
R_{PU}	Weak pull-up equivalent resistor ⁽⁷⁾	$V_{IN} = V_{SS}$	30	45	60	kΩ
$C_{IO}^{(8)}$	I/O pin capacitance		-	5	-	pF

- $V_{DDHI} = 3.0\text{ V}$, $T_A = -40\text{ to }85^\circ\text{C}$ unless otherwise specified.
- Not applicable to Rx and Tx pins.
- Data based on characterisation results, not tested in production.
- Hysteresis voltage between Schmitt trigger switching levels. Based on characterization results, not tested.
- The maximum value may be exceeded if negative current is injected on adjacent pins.
- V_{IN} must not exceed V_{REG} value if ProxSense® is enabled, even on port B and D (Tx), $V_{REG} = 1.55\text{V}$.
- R_{PU} pull-up equivalent resistor based on a resistive transistor (corresponding I_{PU} current characteristics)
- Data guaranteed by design, not tested in production



10.2.7 Output Driving Current

Subject to general operating conditions for V_{DDHI} and T_A unless otherwise specified.

Table 10.10 Output Driving Current (high sink ports)

I/O type	Symbol	Parameter Conditions	Conditions	Min.	Max.	Unit
Standard	$V_{OL}^{(1)}$	Output low level voltage for an I/O pin	$I_{IO} = +2mA, V_{DDHI} = 1.8V$	-	0.45	V
			$I_{IO} = +2mA, V_{DDHI} = 3.0V$	-	0.45	
			$I_{IO} = +10mA, V_{DDHI} = 3.0V$	-	0.7	
	$V_{OH}^{(2)}$	Output high level voltage for an I/O pin	$I_{IO} = -1mA, V_{DDHI} = 1.8V$	V_{DDHI}	-	
			$I_{IO} = -1mA, V_{DDHI} = 3.0V$	V_{DDHI}	-	
			$I_{IO} = -10mA, V_{DDHI} = 3.0V$	V_{DDHI}	-	
ProxSense I/O	V_{OL}	Output low level voltage for Tx and Rx ProxSense I/Os	$I_{RX} = TBD$	-	TBD	
	V_{OH}	Output high level voltage for Tx ProxSense I/O	$I_{TX} = 1mA$	1.45	-	
	V_{OH}	Output high level voltage for Rx ProxSense I/O	$I_{PXS_RX} = 0.5mA$	1.35	-	

1. The I_{IO} current sunk must always respect the absolute maximum rating and the sum of I_{IO} (I/O ports and control pins) must not exceed I_{VSS} .
2. The I_{IO} current sourced must always respect the absolute maximum rating and the sum of I_{IO} (I/O ports and control pins) must not exceed I_{VDDHI} .

10.2.8 NRST Pin

The NRST pin input driver is CMOS. A permanent pull-up is present; thus an external component is not needed if NRST is unconnected in the design.

Subject to general operating conditions for V_{DDHI} and T_A unless otherwise specified.



Table 10.11 NRST Pin Characteristics

Symbol	Parameter	Conditions	Min.	Typ.	Max.	Unit
$V_{IL(NRST)}$	NRST Input low level voltage ⁽¹⁾		V_{SS}	-	0.8	V
$V_{IH(NRST)}$	NRST Input high level voltage ⁽¹⁾		1.4	-	V_{DDHI}	
$V_{OL(NRST)}$	NRST Output low level voltage	$I_{OL} = 2\text{mA}$	-	-	$V_{DDHI} - 0.8$	
$R_{PU(NRST)}$	NRST pull-up equivalent resistor ⁽²⁾		30	45	60	k Ω
$V_F(NRST)$	NRST input filtered pulse ⁽³⁾		-	-	50	ns
$t_{OP(NRST)}$	NRST output pulse width		20	-	-	
$V_{NF(NRST)}$	NRST input not filtered pulse ⁽³⁾		300	-	-	

1. Data based on characterization results, not tested in production.
2. The RPU pull-up equivalent resistor is based on a resistive transistor.
3. Data guaranteed by design, not tested in production.

The reset network shown in Figure 10.1 protects the device against parasitic resets. The user must ensure that the level on the NRST pin can go below the V_{IL} max. level specified in Table 10.11. Otherwise the reset is not taken into account internally.

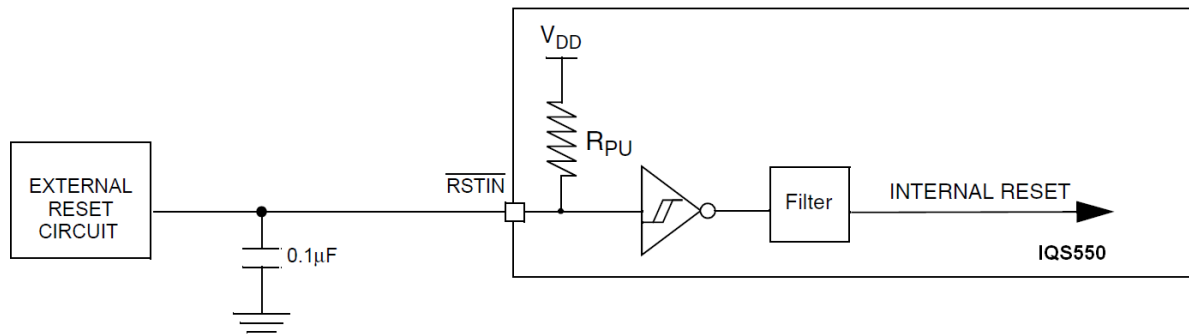

Figure 10.1 Recommended NRST Pin Configuration



10.2.9 I²C Characteristics

Subject to general operating conditions for V_{DDHI} , f_{MASTER} , and T_A unless otherwise specified.

The IQS5xx I²C interface meets the requirements of the Standard I²C communication protocol described in the following table with the restrictions mentioned below.

Table 10.12 I²C Characteristics

Symbol	Parameter	Standard I ² C (100kHz)		Fast I ² C (400kHz)		Unit
		Min ⁽¹⁾	Max ⁽¹⁾	Min ⁽¹⁾	Max ⁽¹⁾	
$t_w(SCLL)$	SCL clock low time	4.7	-	1.3	-	μs
$t_w(SCLH)$	SCL clock high time	4.0	-	0.6	-	μs
$t_{su}(SDA)$	SDA setup time	250	-	100	-	ns
$t_h(SDA)$	SDA data hold time	0 ⁽²⁾	-	0	900 ⁽²⁾	ns
$t_r(SDA)$	SDA rise time	-	1000	-	300	ns
$t_r(SCL)$	SCL rise time	-	1000	-	300	ns
$t_f(SDA)$	SDA fall time	-	300	-	300	ns
$t_f(SCL)$	SCL fall time	-	300	-	300	ns
$t_h(STA)$	START condition hold time	4.0	-	0.6	-	μs
$t_{su}(STA)$	Repeated START condition setup time	4.7	-	0.6	-	μs
$t_{su}(STO)$	STOP condition setup time	4.0	-	0.6	-	μs
C_b	Capacitive load for each bus line	-	400	-	400	pF

1. Data based on protocol requirement, not tested in production

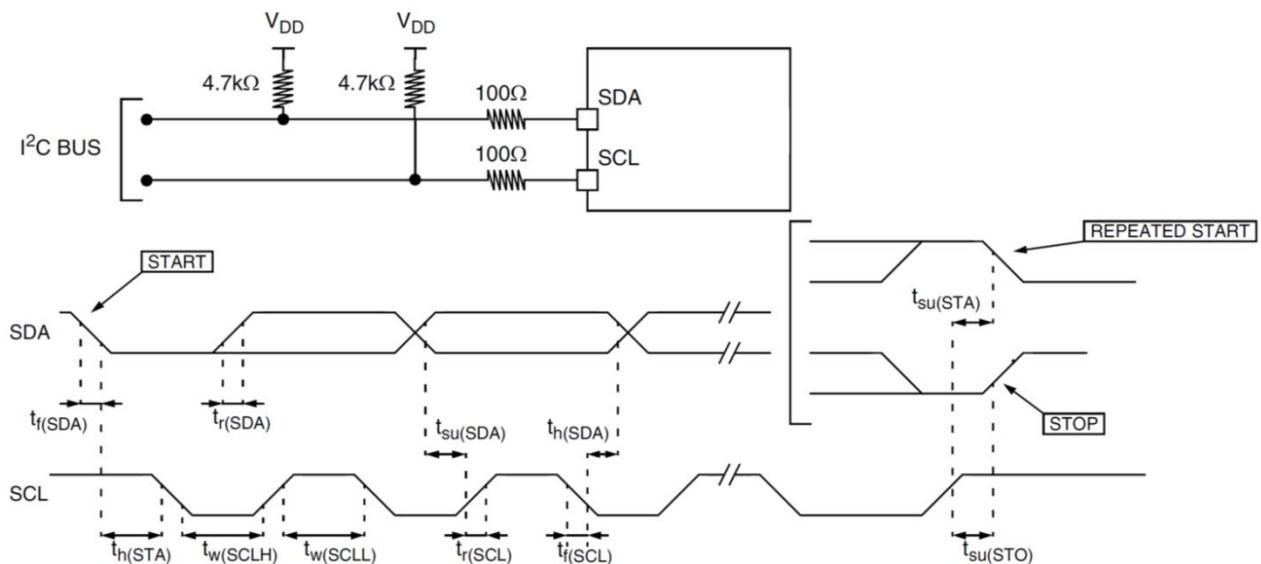

Figure 10.2 Typical Bus Application and Timing Diagram



10.2.10 Package Moisture Sensitivity

Table 10.13 Moisture Sensitivity Level (MSL)

Parameter	IQS550	IQS572	IQS525
Package Moisture Sensitivity Level (MSL)	3	3	3

10.2.11 Electrostatic Discharge (ESD)

Electrostatic discharges (a positive then a negative pulse separated by 1 second) are applied to the pins of each sample according to each pin combination. The sample size depends on the number of supply pins in the device (3 parts*(n+1) supply pin). Two models can be simulated: human body model and charge device model. This test conforms to the JESD22-A114A/A115A standard.

Table 10.14 ESD Absolute Maximum Ratings

Symbol	Ratings	Conditions	Max Value	Unit
V _{ESD(HBM)}	Electrostatic discharge voltage (human body model)	T _A = +25 °C	2000 ⁽²⁾	V
V _{ESD(CDM)}	Electrostatic discharge voltage (charge device model)		1000	

1. Data based on characterisation results, not tested in production.
2. Device sustained up to 3000 V during ESD trials.

10.2.12 Thermal Characteristics

The maximum chip junction temperature (T_{Jmax}) must never exceed the values given in Table 10.4.

The maximum chip-junction temperature, T_{Jmax}, in degrees Celsius, may be calculated using the following equation:

$$T_{Jmax} = T_{Amax} + (P_{Dmax} \times \theta_{JA})$$

Where:

- T_{Amax} is the maximum ambient temperature in °C
- θ_{JA} is the package junction-to-ambient thermal resistance in °C/W
- P_{Dmax} is the sum of P_{INTmax} and P_{I/Omax} (P_{Dmax} = P_{INTmax} + P_{I/Omax})
- P_{INTmax} is the product of I_{DD} and V_{DDHI}, expressed in watts. This is the maximum chip internal power.
- P_{I/Omax} represents the maximum power dissipation on output pins where:
 $P_{I/Omax} = \sum (V_{OL} \cdot I_{OL}) + \sum ((V_{DDHI} - V_{OH}) \cdot I_{OH})$, taking into account the actual V_{OL}/I_{OL} and V_{OH}/I_{OH} of the I/Os at low and high level in the application.



Table 10.15 Thermal Characteristics(1)

Symbol	Parameter	Value	Unit
Θ_{JA}	Thermal resistance junction ambient	32	°C/W

1. Thermal resistances are based on JEDEC JESD51-2 with 4-layer PCB in a natural convection environment.

10.2.13 ProxSense Electrical Characteristics

Table 10.16 Rx / Tx Characteristics

Symbol	Parameter	Conditions	IQS550	IQS572	IQS525	Unit
C_{RG}	Rx capacitance to ground		60			pF
C_{TG}	Tx capacitance to ground		60	60	40	pF
C_M	Mutual capacitance between Rx and Tx		4			pF
R_{rx}	Total Rx resistance	16MHz Prox Clock	2			kΩ
		4MHz Prox Clock	20			kΩ
R_{tx}	Total Tx resistance	16MHz Prox Clock	2			kΩ
		4MHz Prox Clock	20			kΩ

Data based on characterisation results, not tested in production.



11 Mechanical Dimensions

11.1 IQS550 QFN(7x7)-48 Mechanical Dimensions

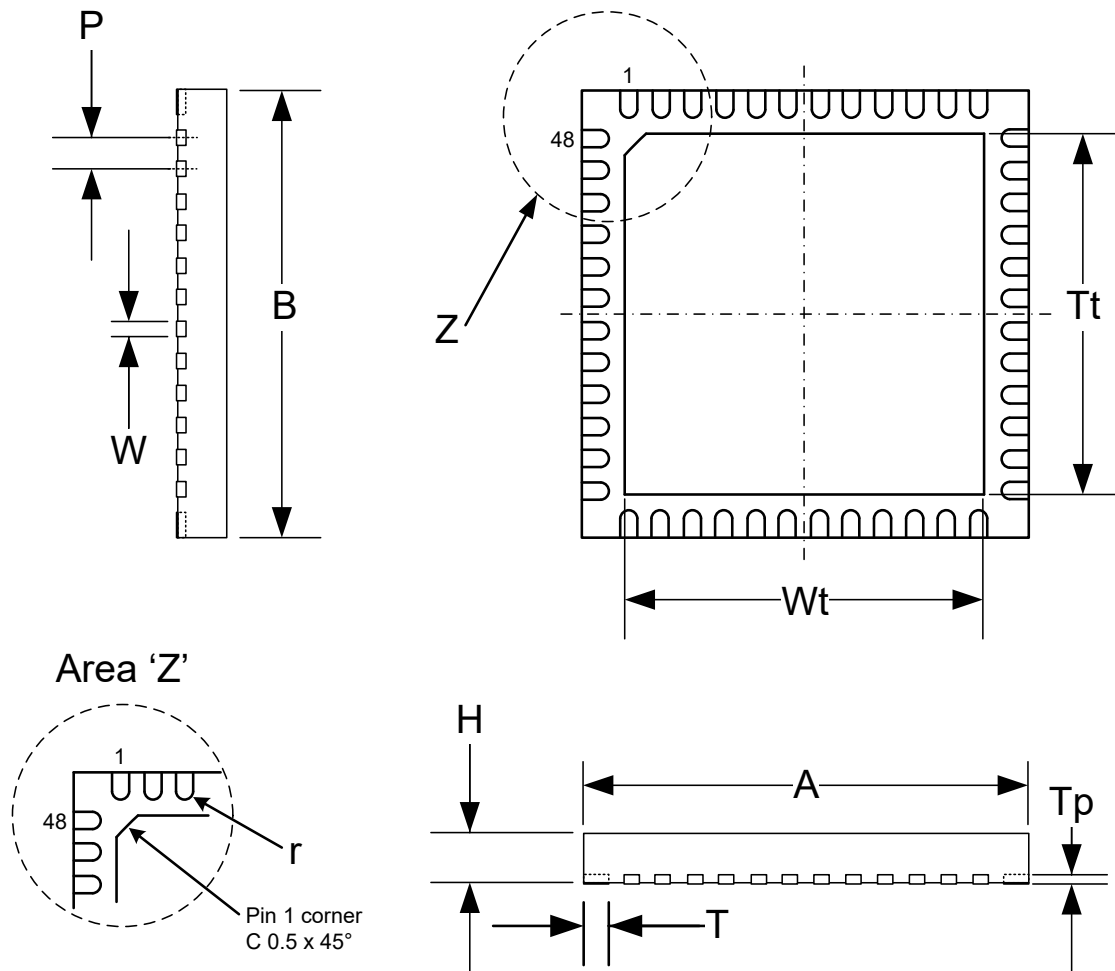

Figure 11.1 QFN(7x7)-48 Package

Table 11.1 Dimensions from Figure 11.1

Label	Dimension (mm)			Label	Dimension (mm)		
	Min	Typical	Max		Min	Typical	Max
P		0.500		H	0.500	0.550	0.600
T	0.300	0.400	0.500	A / B	6.900	7.00	7.100
W	0.200	0.250	0.300	Tp		0.152	
Tt	5.500	5.600	5.700	r		0.125	
Wt	5.400	5.500	5.600				

11.2 IQS550 Landing Pad Layout

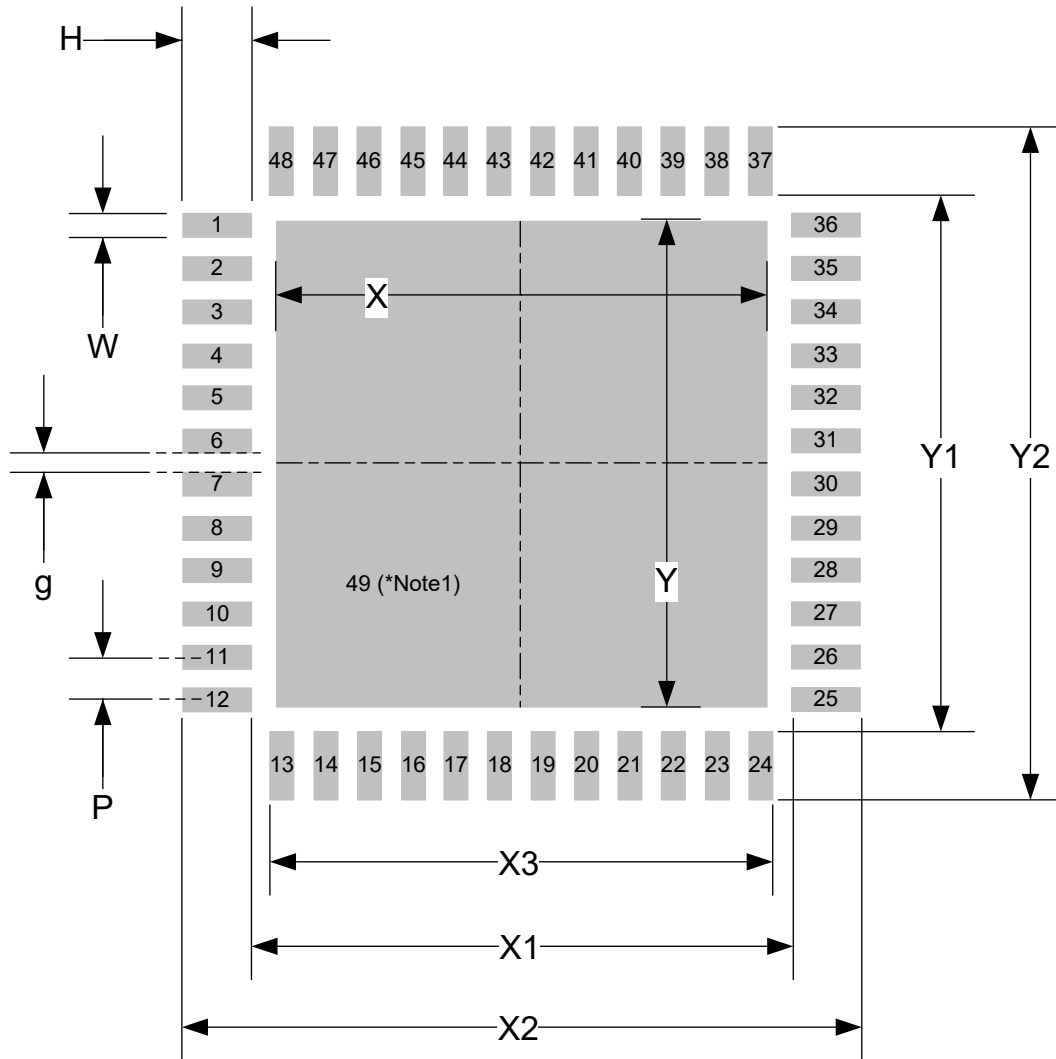

Figure 11.2 QFN(7x7)-48 Footprint

Table 11.2 Dimensions from Figure 11.2

Label	Dimension (mm)	Label	Dimension (mm)
X	5.60	Y2	7.30
X1	6.20	H	0.55
X2	7.30	W	0.30
X3	5.80	g	0.20
Y	5.60	P	0.50
Y1	6.20		

*Note1: It is recommended to connect and solder this back-side pad to PCB ground.



11.3 IQS572/IQS525 QFN(4x4)-28 Mechanical Dimensions

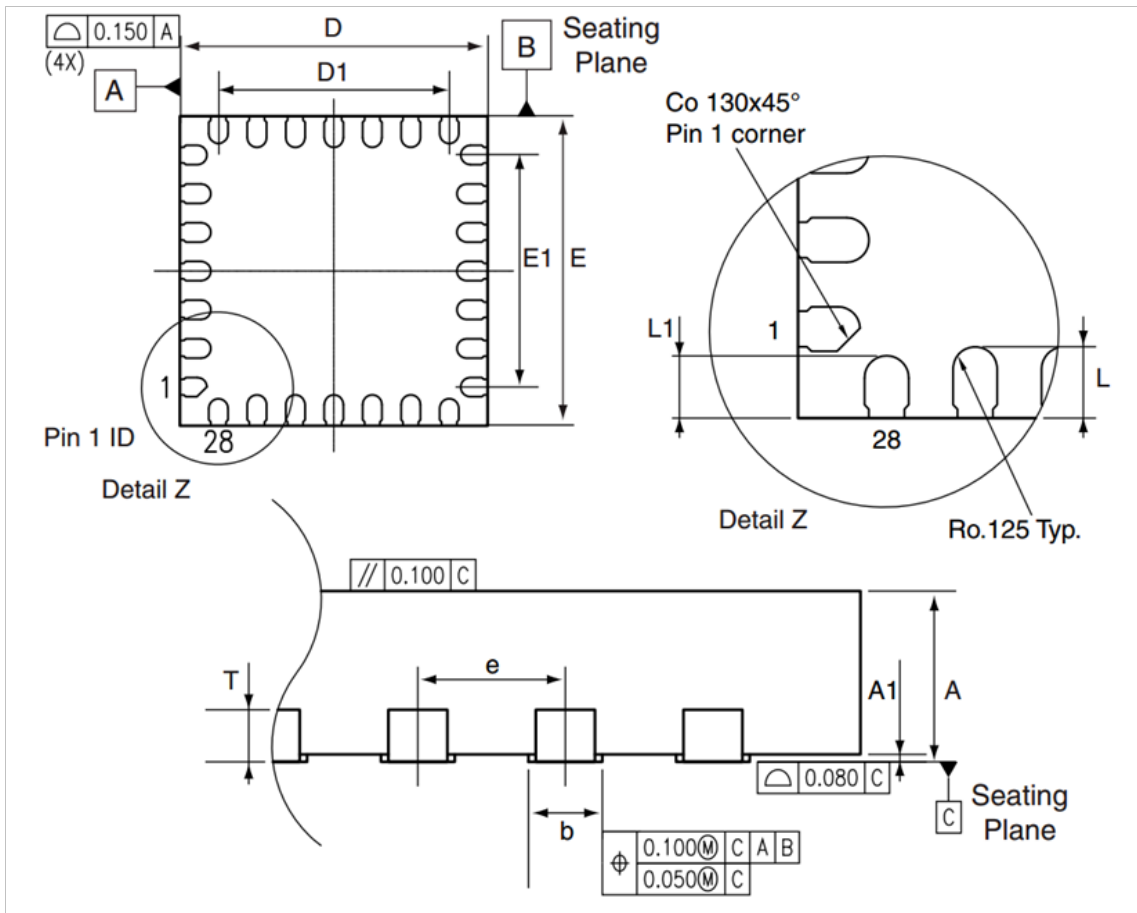

Figure 11.3 QFN(4x4)-28 Package

Table 11.3 Dimensions from Figure 11.3

Label	Dimension (mm)			Label	Dimension (mm)		
	Min	Typical	Max		Min	Typical	Max
A	0.5	0.55	0.6	L	0.3	0.4	0.5
A1	-0.05	0	0.05	L1	0.25	0.35	0.45
D	3.9	4.0	4.1	T		0.152	
D1	2.9	3.0	3.1	b	0.2	0.25	0.3
E	3.9	4.0	4.1	e		0.5	
E1	2.9	3.0	3.1				



11.4 IQS572/IQS525 Landing Pad Layout

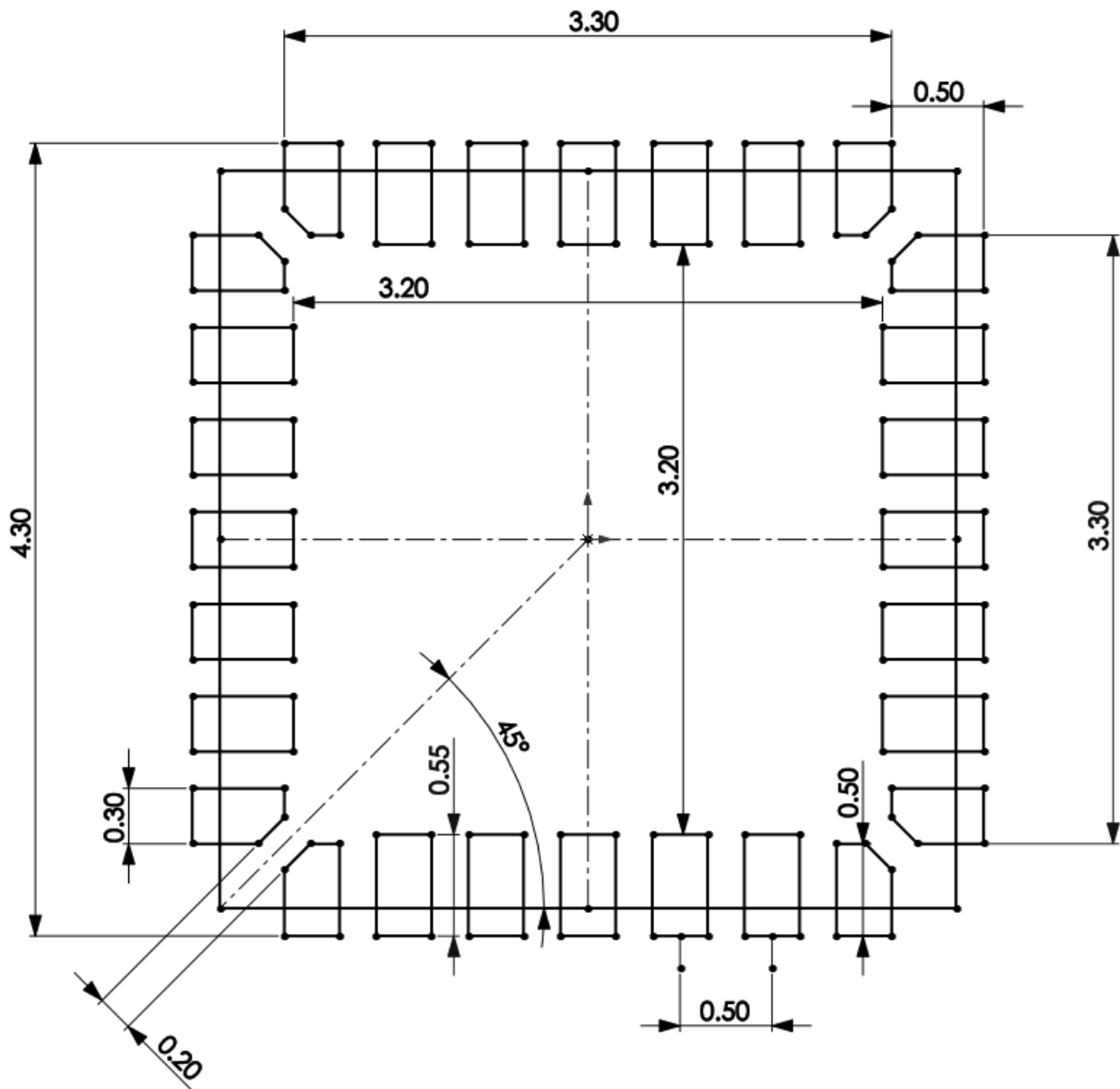

Figure 11.4 QFN(4x4)-28 Footprint (dimensions in millimetres)

12 Packaging Information

12.1 Tape Specification

The IQS5xx products come packaged in a carrier tape on a reel. The carrier tape has a leader and trailer section where no products are populated. A 400mm (min) section at the start of the carrier tape is empty (leader part). The cover tape starts in this leader part and covers a 100mm (min) of carrier tape that has no products. From there the products are consecutively populated in the carrier tape. The trailer of 160mm (min) has no products.

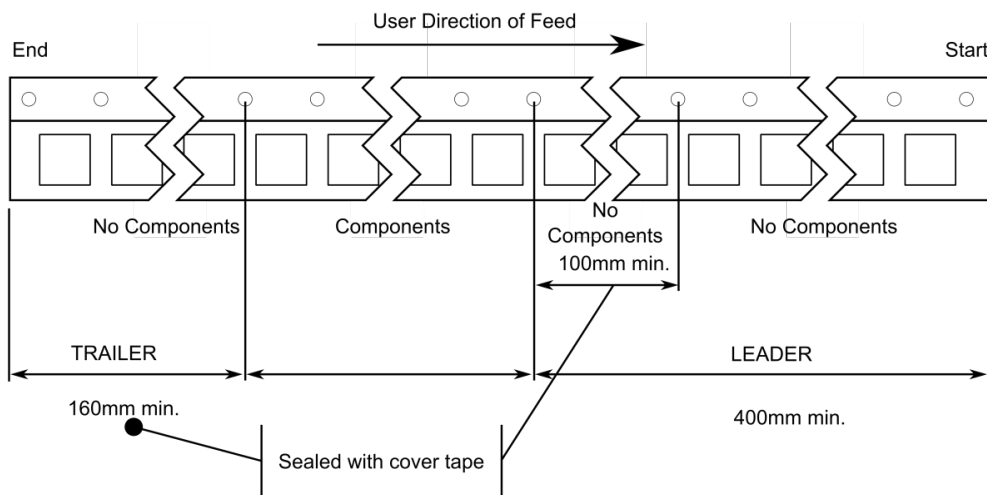

Figure 12.1 Representation of Leader and Trailer for the Carrier Tape

Table 12.1 Tape Dimensions

Description	Measurement (mm)		
	IQS550	IQS572	IQS525
Tape width	16	12	12
Part pitch	12	8	8
Sprocket hole diameter	1.5	2	2
Sprocket hole pitch	4	4	4
Cavity length	7.2	5.3	5.3
Cavity width	7.2	5.3	5.3
Cavity depth	1.2	1.1	1.1
Cover tape width	13	9.5	9.5

Please note: Cover tape does not cover the sprocket holes.

12.1.1 IQS550 Tape Description

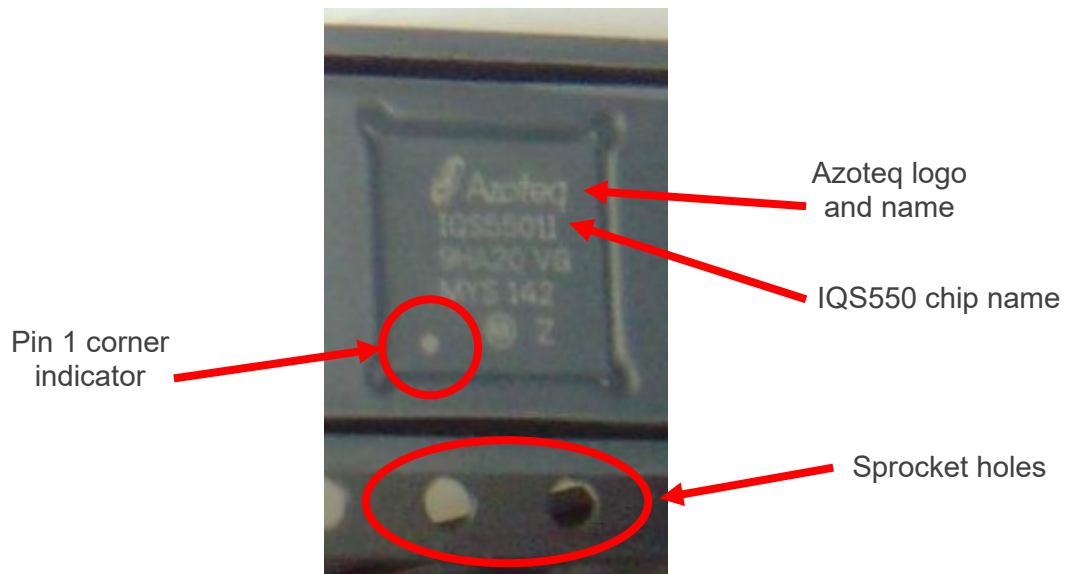

Figure 12.2 IQS550 QFN48-7x7 Package in Carrier Tape Example

The IQS550 is packed in a carrier tape as shown above and placed on the reel. It fits in a long carrier tape that is moulded specifically for this product and a removable see-through cover tape is placed over. This cover can be peeled off and the product taken out of the tape with a pick-and-place machine. The Pin 1 corner indicator is closest to a side facing the sprocket holes in the carrier tape as illustrated.

12.1.2 IQS572 and IQS525 Tape Description

The IQS525 & IQS572 share the same tape and reel details, with an example of the IQS525 tape provided here.

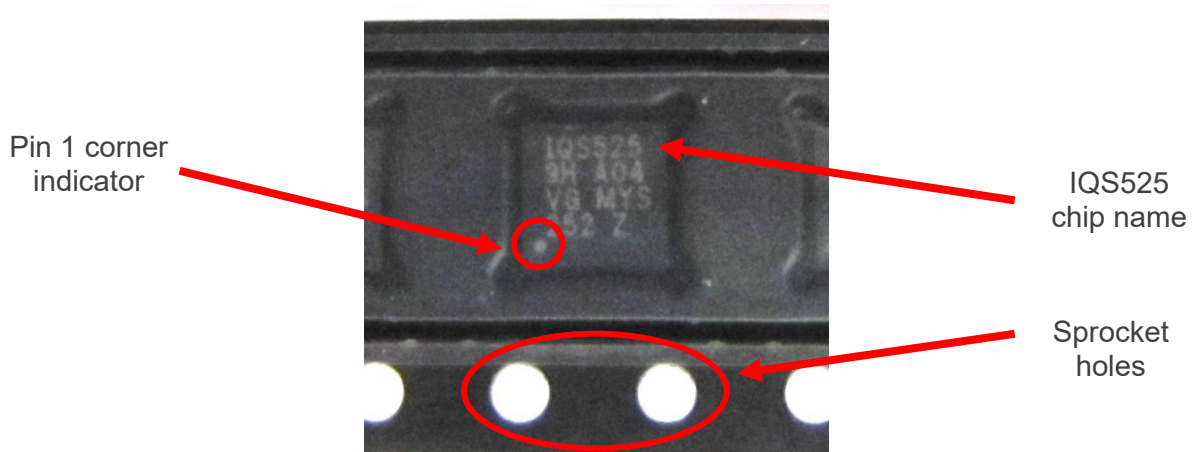

Figure 12.3 IQS525 QFN28-4x4 Package in Carrier Tape Example

Again, the Pin 1 corner indicator is closest the side facing the sprocket holes in the carrier tape as illustrated.



12.2 Reel Specification

The reel is made from a high impact PS material. The physical dimensions are illustrated in the table and figure below.

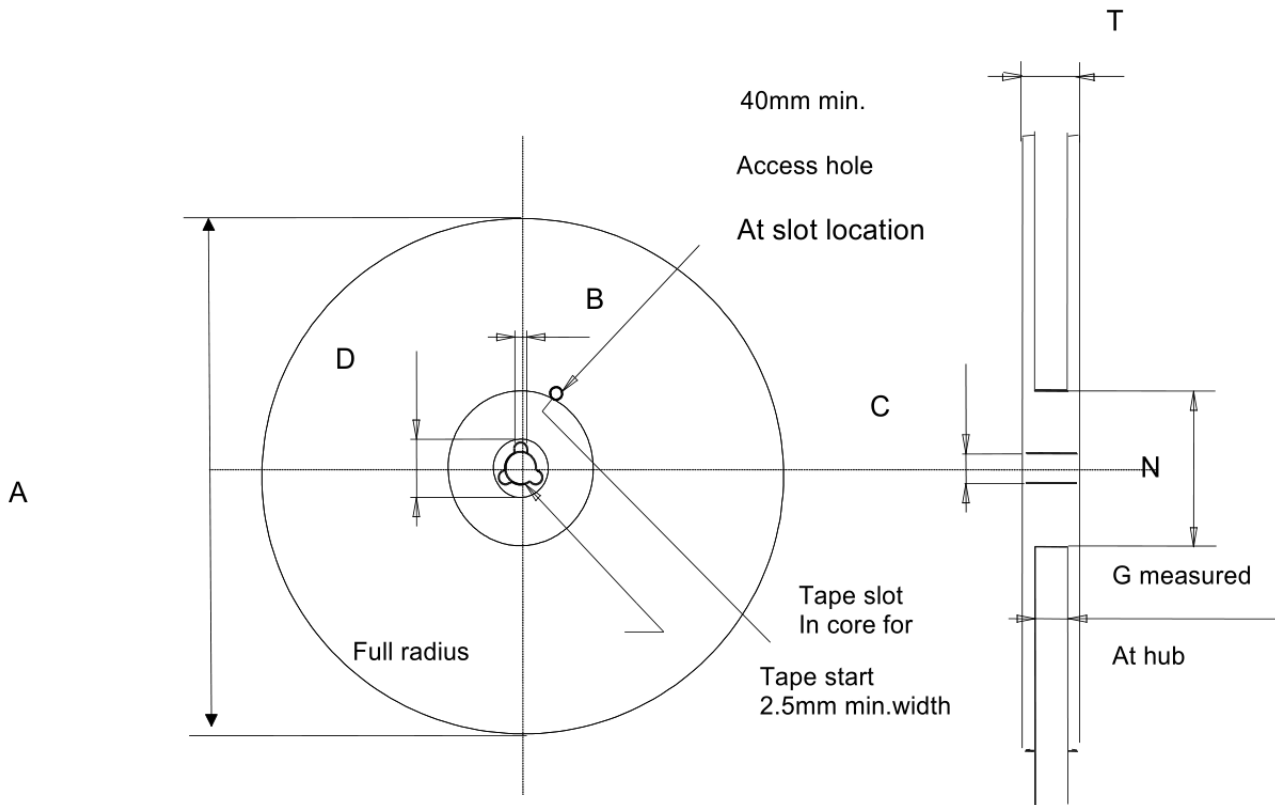

Figure 12.4 Reel Dimensions: Front and Side View

Table 12.2 Reel Dimensions

Dimension	Value (in mm)		
	IQS550	IQS572	IQS525
A	330 (max)	330 (max)	330 (max)
B	1.5 (min)	1.5 (min)	1.5 (min)
C	13 ±0.2	13 ±0.2	13 ±0.2
D	20.2 (min)	20.2 (min)	20.2 (min)
N	60	60	60
G	16.4 + 2/-0	12.4 + 2/-0mm	12.4 + 2/-0mm
T	22.4 (max)	18.4mm (max)	18.4mm (max)

Note: The reel could also have additional cut-outs not illustrated in the figure



12.2.1 Dry Packing

The IQS5xx is specifically dry packed to protect them from moisture absorption while shipping/storing which has a large effect on the quality and reliability of the IQS5xx after soldering. To improve the quality and reliability of soldering joints, it is advised to bake the IQS5xx before reflow soldering.

Below is a flow diagram which shows how Azoteq aims to minimise moisture absorption during shipping and storage. On the right side is a flow diagram specific for the customer to consult whether baking is needed.

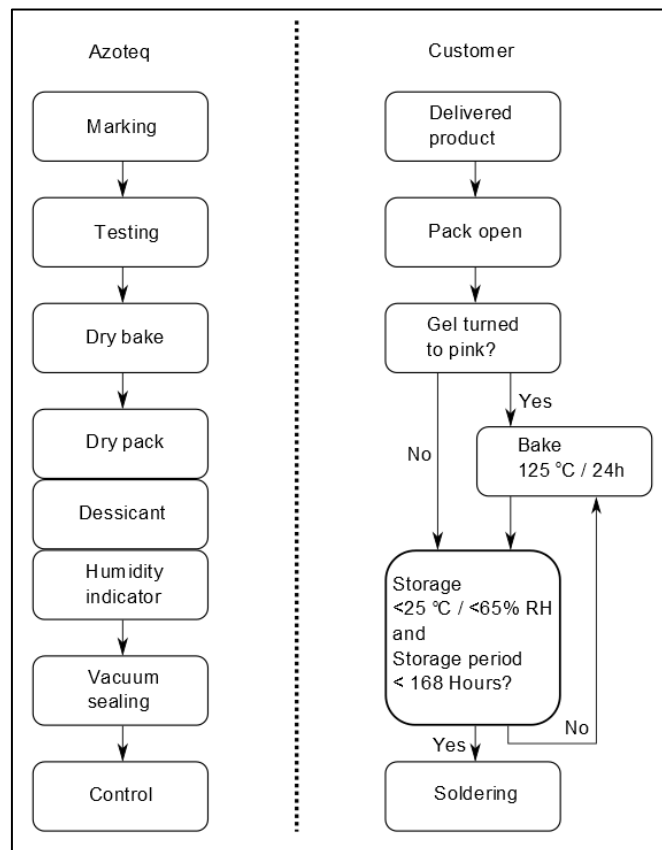

Figure 12.5 Moisture Absorption Control Method / Guide

The flow diagram above informs the customer whether the baking process is needed. When opening the dry pack consult the humidity indicator (gel) inside the pack. If it turned pink, the product must be baked. If the gel is not pink, within the specified period there is no need for baking, as long as the humidity and temperature conditions are met.

12.2.2 Baking

The IQS5xx is packed in a tape and reel and can thus not be baked. It must first be transferred to a non-metal tube or tray, for example a glass tray. This is placed in an oven and baked according to the IPC/JEDEC J-STD-033C MSL specification. A picture of this baking method is shown below.

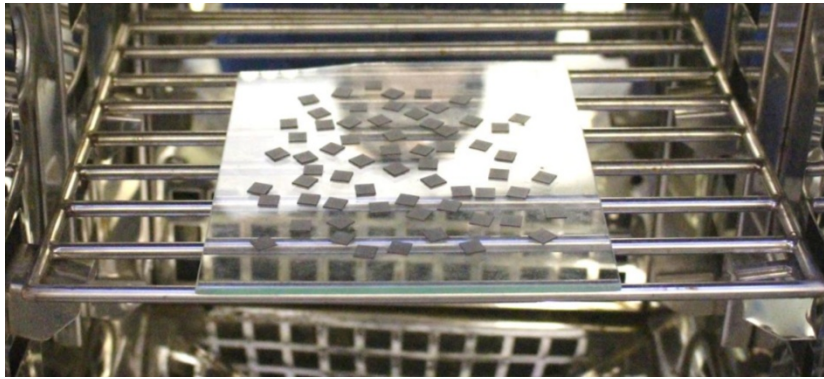

Figure 12.6 IQS550 Baking Example

Take the IQS5xx out of the carrier tape and place on for example a glass sheet. Ensure all the IQS5xx's are turned top side up and not lying on top of each other. Bake the product for 24 hours at 125 °C. Remove from oven and let cool for about 1 hour before handling.

12.3 Handling of the IQS5xx

When handling the IQS5xx product, ESD (Electrostatic discharge) must be avoided as far as possible. Make sure all equipment and personnel are grounded to avoid static build-up. Machines should be grounded, and personnel should wear grounding straps.

12.4 Reflow for IQS5xx

When soldering the IQS5xx to a board, the correct temperature curve must be followed to ensure good soldering joints and to avoid damaging the chip due to high temperatures.

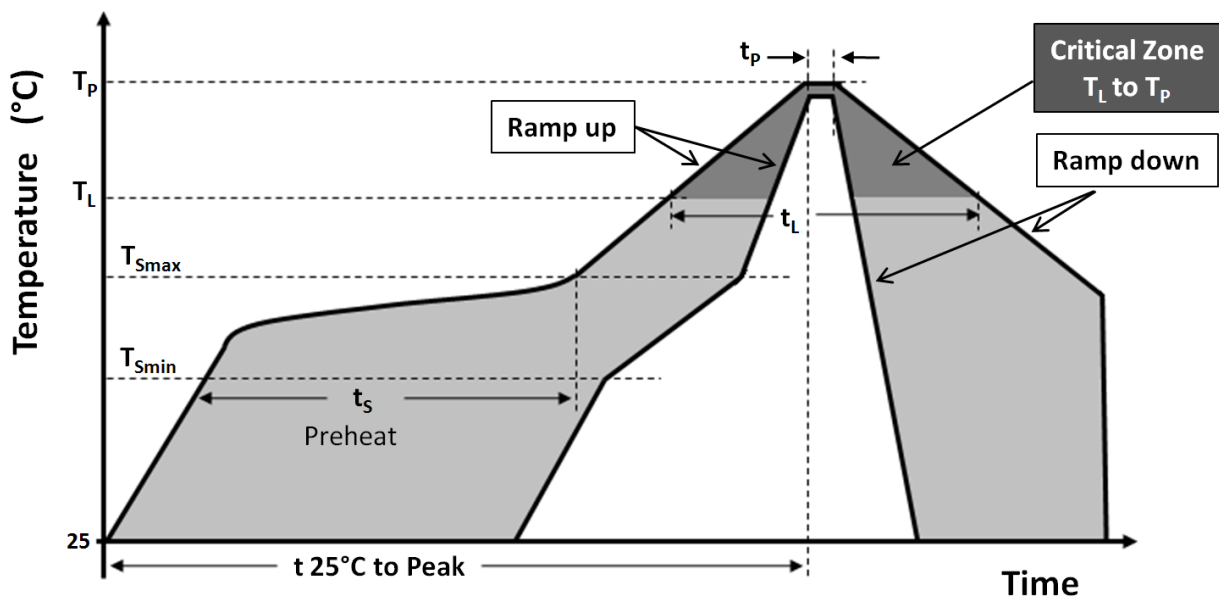

Figure 12.7 Reflow Temperature Curve for the IQS5xx



The figure above shows the temperature profile to be used when soldering the IQS5xx onto a board. This is according to the JEDEC (J-STD-020D.1) standard lead-free reflow profile.

Table 12.3 JEDEC Standard Lead-Free Reflow Profile

Symbol	Description	Value
T_{Smax} to T_P	Average ramp-up rate	3 °C/second max
T_{Smin}	Temperature min	150 °C
T_{Smax}	Temperature max	200 °C
t_s	Preheat time	60 – 120 seconds
T_L	Temperature	217 °C
t_L	Time maintained above temperature T_L	60 – 150 seconds
T_P	Peak/classification temperature	260 °C
t_P	Time within 5 °C of actual peak temperature (T_P)	30 seconds
	Ramp-down rate	6 °C/second max
t_{25C} to t_P	Time: 25 °C to peak temperature	8 minutes max

All temperatures refer to topside of the package, measured on the body surface.



13 Device Marking

13.1 IQS550 Marking

Up till June 2017	June 2017 → onwards																																																																		
<table border="0"> <tr><td>A</td><td>=</td><td>IC Name</td></tr> <tr><td>B</td><td>=</td><td>Assembly Plant (e.g. GH)</td></tr> <tr><td>C</td><td>=</td><td><i>Internal use</i></td></tr> <tr><td>D</td><td>=</td><td><i>Internal use</i></td></tr> <tr><td>E</td><td>=</td><td>Country of Origin</td></tr> <tr><td>F</td><td>=</td><td>Assembly Year (Y)</td></tr> <tr><td>G</td><td>=</td><td>Assembly Week (WW)</td></tr> <tr><td>H</td><td>=</td><td>Dot – Pin1 reference</td></tr> <tr><td>I</td><td>=</td><td>2nd Level Inter-Connect (e3)</td></tr> <tr><td>J</td><td>=</td><td>Design Revision</td></tr> </table>	A	=	IC Name	B	=	Assembly Plant (e.g. GH)	C	=	<i>Internal use</i>	D	=	<i>Internal use</i>	E	=	Country of Origin	F	=	Assembly Year (Y)	G	=	Assembly Week (WW)	H	=	Dot – Pin1 reference	I	=	2 nd Level Inter-Connect (e3)	J	=	Design Revision	<table border="0"> <tr><td>A</td><td>=</td><td>IC Name</td></tr> <tr><td>B</td><td>=</td><td>Assembly Plant (e.g. GQ)</td></tr> <tr><td>C</td><td>=</td><td>Internal use</td></tr> <tr><td>D</td><td>=</td><td>Internal use</td></tr> <tr><td>E</td><td>=</td><td>Internal use</td></tr> <tr><td>F</td><td>=</td><td>Country of Origin</td></tr> <tr><td>G</td><td>=</td><td>Internal use</td></tr> <tr><td>H</td><td>=</td><td>Assembly Year (Y)</td></tr> <tr><td>I</td><td>=</td><td>Assembly Week (WW)</td></tr> <tr><td>J</td><td>=</td><td>Dot – Pin1 reference</td></tr> <tr><td>K</td><td>=</td><td>2nd Level Inter-Connect (e3)</td></tr> <tr><td>L</td><td>=</td><td>Design Revision</td></tr> </table>	A	=	IC Name	B	=	Assembly Plant (e.g. GQ)	C	=	Internal use	D	=	Internal use	E	=	Internal use	F	=	Country of Origin	G	=	Internal use	H	=	Assembly Year (Y)	I	=	Assembly Week (WW)	J	=	Dot – Pin1 reference	K	=	2 nd Level Inter-Connect (e3)	L	=	Design Revision
A	=	IC Name																																																																	
B	=	Assembly Plant (e.g. GH)																																																																	
C	=	<i>Internal use</i>																																																																	
D	=	<i>Internal use</i>																																																																	
E	=	Country of Origin																																																																	
F	=	Assembly Year (Y)																																																																	
G	=	Assembly Week (WW)																																																																	
H	=	Dot – Pin1 reference																																																																	
I	=	2 nd Level Inter-Connect (e3)																																																																	
J	=	Design Revision																																																																	
A	=	IC Name																																																																	
B	=	Assembly Plant (e.g. GQ)																																																																	
C	=	Internal use																																																																	
D	=	Internal use																																																																	
E	=	Internal use																																																																	
F	=	Country of Origin																																																																	
G	=	Internal use																																																																	
H	=	Assembly Year (Y)																																																																	
I	=	Assembly Week (WW)																																																																	
J	=	Dot – Pin1 reference																																																																	
K	=	2 nd Level Inter-Connect (e3)																																																																	
L	=	Design Revision																																																																	



13.2 IQS572/IQS525 Marking

Up till July 2017	July 2017 → onwards
<p>A = IC Name</p> <p>B = Assembly Plant (e.g. GH)</p> <p>C = Internal use</p> <p>D = Internal use</p> <p>E = Country of Origin</p> <p>F = Assembly Year (Y)</p> <p>G = Assembly Week (WW)</p> <p>H = Additional Information including Design Revision Code</p> <p>I = Dot – Pin1 reference</p>	<p>A = IC Name</p> <p>B = Assembly Plant (e.g. GQ)</p> <p>C = Internal use</p> <p>D = Internal use</p> <p>E = Internal use</p> <p>F = Country of Origin</p> <p>G = Additional Information including Design Revision Code</p> <p>H = Dot – Pin1 reference</p> <p>I = Assembly Year (Y)</p> <p>J = Assembly Week (WW)</p>



14 Ordering Information

Order quantities will be subject to multiples of full reels. For large orders, Azoteq can provide custom configured devices.

14.1 IQS550 Ordering

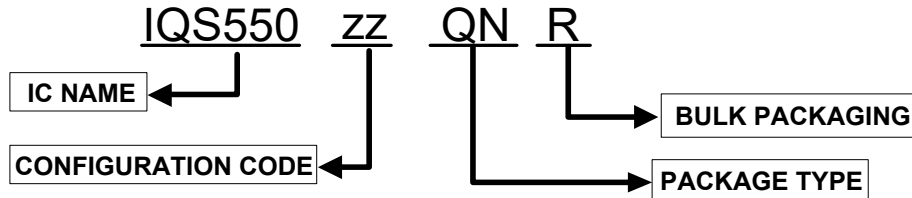

IC NAME	IQS550	=	IQS550
CONFIGURATION CODE	BL	=	Bootloader (ready for application firmware programming, B000 firmware NOT pre-loaded)
PACKAGE TYPE	QN	=	QFN(7x7)-48
BULK PACKAGING	R	=	Reel (2500pcs/reel)

14.2 IQS572 Ordering

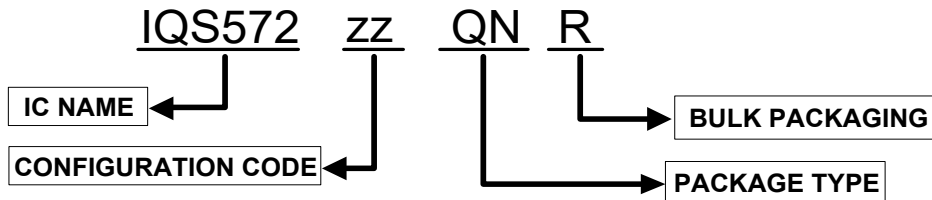

IC NAME	IQS572	=	IQS572
CONFIGURATION CODE	BL	=	Bootloader (ready for application firmware programming, B000 firmware NOT pre-loaded)
PACKAGE TYPE	QN	=	QFN(4x4)-28
BULK PACKAGING	R	=	Reel (3000pcs/reel)

14.3 IQS525 Ordering

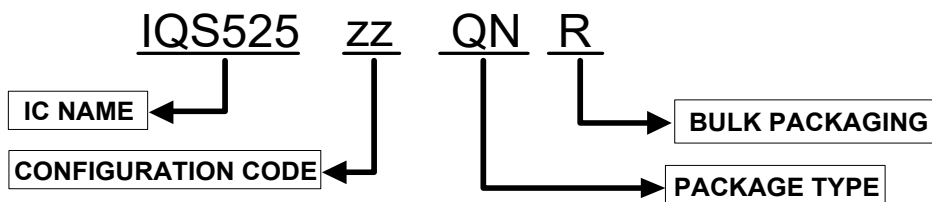

IC NAME	IQS525	=	IQS525
CONFIGURATION CODE	BL	=	Bootloader (ready for application firmware programming, B000 firmware NOT pre-loaded)
PACKAGE TYPE	QN	=	QFN(4x4)-28
BULK PACKAGING	R	=	Reel (3000pcs/reel)



15 Changes:

Release v1.00

- > IQS5xx-B000 datasheet released

Release v1.01

- > Added 'Minimum count Re-ATI delta' to memory map, and updated Section 3.7.2.
- > Updated links (Sections 4.3 and 8.8.2)

Release v2.00

- > Updated wake pin functionality and changed terminology from wake to switch input: Updated section 7.3.2 and 8.8.1, added SWITCH_STATE bit, added SW_INPUT_EVENT bit, Added section 7.11
- > Added export file version: Updated Section 7.1 and memory map
- > Updated Note 2 in Table 10.8 (525 setup added and ATI target fixed)
- > Fixed heading of Table 1.1
- > Updated Figure 11.4
- > Updated RxToTx register to include IQS572 (memory map also updated), and updated Section 5.1.4
- > Added Section 7.9 and 7.10
- > Updated Section 8.8.1 with updated trackpad event definition
- > Added tap location details to Section 6.1
- > Removed manual device setup description and startup flow diagram from Section 7.2
- > Updated overview diagrams and circuit diagrams (removed program interface on PGM and NRST, and updated SW_IN pin)

Release v2.01

- > Corrected Figure 11.4 title
- > Corrected bit 2 definition in *Single Finger Gesture* register (0x06B7) – Updated Table 8.1 and Section 8.10.21
- > Fixed bit 2 description in Section 8.10.9
- > Added updated IC markings in Section 13.1 and 13.2
- > Updated description of RDY functionality during forced comms in Section 8.8.2 and Figure 8.4
- > Updated document template/styles



	USA	Asia	South Africa
Physical Address	11940 Jollyville Suite 120-S Austin TX 78750 USA	Room 501A, Block A, T-Share International Centre, Taoyuan Road, Nanshan District, Shenzhen, Guangdong, PRC	1 Bergsig Avenue Paarl 7646 South Africa
Postal Address	11940 Jollyville Suite 120-S Austin TX 78750 USA	Room 501A, Block A, T-Share International Centre, Taoyuan Road, Nanshan District, Shenzhen, Guangdong, PRC	PO Box 3534 Paarl 7620 South Africa
Tel	+1 512 538 1995	+86 755 8303 5294 ext 808	+27 21 863 0033
Email	info@azoteq.com	info@azoteq.com	info@azoteq.com

Visit www.azoteq.com
for a list of distributors and worldwide representation.

Patents as listed on www.azoteq.com/patents-trademarks/ may relate to the device or usage of the device.

Azoteq®, Crystal Driver , IQ Switch®, ProxSense®, ProxFusion®, LightSense™, SwipeSwitch™, and the  logo are trademarks of Azoteq.







The information in this Datasheet is believed to be accurate at the time of publication. Azoteq uses reasonable effort to maintain the information up-to-date and accurate, but does not warrant the accuracy, completeness or reliability of the information contained herein. All content and information are provided on an "as is" basis only, without any representations or warranties, express or implied, of any kind, including representations about the suitability of these products or information for any purpose. Azoteq disclaims all warranties and conditions with regard to these products and information, including but not limited to all implied warranties and conditions of merchantability, fitness for a particular purpose, title and non-infringement of any third party intellectual property rights. Azoteq assumes no liability for any damages or injury arising from any use of the information or the product or caused by, without limitation, failure of performance, error, omission, interruption, defect, delay in operation or transmission, even if Azoteq has been advised of the possibility of such damages. The applications mentioned herein are used solely for the purpose of illustration and Azoteq makes no warranty or representation that such applications will be suitable without further modification, nor recommends the use of its products for application that may present a risk to human life due to malfunction or otherwise. Azoteq products are not authorized for use as critical components in life support devices or systems. No licenses to patents are granted, implicitly, express or implied, by estoppel or otherwise, under any intellectual property rights. In the event that any of the abovementioned limitations or exclusions does not apply, it is agreed that Azoteq's total liability for all losses, damages and causes of action (in contract, tort (including without limitation, negligence) or otherwise) will not exceed the amount already paid by the customer for the products. Azoteq reserves the right to alter its products, to make corrections, deletions, modifications, enhancements, improvements and other changes to the content and information, its products, programs and services at any time or to move or discontinue any contents, products, programs or services without prior notification. For the most up-to-date information and binding Terms and Conditions please refer to www.azoteq.com.

Looking for pricing, stock, or lifecycle information?

Click below to explore more details on WIN SOURCE:

-  [View IQS572-BL-QNR on WIN SOURCE](#)
-  [Azoteq \(Pty\) Ltd Information](#)

Optimize Your Supply Chain with WIN SOURCE Solutions

-  Global Sourcing Solution
-  Obsolete Management
-  Cost Control Management
-  Shortage Management
-  Alternative Solution
-  Excess Inventory Management