



**THE DATASHEET OF
MAX22707AUB+**



Low Power, Precision Zero Crossing Detector

MAX22707

Product Highlights

- Precision Zero Crossing Detection
 - Integrated Zero Crossing Detection with $\pm 1\%$ Accuracy
 - High Frequency Noise Filter
 - 4th Order Low-Pass Filter (LPF)
 - 4th Order Band-Pass Filter (BPF)
- Configurability for Ease of Use
 - User Selectable Filter Configuration (LPF or BPF)
 - Selectable Input Frequency
 - Power Saving Stand-By Mode
 - Programmable DC Averaging Timer
- Saves PCB Space and Bill of Materials (BOM) Cost
 - No External Precision Filter Capacitor Required
 - 10-Pin μ MAX package 3mm x 3mm

- AC Phase Detection

The integrated solution with user selectable filter configuration improves zero-crossing detection with $\pm 1\%$ accuracy. The available filter types are the fourth order BPF and LPF. The DC averaging filter capacitor function is used for the LPF.
- Flexible Zero Crossing Detection

The MAX22707 supports two basic input frequencies which depend on the filter type. If the band-pass is selected, the frequency selection mode control pin (MC) is used to choose between 50Hz and 60Hz. If the low-pass is selected, the same pin is used to choose between 50/60Hz and 100/120Hz signal band. To select between sine and rectified inputs, the rectified select pin (RS) is used.

For more product highlights, see [Detailed Description](#).

Key Applications

- Industrial Lighting Dimming

The integrated filters eliminate the flicker and provide up to 75% reduction in PCB footprint compared to a discrete solution requiring multiple amplifiers, comparators, and precision filter capacitors and resistors. The MAX22707 features a low-power, precision analog filter based on the switched-capacitor technology designed for precision filtering of AC input noise. The device requires only a simple external input network preceding the AC inputs and no additional external components for the filters. The MAX22707 is rated for the operation at ambient temperatures of -40°C to $+125^{\circ}\text{C}$.

Pin Description

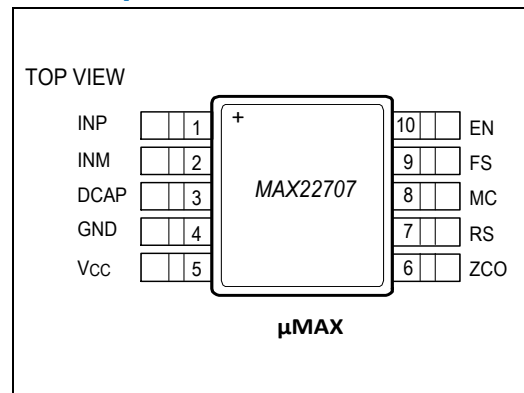

[Ordering Information](#) appears at end of data sheet.

Simplified Application Diagram

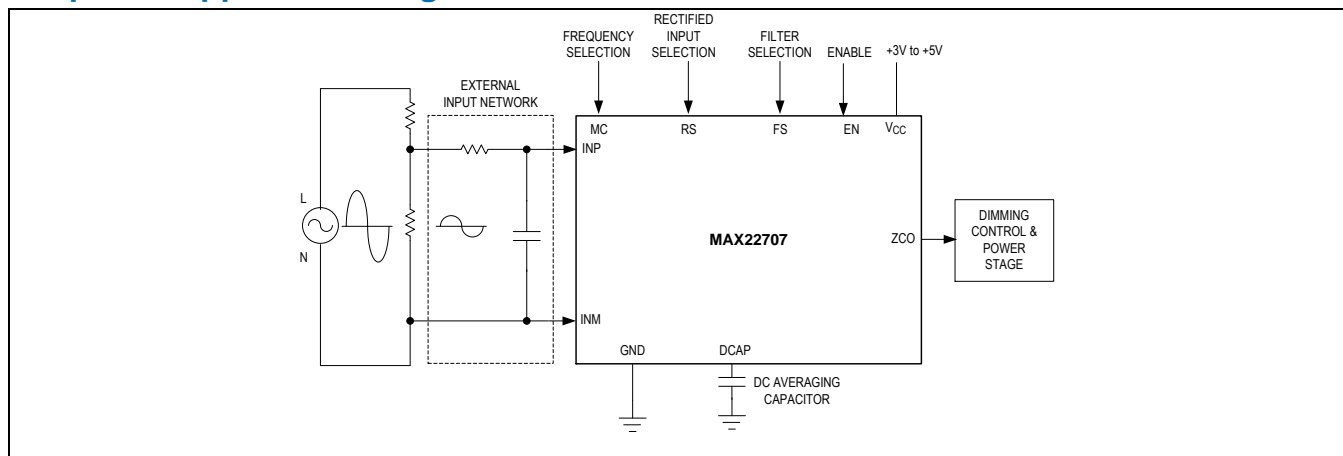

Absolute Maximum Ratings

V_{CC} to GND	-0.3V to +6V
ZCO, DCAP to GND.....	-0.3V to +6V
EN, RS, MC, FS to GND.....	-0.3V to Min(+6V, ($V_{CC} + 0.3V$))V
INP, INM to GND	-($V_{CC} + 0.3$) V to ($V_{CC} + 0.3$)V
Short Circuit Duration (ZCO to GND)	Continuous
Continuous Current (INP, INM to GND)	20mA
Continuous Power Dissipation ($T_A = +70^\circ\text{C}$)	

10-pin μMAX (derate 8.8mW/ $^\circ\text{C}$ above $+70^\circ\text{C}$).....	707.3mW
Temperature Ratings	
Operating Temperature Range.....	-40°C to $+125^\circ\text{C}$
Maximum Junction Temperature	$+150^\circ\text{C}$
Storage Temperature Range	-65°C to $+150^\circ\text{C}$
Lead Temperature (soldering, 1s).....	$+300^\circ\text{C}$
Soldering Temperature (reflow).....	$+260^\circ\text{C}$

Stresses beyond those listed under "Absolute Maximum Ratings" may cause permanent damage to the device. These are stress ratings only, and functional operation of the device at these or any other conditions beyond those indicated in the operational sections of the specifications is not implied. Exposure to absolute maximum rating conditions for extended periods may affect device reliability.

Package Information

10- μMAX

Package Code	U10+6C
Outline Number	21-0061
Land Pattern Number	90-0330
Thermal Resistance, Single Layer Board:	
Junction-to-Ambient (θ_{JA})	180
Junction-to-Case Thermal Resistance (θ_{JC})	42
Thermal Resistance, Four Layer Board:	
Junction-to-Ambient (θ_{JA})	113.1
Junction-to-Case Thermal Resistance (θ_{JC})	42

Electrical Characteristics

($V_{CC} - V_{GND} = 3.0\text{V}$ to 5.5V , $T_A = -40^\circ\text{C}$ to $+125^\circ\text{C}$, Typical values are at $V_{CC} = 5.0\text{V}$ and $T_A = +25^\circ\text{C}$, unless otherwise noted. ([Note 1](#)))

PARAMETER	SYMBOL	CONDITIONS	MIN	TYP	MAX	UNITS
POWER (V_{CC}, GND)						
Positive Supply Voltage	V_{CC}		3.0	5.0	5.5	V
Positive Supply Current	I_{CC}	EN = V_{CC}		0.7	1.0	mA
		EN = GND			2.0	μA
Undervoltage-Lockout Threshold	V_{UVLO}	V_{CC} rising	1.7	2.2	2.6	V
Undervoltage-Lockout Threshold Hysteresis	V_{UVHYST}			50		mV
DIGITAL LOGIC INTERFACE (MC, FS, RS, EN, ZCO)						
Input Voltage High	V_{IH}		$0.7 \times V_{CC}$			V
Input Voltage Low	V_{IL}		$0.3 \times V_{CC}$			V
Input Hysteresis	V_{HYS}	$V_{CC} = 3\text{V}$	300			mV
		$V_{CC} = 5.5\text{V}$	550			
Input leakage Current	I_{LK}		-1		+1	μA

($V_{CC} - V_{GND} = 3.0V$ to $5.5V$, $T_A = -40^{\circ}C$ to $+125^{\circ}C$, Typical values are at $V_{CC} = 5.0V$ and $T_A = +25^{\circ}C$, unless otherwise noted. ([Note 1](#)))

PARAMETER	SYMBOL	CONDITIONS		MIN	TYP	MAX	UNITS
Input Capacitance	C_{IN}				2		pF
Output Logic High Leakage Current	I_{OH_LK}	ZCO, $V_{ZCO} = 5.5V$				+1	μA
Output Voltage Low	V_{OL}	ZCO, $I_{OUT} = 4mA$				0.4	V
ANALOG SIGNAL INTERFACE (INP, INM)							
Peak to peak Differential Voltage $ V_{INP}-V_{INM} $ (Note 2 , Note 3)	V_{DF_PK}	All input configurations. See the Input Types: Bipolar and Unipolar .		0.8		2.5	V
Differential Input common-mode voltage	V_{DF_CM}	SE or DF Input	Type 1		0		V
		DF Input	Type 2		0.625		
		SE Input	Type 2		1.25		
INM Voltage	V_{INM}	SE Input	Type 3, 4		0		V
FILTER CHARACTERISTICS, FS = 0 (LOW PASS FILTER)							
Upper Passband Frequency	$f_{C_LPF_PASS_60}$	MC = '0', -3dB			56		Hz
	$f_{C_LPF_STOP_60}$	MC = '0', -25dB			168		
	$f_{C_LPF_PASS_120}$	MC = '1', -3dB			112		
	$f_{C_LPF_STOP_120}$	MC = '1', -25dB			336		
Slope in Transition		Between passband edge and stopband edge			-80		dB/dec
FILTER CHARACTERISTICS, FS = 1 (BAND PASS FILTER)							
Upper Passband Frequency	$f_{C_BPF_PASS_UP_50}$	Mode = '0', -3dB			86		Hz
Lower Passband Frequency	$f_{C_BPF_PASS_LO_50}$	Mode = '0', -3dB			27		Hz
Upper Passband Frequency	$f_{C_BPF_PASS_UP_60}$	Mode = '1', -3dB			96		Hz
Lower Passband Frequency	$f_{C_BPF_PASS_LO_60}$	Mode = '1', -3dB			37		Hz
Slope in Transition		Between passband edge and stopband edge			-40		dB/dec
ZERO CROSSING DETECTION, FS=0 (LOW PASS FILTER)							
Zero Crossing Time Delay (Note 4)	$t_{D_LPF_ZCR_60}$	FS = MC = RS = '0', Total Time Delay with 60Hz input, DCAP = 220nF; $T_A = 0^{\circ}C$ to $+85^{\circ}C$. See the Input Types: Bipolar and Unipolar .		6.6	7.7	9.2	msec
Zero Crossing Time Delay (Note 4)	$t_{D_FW_ZCR_120}$	FS = '0', MC = RS = '1', Total Time Delay with 120Hz input, DCAP = 220nF; $T_A = 0^{\circ}C$ to $+85^{\circ}C$. See the Input Types: Bipolar and Unipolar .		-4.5	-3.7	-2.8	msec
Zero Crossing Time Delay (Note 4)	$t_{D_HW_ZCR_60}$	FS = MC = '0', RS = '1', Total Time Delay with 60Hz input, DCAP = 220nF; $T_A = 0^{\circ}C$ to $+85^{\circ}C$. See the Input Types: Bipolar and Unipolar .		5.3	6.2	7.5	msec

($V_{CC} - V_{GND} = 3.0V$ to $5.5V$, $T_A = -40^{\circ}C$ to $+125^{\circ}C$, Typical values are at $V_{CC} = 5.0V$ and $T_A = +25^{\circ}C$, unless otherwise noted. ([Note 1](#)))

PARAMETER	SYMBOL	CONDITIONS	MIN	TYP	MAX	UNITS
Zero Crossing Time Delay Repeatability (Note 4), (Note 5)	$\Delta t_{D_LPF_ZCR_60}$	FS = MC = RS = '0', Total Time Delay Variation with 60Hz input, DCAP = 220nF; $T_A = 0^{\circ}C$ to $+85^{\circ}C$	-16		+16	μsec
Zero Crossing Time Delay Repeatability (Note 5)	$\Delta t_{D_FW_ZCR_120}$	FS = '0', MC = RS = '1', Total Time Delay Variation with 120Hz input, DCAP = 220nF; $T_A = 0^{\circ}C$ to $+85^{\circ}C$	-20		+20	μsec
Zero Crossing Time Delay Repeatability (Note 4), (Note 5)	$\Delta t_{D_HW_ZCR_60}$	FS = MC = '0', RS = '1' Total Time Delay Variation with 60Hz input, DCAP = 220nF; $T_A = 0^{\circ}C$ to $+85^{\circ}C$	-16		+16	μsec
Zero Crossing Comparator Reference		FS = '0'		V_{DCAP}		V
ZERO CROSSING DETECTION, FS=1 (BAND PASS FILTER)						
Zero Crossing Time Delay (Note 4)	$t_{D_BPF_ZCR_50}$	FS = '1', MC = '0', Total Time Delay with 50Hz input; $T_A = 0^{\circ}C$ to $+85^{\circ}C$. See the Input Types: Bipolar and Unipolar .	-200	0	200	μsec
	$t_{D_BPF_ZCR_60}$	FS = '1', MC = '1', Total Time Delay with 60Hz input; $T_A = 0^{\circ}C$ to $+85^{\circ}C$. See the Input Types: Bipolar and Unipolar .	-200	0	200	
Zero Crossing Time Delay Repeatability (Note 4), (Note 5)	$\Delta t_{D_BPF_ZCR}$	FS = '1', Total Time Delay Variation with 50Hz or 60Hz input	-21		+21	μsec
ZC Comparator Reference		FS = '1'		INM		
PROTECTION						
ESD Protection (All Pins to GND)		Human Body Model		± 2		kV

Note 1: All units are production tested at $T_A = +25^{\circ}C$. Specifications over temperature are guaranteed by design.

Note 2: Differential input is between INP and INM.

Note 3: Input voltage is signal without noise.

Note 4: Measurement performed with noise ($V_{NOISE} = V_{IN_RMS}/17$ and $f_{NOISE} = 4 \times f_{SIG}$) added to input signal. V_{IN_RMS} is the RMS voltage of the input signal and f_{IN} is the input frequency (e.g. 50Hz, 60Hz). For Type 1, 2, and 4 inputs, $f_{SIG} = f_{IN}$ while for Type 3 inputs, $f_{SIG} = 2 \times f_{IN}$. Input frequency must vary less than 1% of nominal.

Note 5: Repeatability refers to cycle-to-cycle variation of the delay for a single part and applies for a single set of conditions (i.e., fixed input frequency and fixed input amplitude).

Typical Operating Characteristics

(V_{CC} , V_{GND} = 3.0V to 5.5V, T_A = 25°C, unless otherwise noted.)

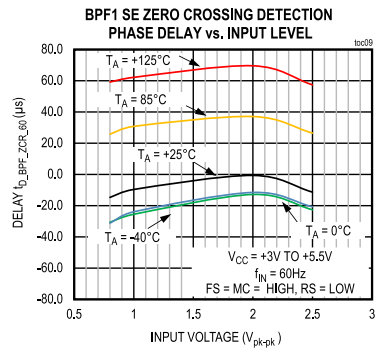
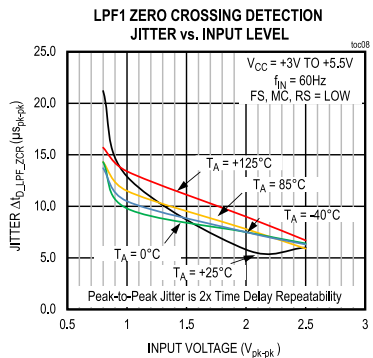
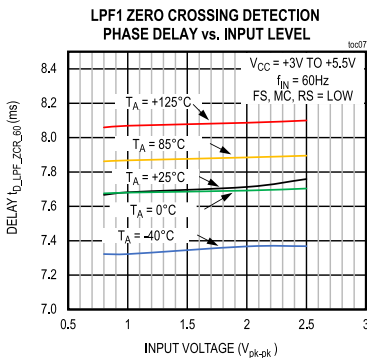
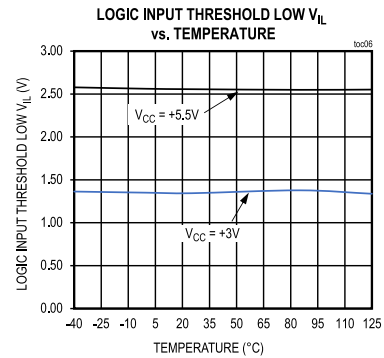
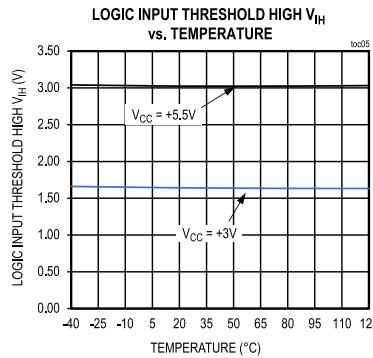
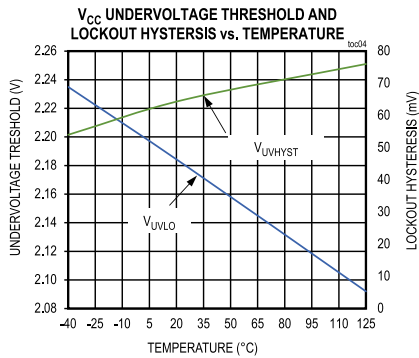
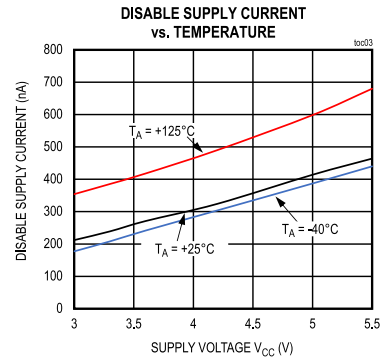
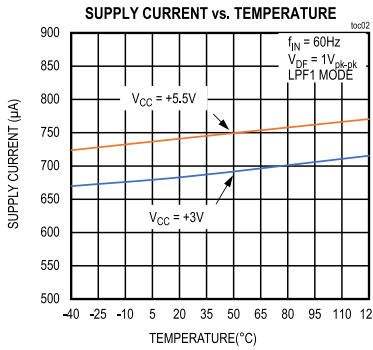
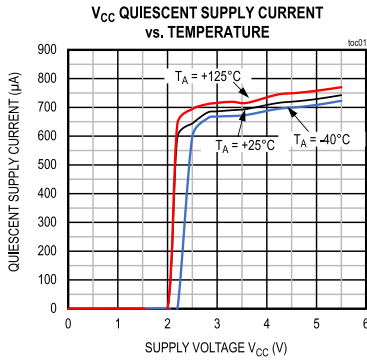

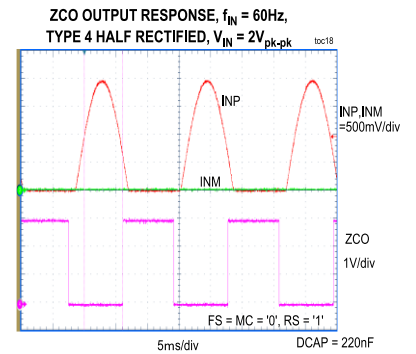
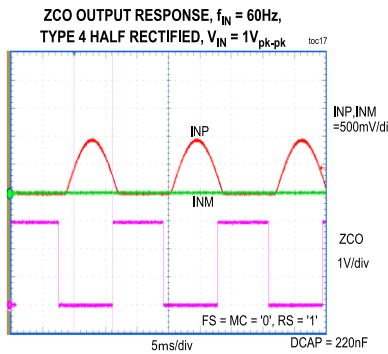
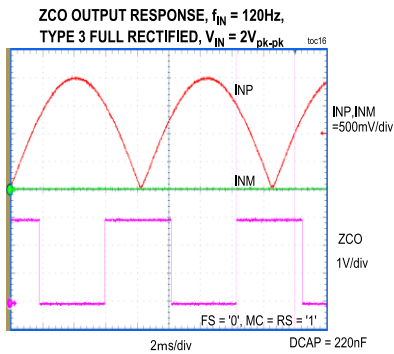
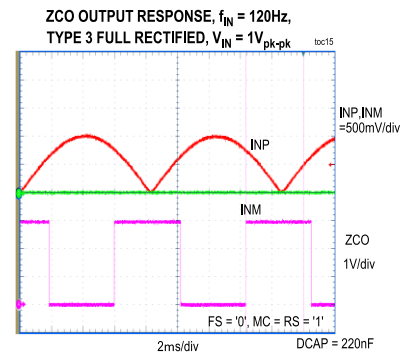
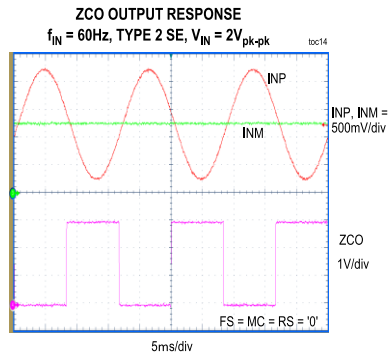
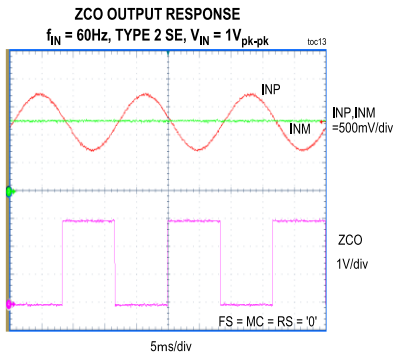
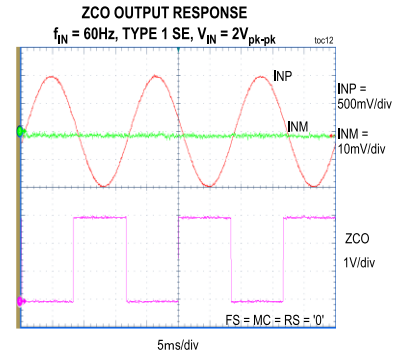
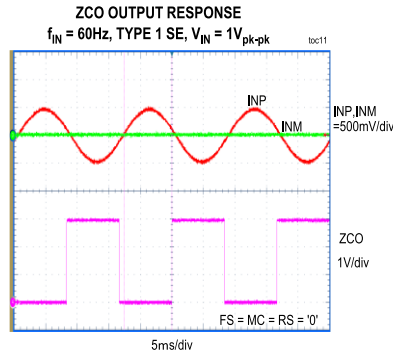
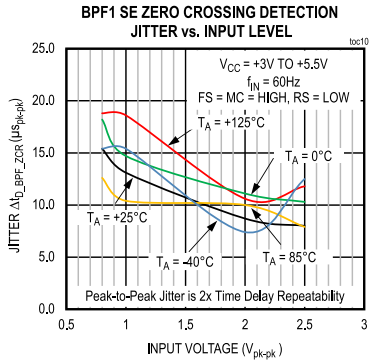

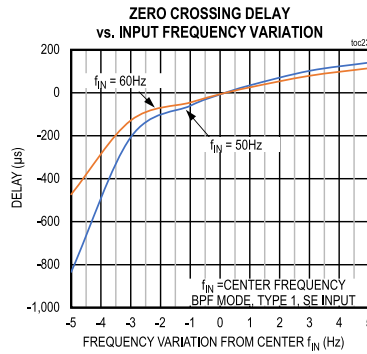
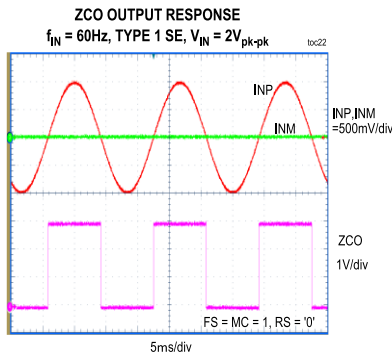
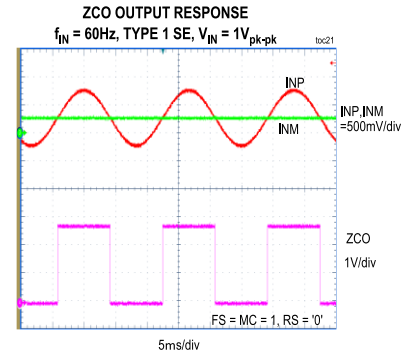
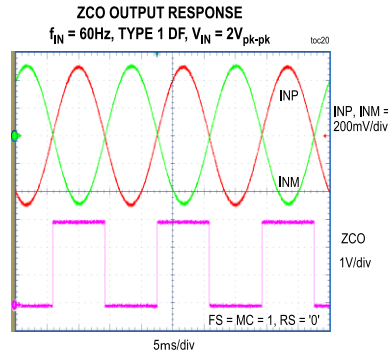
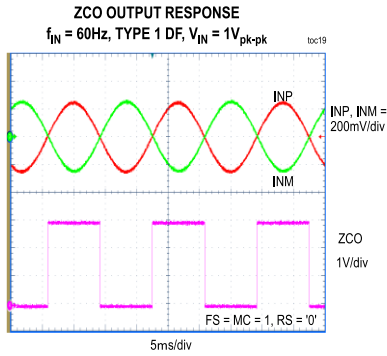

Pin Configurations

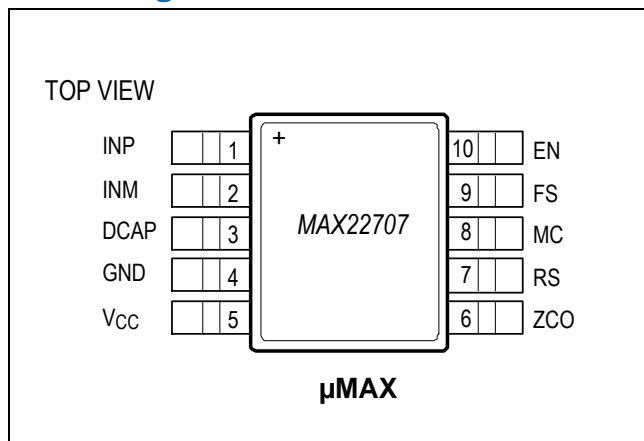

Pin Descriptions

PIN	NAME	FUNCTION	Type
1	INP	Input Positive AC Voltage (Line)	Analog Input
2	INM	Input Negative AC Voltage (Neutral). Connect based on input configuration.	Analog Input
3	DCAP	DC averaging capacitor for LPF mode. Connect a 220nF capacitor to ground. When using BPF mode connect DCAP to ground.	Analog Output
4	GND	Ground return.	Supply

5	VCC	Positive Supply, $V_{CC} = 3.0V$ to $5.5V$. Bypass V_{CC} to GND with a $0.1\mu F$ capacitor	Supply
6	ZCO	Zero Crossing Open-Drain Output	Digital Output
7	RS	Rectified Input Selection. Set to 0 for sine wave input or set to 1 for rectified input.	Digital Input
8	MC	Mode Control. When $FS = 0$ (LPF): Set to 0 for 50/60Hz or Set to 1 for 100/120Hz. When $FS = 1$ (BPF): Set to 0 for 50Hz or set to 1 for 60Hz.	Digital Input
9	FS	Filter Selection. Set to 0 for Low Pass Filter (LPF) or Set to 1 for Band Pass Filter (BPF).	Digital Input
10	EN	Set to 1 to Enable. Set to 0 to power down.	Digital Input

Functional Block Diagram

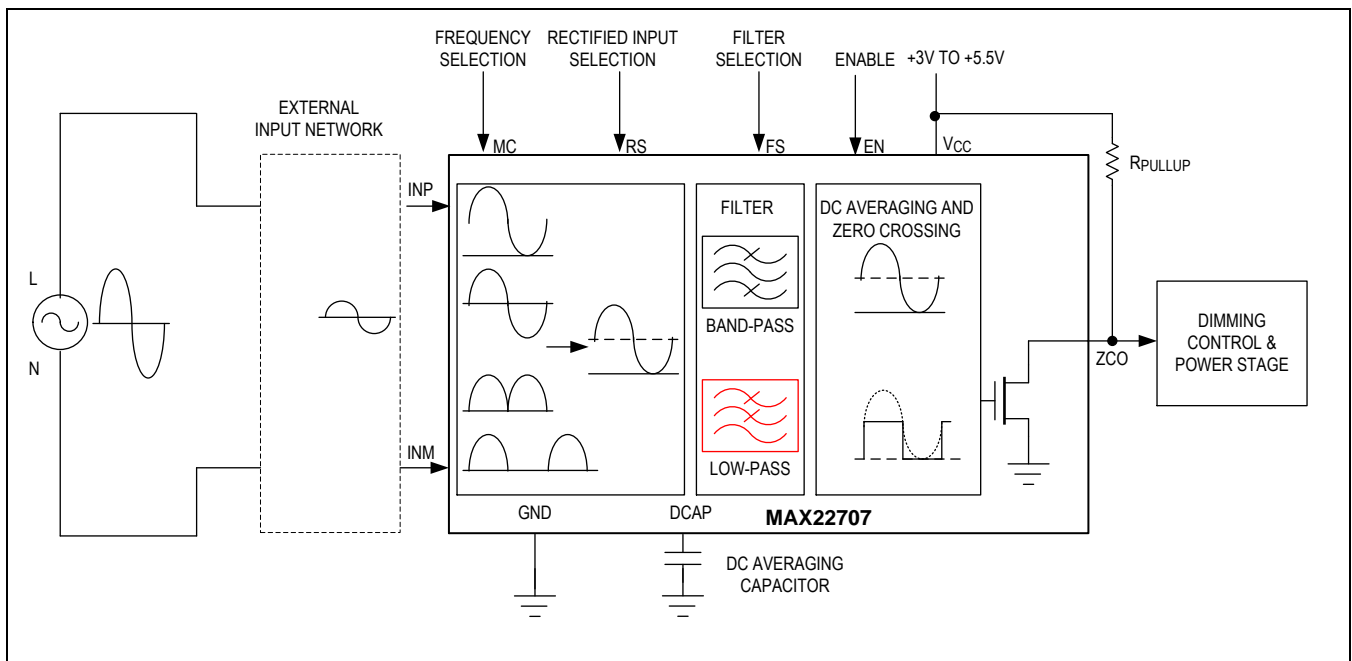

Detailed Description

The MAX22707 precision zero crossing detector provides a reliable and repeatable zero crossing detection signal based on an AC line input. The use of switched-capacitor filters helps to ensure minimal zero-crossing delay while tracking change in the input frequency and provides higher precision and a more inherently stable output than discrete solutions.

The MAX22707 features a low-power, precision analog filter based on the switched-capacitor technology designed for precision filtering of AC input noise. The device requires only a simple external input network preceding the AC inputs and no additional external components for the filters. The two different filter types can be selected by the Filter Selection pin (FS). The available filter types are the fourth order BPF and LPF. The DC averaging filter capacitor function is used for the latter.

The MAX22707 supports two standard line frequencies (50Hz and 60Hz) for both the filter types as well as rectified inputs in the case of LPF. If the BPF is selected, then the frequency selection Mode Control pin (MC) is used to select between 50Hz and 60Hz. If the LPF is selected, then the same pin is used to choose between 50/60Hz or 100/120Hz signal band (see [Table 1](#)). The Rectified Select pin (RS) is used to select between sine and rectified units (see [Table 2](#)). The MAX22707 is available in a compact 10-pin μ MAX package and operates over the -40°C to $+125^{\circ}\text{C}$ temperature range.

Mode Control

The combination of Mode Control (MC) and Filter Select (FS) inputs determine the application mode from Type 1 to 4 as described in the section [Input Types: Bipolar and Unipolar](#).

Table 1. Mode Control – Selecting the Input Frequency

Mode Control (MC)	Filter Select (FS) = 0, LPF	Filter Select (FS) = 1, BPF
0	50 / 60Hz	50Hz
1	100 / 120Hz	60Hz

Input Stage Requirements

The input stage connected to the MAX22707 is comprised of a voltage divider that attenuates the high voltage AC line to the device input level and an anti-aliasing filter for the internal switched capacitor circuits. The MAX22707 handles both asymmetrical (SE) and symmetrical (DF) and bipolar and unipolar signals with the appropriate device configuration (FS, MC and RS) and the input network components.

When the LPF is selected (FS = 0), then the input stage has high voltage input with high ohmic series resistors ($>100\text{k}\Omega$) in series and voltage divider to generate properly scaled single ended input signal to MAX22707 inputs (INP, INM). When the BPF is selected (FS = 1), then the input stage has the differential high voltage input with high ohmic series resistors ($>100\text{k}\Omega$) in series and properly matched resistor divider feeding to the MAX22707 inputs (INP, INM). For the input types, see [Input Types: Bipolar and Unipolar](#). For the input network configurations, see [Input Network](#).

Negative Input

When bipolar input mode is selected, the inputs INP and INM must stay between $+V_{\text{CC}}$ and $-V_{\text{CC}}$. The input signal is filtered and compared with the ground reference to provide the zero-crossing signal.

Rectified Input Selection

The combination of Rectified Selection (RS) and Filter Select (FS) inputs determine the correct configuration for input Types 1 and 2 (Sinewave) or Type 3 (fully rectified) and Type 4 (half rectified).

Table 2. Rectified Selection

Rectified Selection (RS)	Filter Select (FS) = 0, LPF	Filter Select (FS) = 1, BPF
0	Sinewave	Not a Valid State
1	Rectified	Not a Valid State

Filters

The MAX22707 has two different types of filters, LPF and BPF, which are selected by the FS input pin (low for LPF or high for BPF). When the LPF is selected, an external capacitor must be included at the DCAP pin to provide DC averaged reference for the zero-crossing detection operation.

Input Types: Bipolar and Unipolar

The MAX22707 requires an external R-C input network to attenuate the AC line input to acceptable signal levels, while also providing the anti-aliasing filtering (as required with a sampled system using switched capacitors). The output of the input network is a differential signal that is applied to the INP and INM pins, after which it is converted to a single-ended signal and level shifted to maximize the filter input and output ranges. The MAX22707 has six different input configurations, two bipolar and four unipolar, defined as Type 1 to 4 and described in the following figures:

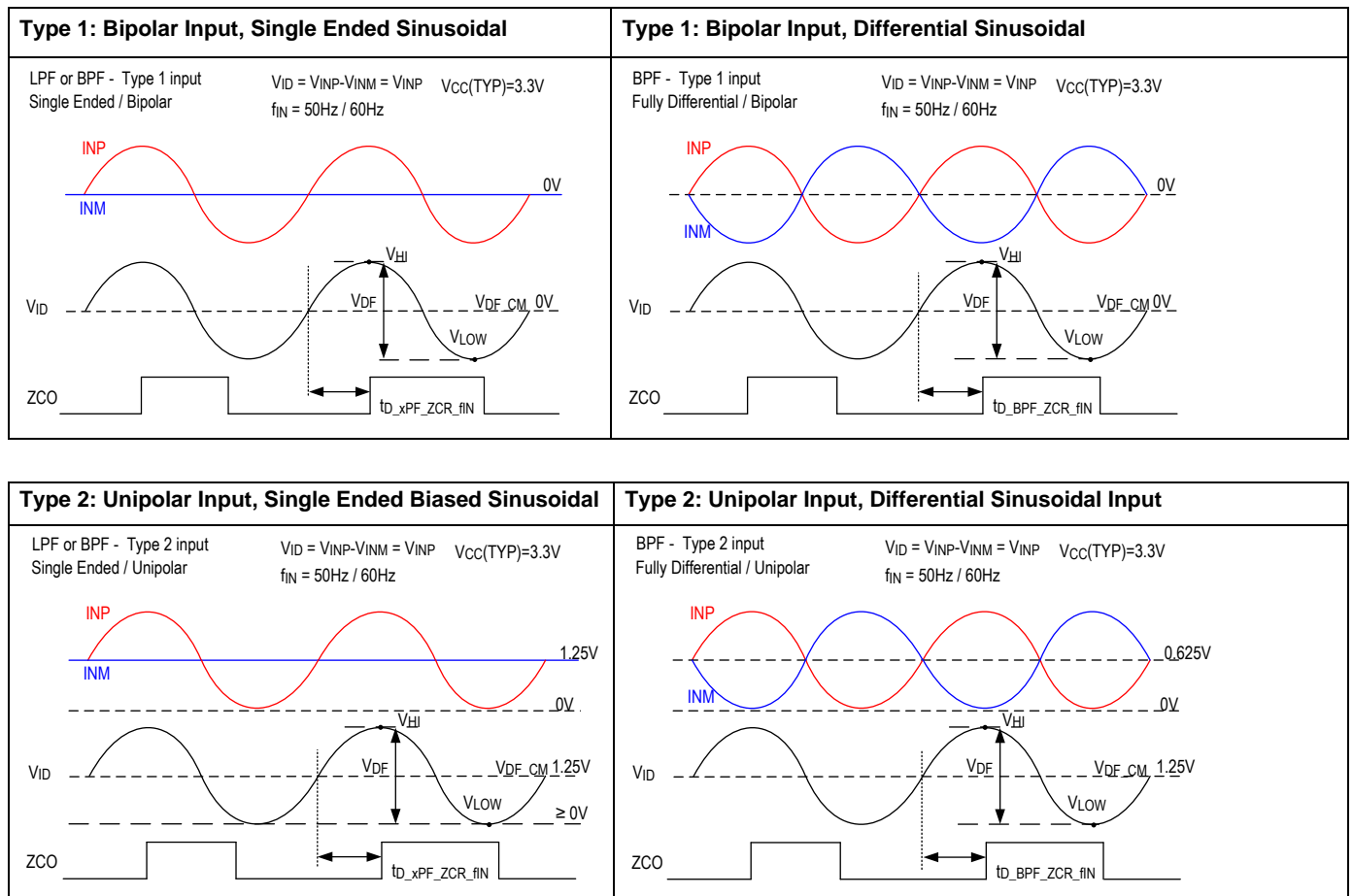

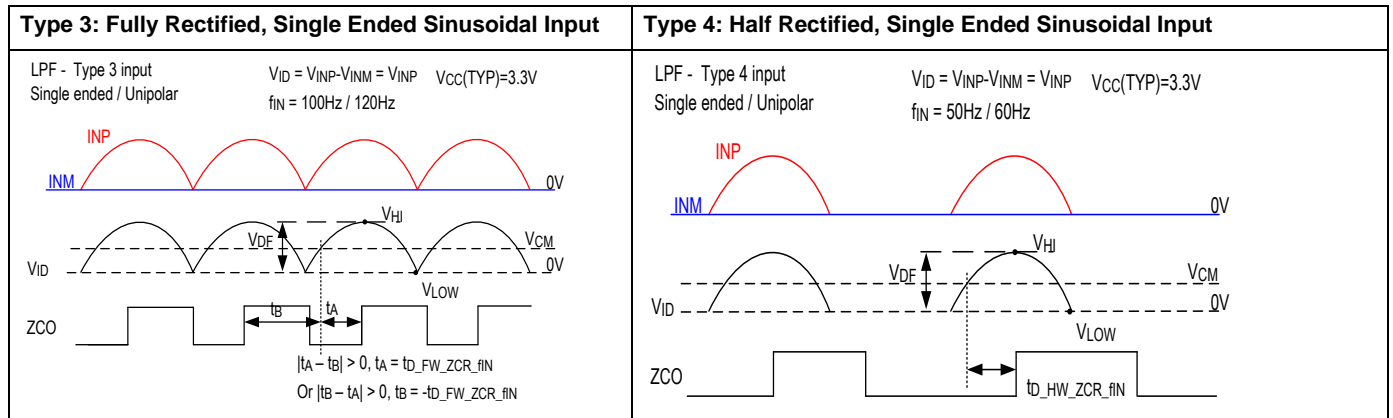

Applications Information

Input Network

The external input network attenuates the input from AC line to the MAX22707 acceptable input range and performs anti-aliasing for the switched capacitor filters. See the [Figure 1](#) for the Input network for low pass configuration (left) and the [Figure 2](#) for the input network for band pass configuration (right).

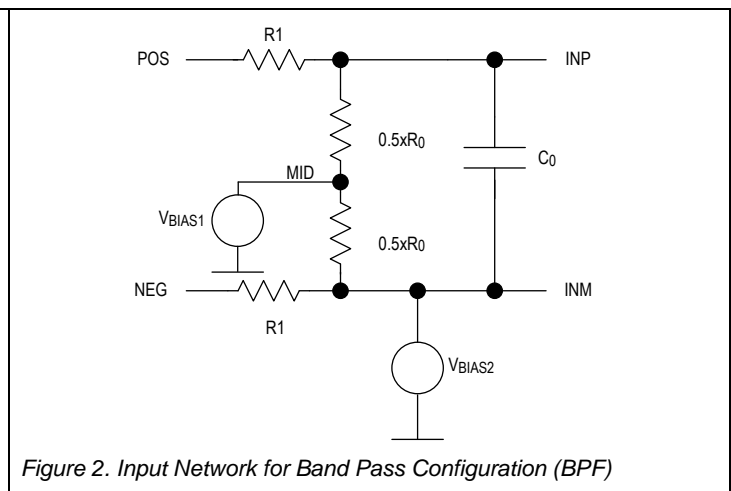
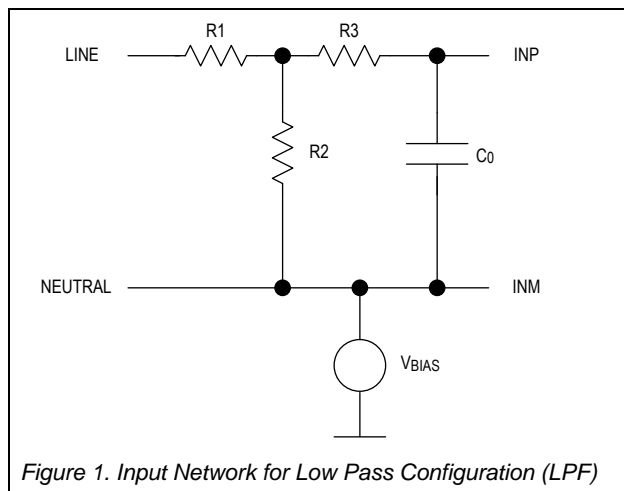

See below tables for input network values, [Table 3](#) for the LPF Configuration and [Table 4](#) for the BPF Configuration. The values shown for the input network for each input configuration attenuate 280V_{AC} to 2.5V_{pk-pk} and limit the bandwidth to 5kHz. The component values below may be modified for different AC standards while ensuring a 2.5V_{pk-pk} full-scale signal at MAX22707 inputs and maintaining a high input series resistance (>100kΩ). If the AC input has been attenuated, in the case of the LPF input configuration R1 and R2 may be omitted.

Table 3. Input Network Values for the LPF Configuration

Input network configuration	Type	Input	R1 (Ω)	R2 (Ω)	R3 (Ω)	C0 (nF)	VBIAS (V)
LPF	1	SE	200k	633	1447	22	0
	2	SE	200k	633	1447	22	1.25
	3,4	SE	200k	1271	1447	22	0

Table 4. Input Network Values for the BPF Configuration

Input network configuration	Type	Input	R1 (Ω)	R0 (Ω)	C ₀ (nF)	V _{BIAS1} (V)	V _{BIAS2} (V)
BPF	1	DF	229k	1452	22	0	n/a
	1	SE	229k	1452	22	n/a	0
	2	DF	229k	1452	22	0.625	n/a
	2	SE	229k	1452	22	n/a	1.25

Full Wave Rectified Inputs

As listed in the [Electrical Characteristics](#), the delay repeatability is performed without noise. This is vital in the full-wave rectified case since any imperfection of the rectified input signal results in worse zero-crossing time delay repeatability. The repeatability as specified in the Electrical Characteristics applies for an ideal full wave rectified signal.

The imperfection may result from the method of rectification or from the noise. In either case, the magnitude of the delay repeatability is larger than for an ideal signal since the input waveform is not periodic. As an example of the former case, a full wave rectified input is commonly generated as a composite signal. Given the tolerance of discrete components, some finite phase delay exists between the various paths of the constituent signals, resulting in phase delay between adjacent lobes of the rectified signal and worse zero-crossing delay repeatability.

Power Supply

The MAX22707 does not require special power supply sequencing. It is recommended to bypass V_{CC} supply with a 0.1 μ F low-ESR ceramic capacitor placed as close to the device V_{CC} pin as possible.

ESD and EMC Testing

The MAX22707 is required to operate reliably in harsh industrial environments. The device can meet the transient immunity requirements as specified in IEC 61000-4, including Electrostatic Discharge (ESD) per IEC 61000-4-2, Electrical Fast Transient/Burst (EFT) per IEC 61000-4-4, and Surge Immunity per IEC 61000-4-5. Maxim's proprietary process technology provides robust input channels and power supply with internal ESD structures and high Absolute Maximum Ratings, but external components are also required to absorb excessive energy from ESD and surge transients. For more information on the input circuit schematic and components, refer to the MAX22707 EV Kit data sheet that allows MAX22707 to meet transient levels as listed in [Table 5](#).

Table 5. ESD and Transient Immunity Characteristics

PARAMETER	SYMBOL	CONDITIONS	VALUE	UNITS
Surge	IN_ to Earth GND	$\geq 100k\Omega$ input resistor from Line to System / Earth Ground, IEC 61000-4-5 1.2 μ s/50 μ s pulse	± 6	kV
	IN_ to IN_	$\geq 100k\Omega$ input resistor from Line (Live) to Line (Neutral), IEC 61000-4-5 1.2 μ s/50 μ s pulse	± 6	
EFT	IN_ to Earth GND	Power line cable in capacitive clamp to input cable pair (IN_ to GND) with $\geq 100k\Omega$ input resistor from Line to GND, IEC61000-4-4	± 3	
ESD	IN_ Contact	$\geq 100k\Omega$ input resistor in series with IN_ with respect to GND, IEC61000-4-2. LPF Mode: External TVS diode at INM to GND, optional external TVS diode at INP to GND, BPF Mode: Optional external TVS diode at INP to GND and INM to GND.	± 8	
	IN_ Air Gap	$\geq 100k\Omega$ input resistor in series with IN_ with respect to GND, IEC61000-4-2. LPF Mode: External TVS diode at INM to GND, optional external TVS diode at INP to GND, BPF Mode: Optional external TVS diode at INP to GND and INM to GND.	± 15	

Layout Considerations

The PCB designer should follow some critical recommendations to get the best performance from the design:

- Keep the input/output traces as short as possible. To keep signal path low inductance, avoid using vias.
- Have a solid ground plane underneath the input-output signal layer.
- Ensure to have ground keep-out from high voltage input interface.
- Ensure to maintain right creepage and clearance between components and traces at the input network until the signal is low voltage.

Typical Application Circuits

The MAX22707 can be used with any combination of input types (single ended/differential inputs) and polarity (unipolar/bipolar). Different R-C attenuation networks are recommended for the different input configurations the MAX22707 can be used in. See the [Input Network](#) section to calculate the input network components for the specific input level and type. [Table 6](#) shows the applications modes.

Table 6. Application Modes

FS	MC	RS	Mode	Refer to Figure
0	0	0	Sinewave input, 50/60Hz, LPF	Figure 3, Figure 4
0	1	0	Not a Valid State	N/A
0	1	1	Full Wave Rectified Input, 50/60Hz, LPF	Figure 5
0	0	1	Half Wave Rectified Input, 100/120Hz, LPF	Figure 6
1	0	0	Sinewave input, 50Hz, BPF	Figure 8, Figure 9
1	1	0	Sinewave input, 60Hz, BPF	Figure 7, Figure 10
1	0	1	Not a Valid State	N/A
1	1	1	Not a Valid State	N/A

LPF for the Bipolar Sinewave Single Ended 50/60Hz Input

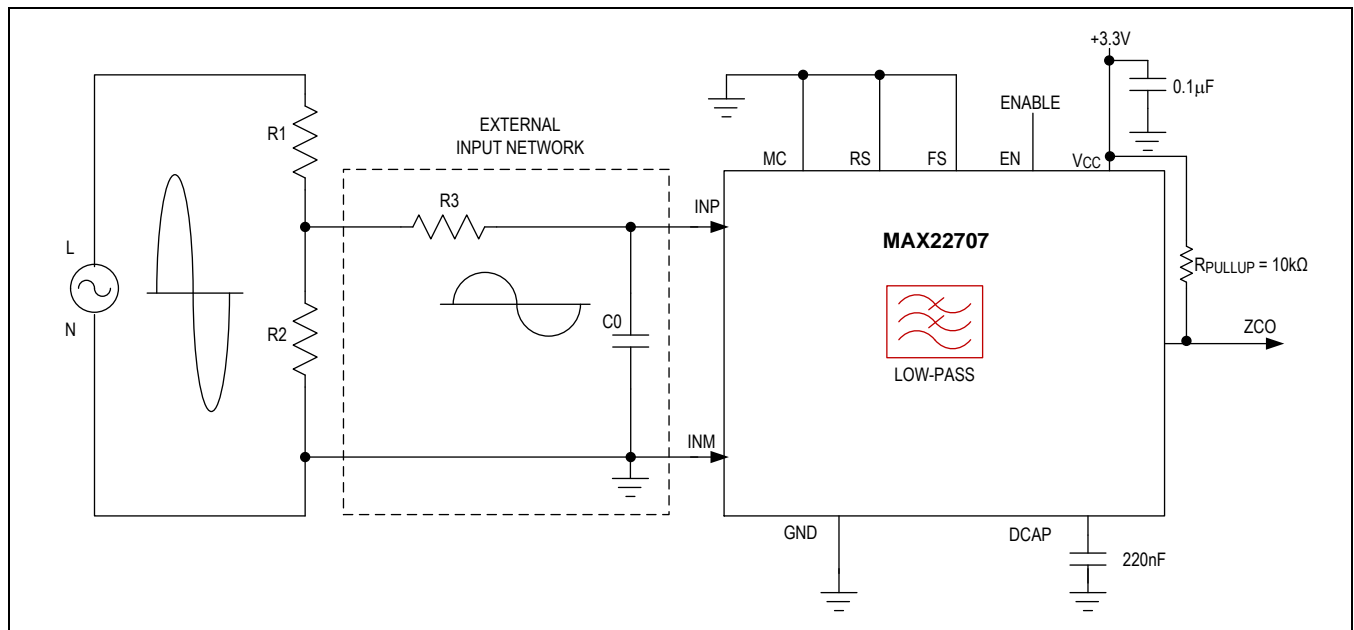

Figure 3. LPF for the Bipolar Sinewave Single Ended 50/60Hz Input

LPF for the Unipolar Biased Single Ended 50/60Hz Input

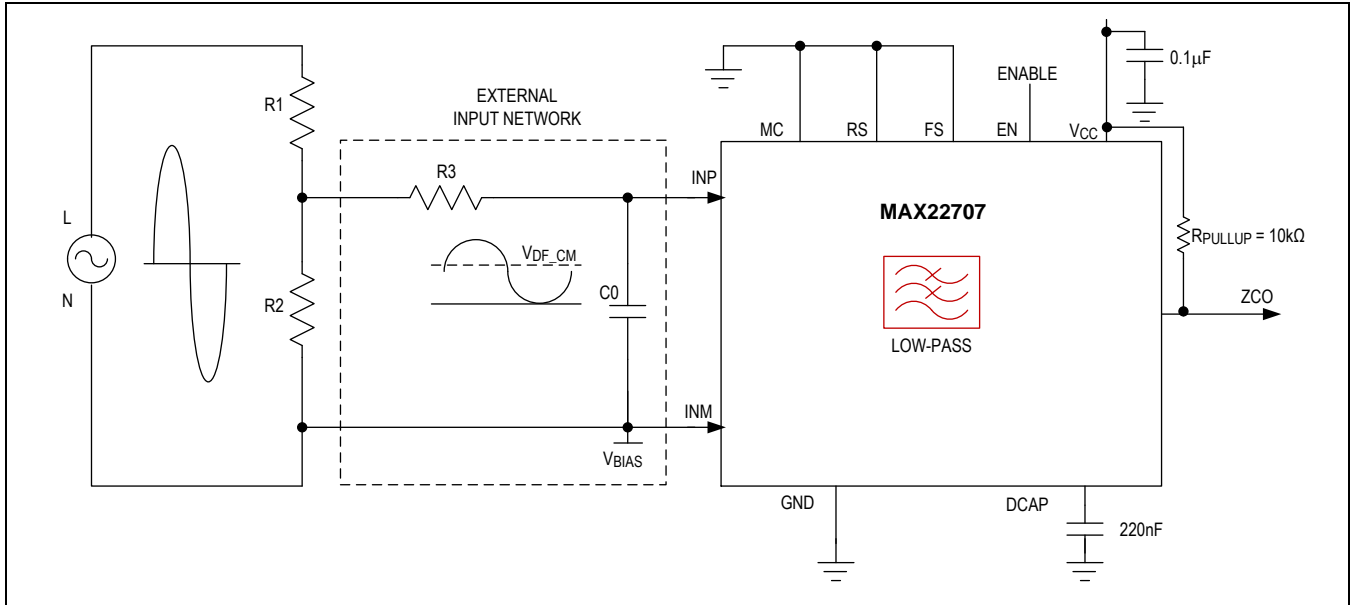

Figure 4. LPF for the Unipolar Biased Single Ended 50/60Hz Input

LPF for the Full-Rectified 100/120Hz Input

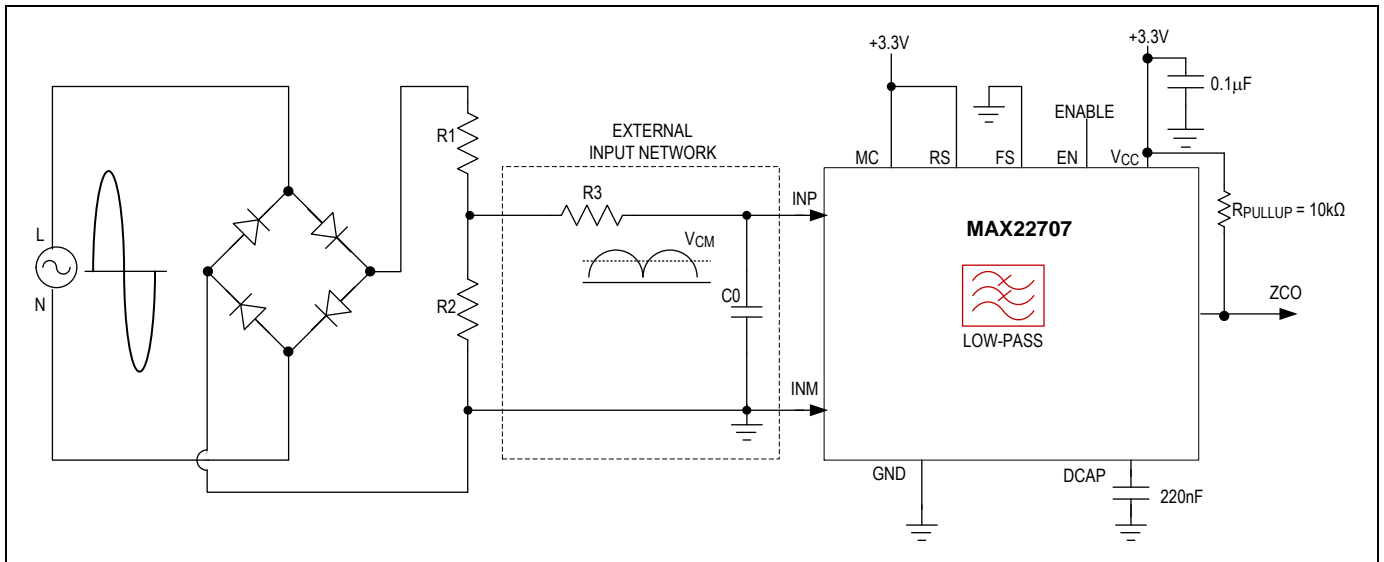

Figure 5. LPF for the Full-Rectified 100/120Hz Input

LPF for the Half-Rectified 50/60Hz Input

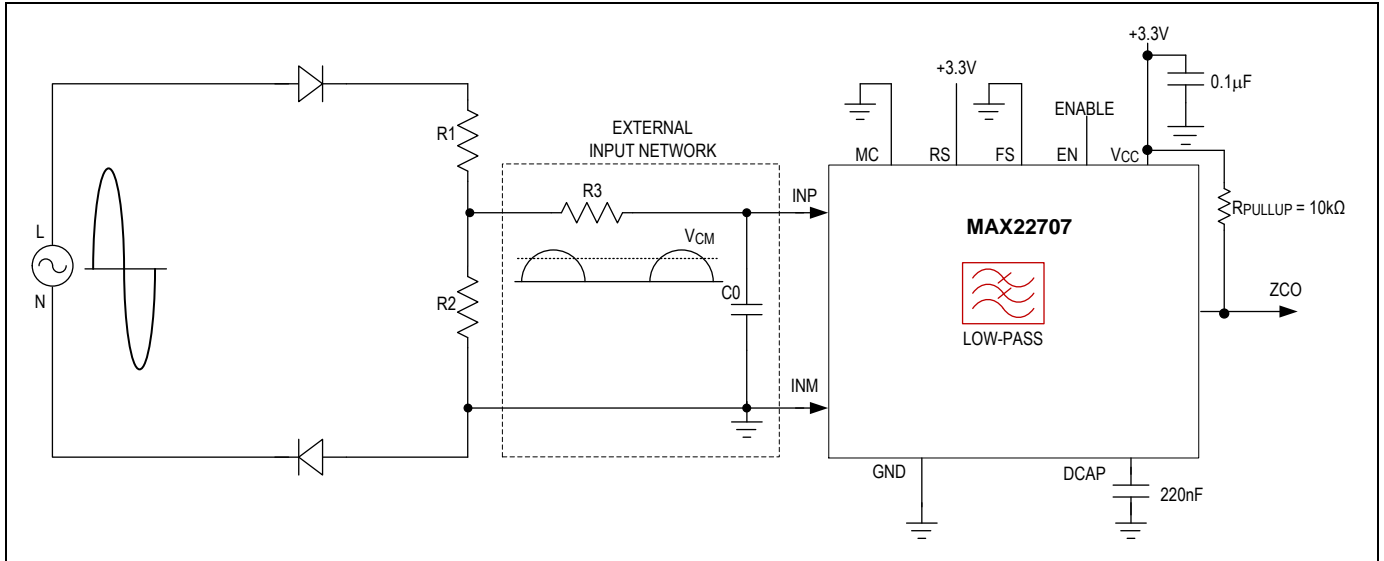

Figure 6. LPF for the Half-Rectified 50/60Hz Input

BPF for the Bipolar Differential 60Hz Input

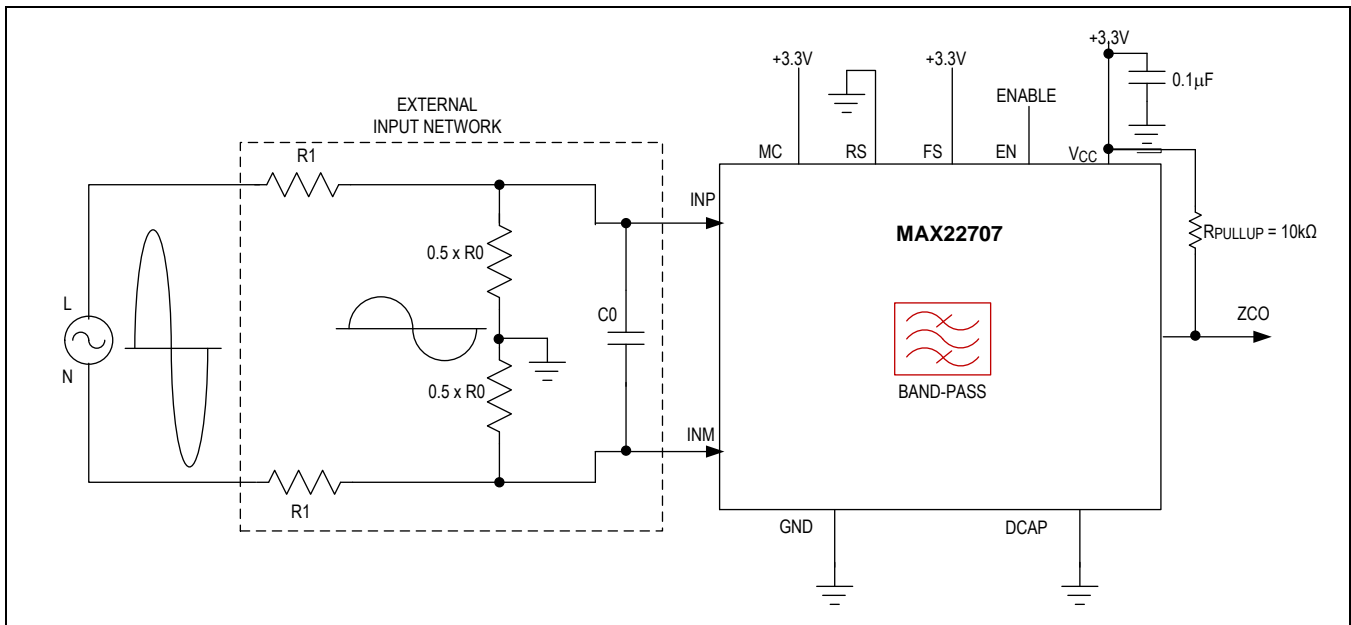

Figure 7. BPF for the Bipolar Differential 60Hz Input

BPF for the Bipolar Single Ended 50Hz Input

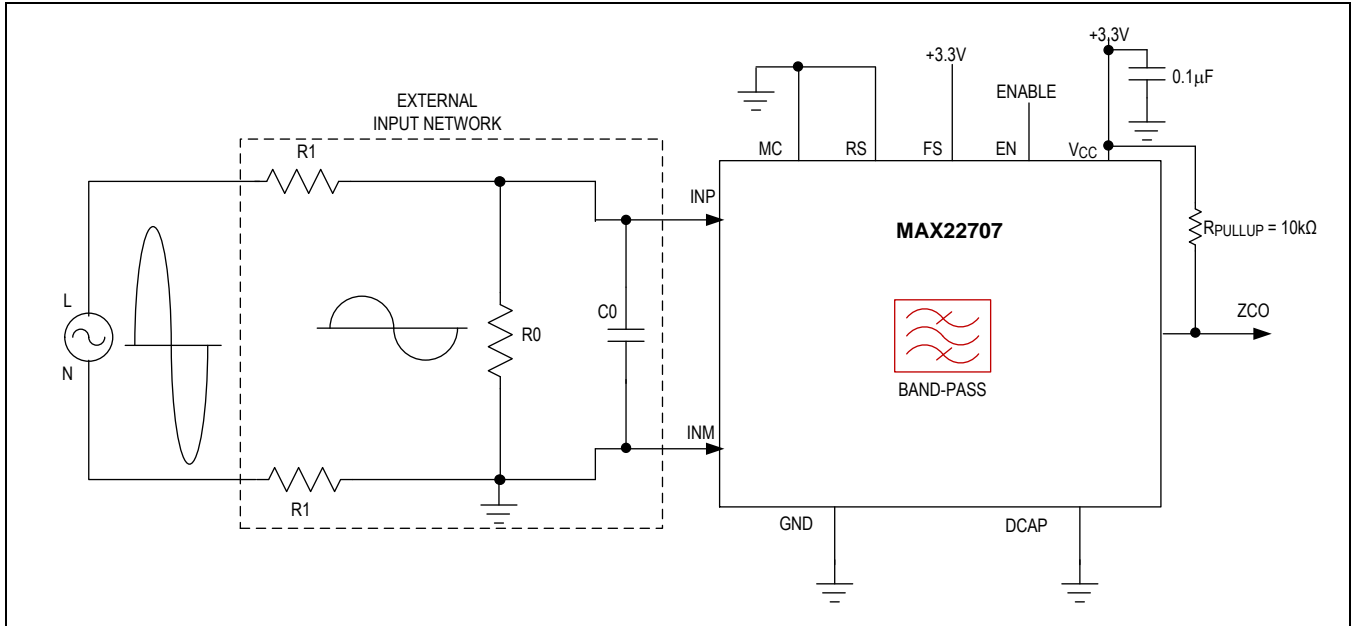

Figure 8. BPF for the Bipolar Single Ended 50Hz Input

BPF for the Unipolar Biased Differential 50Hz Input

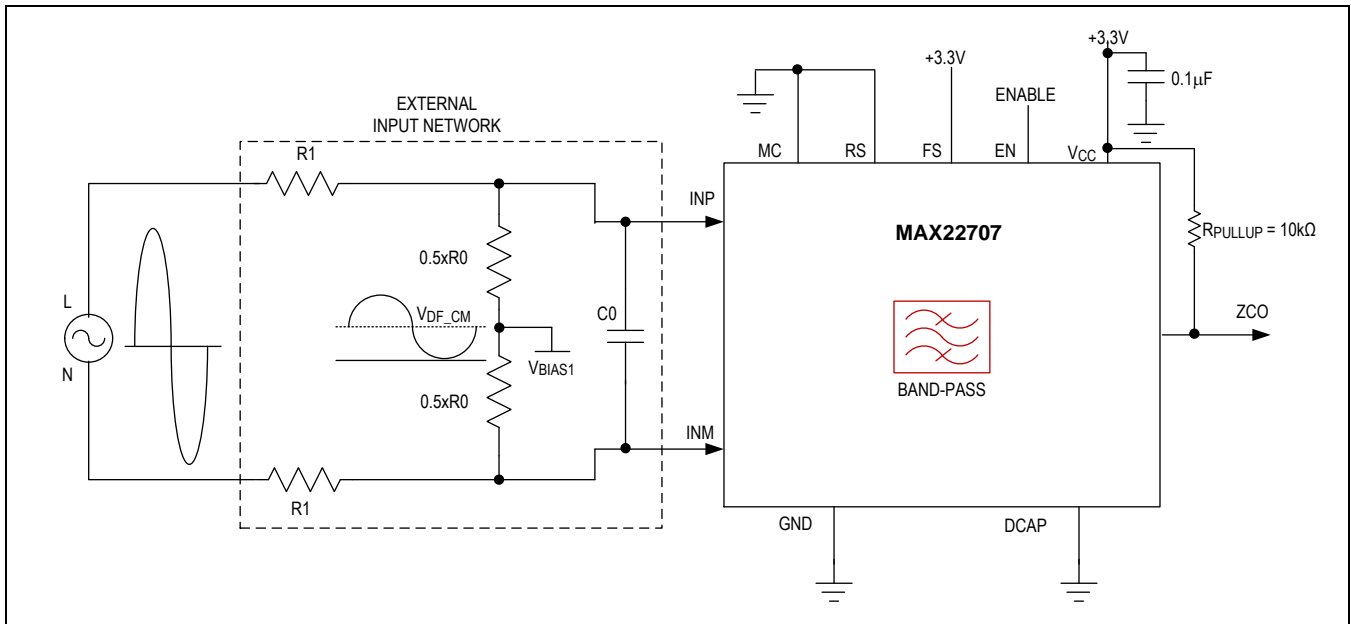

Figure 9. BPF for the Unipolar Biased Differential 50Hz Input

BPF for the Unipolar Biased Single Ended 60Hz Input

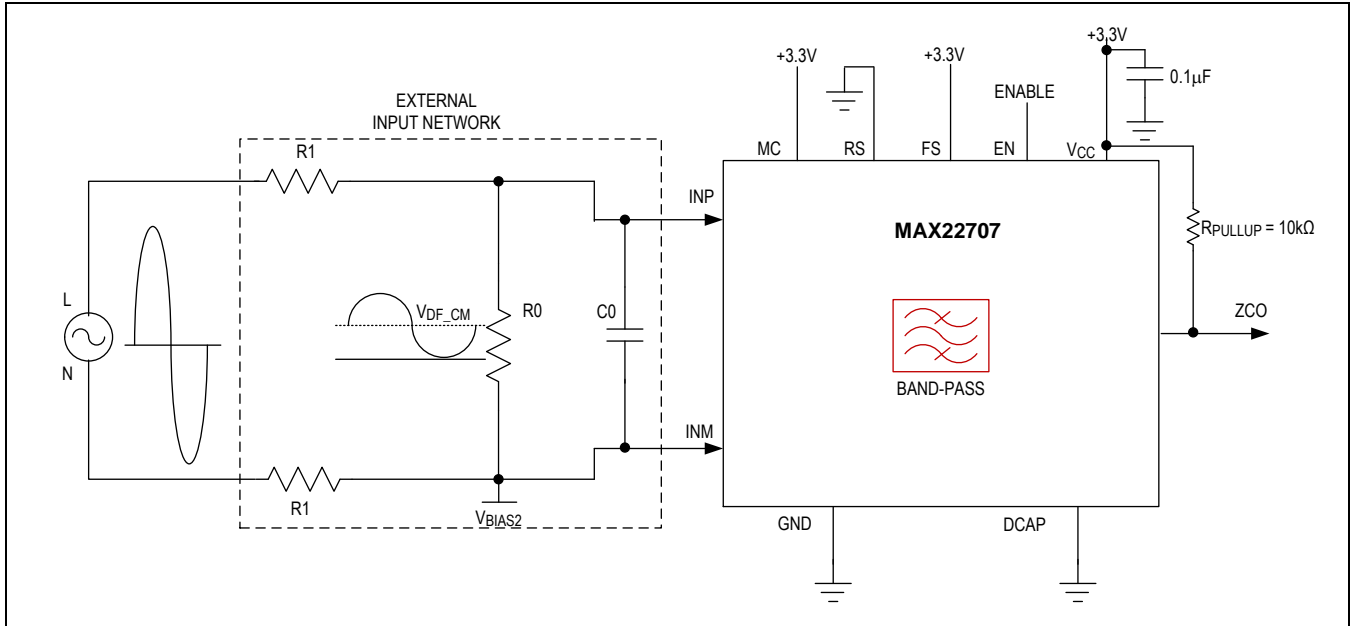

Figure 10. BPF for the Unipolar Biased Single Ended 60Hz Input

Ordering Information

PART NUMBER	TEMP RANGE	PIN-PACKAGE
MAX22707AUB+	-40°C to +125°C	10-pin µMAX
MAX22707AUB+T	-40°C to +125°C	10-pin µMAX

+Denotes a lead(Pb)-free/RoHS-compliant package.

T = Tape-and reel.

Chip Information

PROCESS: BiCMOS

Revision History

REVISION NUMBER	REVISION DATE	DESCRIPTION	PAGES CHANGED
0	12/21	Release for Market Intro	—



Looking for pricing, stock, or lifecycle information?

Click below to explore more details on WIN SOURCE:

 [View MAX22707AUB+](#) on WIN SOURCE

 [Maxim Integrated](#) Information

Optimize Your Supply Chain with WIN SOURCE Solutions

-  Global Sourcing Solution
-  Obsolete Management
-  Cost Control Management
-  Shortage Management
-  Alternative Solution
-  Excess Inventory Management