



**THE DATASHEET OF
LMR934FVJ-E2**



Operational Amplifiers

Input/Output Full Swing Low Power Operational Amplifiers

LMR981G LMR982FVM LMR931G LMR932xxx LMR934xxx

General Description

LMR981G/LMR982FVM/LMR931G/LMR932xxx/LMR934xxx are input/output full swing operational amplifiers. LMR981G/LMR982FVM have the shutdown function. They have the features of low operating supply voltage, low supply current and low input bias current. These are suitable for portable equipment and battery monitoring.

Features

- Low Operating Supply Voltage
- Input/Output Full Swing
- High Large Signal Voltage Gain
- Low Input Bias Current
- Low Supply Current
- Low Input Offset Voltage

Applications

- Portable Equipment
- Low Voltage Application
- Active Filter
- Supply-Current Monitoring
- Battery Monitoring

Key Specifications

- Operating Supply Voltage (Single Supply): +1.8V to +5.0V
- Voltage Gain (VDD=5V, R_L=600Ω): 101dB(Typ)
- Operating Temperature Range: -40°C to +85°C
- Turn on Time from Shutdown(VDD=1.8V): 19μs (Typ)
- Input Offset Voltage(T_A=25°C):
 - LMR981G(Single) 4mV(Max)
 - LMR931G(Single) 4mV(Max)
 - LMR982FVM(Dual) 5.5mV(Max)
 - LMR932xxx(Dual) 5.5mV(Max)
 - LMR934xxx(Quad) 5.5mV(Max)
- Input Bias Current: 5nA (Typ)

Package

Package	W(Typ) xD(Typ) xH(Max)
SSOP5	2.90mm x 2.80mm x 1.25mm
SSOP6	2.90mm x 2.80mm x 1.25mm
MSOP8	2.90mm x 4.00mm x 0.90mm
MSOP10	2.90mm x 4.00mm x 0.90mm
TSSOP-B8J	3.00mm x 4.90mm x 1.10mm
TSSOP-B8	3.00mm x 6.40mm x 1.20mm
SSOP-B8	3.00mm x 6.40mm x 1.35mm
SOP-J8	4.90mm x 6.00mm x 1.65mm
SOP8	5.00mm x 6.20mm x 1.71mm
TSSOP-B14J	5.00mm x 6.40mm x 1.20mm
SSOP-B14	5.00mm x 6.40mm x 1.35mm
SOP-J14	8.65mm x 6.00mm x 1.65mm
SOP14	8.70mm x 6.20mm x 1.71mm

Simplified Schematic

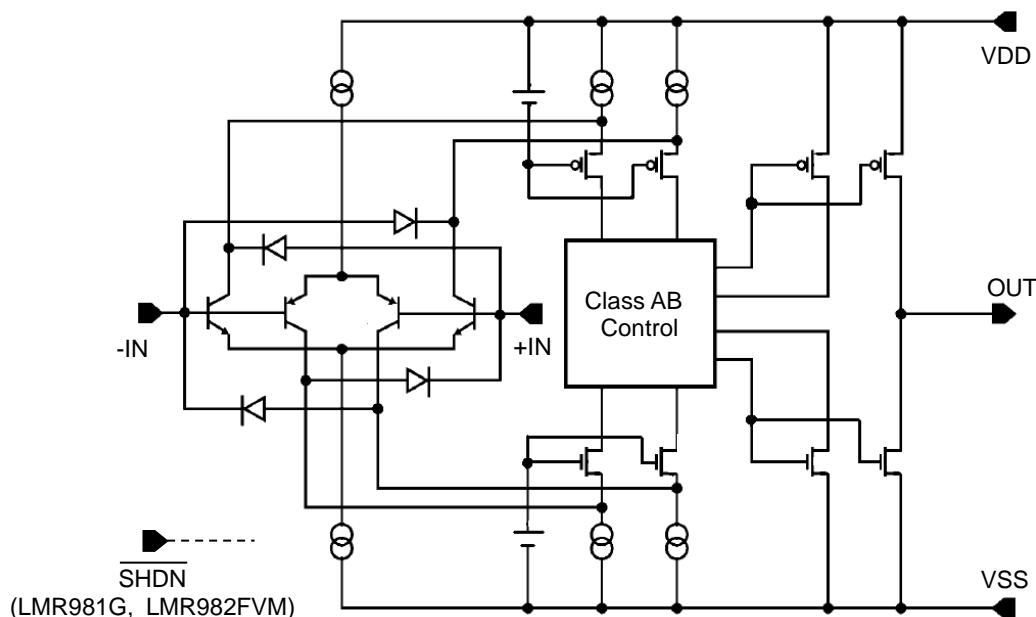
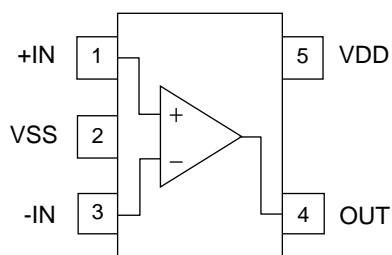

Figure 1. Simplified Schematic (1 Channel Only)

○Product structure : Silicon integrated circuit ○This product has no designed protection against radioactive rays.

Pin Configuration

LMR931G : SSOP5



Pin No.	Pin Name
1	+IN
2	VSS
3	-IN
4	OUT
5	VDD

LMR981G : SSOP6

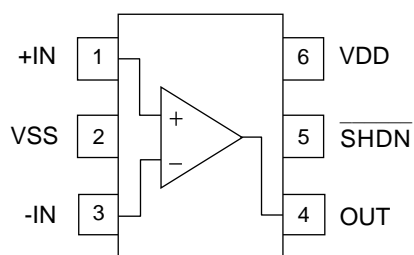

Pin No.	Pin Name
1	+IN
2	VSS
3	-IN
4	OUT
5	SHDN
6	VDD

- LMR932F : SOP8
- LMR932FJ : SOP-J8
- LMR932FV : SSOP-B8
- LMR932FVT : TSSOP-B8
- LMR932FVM : MSOP8
- LMR932FVJ : TSSOP-B8J

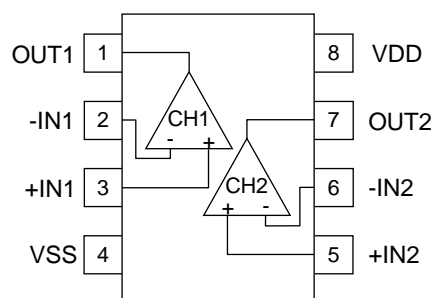

Pin No.	Pin Name
1	OUT1
2	-IN1
3	+IN1
4	VSS
5	+IN2
6	-IN2
7	OUT2
8	VDD

LMR934F : SOP14
 LMR934FJ : SOP-J14
 LMR934FV : SSOP-B14
 LMR934FVJ : TSSOP-B14J

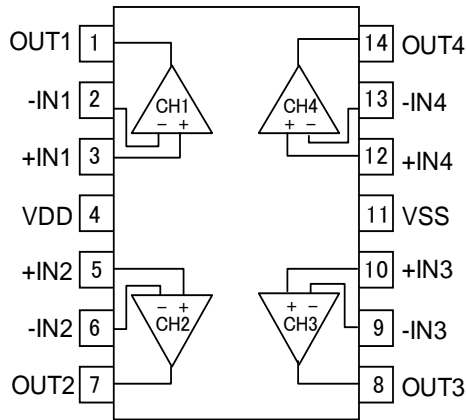

Pin No.	Pin Name
1	OUT1
2	-IN1
3	+IN1
4	VDD
5	+IN2
6	-IN2
7	OUT2
8	OUT3
9	-IN3
10	+IN3
11	VSS
12	+IN4
13	-IN4
14	OUT4

LMR982FVM : MSOP10

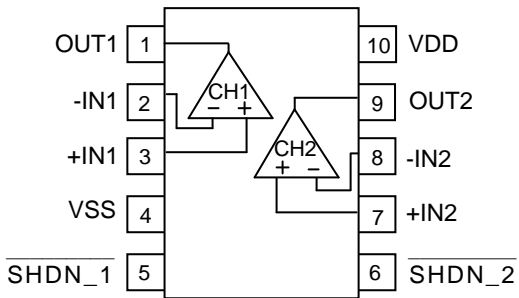

Pin No.	Pin Name
1	OUT1
2	-IN1
3	+IN1
4	VSS
5	SHDN_1
6	SHDN_2
7	+IN2
8	-IN2
9	OUT2
10	VDD

Package						
SSOP5	SSOP6	SOP8	SOP-J8	SSOP-B8	TSSOP-B8	MSOP8
LMR931G	LMR981G	LMR932F	LMR932FJ	LMR932FV	LMR932FVT	LMR932FVM
Package						
TSSOP-B8J	MSOP10	SOP14	SOP-J14	SSOP-B14	TSSOP-B14J	-
LMR932FVJ	LMR982FVM	LMR934F	LMR934FJ	LMR934FV	LMR934FVJ	-

Shutdown (LMR981G, LMR982FVM)

Pin	Input Condition	Shutdown Function
SHDN	VSS	ON
	VDD	OFF

Note: Please refer to Electrical Characteristics regarding the turn on and off voltage.

Ordering Information

L M R 9 x x x x x										-	X X	
Part Number					Package					Packaging and forming specification		
LMR931G					G : SSOP5					TR: Embossed tape and reel		
LMR981G					G : SSOP6					(SSOP5/SSOP6/MSOP8/MSOP10)		
LMR932F					F : SOP8					E2: Embossed tape and reel		
LMR932FJ					FJ : SOP-J8					(SOP8/SOP14/SOP-J8/SOP-J14		
LMR932FV					FV : SSOP-B8					SSOP-B8/SSOP-B14/TSSOP-B8/		
LMR932FVT					FVT : TSSOP-B8					TSSOP-B8J/TSSOP-B14J)		
LMR932FVM					FVM : MSOP8							
LMR932FVJ					FVJ : TSSOP-B8J							
LMR982FVM					FVM : MSOP10							
LMR934F					F : SOP14							
LMR934FJ					FJ : SOP-J14							
LMR934FV					FV : SSOP-B14							
LMR934FVJ					FVJ : TSSOP-B14J							

Lineup

Topr	Package		Operable Part Number
-40°C to +85°C	SSOP5	Reel of 3000	LMR931G-TR
	SSOP6	Reel of 3000	LMR981G-TR
	MSOP10	Reel of 3000	LMR982FVM-TR
	SOP8	Reel of 2500	LMR932F-E2
	SOP-J8	Reel of 2500	LMR932FJ-E2
	SSOP-B8	Reel of 2500	LMR932FV-E2
	TSSOP-B8	Reel of 3000	LMR932FVT-E2
	MSOP8	Reel of 3000	LMR932FVM-TR
	TSSOP-B8J	Reel of 2500	LMR932FVJ-E2
	SOP14	Reel of 2500	LMR934F-E2
	SOP-J14	Reel of 2500	LMR934FJ-E2
	SSOP-B14	Reel of 2500	LMR934FV-E2
	TSSOP-B14J	Reel of 2500	LMR934FVJ-E2

Absolute Maximum Ratings (T_A=25°C)

Parameter	Symbol	Rating					Unit
		LMR981G	LMR931G	LMR932xxx	LMR934xxx	LMR982FVM	
Supply Voltage	VDD-VSS	+7					V
Power Dissipation	P _D	SSOP5	-	0.67 ^(Note 1,9)	-	-	-
		SSOP6	0.67 ^(Note 1,9)	-	-	-	-
		SOP8	-	-	0.68 ^(Note 2,9)	-	-
		SOP-J8	-	-	0.67 ^(Note 1,9)	-	-
		SSOP-B8	-	-	0.62 ^(Note 5,9)	-	-
		TSSOP-B8	-	-	0.62 ^(Note 5,9)	-	-
		MSOP8	-	-	0.58 ^(Note 4,9)	-	-
		TSSOP-B8J	-	-	0.58 ^(Note 4,9)	-	-
		MSOP10	-	-	-	-	0.58 ^(Note 4,9)
		SOP14	-	-	-	0.56 ^(Note 3,9)	-
		SOP-J14	-	-	-	1.02 ^(Note 8,9)	-
		SSOP-B14	-	-	-	0.87 ^(Note 7,9)	-
TSSOP-B14J	-	-	-	0.85 ^(Note 6,9)	-		
Differential Input Voltage ^(Note 10)	V _{ID}	VDD to VSS					V
Input Common-mode Voltage Range	V _{ICM}	(VSS-0.3) to (VDD+0.3)					V
Input Current ^(Note 11)	I _I	±10					mA
Operating Voltage	V _{opr}	+1.8 to +5.0					V
Operating Temperature	T _{opr}	- 40 to +85					°C
Storage Temperature	T _{stg}	- 55 to +150					°C
Maximum Junction Temperature	T _{Jmax}	+150					°C

(Note 1) To use at temperature above T_A=25°C reduce 5.4mW/°C.

(Note 2) To use at temperature above T_A=25°C reduce 5.5mW/°C.

(Note 3) To use at temperature above T_A=25°C reduce 4.5mW/°C.

(Note 4) To use at temperature above T_A=25°C reduce 4.7mW/°C.

(Note 5) To use at temperature above T_A=25°C reduce 5.0mW/°C.

(Note 6) To use at temperature above T_A=25°C reduce 6.8mW/°C.

(Note 7) To use at temperature above T_A=25°C reduce 7.0mW/°C.

(Note 8) To use at temperature above T_A=25°C reduce 8.2mW/°C.

(Note 9) Mounted on a FR4 glass epoxy PCB 70mm×70mm×1.6mm (Copper foil area less than 3%).

(Note 10) The voltage difference between inverting input and non-inverting input is the differential input voltage.

Then input terminal voltage is set to more than VSS.

(Note 11) An excessive input current will flow when input voltages of more than VDD+0.6V or less than VSS-0.6V are applied.

The input current can be set to less than the rated current by adding a limiting resistor.

Caution: Operating the IC over the absolute maximum ratings may damage the IC. The damage can either be a short circuit between pins or an open circuit between pins and the internal circuitry. Therefore, it is important to consider circuit protection measures, such as adding a fuse, in case the IC is operated over the absolute maximum ratings.

Electrical Characteristics:

○LMR981G, LMR931G (Unless otherwise specified VDD=+1.8V, VSS=0V, SHDN=VDD)

Parameter	Symbol	Temperature Range	Limit			Unit	Conditions
			Min	Typ	Max		
Input Offset Voltage (Note 12)	V _{IO}	25°C	-	1	4	mV	VDD=1.8V to 5.0V
		Full Range	-	-	6		
Input Offset Voltage Drift	ΔV _{IO} /ΔT	25°C	-	5.5	-	μV/°C	-
Input Offset Current (Note 12)	I _{IO}	25°C	-	5	30	nA	-
Input Bias Current (Note 12)	I _B	25°C	-	5	35	nA	-
Supply Current (Note 13)	I _{DD}	25°C	-	75	180	μA	A _V =0dB, +IN=0.9V
		Full range	-	-	205		
Shutdown Current (Note 14)	I _{DD_SD}	25°C	-	0.15	1	μA	SHDN=0V
Maximum Output Voltage(High)	V _{OH}	25°C	1.65	1.72	-	V	R _L =600Ω, V _{RL} =VDD/2
			1.75	1.77	-		R _L =2kΩ, V _{RL} =VDD/2
Maximum Output Voltage(Low)	V _{OL}	25°C	-	77	105	mV	R _L =600Ω, V _{RL} =VDD/2
			-	24	35		R _L =2kΩ, V _{RL} =VDD/2
Large Signal Voltage Gain	A _V	25°C	-	96	-	dB	R _L =600Ω, V _{RL} =VDD/2
			80	100	-		R _L =2kΩ, V _{RL} =VDD/2
Input Common-mode Voltage Range	V _{ICM}	25°C	VSS	-	VDD	V	VSS to VDD
		Full range	VSS+0.2	-	VDD-0.2		
Common-mode Rejection Ratio	CMRR	25°C	60	94	-	dB	V _{ICM} =0.5V
Power Supply Rejection Ratio	PSRR	25°C	75	85	-	dB	VDD=1.8V to 5.0V V _{ICM} =0.5V
Output Source Current (Note 15)	I _{SOURCE}	25°C	4	8	-	mA	OUT=0V, Short Current
Output Sink Current (Note 15)	I _{SINK}	25°C	7	9	-	mA	OUT=1.8V Short Current
Slew Rate	SR	25°C	-	0.35	-	V/μs	C _L =25pF
Gain Bandwidth	GBW	25°C	-	1.4	-	MHz	C _L =25pF, A _V =40dB f=100kHz
Unity Gain Frequency	f _T	25°C	-	1.4	-	MHz	C _L =25pF, A _V =40dB
Phase Margin	θ	25°C	-	50	-	deg	C _L =25pF, A _V =40dB
Gain Margin	GM	25°C	-	7	-	dB	C _L =25pF, A _V =40dB
Input Referred Noise Voltage	V _N	25°C	-	6.5	-	μV _{rms}	A _V =40dB, DIN-AUDIO
			-	50	-	nV/√Hz	f=10kHz
Total Harmonic Distortion + Noise	THD+N	25°C	-	0.023	-	%	OUT=1V _{P-P} , f=1kHz R _L =600Ω, A _V =0dB

(Note 12) Absolute value.

(Note 13) Full range: T_A=-40°C to +85°C

(Note 14) Only LMR981G have shutdown.

(Note 15) Under the high temperature environment, consider the power dissipation of IC when selecting the output current.

When the terminal short circuits are continuously output, the output current is reduced to climb to the temperature inside IC.

○LMR981G (Unless otherwise specified VDD=+1.8V, VSS=0V)

Parameter	Symbol	Temperature Range	Limit			Unit	Conditions
			Min	Typ	Max		
Turn On Time From Shutdown	t _{ON}	25°C	-	19	-	μs	V _{ICM} = VDD/2
Turn On Voltage High	V _{SHDN_H}	25°C	-	1.32	-	V	-
Turn On Voltage Low	V _{SHDN_L}		-	0.72	-		-

Electrical Characteristics - continued

○LMR981G, LMR931G (Unless otherwise specified VDD=+2.7V, VSS=0V, SHDN=VDD)

Parameter	Symbol	Temperature Range	Limit			Unit	Conditions
			Min	Typ	Max		
Input Offset Voltage (Note 16)	V _{IO}	25°C	-	1	4	mV	VDD=1.8V to 5.0V
		Full Range	-	-	6		
Input Offset Voltage Drift	ΔV _{IO} /ΔT	25°C	-	5.5	-	μV/°C	-
Input Offset Current (Note 16)	I _{IO}	25°C	-	5	30	nA	-
Input Bias Current (Note 16)	I _B	25°C	-	5	35	nA	-
Supply Current (Note 17)	I _{DD}	25°C	-	80	190	μA	A _V =0dB, +IN=1.35V
		Full range	-	-	210		
Shutdown Current (Note 18)	I _{DD_SD}	25°C	-	0.061	1	μA	SHDN=0V
Maximum Output Voltage(High)	V _{OH}	25°C	2.55	2.62	-	V	R _L =600Ω, V _{RL} =VDD/2
			2.65	2.67	-		R _L =2kΩ, V _{RL} =VDD/2
Maximum Output Voltage(Low)	V _{OL}	25°C	-	83	110	mV	R _L =600Ω, V _{RL} =VDD/2
			-	25	40		R _L =2kΩ, V _{RL} =VDD/2
Large Signal Voltage Gain	A _V	25°C	-	98	-	dB	R _L =600Ω, V _{RL} =VDD/2
			92	100	-		R _L =2kΩ, V _{RL} =VDD/2
Input Common-mode Voltage Range	V _{ICM}	25°C	VSS	-	VDD	V	VSS to VDD
		Full range	VSS+0.2	-	VDD-0.2		
Common-mode Rejection Ratio	CMRR	25°C	60	94	-	dB	V _{ICM} =0.5V
Power Supply Rejection Ratio	PSRR	25°C	75	85	-	dB	VDD=1.8V to 5.0V V _{ICM} =0.5V
Output Source Current (Note 19)	I _{SOURCE}	25°C	20	28	-	mA	OUT=0V, Short Current
Output Sink Current (Note 19)	I _{SINK}	25°C	18	28	-	mA	OUT=2.7V Short Current
Slew Rate	SR	25°C	-	0.4	-	V/μs	C _L =25pF
Gain Bandwidth	GBW	25°C	-	1.4	-	MHz	C _L =25pF, A _V =40dB f=100kHz
Unity Gain Frequency	f _T	25°C	-	1.4	-	MHz	C _L =25pF, A _V =40dB
Phase Margin	θ	25°C	-	50	-	deg	C _L =25pF, A _V =40dB
Gain Margin	GM	25°C	-	7	-	dB	C _L =25pF, A _V =40dB
Input Referred Noise Voltage	V _N	25°C	-	6.5	-	μVrms	A _V =40dB, DIN-AUDIO
			-	50	-	nV/√Hz	f=10kHz
Total Harmonic Distortion + Noise	THD+N	25°C	-	0.022	-	%	OUT=1V _{P-P} , f=1kHz R _L =600Ω, A _V =0dB

(Note 16) Absolute value.

(Note 17) Full range: T_A=-40°C to +85°C

(Note 18) Only LMR981G have shutdown.

(Note 19) Under the high temperature environment, consider the power dissipation of IC when selecting the output current.

When the terminal short circuits are continuously output, the output current is reduced to climb to the temperature inside IC.

○LMR981G (Unless otherwise specified VDD=+2.7V, VSS=0V)

Parameter	Symbol	Temperature Range	Limit			Unit	Conditions
			Min	Typ	Max		
Turn On Time From Shutdown	t _{ON}	25°C	-	12.5	-	μs	V _{ICM} = VDD/2
Turn On Voltage High	V _{SHDN_H}	25°C	-	1.63	-	V	-
Turn On Voltage Low	V _{SHDN_L}		-	1.35	-		-

Electrical Characteristics - continued

○LMR981G, LMR931G (Unless otherwise specified VDD=+5.0V, VSS=0V, SHDN=VDD)

Parameter	Symbol	Temperature Range	Limit			Unit	Conditions
			Min	Typ	Max		
Input Offset Voltage (Note 20)	V _{IO}	25°C	-	1	4	mV	VDD=1.8V to 5.0V
		Full Range	-	-	6		
Input Offset Voltage Drift	ΔV _{IO} /ΔT	25°C	-	5.5	-	μV/°C	-
Input Offset Current (Note 20)	I _{IO}	25°C	-	5	30	nA	-
Input Bias Current (Note 20)	I _B	25°C	-	5	35	nA	-
Supply Current (Note 21)	I _{DD}	25°C	-	85	200	μA	A _V =0dB, +IN=2.5V
		Full range	-	-	230		
Shutdown Current (Note 22)	I _{DD_SD}	25°C	-	0.2	1	μA	SHDN=0V
Maximum Output Voltage(High)	V _{OH}	25°C	4.85	4.89	-	V	R _L =600Ω, V _{RL} =VDD/2
			4.94	4.96	-		R _L =2kΩ, V _{RL} =VDD/2
Maximum Output Voltage(Low)	V _{OL}	25°C	-	120	160	mV	R _L =600Ω, V _{RL} =VDD/2
			-	37	65		R _L =2kΩ, V _{RL} =VDD/2
Large Signal Voltage Gain	A _V	25°C	-	101	-	dB	R _L =600Ω, V _{RL} =VDD/2
			94	105	-		R _L =2kΩ, V _{RL} =VDD/2
Input Common-mode Voltage Range	V _{ICM}	25°C	VSS	-	VDD	V	VSS to VDD
		Full range	VSS+0.2	-	VDD-0.2		
Common-mode Rejection Ratio	CMRR	25°C	60	94	-	dB	V _{ICM} =0.5V
Power Supply Rejection Ratio	PSRR	25°C	75	85	-	dB	VDD=1.8V to 5.0V V _{ICM} =0.5V
Output Source Current (Note 23)	I _{SOURCE}	25°C	80	90	-	mA	OUT=0V, Short Current
Output Sink Current (Note 23)	I _{SINK}	25°C	58	80	-	mA	OUT=5V Short Current
Slew Rate	SR	25°C	-	0.42	-	V/μs	C _L =25pF
Gain Bandwidth	GBW	25°C	-	1.5	-	MHz	C _L =25pF, A _V =40dB f=100kHz
Unity Gain Frequency	f _t	25°C	-	1.5	-	MHz	C _L =25pF, A _V =40dB
Phase Margin	θ	25°C	-	50	-	deg	C _L =25pF, A _V =40dB
Gain Margin	GM	25°C	-	7	-	dB	C _L =25pF, A _V =40dB
Input Referred Noise Voltage	V _N	25°C	-	6.5	-	μV _{rms}	A _V =40dB, DIN-AUDIO
			-	50	-	nV/√Hz	f=10kHz
Total Harmonic Distortion + Noise	THD+N	25°C	-	0.022	-	%	OUT=1V _{P-P} , f=1kHz R _L =600Ω, A _V =0dB

(Note 20) Absolute value

(Note 21) Full range: T_A=-40°C to +85°C

(Note 22) Only LMR981G have shutdown.

(Note 23) Under the high temperature environment, consider the power dissipation of IC when selecting the output current.

When the terminal short circuits are continuously output, the output current is reduced to climb to the temperature inside IC.

○LMR981G (Unless otherwise specified VDD=+5.0V, VSS=0V)

Parameter	Symbol	Temperature Range	Limit			Unit	Conditions
			Min	Typ	Max		
Turn On Time From Shutdown	t _{ON}	25°C	-	8.4	-	μs	V _{ICM} = VDD/2
Turn On Voltage High	V _{SHDN_H}	25°C	-	2.98	-	V	-
Turn On Voltage Low	V _{SHDN_L}		-	2.70	-		-

Electrical Characteristics - continued

○LMR982FVM, LMR932xxx (Unless otherwise specified VDD=+1.8V, VSS=0V, $\overline{\text{SHDN}}=\text{VDD}$ *LMR982FVM only)

Parameter	Symbol	Temperature Range	Limit			Unit	Conditions
			Min	Typ	Max		
Input Offset Voltage (Note 24)	V _{IO}	25°C	-	1	5.5	mV	VDD=1.8V to 5.0V
		Full Range	-	-	7.5		
Input Offset Voltage Drift	ΔV _{IO} /ΔT	25°C	-	5.5	-	μV/°C	-
Input Offset Current (Note 24)	I _{IO}	25°C	-	5	30	nA	-
Input Bias Current (Note 24)	I _B	25°C	-	5	35	nA	-
Supply Current (Note 25)	I _{DD}	25°C	-	135	290	μA	A _V =0dB, +IN=0.9V
		Full range	-	-	410		
Shutdown Current (Note 26)	I _{DD_SD}	25°C	-	0.15	1	μA	$\overline{\text{SHDN}}=0\text{V}$
Maximum Output Voltage(High)	V _{OH}	25°C	1.65	1.72	-	V	R _L =600Ω, V _{RL} =VDD/2
			1.75	1.77	-		R _L =2kΩ, V _{RL} =VDD/2
Maximum Output Voltage(Low)	V _{OL}	25°C	-	77	105	mV	R _L =600Ω, V _{RL} =VDD/2
			-	24	35		R _L =2kΩ, V _{RL} =VDD/2
Large Signal Voltage Gain	A _V	25°C	-	94	-	dB	R _L =600Ω, V _{RL} =VDD/2
			80	100	-		R _L =2kΩ, V _{RL} =VDD/2
Input Common-mode Voltage Range	V _{ICM}	25°C	VSS	-	VDD	V	VSS to VDD
		Full range	VSS+0.2	-	VDD-0.2		
Common-mode Rejection Ratio	CMRR	25°C	60	94	-	dB	V _{ICM} =0.5V
Power Supply Rejection Ratio	PSRR	25°C	75	85	-	dB	VDD=1.8V to 5.0V V _{ICM} =0.5V
Output Source Current (Note 27)	I _{SOURCE}	25°C	4	8	-	mA	OUT=0V, Short Current
Output Sink Current (Note 27)	I _{SINK}	25°C	7	9	-	mA	OUT=1.8V Short Current
Slew Rate	SR	25°C	-	0.35	-	V/μs	C _L =25pF
Gain Bandwidth	GBW	25°C	-	1.4	-	MHz	C _L =25pF, A _V =40dB f=100kHz
Unity Gain Frequency	f _T	25°C	-	1.4	-	MHz	C _L =25pF, A _V =40dB
Phase Margin	θ	25°C	-	50	-	deg	C _L =25pF, A _V =40dB
Gain Margin	GM	25°C	-	7	-	dB	C _L =25pF, A _V =40dB
Input Referred Noise Voltage	V _N	25°C	-	6.5	-	μVrms	A _V =40dB, DIN-AUDIO
			-	50	-	nV/√Hz	f=10kHz
Total Harmonic Distortion + Noise	THD+N	25°C	-	0.023	-	%	OUT=1V _{P-P} , f=1kHz R _L =600Ω, A _V =0dB
Channel Separation	CS	25°C	-	110	-	dB	A _V =40dB, OUT=1Vrms

(Note 24) Absolute value.

(Note 25) Full range: T_A=-40°C to +85°C

(Note 26) Only LMR982FVM have shutdown.

(Note 27) Under the high temperature environment, consider the power dissipation of IC when selecting the output current.

When the terminal short circuits are continuously output, the output current is reduced to climb to the temperature inside IC.

○LMR982FVM (Unless otherwise specified VDD=+1.8V, VSS=0V)

Parameter	Symbol	Temperature Range	Limit			Unit	Conditions
			Min	Typ	Max		
Turn On Time From Shutdown	t _{ON}	25°C	-	19	-	μs	V _{ICM} = VDD/2
Turn On Voltage High	V _{SHDN_H}	25°C	-	1.32	-	V	-
Turn On Voltage Low	V _{SHDN_L}		-	0.72	-		-

Electrical Characteristics - continued

○LMR982FVM, LMR932xxx (Unless otherwise specified VDD=+2.7V, VSS=0V, $\overline{\text{SHDN}}=\text{VDD}$)

Parameter	Symbol	Temperature Range	Limit			Unit	Conditions
			Min	Typ	Max		
Input Offset Voltage (Note 28)	V _{IO}	25°C	-	1	5.5	mV	VDD=1.8V to 5.0V
		Full Range	-	-	7.5		
Input Offset Voltage Drift	$\Delta V_{IO}/\Delta T$	25°C	-	5.5	-	$\mu\text{V}/^\circ\text{C}$	-
Input Offset Current (Note 28)	I _{IO}	25°C	-	5	30	nA	-
Input Bias Current (Note 28)	I _B	25°C	-	5	35	nA	-
Supply Current (Note 29)	I _{DD}	25°C	-	135	300	μA	A _V =0dB, +IN=1.35V
		Full range	-	-	420		
Shutdown Current (Note 30)	I _{DD_SD}	25°C	-	0.061	1	μA	$\overline{\text{SHDN}}=0\text{V}$
Maximum Output Voltage(High)	V _{OH}	25°C	2.55	2.62	-	V	R _L =600 Ω , V _{RL} =VDD/2
			2.65	2.67	-		R _L =2k Ω , V _{RL} =VDD/2
Maximum Output Voltage(Low)	V _{OL}	25°C	-	83	110	mV	R _L =600 Ω , V _{RL} =VDD/2
			-	25	40		R _L =2k Ω , V _{RL} =VDD/2
Large Signal Voltage Gain	A _V	25°C	-	98	-	dB	R _L =600 Ω , V _{RL} =VDD/2
			92	100	-		R _L =2k Ω , V _{RL} =VDD/2
Input Common-mode Voltage Range	V _{ICM}	25°C	VSS	-	VDD	V	VSS to VDD
		Full range	VSS+0.2	-	VDD-0.2		
Common-mode Rejection Ratio	CMRR	25°C	60	94	-	dB	V _{ICM} =0.5V
Power Supply Rejection Ratio	PSRR	25°C	75	85	-	dB	VDD=1.8V to 5.0V V _{ICM} =0.5V
Output Source Current (Note 31)	I _{SOURCE}	25°C	20	28	-	mA	OUT=0V, Short Current
Output Sink Current (Note 31)	I _{SINK}	25°C	18	28	-	mA	OUT=2.7V Short Current
Slew Rate	SR	25°C	-	0.4	-	V/ μs	C _L =25pF
Gain Bandwidth	GBW	25°C	-	1.4	-	MHz	C _L =25pF, A _V =40dB f=100kHz
Unity Gain Frequency	f _T	25°C	-	1.4	-	MHz	C _L =25pF, A _V =40dB
Phase Margin	θ	25°C	-	50	-	deg	C _L =25pF, A _V =40dB
Gain Margin	GM	25°C	-	7	-	dB	C _L =25pF, A _V =40dB
Input Referred Noise Voltage	V _N	25°C	-	6.5	-	μVrms	A _V =40dB, DIN-AUDIO
			-	50	-	nV/ $\sqrt{\text{Hz}}$	f=10kHz
Total Harmonic Distortion + Noise	THD+N	25°C	-	0.022	-	%	OUT=1V _{P-P} , f=1kHz R _L =600 Ω , A _V =0dB
Channel Separation	CS	25°C	-	110	-	dB	A _V =40dB, OUT=1Vrms

(Note 28) Absolute value.

(Note 29) Full range: T_A=-40°C to +85°C

(Note 30) Only LMR982FVM have shutdown.

(Note 31) Under the high temperature environment, consider the power dissipation of IC when selecting the output current.

When the terminal short circuits are continuously output, the output current is reduced to climb to the temperature inside IC.

○LMR982FVM (Unless otherwise specified VDD=+2.7V, VSS=0V)

Parameter	Symbol	Temperature Range	Limit			Unit	Conditions
			Min	Typ	Max		
Turn On Time From Shutdown	t _{ON}	25°C	-	12.5	-	μs	V _{ICM} = VDD/2
Turn On Voltage High	V _{SHDN_H}	25°C	-	1.63	-	V	-
Turn On Voltage Low	V _{SHDN_L}		-	1.35	-		-

Electrical Characteristics - continued

○LMR982FVM, LMR932xxx (Unless otherwise specified VDD=+5.0V, VSS=0V, $\overline{\text{SHDN}}=\text{VDD}$)

Parameter	Symbol	Temperature Range	Limit			Unit	Conditions
			Min	Typ	Max		
Input Offset Voltage (Note 32)	V _{IO}	25°C	-	1	5.5	mV	VDD=1.8V to 5.0V
		Full Range	-	-	7.5		
Input Offset Voltage Drift	ΔV _{IO} /ΔT	25°C	-	5.5	-	μV/°C	-
Input Offset Current (Note 32)	I _{IO}	25°C	-	5	30	nA	-
Input Bias Current (Note 32)	I _B	25°C	-	5	35	nA	-
Supply Current (Note 33)	I _{DD}	25°C	-	140	300	μA	A _V =0dB, +IN=2.5V
		Full range	-	-	460		
Shutdown Current (Note 34)	I _{DD_SD}	25°C	-	0.2	1	μA	$\overline{\text{SHDN}}=0\text{V}$
Maximum Output Voltage(High)	V _{OH}	25°C	4.85	4.89	-	V	R _L =600Ω, V _{RL} =VDD/2
			4.94	4.96	-		R _L =2kΩ, V _{RL} =VDD/2
Maximum Output Voltage(Low)	V _{OL}	25°C	-	120	160	mV	R _L =600Ω, V _{RL} =VDD/2
			-	37	65		R _L =2kΩ, V _{RL} =VDD/2
Large Signal Voltage Gain	A _V	25°C	-	101	-	dB	R _L =600Ω, V _{RL} =VDD/2
			94	105	-		R _L =2kΩ, V _{RL} =VDD/2
Input Common-mode Voltage Range	V _{ICM}	25°C	VSS	-	VDD	V	VSS to VDD
		Full range	VSS+0.2	-	VDD-0.2		
Common-mode Rejection Ratio	CMRR	25°C	60	94	-	dB	V _{ICM} =0.5V
Power Supply Rejection Ratio	PSRR	25°C	75	85	-	dB	VDD=1.8V to 5.0V V _{ICM} =0.5V
Output Source Current (Note 35)	I _{SOURCE}	25°C	80	90	-	mA	OUT=0V, Short Current
Output Sink Current (Note 35)	I _{SINK}	25°C	58	80	-	mA	OUT=5V Short Current
Slew Rate	SR	25°C	-	0.42	-	V/μs	C _L =25pF
Gain Bandwidth	GBW	25°C	-	1.5	-	MHz	C _L =25pF, A _V =40dB f=100kHz
Unity Gain Frequency	f _T	25°C	-	1.5	-	MHz	C _L =25pF, A _V =40dB
Phase Margin	θ	25°C	-	50	-	deg	C _L =25pF, A _V =40dB
Gain Margin	GM	25°C	-	7	-	dB	C _L =25pF, A _V =40dB
Input Referred Noise Voltage	V _N	25°C	-	6.5	-	μVrms	A _V =40dB, DIN-AUDIO
			-	50	-	nV/√Hz	f=10kHz
Total Harmonic Distortion + Noise	THD+N	25°C	-	0.022	-	%	OUT=1V _{P-P} , f=1kHz R _L =600Ω, A _V =0dB
Channel Separation	CS	25°C	-	110	-	dB	A _V =40dB, OUT=1Vrms

(Note 32) Absolute value

(Note 33) Full range: T_A=-40°C to +85°C

(Note 34) Only LMR982FVM have shutdown.

(Note 35) Under the high temperature environment, consider the power dissipation of IC when selecting the output current.

When the terminal short circuits are continuously output, the output current is reduced to climb to the temperature inside IC.

○LMR982FVM (Unless otherwise specified VDD=+5.0V, VSS=0V)

Parameter	Symbol	Temperature Range	Limit			Unit	Conditions
			Min	Typ	Max		
Turn On Time From Shutdown	t _{ON}	25°C	-	8.4	-	μs	V _{ICM} = VDD/2
Turn On Voltage High	V _{SHDN_H}	25°C	-	2.98	-	V	-
Turn On Voltage Low	V _{SHDN_L}		-	2.70	-		-

Electrical Characteristics - continued

○LMR934xxx (Unless otherwise specified VDD=+1.8V, VSS=0V)

Parameter	Symbol	Temperature Range	Limits			Unit	Condition
			Min	Typ	Max		
Input Offset Voltage (Note 36)	V _{IO}	25°C	-	1	5.5	mV	VDD=1.8V to 5.0V
		Full Range	-	-	7.5		
Input Offset Voltage Drift	ΔV _{IO} /ΔT	25°C	-	5.5	-	μV/°C	-
Input Offset Current (Note 36)	I _{IO}	25°C	-	5	30	nA	-
Input Bias Current (Note 36)	I _B	25°C	-	5	35	nA	-
Supply Current (Note 37)	I _{DD}	25°C	-	280	550	μA	A _v =0dB, +IN=0.9V
		Full range	-	-	820		
Maximum Output Voltage(High)	V _{OH}	25°C	1.65	1.72	-	V	R _L =600Ω, V _{RL} =VDD/2
			1.75	1.77	-		R _L =2kΩ, V _{RL} =VDD/2
Maximum Output Voltage(Low)	V _{OL}	25°C	-	77	105	mV	R _L =600Ω, V _{RL} =VDD/2
			-	24	35		R _L =2kΩ, V _{RL} =VDD/2
Large Signal Voltage Gain	A _v	25°C	-	96	-	dB	R _L =600Ω, V _{RL} =VDD/2
			80	100	-		R _L =2kΩ, V _{RL} =VDD/2
Input Common-mode Voltage Range	V _{ICM}	25°C	VSS	-	VDD	V	VSS to VDD
		Full range	VSS+0.2	-	VDD-0.2		
Common-mode Rejection Ratio	CMRR	25°C	60	94	-	dB	V _{ICM} =0.5V
Power Supply Rejection Ratio	PSRR	25°C	75	85	-	dB	VDD=1.8V to 5.0V V _{ICM} =0.5V
Output Source Current (Note 38)	I _{SOURCE}	25°C	4	8	-	mA	OUT=0V, Short Current
Output Sink Current (Note 38)	I _{SINK}	25°C	7	9	-	mA	OUT=1.8V Short Current
Slew Rate	SR	25°C	-	0.35	-	V/μs	C _L =25pF
Gain Bandwidth	GBW	25°C	-	1.4	-	MHz	C _L =25pF, A _v =40dB f=100kHz
Unity Gain Frequency	f _T	25°C	-	1.4	-	MHz	C _L =25pF, A _v =40dB
Phase Margin	θ	25°C	-	50	-	deg	C _L =25pF, A _v =40dB
Gain Margin	GM	25°C	-	7	-	dB	C _L =25pF, A _v =40dB
Input Referred Noise Voltage	V _N	25°C	-	6.5	-	μVrms	A _v =40dB, DIN-AUDIO
			-	50	-	nV/√Hz	f=10kHz
Total Harmonic Distortion + Noise	THD+N	25°C	-	0.023	-	%	OUT=1V _{P-P} , f=1kHz R _L =600Ω, A _v =0dB
Channel Separation	CS	25°C	-	110	-	dB	A _v =40dB, OUT=1Vrms

(Note 36) Absolute value.

(Note 37) Full range: T_A=-40°C to +85°C

(Note 38) Under the high temperature environment, consider the power dissipation of IC when selecting the output current.

When the terminal short circuits are continuously output, the output current is reduced to climb to the temperature inside IC.

Electrical Characteristics - continued

○LMR934xxx (Unless otherwise specified VDD=+2.7V, VSS=0V)

Parameter	Symbol	Temperature Range	Limit			Unit	Conditions
			Min	Typ	Max		
Input Offset Voltage (Note 39)	V _{IO}	25°C	-	1	5.5	mV	VDD=1.8V to 5.0V
		Full Range	-	-	7.5		
Input Offset Voltage Drift	ΔV _{IO} /ΔT	25°C	-	5.5	-	μV/°C	-
Input Offset Current (Note 39)	I _{IO}	25°C	-	5	30	nA	-
Input Bias Current (Note 39)	I _B	25°C	-	5	35	nA	-
Supply Current (Note 40)	I _{DD}	25°C	-	250	600	μA	A _V =0dB, +IN=1.35V
		Full range	-	-	840		
Maximum Output Voltage(High)	V _{OH}	25°C	2.55	2.62	-	V	R _L =600Ω, V _{RL} =VDD/2
			2.65	2.67	-		R _L =2kΩ, V _{RL} =VDD/2
Maximum Output Voltage(Low)	V _{OL}	25°C	-	83	110	mV	R _L =600Ω, V _{RL} =VDD/2
			-	25	40		R _L =2kΩ, V _{RL} =VDD/2
Large Signal Voltage Gain	A _V	25°C	-	98	-	dB	R _L =600Ω, V _{RL} =VDD/2
			92	100	-		R _L =2kΩ, V _{RL} =VDD/2
Input Common-mode Voltage Range	V _{ICM}	25°C	VSS	-	VDD	V	VSS to VDD
		Full range	VSS+0.2	-	VDD-0.2		
Common-mode Rejection Ratio	CMRR	25°C	60	94	-	dB	V _{ICM} =0.5V
Power Supply Rejection Ratio	PSRR	25°C	75	85	-	dB	VDD=1.8V to 5.0V V _{ICM} =0.5V
Output Source Current (Note 41)	I _{SOURCE}	25°C	20	28	-	mA	OUT=0V, Short Current
Output Sink Current (Note 41)	I _{SINK}	25°C	18	28	-	mA	OUT=2.7V Short Current
Slew Rate	SR	25°C	-	0.4	-	V/μs	C _L =25pF
Gain Bandwidth	GBW	25°C	-	1.4	-	MHz	C _L =25pF, A _V =40dB f=100kHz
Unity Gain Frequency	f _T	25°C	-	1.4	-	MHz	C _L =25pF, A _V =40dB
Phase Margin	θ	25°C	-	50	-	deg	C _L =25pF, A _V =40dB
Gain Margin	GM	25°C	-	7	-	dB	C _L =25pF, A _V =40dB
Input Referred Noise Voltage	V _N	25°C	-	6.5	-	μVrms	A _V =40dB, DIN-AUDIO
			-	50	-	nV/√Hz	f=10kHz
Total Harmonic Distortion + Noise	THD+N	25°C	-	0.022	-	%	OUT=1V _{P-P} , f=1kHz R _L =600Ω, A _V =0dB
Channel Separation	CS	25°C	-	110	-	dB	A _V =40dB, OUT=1Vrms

(Note 39) Absolute value.

(Note 40) Full range: T_A=-40°C to +85°C

(Note 41) Under the high temperature environment, consider the power dissipation of IC when selecting the output current.

When the terminal short circuits are continuously output, the output current is reduced to climb to the temperature inside IC.

Electrical Characteristics - continued

○ LMR934xxx (Unless otherwise specified VDD=+5.0V, VSS=0V)

Parameter	Symbol	Temperature Range	Limit			Unit	Conditions
			Min	Typ	Max		
Input Offset Voltage (Note 42)	V _{IO}	25°C	-	1	5.5	mV	VDD=1.8V to 5.0V
		Full Range	-	-	7.5		
Input Offset Voltage Drift	ΔV _{IO} /ΔT	25°C	-	5.5	-	μV/°C	-
Input Offset Current (Note 42)	I _{IO}	25°C	-	5	30	nA	-
Input Bias Current (Note 42)	I _B	25°C	-	5	35	nA	-
Supply Current (Note 43)	I _{DD}	25°C	-	290	600	μA	A _V =0dB, +IN=2.5V
		Full range	-	-	920		
Maximum Output Voltage(High)	V _{OH}	25°C	4.85	4.89	-	V	R _L =600Ω, V _{RL} =VDD/2
			4.94	4.96	-		R _L =2kΩ, V _{RL} =VDD/2
Maximum Output Voltage(Low)	V _{OL}	25°C	-	120	160	mV	R _L =600Ω, V _{RL} =VDD/2
			-	37	65		R _L =2kΩ, V _{RL} =VDD/2
Large Signal Voltage Gain	A _V	25°C	-	101	-	dB	R _L =600Ω, V _{RL} =VDD/2
			94	105	-		R _L =2kΩ, V _{RL} =VDD/2
Input Common-mode Voltage Range	V _{ICM}	25°C	VSS	-	VDD	V	VSS to VDD
		Full range	VSS+0.2	-	VDD-0.2		
Common-mode Rejection Ratio	CMRR	25°C	60	94	-	dB	V _{ICM} =0.5V
Power Supply Rejection Ratio	PSRR	25°C	75	85	-	dB	VDD=1.8V to 5.0V V _{ICM} =0.5V
Output Source Current (Note 44)	I _{SOURCE}	25°C	80	90	-	mA	OUT=0V, Short Current
Output Sink Current (Note 44)	I _{SINK}	25°C	58	80	-	mA	OUT=5V Short Current
Slew Rate	SR	25°C	-	0.42	-	V/μs	C _L =25pF
Gain Bandwidth	GBW	25°C	-	1.5	-	MHz	C _L =25pF, A _V =40dB f=100kHz
Unity Gain Frequency	f _T	25°C	-	1.5	-	MHz	C _L =25pF, A _V =40dB
Phase Margin	θ	25°C	-	50	-	deg	C _L =25pF, A _V =40dB
Gain Margin	GM	25°C	-	7	-	dB	C _L =25pF, A _V =40dB
Input Referred Noise Voltage	V _N	25°C	-	6.5	-	μVrms	A _V =40dB, DIN-AUDIO
			-	50	-	nV/√Hz	f=10kHz
Total Harmonic Distortion + Noise	THD+N	25°C	-	0.022	-	%	OUT=1V _{P-P} , f=1kHz R _L =600Ω, A _V =0dB
Channel Separation	CS	25°C	-	110	-	dB	A _V =40dB, OUT=1Vrms

(Note 42) Absolute value

(Note 43) Full range: T_A=-40°C to +85°C

(Note 44) Under the high temperature environment, consider the power dissipation of IC when selecting the output current.

When the terminal short circuits are continuously output, the output current is reduced to climb to the temperature inside IC.

Description of Electrical Characteristics

Described below are descriptions of the relevant electrical terms used in this datasheet. Items and symbols used are also shown. Note that item name and symbol and their meaning may differ from those on another manufacturer's document or general document.

1. Absolute maximum ratings

Absolute maximum rating items indicate the condition which must not be exceeded. Application of voltage in excess of absolute maximum rating or use out of absolute maximum rated temperature environment may cause deterioration of characteristics.

- (1) Supply Voltage (VDD/VSS)
Indicates the maximum voltage that can be applied between the positive power supply terminal and negative power supply terminal without deterioration or destruction of characteristics of internal circuit.
- (2) Differential Input Voltage (V_{ID})
Indicates the maximum voltage that can be applied between non-inverting and inverting terminals without damaging the IC.
- (3) Input Common-mode Voltage Range (V_{ICM})
Indicates the maximum voltage that can be applied to the non-inverting and inverting terminals without deterioration or destruction of electrical characteristics. Input common-mode voltage range of the maximum ratings does not assure normal operation of IC. For normal operation, use the IC within the input common-mode voltage range characteristics.
- (4) Power dissipation (P_D)
Indicates the power that can be consumed by the IC when mounted on a specific board at the ambient temperature 25°C (normal temperature). As for package product, P_D is determined by the temperature that can be permitted by the IC in the package (maximum junction temperature) and the thermal resistance of the package.

2. Electrical characteristics

- (1) Input Offset Voltage (V_{IO})
Indicates the voltage difference between non-inverting terminal and inverting terminals. It can be translated into the input voltage difference required for setting the output voltage at 0 V.
- (2) Input Offset Voltage Drift (ΔV_{IO} / ΔT)
Denotes the ratio of the input offset voltage fluctuation to the ambient temperature fluctuation.
- (3) Input Offset Current (I_{IO})
Indicates the difference of input bias current between the non-inverting and inverting terminals.
- (4) Input Bias Current (I_B)
Indicates the current that flows into or out of the input terminal. It is defined by the average of input bias currents at the non-inverting and inverting terminals.
- (5) Supply Current (I_{DD})
Indicates the current that flows within the IC under specified no-load conditions.
- (6) Maximum Output Voltage (High) / Maximum Output Voltage (Low) (V_{OH}/V_{OL})
Indicates the voltage range of the output under specified load condition. It is typically divided into maximum output voltage High and low. Maximum output voltage high indicates the upper limit of output voltage. Maximum output voltage low indicates the lower limit.
- (7) Large Signal Voltage Gain (A_v)
Indicates the amplifying rate (gain) of output voltage against the voltage difference between non-inverting terminal and inverting terminal. It is normally the amplifying rate (gain) with reference to DC voltage.
 $A_v = (\text{Output voltage}) / (\text{Differential Input voltage})$
- (8) Input Common-mode Voltage Range (V_{ICM})
Indicates the input voltage range where IC normally operates.
- (9) Common-mode Rejection Ratio (CMRR)
Indicates the ratio of fluctuation of input offset voltage when the input common mode voltage is changed. It is normally the fluctuation of DC.
 $CMRR = (\text{Change of Input common-mode voltage}) / (\text{Input offset fluctuation})$
- (10) Power Supply Rejection Ratio (PSRR)
Indicates the ratio of fluctuation of input offset voltage when supply voltage is changed.
It is normally the fluctuation of DC.
 $PSRR = (\text{Change of power supply voltage}) / (\text{Input offset fluctuation})$
- (11) Output Source Current / Output Sink Current (I_{source} / I_{sink})
The maximum current that can be output from the IC under specific output conditions. The output source current indicates the current flowing out from the IC, and the output sink current indicates the current flowing into the IC.
- (12) Channel Separation (CS)
Indicates the fluctuation in the output voltage of the driven channel with reference to the change of output voltage of the channel which is not driven.
- (13) Slew Rate (SR)
Indicates the ratio of the change in output voltage with time when a step input signal is applied.
- (14) Gain Bandwidth (GBW)
The product of the open-loop voltage gain and the frequency at which the voltage gain decreases 6dB/octave.
- (15) Unity Gain Frequency (f_r)
Indicates a frequency where the voltage gain of operational amplifier is 1.
- (16) Phase Margin (θ)
Indicates the margin of phase from 180 degree phase lag at unity gain frequency.

- (17) Gain Margin (GM)
Indicates the difference between 0dB and the gain where operational amplifier has 180 degree phase delay.
- (18) Total Harmonic Distortion+Noise (THD+N)
Indicates the fluctuation of input offset voltage or that of output voltage with reference to the change of output voltage of driven channel.
- (19) Input Referred Noise Voltage (V_N)
Indicates a noise voltage generated inside the operational amplifier equivalent by ideal voltage source connected in series with input terminal.
- (20) Turn on Time from Shutdown (t_{ON})
Indicates the time from applying the voltage to shutdown terminal until the IC is active.
- (21) Turn on Voltage / Turn off Voltage (V_{SHDN_H} / V_{SHDN_L})
The IC is active if the shutdown terminal is applied more than Turn On Voltage (V_{SHDN_H}).
The IC is shutdown if the shutdown terminal is applied less than Turn Off Voltage (V_{SHDN_L}).

Typical Performance Curves

○ LMR981G, LMR931G

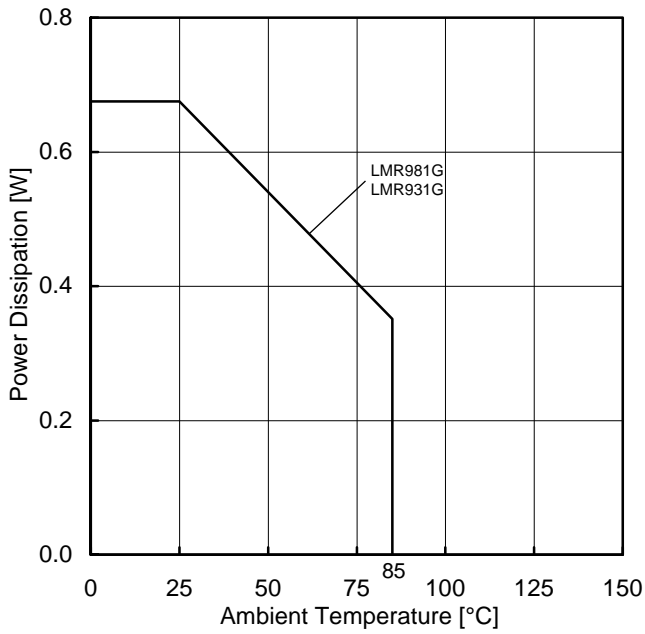

Figure 2.
Power Dissipation vs Ambient Temperature
(Derating Curve)

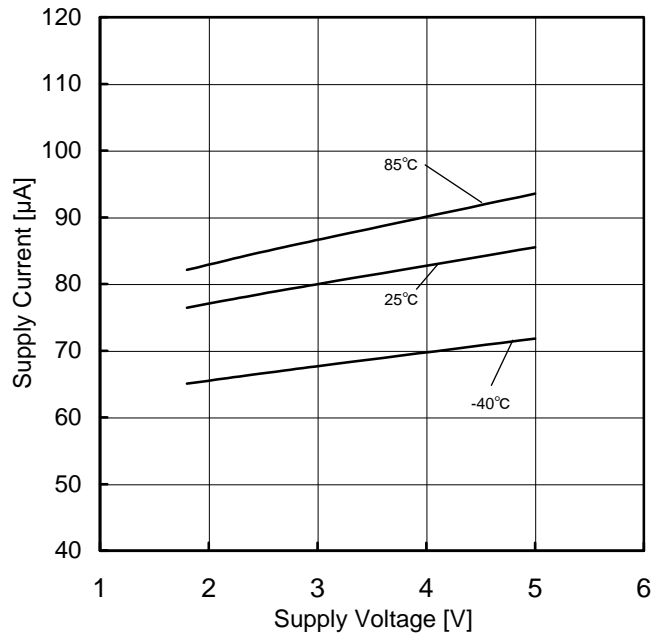

Figure 3.
Supply Current vs Supply Voltage

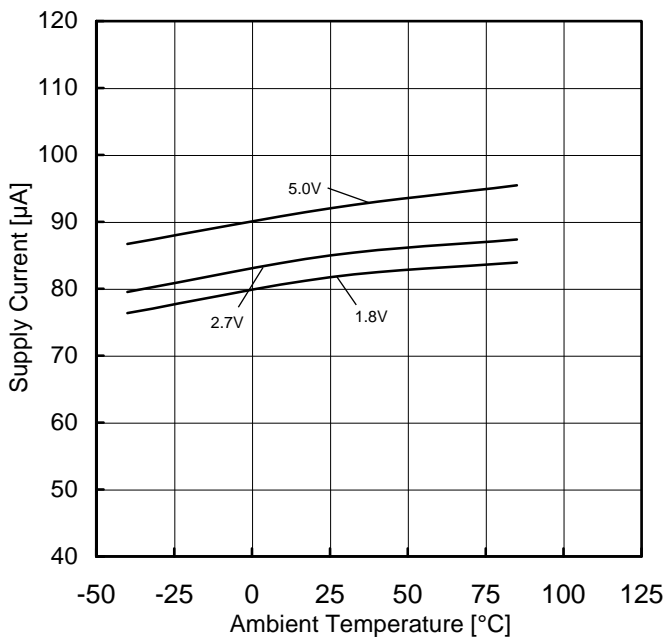

Figure 4.
Supply Current vs Ambient Temperature

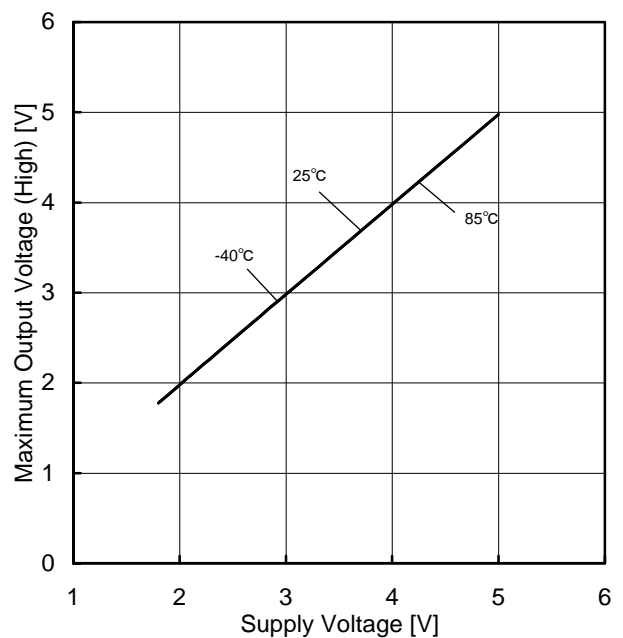

Figure 5.
Maximum Output Voltage (High) vs Supply Voltage
($R_L=2k\Omega$)

(Note) The data above is measurement value of typical sample, it is not guaranteed.

Typical Performance Curves (Reference data) – continued

○ LMR981G, LMR931G

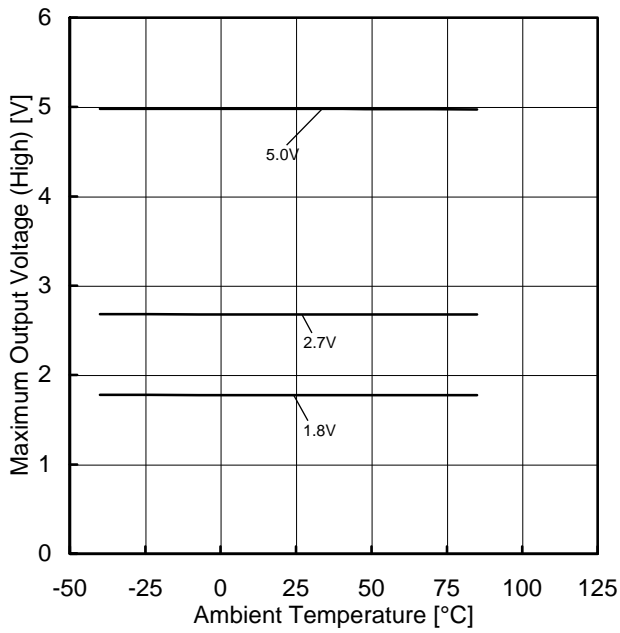

Figure 6.
Maximum Output Voltage (High) vs Ambient Temperature
($R_L=2k\Omega$)

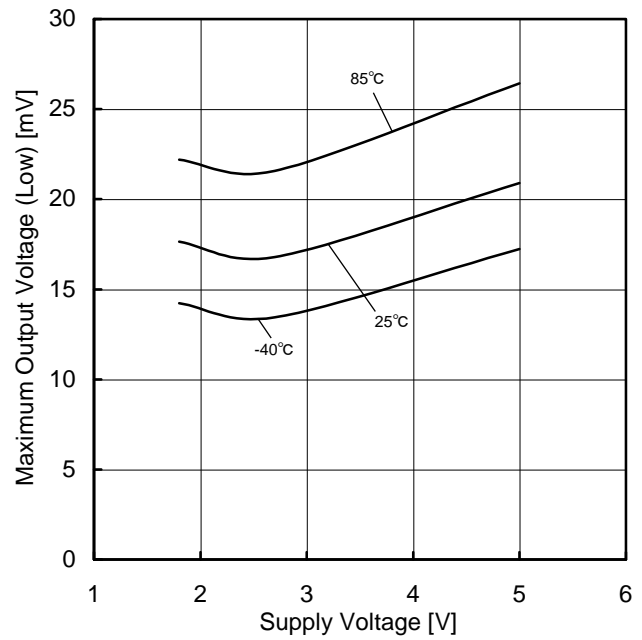

Figure 7.
Maximum Output Voltage (Low) vs Supply Voltage
($R_L=2k\Omega$)

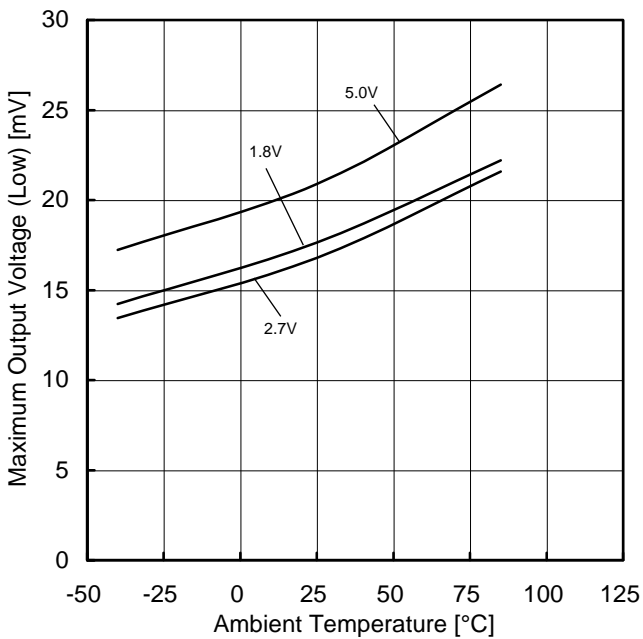

Figure 8.
Maximum Output Voltage (Low) vs Ambient Temperature
($R_L=2k\Omega$)

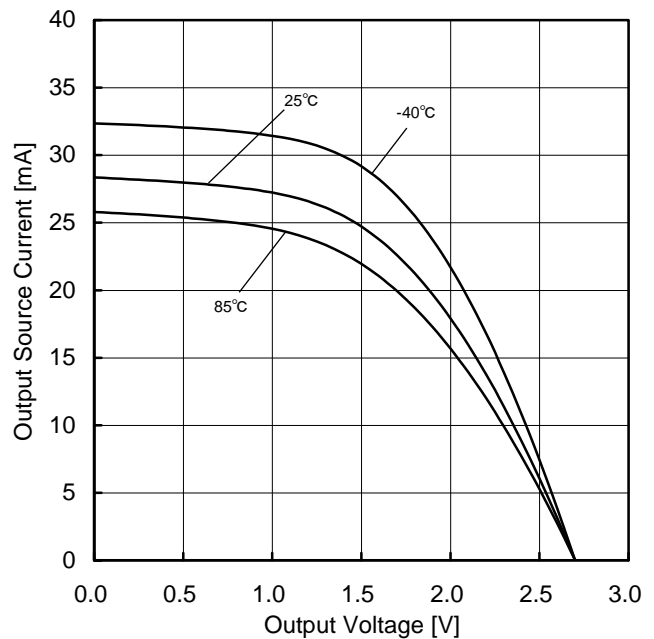

Figure 9.
Output Source Current vs Output Voltage
($V_{DD}=2.7V$)

(Note)The data above is measurement value of typical sample, it is not guaranteed.

Typical Performance Curves (Reference data) – continued

○ LMR981G, LMR931G

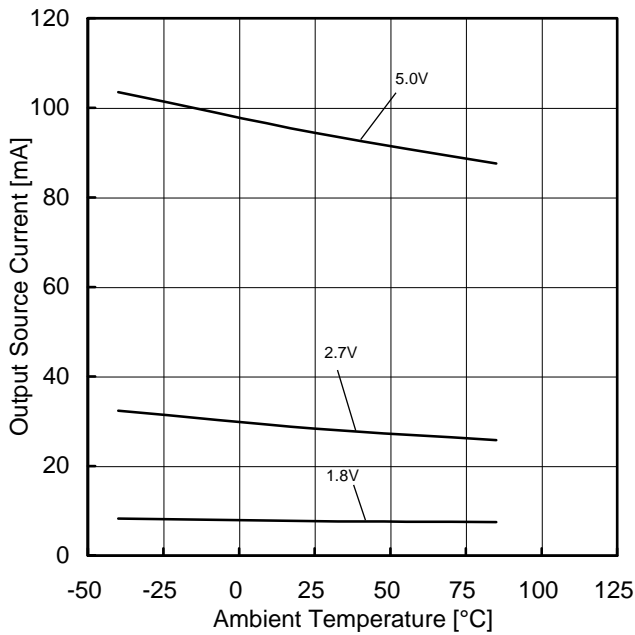

Figure 10.
Output Source Current vs Ambient Temperature
(OUT=VSS)

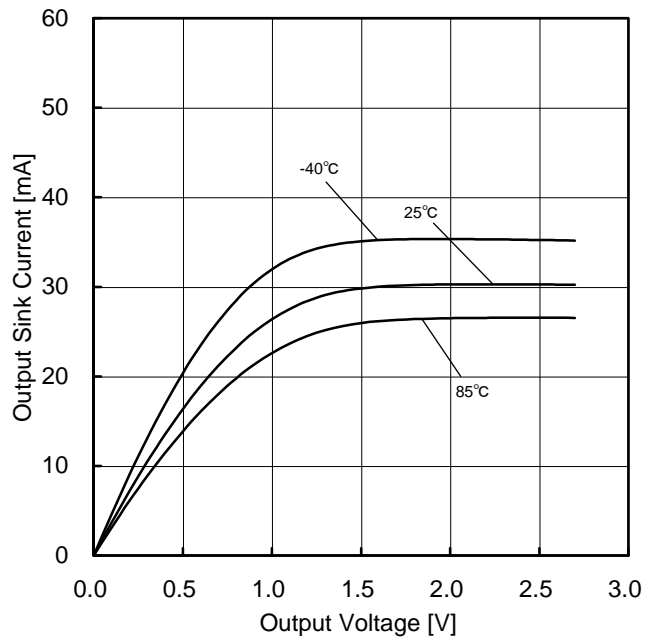

Figure 11.
Output Sink Current vs Output Voltage
(VDD=2.7V)

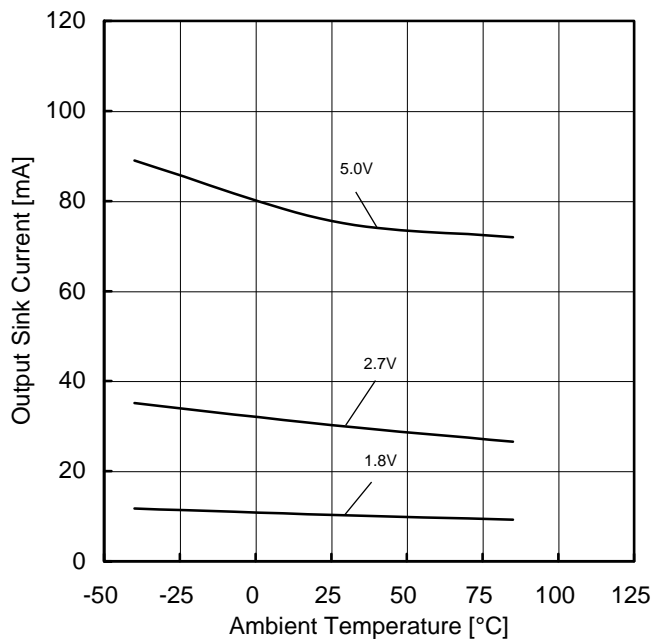

Figure 12.
Output Sink Current vs Ambient Temperature
(OUT=VDD)

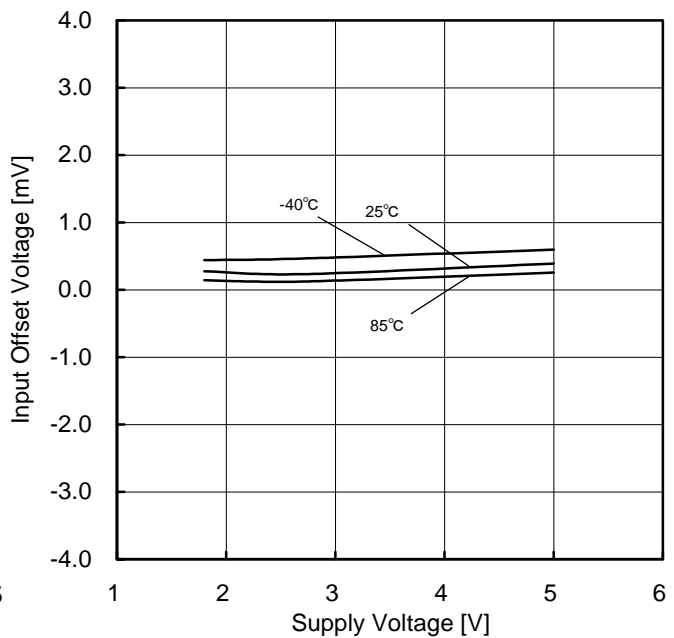

Figure 13.
Input Offset Voltage vs Supply Voltage

(Note)The data above is measurement value of typical sample, it is not guaranteed.

Typical Performance Curves (Reference data) - continued

○ LMR981G, LMR931G

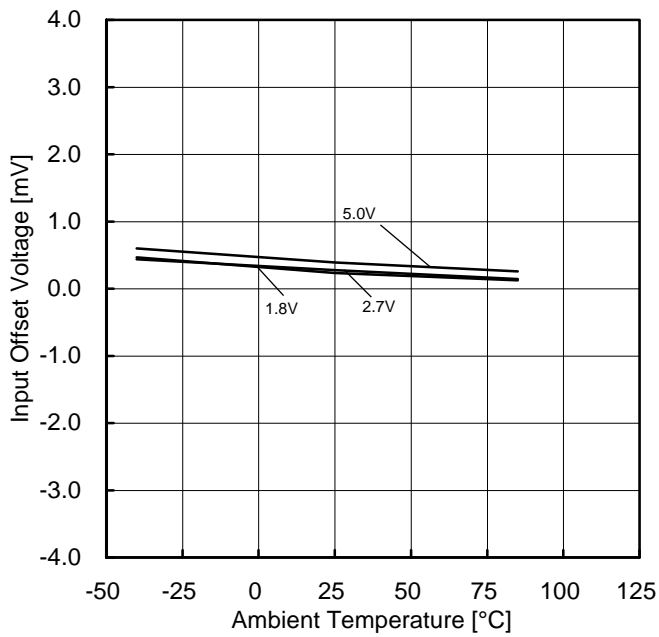

Figure 14.
Input Offset Voltage vs Ambient Temperature

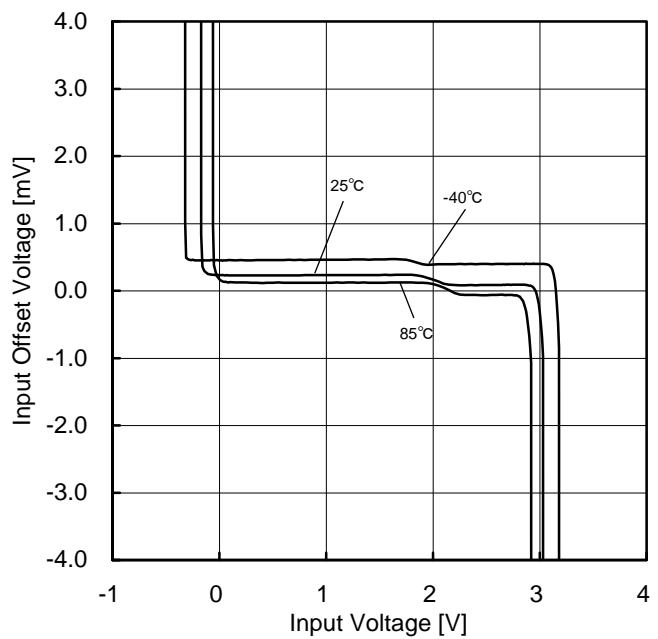

Figure 15.
Input Offset Voltage vs Input Voltage
(VDD=2.7V)

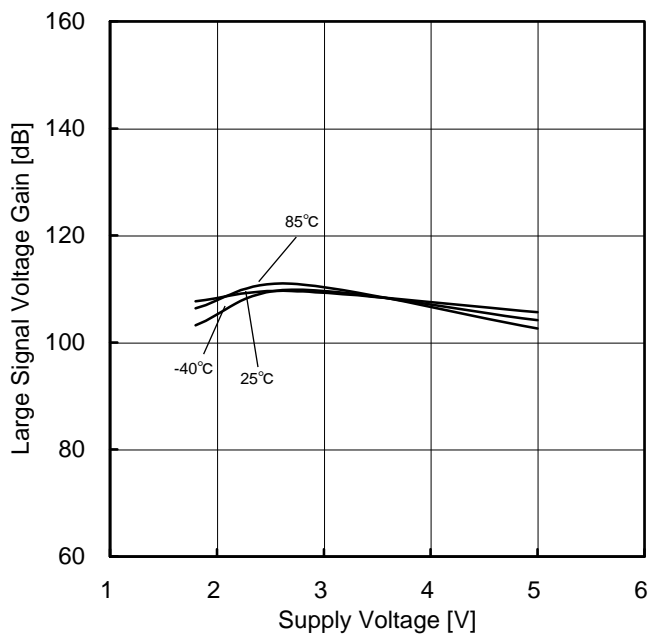

Figure 16.
Large Signal Voltage Gain vs Supply Voltage

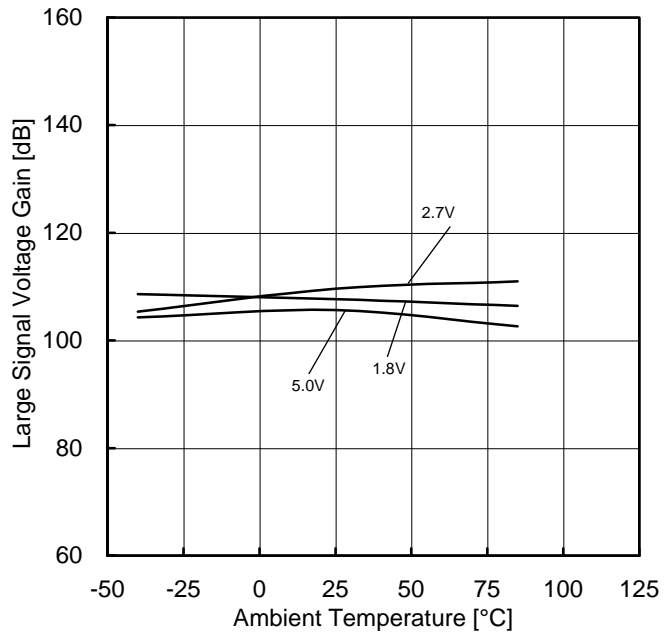

Figure 17.
Large Signal Voltage Gain vs Ambient Temperature

(Note)The data above is measurement value of typical sample, it is not guaranteed.

Typical Performance Curves (Reference data) - continued

○ LMR981G, LMR931G

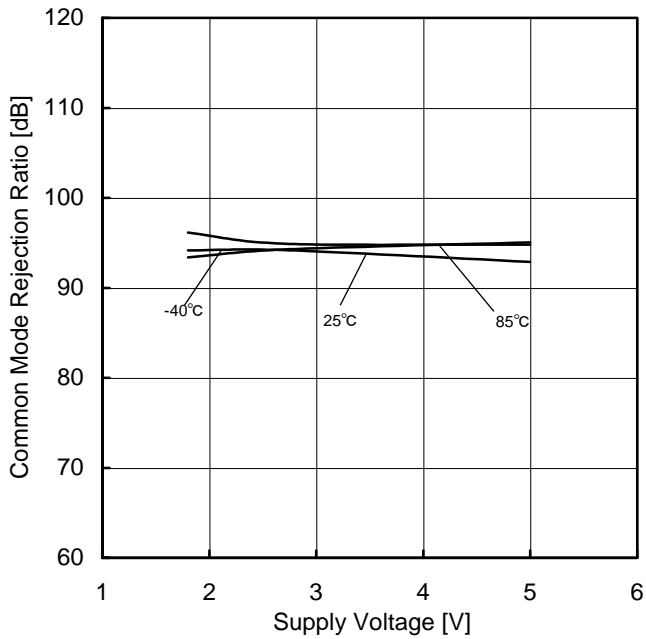

Figure 18.
Common Mode Rejection Ratio vs Supply Voltage (VDD=2.7V)

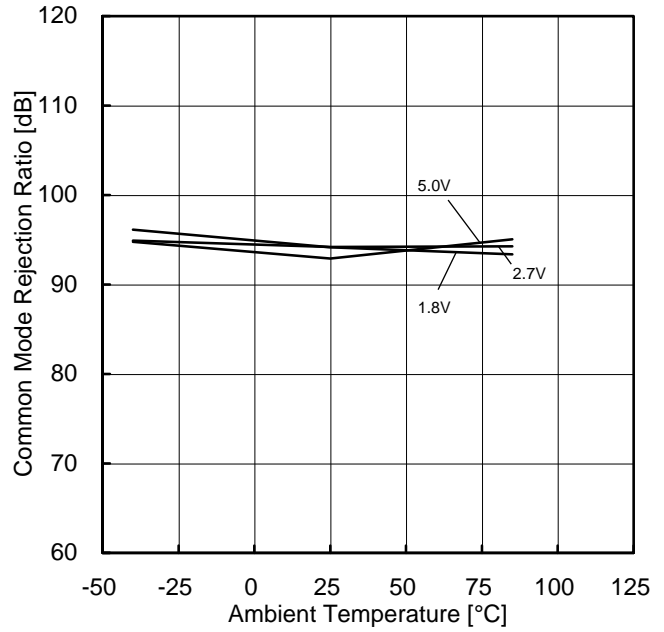

Figure 19.
Common Mode Rejection Ratio vs Ambient Temperature

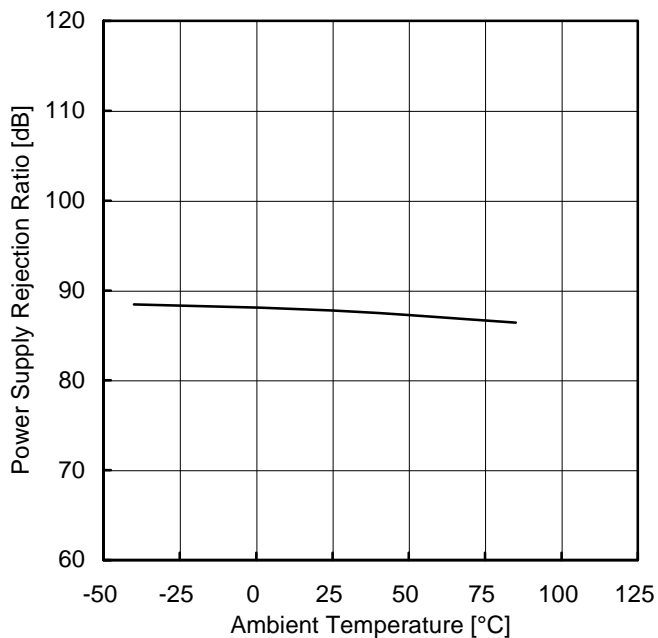

Figure 20.
Power Supply Rejection Ratio vs Ambient Temperature (VDD=1.8V to 5.0V)

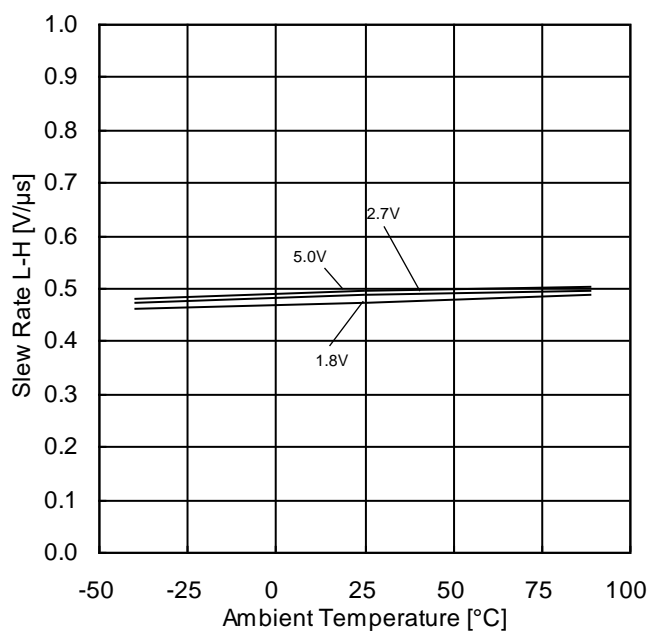

Figure 21.
Slew Rate L-H – Ambient Temperature

(Note) The data above is measurement value of typical sample, it is not guaranteed.

Typical Performance Curves (Reference data) - continued

○ LMR981G, LMR931G

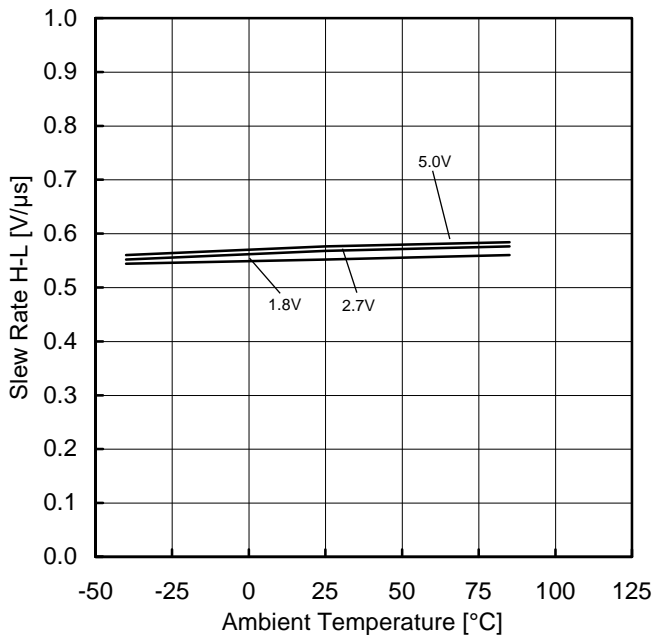

Figure 22.
Slew Rate H-L vs Ambient Temperature

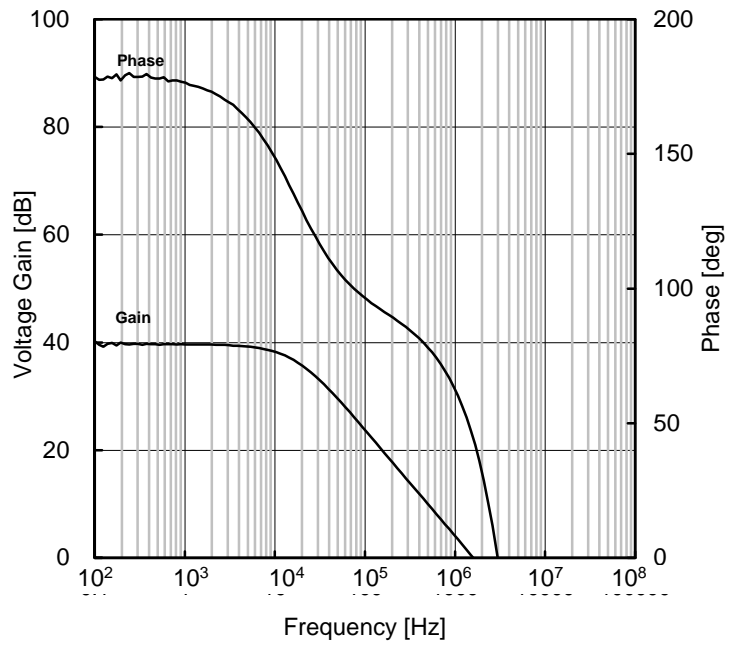

Figure 23.
Voltage Gain, Phase vs Frequency

(Note)The data above is measurement value of typical sample, it is not guaranteed.

Typical Performance Curves (Reference data) - continued

○ LMR981G

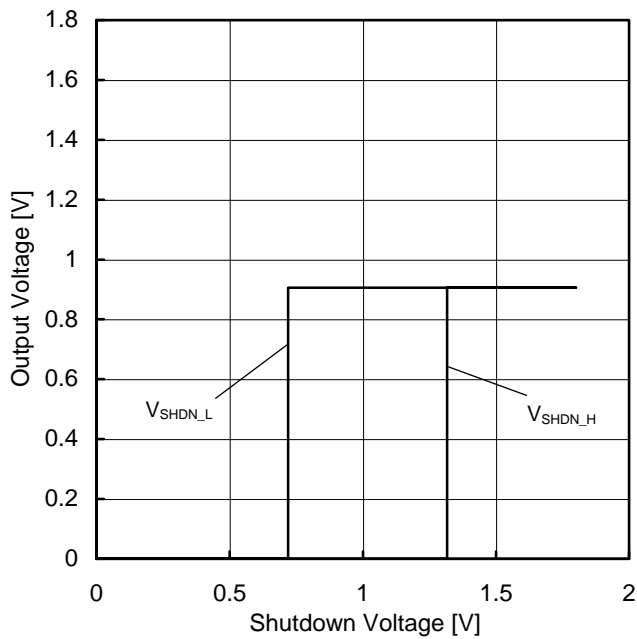

Figure 24.
Turn On/Off Voltage – Supply Voltage
(VDD=1.8V, Av=0dB, IN=0.9V)

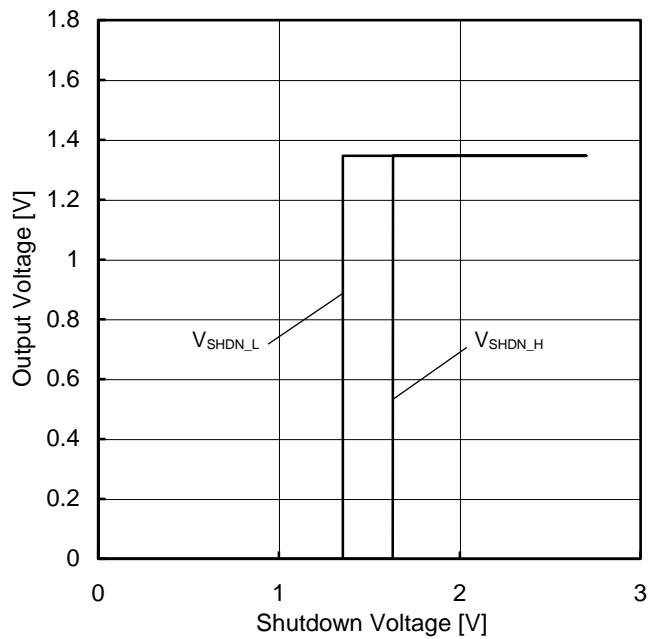

Figure 25.
Turn On/Off Voltage – Supply Voltage
(VDD=2.7V, Av=0dB, IN=1.35V)

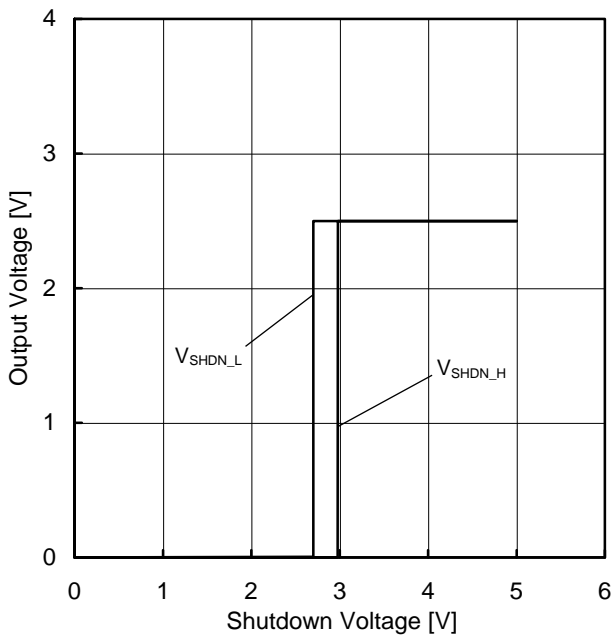

Figure 26.
Turn On/Off Voltage vs Supply Voltage
(VDD=5V, Av=0dB, IN=2.5V)

(Note) The data above is measurement value of typical sample, it is not guaranteed.

Typical Performance Curves
 ○ LMR982FVM, LMR932xxx

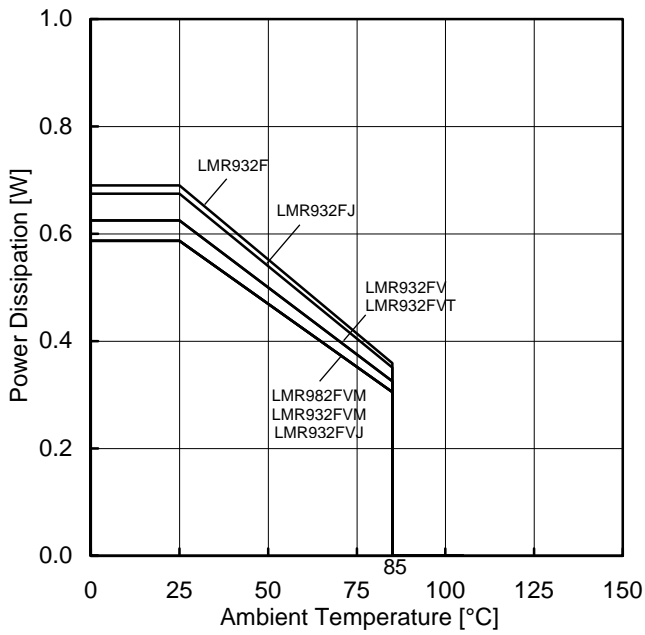

Figure 27.
 Power Dissipation vs Ambient Temperature
 (Derating Curve)

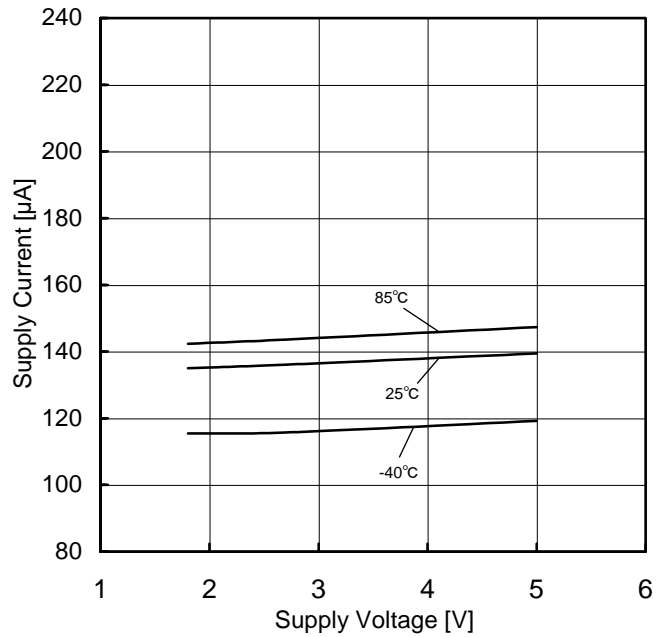

Figure 28.
 Supply Current vs Supply Voltage

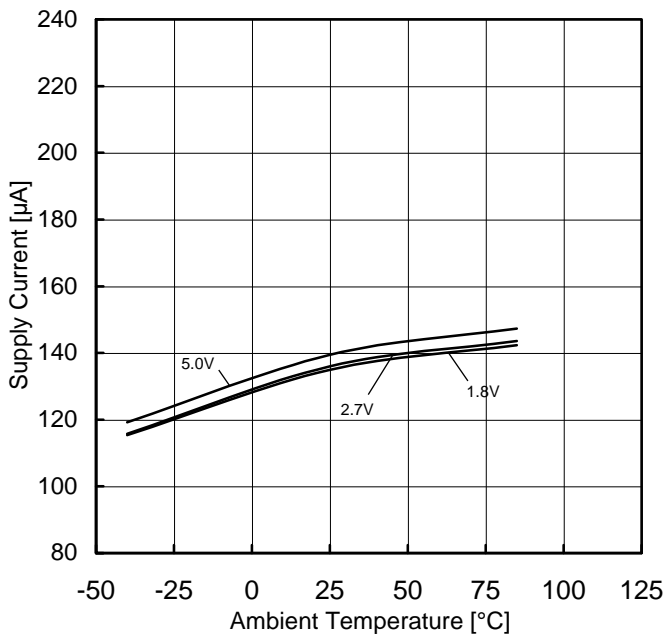

Figure 29.
 Supply Current vs Ambient Temperature

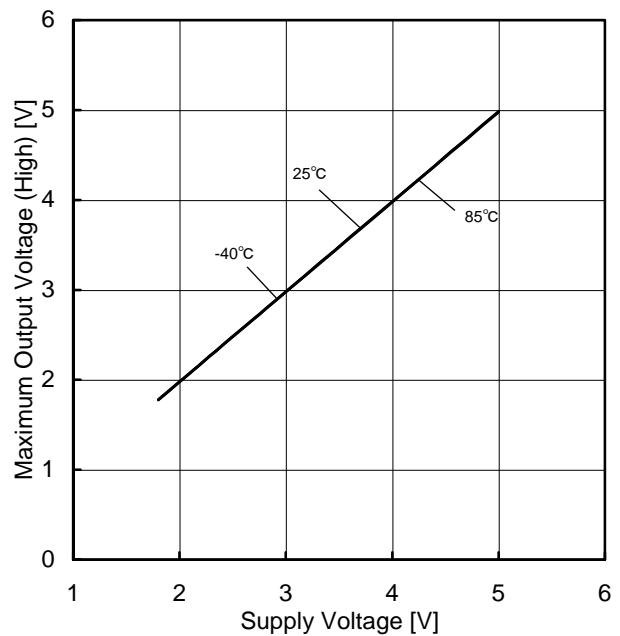

Figure 30.
 Maximum Output Voltage (High) vs Supply Voltage
 (RL=2kΩ)

(Note) The data above is measurement value of typical sample, it is not guaranteed.

Typical Performance Curves (Reference data) – continued

○ LMR982FVM, LMR932xxx

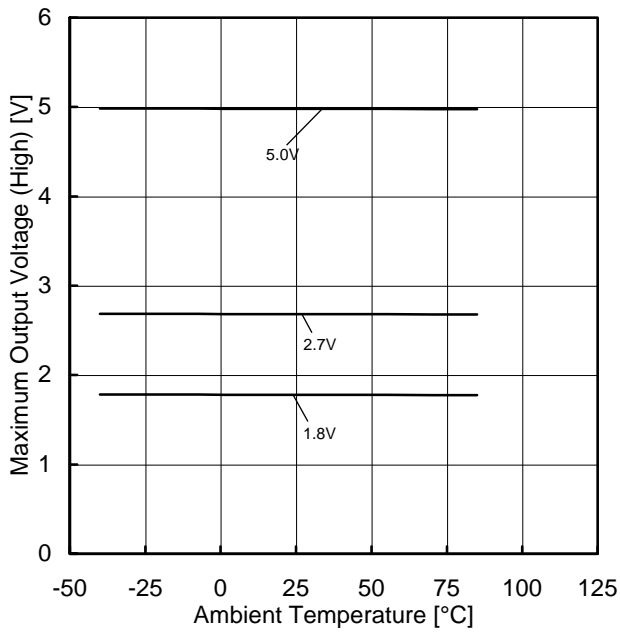

Figure 31.
Maximum Output Voltage (High) vs Ambient Temperature
($R_L=2k\Omega$)

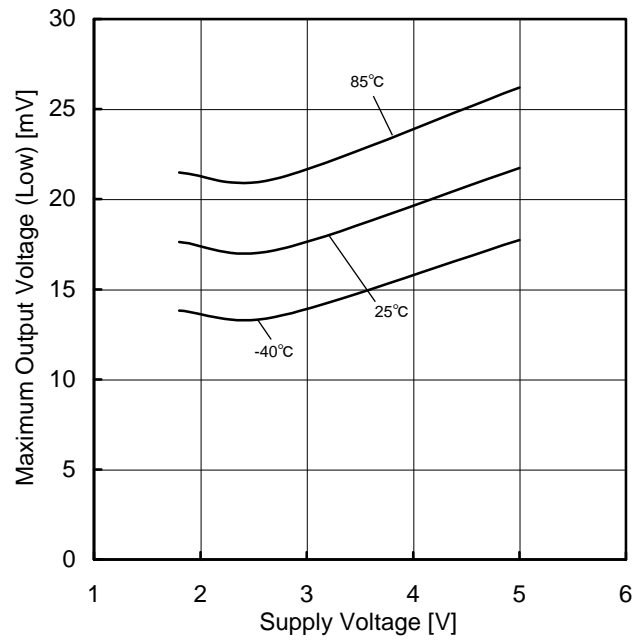

Figure 32.
Maximum Output Voltage (Low) vs Supply Voltage
($R_L=2k\Omega$)

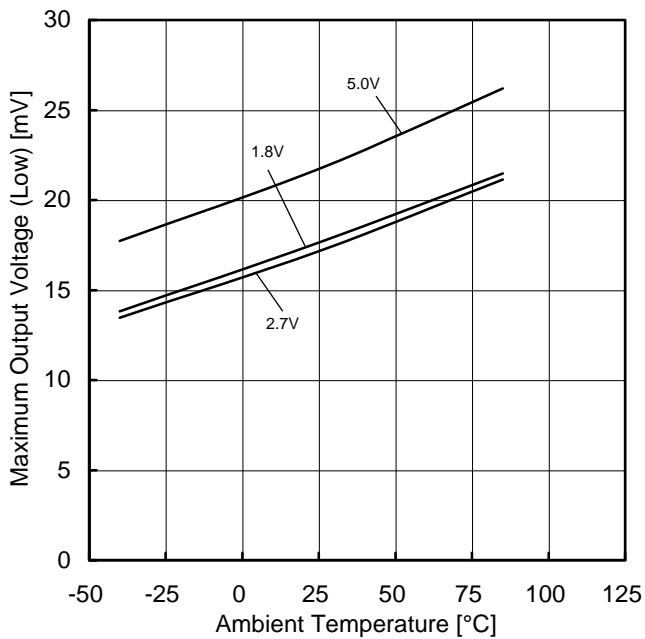

Figure 33.
Maximum Output Voltage (Low) vs Ambient Temperature
($R_L=2k\Omega$)

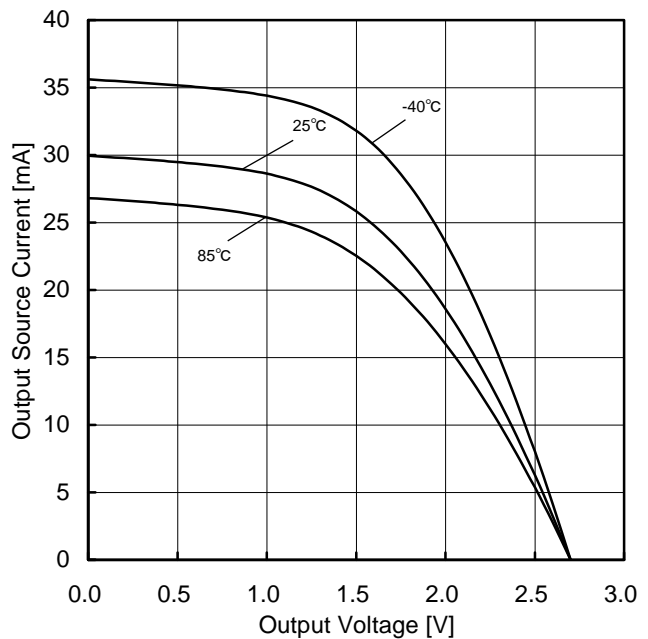

Figure 34.
Output Source Current vs Output Voltage
($V_{DD}=2.7V$)

(Note)The data above is measurement value of typical sample, it is not guaranteed.

Typical Performance Curves (Reference data) – continued

○ LMR982FVM, LMR932xxx

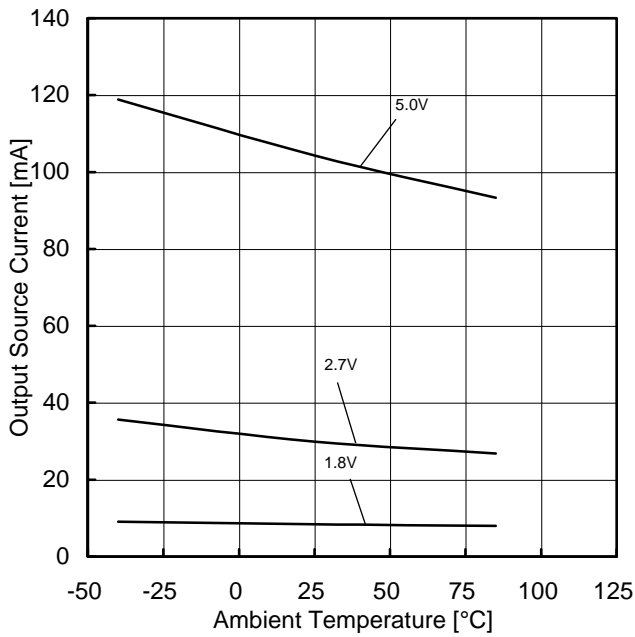

Figure 35.
Output Source Current vs Ambient Temperature
(OUT=VSS)

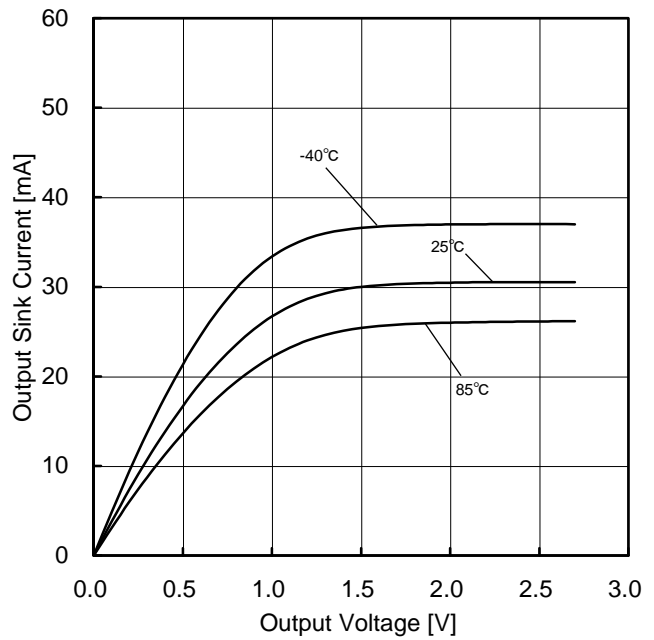

Figure 36.
Output Sink Current vs Output Voltage
(VDD=2.7V)

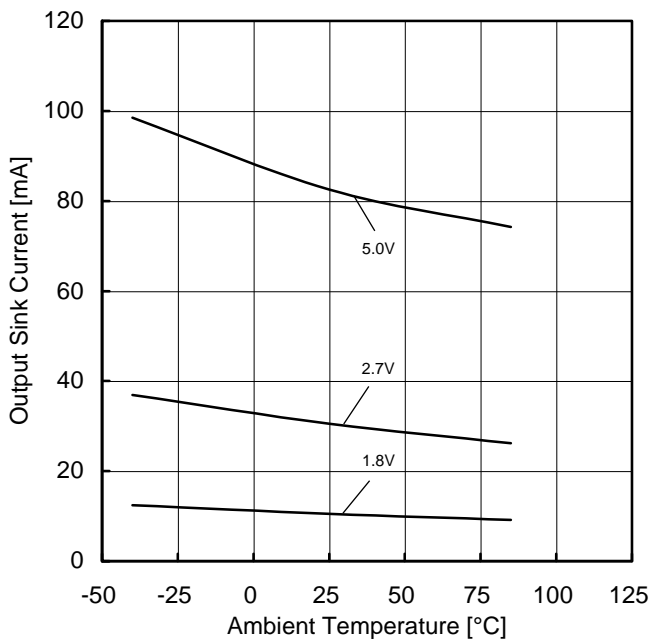

Figure 37.
Output Sink Current vs Ambient Temperature
(OUT=VDD)

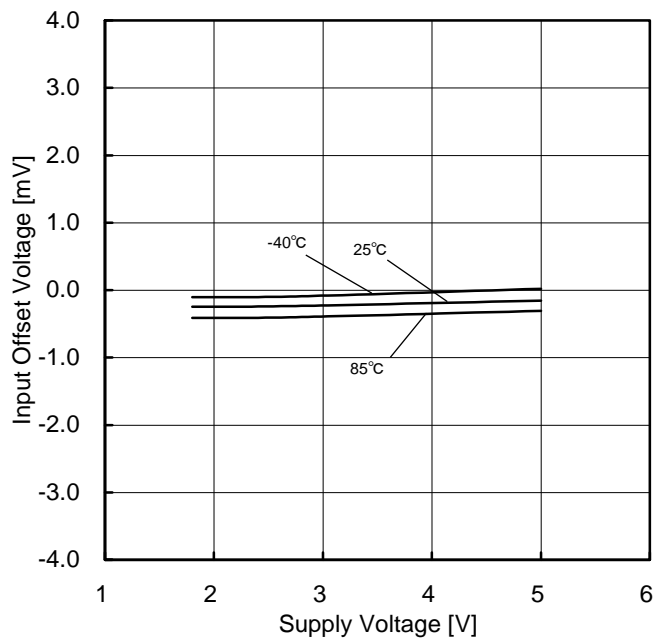

Figure 38.
Input Offset Voltage vs Supply Voltage

(Note)The data above is measurement value of typical sample, it is not guaranteed.

Typical Performance Curves (Reference data) - continued

○ LMR982FVM, LMR932xxx

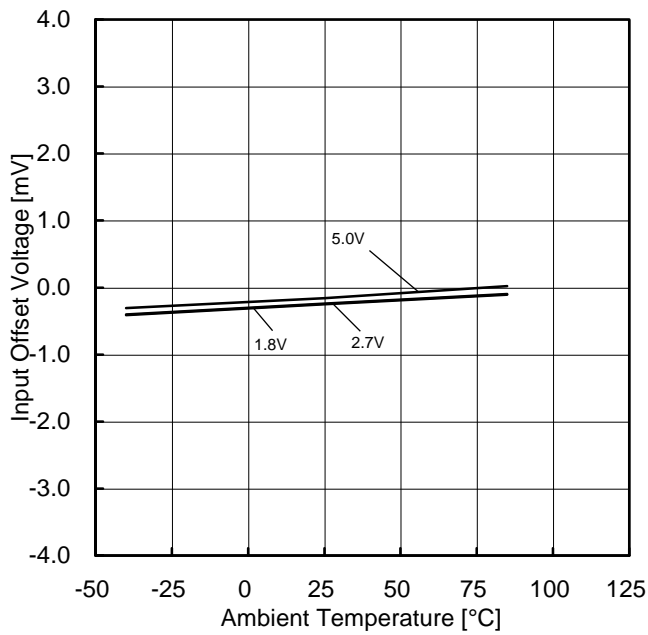

Figure 39.
Input Offset Voltage vs Ambient Temperature

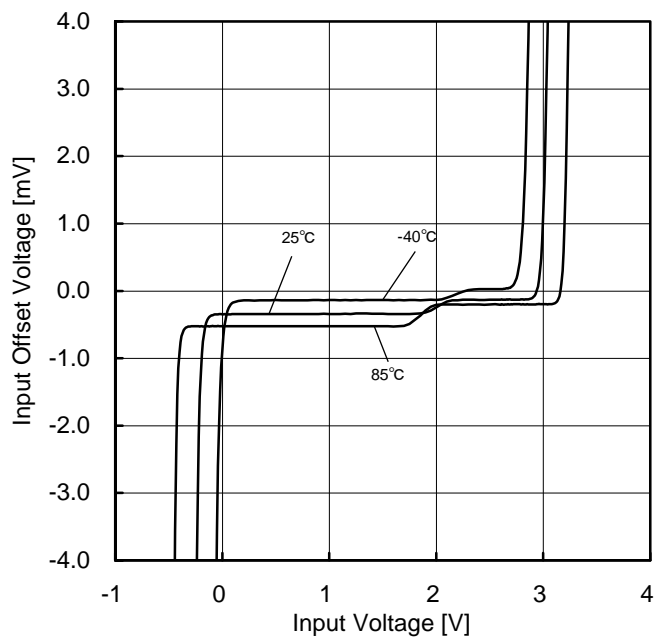

Figure 40.
Input Offset Voltage vs Input Voltage
(VDD=2.7V)

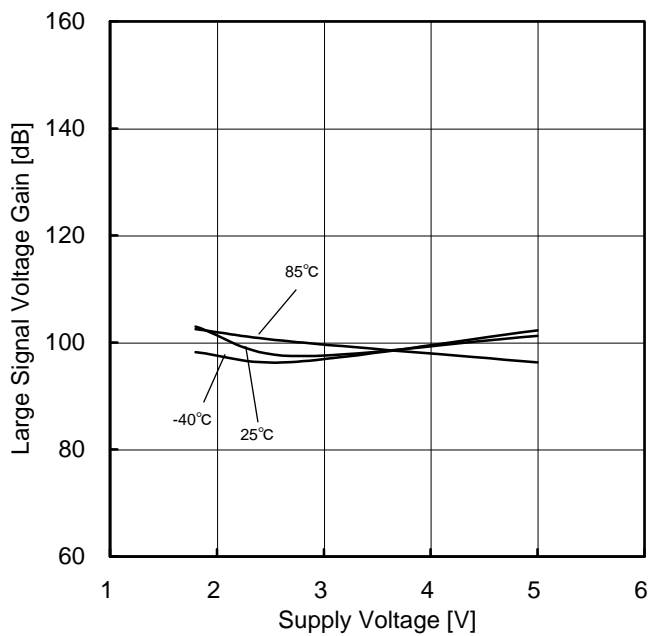

Figure 41.
Large Signal Voltage Gain vs Supply Voltage

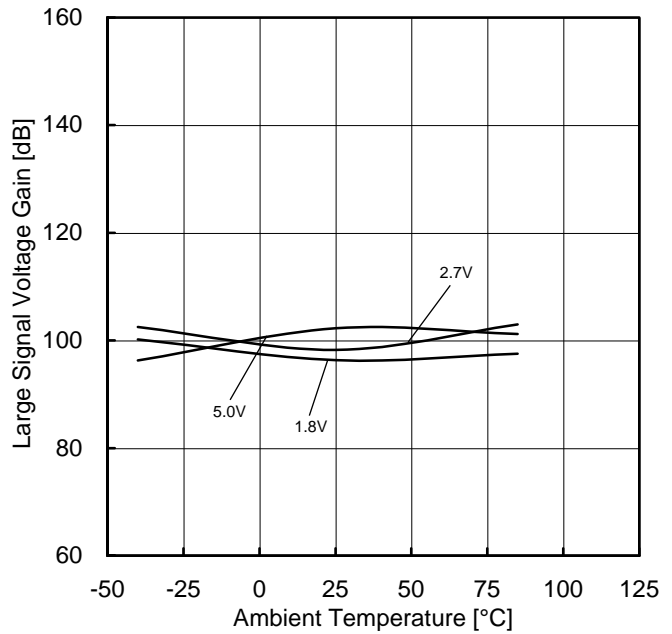

Figure 42.
Large Signal Voltage Gain vs Ambient Temperature

(Note)The data above is measurement value of typical sample, it is not guaranteed.

Typical Performance Curves (Reference data) - continued

○ LMR982FVM, LMR932xxx

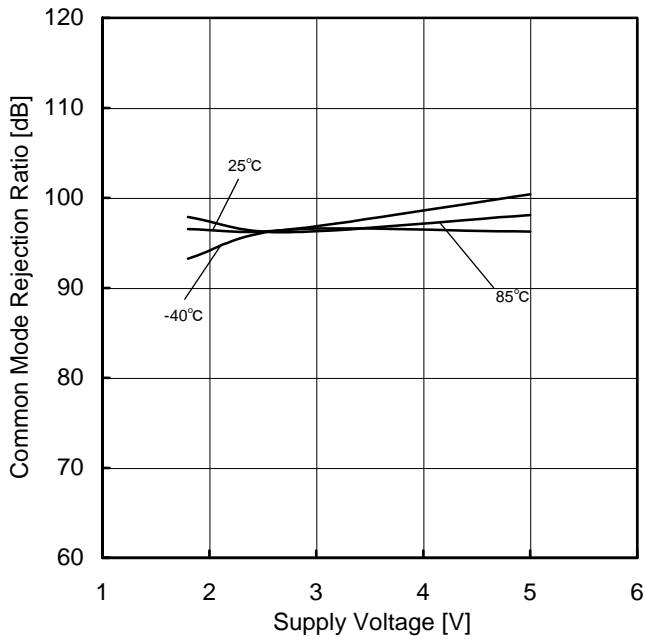

Figure 43.
Common Mode Rejection Ratio vs Supply Voltage (VDD=2.7V)

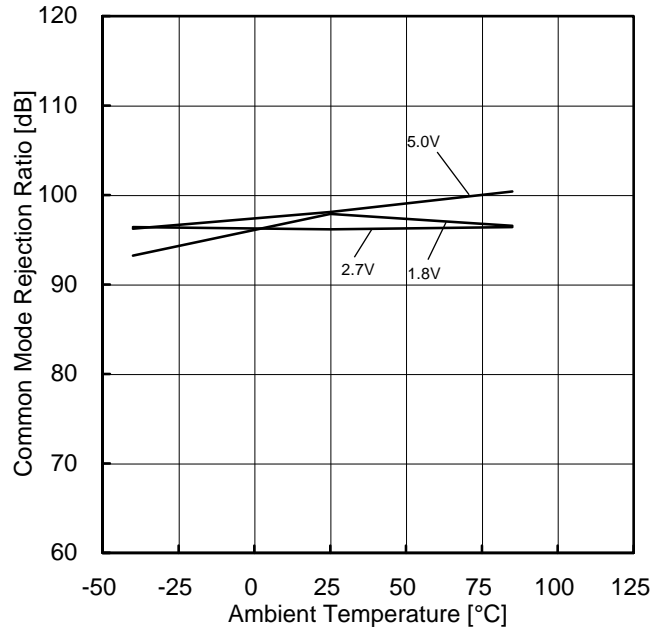

Figure 44.
Common Mode Rejection Ratio vs Ambient Temperature

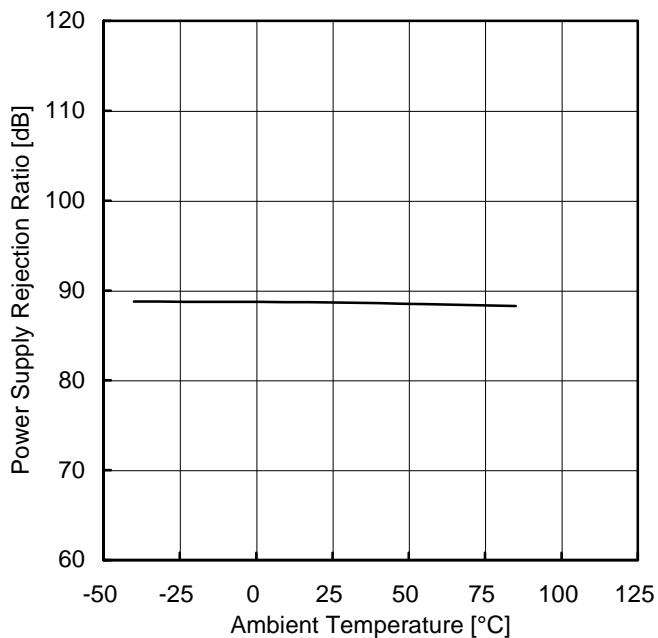

Figure 45.
Power Supply Rejection Ratio vs Ambient Temperature (VDD=1.8V to 5.0V)

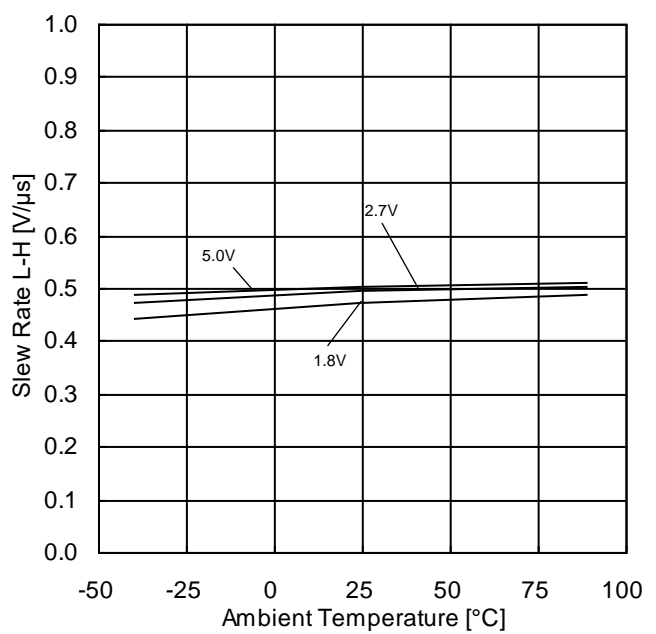

Figure 46.
Slew Rate L-H – Ambient Temperature

(Note) The data above is measurement value of typical sample, it is not guaranteed.

Typical Performance Curves (Reference data) - continued

○ LMR982FVM, LMR932xxx

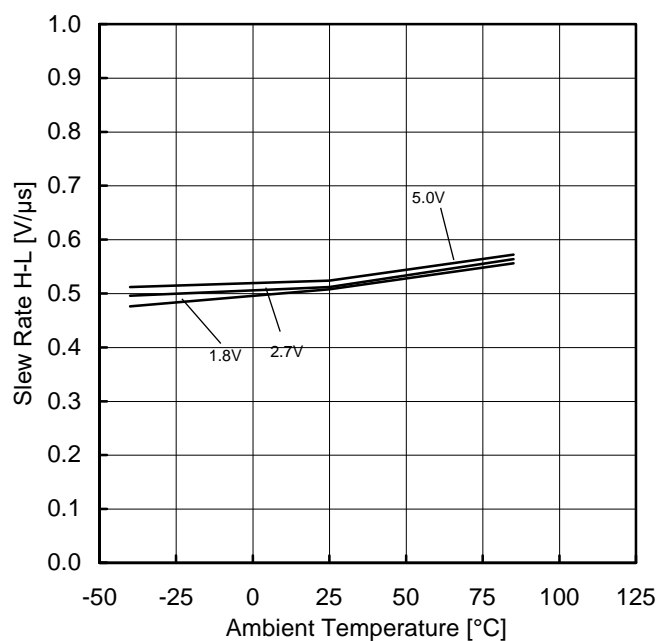

Figure 47.
Slew Rate H-L vs Ambient Temperature

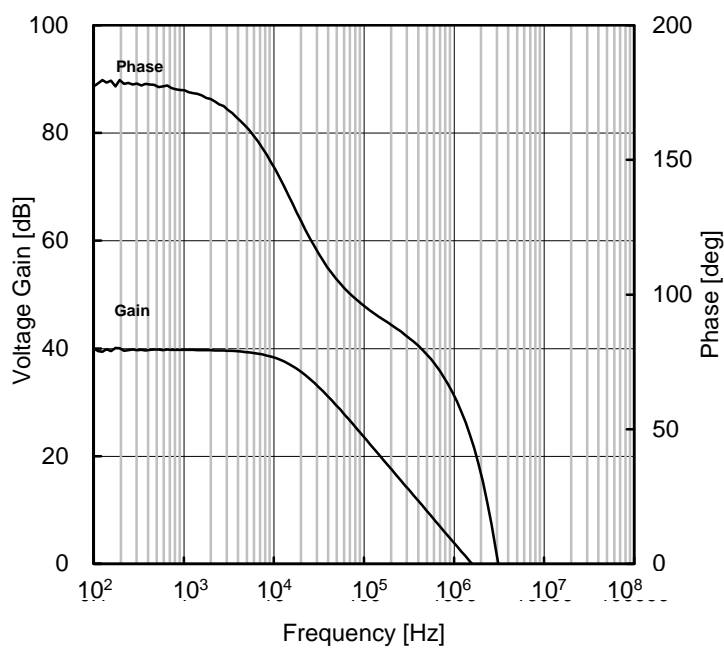

Figure 48.
Voltage Gain, Phase vs Frequency

(Note)The data above is measurement value of typical sample, it is not guaranteed.

Typical Performance Curves (Reference data) - continued

○ LMR982FVM

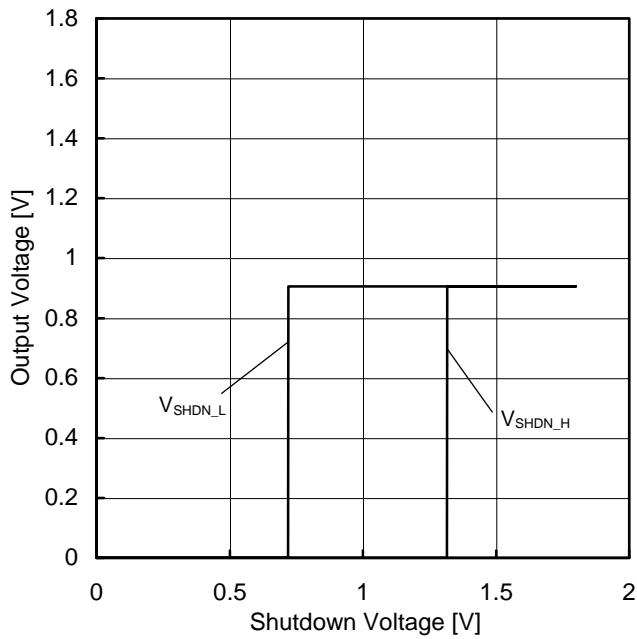

Figure 49.
Turn On/Off Voltage – Supply Voltage
(VDD=1.8V, Av=0dB, IN=0.9V)

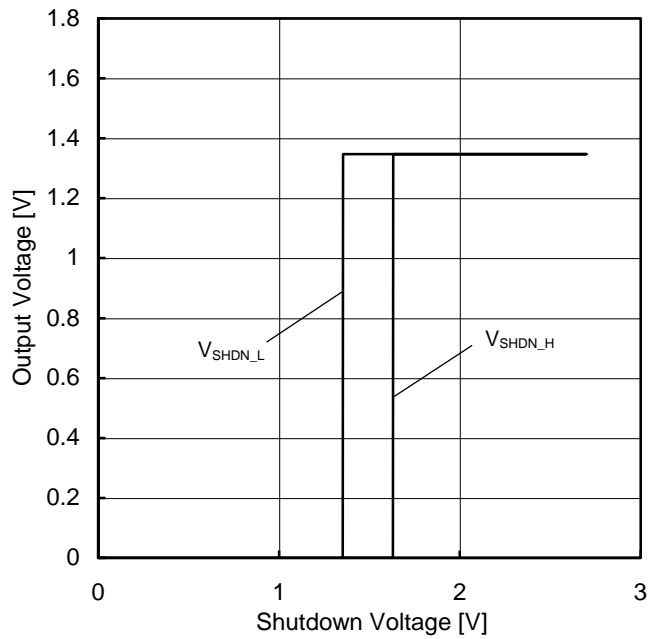

Figure 50.
Turn On/Off Voltage – Supply Voltage
(VDD=2.7V, Av=0dB, IN=1.35V)

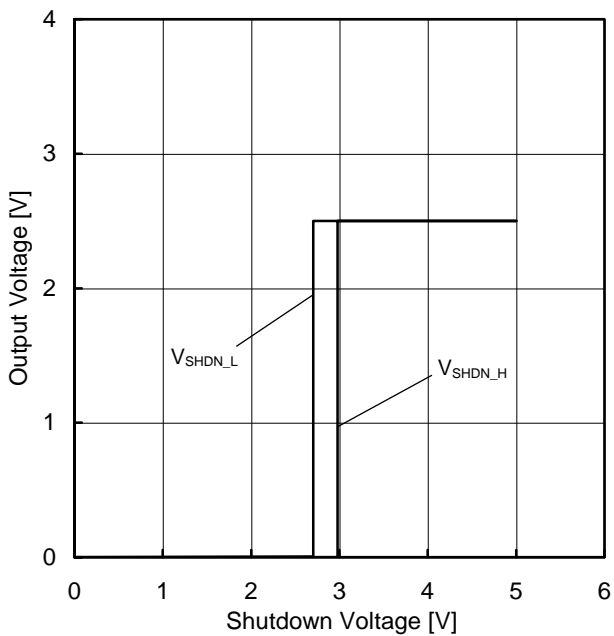

Figure 51.
Turn On/Off Voltage vs Supply Voltage
(VDD=5V, Av=0dB, IN=2.5V)

(Note) The data above is measurement value of typical sample, it is not guaranteed.

Typical Performance Curves

○ LMR934xxx

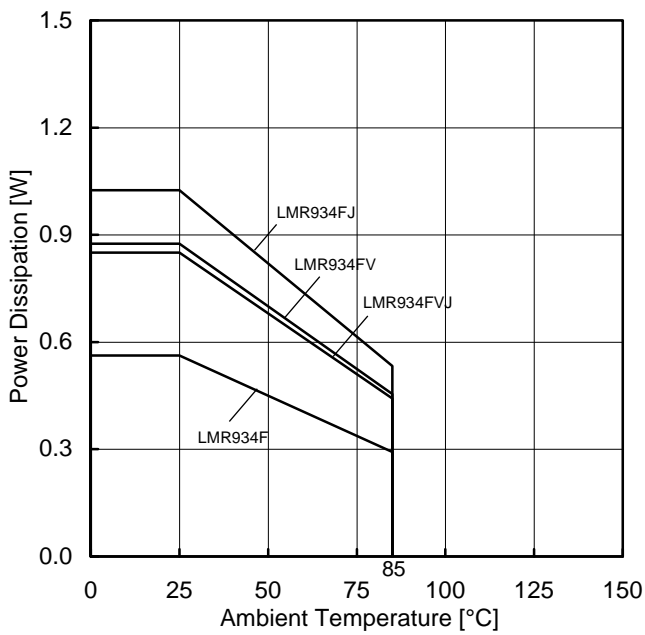

Figure 52.
Power Dissipation vs Ambient Temperature
(Derating Curve)

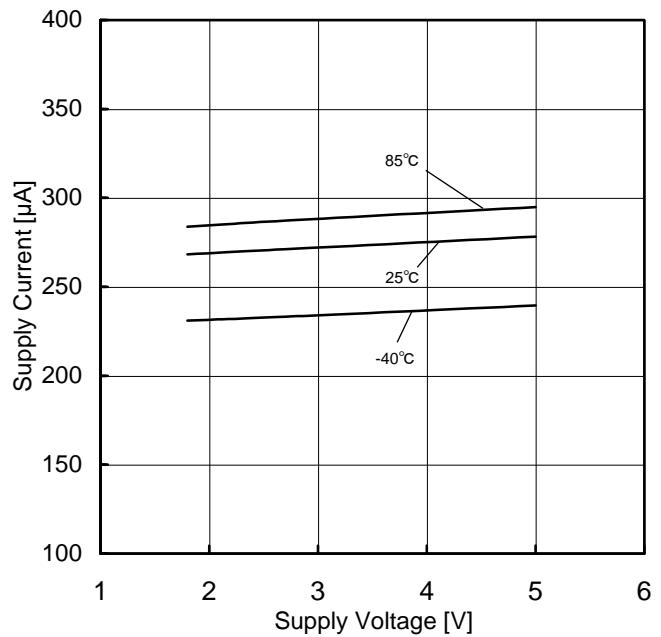

Figure 53.
Supply Current vs Supply Voltage

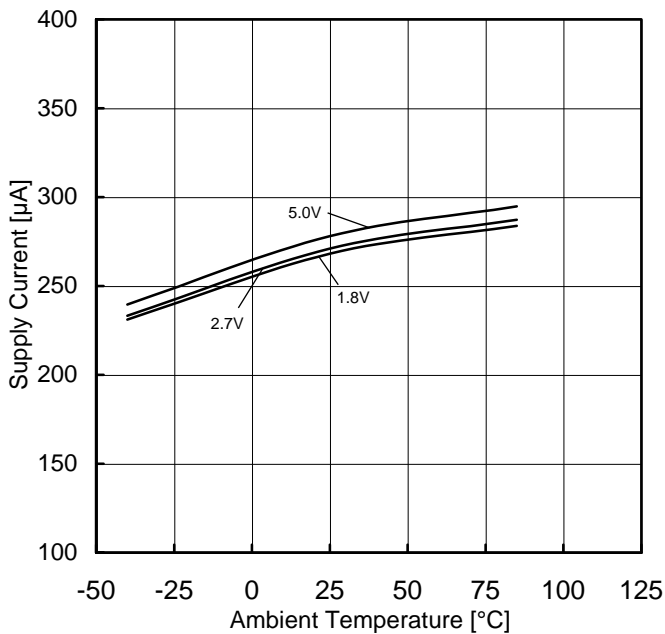

Figure 54.
Supply Current vs Ambient Temperature

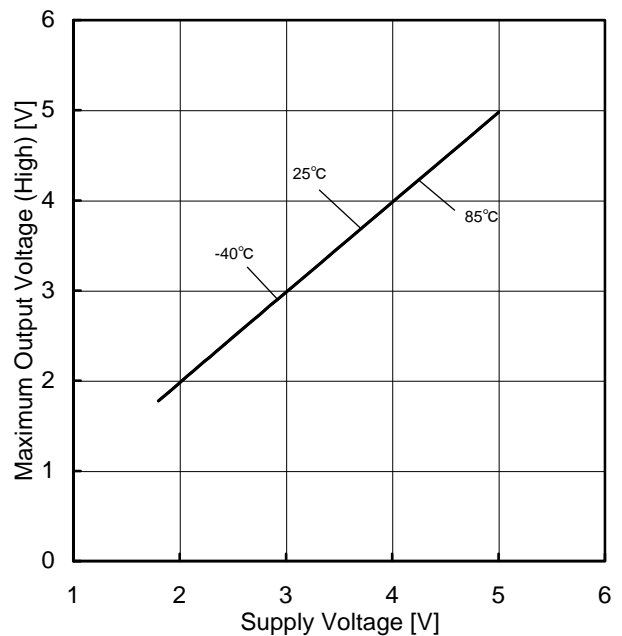

Figure 55.
Maximum Output Voltage (High) vs Supply Voltage
($R_L=2k\Omega$)

(Note) The data above is measurement value of typical sample, it is not guaranteed.

Typical Performance Curves (Reference data) – continued

○ LMR934xxx

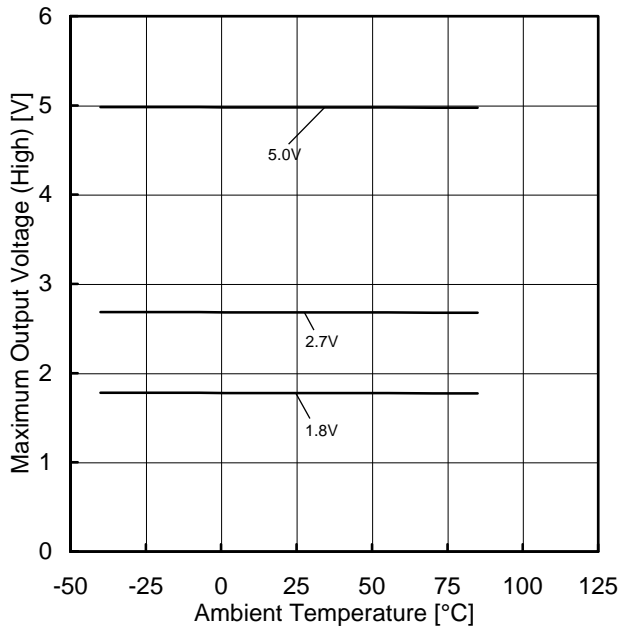

Figure 56.
Maximum Output Voltage (High) vs Ambient Temperature
($R_L=2k\Omega$)

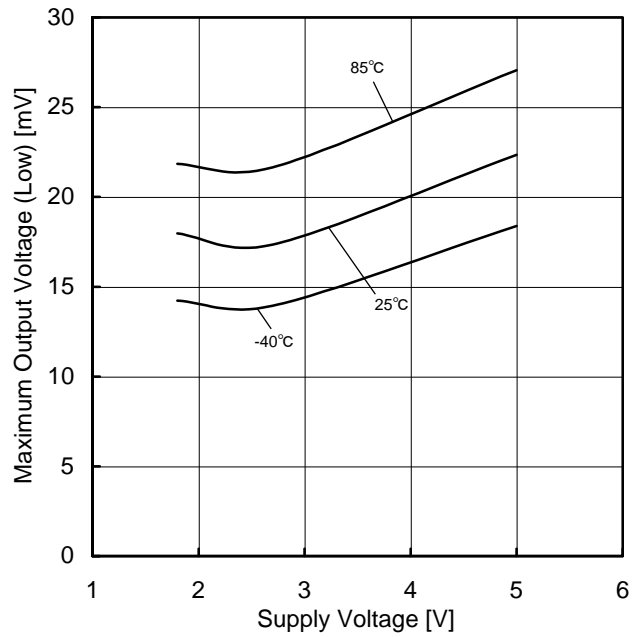

Figure 57.
Maximum Output Voltage (Low) vs Supply Voltage
($R_L=2k\Omega$)

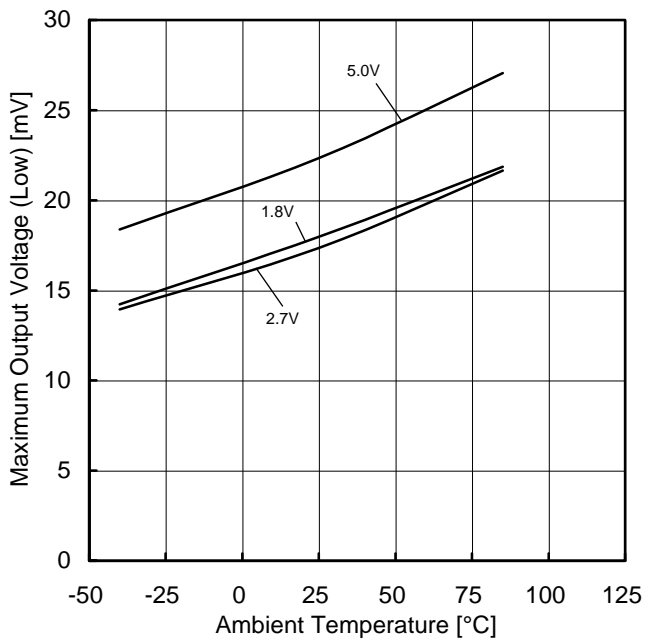

Figure 58.
Maximum Output Voltage (Low) vs Ambient Temperature
($R_L=2k\Omega$)

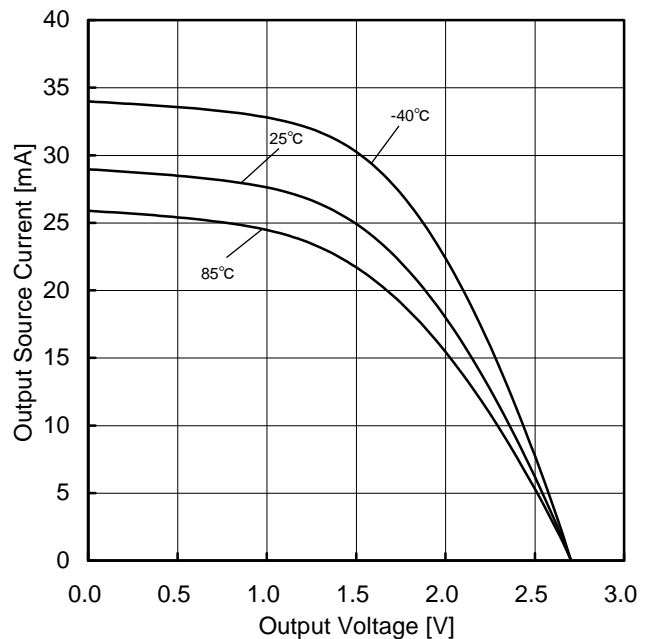

Figure 59.
Output Source Current vs Output Voltage
($V_{DD}=2.7V$)

(Note)The data above is measurement value of typical sample, it is not guaranteed.

Typical Performance Curves (Reference data) – continued

○ LMR934xxx

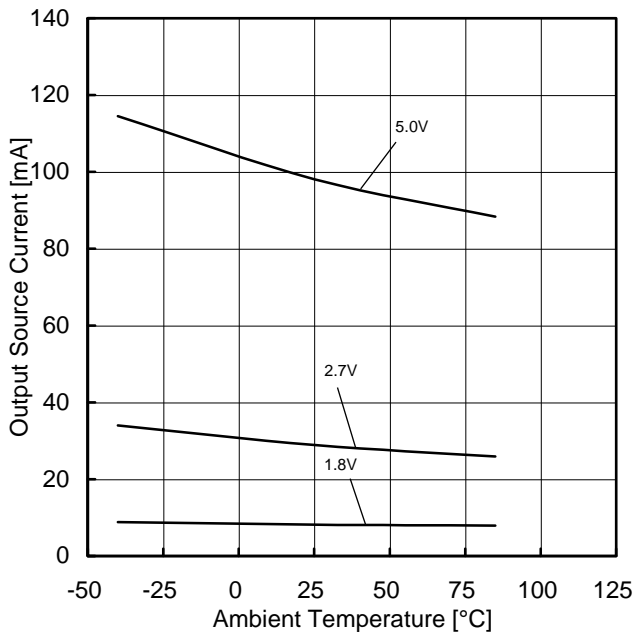

Figure 60.
Output Source Current vs Ambient Temperature
(OUT=VSS)

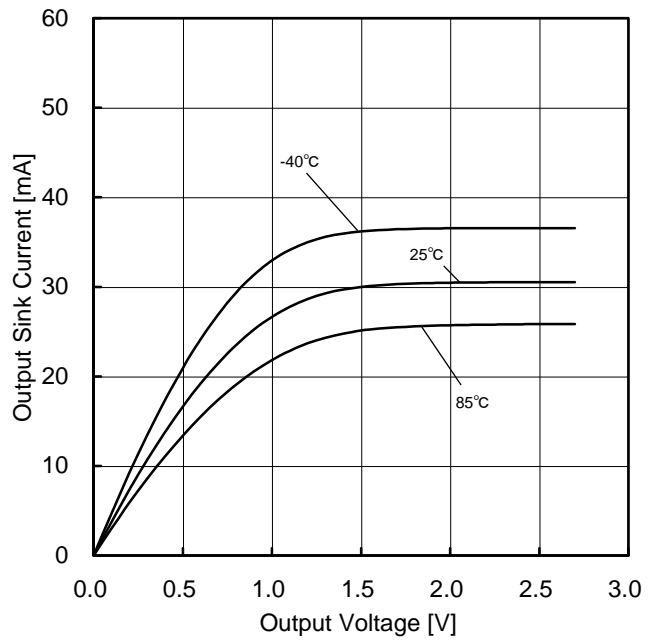

Figure 61.
Output Sink Current vs Output Voltage
(VDD=2.7V)

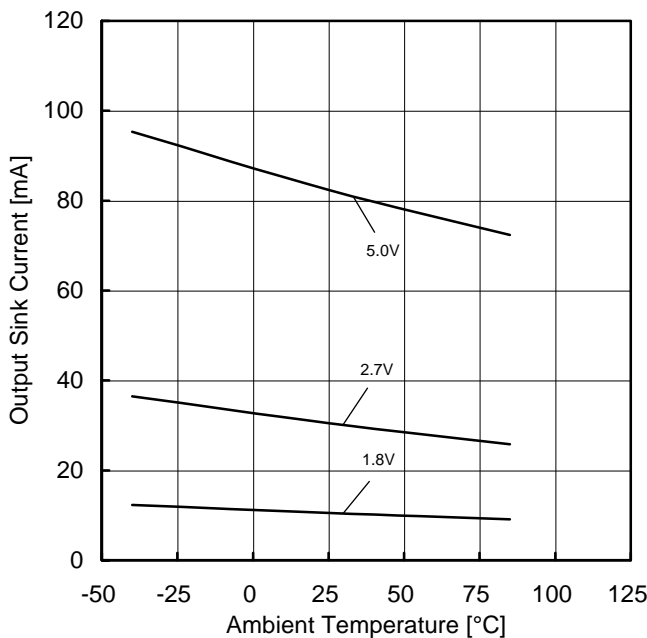

Figure 62.
Output Sink Current vs Ambient Temperature
(OUT=VDD)

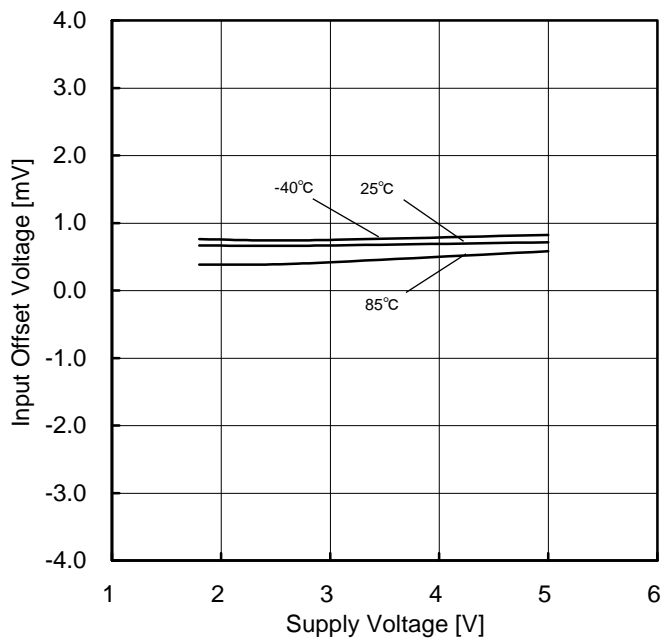

Figure 63.
Input Offset Voltage vs Supply Voltage

(Note)The data above is measurement value of typical sample, it is not guaranteed.

Typical Performance Curves (Reference data) - continued

○ LMR934xxx

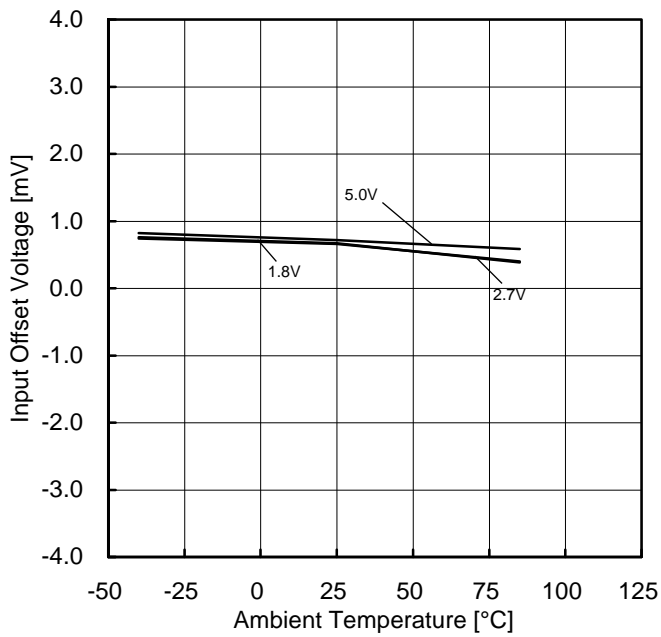

Figure 64.
Input Offset Voltage vs Ambient Temperature

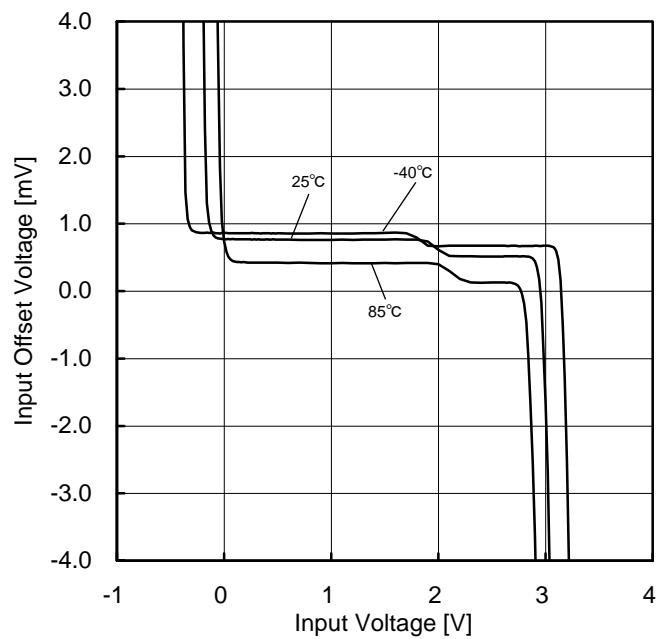

Figure 65.
Input Offset Voltage vs Input Voltage
(VDD=2.7V)

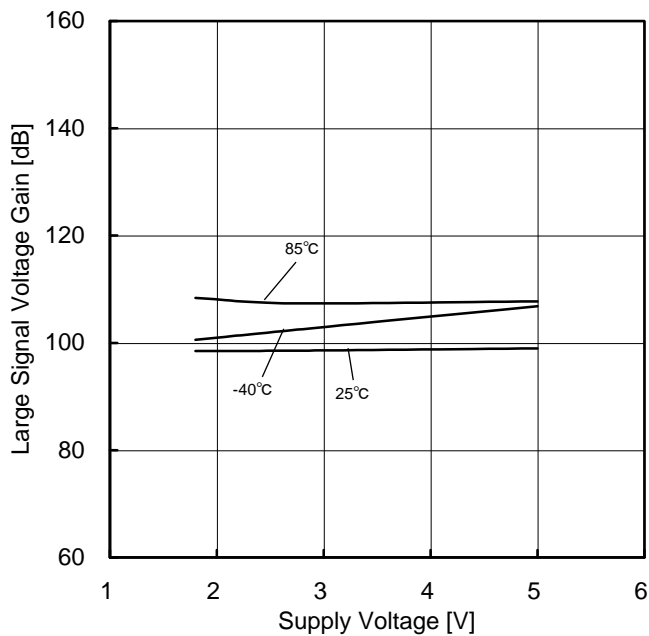

Figure 66.
Large Signal Voltage Gain vs Supply Voltage

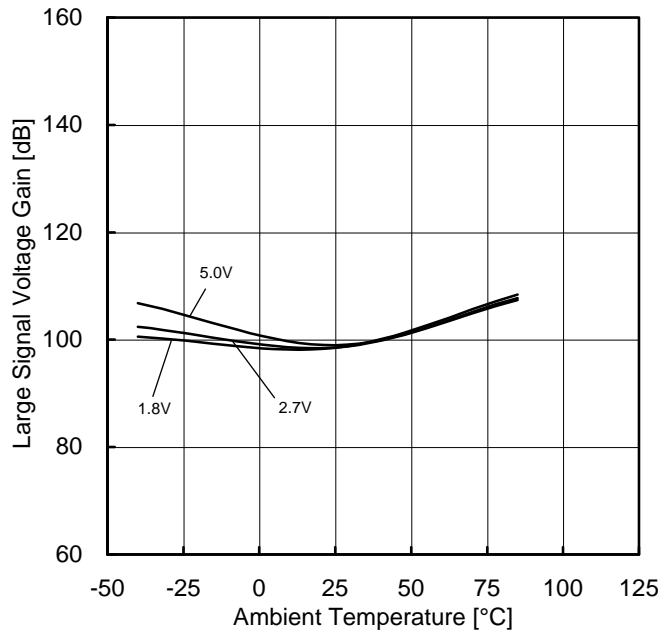

Figure 67.
Large Signal Voltage Gain vs Ambient Temperature

(Note)The data above is measurement value of typical sample, it is not guaranteed.

Typical Performance Curves (Reference data) - continued

○ LMR934xxx

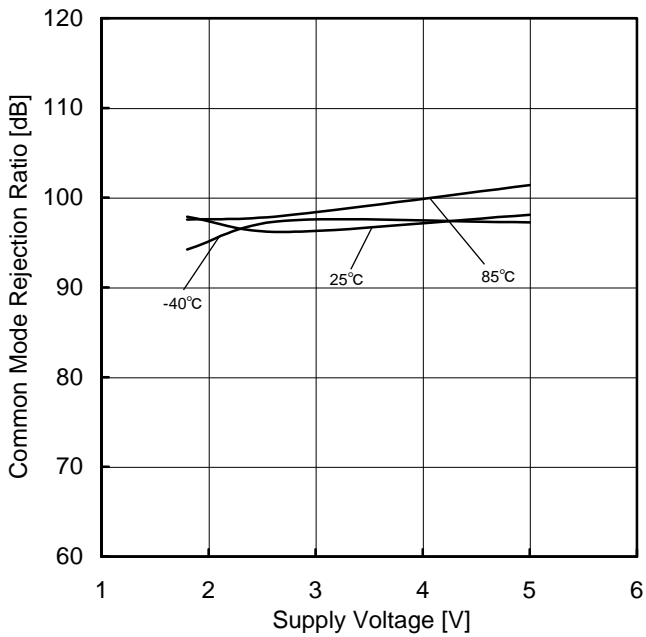

Figure 68.
Common Mode Rejection Ratio vs Supply Voltage (VDD=2.7V)

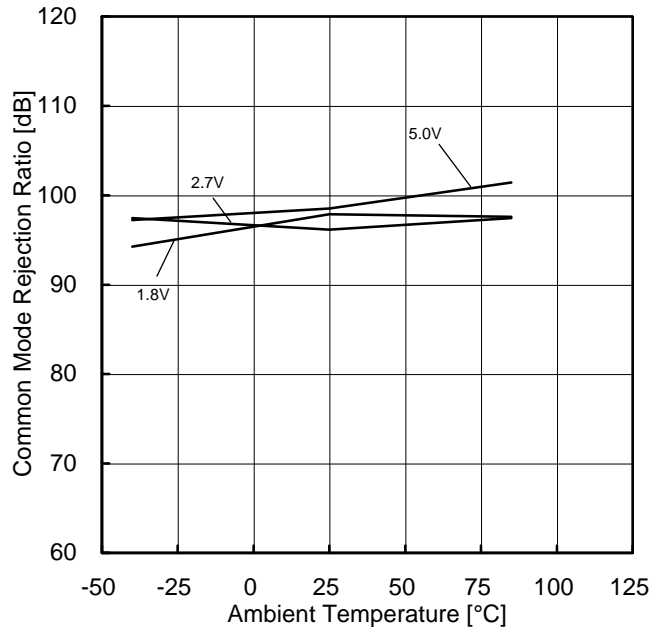

Figure 69.
Common Mode Rejection Ratio vs Ambient Temperature

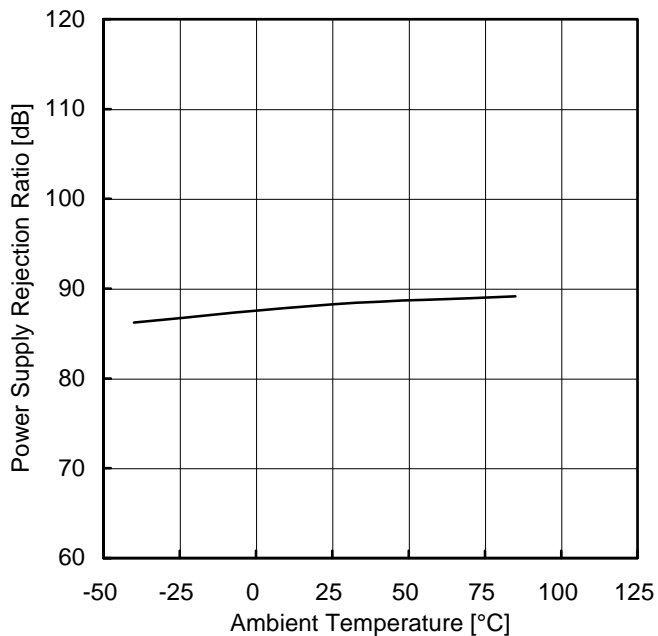

Figure 70.
Power Supply Rejection Ratio vs Ambient Temperature (VDD=1.8V to 5.0V)

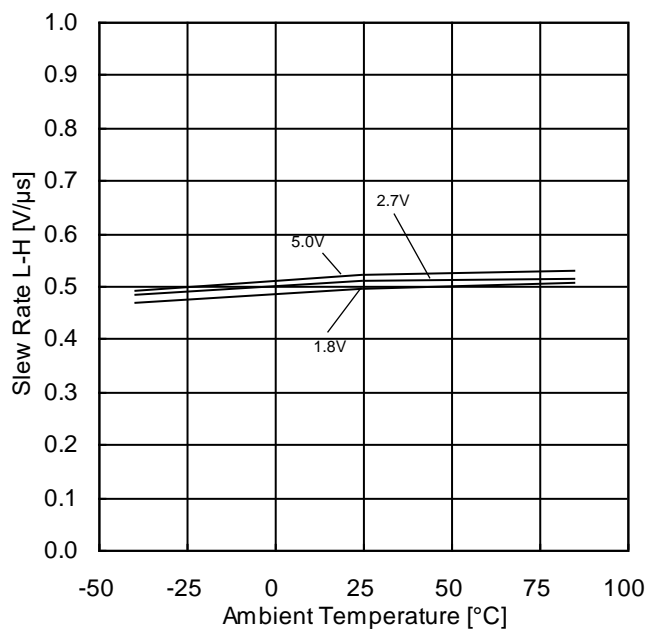

Figure 71.
Slew Rate L-H – Ambient Temperature

(Note) The data above is measurement value of typical sample, it is not guaranteed.

Typical Performance Curves (Reference data) - continued

○ LMR934xxx

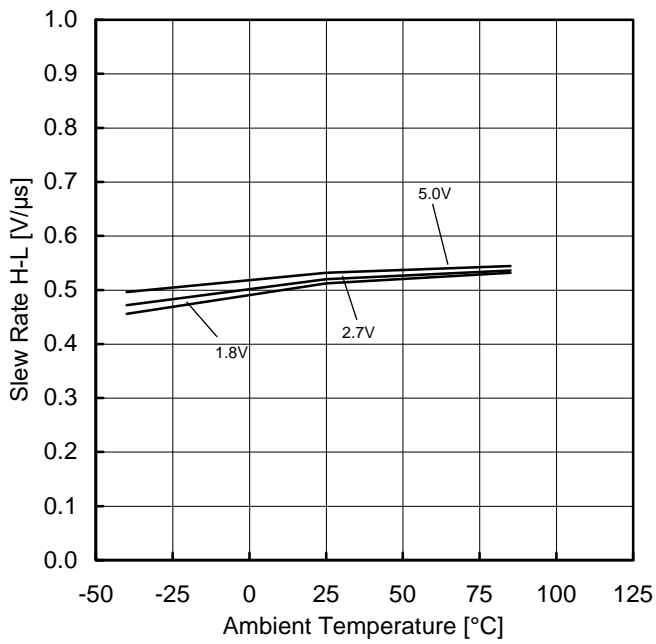

Figure 72.
Slew Rate H-L vs Ambient Temperature

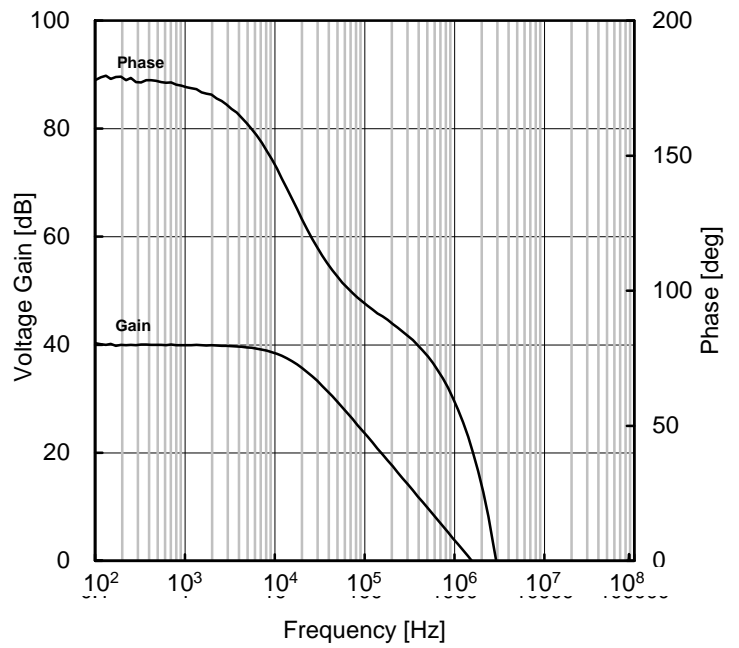

Figure 73.
Voltage Gain, Phase vs Frequency

(Note)The data above is measurement value of typical sample, it is not guaranteed.

Application Information

NULL method condition for Test circuit1

VDD, VSS, Ek, V_{ICM} Unit:V

Parameter	V _F	S1	S2	S3	VDD	VSS	E _k	V _{ICM}	Calculation
Input Offset Voltage	V _{F1}	ON	ON	OFF	3	0	-1.5	3	1
Large Signal Voltage Gain	V _{F2}	ON	ON	ON	3	0	-0.5	1.5	2
	V _{F3}						-2.5		
Common-mode Rejection Ratio (Input Common-mode Voltage Range)	V _{F4}	ON	ON	OFF	3	0	-1.5	0	3
	V _{F5}						-1.5	3	
Power Supply Rejection Ratio	V _{F6}	ON	ON	OFF	1.8	0	-1.2	0	4
	V _{F7}				5.0				

— Calculation —

1. Input Offset Voltage (V_{IO})

$$V_{IO} = \frac{|V_{F1}|}{1 + R_F/R_S} \quad [V]$$

2. Large Signal Voltage Gain (A_v)

$$A_v = 20\text{Log} \frac{\Delta E_k \times (1 + R_F/R_S)}{|V_{F2} - V_{F3}|} \quad [\text{dB}]$$

3. Common-mode Rejection Ratio (CMRR)

$$\text{CMRR} = 20\text{Log} \frac{\Delta V_{ICM} \times (1 + R_F/R_S)}{|V_{F4} - V_{F5}|} \quad [\text{dB}]$$

4. Power Supply Rejection Ratio (PSRR)

$$\text{PSRR} = 20\text{Log} \frac{\Delta V_{CC} \times (1 + R_F/R_S)}{|V_{F6} - V_{F7}|} \quad [\text{dB}]$$

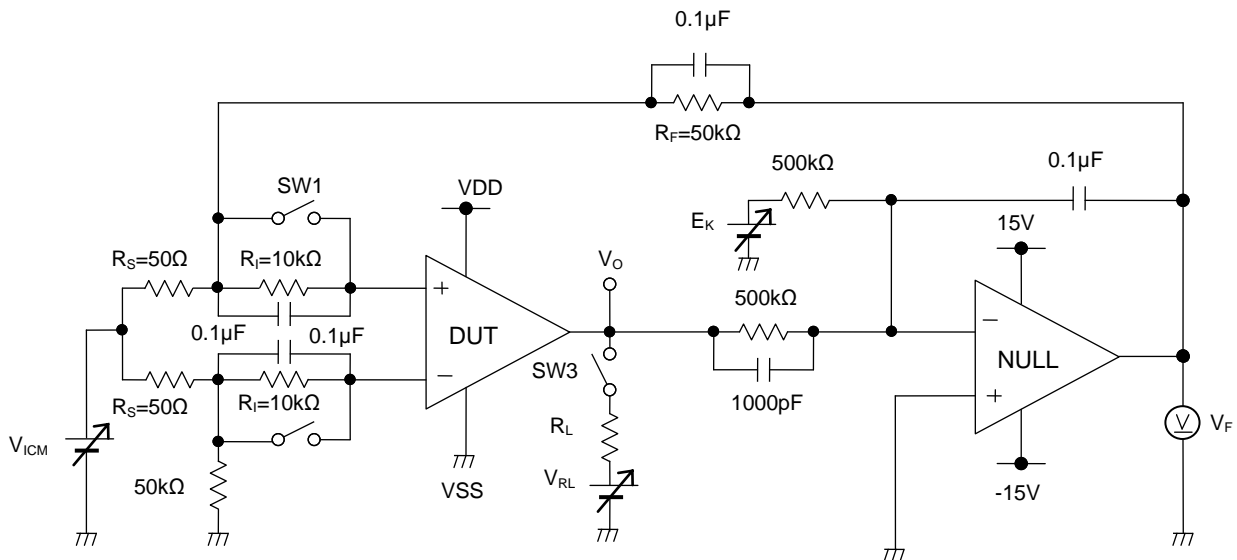

Figure 74. Test Circuit 1

Switch Condition for Test Circuit 2

SW No.	SW1	SW2	SW3	SW4	SW5	SW6	SW7	SW8	SW9	SW10	SW11	SW12
Supply Current	OFF	OFF	ON	OFF	ON	OFF	OFF	OFF	OFF	OFF	OFF	OFF
Maximum Output Voltage $R_L=10k\Omega$	OFF	ON	OFF	OFF	ON	OFF	OFF	ON	OFF	OFF	ON	OFF
Output Current	OFF	ON	OFF	OFF	ON	OFF	OFF	OFF	OFF	ON	OFF	OFF
Slew Rate	OFF	OFF	ON	OFF	OFF	OFF	ON	OFF	ON	OFF	OFF	ON
Unity Gain Frequency	ON	OFF	OFF	ON	ON	OFF	OFF	OFF	ON	OFF	OFF	ON

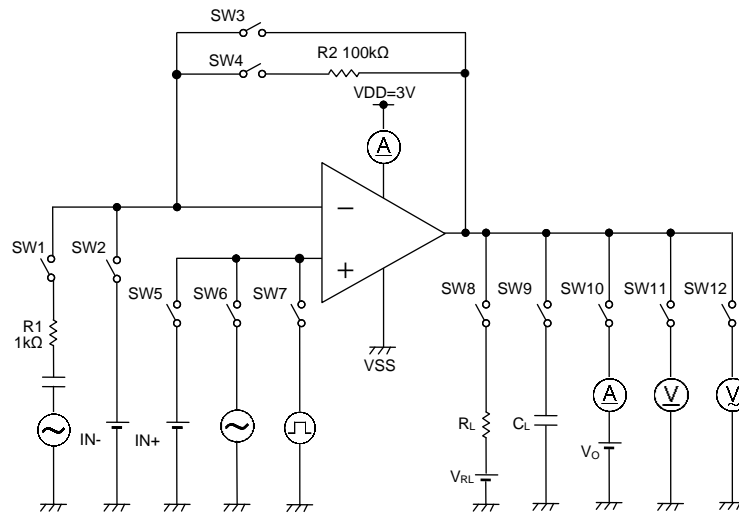

Figure 75. Test Circuit2

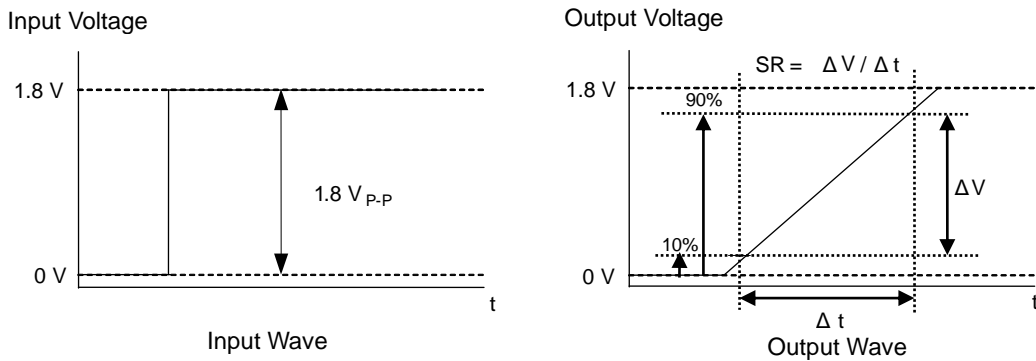

Figure 76. Slew Rate Input Output Wave

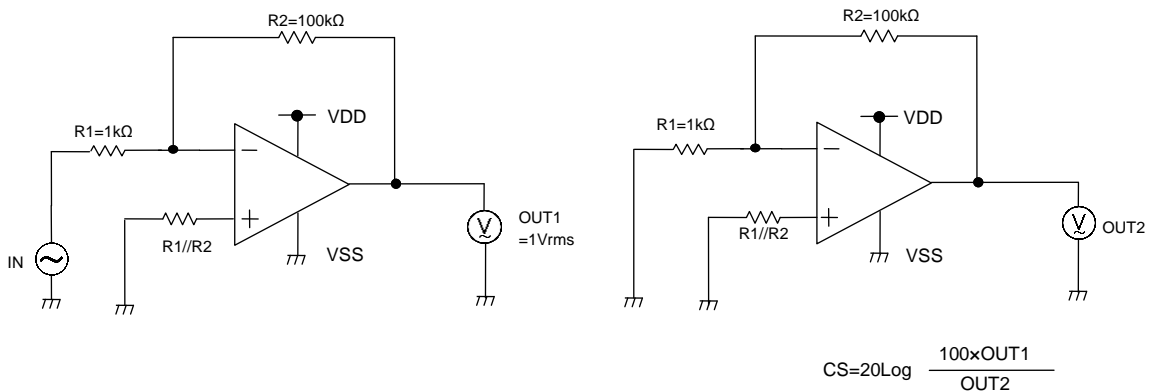

Figure 77. Test Circuit 3 (Channel Separation)

Application Example

○Voltage Follower

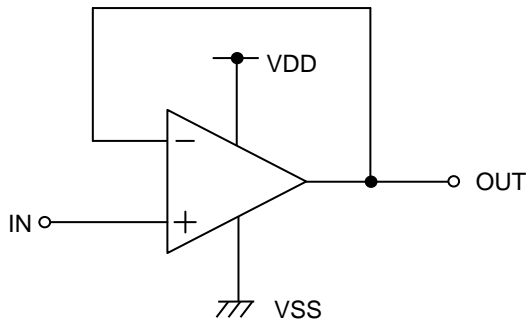

Figure 78. Voltage Follower

Voltage gain is 0dB.

This circuit controls output voltage (OUT) equal input voltage (IN), and keeps OUT with stable because of high input impedance and low output impedance. OUT is shown next expression.

$$OUT=IN$$

○Inverting Amplifier

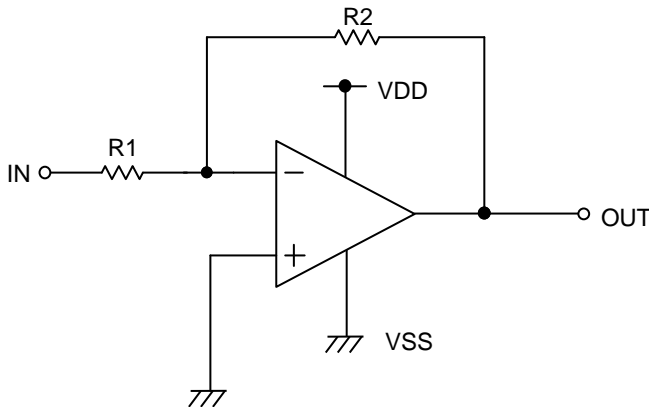

Figure 79. Inverting Amplifier Circuit

For inverting amplifier, IN is amplified by voltage gain decided R1 and R2, and phase reversed voltage is output. OUT is shown next expression.

$$OUT=-\left(\frac{R2}{R1}\right) \times IN$$

Input impedance is R1.

○Non-inverting amplifier

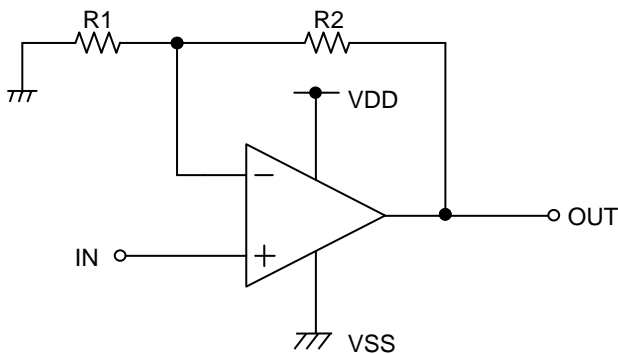

Figure 80. Non-inverting Amplifier Circuit

For non-inverting amplifier, IN is amplified by voltage gain decided R1 and R2, and phase is same with IN. OUT is shown next expression.

$$OUT=\left(1+\frac{R2}{R1}\right) \times IN$$

This circuit performs high input impedance because Input impedance is operational amplifier's input Impedance.

Power Dissipation

Power dissipation (total loss) indicates the power that the IC can consume at $T_A=25^{\circ}\text{C}$ (normal temperature). As the IC consumes power, it heats up, causing its temperature to be higher than the ambient temperature. The allowable temperature that the IC can accept is limited. This depends on the circuit configuration, manufacturing process, and consumable power.

Power dissipation is determined by the allowable temperature within the IC (maximum junction temperature) and the thermal resistance of the package used (heat dissipation capability). Maximum junction temperature is typically equal to the maximum storage temperature. The heat generated through the consumption of power by the IC radiates from the mold resin or lead frame of the package. Thermal resistance, represented by the symbol $\theta_{JA}^{\circ}\text{C/W}$, indicates this heat dissipation capability. Similarly, the temperature of an IC inside its package can be estimated by thermal resistance.

Figure 81(a) shows the model of the thermal resistance of a package. The equation below shows how to compute for the Thermal resistance (θ_{JA}), given the ambient temperature (T_A), maximum junction temperature (T_{Jmax}), and power dissipation (P_D).

$$\theta_{JA} = (T_{Jmax} - T_A) / P_D \quad ^{\circ}\text{C/W}$$

The derating curve in Figure 81(b) indicates the power that the IC can consume with reference to ambient temperature. Power consumption of the IC begins to attenuate at certain temperatures. This gradient is determined by Thermal resistance (θ_{JA}), which depends on the chip size, power consumption, package, ambient temperature, package condition, wind velocity, etc. This may also vary even when the same of package is used. Thermal reduction curve indicates a reference value measured at a specified condition. Figure 81(c) to (e) shows an example of the derating curve for LMR981G, LMR931G, LMR982FVM, LMR932xxx and LMR934xxx.

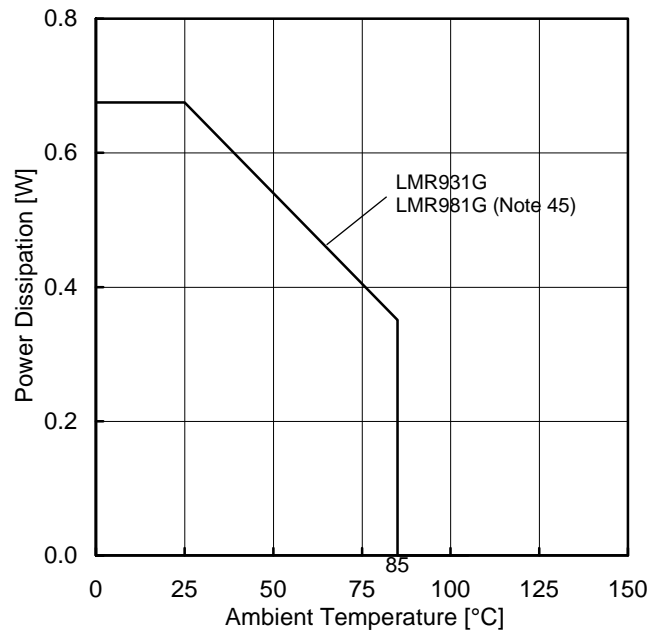
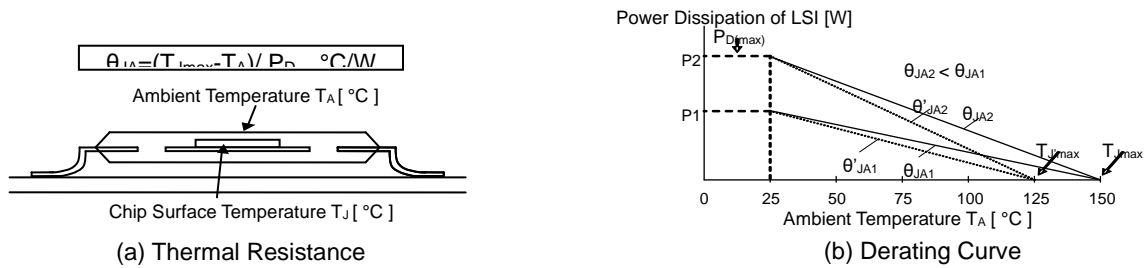

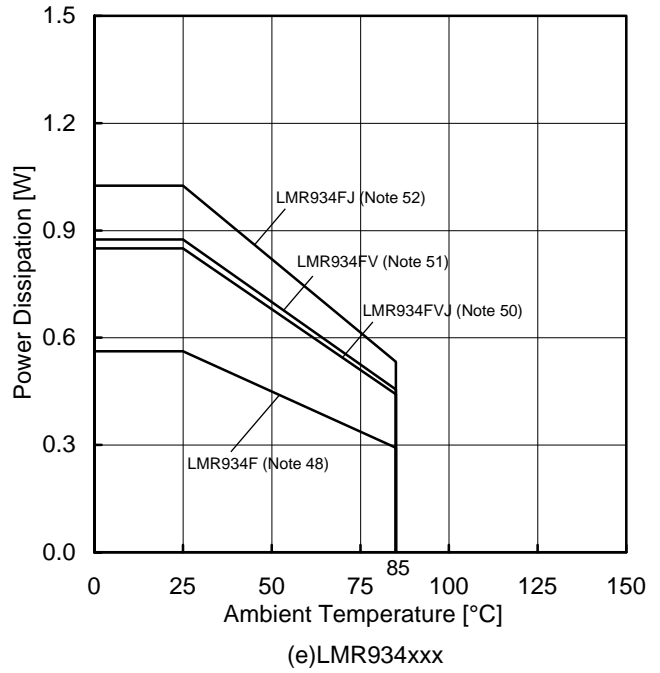
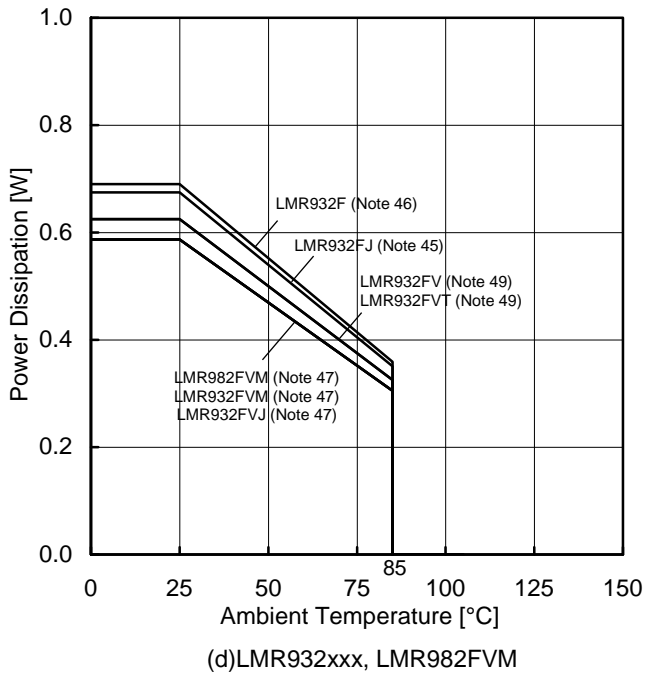

Figure 81. Thermal Resistance and Derating Curve

(Note 45)	(Note 46)	(Note 47)	(Note 48)	(Note 49)	(Note 50)	(Note 51)	(Note 52)	Unit
5.4	5.5	4.7	4.5	5.0	6.8	7.0	8.2	mW/°C

When using the unit above $T_A=25^\circ\text{C}$, subtract the value above per Celsius degree. Permissible dissipation is the value when FR4 glass epoxy board 70mm × 70mm × 1.6mm (copper foil area less than 3%) is mounted

Operational Notes

1. Reverse Connection of Power Supply

Connecting the power supply in reverse polarity can damage the IC. Take precautions against reverse polarity when connecting the power supply, such as mounting an external diode between the power supply and the IC's power supply pins.

2. Power Supply Lines

Design the PCB layout pattern to provide low impedance supply lines. Separate the ground and supply lines of the digital and analog blocks to prevent noise in the ground and supply lines of the digital block from affecting the analog block. Furthermore, connect a capacitor to ground at all power supply pins. Consider the effect of temperature and aging on the capacitance value when using electrolytic capacitors.

3. Ground Voltage

Ensure that no pins are at a voltage below that of the ground pin at any time, even during transient condition.

4. Ground Wiring Pattern

When using both small-signal and large-current ground traces, the two ground traces should be routed separately but connected to a single ground at the reference point of the application board to avoid fluctuations in the small-signal ground caused by large currents. Also ensure that the ground traces of external components do not cause variations on the ground voltage. The ground lines must be as short and thick as possible to reduce line impedance.

5. Thermal Consideration

Should by any chance the power dissipation rating be exceeded the rise in temperature of the chip may result in deterioration of the properties of the chip. The absolute maximum rating of the P_D stated in this specification is when the IC is mounted on a 70mm x 70mm x 1.6mm glass epoxy board. In case of exceeding this absolute maximum rating, increase the board size and copper area to prevent exceeding the P_D rating.

6. Recommended Operating Conditions

These conditions represent a range within which the expected characteristics of the IC can be approximately obtained. The electrical characteristics are guaranteed under the conditions of each parameter.

7. Inrush Current

When power is first supplied to the IC, it is possible that the internal logic may be unstable and inrush current may flow instantaneously due to the internal powering sequence and delays, especially if the IC has more than one power supply. Therefore, give special consideration to power coupling capacitance, power wiring, width of ground wiring, and routing of connections.

8. Operation Under Strong Electromagnetic Field

Operating the IC in the presence of a strong electromagnetic field may cause the IC to malfunction.

9. Testing on Application Boards

When testing the IC on an application board, connecting a capacitor directly to a low-impedance output pin may subject the IC to stress. Always discharge capacitors completely after each process or step. The IC's power supply should always be turned off completely before connecting or removing it from the test setup during the inspection process. To prevent damage from static discharge, ground the IC during assembly and use similar precautions during transport and storage.

10. Inter-pin Short and Mounting Errors

Ensure that the direction and position are correct when mounting the IC on the PCB. Incorrect mounting may result in damaging the IC. Avoid nearby pins being shorted to each other especially to ground, power supply and output pin. Inter-pin shorts could be due to many reasons such as metal particles, water droplets (in very humid environment) and unintentional solder bridge deposited in between pins during assembly to name a few.

11. Regarding the Input Pin of the IC

This monolithic IC contains P+ isolation and P substrate layers between adjacent elements in order to keep them isolated. P-N junctions are formed at the intersection of the P layers with the N layers of other elements, creating a parasitic diode or transistor. For example (refer to Figure 82):

When $GND > Pin A$ and $GND > Pin B$, the P-N junction operates as a parasitic diode.

When $GND > Pin B$, the P-N junction operates as a parasitic transistor.

Operational Notes – continued

Parasitic diodes inevitably occur in the structure of the IC. The operation of parasitic diodes can result in mutual interference among circuits, operational faults, or physical damage. Therefore, conditions that cause these diodes to operate, such as applying a voltage lower than the GND voltage to an input pin (and thus to the P substrate) should be avoided.

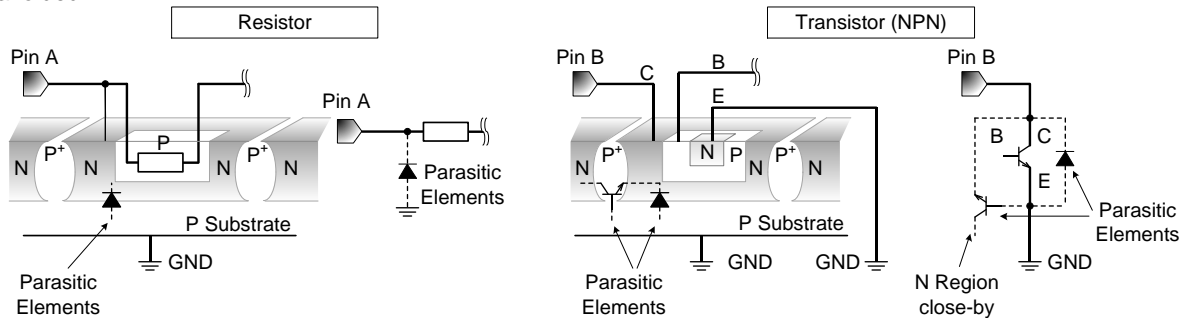

Figure 82. Example of Monolithic IC Structure

12. Unused Circuits

When there are unused op-amps, it is recommended that they are connected as in Figure 83, setting the non-inverting input terminal to a potential within the in-phase input voltage range (V_{ICM}).

13. Input Voltage

Applying $VSS+0.3V$ to the input terminal is possible without causing deterioration of the electrical characteristics or destruction, regardless of the supply voltage. However, this does not ensure normal circuit operation. Please note that the circuit operates normally only when the input voltage is within the common mode input voltage range of the electric characteristics.

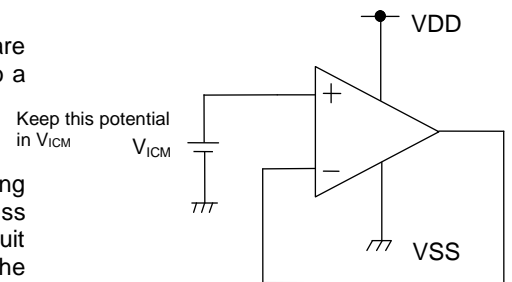

Figure 83. Example of Application Circuit for Unused Op-Amp

14. Power Supply(single/dual)

The operational amplifiers operate when the voltage supplied is between VDD and VSS. Therefore, the single supply operational amplifiers can be used as dual supply operational amplifiers as well.

15. Output Capacitor

If a large capacitor is connected between the output pin and VSS pin, current from the charged capacitor will flow into the output pin and may destroy the IC when the VDD pin is shorted to ground or pulled down to 0V. Use a capacitor smaller than 0.1 μF between output pin and VSS pin.

16. Oscillation by Output Capacitor

Please pay attention to the oscillation by output capacitor and in designing an application of negative feedback loop circuit with these ICs.

17. Latch up

Be careful of input voltage that exceed the VDD and VSS. When CMOS device have sometimes occur latch up and protect the IC from abnormally noise.

18. Decoupling Capacitor

Insert the decoupling capacitance between VDD and VSS, for stable operation of operational amplifier.

19. Shutdown Terminal

The shutdown terminal can't be left unconnected. In case shutdown operation is not needed, the shutdown pin should be connected to VDD when the IC is used. Leaving the shutdown pin floating will result in an undefined operation mode, either shutdown or active, or even oscillating between the two modes.

Physical Dimension, Tape and Reel Information

Package Name	SSOP5
--------------	-------

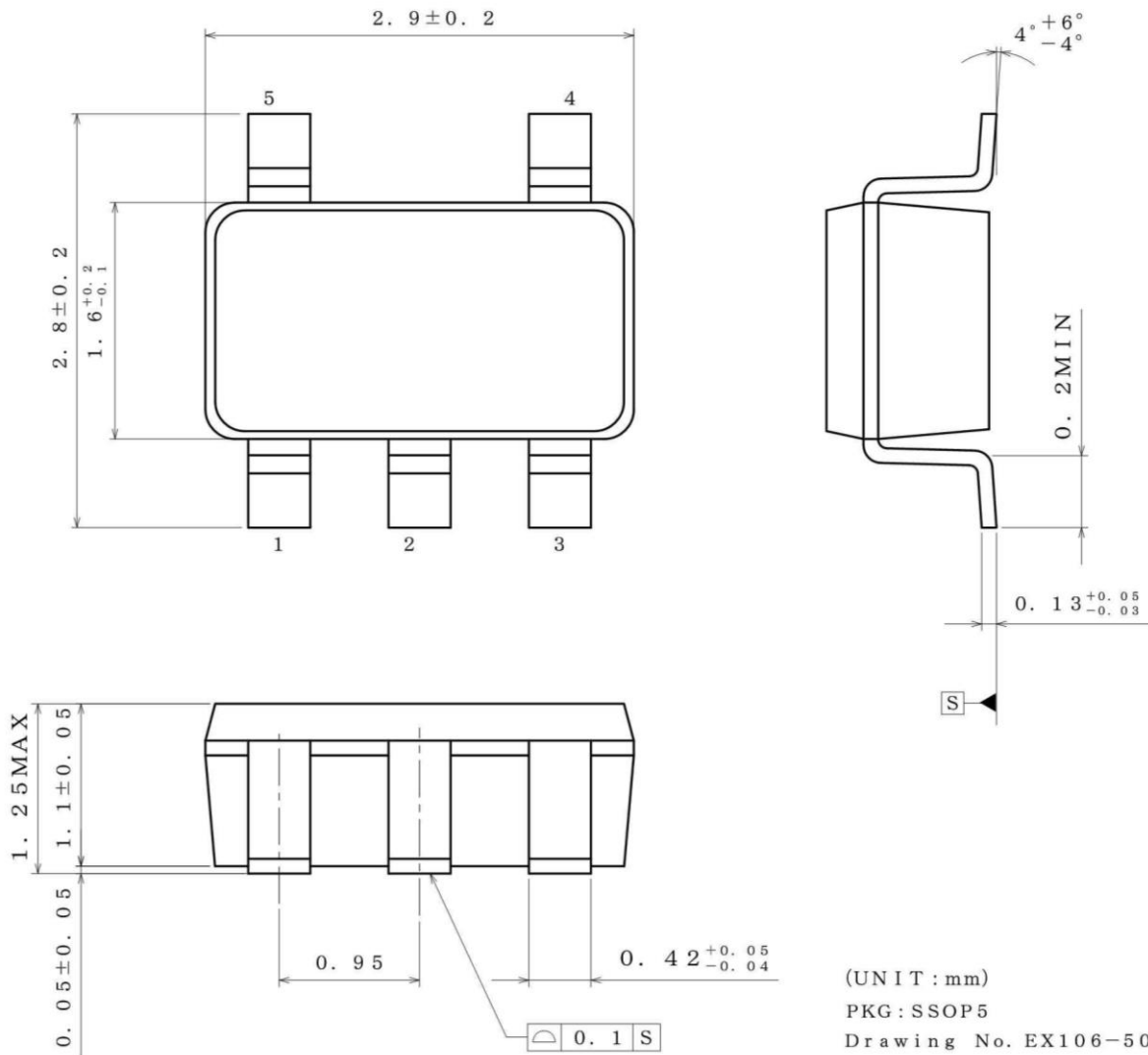

< Tape and Reel Information >

Tape	Embossed carrier tape
Quantity	3000pcs
Direction of feed	TR (The direction is the 1pin of product is at the upper right when you hold reel on the left hand and you pull out the tape on the right hand)

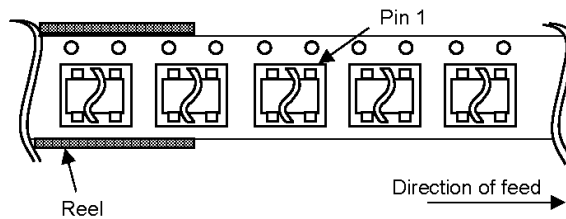

Physical Dimension Tape and Reel Information – continued

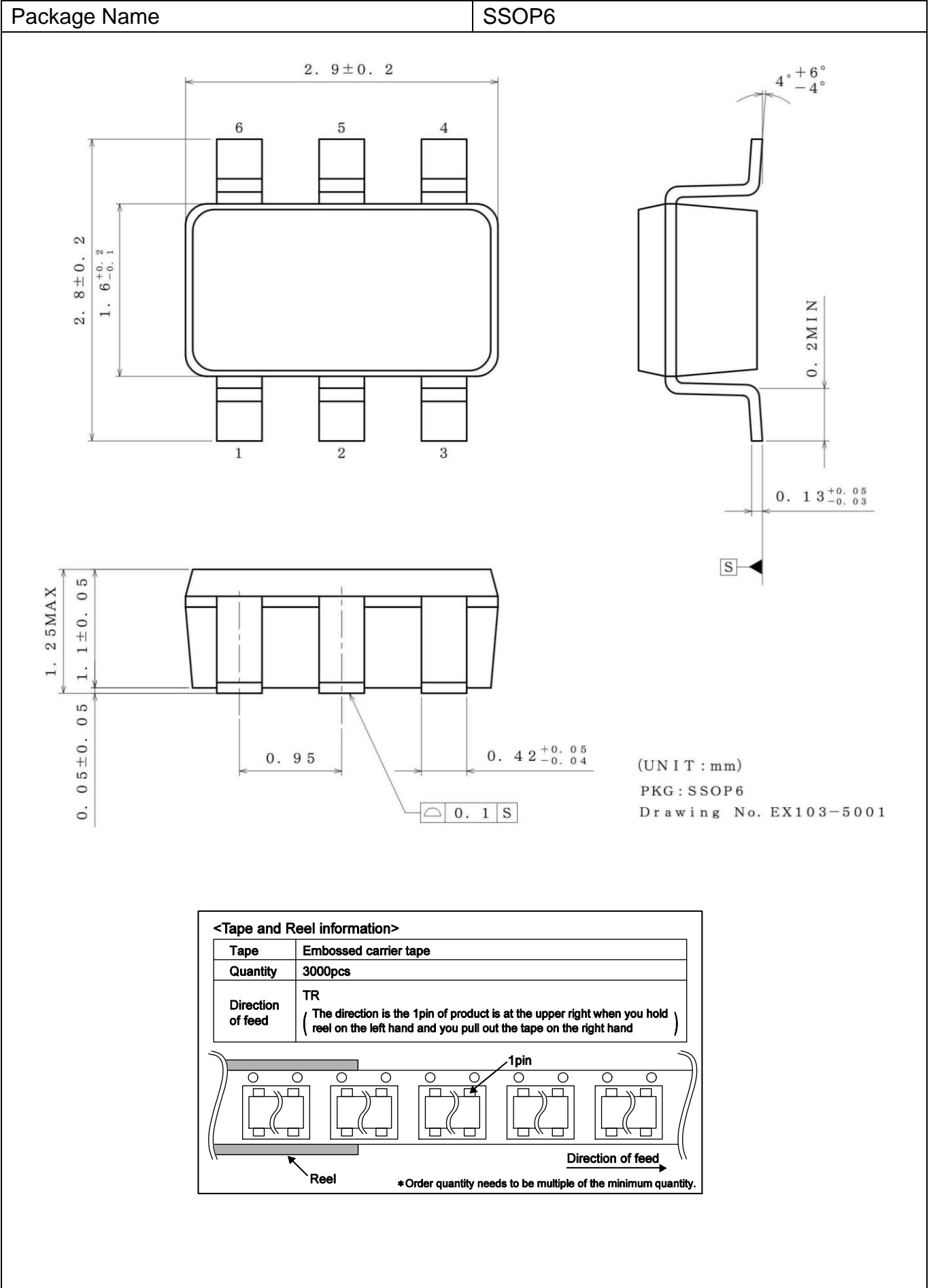

Physical Dimension Tape and Reel Information – continued

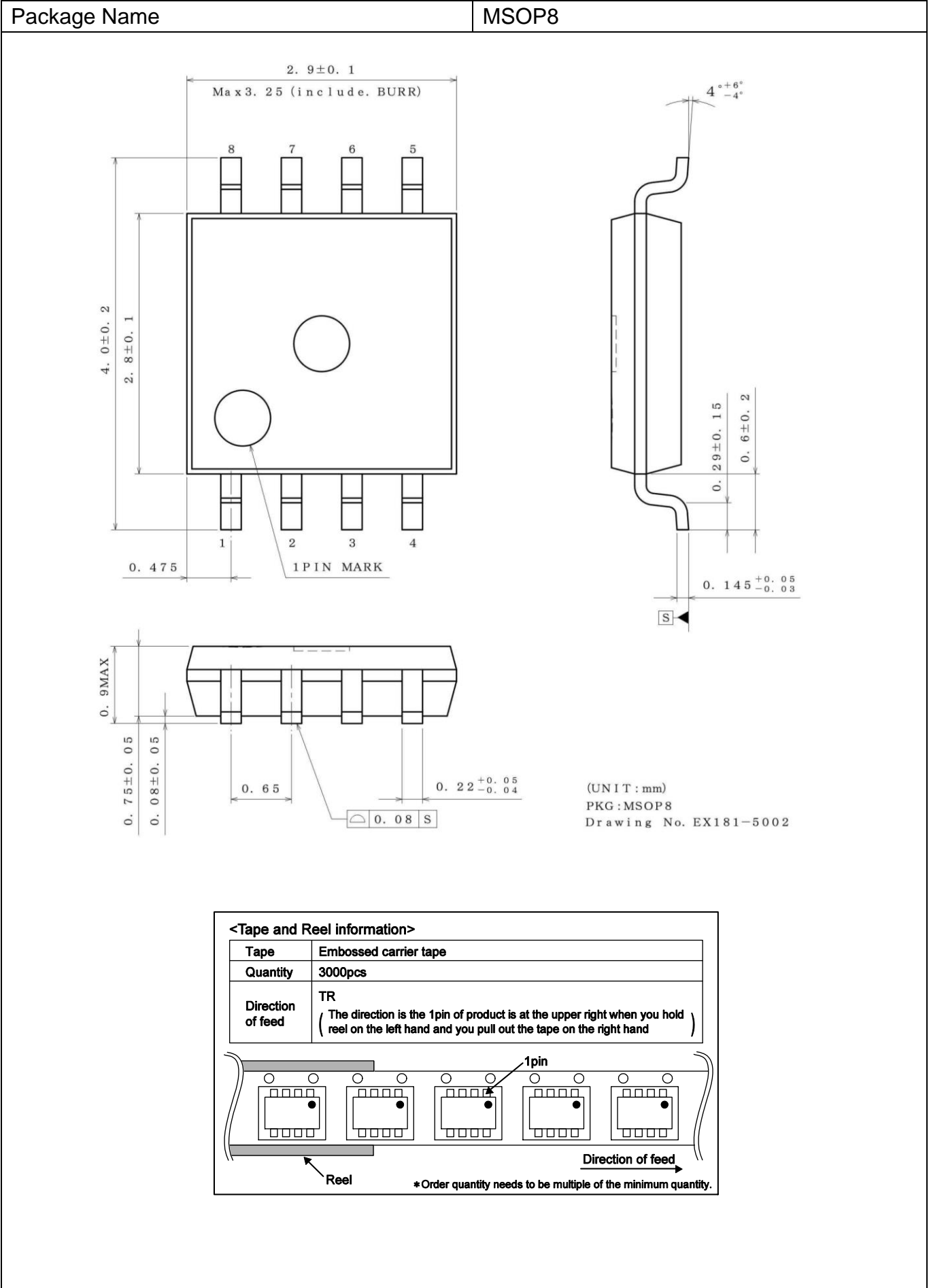

Physical Dimension Tape and Reel Information – continued

Package Name	MSOP10
--------------	--------

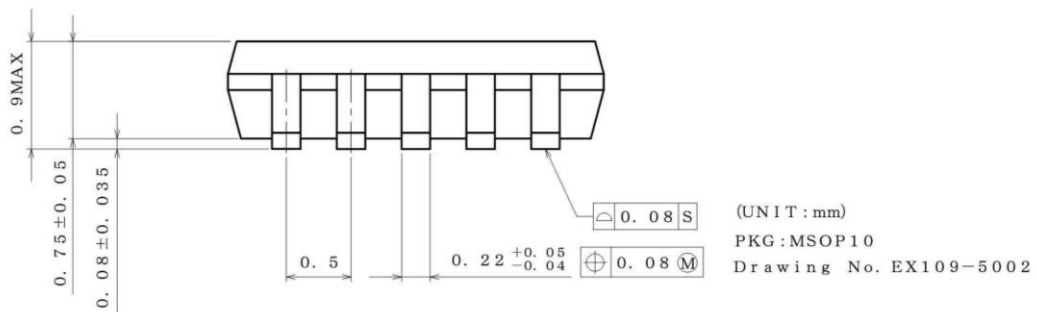
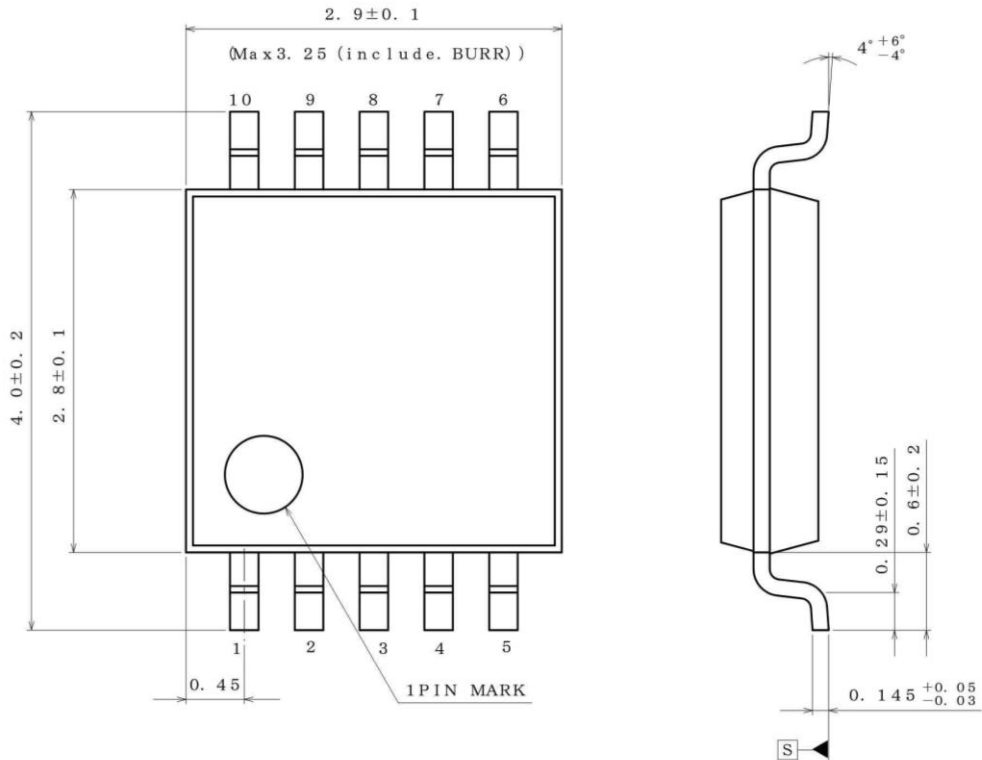

< Tape and Reel Information >

Tape	Embossed carrier tape
Quantity	3000pcs
Direction of feed	TR (The direction is the pin 1 of product is at the upper right when you hold reel on the left hand and you pull out the tape on the right hand)

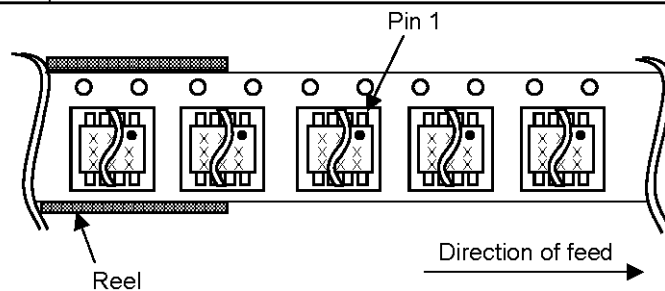

Physical Dimension Tape and Reel Information – continued

Package Name	TSSOP-B8J
--------------	-----------

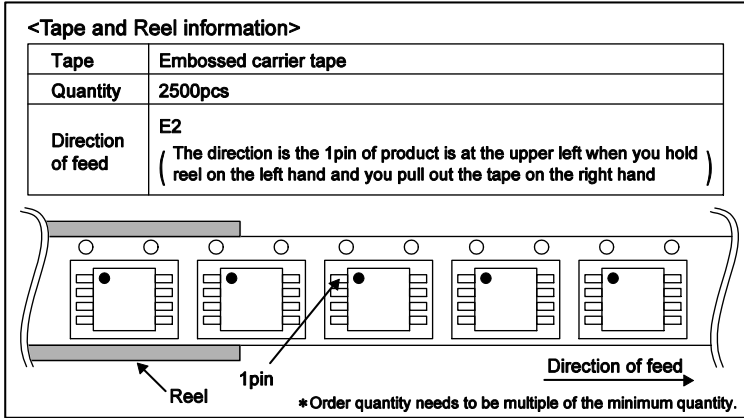
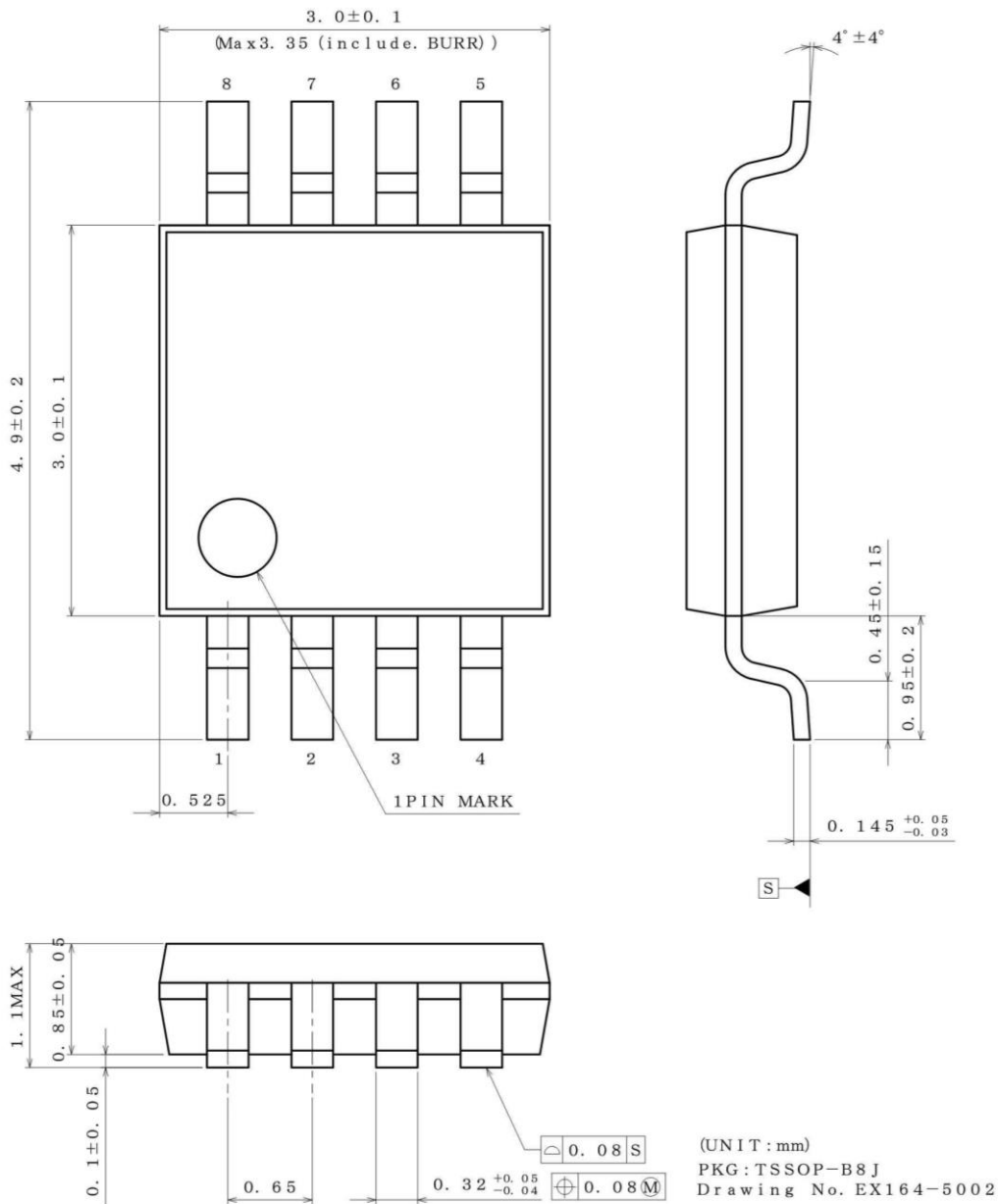

Physical Dimension Tape and Reel Information – continued

Package Name	TSSOP-B8
--------------	----------

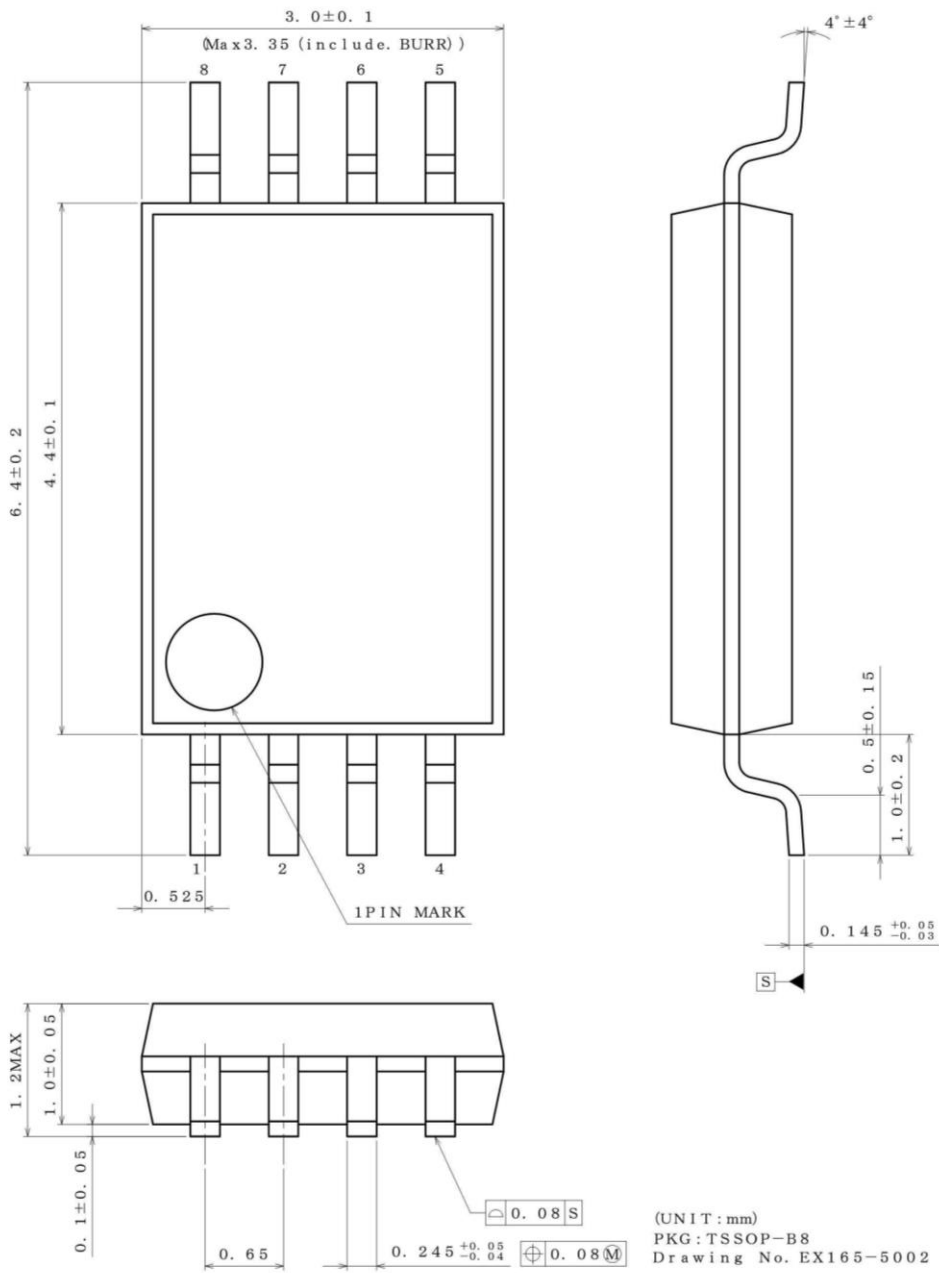

<Tape and Reel information>

Tape	Embossed carrier tape
Quantity	3000pcs
Direction of feed	E2 (The direction is the 1pin of product is at the upper left when you hold reel on the left hand and you pull out the tape on the right hand)

Reel → 1pin → Direction of feed

*Order quantity needs to be multiple of the minimum quantity.

Physical Dimension Tape and Reel Information – continued

Package Name	SSOP-B8
--------------	---------

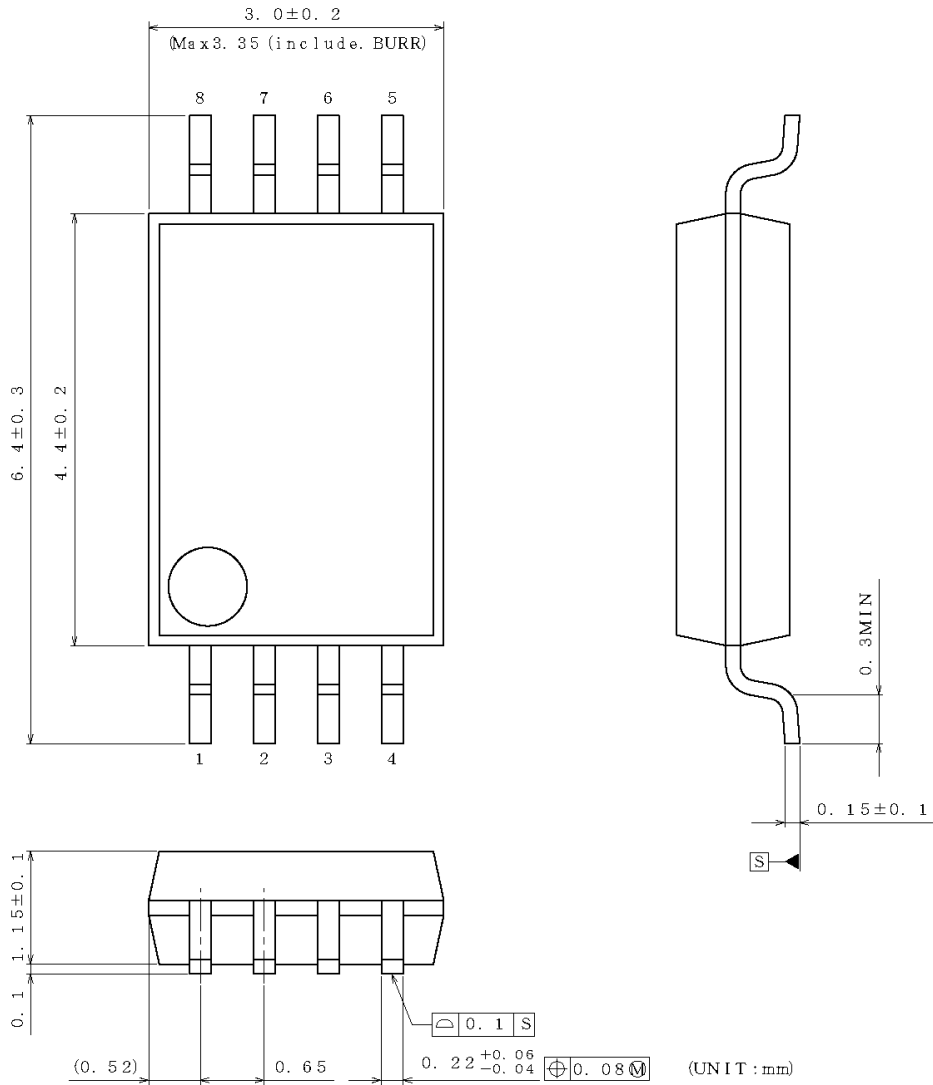

(UNIT : mm)
 PKG : SSOP-B8
 Drawing No. EX151-5002

<Tape and Reel information>

Tape	Embossed carrier tape
Quantity	2500pcs
Direction of feed	E2 (The direction is the 1pin of product is at the upper left when you hold reel on the left hand and you pull out the tape on the right hand)

Diagram of the embossed carrier tape showing the direction of feed and the location of the 1st pin.

- The diagram shows a series of carrier tape pockets, each containing a component.
- An arrow labeled "Reel" points to the left, indicating the direction of the tape.
- An arrow labeled "Direction of feed" points to the right.
- A dot in the first pocket is labeled "1pin".
- A note below the diagram states: "*Order quantity needs to be multiple of the minimum quantity."

Physical Dimension Tape and Reel Information – continued

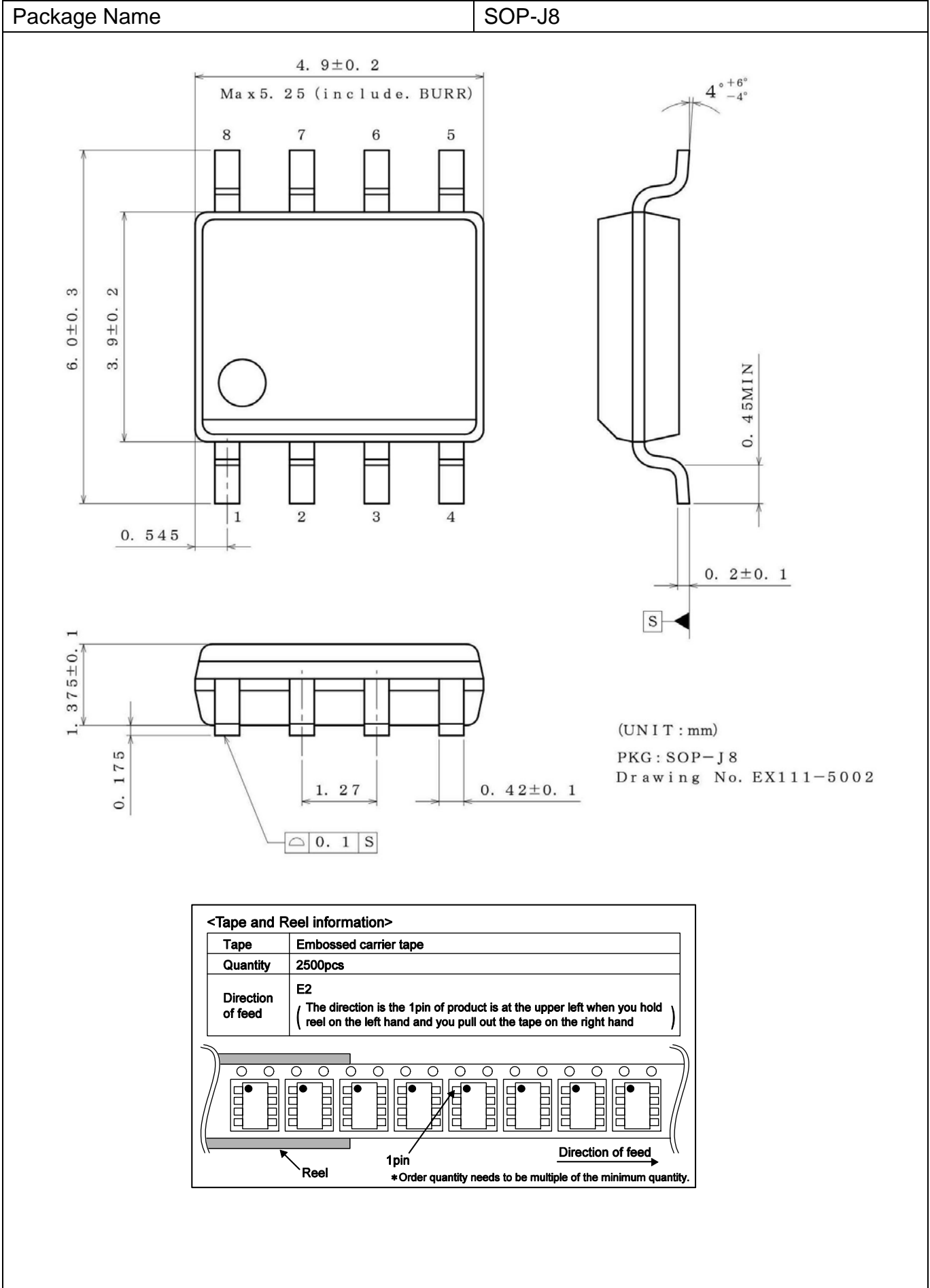

Physical Dimension Tape and Reel Information – continued

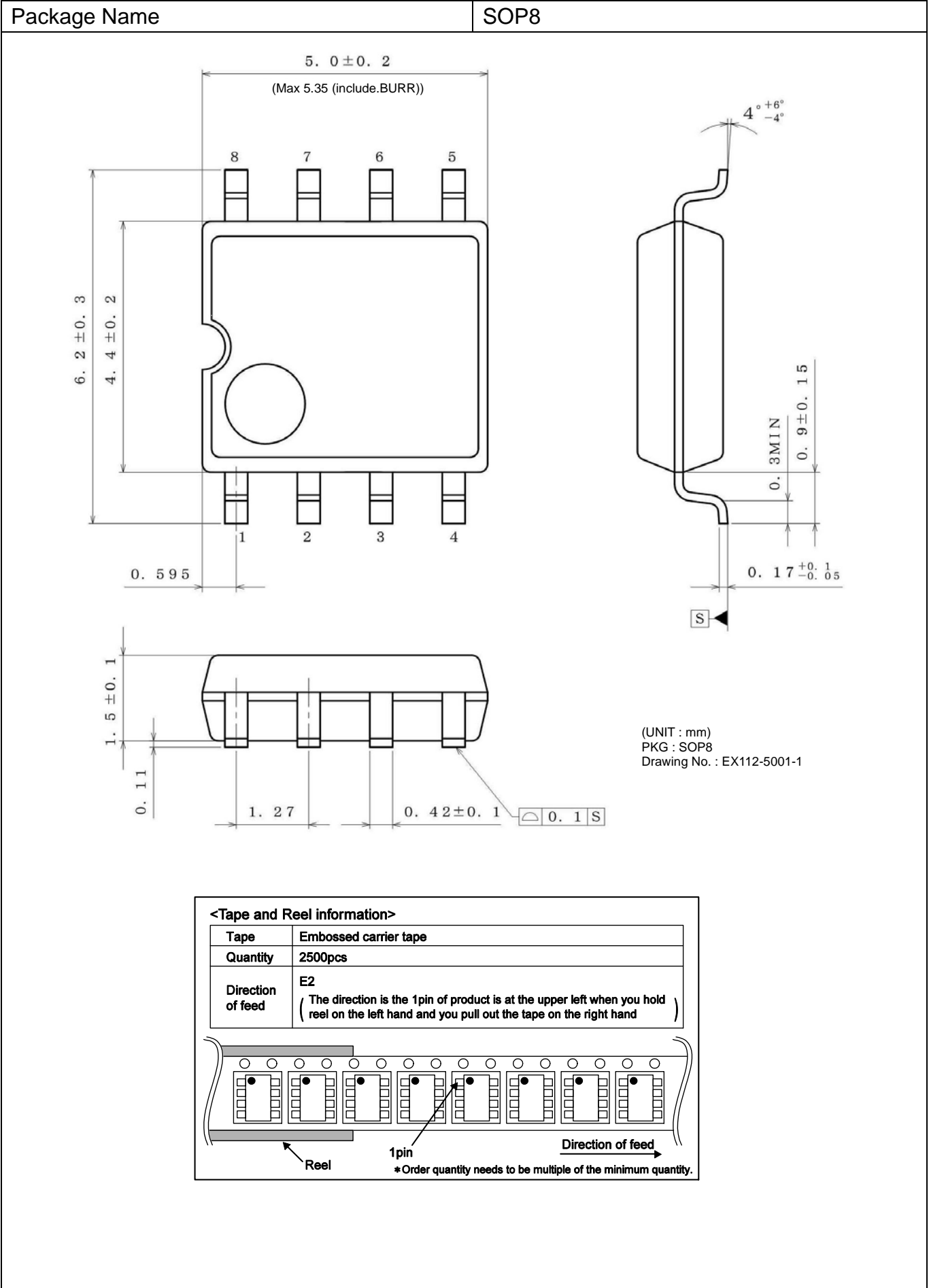

Physical Dimension Tape and Reel Information – continued

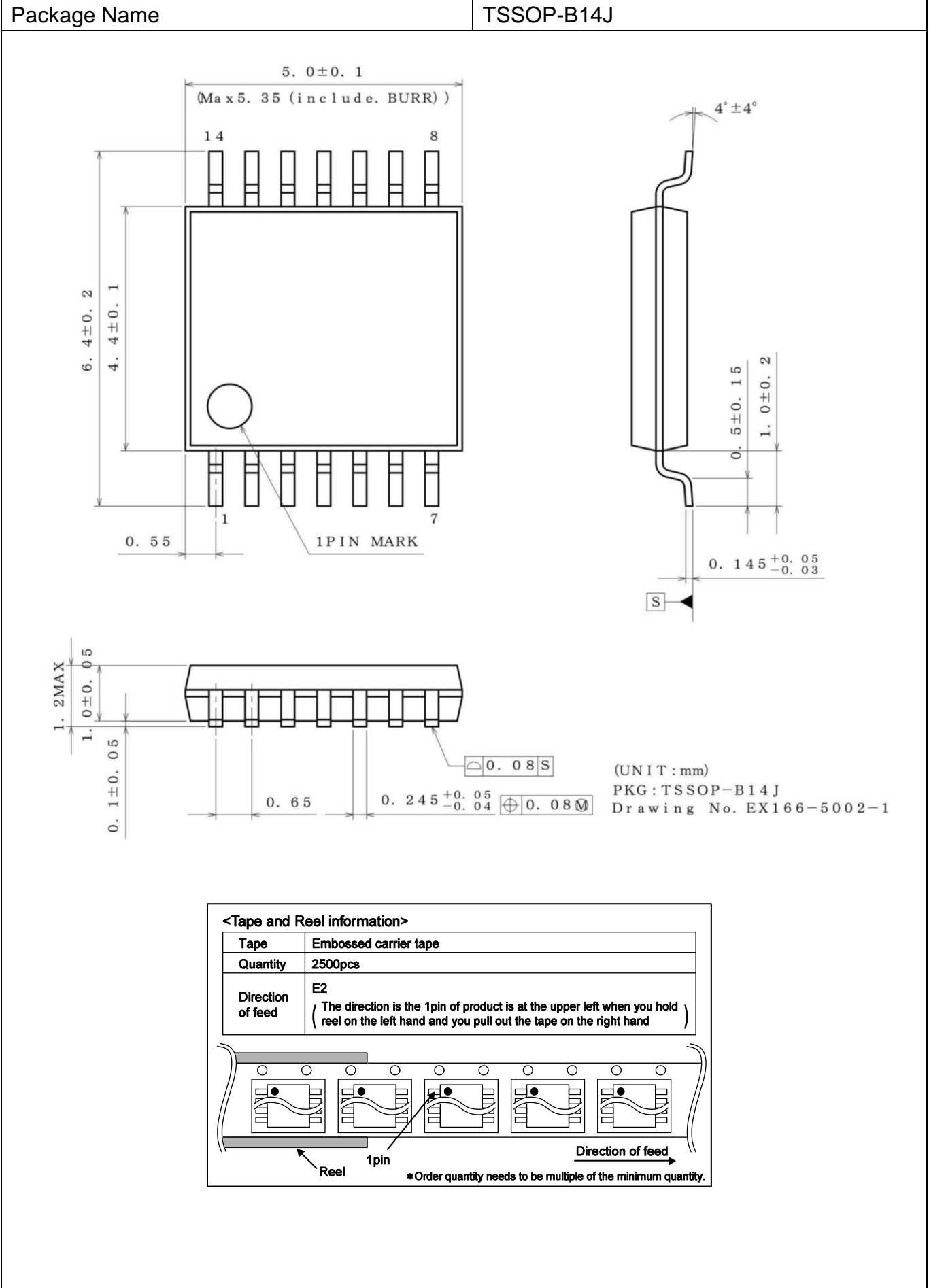

Physical Dimension Tape and Reel Information – continued

Package Name	SSOP-B14
--------------	----------

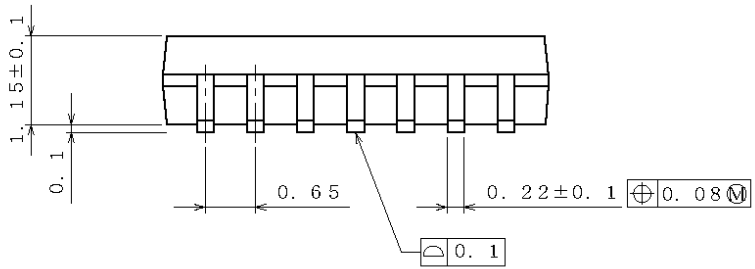
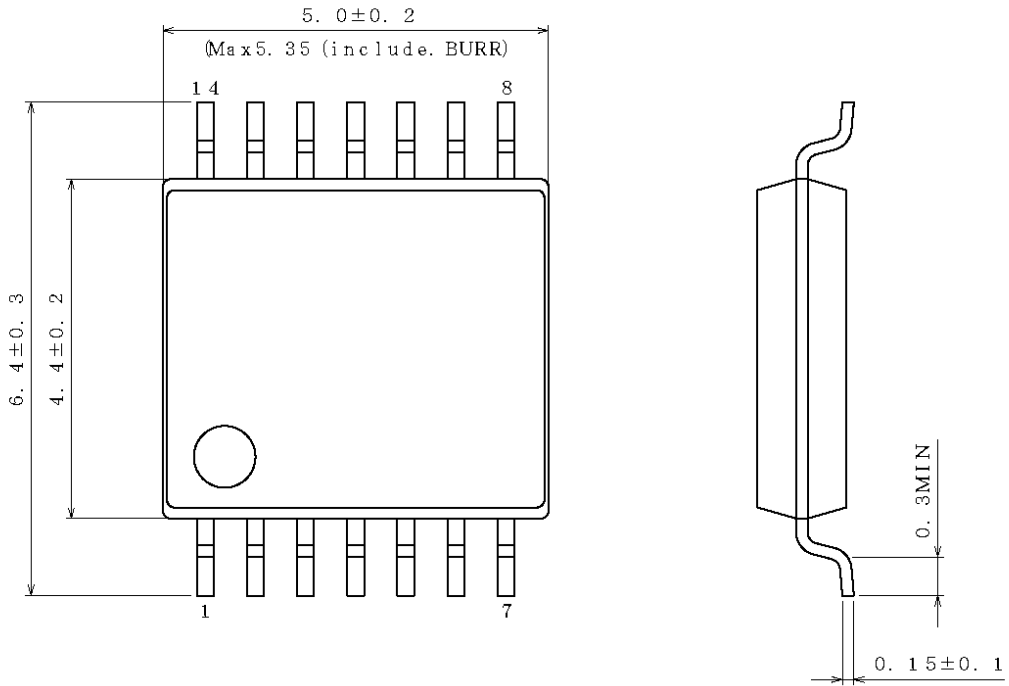

(UNIT : mm)
 PKG : SSOP-B14
 Drawing No. EX152-5002

<Tape and Reel information>

Tape	Embossed carrier tape
Quantity	2500pcs
Direction of feed	E2 (The direction is the 1pin of product is at the upper left when you hold reel on the left hand and you pull out the tape on the right hand)

1pin
 *Order quantity needs to be multiple of the minimum quantity.

Physical Dimension Tape and Reel Information – continued

Package Name	SOP14
--------------	-------

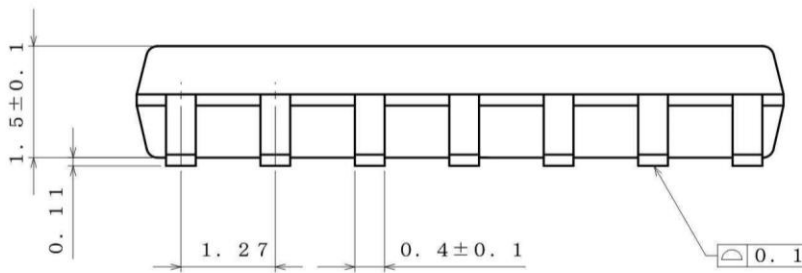
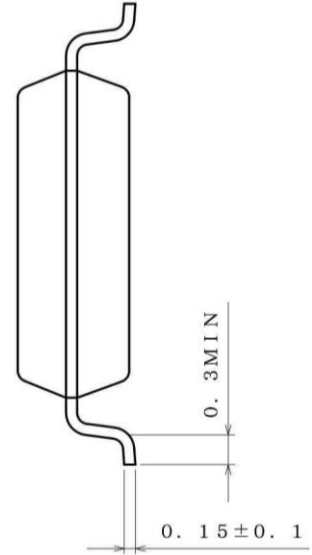
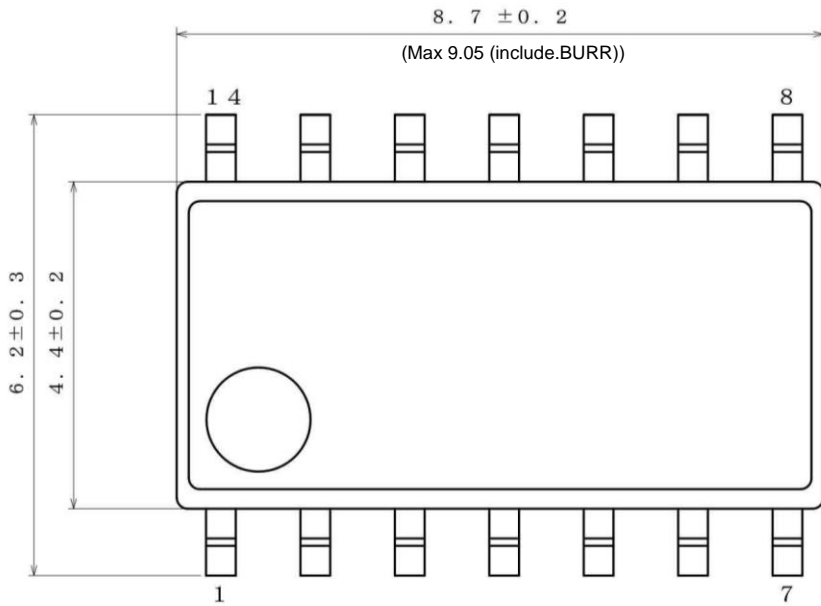

(UNIT : mm)
 PKG : SOP14
 Drawing No. : EX113-5001

<Tape and Reel information>

Tape	Embossed carrier tape
Quantity	2500pcs
Direction of feed	E2 (The direction is the 1pin of product is at the upper left when you hold reel on the left hand and you pull out the tape on the right hand)

Reel

1pin

Direction of feed

*Order quantity needs to be multiple of the minimum quantity.

Physical Dimension Tape and Reel Information – continued

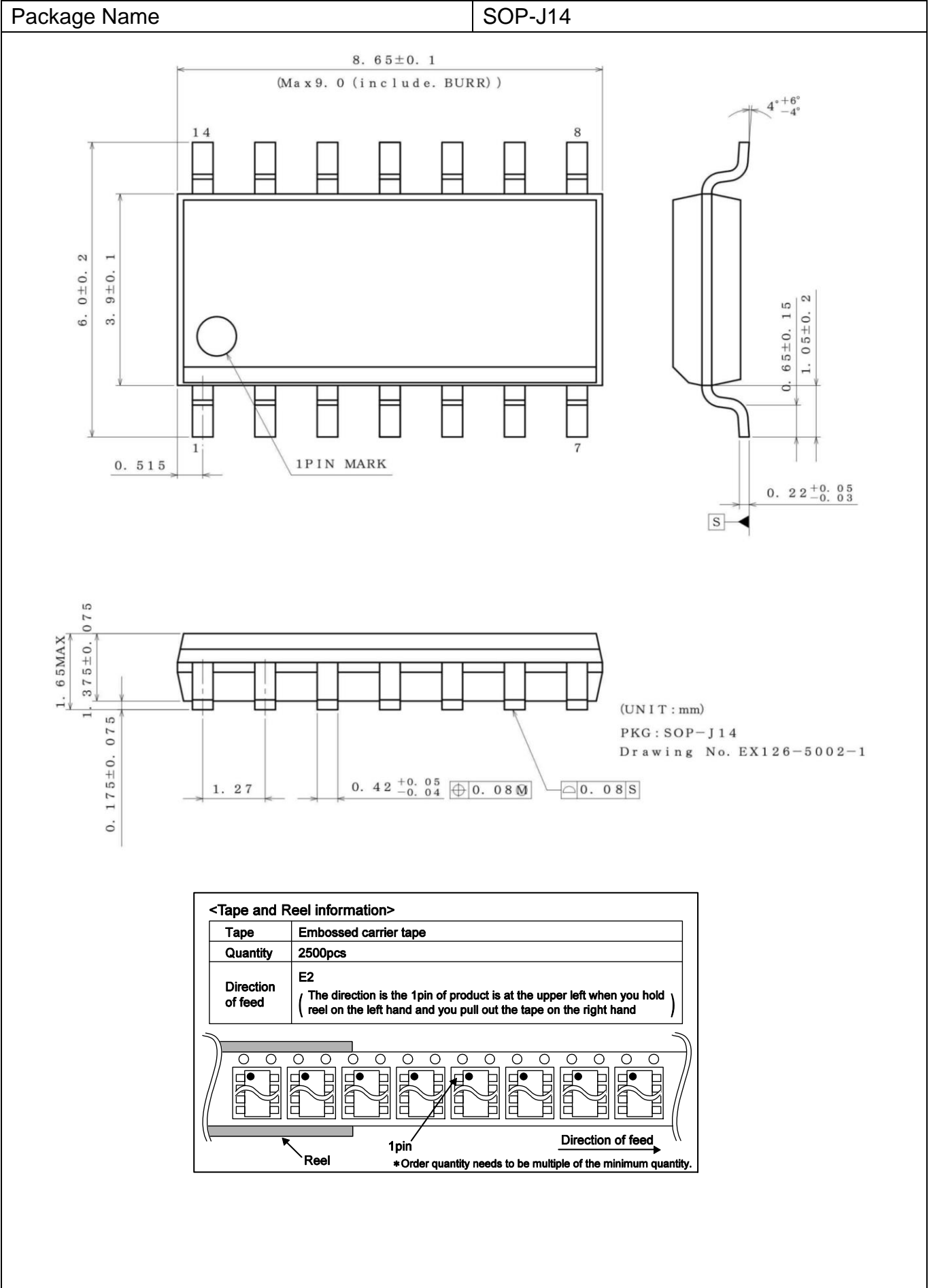

Marking Diagram

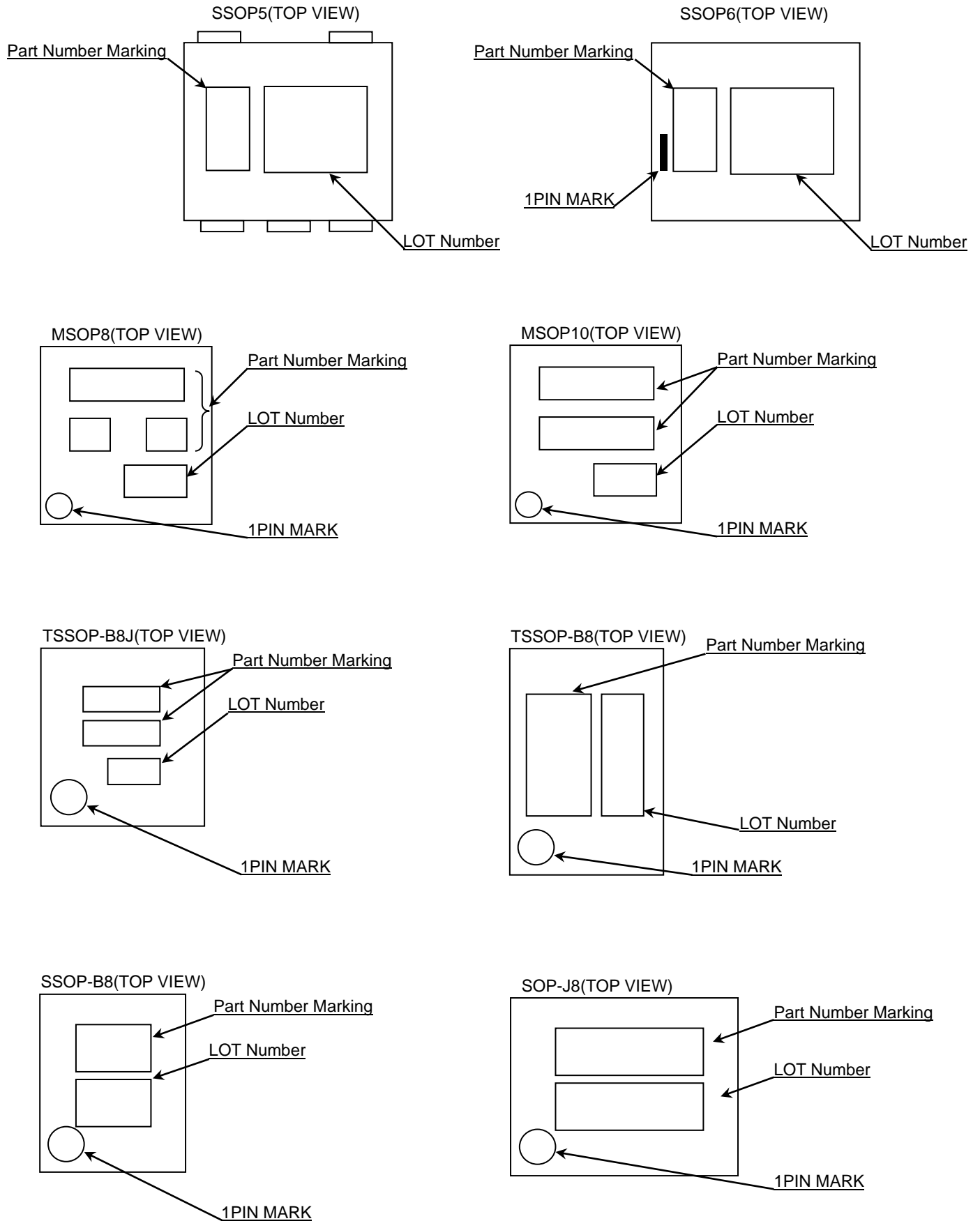

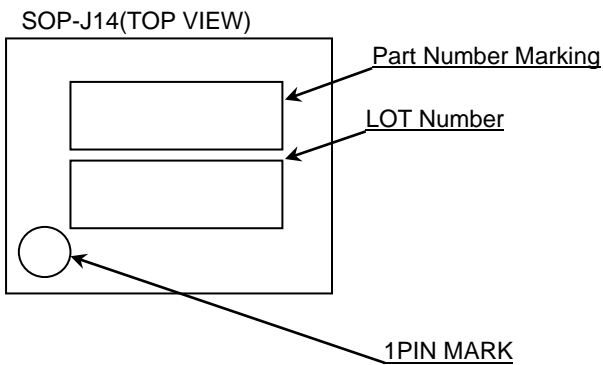
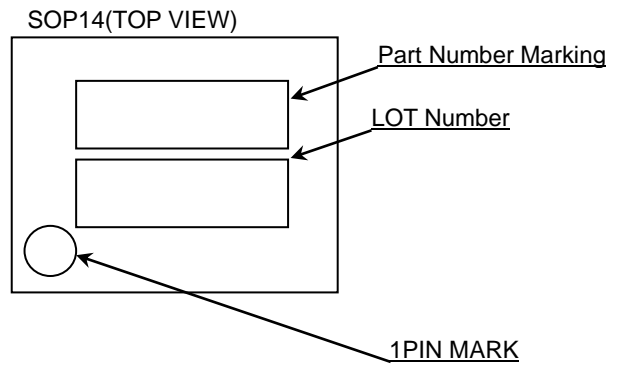
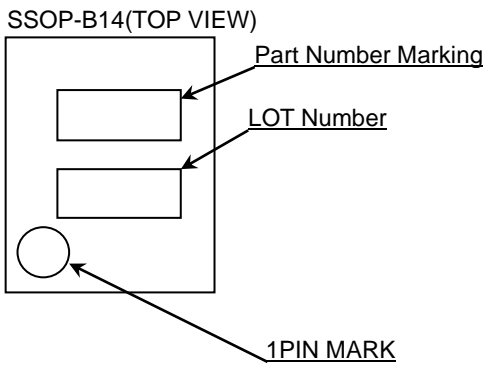
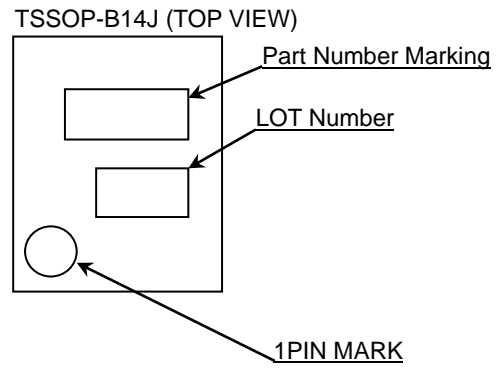
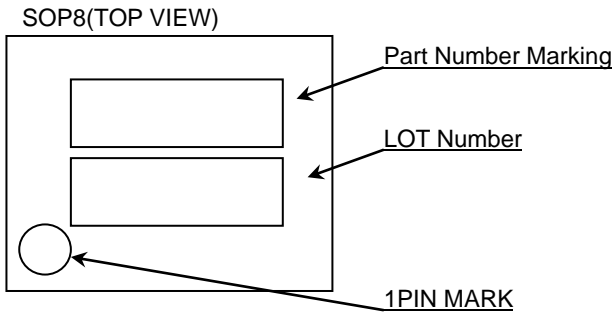

Product Name		Package Type	Marking
LMR981	G	SSOP6	BE
LMR931	G	SSOP5	L4
LMR932	F	SOP8	L932
	FJ	SOP-J8	R932
	FV	SSOP-B8	R932
	FVT	TSSOP-B8	R932
	FVM	MSOP8	R932
	FVJ	TSSOP-B8J	R932
LMR982	FVM	MSOP10	L982
LMR934	F	SOP14	R934
	FJ	SOP-J14	R934
	FV	SSOP-B14	R934
	FVJ	TSSOP-B14J	R934

Land Pattern Data

All dimensions in mm

PKG	Land pitch e	Land space MIE	Land length $\geq \ell 2$	Land width b2
SSOP5 SSOP6	0.95	2.4	1.0	0.6
SOP8 SOP14	1.27	4.60	1.10	0.76
MSOP10	0.50	2.62	0.99	0.25
SOP-J8 SOP-J14	1.27	3.90	1.35	0.76
SSOP-B8 TSSOP-B8 SSOP-B14	0.65	4.60	1.20	0.35
MSOP8	0.65	2.62	0.99	0.35
TSSOP-B8J TSSOP-B14J	0.65	3.20	1.15	0.35

SOP8, SOP-J8, SOP14, SOP-J14, SSOP-B8, SSOP-B14, MSOP8, MSOP10, TSSOP-B8, TSSOP-B8J, TSSOP-B14J

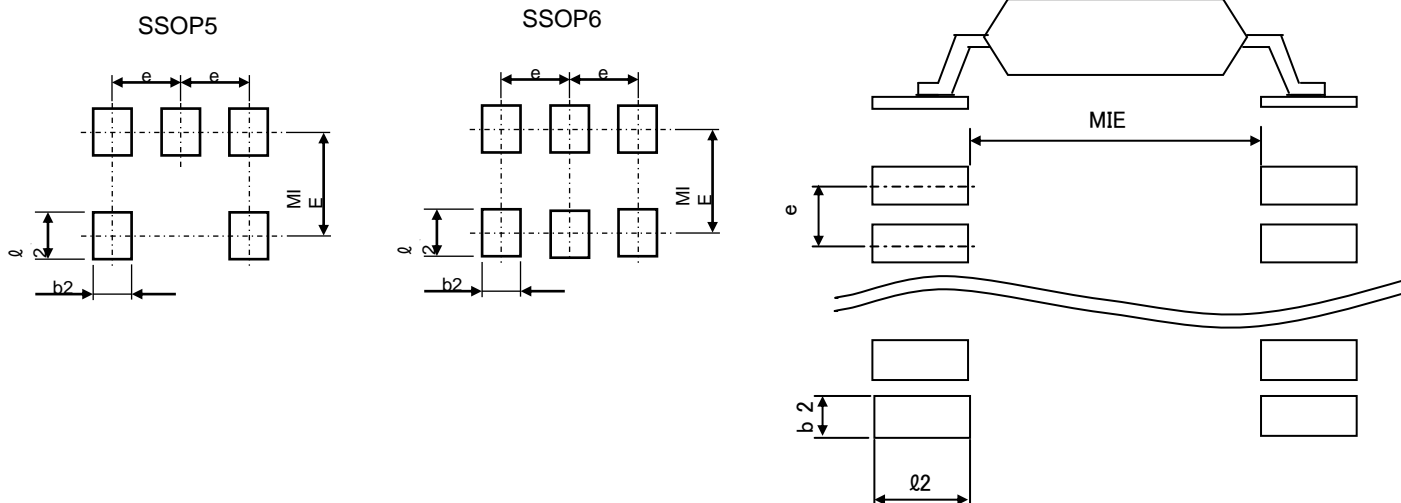

Revision History

Date	Revision	Changes
28.Dec.2012	001	New Release
25.Jan.2013	002	LMR982FVM inserted.
17.Jun.2013	003	Marking Diagram SSOP6 1PIN MARK added.
30.Sep.2013	004	Added LMR932xxx and LMR934xxx
20.Feb.2014	005	Correction of description gap of calculation(Page.37)
24.Mar.2021	006	Correction of the comparison table of Product Name and Marking.(Page.58)

Notice

Precaution on using ROHM Products

- Our Products are designed and manufactured for application in ordinary electronic equipment (such as AV equipment, OA equipment, telecommunication equipment, home electronic appliances, amusement equipment, etc.). If you intend to use our Products in devices requiring extremely high reliability (such as medical equipment ^(Note 1), transport equipment, traffic equipment, aircraft/spacecraft, nuclear power controllers, fuel controllers, car equipment including car accessories, safety devices, etc.) and whose malfunction or failure may cause loss of human life, bodily injury or serious damage to property ("Specific Applications"), please consult with the ROHM sales representative in advance. Unless otherwise agreed in writing by ROHM in advance, ROHM shall not be in any way responsible or liable for any damages, expenses or losses incurred by you or third parties arising from the use of any ROHM's Products for Specific Applications.

(Note1) Medical Equipment Classification of the Specific Applications

JAPAN	USA	EU	CHINA
CLASS III	CLASS III	CLASS II b	CLASS III
CLASS IV		CLASS III	

- ROHM designs and manufactures its Products subject to strict quality control system. However, semiconductor products can fail or malfunction at a certain rate. Please be sure to implement, at your own responsibilities, adequate safety measures including but not limited to fail-safe design against the physical injury, damage to any property, which a failure or malfunction of our Products may cause. The following are examples of safety measures:
 - Installation of protection circuits or other protective devices to improve system safety
 - Installation of redundant circuits to reduce the impact of single or multiple circuit failure
- Our Products are designed and manufactured for use under standard conditions and not under any special or extraordinary environments or conditions, as exemplified below. Accordingly, ROHM shall not be in any way responsible or liable for any damages, expenses or losses arising from the use of any ROHM's Products under any special or extraordinary environments or conditions. If you intend to use our Products under any special or extraordinary environments or conditions (as exemplified below), your independent verification and confirmation of product performance, reliability, etc. prior to use, must be necessary:
 - Use of our Products in any types of liquid, including water, oils, chemicals, and organic solvents
 - Use of our Products outdoors or in places where the Products are exposed to direct sunlight or dust
 - Use of our Products in places where the Products are exposed to sea wind or corrosive gases, including Cl₂, H₂S, NH₃, SO₂, and NO₂
 - Use of our Products in places where the Products are exposed to static electricity or electromagnetic waves
 - Use of our Products in proximity to heat-producing components, plastic cords, or other flammable items
 - Sealing or coating our Products with resin or other coating materials
 - Use of our Products without cleaning residue of flux (Exclude cases where no-clean type fluxes is used. However, recommend sufficiently about the residue.) ; or Washing our Products by using water or water-soluble cleaning agents for cleaning residue after soldering
 - Use of the Products in places subject to dew condensation
- The Products are not subject to radiation-proof design.
- Please verify and confirm characteristics of the final or mounted products in using the Products.
- In particular, if a transient load (a large amount of load applied in a short period of time, such as pulse, is applied, confirmation of performance characteristics after on-board mounting is strongly recommended. Avoid applying power exceeding normal rated power; exceeding the power rating under steady-state loading condition may negatively affect product performance and reliability.
- De-rate Power Dissipation depending on ambient temperature. When used in sealed area, confirm that it is the use in the range that does not exceed the maximum junction temperature.
- Confirm that operation temperature is within the specified range described in the product specification.
- ROHM shall not be in any way responsible or liable for failure induced under deviant condition from what is defined in this document.

Precaution for Mounting / Circuit board design

- When a highly active halogenous (chlorine, bromine, etc.) flux is used, the residue of flux may negatively affect product performance and reliability.
- In principle, the reflow soldering method must be used on a surface-mount products, the flow soldering method must be used on a through hole mount products. If the flow soldering method is preferred on a surface-mount products, please consult with the ROHM representative in advance.

For details, please refer to ROHM Mounting specification

Precautions Regarding Application Examples and External Circuits

1. If change is made to the constant of an external circuit, please allow a sufficient margin considering variations of the characteristics of the Products and external components, including transient characteristics, as well as static characteristics.
2. You agree that application notes, reference designs, and associated data and information contained in this document are presented only as guidance for Products use. Therefore, in case you use such information, you are solely responsible for it and you must exercise your own independent verification and judgment in the use of such information contained in this document. ROHM shall not be in any way responsible or liable for any damages, expenses or losses incurred by you or third parties arising from the use of such information.

Precaution for Electrostatic

This Product is electrostatic sensitive product, which may be damaged due to electrostatic discharge. Please take proper caution in your manufacturing process and storage so that voltage exceeding the Products maximum rating will not be applied to Products. Please take special care under dry condition (e.g. Grounding of human body / equipment / solder iron, isolation from charged objects, setting of Ionizer, friction prevention and temperature / humidity control).

Precaution for Storage / Transportation

1. Product performance and soldered connections may deteriorate if the Products are stored in the places where:
 - [a] the Products are exposed to sea winds or corrosive gases, including Cl₂, H₂S, NH₃, SO₂, and NO₂
 - [b] the temperature or humidity exceeds those recommended by ROHM
 - [c] the Products are exposed to direct sunshine or condensation
 - [d] the Products are exposed to high Electrostatic
2. Even under ROHM recommended storage condition, solderability of products out of recommended storage time period may be degraded. It is strongly recommended to confirm solderability before using Products of which storage time is exceeding the recommended storage time period.
3. Store / transport cartons in the correct direction, which is indicated on a carton with a symbol. Otherwise bent leads may occur due to excessive stress applied when dropping of a carton.
4. Use Products within the specified time after opening a humidity barrier bag. Baking is required before using Products of which storage time is exceeding the recommended storage time period.

Precaution for Product Label

A two-dimensional barcode printed on ROHM Products label is for ROHM's internal use only.

Precaution for Disposition

When disposing Products please dispose them properly using an authorized industry waste company.

Precaution for Foreign Exchange and Foreign Trade act

Since concerned goods might be fallen under listed items of export control prescribed by Foreign exchange and Foreign trade act, please consult with ROHM in case of export.

Precaution Regarding Intellectual Property Rights

1. All information and data including but not limited to application example contained in this document is for reference only. ROHM does not warrant that foregoing information or data will not infringe any intellectual property rights or any other rights of any third party regarding such information or data.
2. ROHM shall not have any obligations where the claims, actions or demands arising from the combination of the Products with other articles such as components, circuits, systems or external equipment (including software).
3. No license, expressly or implied, is granted hereby under any intellectual property rights or other rights of ROHM or any third parties with respect to the Products or the information contained in this document. Provided, however, that ROHM will not assert its intellectual property rights or other rights against you or your customers to the extent necessary to manufacture or sell products containing the Products, subject to the terms and conditions herein.

Other Precaution



1. This document may not be reprinted or reproduced, in whole or in part, without prior written consent of ROHM.
2. The Products may not be disassembled, converted, modified, reproduced or otherwise changed without prior written consent of ROHM.
3. In no event shall you use in any way whatsoever the Products and the related technical information contained in the Products or this document for any military purposes, including but not limited to, the development of mass-destruction weapons.
4. The proper names of companies or products described in this document are trademarks or registered trademarks of ROHM, its affiliated companies or third parties.

General Precaution



1. Before you use our Products, you are requested to carefully read this document and fully understand its contents. ROHM shall not be in any way responsible or liable for failure, malfunction or accident arising from the use of any ROHM's Products against warning, caution or note contained in this document.
2. All information contained in this document is current as of the issuing date and subject to change without any prior notice. Before purchasing or using ROHM's Products, please confirm the latest information with a ROHM sales representative.
3. The information contained in this document is provided on an "as is" basis and ROHM does not warrant that all information contained in this document is accurate and/or error-free. ROHM shall not be in any way responsible or liable for any damages, expenses or losses incurred by you or third parties resulting from inaccuracy or errors of or concerning such information.

Looking for pricing, stock, or lifecycle information?

Click below to explore more details on WIN SOURCE:

-  [View LMR934FVJ-E2 on WIN SOURCE](#)
-  [Rohm Semiconductor](#) Information

Optimize Your Supply Chain with WIN SOURCE Solutions

-  Global Sourcing Solution
-  Obsolete Management
-  Cost Control Management
-  Shortage Management
-  Alternative Solution
-  Excess Inventory Management