



**THE DATASHEET OF  
MPQ8112AGJ-AEC1-Z**





# MPQ8112/MPQ8112A

## 60V, High-Side Current-Sense Amplifier, AEC-Q100 Qualified

### DESCRIPTION

The MPQ8112 and MPQ8112A are low-cost, unipolar, high-side current-sense amplifiers. The devices operate from a 2.7V to 60V supply and typically consume a 300 $\mu$ A current. They are ideal for today's automotive systems, industrial supplies, and systems where battery/DC current monitoring is critical.

High-side current monitoring is especially useful in battery-powered systems, since it does not interfere with the ground path of the battery charger. The common mode input ranges between 0V and 60V with a 700kHz high bandwidth. That makes these devices suitable for use in inside control and short-circuit protection loops.

The MPQ8112 directly converts a differential input voltage to a voltage output with built-in internal common input resistors and a load resistor. The MPQ8112 has a 50V/V gain.

The MPQ8112A converts the differential input voltage to a current output. This current is converted back to a voltage with an external load resistor. The MPQ8112A has an adjustable gain based on the external common input resistors and load resistor.

Both the MPQ8112 and MPQ8112A are available in TSOT23-6L packages.

### MPQ8112 FAMILY VERSIONS

Part Number	Output Gain
MPQ8112	50V/V
MPQ8112A	Adjustable

### FEATURES

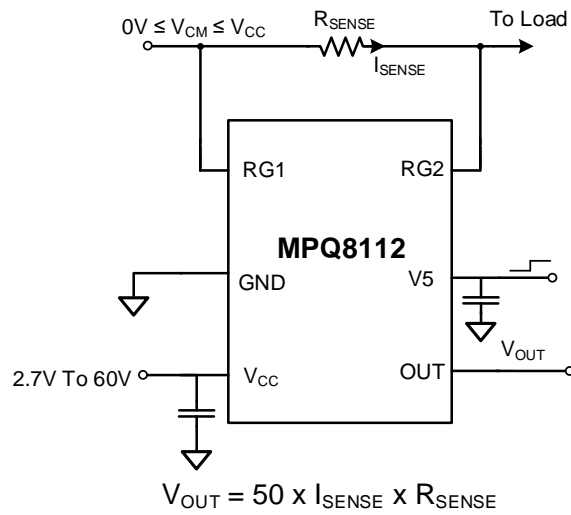
- Low-Cost, Compact Current-Sense Solution
- 700kHz Bandwidth
- 300 $\mu$ A Typical Supply Current
- 2.7V to 60V Operating Supply Voltage
- 0V to 60V Common Mode Input Range
- 0.2 $\mu$ A Typical Shutdown Current
- 300 $\mu$ V Input Offset Voltage
- Available with Fixed 50V/V Gain (MPQ8112), or Adjustable Gain (MPQ8112A)
- $\pm$ 1% Current-Sense Gain Accuracy
- High-Current Sensing Capabilities
- Available in a 6-Lead TSOT23 Package
- Available in AEC-Q100 Grade 1

### APPLICATIONS

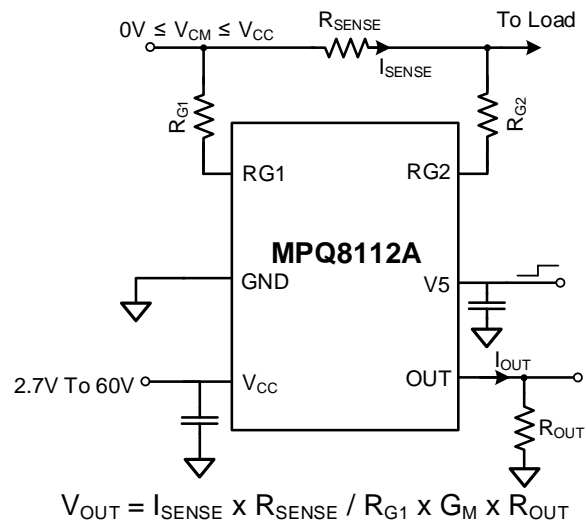
- Advanced Driver Assistance Systems (ADAS)
- Sensor Fusion Systems
- Electric Power Steering (EPS) Systems
- Electronic Stability Control (ESC) Systems
- Brake Systems
- Battery-Operated Systems
- Energy Management Systems

All MPS parts are lead-free, halogen-free, and adhere to the RoHS directive. For MPS green status, please visit the MPS website under Quality Assurance. "MPS", the MPS logo, and "Simple, Easy Solutions" are trademarks of Monolithic Power Systems, Inc. or its subsidiaries.

## TYPICAL APPLICATIONS



**Figure 1: MPQ8112 (Voltage Output)**



**Figure 2: MPQ8112A (Current Output)**

### ORDERING INFORMATION

Part Number*	Package	Top/Bottom Markings	MSL Rating**
MPQ8112GJ-AEC1	TSOT23-6L	See Below	1
MPQ8112AGJ-AEC1	TSOT23-6L	See Below	

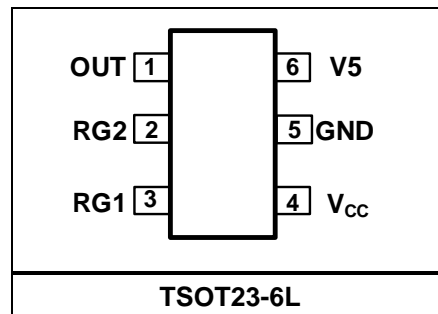
\* For Tape & Reel, add suffix -Z (e.g. MPQ8112GJ-AEC1-Z).

\*\* Moisture Sensitivity Level Rating

### TOP MARKING

Part Number	Top Marking	Bottom Marking	Definitions
MPQ8112GJ-AEC1	AXDY	CLLL	AXD: Product code Y: Year code C: Suffix LLL: Lot number
MPQ8112AGJ-AEC1	BMLY	LLLL	BML: Product code Y: Year code LLLL: Lot number

### PACKAGE REFERENCE



## PIN FUNCTIONS

Pin #	Name	Description
1	OUT	<b>Output.</b> The MPQ8112 does not require an external resistor, so the OUT pin can be left floating. For the MPQ8112A, connect an external resistor to OUT to set the gain.
2	RG2	<b>Negative gain resistor.</b> For the MPQ8112, connect RG2 directly to the load side of the current-sense resistor, as closely as possible. For the MPQ8112A, connect RG2 to the load side of the current-sense resistor through a gain resistor ( $R_{G2}$ ). $R_{G2}$ should be below 4k $\Omega$ to obtain high current-sense accuracy. It is recommended for $R_{G2}$ and $R_{G1}$ to equal 1k $\Omega$ .
3	RG1	<b>Positive gain resistor.</b> For the MPQ8112, connect RG1 directly to the power side of the current-sense resistor, as closely as possible. For the MPQ8112A, connect RG1 to the power side of the current-sense resistor through a gain resistor ( $R_{G1}$ ). $R_{G1}$ should be below 4k $\Omega$ to obtain the high current-sense accuracy. It is recommended for $R_{G1}$ to equal 1k $\Omega$ .
4	V <sub>CC</sub>	<b>Power input.</b> Place a bypass capacitor between V <sub>CC</sub> and GND, as close as possible. A 0.1 $\mu$ F to 1 $\mu$ F low-ESR ceramic capacitor is recommended.
5	GND	<b>Ground.</b>
6	V5	<b>Power supply for internal trim and control block.</b> Pull V5 above its 2V upper threshold to enable the part. Pull V5 below its 1.9V lower threshold to disable the part. The power source connected to V5 must be able to output a current above 1mA. Place a bypass capacitor between V5 and GND. A 10nF to 100nF low-ESR ceramic capacitor is recommended.

### ABSOLUTE MAXIMUM RATINGS <sup>(1)</sup>

V <sub>CC</sub> to GND	-0.3V to +62V
RG1, RG2 to GND	-0.3V to V <sub>CC</sub>
V <sub>CC</sub> to RG1, RG2	-0.3V to +62V
OUT to GND	-0.3V to +22V (MPQ8112)
OUT to GND	-0.3V to V <sub>CC</sub> (MPQ8112A)
Differential input voltage (V <sub>RG1</sub> - V <sub>RG2</sub> )	±400mV
V5 to GND	-0.3V to +6V
Max junction temperature	150°C
Storage temperature	-65°C to +150°C
Continuous power dissipation (T <sub>A</sub> = 25°C) <sup>(2)</sup>	
TSOT23-6L	0.57W

### ESD Ratings <sup>(3)</sup>

Human body model (HBM)	±2kV
Charged device model (CDM)	±750V

### Recommended Operating Conditions

V <sub>CC</sub> to GND	2.7V to 60V
RG1, RG2 to GND	0V to V <sub>CC</sub>
V <sub>CC</sub> to RG1, RG2	0V to 60V
OUT to GND	0V to 20V (MPQ8112)
OUT to GND	0V to V <sub>CC</sub> - 0.7V (MPQ8112A)
Operating junction temp (T <sub>J</sub> )	
	-40°C to +125°C <sup>(4)</sup>

### Thermal Resistance <sup>(5)</sup> $\theta_{JA}$ $\theta_{JC}$

TSOT23-6L	220	110	°C/W
-----------	-----	-----	------

#### Notes:

- Exceeding these ratings may damage the device.
- The maximum allowable power dissipation is a function of the maximum junction temperature, T<sub>J</sub> (MAX), the junction-to-ambient thermal resistance,  $\theta_{JA}$ , and the ambient temperature, T<sub>A</sub>. The maximum allowable continuous power dissipation at any ambient temperature is calculated by P<sub>D</sub> (MAX) = (T<sub>J</sub> (MAX) - T<sub>A</sub>) /  $\theta_{JA}$ . Exceeding the maximum allowable power dissipation will cause excessive die temperature, and the regulator will go into thermal shutdown. Internal thermal shutdown circuitry protects the device from permanent damage.
- These devices are ESD-sensitive. It is recommended to handle them with precaution.
- It is possible to operate the devices at junction temperatures above 125°C. Contact an MPS FAE for details.
- The value of  $\theta_{JA}$  given in this table is only valid for comparison with other packages and cannot be used for design purposes. These values were calculated in accordance with JESD51-7, and simulated on a specified JEDEC board. They do not represent the performance obtained in an actual application.

## ELECTRICAL CHARACTERISTICS

$V_{CC} = 12V$ ,  $V_{RG1} = 12V$ ,  $T_A = -40^{\circ}C$  to  $+125^{\circ}C$ , typical values at  $T_J = 25^{\circ}C$ .  $R_{G1} = R_{G2} = 0\Omega$ , and  $R_{OUT}$  not used for the MPQ8112.  $R_{G1} = R_{G2} = 1k\Omega$ , and  $R_{OUT} = 10k\Omega$  for the MPQ8112A. All unless otherwise noted.

Parameter	Symbol	Conditions	Min	Typ	Max	Units
Supply voltage	$V_{CC}$		2.7		60	V
Common mode input voltage	$V_{CM}$		0		$V_{CC}$	V
V5 supply voltage	$V_5$		2.7		5.5	V
Supply current	$I_{CC} + I_{V5}$	$V_{SENSE} = 0$ , $V_{CC} = 60V$ , $V_5 = 5V$		300	360	$\mu A$
Common mode input rejection <sup>(6)</sup>	CMR	$V_{SENSE} = 100mV$ , $V_{CC} = 60V$ , $V_{CM1} = 60V$ , $V_{CM2} = 22V$	65	90		dB
Full-scale sense voltage	$V_{SENSE}$	$V_{SENSE} = V_{RG1} - V_{RG2}$			200	mV
Input offset voltage <sup>(7)</sup>	$V_{OS}$	$V_{CM} = 12V$ , $V_{SENSE1} = 100mV$ , $V_{SENSE2} = 20mV$		0.3	1	mV
Input bias current	$I_{RG1}$ , $I_{RG2}$	$V_{CM} = 12V$		0.25	1	$\mu A$
Current-sense gain	$G_M$	$T_J = 25^{\circ}C$	4.95	5	5.05	A/A
		$T_J = -40^{\circ}C$ to $+125^{\circ}C$	4.9	5	5.1	
Output voltage gain	$A_V$	MPQ8112, $V_{SENSE} = 100mV$ , $V_{CM} = 12V$ , $T_J = 25^{\circ}C$	49.5	50	50.5	V/V
		MPQ8112, $V_{SENSE} = 100mV$ , $V_{CM} = 12V$ , $T_J = -40^{\circ}C$ to $+125^{\circ}C$	49	50	51	
Bandwidth <sup>(8)</sup>	BW	$C_{OUT} = 5pF$		700		kHz
Power supply rejection ratio <sup>(9)</sup>	PSRR	$V_{CC1} = 60V$ , $V_{CC2} = 2.7V$ , $V_{SENSE} = 24mV$	70	80		dB
V5 upper threshold voltage	$V_{TH\_UPPER}$		1.3	2	2.5	V
V5 lower threshold voltage	$V_{TH\_LOWER}$		1.2	1.9	2.4	V
V5 shutdown supply current	$I_{CC(SHDN)}$	$V_5 = 1V$		0.2	2	$\mu A$
Output respond time <sup>(8)</sup>		$R_{G1} = R_{G2} = 1k\Omega$ , $R_{OUT} = 10k\Omega$ , $V_{SENSE} = 5mV$ to $100mV$ , $V_{OUT}$ from 10% to 90%		500		ns
		$R_{G1} = R_{G2} = 1k\Omega$ , $R_{OUT} = 10k\Omega$ , $V_{SENSE} = 100mV$ to $5mV$ , $V_{OUT}$ from 10% to 90%		500		

### Notes:

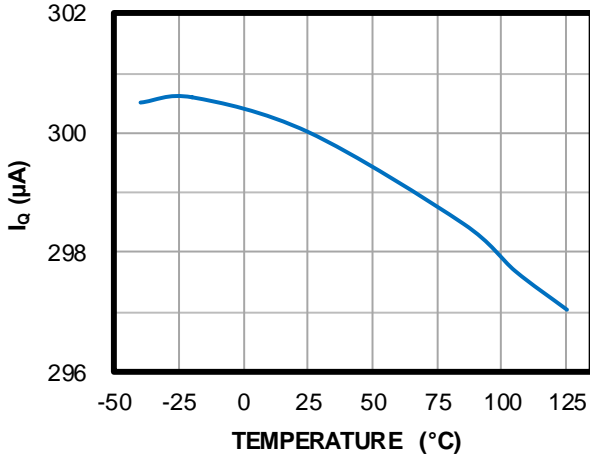
- 6)  $CMR = 20 \times \log[(V_{CM1} - V_{CM2}) / (V_{OUT1} - V_{OUT2})]$ .  $V_{OUT1}$  is the output voltage at  $V_{CM1}$ , and  $V_{OUT2}$  is the output voltage at  $V_{CM2}$ .
- 7)  $V_{OS} = V_{SENSE1} - V_{OUT1} / [(V_{OUT1} - V_{OUT2}) / (V_{SENSE1} - V_{SENSE2})]$ .  $V_{OUT1}$  is the output voltage at  $V_{SENSE1}$ , and  $V_{OUT2}$  is the output voltage at  $V_{SENSE2}$ .
- 8) Not tested in production. Guaranteed by design and characterization.
- 9)  $PSRR = 20 \times \log[(V_{CC1} - V_{CC2}) / (V_{OUT1} - V_{OUT2})]$ .  $V_{OUT1}$  is the output voltage at  $V_{CC1}$ , and  $V_{OUT2}$  is the output voltage at  $V_{CC2}$ .

## TYPICAL CHARACTERISTICS

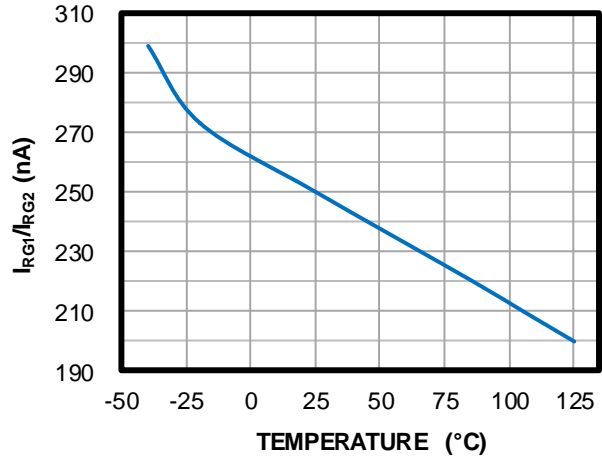
$V_{CC} = V_{RG1} = 12V$ ,  $V_5 = 5V$ ,  $T_J = -40^{\circ}C$  to  $+125^{\circ}C$ , unless otherwise noted.

**Supply Current vs. Temperature**

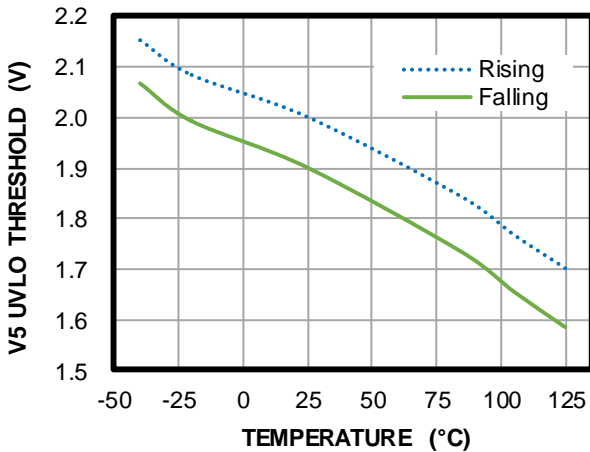
$I_Q = I_{CC} + I_{V5}$



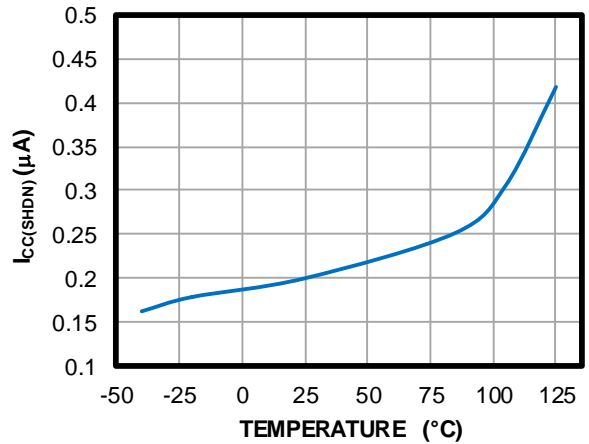
**Input Bias Current vs. Temperature**



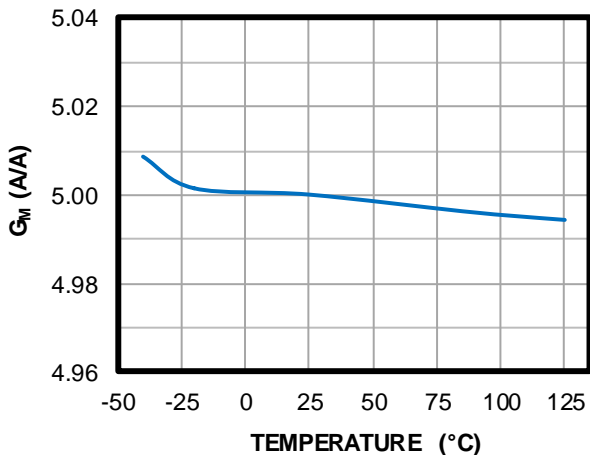
**V5 UVLO Threshold vs. Temperature**



**V5 Shutdown Supply Current vs. Temperature**

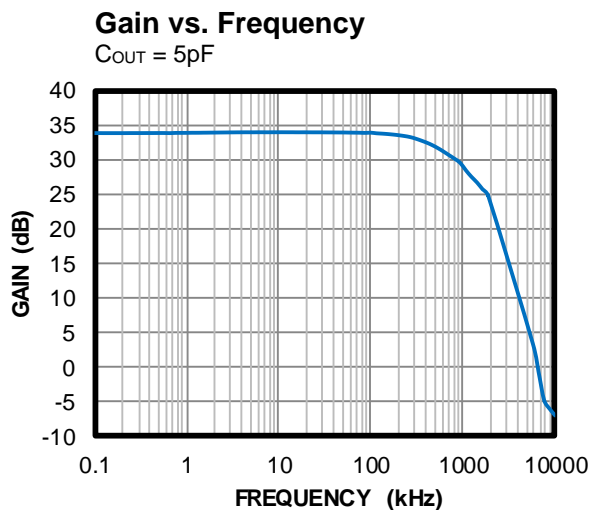
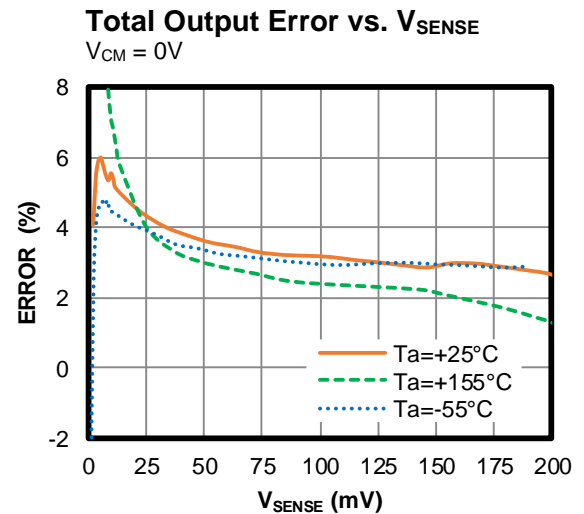
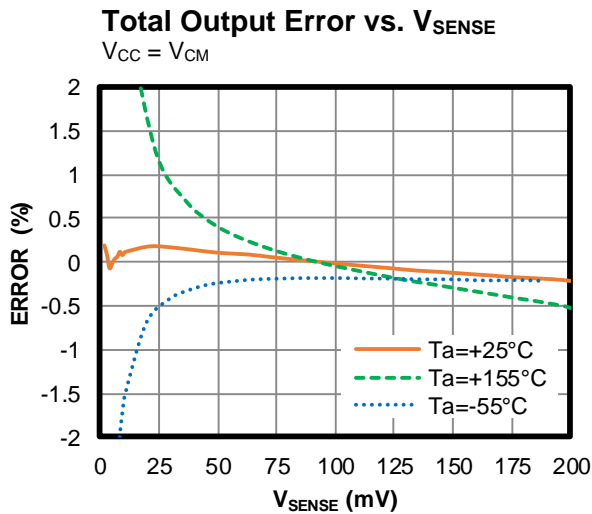
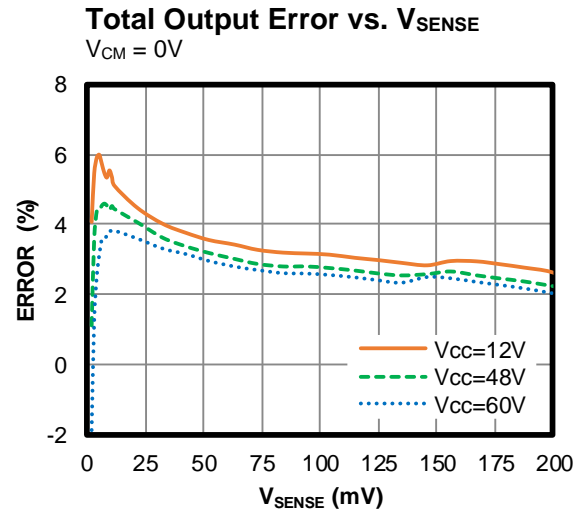
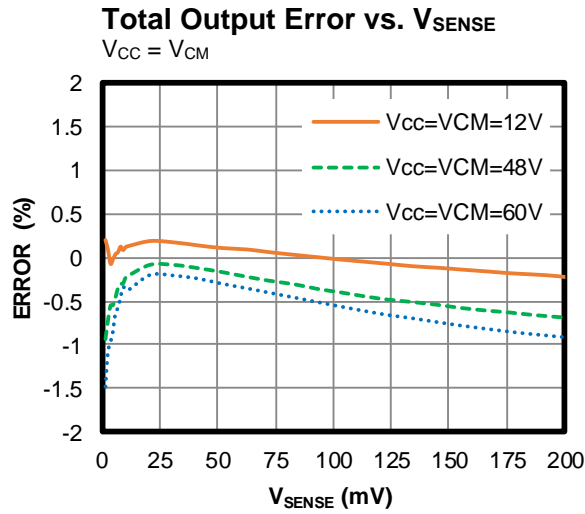


**Current-Sense Gain vs. Temperature**



**TYPICAL PERFORMANCE CHARACTERISTIC (continued)**

$V_{CC} = 12V$ ,  $V_{RG1} = 12V$ ,  $V_5 = 5V$ ,  $T_A = 25^\circ C$ .  $R_{G1} = R_{G2} = 0\Omega$ , and  $R_{OUT}$  not used for the MPQ8112.  
 $R_{G1} = R_{G2} = 1k\Omega$ , and  $R_{OUT} = 10k\Omega$  for the MPQ8112A. All unless otherwise noted.

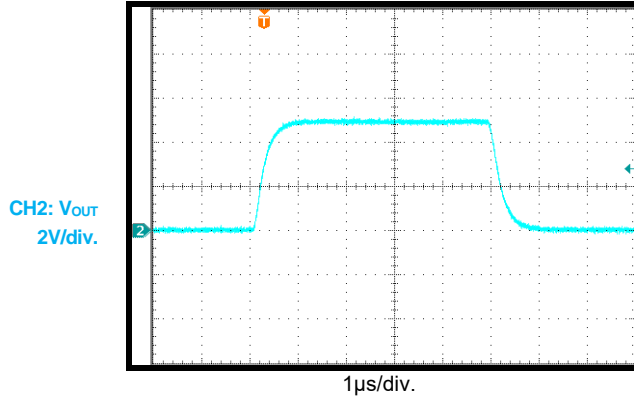


### TYPICAL PERFORMANCE CHARACTERISTICS

$V_{CC} = 12V$ ,  $V_{RG1} = 12V$ ,  $V_5 = 5V$ ,  $T_A = 25^\circ C$ .  $R_{G1} = R_{G2} = 0\Omega$ , and  $R_{OUT}$  not used for the MPQ8112.  $R_{G1} = R_{G2} = 1k\Omega$ , and  $R_{OUT} = 10k\Omega$  for the MPQ8112A. All unless otherwise noted.

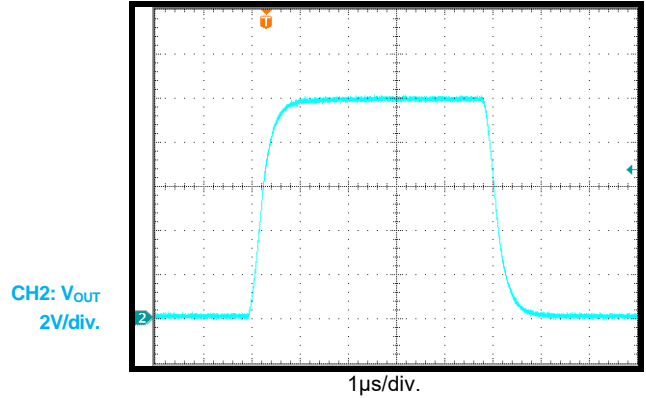
#### Transient Response

$V_{SENSE} = 0mV$  to  $100mV$



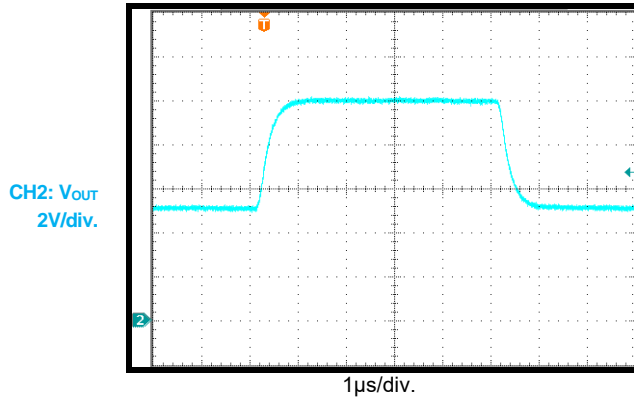
#### Transient Response

$V_{SENSE} = 0mV$  to  $200mV$



#### Transient Response

$V_{SENSE} = 100mV$  to  $200mV$



### FUNCTIONAL BLOCK DIAGRAMS

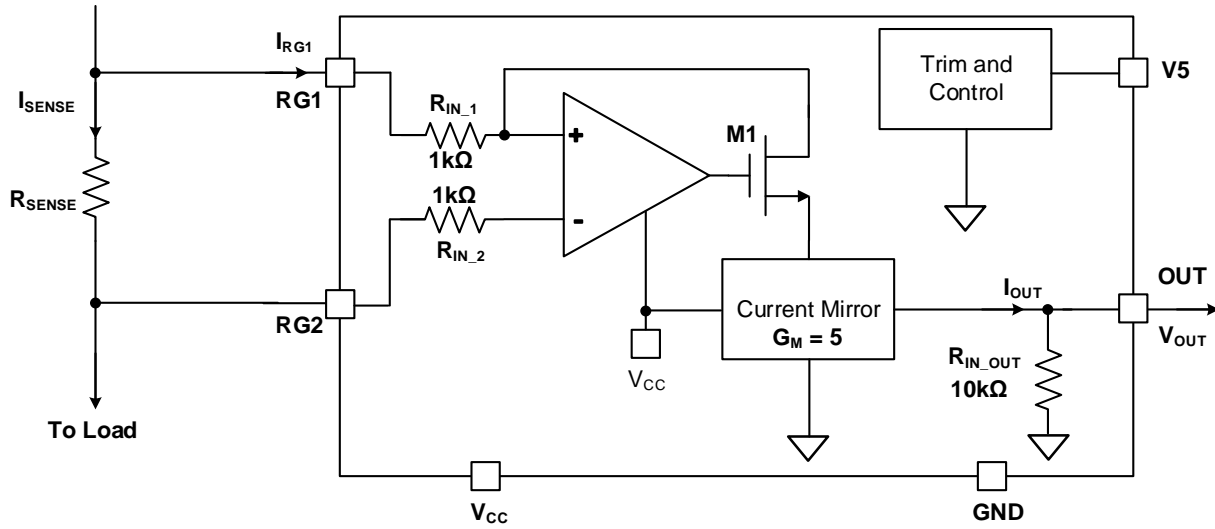


Figure 3: MPQ8112 Functional Block Diagram

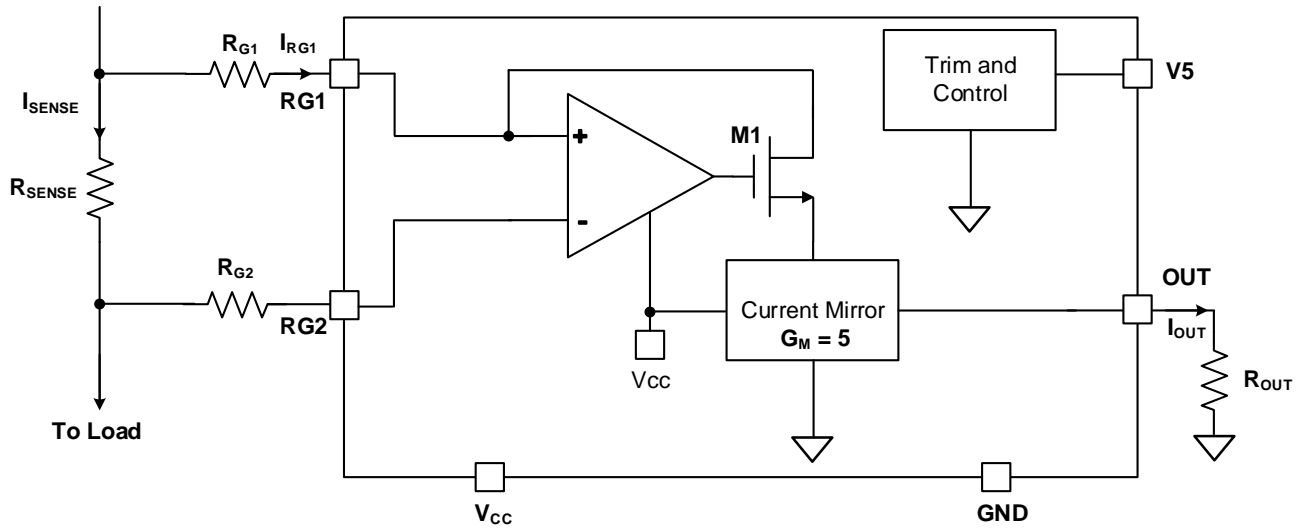


Figure 4: MPQ8112A Functional Block Diagram

## OPERATION

The MPQ8112 and MPQ8112A are high-side current-sense amplifiers with a wide 2.7V to 60V operating input voltage ( $V_{CC}$ ) range. Their common mode input voltage ( $V_{CM}$ ) is based on  $V_{CC}$ , with an operating range of  $0 \leq V_{CM} \leq V_{CC} \leq 60V$ .

The MPQ8112 directly converts a differential input voltage to a voltage output with built-in internal common input resistors and a load resistor. The MPQ8112 has a 50V/V gain.

The MPQ8112A converts the differential input voltage to a current output. This current is converted back to a voltage with an external load resistor. The MPQ8112A has an adjustable gain based on the external common input resistors and load resistor.

### Gain Setting

The sense current ( $I_{SENSE}$ ) flows through the sense resistor ( $R_{SENSE}$ ), which generates a sense voltage ( $V_{SENSE}$ ). The high-precision sense amplifier built into the MPQ8112/MPQ8112A monitors the differential voltage ( $V_{SENSE}$ ) and dynamically adjusts the gate voltage of the internal N-channel MOSFET (M1) to maintain an equal passing current ( $I_{RG1}$ ).  $I_{RG1}$  is then multiplied by a gain factor ( $G_M$ ) in the output stage current mirror, and finally flows through  $R_{OUT}$  to generate  $V_{OUT}$ .

The MPQ8112/MPQ8112A's output ( $V_{OUT}$ ) can be estimated with Equation (1):

$$V_{OUT} = I_{SENSE} \times R_{SENSE} / R_{G1} \times G_M \times R_{OUT} \quad (1)$$

Where  $G_M$  is 5A/A, and  $R_{G1}$  and  $R_{OUT}$  are external resistors for the MPQ8112A. For the MPQ8112,  $R_{G1}$  is instead  $R_{IN\_1}$ , and  $R_{OUT}$  is instead  $R_{IN\_OUT}$ . These values are 1k $\Omega$  and 10k $\Omega$ , respectively.

The total gain ( $A_V$ ) can be calculated with Equation (2):

$$A_V = V_{OUT} / V_{SENSE} = R_{OUT} / R_{G1} \times G_M \quad (2)$$

The MPQ8112A's gain is adjustable by selecting different combinations of  $R_{OUT} / R_{G1}$ . The MPQ8112's gain is fixed to 50V/V, and set by the internal resistors ( $R_{IN\_1}$  and  $R_{IN\_OUT}$ ).

### $V_{CC}$ Supply

The  $V_{CC}$  supply is the power source for the internal input stage amplifier and output stage current mirror circuitry. Use a bypass capacitor to ensure stability. Apply a 0.1 $\mu$ F to 1 $\mu$ F low-ESR ceramic capacitor between  $V_{CC}$  and GND, as close as possible. If the  $V_{CC}$  power source is noisy, additional capacitance may be required.

### Common Input Voltage

The MPQ8112/MPQ8112A's common input ranges between 0V and  $V_{CC}$ .

The minimum common input voltage is 0V. If the common input voltage is below 1.2V, an internal, dedicated compensation circuit is activated and drives the M1 drain voltage high enough to make the shunt current ( $I_{RG1}$ ) pass into the current mirror. The compensation circuit can cause the output error to rise when  $V_{CM}$  is below 1.2V ( for more information, see the Output Error vs.  $V_{SENSE}$  curves in the Typical Performance Characteristics section on page 7).

It is recommended to ensure that the common input voltage ( $V_{RG1}$ ) does not exceed  $V_{CC}$  since  $V_{RG1}$  is the positive input of the amplifier, which is powered by  $V_{CC}$ .

### V5 Supply

V5 supplies the internal control block. It also supplies the compensation circuit when the common input voltage ( $V_{RG1} / V_{RG2}$ ) is low.

V5 can act like a digital control pin that turns the current-sense amplifier on and off. If V5 is pulled below its 1.9V lower threshold voltage, the chip shuts down. If V5 is pulled above its 2V upper threshold voltage, the part turns on.

In addition, if the common input voltage drops below 1.2V, the compensation circuit is activated and drives the M1 drain voltage high enough to make the shunt current ( $I_{RG1}$ ) pass into the current mirror. The compensation circuit consumes 0.1mA to 1mA of current when it starts to work. Therefore, V5 requires a low-impedance power source and a 10nF to 100nF ceramic bypass capacitor.

## APPLICATION INFORMATION

### Setting the Output Voltage

The output voltage and gain of the MPQ8112A can be calculated with Equation (1) and Equation (2) on page 10.

The maximum output voltage ( $V_{OUT\_MAX}$ ) is limited by the power supply ( $V_{CC}$ ) and the maximum output current ( $I_{OUT\_MAX}$ ). Calculate  $V_{OUT\_MAX}$  with Equation (3) and Equation (4), using the lower value as the threshold:

$$V_{OUT\_MAX} = V_{CC} - 0.7V \quad (3)$$

$$V_{OUT\_MAX} = R_{OUT} \times I_{OUT\_MAX} \quad (4)$$

Where  $I_{OUT\_MAX}$  is 2mA when  $V_5 = 5V$ .

$I_{OUT\_MAX}$  decreases as  $V_5$  ramps down. When  $V_5$  equals 2.7V,  $I_{OUT\_MAX}$  is approximately 1mA. It is strongly recommended to connect  $V_5$  to a 5V voltage source to achieve the widest  $V_{OUT}$  range.

For the MPQ8112, the  $V_{OUT\_MAX}$  has an additional limitation, in that the maximum voltage on the built-in output resistor ( $R_{IN\_OUT}$ ) is 20V. Compare to the values obtained by Equation (3) and Equation (4) to 20V, then use the lowest value as the MPQ8112  $V_{OUT\_MAX}$  threshold.

### Selecting the Sensing Resistor

Given a full-scale sense current, select  $R_{SENSE}$  so that  $V_{SENSE}$  does not exceed 200mV, which is the maximum voltage for accuracy measurements. To measure lower currents more accurately, use a high  $R_{SENSE}$  value. A higher value develops a higher sense voltage, which overcomes offset voltage errors on the internal current amplifier. However, high  $R_{SENSE}$  values also introduce high losses. Ultimately, the  $R_{SENSE}$  selection is a tradeoff of accuracy and losses. In most applications, choose an  $R_{SENSE}$  value that provides a full-scale  $V_{SENSE}$  voltage range between 50mV and 200mV.

In applications that monitor very high current, ensure  $R_{SENSE}$  is able to dissipate its own  $I^2R$  losses. If the resistor's power rating is exceeded, its value may drift or it may fail altogether, causing a differential voltage across the terminals in excess of the absolute maximum range (0.4V).

The MPQ8112 gives a fixed gain of 50V/V; care must be taken so that  $V_{SENSE}$  does not exceed 400mV so that  $V_{OUT}$  is out of its 20V limitation.

### Selecting Common Input Resistors and Output Resistors

The MPQ8112 has built-in common input and output resistors and a fixed 50V/V gain. It does not require external resistors.

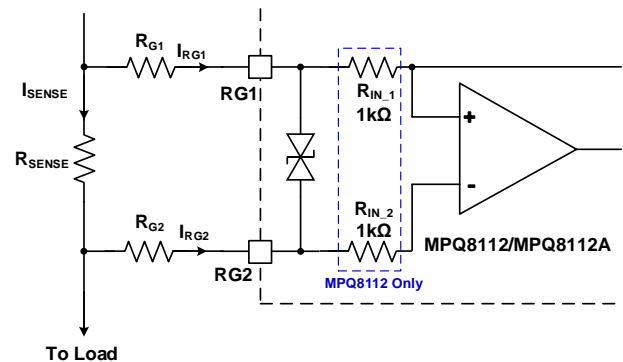
Choose the MPQ8112A's  $R_{G1}/R_{G2}$  and  $R_{OUT}$  to provide  $V_{OUT}$  with the appropriate full-scale voltage range. Select  $R_{G2}/R_{G2}$  first, and ensure that they are below 4k $\Omega$  for a high current-sense accuracy.  $R_{G1} = R_{G2} = 1k\Omega$  is recommended. Then  $R_{OUT}$  can be calculated with Equation (5):

$$R_{OUT} = V_{OUT} / (I_{SENSE} \times R_{SENSE} / R_{G1} \times G_M) \quad (5)$$

### $V_{SENSE}$ Over Maximum Rating Voltage Protection

Figure 5 shows that the MPQ8112/MPQ8112A has built-in back-to-back diodes between  $R_{G1}$  and  $R_{G2}$ . These diodes have a typical clamping voltage of  $\pm 400mV$  and a 100mA sink current capacity. In fault conditions where  $V_{SENSE}$  exceeds 400mV or drops below -400mV, the MPQ8112A avoids damage by designing the external resistors ( $R_{G1}$  and  $R_{G2}$ ) to limit the back-to-back diodes' sink current below 100mA.

The MPQ8112 also avoids damage with external resistors ( $R_{G1}$  and  $R_{G2}$ ), but its output gain and accuracy are affected by the different performance between the external and internal resistors.

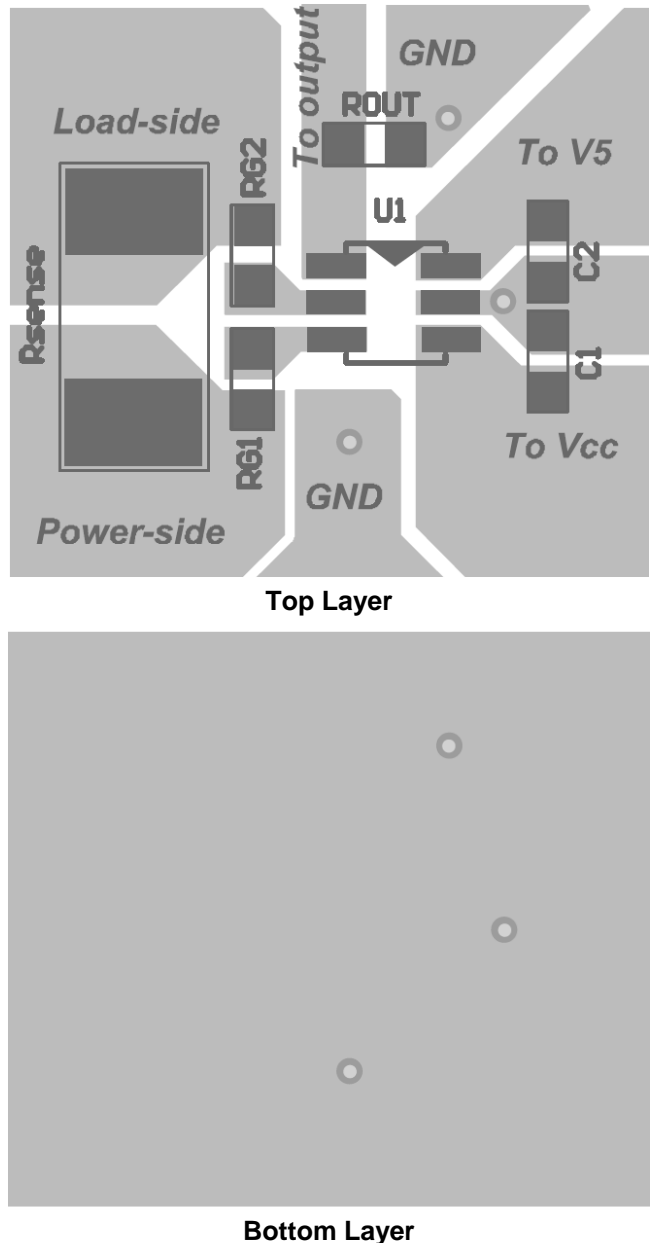


**Figure 5: Back-to-Back Diodes**

**PCB Layout Guidelines** <sup>(10)</sup>

Efficient PCB layout, especially for the sensing resistor and output resistor placement, affects measurement accuracy. For the best results, refer to Figure 6 and follow the guidelines below:

1. To minimize any resistance in series with sensing resistor trace, connect the RG1 and RG2 pins as close as possible to the sensing resistor.
2. Connect the bypass capacitors close to the device pins to decouple the power supply noise.

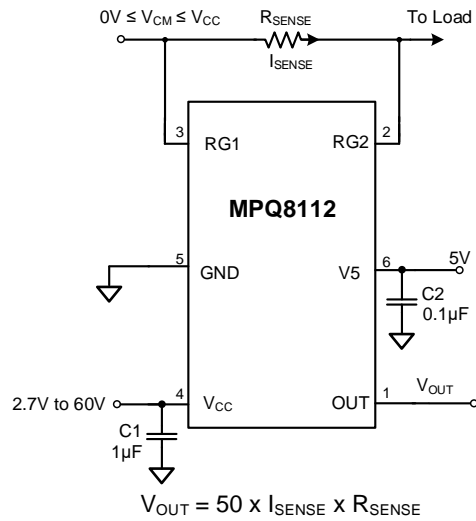
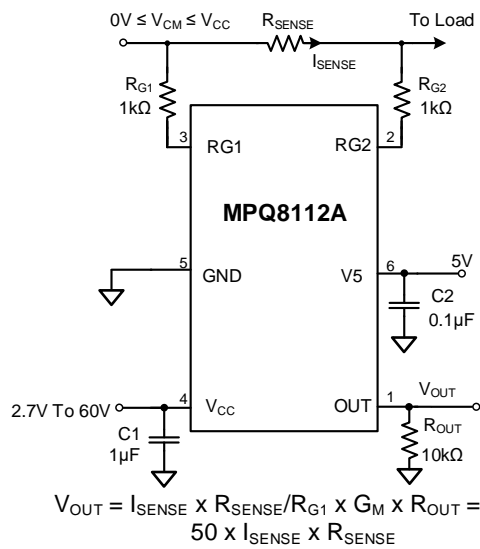


**Figure 6: Recommended PCB Layout**

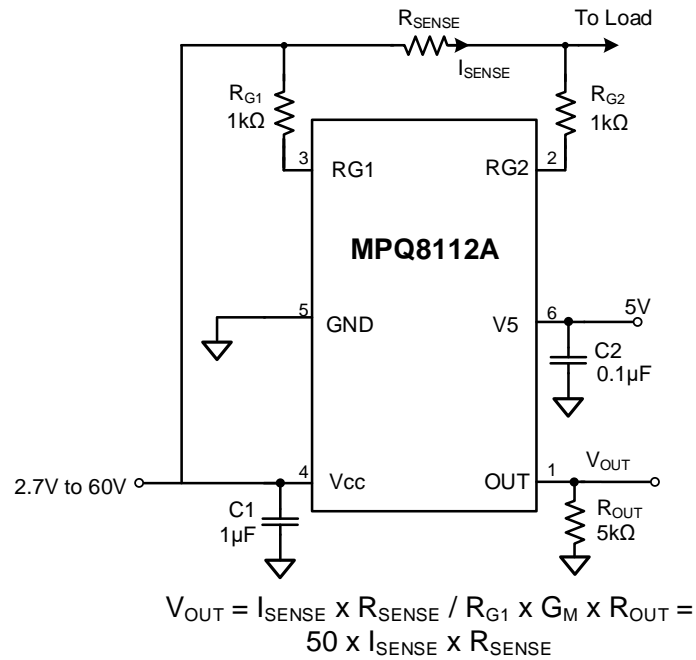
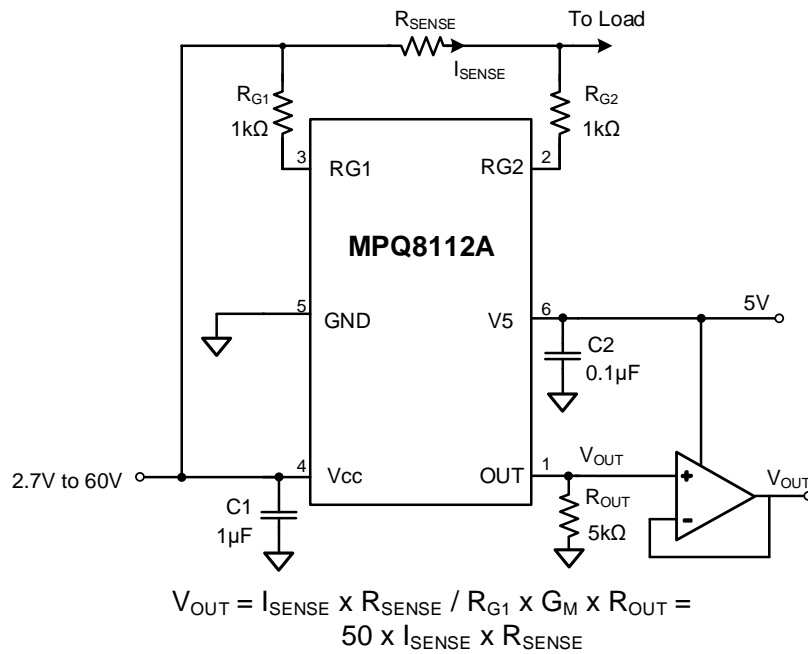
**Note:**

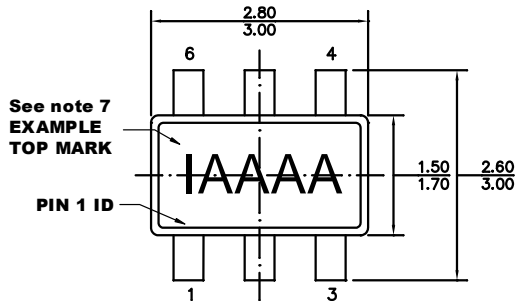
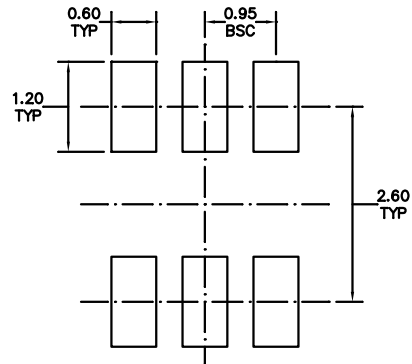
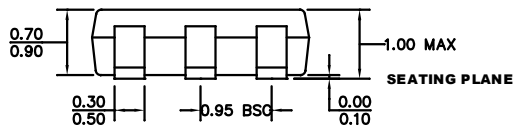
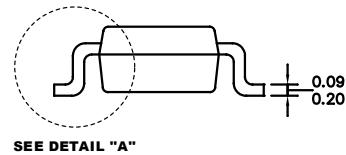
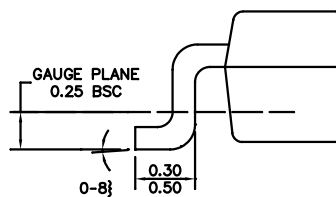
10) The recommended PCB layout is based on Figure 7.

## TYPICAL APPLICATION CIRCUITS

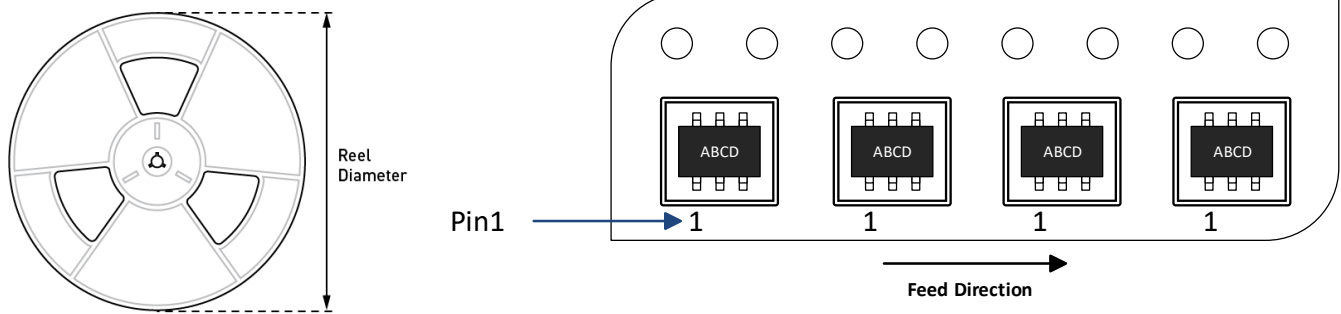

 Figure 7: MPQ8112 ( $V_{CM} \leq V_{CC}$ )

 Figure 8: MPQ8112A ( $A_V = 50V/V$  with  $V_{CM} \leq V_{CC}$ )

## TYPICAL APPLICATION CIRCUITS (continued)


 Figure 9: MPQ8112A ( $A_v = 25V/V$  with  $V_{CM} = V_{CC}$ )

 Figure 10: MPQ8112A ( $A_v = 25V/V$  with Buffer to Limit  $V_{OUT\_MAX} < V5$ )

**PACKAGE INFORMATION**
**TSOT23-6L**

**TOP VIEW**

**RECOMMENDED LAND PATTERN**

**FRONT VIEW**

**SIDE VIEW**

**DETAIL "A"**
**NOTE:**

- 1) ALL DIMENSIONS ARE IN MILLIMETERS.
- 2) PACKAGE LENGTH DOES NOT INCLUDE MOLD FLASH, PROTRUSION, OR GATE BURR.
- 3) PACKAGE WIDTH DOES NOT INCLUDE INTERLEAD FLASH OR PROTRUSION.
- 4) LEAD COPLANARITY (BOTTOM OF LEADS AFTER FORMING) SHALL BE 0.10 MILLIMETERS MAX.
- 5) DRAWING CONFORMS TO JEDEC MO-193, VARIATION AB.
- 6) DRAWING IS NOT TO SCALE.
- 7) PIN 1 IS THE LOWER-LEFT PIN WHEN READING THE TOP MARK FROM LEFT TO RIGHT (SEE EXAMPLE TOP MARK).

**CARRIER INFORMATION**


Part Number	Package Description	Quantity/ Reel	Quantity/ Tube	Quantity/ Tray	Reel Diameter	Carrier Tape Width	Carrier Tape Pitch
MPQ8112GJ-AEC1-Z	TSOT23-6L	3000	N/A	N/A	7in	8mm	4mm
MPQ8112AGJ-AEC1-Z							

## Revision History

Revision #	Revision Date	Description	Pages Updated
1.0	7/7/2020	Initial Release	-

**Notice:** The information in this document is subject to change without notice. Users should warrant and guarantee that third-party Intellectual Property rights are not infringed upon when integrating MPS products into any application. MPS will not assume any legal responsibility for any said applications.

# Mouser Electronics

Authorized Distributor



Click to View Pricing, Inventory, Delivery & Lifecycle Information:

[Monolithic Power Systems \(MPS\):](#)

[MPQ8112AGJ-AEC1-P](#) [MPQ8112AGJ-AEC1-Z](#)

## Looking for pricing, stock, or lifecycle information?

Click below to explore more details on WIN SOURCE:

-  [View MPQ8112AGJ-AEC1-Z on WIN SOURCE](#)
-  [Monolithic Power Systems Inc. Information](#)

## Optimize Your Supply Chain with WIN SOURCE Solutions

-  Global Sourcing Solution
-  Obsolete Management
-  Cost Control Management
-  Shortage Management
-  Alternative Solution
-  Excess Inventory Management