



THE DATASHEET OF MIMX8MN5CVTIZAA



MIMX8MN6CVTIZAA MIMX8MN5CVTIZAA
MIMX8MN4CVTIZAA MIMX8MN3CVTIZAA
MIMX8MN2CVTIZAA MIMX8MN1CVTIZAA
MIMX8MN5CVPIZAA MIMX8MN3CVPIZAA
MIMX8MN1CVPIZAA

i.MX 8M Nano Applications Processor Datasheet for Industrial Products

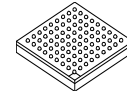

Package Information

Plastic Package
FCBGA 14 x 14 mm, 0.5 mm pitch
FCBGA 11 x 11 mm, 0.5 mm pitch

Ordering Information

See [Table 3 on page 6](#)

1 i.MX 8M Nano introduction

The i.MX 8M Nano application processor represents NXP’s latest graphics and audio experience combining state-of-the-art media-specific features with high-performance processing while optimized for lowest power consumption.

The i.MX 8M Nano family of processors features advanced implementation of a quad Arm® Cortex®-A53 core, which operates at speeds of up to 1.4 GHz. A general purpose Cortex®-M7 running up to 750 MHz core processor is for real-time and low-power processing.

The i.MX 8M Nano family of processors provides additional computing resources and peripherals:

- Advanced security modules for secure boot, cipher acceleration and DRM support
- A wide range of audio interfaces, including I2S, AC 97, TDM, and S/PDIF
- Large set of peripherals that are commonly used in consumer/industrial market, including USB and Ethernet

1. i.MX 8M Nano introduction	1
1.1. Block diagram	5
1.2. Ordering information	6
2. Modules list	8
2.1. Recommended connections for unused input/output	12
3. Electrical characteristics	14
3.1. Chip-level conditions	14
3.2. Power supplies requirements and restrictions	27
3.3. PLL electrical characteristics	33
3.4. On-chip oscillators	34
3.6. I/O AC parameters	36
3.7. Output buffer impedance parameters	37
3.8. System modules timing	39
3.9. External peripheral interface parameters	40
4. Boot mode configuration	74
4.1. Boot mode configuration pins	74
4.2. Boot device interface allocation	74
5. Package information and contact assignments	76
5.1. 14 x 14 mm package information	76
5.2. 11 x 11 mm package information	92
5.3. DDR pin function list	107
6. Revision history	110



Table 1. Features

Subsystem	Feature
Cortex®-A53 MPCore platform	Quad symmetric Cortex® -A53 processors <ul style="list-style-type: none"> • 32 KB L1 Instruction Cache • 32 KB L1 Data Cache • Media Processing Engine (MPE) with Arm® NEON™ technology supporting the Advanced Single Instruction Multiple Data architecture: • Floating Point Unit (FPU) with support of the Arm® VFPv4-D16 architecture
	Support of 64-bit Arm®v8-A architecture
	512 KB unified L2 cache
Cortex®-M7 core platform	Low power microcontroller available for customer application: <ul style="list-style-type: none"> • low power standby mode • IoT features including Weave • Manage IR or wireless remote • ML inference applications (enhanced for i.MX 8M Nano)
	Cortex® M7 CPU: <ul style="list-style-type: none"> • 256 KB tightly coupled memory (TCM)
Connectivity	One USB 2.0 OTG controllers with integrated PHY interfaces: <ul style="list-style-type: none"> • Spread spectrum clock support
	Three Ultra Secure Digital Host Controller (uSDHC) interfaces: <ul style="list-style-type: none"> • MMC 5.1 compliance with HS400 DDR signaling to support up to 400 MB/sec • SD/SDIO 3.0 compliance with 200 MHz SDR signaling to support up to 100 MB/sec • Support for SDXC (extended capacity)
	One Gigabit Ethernet controller with support for Energy Efficient Ethernet (EEE), Ethernet AVB, and IEEE 1588
	Four Universal Asynchronous Receiver/Transmitter (UART) modules
	Four I ² C modules
	Three SPI modules
On-chip memory	Boot ROM (256 KB)
	On-chip RAM (512 KB + 32 KB)
GPIO and pin multiplexing	General-purpose input/output (GPIO) modules with interrupt capability
	Input/output multiplexing controller (IOMUXC) to provide centralized pad control
Power management	Temperature sensor with programmable trip points
	Flexible power domain partitioning with internal power switches to support efficient power management

Table 1. Features (continued)

Subsystem	Feature
External memory interface	16-bit DRAM interfaces: <ul style="list-style-type: none"> • LPDDR4-3200 • DDR4-2400 • DDR3L-1600
	8-bit NAND-Flash, including support for Raw MLC/SLC devices, BCH ECC up to 62-bit, and ONFi3.2 compliance (clock rates up to 100 MHz and data rates up to 200 MB/sec)
	eMMC 5.1 Flash (3 interfaces)
	SPI NOR Flash (3 interfaces)
	QuadSPI Flash with support for XIP (for Cortex®-M7 in low-power mode) and parallel read mode of two identical FLASH devices
Multimedia	Graphic Processing Unit: <ul style="list-style-type: none"> • GC7000UL with OpenCL and Vulkan support • 2 shader • 99.8 million triangles/sec • 0.6 giga pixel/sec • 9.6 GFLOPs 32-bit/19.2 GFLOPs 16-bit • Supports OpenGL ES 1.1, 2.0, 3.0, OpenCL • Core clock frequency of 600 MHz • Shader clock frequency of 600 MHz
	LCDIF Display Controller: <ul style="list-style-type: none"> • Support up to 1080p60 display through MIPI DSI
	MIPI Interfaces: <ul style="list-style-type: none"> • 4-lane MIPI DSI interface • 4-lane MIPI CSI interface
	Audio: <ul style="list-style-type: none"> • S/PDIF input and output, including a raw capture input mode • Five external synchronous audio interface (SAI) modules supporting I2S, AC97, TDM, codec/DSP, and DSD interfaces, comprising one SAI with 4 Tx and 4 Rx lanes, two SAI with 2 Tx and 2 Rx lanes, and two SAI with 1 Tx and 1Rx lane. All ports support 49.152 MHz BCLK. • ASRC supports processing 32 audio channels, 4 context groups, 8 kHz to 384 kHz sample rate and 1/16 to 8x sample rate conversion ratio. • Pulse Density Modulation (PDM) input

Table 1. Features (continued)

Subsystem	Feature
Security	Resource Domain Controller (RDC): <ul style="list-style-type: none"> • supports 4 domains and up to 8 regions of DDR
	Arm® TrustZone® (TZ) architecture: <ul style="list-style-type: none"> • Arm® Cortex-A53 MPCore TrustZone support
	On-chip RAM (OCRAM) secure region protection using OCRAM controller
	High Assurance Boot (HAB)
	Cryptographic acceleration and assurance module (CAAM): <ul style="list-style-type: none"> • Support Widevine and PlayReady content protection • Public Key Cryptography (PKHA) with RSA and Elliptic Curve (ECC) algorithms • Real-time integrity checker (RTIC) • DRM support for RSA, AES, 3DES, DES • Side channel attack resistance • True random number generation (RNG) • Manufacturing protection support
	Secure non-volatile storage (SNVS): <ul style="list-style-type: none"> • Secure real-time clock (RTC)
	Secure JTAG controller (SJC)
System debug	Arm® CoreSight™ debug and trace technology
	Trace Port Interface Unit (TPIU) to support off-chip real-time trace
	Embedded Trace FIFO (ETF) with 4 KB internal storage to provide trace buffering
	Unified trace capability for Quad Cortex®-A53 and Cortex®-M7 CPUs
	Cross Triggering Interface (CTI)
	Support for 4-pin (JTAG) debug interface

NOTE

The actual feature set depends on the part numbers as described in [Table 3](#). Functions such as display and camera interfaces, and connectivity interfaces, may not be enabled for specific part numbers.

1.1 Block diagram

Figure 1 shows the functional modules in the i.MX 8M Nano applications processor system.

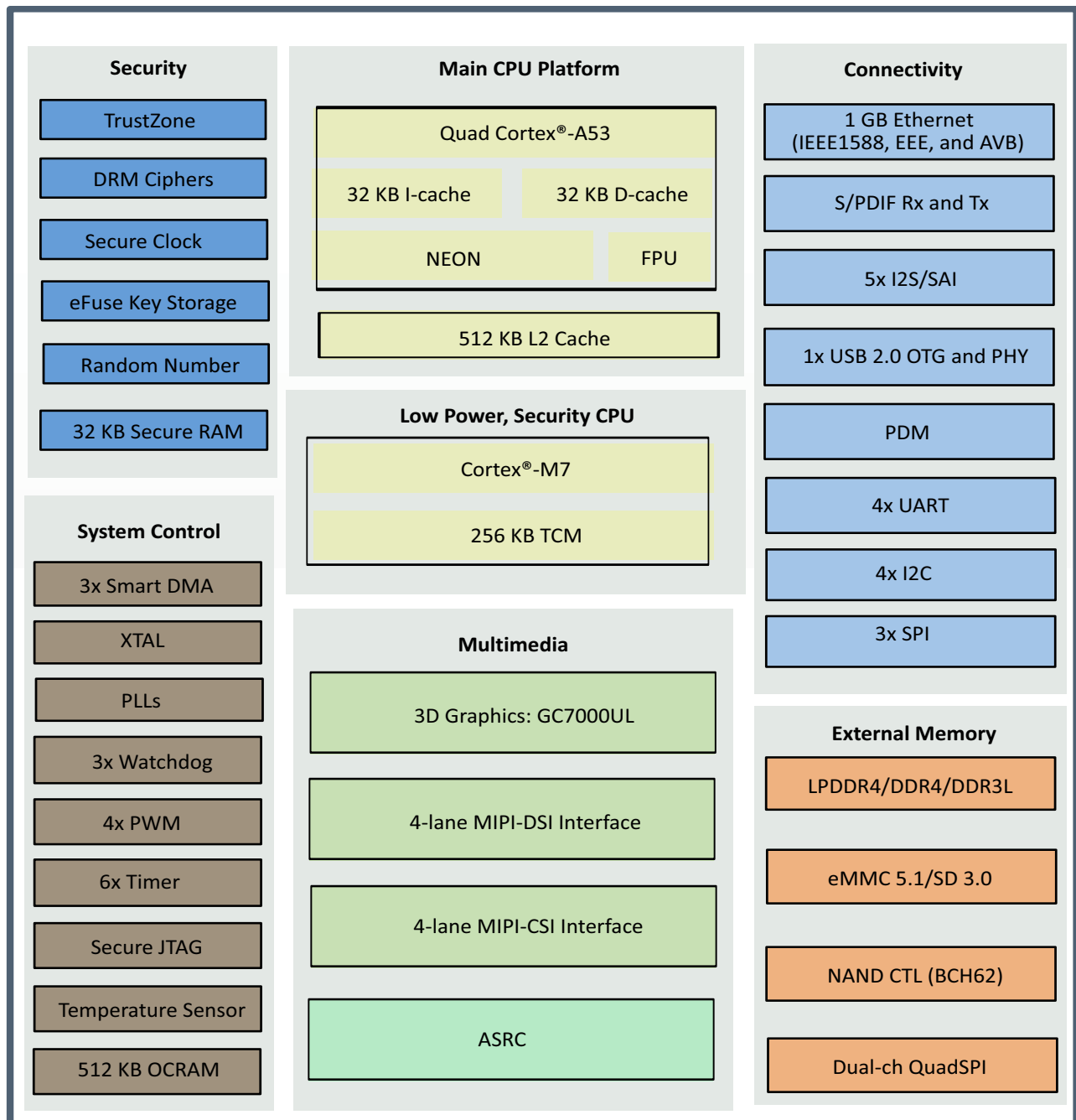

Figure 1. i.MX 8M Nano system block diagram

NOTE

Some modules shown in this block diagram are not offered on all derivatives. See [Table 2](#) for exceptions.

Table 2. Modules supported

Key Modules	6CVT	5CVT	4CVT	3CVT	2CVT	1CVT	5CVP	3CVP	1CVP
Cortex [®] A53	4x	4x	2x	2x	1x	1x	4x	2x	1x
Cortex [®] M7	1x	1x	1x	1x	1x	1x	1x	1x	1x
GPU	1x	N/A	1x	N/A	1x	N/A	N/A	N/A	N/A
MIPI DSI	1x	1x	1x	1x	1x	1x	N/A	N/A	N/A

1.2 Ordering information

[Table 3](#) shows examples of orderable sample part numbers covered by this data sheet. This table does not include all possible orderable part numbers. If your desired part number is not listed in the table, or you have questions about available parts, contact your NXP representative.

Table 3. Orderable part numbers

Part number	Sub-Family	Options	Cortex-A53 CPU speed grade	Qualification tier	Temperature T _j (°C)	Package
MIMX8MN6CVTIZAA	i.MX 8M Nano Quad	4x A53, M7, GPU, MIPI DSI	1.4 GHz	Industrial	-40 to 105	14 x 14 mm, 0.5 mm pitch
MIMX8MN5CVTIZAA	i.MX 8M Nano QuadLite	4x A53, M7, No GPU, MIPI DSI	1.4 GHz	Industrial	-40 to 105	14 x 14 mm, 0.5 mm pitch
MIMX8MN4CVTIZAA	i.MX 8M Nano Dual	2x A53, M7, GPU, MIPI DSI	1.4 GHz	Industrial	-40 to 105	14 x 14 mm, 0.5 mm pitch
MIMX8MN3CVTIZAA	i.MX 8M Nano DualLite	2x A53, M7, No GPU, MIPI DSI	1.4 GHz	Industrial	-40 to 105	14 x 14 mm, 0.5 mm pitch
MIMX8MN2CVTIZAA	i.MX 8M Nano Solo	1x A53, M7, GPU, MIPI DSI	1.4 GHz	Industrial	-40 to 105	14 x 14 mm, 0.5 mm pitch
MIMX8MN1CVTIZAA	i.MX 8M Nano SoloLite	1x A53, M7, No GPU, MIPI DSI	1.4 GHz	Industrial	-40 to 105	14 x 14 mm, 0.5 mm pitch
MIMX8MN5CVPIZAA	i.MX 8M Nano UltraLite Quad	4x A53, M7, No GPU, No MIPI DSI	1.4 GHz	Industrial	-40 to 105	11 x 11 mm, 0.5 mm pitch
MIMX8MN3CVPIZAA	i.MX 8M Nano UltraLite Dual	2x A53, M7, No GPU, No MIPI DSI	1.4 GHz	Industrial	-40 to 105	11 x 11 mm, 0.5 mm pitch
MIMX8MN1CVPIZAA	i.MX 8M Nano UltraLite Solo	1x A53, M7, No GPU, No MIPI DSI	1.4 GHz	Industrial	-40 to 105	11 x 11 mm, 0.5 mm pitch

[Figure 2](#) describes the part number nomenclature so that the users can identify the characteristics of the specific part number.

Contact an NXP representative for additional details.

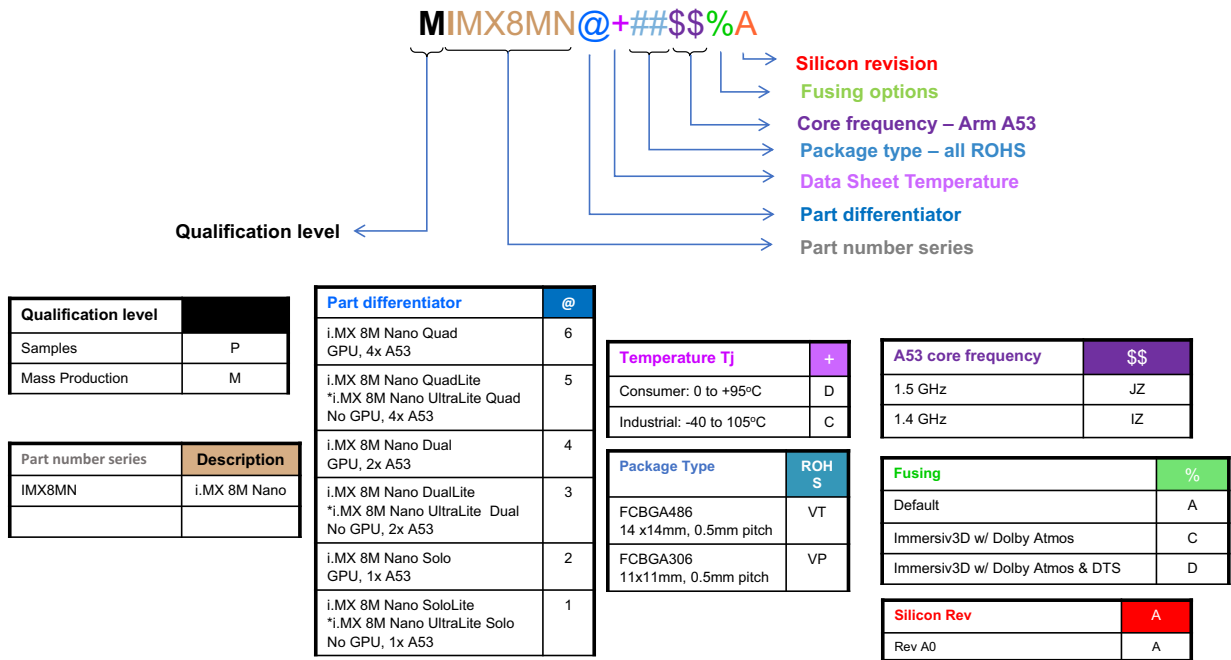

*i.MX 8M Nano UltraLite Quad/Dual/Solo (11x11 package) has no MIPI DSI

Figure 2. Part number nomenclature—i.MX 8M Nano family of processors

2 Modules list

The i.MX 8M Nano family of processors contains a variety of digital and analog modules. [Table 4](#) describes these modules in alphabetical order.

Table 4. i.MX 8M Nano modules list

Block mnemonic	Block name	Brief description
APBH-DMA	NAND Flash and BCH ECC DMA Controller	DMA controller used for GPMI2 operation.
Arm	Arm Platform	The Arm Core Platform includes a quad Cortex-A53 core and a Cortex-M7 core. The Cortex-A53 core includes associated sub-blocks, such as the Level 2 Cache Controller, Snoop Control Unit (SCU), General Interrupt Controller (GIC), private timers, watchdog, and CoreSight debug modules. The Cortex-M7 core is used as a customer microcontroller.
BCH	Binary-BCH ECC Processor	The BCH module provides up to 62-bit ECC encryption/decryption for NAND Flash controller (GPMI)
CAAM	Cryptographic accelerator and assurance module	CAAM is a cryptographic accelerator and assurance module. CAAM implements several encryption and hashing functions, a run-time integrity checker, entropy source generator, and a Pseudo Random Number Generator (PRNG). The PRNG is certifiable by the Cryptographic Algorithm Validation Program (CAVP) of the National Institute of Standards and Technology (NIST). CAAM also implements a Secure Memory mechanism. In i.MX 8M Nano processors, the secure memory provided is 32 KB.
CCM GPC SRC	Clock Control Module, General Power Controller, System Reset Controller	These modules are responsible for clock and reset distribution in the system, and also for the system power management.
CSU	Central Security Unit	The Central Security Unit (CSU) is responsible for setting comprehensive security policy within the i.MX 8M Nano platform.
CTI-0 CTI-1 CTI-2 CTI-3 CTI-4	Cross Trigger Interface	Cross Trigger Interface (CTI) allows cross-triggering based on inputs from masters attached to CTIs. The CTI module is internal to the Cortex-A53 core platform.
DAP	Debug Access Port	The DAP provides real-time access for the debugger without halting the core to access: <ul style="list-style-type: none"> • System memory and peripheral registers • All debug configuration registers The DAP also provides debugger access to JTAG scan chains.
DDRC	Double Data Rate Controller	The DDR Controller has the following features: <ul style="list-style-type: none"> • Supports 16-bit LPDDR4-3200, DDR4-2400, and DDR3L-1600 • Supports up to 8 Gbyte DDR memory space
eCSPI1 eCSPI2 eCSPI3	Configurable SPI	Full-duplex enhanced Synchronous Serial Interface, with data rate up to 52 Mbit/s. Configurable to support Master/Slave modes, four chip selects to support multiple peripherals.

Table 4. i.MX 8M Nano modules list (continued)

Block mnemonic	Block name	Brief description
ENET1	Ethernet Controller	The Ethernet Media Access Controller (MAC) is designed to support 10/100/1000 Mbps Ethernet/IEEE 802.3 networks. An external transceiver interface and transceiver function are required to complete the interface to the media. The module has dedicated hardware to support the IEEE 1588 standard. See the ENET chapter of the <i>i.MX 8M Nano Applications Processor Reference Manual (IMX8MNRM)</i> for details.
FlexSPI	FlexSPI	The FlexSPI module acts as an interface to external serial flash devices. This module contains the following features: <ul style="list-style-type: none"> • Flexible sequence engine to support various flash vendor devices • Single pad/Dual pad/Quad pad mode of operation • Single Data Rate/Double Data Rate mode of operation • Parallel Flash mode • DMA support • Memory mapped read access to connected flash devices • Multi master access with priority and flexible and configurable buffer for each master
GIC	Generic Interrupt Controller	The GIC handles all interrupts from the various subsystems and is ready for virtualization.
GPC	General Power Control Module	The GPC independently control reset and gated clock to each switched power domain when powering on/off the domain.
GPIO1 GPIO2 GPIO3 GPIO4 GPIO5	General Purpose I/O Modules	Used for general purpose input/output to external ICs. Each GPIO module supports up to 32 bits of I/O.
GPMI	General Purpose Memory Interface	The GPMI module supports up to 8x NAND devices and 62-bit ECC encryption/decryption for NAND Flash Controller (GPMI2). GPMI supports separate DMA channels for each NAND device.
GPT1 GPT2 GPT3 GPT4 GPT5 GPT6	General Purpose Timer	Each GPT is a 32-bit “free-running” or “set-and-forget” mode timer with programmable prescaler and compare and capture register. A timer counter value can be captured using an external event and can be configured to trigger a capture event on either the leading or trailing edges of an input pulse. When the timer is configured to operate in “set-and-forget” mode, it is capable of providing precise interrupts at regular intervals with minimal processor intervention. The counter has output compare logic to provide the status and interrupt at comparison. This timer can be configured to run either on an external clock or on an internal clock.
GPU3D	Graphics Processing Unit-3D	The GPU3D provides hardware acceleration for 3D graphics algorithms with sufficient processor power to run desktop quality interactive graphics applications on displays.
I2C1 I2C2 I2C3 I2C4	I ² C Interface	I ² C provides serial interface for external devices. Data rates of up to 320 kbps are supported.

Table 4. i.MX 8M Nano modules list (continued)

Block mnemonic	Block name	Brief description
IOMUXC	IOMUX Control	This module enables flexible I/O multiplexing. Each IO pad has a default as well as several alternate functions. The alternate functions are software configurable.
LCDIF	LCD interface	The LCDIF is a general purpose display controller used to drive a wide range of display devices varying in size and capability, the key feature of the display controller includes: <ul style="list-style-type: none"> • Support 8-bit/16-bit/24-bit/32-bit pixel depth • Support DOTCLK mode for MIPI-DPI interface • Support resolution up to 1920 x1200p60
MIPI CSI (four-lane)	MIPI Camera Serial Interface	This module provides one four-lane MIPI camera serial interfaces, which operates up to a maximum bit rate of 1.5 Gbps.
MIPI DSI (four-lane)	MIPI Display Serial Interface	This module provides a four-lane MIPI display serial interface operating up to a maximum bit rate of 1.5 Gbps.
OCOTP_CTRL	OTP Controller	The On-Chip OTP controller (OCOTP_CTRL) provides an interface for reading, programming, and/or overriding identification and control information stored in on-chip fuse elements. The module supports electrically programmable poly fuses (eFUSEs). The OCOTP_CTRL also provides a set of volatile software-accessible signals that can be used for software control of hardware elements, not requiring non volatility. The OCOTP_CTRL provides the primary user-visible mechanism for interfacing with on-chip fuse elements. Among the uses for the fuses are unique chip identifiers, mask revision numbers, cryptographic keys, JTAG secure mode, boot characteristics, and various control signals requiring permanent non volatility.
OCRAM	On-Chip Memory controller	The On-Chip Memory controller (OCRAM) module is designed as an interface between the system's AXI bus and the internal (on-chip) SRAM memory module. In i.MX 8M Nano processors, the OCRAM is used for controlling the 512 KB multimedia RAM through a 64-bit AXI bus.
PDM	Pulse Density Modulation	The PDM supports up to 8-channels (4 lanes).
PWM1 PWM2 PWM3 PWM4	Pulse Width Modulation	The pulse-width modulator (PWM) has a 16-bit counter and is optimized to generate sound from stored sample audio images. It can also generate tones. It uses 16-bit resolution and a 4x16 data FIFO to generate sound.
SAI2 SAI3 SAI5 SAI6 SAI7	Synchronous Audio Interface	The SAI module provides a synchronous audio interface (SAI) that supports full duplex serial interfaces with frame synchronization, such as I2S, AC97, TDM, and codec/DSP interfaces.

Table 4. i.MX 8M Nano modules list (continued)

Block mnemonic	Block name	Brief description
SDMA	Smart Direct Memory Access	<p>The SDMA is a multichannel flexible DMA engine. It helps in maximizing system performance by offloading the various cores in dynamic data routing. It has the following features:</p> <ul style="list-style-type: none"> • Powered by a 16-bit Instruction-Set micro-RISC engine • Multi channel DMA supporting up to 32 time-division multiplexed DMA channels • 48 events with total flexibility to trigger any combination of channels • Memory accesses including linear, FIFO, and 2D addressing • Shared peripherals between Arm and SDMA • Very fast Context-Switching with 2-level priority based preemptive multi tasking • DMA units with auto-flush and prefetch capability • Flexible address management for DMA transfers (increment, decrement, and no address changes on source and destination address) • DMA ports can handle unidirectional and bidirectional flows (Copy mode) • Up to 8-word buffer for configurable burst transfers for EMIv2.5 • Support of byte-swapping and CRC calculations • Library of Scripts and API is available
SJC	Secure JTAG Controller	<p>The SJC provides JTAG interface (designed to be compatible with JTAG TAP standards) to internal logic. The i.MX 8M Nano family of processors uses JTAG port for system debugging. The JTAG port must be accessible during platform initial laboratory bring-up, for troubleshooting, as well as for software debugging by authorized entities. The i.MX 8M Nano SJC incorporates three security modes for protecting against unauthorized accesses. Modes are selected through eFUSE configuration.</p>
SNVS	Secure Non-Volatile Storage	Secure Non-Volatile Storage, including Secure Real Time Clock, Security State Machine, Master Key Control, and Violation/Tamper Detection and reporting.
SPDIF1	Sony Philips Digital Interconnect Format	A standard audio file transfer format, developed jointly by the Sony and Phillips corporations. It supports Transmitter and Receiver functionality.
TEMPSENSOR	Temperature Sensor	Temperature sensor
TZASC	Trust-Zone Address Space Controller	The TZASC (TZC-380 by Arm) provides security address region control functions required for intended application. It is used on the path to the DRAM controller.
UART1 UART2 UART3 UART4	UART Interface	<p>Each of the UARTv2 modules supports the following serial data transmit/receive protocols and configurations:</p> <ul style="list-style-type: none"> • 7- or 8-bit data words, 1 or 2 stop bits, programmable parity (even, odd, or none) • Programmable baud rates up to 4 Mbps. This is a higher max baud rate relative to the 1.875 MHz, which is stated by the TIA/EIA-232-F standard. • 32-byte FIFO on Tx and 32 half-word FIFO on Rx supporting auto-baud

Table 4. i.MX 8M Nano modules list (continued)

Block mnemonic	Block name	Brief description
uSDHC1 uSDHC2 uSDHC3	SD/MMC and SDXC Enhanced Multi-Media Card / Secure Digital Host Controller	i.MX 8M Nano SoC characteristics: All the MMC/SD/SDIO controller IPs are based on the uSDHC IP. They are designed to support: <ul style="list-style-type: none"> • SD/SDIO standard, up to version 3.0. • MMC standard, up to version 5.1. • 1.8 V and 3.3 V operation, but do not support 1.2 V operation. • 1-bit/4-bit SD and SDIO modes, 1-bit/4-bit/8-bit MMC mode. One uSDHC controller (SD1) can support up to an 8-bit interface, the other controller (SD2) can only support up to a 4-bit interface.
USB 2.0	1x USB 2.0 controller and PHY	One USB controller and PHY that support USB 2.0.
WDOG1 WDOG2 WDOG3	Watchdog	The watchdog (WDOG) timer supports two comparison points during each counting period. Each of the comparison points is configurable to evoke an interrupt to the Arm core, and a second point evokes an external event on the WDOG line.

2.1 Recommended connections for unused input/output

If a function of the i.MX 8M Nano is not in use, the I/Os and power rails of that function can be terminated to reduce overall board power.

Table 5 shows the recommended connections for 14 x 14 mm package unused power supply rails.

Table 5. Recommended connections for 14 x 14 mm package unused power supply rails

Function	Ball Name	Recommendations if Unused
MIP-CSI and MIPI-DSI	VDD_MIPI_0P8, VDD_MIPI_1P2, VDD_MIPI_1P8	Leave unconnected
USB1	VDD_USB_0P8, VDD_USB_1P8, VDD_USB_3P3	Leave unconnected
GPU	VDD_GPU	Leave unconnected
Digital I/O supplies	NVCC_CLK, NVCC_ECSPi, NVDD_ENET, NVCC_GPIO1, NVCC_I2C, NVCC_JTAG, NVCC_NAND, NVCC_SAI2, NVCC_SAI3, NVCC_SAI5, NVCC_SD1, NVCC_SD2, NVCC_UART, NVCC_SNVS_1P8, PVCC0_1P8, PVCC1_1P8, PVCC2_1P8	All digital I/O supplies listed in this table must be powered under normal conditions whether the associated I/O pins are in use or not, and associated I/O pins need to enable pull in pad control register to limit any floating gate current.

Table 6 shows the recommended connections for 11 x 11 mm package unused power supply rails.

Table 6. Recommended connections for 11 x 11 mm package unused power supply rails

Function	Ball Name	Recommendations if Unused
MIP-CSI	VDD_MIPI_1P2	Leave unconnected
USB1	VDD_USB_0P8, VDD_USB_1P8, VDD_USB_3P3	Leave unconnected
Digital I/O supplies	NVCC_ENET_GPIO_SAI2, NVCC_CLK_JTAG_PVCC_1P8, NVCC_I2C_UART, NVCC_SAI3_SAI5, NVCC_SD1_NAND, NVCC_ECSPi, NVCC_SD2, NVCC_SNV5_1P8	All digital I/O supplies listed in this table must be powered under normal conditions whether the associated I/O pins are in use or not, and associated I/O pins need to enable pull in pad control register to limit any floating gate current.

Table 8 shows recommended connections for 14 x 14 mm package unused signal contacts/interfaces.

Table 7. Recommended connections for 14 x 14 mm package unused signal contacts/interfaces

Function	Ball Name	Recommendations if Unused
MIPI-CSI	MIPI_CSI_CLK_P, MIPI_CSI_CLK_N, MIPI_CSI_Dx_P, MIPI_CSI_Dx_N	Tie all signals to ground
MIPI-DSI	MIPI_VREG_CAP, MIPI_DSI_CLK_P, MIPI_DSI_CLK_N, MIPI_DSI_Dx_P, MIPI_DSI_Dx_N	Leave unconnected
USB1	USB1_VBUS, USB1_DN, USB1_DP, USB1_ID, USB1_TXRTUNE	Leave unconnected

Table 8 shows recommended connections for 11 x 11 mm package unused signal contacts/interfaces.

Table 8. Recommended connections for 11 x 11 mm package unused signal contacts/interfaces

Function	Ball Name	Recommendations if Unused
USB1	USB1_VBUS, USB1_DN, USB1_DP, USB1_ID, USB1_TXRTUNE	Leave unconnected
MIPI-CSI	MIPI_CSI_CLK_P, MIPI_CSI_CLK_N, MIPI_CSI_Dx_P, MIPI_CSI_Dx_N	Tie all signals to ground

3 Electrical characteristics

This section provides the device and module-level electrical characteristics for the i.MX 8M Nano family of processors.

3.1 Chip-level conditions

This section provides the device-level electrical characteristics for the IC. See [Table 9](#) for a quick reference to the individual tables and sections.

Table 9. i.MX 8M Nano chip-level conditions

For these characteristics, ...	Topic appears ...
Absolute maximum ratings	on page 14
Thermal resistance	on page 17
Operating ranges	on page 18
External clock sources	on page 21
Estimated power supply maximum currents	on page 22
Power modes	on page 23
Power supplies requirements and restrictions	on page 27

3.1.1 Absolute maximum ratings

CAUTION

Stresses beyond those listed under [Table 10](#) may affect reliability or cause permanent damage to the device. These are stress ratings only. Functional operation of the device at these or any other conditions beyond those indicated in the operating ranges or parameters tables is not implied.

Table 10. Absolute maximum ratings for 14 x 14 mm package

Parameter description	Symbol	Min	Max	Unit	Notes
Core supply voltages	VDD_ARM VDD_SOC	-0.3	1.15	V	—
Power supply for GPU	VDD_GPU	-0.3	1.15	V	—
DDR PHY supply voltage	VDD_DRAM	-0.3	1.15	V	—
DDR I/O supply voltage	NVCC_DRAM	-0.3	1.575	V	—
DRAM PLL supply voltage	VDD_DRAM_PLL_0P8	-0.3	1.15	V	—
	VDD_DRAM_PLL_1P8	-0.3	2.15	V	—
SNVS IO supply voltage	NVCC_SNVS_1P8	-0.3	2.15	V	—
VDD_SNVS supply voltage	VDD_SNVS_0V8	-0.3	0.95	V	—

Table 10. Absolute maximum ratings for 14 x 14 mm package (continued)

Parameter description	Symbol	Min	Max	Unit	Notes
GPIO supply voltage	NVCC_JTAG, NVCC_GPIO1, NVCC_ENET, NVCC_SD1, NVCC_SD2, NVCC_NAND, NVCC_SAI2, NVCC_SAI3, NVCC_SAI5, NVCC_ECSPi, NVCC_I2C, NVCC_UART, NVCC_CLK	-0.3	3.8	V	—
GPIO pre-driver supply voltage	PVCC0_1P8, PVCC1_1P8, PVCC2_1P8	-0.3	2.15	V	—
Isolated core supply voltage	VDD_ANA_0P8	-0.3	1.15	V	—
Analog core supply voltage	VDD_ANA0_1P8	-0.3	2.15	V	—
	VDD_ANA1_1P8	-0.3	2.15	V	—
Arm PLL supply voltage	VDD_ARM_PLL_0P8	-0.3	1.15	V	—
	VDD_ARM_PLL_1P8	-0.3	2.15	V	—
MIPI PHY supply voltage	VDD_MIPI_0P8	-0.3	1.15	V	—
	VDD_MIPI_1P2	-0.3	1.45	V	—
	VDD_MIPI_1P8	-0.3	2.15	V	—
USB PHY supply voltage	VDD_USB_0P8	-0.3	1.15	V	—
	VDD_USB_1P8	-0.3	2.15	V	—
	VDD_USB_3P3	-0.3	3.95	V	—
USB_VBUS input detected	USB1_VBUS	-0.3	3.95	V	—
XTAL supply voltage	VDD_24M_XTAL_1P8	-0.3	2.15	V	—
Storage temperature range	T _{STORAGE}	-40	150	°C	—

Table 11. Absolute maximum ratings for 11 x 11 mm package

Parameter description	Symbol	Min	Max	Unit	Notes
Core and DDR PHY supply voltage	VDD_SOC	-0.3	1.15	V	—
DDR I/O supply voltage	NVCC_DRAM	-0.3	1.575	V	—
DRAM PLL supply voltage	VDD_DRAM_PLL_1P8	-0.3	2.15	V	—
SNVS IO supply voltage	NVCC_SNVS_1P8	-0.3	2.15	V	—

Electrical characteristics

Table 11. Absolute maximum ratings for 11 x 11 mm package (continued)

Parameter description	Symbol	Min	Max	Unit	Notes
VDD_SNV5 supply voltage	VDD_SNV5_0V8	-0.3	0.95	V	—
GPIO supply voltage	NVCC_ENET_GPIO_SAI2, NVCC_I2C_UART, NVCC_SAI3_SAI5, NVCC_SD1_NAND, NVCC_ECSPi, NVCC_SD2	-0.3	3.8	V	—
GPIO supply voltage	NVCC_CLK_JTAG_PVCC_1P8	-0.3	2.15	V	—
XTAL, Analog core, MIPI PHY and USB PHY 1.8 V supply voltage	VDD_ANA1_XTAL_MIPI_USB_1P8	-0.3	2.15	V	—
Analog core and ARM PLL 1.8 V supply voltage	VDD_ANA0_ARM_PLL_1P8	-0.3	2.15	V	—
MIPI PHY 1.2 V supply voltage	VDD_MIPI_1P2	-0.3	1.45	V	—
USB PHY 3.3 V supply voltage	VDD_USB_3P3	-0.3	3.95	V	—
USB_VBUS input detected	USB1_VBUS	-0.3	3.95	V	—
XTAL supply voltage	VDD_24M_XTAL_1P8	-0.3	2.15	V	—
Storage temperature range	T _{STORAGE}	-40	150	°C	—

Table 12. Electrostatic discharge and latch up ratings

Parameter description	Rating	Reference	Comment	
Electrostatic Discharge (ESD)	Human Body Model (HBM)	±1000 V	JS-001-2017	—
	Charged Device Model (CDM)	±250 V	JS-002-2018	—
Latch UP (LU)	Immunity level: • Class I @ 25 °C ambient temperature • Class II @ 105 °C ambient temperature	A A	JESD78E	Mandatory requirement: JTAG_TMS pin must be connected with a 50 ohm series resistor near the component.

3.1.2 Thermal resistance

3.1.2.1 14 x 14 mm FCBGA package thermal resistance

Table 13 displays the 14 x 14 mm FCBGA package thermal resistance data.

Table 13. 14 x 14 mm package thermal resistance data

Rating	Test conditions	Symbol	Value	Unit	Notes
Junction to Ambient Natural Convection	Single layer board (1s) Four layer board (2s2p)	$R_{\theta JA}$	30	$^{\circ}\text{C}/\text{W}$	1, 2
Junction to Ambient Natural Convection	Four layer board (2s2p) Four layer board (2s2p)	$R_{\theta JA}$	22.9	$^{\circ}\text{C}/\text{W}$	1, 2, 3
Junction to Ambient (@200 ft/min)	Single layer board (1s)	$R_{\theta JMA}$	24	$^{\circ}\text{C}/\text{W}$	1, 3
Junction to Ambient (@200 ft/min)	Four layer board (2s2p)	$R_{\theta JMA}$	18.5	$^{\circ}\text{C}/\text{W}$	1, 3
Junction to Board	—	$R_{\theta JB}$	7.8	$^{\circ}\text{C}/\text{W}$	4
Junction to Case	—	$R_{\theta JC}$	4	$^{\circ}\text{C}/\text{W}$	5
Junction to Package Top	Natural Convection	Ψ_{JT}	0.2	$^{\circ}\text{C}/\text{W}$	6

¹ Junction temperature is a function of die size, on-chip power dissipation, package thermal resistance, mounting site (board) temperature, ambient temperature, air flow, power dissipation of other components on the board, and board thermal resistance.

² Per SEMI G38-87 and JESD51-2 with the single layer board horizontal.

³ Per JEDEC JESD51-6 with the board horizontal.

⁴ Thermal resistance between the die and printed circuit board per JEDEC JESD51-8. Board temperature is measured on the top surface of the board near the package.

⁵ Thermal resistance between the die and the case top surface as measured by the cold plate method (MIL SPEC-883 Method 1012.1).

⁶ Thermal characterization parameter indicating the temperature difference between package top and the junction temperature per JEDEC JESD51-2. When Greek letters are not available, the thermal characterization parameter is written as Psi-JT.

3.1.2.2 11 x 11 mm FCBGA package thermal resistance

Table 13 displays the 11 x 11 mm FCBGA package thermal resistance data.

Table 14. 11 x 11 mm thermal resistance data¹

Rating	Board type ²	Symbol	Value	Unit
			Coreless	
Junction to Ambient Thermal Resistance ³	JESD51-9, 2s2p	$R_{\theta JA}$	27.7	$^{\circ}\text{C}/\text{W}$
Junction-to-Top of Package Thermal Characterization Parameter ³	JESD51-9, 2s2p	Ψ_{JT}	5.2	$^{\circ}\text{C}/\text{W}$
Junction to Case Resistance ⁴	JESD51-9, 1s	$R_{\theta JC}$	11	$^{\circ}\text{C}/\text{W}$

¹ Non-uniform power is applied on the die.

Electrical characteristics

- ² Thermal test board meets JEDEC specification for this package (JESD51-9). Test board has 40 vias under die shadow mapped according to BGA layout under die. Each via is 0.2 mm in diameter and connects top layer with the first buried plane layer.
- ³ Determined in accordance to JEDEC JESD51-2A natural convection environment. Thermal resistance data in this report is solely for a thermal performance comparison of one package to another in a standardized specified environment. It is not meant to predict the performance of a package in an application-specific environment.
- ⁴ Junction-to-Case thermal resistance determined using an isothermal cold plate. Case temperature refers to the surface temperature at the package top side.

3.1.3 Operating ranges

Table 15 provides the operating ranges of the i.MX 8M Nano applications processor. For details on the chip's power structure, see the “Power Management Unit (PMU)” chapter of the *i.MX 8M Nano Applications Processor Reference Manual (IMX8MNRM)*.

Table 15. Operating ranges for 14 x 14 mm package

Symbol	Min	Typ	Max ¹	Unit	Comment
VDD_ARM	0.805	0.850	0.950	V	Power supply for Cortex® A53, 1.2 GHz
	0.900	0.950	1.000	V	Power supply for Cortex® A53, 1.4 GHz ²
VDD_SOC ³	0.805	0.850	0.900	V	Power supply for SoC logic ⁴ , Cortex® M7 600 MHz
	0.900	0.950	1.000	V	Power supply for SoC logic, overdrive mode, Cortex® M7 750 MHz
VDD_GPU ³	0.805	0.850	0.900	V	Power supply for 3D GPU, nominal mode, 400 MHz
	0.900	0.950	1.000	V	Power supply for 3D GPU, overdrive mode, 600 MHz
VDD_DRAM ³	0.805	0.850	0.900	V	Power supply for DDRC, 0.85 V supports up to 1.2 GHz (DDR clock)
	0.900	0.950	1.000	V	Power supply for DDRC, 0.95 V supports up to 1.6 GHz (DDR clock)
VDD_SNVS_0P8	0.760	0.800	0.900	V	Power supply for SNVS core logic
NVCC_SNVS_1P8	1.620	1.800	1.980	V	Power supply for GPIO pre-driver in SNVS bank
NVCC_JTAG, NVCC_GPIO1, NVCC_ENET, NVCC_SD1, NVCC_SD2, NVCC_NAND, NVCC_SAI2, NVCC_SAI3, NVCC_SAI5, NVCC_ECSPi, NVCC_I2C, NVCC_UART, NVCC_CLK	1.650	1.800	1.950	V	Power supply for GPIO when it is in 1.8 V mode
	3.000	3.300	3.600	V	Power supply for GPIO when it is in 3.3 V mode
NVCC_ENET	2.250	2.500	2.750	V	Power supply for GPIO when it is in 2.5 V mode

Table 15. Operating ranges for 14 x 14 mm package (continued)

Symbol	Min	Typ	Max ¹	Unit	Comment
PVCC0_1P8, PVCC1_1P8, PVCC2_1P8	1.650	1.800	1.950	V	Power supply for GPIO pre-driver
VSS	—	—	—	V	Ground for all core logic and I/O
NVCC_DRAM	1.283	1.35	1.425	V	DDR3L
	1.14	1.2	1.26	V	DDR4
	1.06	1.1	1.14	V	LPDDR4
DRAM_VREF	0.49 x NVCC_DRAM	0.5 x NVCC_DRAM	0.51 x NVCC_DRAM	V	Internal output, no connection is needed.
VDD_DRAM_PLL_0P8	0.805	0.850	0.900	V	Power supply for DRAM PLL, nominal mode
	0.900	0.950	1.000	V	Power supply for DRAM PLL, overdrive mode
VDD_ANA0_1P8 VDD_ANA1_1P8	1.71	1.8	1.89	V	Analog 1.8 V core power
VDD_ANA_0P8	0.805	0.850	0.900	V	Supplies for Analog PLL, nominal mode
	0.900	0.950	1.000	V	Supplies for Analog PLL, overdrive mode
VDD_ARM_PLL_0P8	0.805	0.850	0.900	V	Power supply for Arm PLL, nominal mode
	0.900	0.950	1.000	V	Power supply for Arm PLL, overdrive mode
VDD_ARM_PLL_1P8	1.71	1.8	1.89	V	Arm PLL 1.8 V power
VDD_24M_XTAL_1P8	1.71	1.8	1.89	V	XTAL 1.8 V power
VDD_DRAM_PLL_1P8	1.71	1.8	1.89	V	Analog 1.8 V core power
VDD_MIPI_0P8	0.805	0.850	0.900	V	Digital supply for MIPI PHY, nominal mode
	0.900	0.950	1.000	V	Digital supply for MIPI PHY, overdrive mode
VDD_MIPI_1P2	1.14	1.2	1.26	V	1.2 V power for analog
VDD_MIPI_1P8	1.71	1.8	1.89	V	1.8 V power for PLL and analog
VDD_USB_0P8	0.805	0.850	0.900	V	Digital power supply from PHY's I/O power pads, nominal mode
	0.900	0.950	1.000	V	Digital power supply from PHY's I/O power pads, overdrive mode
VDD_USB_1P8	1.71	1.80	1.89	V	1.8 V analog power supply
VDD_USB_3P3	3.069	3.30	3.6	V	3.3 V analog power supply

Electrical characteristics

Table 15. Operating ranges for 14 x 14 mm package (continued)

Symbol	Min	Typ	Max ¹	Unit	Comment
USB1_VBUS	1.34	—	3.60	V	USB_VBUS input detect signal
Temperature Sensor Accuracy ⁵	—	±3	±5	°C	Sensing temperature range 10°C to 105°C
T _J	-40	—	+105	°C	See Table 3 for complete list of junction temperature capabilities.

¹ Applying the maximum voltage results in maximum power consumption and heat generation. A voltage set point = (V_{min} + the supply tolerance) is recommended. This results in an optimized power/speed ratio.

² For VDD_ARM at 1.0V typical, Power-on Hours will decreased if junction temperature is increased. Please refer to *i.MX 8M Nano Product Lifetime Usage (AN12983)* for details.

³ VDD_DRAM, VDD_SOC, and VDD_GPU are required to be tied together and keep same or ground.

⁴ Booting VDD_SOC at 0.800 V ±5% is acceptable (V_{min} = 0.760 V). Software is expected to program the VDD_SOC voltage to the typical value in this table prior to first DRAM memory access.

⁵ “EN” of TMU Enable Register (TMU_TER) is required to be always enabled for the part to operate correctly.

Table 16. Operating ranges for 11 x11 mm package

Symbol	Min	Typ	Max ¹	Unit	Comment
VDD_SOC	0.805	0.850	0.900	V	Power supply for SoC logic ² , Cortex® M7 600 MHz; Cortex® A53, 1.2 GHz, nominal mode, 1.2 GHz DDR clock
	0.900	0.950	1.000	V	Power supply for SoC logic ² , Cortex® M7 750 MHz; Cortex® A53, 1.4 GHz, overdrive mode, 1.6 GHz DDR clock
VDD_SNVS_0P8	0.760	0.800	0.900	V	Power supply for SNVS core logic
NVCC_SNVS_1P8	1.620	1.800	1.980	V	Power supply for GPIO pre-driver in SNVS bank
NVCC_I2C_UART, NVCC_SAI3_SAI5, NVCC_SD1_NAND, NVCC_ECSPi, NVCC_SD2, NVCC_ENET_GPIO_SAI2	1.650	1.800	1.950	V	Power supply for GPIO when it is in 1.8 V mode
	3.000	3.300	3.600	V	Power supply for GPIO when it is in 3.3 V mode
NVCC_CLK_JTAG_PVCC_1P8	1.650	1.800	1.950	V	Power supply for GPIO and GPIO pre-driver in 1.8 V mode
VSS	—	—	—	V	Ground for all core logic and I/O
NVCC_DRAM	1.283	1.35	1.425	V	DDR3L
	1.14	1.2	1.26	V	DDR4
	1.06	1.1	1.14	V	LPDDR4
DRAM_VREF	0.49 x NVCC_DRAM	0.5 x NVCC_DRAM	0.51 x NVCC_DRAM	V	Internal output, no connection is needed.

Table 16. Operating ranges for 11 x11 mm package (continued)

Symbol	Min	Typ	Max ¹	Unit	Comment
VDD_ANA1_XTAL_MIPI_U SB_1P8, VDD_ANA0_ARM_PLL_1P 8	1.71	1.8	1.89	V	1.8 V power for Analog core, XTAL, MIPI PLL and analog, USB analog and ARM PLL
VDD_DRAM_PLL_1P8	1.71	1.8	1.89	V	Analog 1.8 V core power
VDD_MIPI_1P2	1.14	1.2	1.26	V	1.2 V power for analog
VDD_USB_3P3	3.069	3.30	3.6	V	3.3 V analog power supply
USB1_VBUS	1.34	—	3.60	V	USB_VBUS input detect signal
Temperature Sensor Accuracy ²	—	±3	±5	°C	Sensing temperature range 10°C to 105°C
T _J	-40	—	+105	°C	See Table 3 for complete list of junction temperature capabilities.

¹ Applying the maximum voltage results in maximum power consumption and heat generation. A voltage set point = (V_{min} + the supply tolerance) is recommended. This results in an optimized power/speed ratio.

² “EN” of TMU Enable Register (TMU_TER) is required to be always enabled for the part to operate correctly.

3.1.4 External clock sources

Each i.MX 8M Nano processor has two external input system clocks: a low frequency (RTC_XTALI) and a high frequency (XTALI).

The RTC_XTALI is used for low-frequency functions. It supplies the clock for wake-up circuit, power-down real time clock operation, and slow system and watch-dog counters. The clock input can only be connected to an external oscillator. RTC_XTALO should be directly connected to VDD_SNVS_0P8.

The system clock input XTALI is used to generate the main system clock. It supplies the PLLs and other peripherals. The system clock input can be connected to either an external oscillator or a crystal using internal oscillator amplifier.

Table 17 shows the interface frequency requirements.

Table 17. External input clock frequency

Parameter Description	Symbol	Min	Typ	Max	Unit
RTC_XTALI Oscillator ¹	f _{ckil}	—	32.768 ²	—	kHz
XTALI Oscillator ^{1,3}	f _{xtal}		24		MHz

¹ The required frequency stability of this clock source is application dependent.

² Recommended nominal frequency 32.768 kHz.

³ External oscillator or a fundamental frequency crystal appropriately coupled to the internal oscillator amplifier.

The typical values shown in Table 17 are required for use with NXP software to ensure precise time keeping and USB operation. For RTC_XTALI operation, an external oscillator is necessary. RTC_XTALO should be directly connected to VDD_SNVS_0P8 when using an external 32.768 kHz oscillator.

NOTE

There is no internal RC oscillator.

Table 18 shows the external input clock for OSC32K.

Table 18. External input clock for OSC32K

	Symbol	Min	Typ	Max	Unit
Frequency	f	—	32.768	—	kHz
RTC_XTALI	VIH	0.7 x NVCC_SNV5_1P8	—	NVCC_SNV5_1P8	V
	VIL	0	—	0.3 x NVCC_SNV5_1P8	V

3.1.5 Estimated power supply maximum currents

Power consumption is highly dependent on the application. Estimating the maximum supply currents required for power supply design is difficult because the use cases that requires maximum supply current is not a realistic use cases.

The table below represents the estimated maximum current on the power supply rails and should be used as a guideline for power supply selection. The data below is based on a combination of design simulation and characterization data based on typical datasheet voltages. Actual power consumption for typical use cases are lower than values presented on the table below.

Table 19. Estimated power supply maximum currents for 14 x 14 mm package

Power rail	Max current	Unit
VDD_ARM	2200	mA
VDD_SOC	1000	mA
VDD_GPU	800	mA
VDD_DRAM	800	mA
VDD_ANA_0P8	50	mA
VDD_ANA0_1P8 VDD_ANA1_1P8	250	mA
NVCC_SNV5_1P8	3	mA
NVCC_<XXX> NVCC_DRAM	$I_{max} = N \times C \times V \times (0.5 \times F)$ Where: N—Number of IO pins supplied by the power line C—Equivalent external capacitive load V—IO voltage (0.5 x F)—Data change rate. Up to 0.5 of the clock rate (F). In this equation, I_{max} is in Amps, C in Farads, V in Volts, and F in Hertz.	
DRAM_VFEF	10	mA

Table 20. Estimated power supply maximum currents for 11 x 11 mm package

Power rail	Max current	Unit
VDD_SOC	3000	mA
NVCC_SNVS_1P8	3	mA
VDD_ANA1_XTAL_MIPI_USB_1P8, VDD_ANA0_ARM_PLL_1P8, VDD_DRAM_PLL_1P8	250	mA
VDD_MIPI_1P2	100	mA
NVCC_<XXX>	$I_{max} = N \times C \times V \times (0.5 \times F)$ Where: N—Number of IO pins supplied by the power line C—Equivalent external capacitive load V—IO voltage (0.5 x F)—Data change rate. Up to 0.5 of the clock rate (F). In this equation, I_{max} is in Amps, C in Farads, V in Volts, and F in Hertz.	
NVCC_DRAM		
DRAM_VFEF	10	mA

3.1.6 Power modes

The i.MX 8M Nano supports the following power modes:

- **RUN Mode:** All external power rails are on, CPU is active and running; other internal modules can be on/off based on application.
- **IDLE Mode:** When there is no thread running and all high-speed devices are not active, the CPU can automatically enter this mode. The CPU can be in the power-gated state but with L2 data retained, DRAM and the bus clock are reduced. Most of the internal logic is clock gated but still remains powered. The M7 core can remain running. Compared with RUN mode, all the external power rails from the PMIC remain the same, and most of the modules still remain in their state.
- **SUSPEND Mode:** The most efficient power saving mode where all the clocks are off and all the unnecessary power supplies are off.
- **SNVS Mode:** This mode is also called RTC mode. Only the power for the SNVS domain remains on to keep RTC and SNVS logic alive.
- **OFF Mode:** All power rails are off.

Table 21. Chip power in different LP mode for 14 x 14 mm package

Mode	Supply	Typ. ¹	Unit
SNVS	VDD_SNVS_0P8	0.10	mW
	NVCC_SNVS_1P8	1.20	
	Total ²	1.30	

Table 21. Chip power in different LP mode for 14 x 14 mm package (continued)

Mode	Supply	Typ. ¹	Unit
SUSPEND	NVCC	0.80	mW
	NVCC_DRAM	2.40	
	NVCC_ENET	0.10	
	NVCC_SNVS_1P8	0.20	
	PVCC	0.60	
	VDD_DRAM	9.40	
	VDD_MIPI_0P8	0.10	
	VDD_SNVS_0P8	0.10	
	VDD_SOC	4.50	
	VDD_ARM_PLL_0P8	0.10	
	VDD_USB_0P8	2.50	
	Total ²	20.80	
	Low-V SUSPEND ³	NVCC	
NVCC_DRAM		1.50	
NVCC_ENET		0.10	
NVCC_SNVS_1P8		0.20	
PVCC		0.60	
VDD_DRAM		6.80	
VDD_MIPI_0P8		0.20	
VDD_SNVS_0P8		0.10	
VDD_SOC		3.50	
VDD_ARM_PLL_0P8		0.10	
VDD_USB_0P8		2.60	
Total ²		16.40	

¹ All the power numbers defined in the table are for information only. These numbers are based on typical silicon at 25°C, under non-OS environment and use case dependent. For power numbers with OS and real use cases, see *Power consumption measurement application note* for more details.

² Sum of the listed supply rails.

³ Low-V suspend mode is low voltage suspend mode. Comparing with suspend mode (VDD_SOC/GPU/DRAM at 0.8 V), Low-V suspend mode sets VDD_SOC/GPU/DRAM at 0.75 V.

Table 22. Chip power in different LP mode for 11 x 11 mm package

Mode	Supply	Typ. ¹	Unit
SUSPEND	VDD_SOC	12.1	mW
	NVCC_DRAM	2	
	VDD_SNVS_0P8	0.1	
	NVCC_SNVS_1P8	0.2	
	NVCC_CLK_JTAG_PVCC_1P8	1	
	NVCC_I2C_UART NVCC_SAI3_SAI5 NVCC_SD1_NAND NVCC_ECSPi NVCC_SD2	0.2	
	NVCC_ENET_GPIO_SAI2	0.3	
	Total	15.9	
Low-V SUSPEND ²	VDD_SOC	9.9	mW
	NVCC_DRAM	1.5	
	VDD_SNVS_0P8	0.1	
	NVCC_SNVS_1P8	0.2	
	NVCC_CLK_JTAG_PVCC_1P8	0.9	
	NVCC_I2C_UART NVCC_SAI3_SAI5 NVCC_SD1_NAND NVCC_ECSPi NVCC_SD2	0.2	
	NVCC_ENET_GPIO_SAI2	0.3	
	Total	13.1	
SNVS	VDD_SNVS_0P8	0.1	mW
	NVCC_SNVS_1P8	0.3	
	Total	0.4	

¹ All the power numbers defined in the table are for information only. These numbers are based on typical silicon at 25°C, under non-OS environment and use case dependent. For power numbers with OS and real use cases, see *Power consumption measurement application note* for more details.

² Low-V suspend mode is low voltage suspend mode. Comparing with suspend mode (VDD_SOC at 0.8 V), Low-V suspend mode sets VDD_SOC at 0.75 V.

Table 23 and Table 25 summary the power supply states in all the power modes.

Electrical characteristics

Table 23. The power supply states for 14 x 14 mm package

Power rail	OFF	SNVS	SUSPEND ¹	IDLE	RUN
VDD_ARM	OFF	OFF	OFF	ON	ON
VDD_SOC	OFF	OFF	ON	ON	ON
VDD_GPU	OFF	OFF	OFF	OFF	ON/OFF
VDD_DRAM	OFF	OFF	ON	ON	ON
Misc_1P8 ²	OFF	OFF	ON	ON	ON
Misc_0P8 ²	OFF	OFF	ON	ON	ON
VDD_MIPI_1P2	OFF	OFF	ON	ON	ON
VDD_MIPI_0P8	OFF	OFF	ON	ON	ON
VDD_DRAM_PLL_0P8	OFF	OFF	ON	ON	ON
VDD_SNVS_0P8	OFF	ON	ON	ON	ON
NVCC_SNVS_1P8	OFF	ON	ON	ON	ON
NVCC_<XXX>	OFF	OFF	ON	ON	ON
PVCCx_1P8	OFF	OFF	ON	ON	ON
NVCC_DRAM	OFF	OFF	ON	ON	ON

¹ SUSPEND is covering normal suspend mode (VDD_SOC/GPU/DRAM at 0.8 V) and Low-V suspend (VDD_SOC/GPU/DRAM at 0.75 V).

² See [Table 24](#)

Table 24. Group name

Misc_1P8	VDD_24M_XTAL_1P8 VDD_ANA0_1P8 VDD_ANA1_1P8 VDD_ARM_PLL_1P8 VDD_DRAM_PLL_1P8 VDD_MIPI_1P8 VDD_USB_1P8
Misc_0P8	VDD_ANA_0P8 VDD_ARM_PLL_0P8 VDD_USB_0P8

Table 25. The power supply states for 11 x 11 mm package

Power rail	OFF	SNVS	SUSPEND	IDLE	RUN
VDD_SOC	OFF	OFF	ON	ON	ON
VDD_ANA1_XTAL_MIPI_USB_1P8, VDD_ANA0_ARM_PLL_1P8, VDD_DRAM_PLL_1P8	OFF	OFF	ON	ON	ON
VDD_MIPI_1P2	OFF	OFF	ON	ON	ON
VDD_SNVS_0P8	OFF	ON	ON	ON	ON
NVCC_SNVS_1P8	OFF	ON	ON	ON	ON
NVCC_<XXX>	OFF	OFF	ON	ON	ON
NVCC_DRAM	OFF	OFF	ON	ON	ON

3.2 Power supplies requirements and restrictions

The system design must comply with power-up sequence, power-down sequence, and steady state guidelines as described in this section to guarantee the reliable operation of the device. Any deviation from these sequences may result in the following situations:

- Excessive current during power-up phase
- Prevention of the device from booting
- Irreversible damage to the processor (worst-case scenario)

3.2.1 Power-up sequence

Figure 3 illustrates the power-up sequence for 14 x 14 mm package of i.MX 8M Nano applications processor.

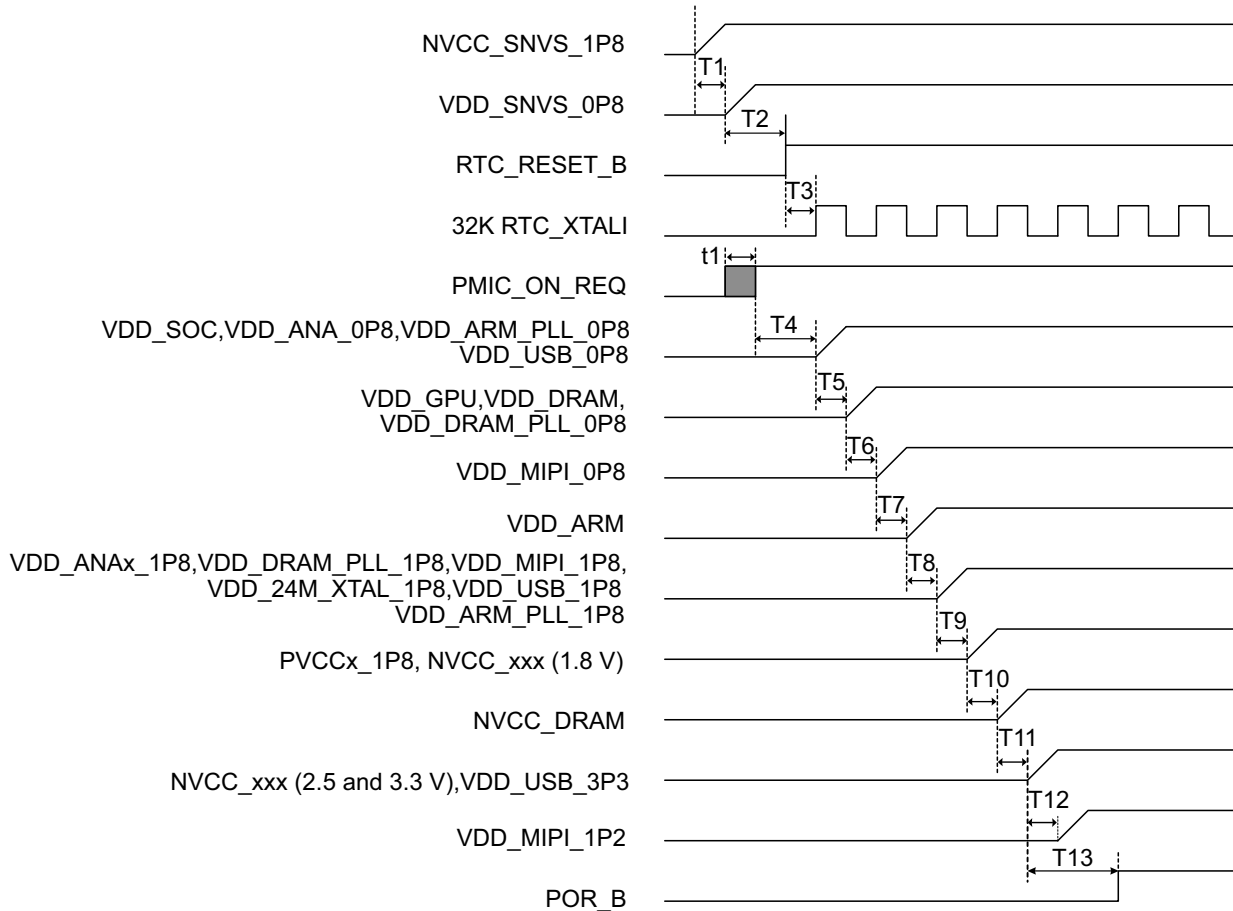

Figure 3. The power-up sequence for 14 x 14 mm package

NOTE

VDD_MIPI_1P2 should power up after VDD_MIPI_0P8 and VDD_MIPI_1P8, and it can power up before the POR_B release or after the POR_B release.

Table 26 represents the timing parameters of the power-up sequence for 14 x 14 mm package.

Table 26. Power-up sequence for 14 x 14 mm package

	Description	Min	Typ	Max	Unit
T1	Delay from NVCC_SNVS_1P8 to VDD_SNVS_0P8	0	2	—	ms
T2	Delay from VDD_SNVS_0P8 high or RTC_SET_B de-assert	0	10	—	ms
T3	Delay from RTC_RESET_B de-assert to stable 32 k existed	—	40	100	μs
T4	Delay from PMIC_ON_REQ assert to analog 0.8 V on	0	0.2	—	ms
T5	Delay from analog 0.8 V on to analog 0.8/0/9 V on	0	2	—	ms
T6	Delay from analog 0.8/0.9 V on to PHY 0.9 V on	0	15	—	μs
T7	Delay from PHY 0.9 V on to VDD_ARM on	0	2	—	ms
T8	Delay from VDD_ARM on to analog 1.8 V on	0	15	—	μs
T9	Delay from analog 1.8 V on to digital 1.8 V on	0	2	—	ms
T10	Delay from digital 1.8 V on to NVCC_DRAM on	0	2	—	ms
T11	Delay from NVCC_DRAM on to digital 2.5 V and 3.3 V on	0	2	—	ms
T12	Delay from digital 2.5 V and 3.3 V on to PHY 1.2 V on	0	2	—	ms
T13 ¹	Delay from digital 2.5 V and 3.3 V on to POR_B de-assert	0	20	—	ms
t1	Uncertain period before PMIC_ON_REQ assert during VDD_SNVS_0P8 ramp up.				
	For ramp up requirement, only VDD_ANA0_1P8 has 5 μs minimum requirement, others do not have such requirement. During power-up, make sure NVCC_xxx - PVCCx_1P8 < 2 V.				

¹ The values of T13 depend on T2. RTC_RESET_B must be de-assert before POR_B de-asserts.

Figure 4 illustrates the power-up sequence for 11 x 11 mm package of i.MX 8M Nano applications processor.

Electrical characteristics

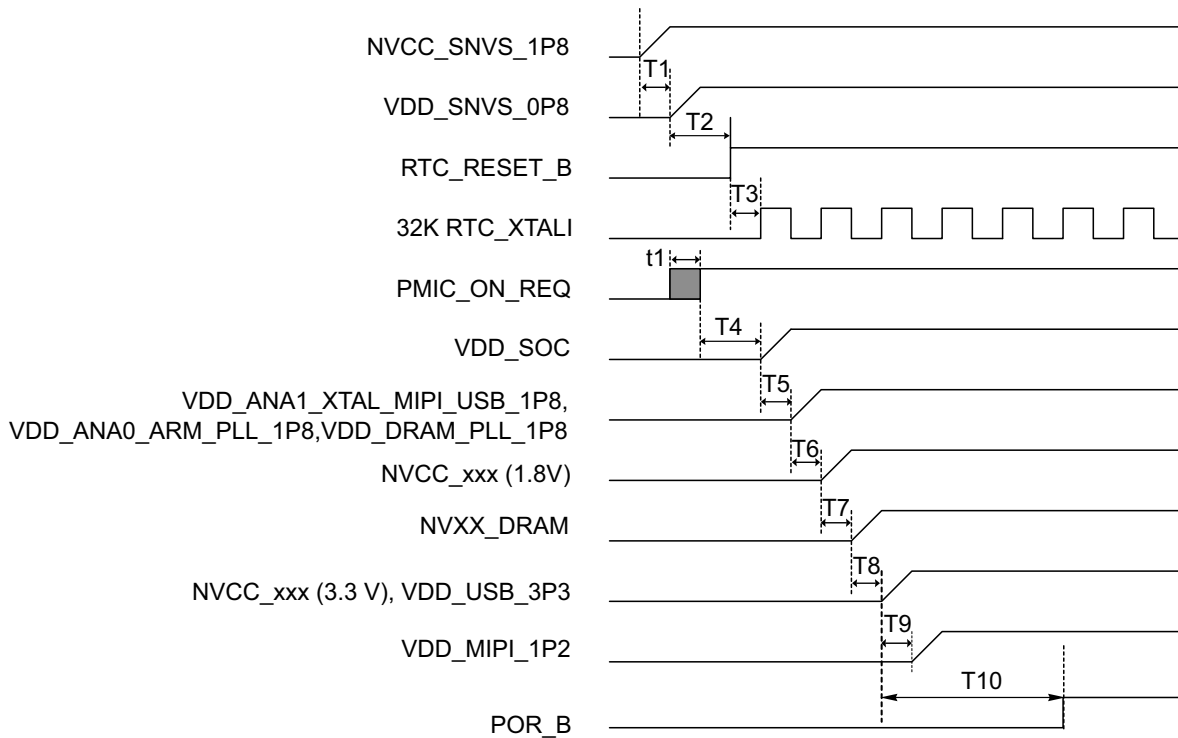

Figure 4. The power-up sequence for 11 x 11 mm package

NOTE

VDD_MIPI_1P2 should power up after Analog 1.8 V on, and it can power up before POR_B release or after POR_B release.

Table 27 represents the timing parameters of the power-up sequence for 11 x 11 mm package.

Table 27. Power-up sequence for 11 x 11 mm package

	Description	Min	Typ	Max	Unit
T1	Delay from NVCC_SNVS_1P8 to VDD_SNVS_0P8	0	2	—	ms
T2	Delay from VDD_SNVS_0P8 high or RTC_SET_B de-assert	0	10	—	ms
T3	Delay from RTC_RESET_B de-assert to stable 32 k existed	—	40	100	μs
T4	Delay from PMIC_ON_REQ assert to ARM, analog and PHY 0.8/0.9 V on	0	5	—	ms
T5	Delay from SOC, analog and PHY 0.8/0.9 V to analog 1.8 V on	0	15	—	μs
T6	Delay from analog 1.8 V on to digital 1.8 V on	0	2	—	ms
T7	Delay from digital 1.8 V on to NVCC_DRAM on	0	2	—	ms
T8	Delay from NVCC_DRAM on to digital 3.3 V on	0	2	—	ms
T9	Delay from analog 1.8 V on to PHY 1.2 V on	0	2	—	ms
T10	Delay from digital 3.3 V on to POR_B de-assert ¹	0	20	—	ms

Table 27. Power-up sequence for 11 x 11 mm package (continued)

	Description	Min	Typ	Max	Unit
t1	Uncertain period before PMIC_ON_REQ assert during VDD_SNVS_0P8 ramp up.				
	For ramp up requirement, only VDD_ANA0_ARM_PLL_1P8 has 5 μ s minimum requirement, others do not have such requirement.				

¹ The values of T10 depend on T2. RTC_RESET_B must be de-assert before POR_B de-asserts.

3.2.2 Power-down sequence

Figure 5 illustrates the power-down sequence for 14 x 14 mm package of i.MX 8M Nano applications processor.

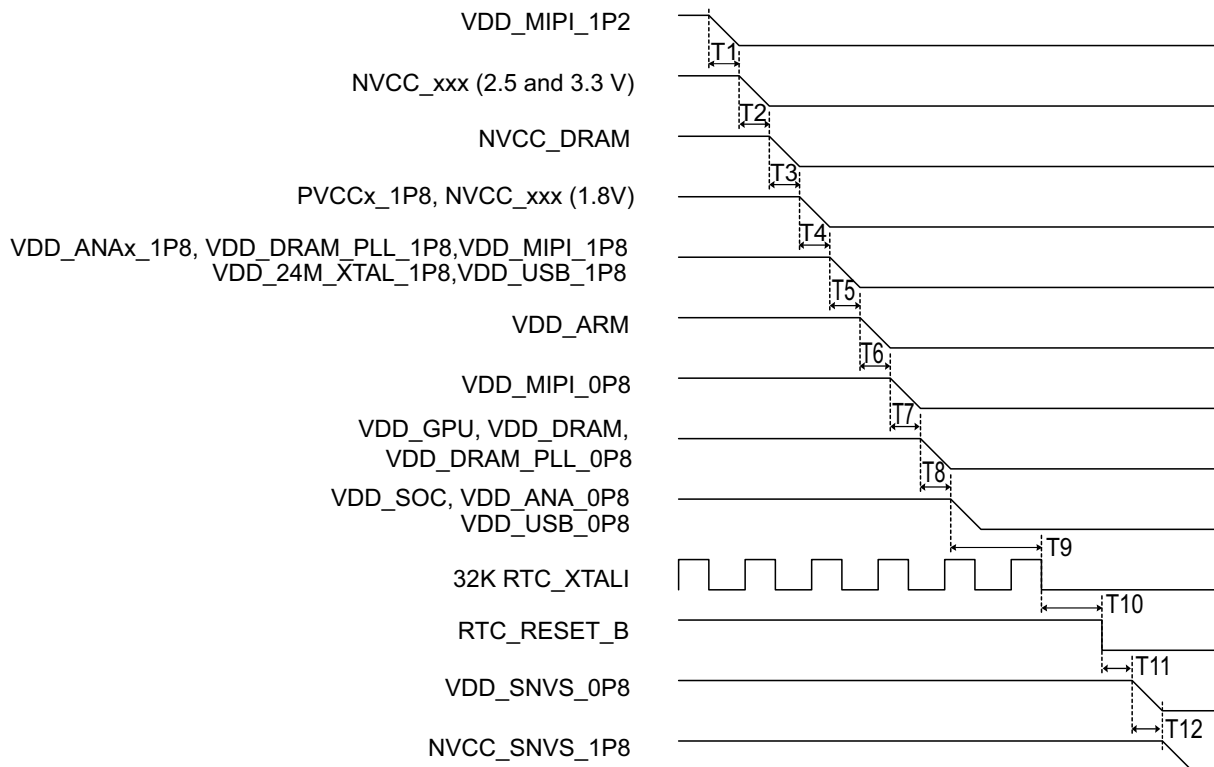

Figure 5. The power-down sequence for 14 x 14 mm package

Electrical characteristics

Table 28 represents the timing parameters of the power-down sequence for 14 x 14 mm package.

Table 28. Power-down sequence for 14 x 14 mm package

	Description	Min	Typ	Max	Unit
T1	Delay from PHY 1.2 V off to digital 2.5 V and 3.3 V off	0	10	—	ms
T2	Delay from digital 2.5 V and 3.3 V off to NVCC_DRAM off	0	10	—	ms
T3	Delay from NVCC_DRAM off to digital 1.8 V off	0	10	—	ms
T4	Delay from digital 1.8 V off to analog 1.8 V off	0	10	—	ms
T5	Delay from analog 1.8 V off to VDD_ARM off	0	10	—	ms
T6	Delay from VDD_ARM off to PHY 0.9 V off	0	10	—	ms
T7	Delay from PHY 0.9 V off to analog 0.8/0.9 V off	0	10	—	ms
T8	Delay from analog 0.8/0.9 V off to analog 0.8 V off	0	10	—	ms
T9	Delay from analog 0.8 V off to 32k off	0	10	—	ms
T10	Delay from 32k off to RTC_RESET_B assert	0	10	—	ms
T11	Delay from RTC_RESET_B assert to VDD_SNVS_0P8 off	0	10	—	ms
T12	Delay from VDD_SNVS_0P8 off to NVCC_SNVS_1P8 off	0	10	—	ms
	During power-down, make sure NVCC_xxx - PVCCx_1P8 < 2 V.				

Figure 6 illustrates the power-down sequence for 11 x 11 mm package of i.MX 8M Nano applications processor.

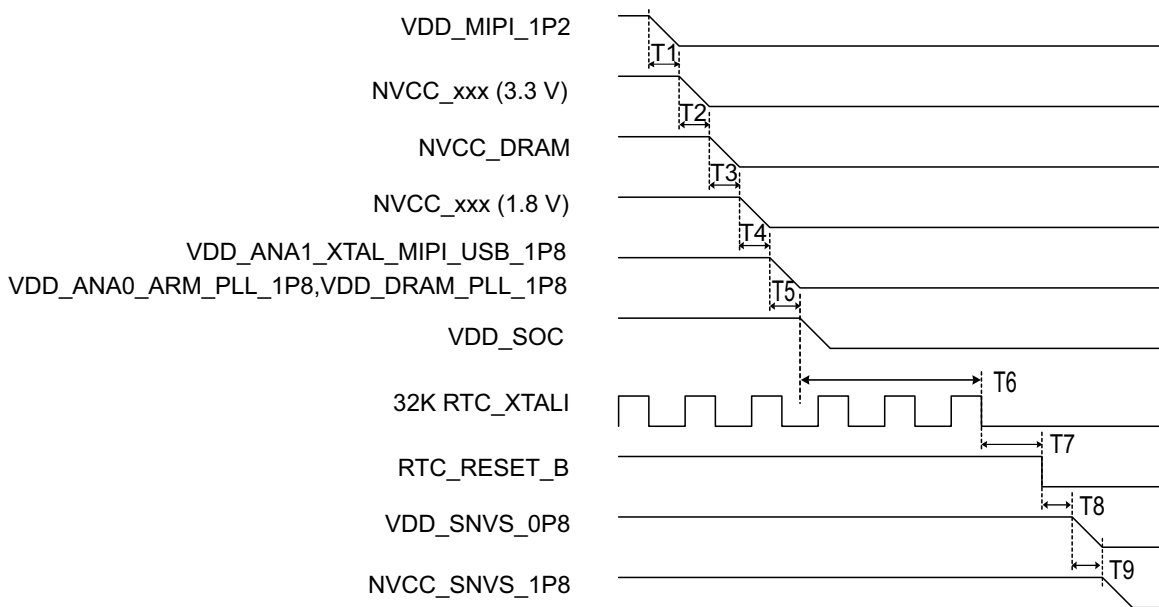

Figure 6. The power-down sequence for 11 x 11 mm package

Table 29 represents the timing parameters of the power-down sequence for 11 x 11 mm package.

Table 29. Power-down sequence for 11 x 11 mm package

	Description	Min	Typ	Max	Unit
T1	Delay from PHY 1.2 V off to digital 2.5 V and 3.3 V off	0	10	—	ms
T2	Delay from digital 2.5 V and 3.3 V off to NVCC_DRAM off	0	10	—	ms
T3	Delay from NVCC_DRAM off to digital 1.8 V off	0	10	—	ms
T4	Delay from digital 1.8 V off to analog 1.8 V off	0	10	—	ms
T5	Delay from analog 1.8 V off to VDD_SOC off	0	40	—	ms
T6	Delay from VDD_SOC off to 32k off	0	10	—	ms
T7	Delay from 32k off to RTC_RESET_B assert	0	10	—	ms
T8	Delay from RTC_RESET_B assert to VDD_SNVS_0P8 off	0	10	—	ms
T9	Delay from VDD_SNVS_0P8 off to NVCC_SNVS_1P8 off	0	10	—	ms

3.3 PLL electrical characteristics

Table 30 shows PLL electrical characteristics.

Table 30. PLL electrical parameters

PLL type	Parameter	Value
AUDIO_PLL1	Clock output range	Maximum 650 MHz
	Reference clock	24 MHz
	Lock time ¹	500 μ s
AUDIO_PLL2	Clock output range	Maximum 650 MHz
	Reference clock	24 MHz
	Lock time	500 μ s
VIDEO_PLL1	Clock output range	Maximum 650 MHz
	Reference clock	24 MHz
	Lock time	500 μ s
SYS_PLL1	Clock output range	800 MHz
	Reference clock	24 MHz
	Lock time	50 μ s
SYS_PLL2	Clock output range	1 GHz
	Reference clock	24 MHz
	Lock time	50 μ s

Table 30. PLL electrical parameters (continued)

PLL type	Parameter	Value
SYS_PLL3	Clock output range	600 MHz — 1 GHz
	Reference clock	24 MHz
	Lock time	50 μ s
ARM_PLL	Clock output range	800 MHz — 2 GHz
	Reference clock	24 MHz
	Lock time	50 μ s
M7_ALT_PLL	Clock output range	400 MHz — 800 MHz
	Reference clock	24 MHz
	Lock time	50 μ s
DRAM_PLL	Clock output range	400 MHz — 800 MHz
	Reference clock	24 MHz
	Lock time	500 μ s
GPU_PLL	Clock output range	800 MHz — 1600 MHz
	Reference clock	24 MHz
	Lock time	50 μ s

¹ Lock time is referring from PLL enable to valid lock flag time.

3.4 On-chip oscillators

3.4.1 OSC24M

A 24 MHz oscillator is used as the primary clock source for the PLLs to generate the clock for the CPU, BUS, and high-speed interfaces. For fractional PLLs, the 24 MHz clock from the oscillator can be used as the PLL reference clock directly.

Table 31. Crystal specifications¹

Parameter Description	Min	Typ	Max	Unit
Frequency	—	24	—	MHz
Clload	—	12	—	pF
Drive level	100	—	—	μ W
ESR	—	—	80	Ω

¹ Actual working drive level is depend on real design. Please contact crystal vendor for selecting drive level of crystal.

3.4.2 OSC32K

An external 32.768 kHz oscillator is necessary.

3.5 General purpose I/O (GPIO) DC parameters

Table 32 shows DC parameters for GPIO pads. The parameters in Table 32 are guaranteed per the operating ranges in Table 15, unless otherwise noted.

Table 32. GPIO DC parameters

Parameter	Symbol	Test Conditions	Min	Typ	Max	Unit
High-level output voltage	$V_{OH(1.8V)}$	$I_{OH} = 1.6/3.2/6.4/9.6 \text{ mA (1.8 V)}$ $I_{OH} = 2/4/8/12 \text{ mA (3.3 V)}$	$0.8 \times V_{DD}$	—	V_{DD}	V
	$V_{OH(3.3V)}$		$0.8 \times V_{DD}$	—	V_{DD}	V
Low-level output voltage	$V_{OL(1.8V)}$	$I_{OL} = 1.6/3.2/6.4/9.6 \text{ mA (1.8 V)}$ $I_{OL} = 2/4/8/12 \text{ mA (3.3 V)}$	0	—	$0.2 \times V_{DD}$	V
	$V_{OL(3.3V)}$		0	—	$0.2 \times V_{DD}$	V
High-level input voltage	V_{IH}	—	$0.7 \times V_{DD}$	—	$V_{DD} + 0.3$	V
Low-level input voltage	V_{IL}	—	-0.3	—	$0.3 \times V_{DD}$	V
Pull-up resistor	—	$V_{DD} = 1.65 - 1.95V$ Temp = 0 - 95 °C	12	22	49	K Ω
Pull-down resistor	—		13	23	48	K Ω
Pull-up resistor	—	$V_{DD} = 2.25 - 2.75V$ Temp = 0 - 95 °C	13	24	69	K Ω
Pull-down resistor	—		9.1	33	69	K Ω
Pull-up resistor	—	$V_{DD} = 3.0 - 3.6V$ Temp = 0 - 95 °C	18	37	72	K Ω
Pull-down resistor	—		24	43	87	K Ω
High level input current	I _{IH}	—	-4	—	4	μA
Low level input current	I _{IL}	—	-0.7	—	0.7	μA

Table 33. Additional leakage parameters

Parameter	Symbol	Pins	Min	Max	Unit
High level input current	I _{IH}	USB1_Dx	-30	30	μA
		MIPI_CSI	-4	4	
		USB1_ID, ONOFF, POR_B	-1	1	
Low level input current	I _{IL}	USB1_ID	-200	200	μA
		USB1_Dx	-6	6	
		MIPI_CSI, ONOFF, POR_B	-0.7	0.7	

3.5.1 DDR I/O DC electrical characteristics

The DDR I/O pads support LPDDR 4, DDR4, and DDR3L operational modes. The DDR Memory Controller (DDRMC) is designed to be compatible with JEDEC-compliant SDRAMs.

DDRMC operation is contingent upon the board’s DDR design adherence to the DDR design and layout requirements stated in the hardware development guide for the i.MX 8M Nano applications processor.

3.6 I/O AC parameters

This section includes the AC parameters of the following I/O types:

- General Purpose I/O (GPIO)

The GPIO load circuit and output transition time waveforms are shown in [Figure 7](#) and [Figure 8](#).

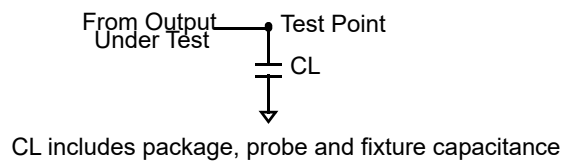

Figure 7. Load circuit for output

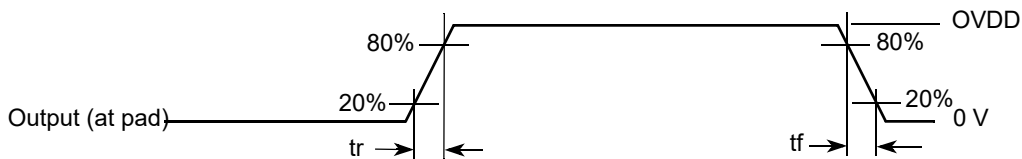

Figure 8. Output transition time waveform

3.6.1 General purpose I/O AC parameters

This section presents the I/O AC parameters for GPIO in different modes. Note that the fast or slow I/O behavior is determined by the appropriate control bits in the IOMUXC control registers.

Table 34. Maximum frequency of operation for input

Maximum frequency (MHz)	
VDD = 1.8 V, CL = 50 pF	VDD = 3.3 V, CL = 50 pF
450	440

Table 35. Maximum frequency of operation for output

Parameter			Maximum Frequency (MHz)			
			VDD = 1.8 V		VDD = 3.3 V	
dse[2:0]	sre[1:0]	Driver type	CL = 10 pF	CL = 20 pF	CL = 10 pF	CL = 20 pF
00X	0X	1x Slow Slew	150	80	120	65
00X	1X	1x Fast Slew	150	80	120	65
10X	0X	2x Slow Slew	160	90	150	80
10X	1X	2x Fast Slew	160	90	150	80
01X	0X	4x Slow Slew	200	100	180	90
01X	1X	4x Fast Slew	200	100	180	90
11X	0X	6x Slow Slew	250	130	200	100
11X	1X	6x Fast Slew	250	130	200	100

3.7 Output buffer impedance parameters

This section defines the I/O impedance parameters of the i.MX 8M Nano family of processors for the following I/O types:

NOTE

DDR I/O output driver impedance is measured with “long” transmission line of impedance Z_{tl} attached to I/O pad and incident wave launched into transmission line. R_{pu}/R_{pd} and Z_{tl} form a voltage divider that defines specific voltage of incident wave relative to OVDD. Output driver impedance is calculated from this voltage divider (see [Figure 9](#)).

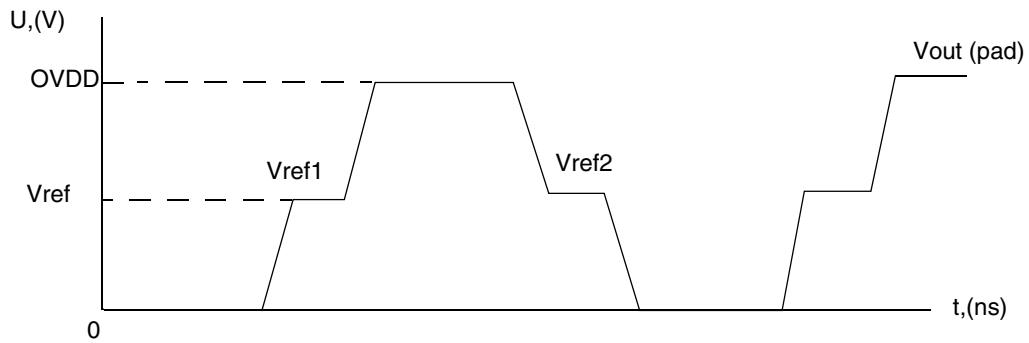
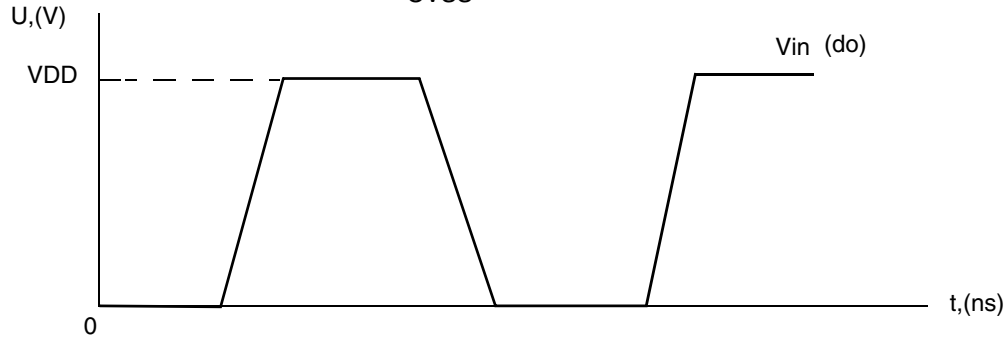
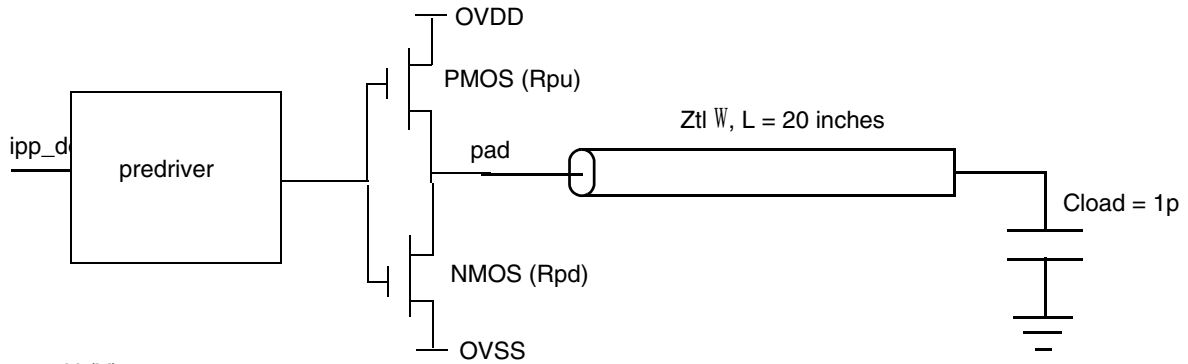

$$R_{pu} = \frac{V_{ovdd} - V_{ref1}}{V_{ref1}} \times Z_{tl}$$

$$R_{pd} = \frac{V_{ref2}}{V_{ovdd} - V_{ref2}} \times Z_{tl}$$

Figure 9. Impedance matching load for measurement

3.7.1 DDR I/O output buffer impedance

Table 36 shows DDR I/O output buffer impedance of i.MX 8M Nano family of processors.

Table 36. DDR I/O output buffer impedance

Parameter	Symbol	Test Conditions DSE (Drive Strength)	Typical			Unit
			NVCC_DRAM = 1.35 V (DDR3L)	NVCC_DRAM = 1.2 V (DDR4)	NVCC_DRAM = 1.1 V (LPDDR4)	
Output Driver Impedance	Rdrv	000000	Hi-Z	Hi-Z	Hi-Z	Ω
		000010	240	240	240	
		001000	120	120	120	
		001010	80	80	80	
		011000	60	60	60	
		011010	48	48	48	
		111000	40	40	40	
		111010	34	34	34	

Note:

1. Output driver impedance is controlled across PVTs using ZQ calibration procedure.
2. Calibration is done against 240 Ω external reference resistor.
3. Output driver impedance deviation (calibration accuracy) is ±5% (max/min impedance) across PVTs.

3.8 System modules timing

This section contains the timing and electrical parameters for the modules in each i.MX 8M Nano processor.

3.8.1 Reset timings parameters

Figure 10 shows the reset timing and Table 37 lists the timing parameters.

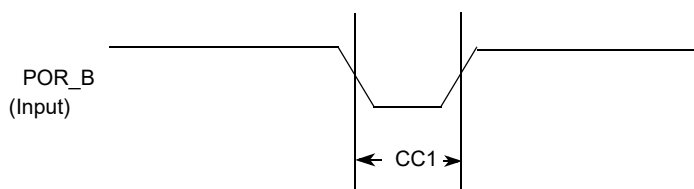

Figure 10. Reset timing diagram

Table 37. Reset timing parameters

ID	Parameter	Min	Max	Unit
CC1	Duration of POR_B to be qualified as valid.	1	—	RTC_XTALI cycle

3.8.2 WDOG Reset timing parameters

Figure 11 shows the WDOG reset timing and Table 38 lists the timing parameters.

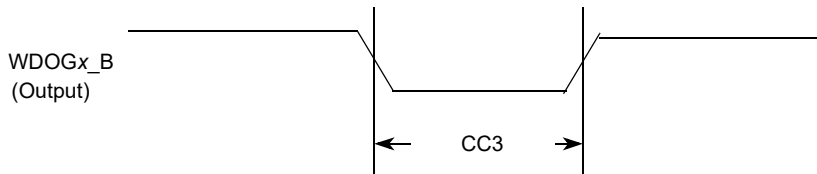

Figure 11. WDOGx_B timing diagram

Table 38. WDOGx_B timing parameters

ID	Parameter	Min	Max	Unit
CC3	Duration of WDOG1_B Assertion	1	—	RTC_XTALI cycle

NOTE

RTC_XTALI is approximately 32 kHz. RTC_XTALI cycle is one period or approximately 30 μs.

NOTE

WDOGx_B output signals (for each one of the Watchdog modules) do not have dedicated pins, but are muxed out through the IOMUX. See the IOMUXC chapter of the *i.MX 8M Nano Applications Processor Reference Manual* (IMX8MNRM) for detailed information.

3.9 External peripheral interface parameters

The following subsections provide information on external peripheral interfaces.

3.9.1 ECSPi timing parameters

This section describes the timing parameters of the ECSPi blocks. The ECSPi have separate timing parameters for master and slave modes.

3.9.1.1 ECSPi Master mode timing

Figure 12 depicts the timing of ECSPi in master mode. Table 39 lists the ECSPi master mode timing characteristics.

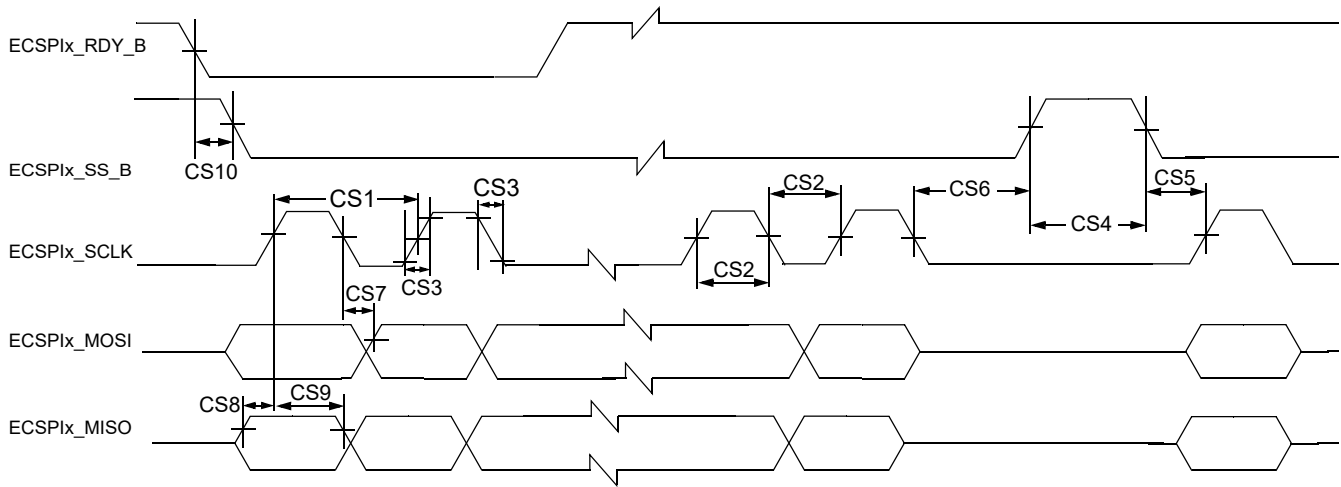

Figure 12. ECSPi Master mode timing diagram

Table 39. ECSPi Master mode timing parameters

ID	Parameter	Symbol	Min	Max	Unit
CS1	ECSPi_SCLK Cycle Time–Read ECSPi_SCLK Cycle Time–Write	t_{clk}	43 15	—	ns
CS2	ECSPi_SCLK High or Low Time–Read ECSPi_SCLK High or Low Time–Write	t_{sw}	21.5 7	—	ns
CS3	ECSPi_SCLK Rise or Fall ¹	$t_{RISE/FALL}$	—	—	ns
CS4	ECSPi_SS_B pulse width	t_{CSLH}	Half ECSPi_SCLK period	—	ns
CS5	ECSPi_SS_B Lead Time (CS setup time)	t_{SCS}	Half ECSPi_SCLK period - 4	—	ns
CS6	ECSPi_SS_B Lag Time (CS hold time)	t_{HCS}	Half ECSPi_SCLK period - 2	—	ns
CS7	ECSPi_MOSI Propagation Delay ($C_{LOAD} = 20 \text{ pF}$)	t_{PDmosi}	-1	1	ns
CS8	ECSPi_MISO Setup Time	t_{Smiso}	18	—	ns
CS9	ECSPi_MISO Hold Time	t_{Hmiso}	0	—	ns
CS10	RDY to ECSPi_SS_B Time ²	t_{SDRY}	5	—	ns

¹ See specific I/O AC parameters [Section 3.6, I/O AC parameters](#).

² SPI_RDY is sampled internally by ipg_clk and is asynchronous to all other CSPI signals.

3.9.1.2 ECSPi Slave mode timing

Figure 13 depicts the timing of ECSPi in Slave mode. Table 40 lists the ECSPi Slave mode timing characteristics.

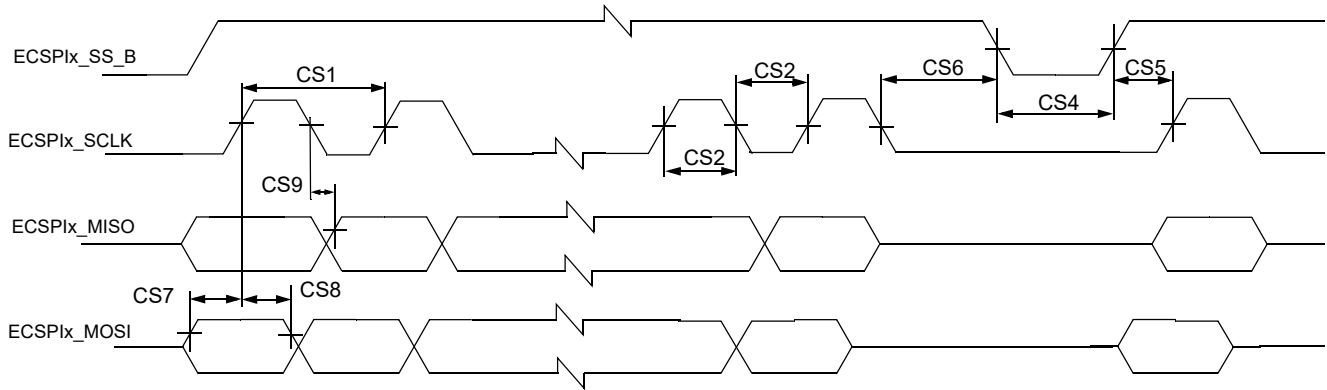

Figure 13. ECSPi Slave mode timing diagram

Table 40. ECSPi Slave mode timing parameters

ID	Parameter	Symbol	Min	Max	Unit
CS1	ECSPi_SCLK Cycle Time–Read ECSPi_SCLK Cycle Time–Write	t_{clk}	15 43	—	ns
CS2	ECSPi_SCLK High or Low Time–Read ECSPi_SCLK High or Low Time–Write	t_{sw}	7 21.5	—	ns
CS4	ECSPi_SS_B pulse width	t_{CSLH}	Half ECSPi_SCLK period	—	ns
CS5	ECSPi_SS_B Lead Time (CS setup time)	t_{SCS}	5	—	ns
CS6	ECSPi_SS_B Lag Time (CS hold time)	t_{HCS}	5	—	ns
CS7	ECSPi_MOSI Setup Time	t_{Smosi}	4	—	ns
CS8	ECSPi_MOSI Hold Time	t_{Hmosi}	4	—	ns
CS9	ECSPi_MISO Propagation Delay ($C_{LOAD} = 20\text{ pF}$)	t_{PDmiso}	4	19	ns

3.9.2 Ultra-high-speed SD/SDIO/MMC host interface (uSDHC) AC timing

This section describes the electrical information of the uSDHC, which includes SD/eMMC 5.1 (single data rate) timing, eMMC 5.1/SD3.0 (dual data rate) AC timing, and SDR50/SDR104 AC timing.

3.9.2.1 SD/eMMC5.1 (single data rate) AC timing

Figure 14 depicts the timing of SD3.0/eMMC5.1 (SDR), and Table 41 lists the SD3.0/eMMC5.1 (SDR) timing characteristics.

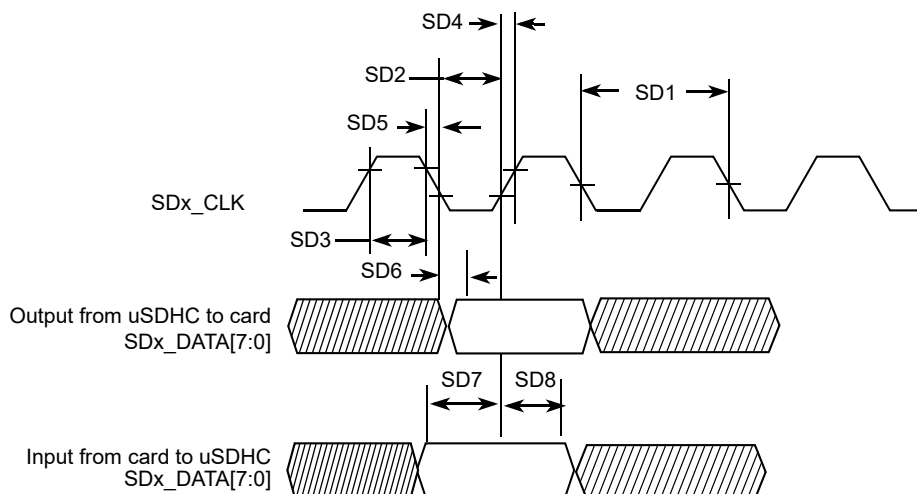

Figure 14. SD3.0/eMMC5.1 (SDR) timing

Table 41. SD3.0/eMMC5.1 (SDR) interface timing specification

ID	Parameter	Symbols	Min	Max	Unit
Card Input Clock					
SD1	Clock Frequency (Low Speed)	f_{PP}^1	0	400	kHz
	Clock Frequency (SD/SDIO Full Speed/High Speed)	f_{PP}^2	0	25/50	MHz
	Clock Frequency (MMC Full Speed/High Speed)	f_{PP}^3	0	20/52	MHz
	Clock Frequency (Identification Mode)	f_{OD}	100	400	kHz
SD2	Clock Low Time	t_{WL}	7	—	ns
SD3	Clock High Time	t_{WH}	7	—	ns
SD4	Clock Rise Time	t_{TLH}	—	3	ns
SD5	Clock Fall Time	t_{THL}	—	3	ns
uSDHC Output/Card Inputs SD_CMD, SDx_DATAx (Reference to CLK)					
SD6	uSDHC Output Delay	t_{OD}	6.6	3.6	ns

Table 41. SD3.0/eMMC5.1 (SDR) interface timing specification (continued)

ID	Parameter	Symbols	Min	Max	Unit
uSDHC Input/Card Outputs SD_CMD, SDx_DATAx (Reference to CLK)					
SD7	uSDHC Input Setup Time	t_{ISU}	2.5	—	ns
SD8	uSDHC Input Hold Time ⁴	t_{IH}	1.5	—	ns

- ¹ In Low-Speed mode, card clock must be lower than 400 kHz, voltage ranges from 2.7 to 3.6 V.
- ² In Normal (Full) -Speed mode for SD/SDIO card, clock frequency can be any value between 0 – 25 MHz. In High-speed mode, clock frequency can be any value between 0 – 50 MHz.
- ³ In Normal (Full) -Speed mode for MMC card, clock frequency can be any value between 0 – 20 MHz. In High-speed mode, clock frequency can be any value between 0 – 52 MHz.
- ⁴ To satisfy hold timing, the delay difference between clock input and cmd/data input must not exceed 2 ns.

3.9.2.2 eMMC5.1/SD3.0 (dual data rate) AC timing

Figure 15 depicts the timing of eMMC5.1/SD3.0 (DDR). Table 42 lists the eMMC5.1/SD3.0 (DDR) timing characteristics. Be aware that only DATA is sampled on both edges of the clock (not applicable to CMD).

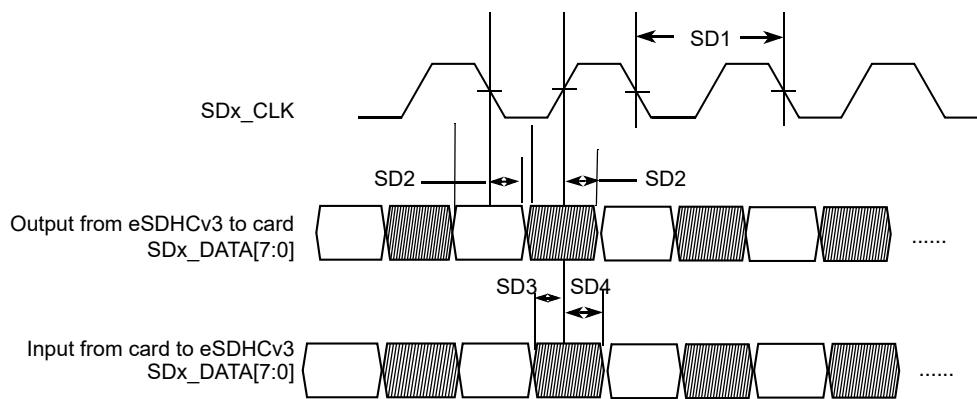

Figure 15. eMMC5.1/SD3.0 (DDR) timing

Table 42. eMMC5.1/SD3.0 (DDR) interface timing specification

ID	Parameter	Symbols	Min	Max	Unit
Card Input Clock					
SD1	Clock Frequency (eMMC5.1 DDR)	f_{PP}	0	52	MHz
SD1	Clock Frequency (SD3.0 DDR)	f_{PP}	0	50	MHz
uSDHC Output / Card Inputs SD_CMD, SDx_DATAx (Reference to CLK)					
SD2	uSDHC Output Delay	t_{OD}	2.7	6.9	ns
uSDHC Input / Card Outputs SD_CMD, SDx_DATAx (Reference to CLK)					

Table 42. eMMC5.1/SD3.0 (DDR) interface timing specification (continued)

ID	Parameter	Symbols	Min	Max	Unit
SD3	uSDHC Input Setup Time	t_{ISU}	2.4	—	ns
SD4	uSDHC Input Hold Time	t_{IH}	1.3	—	ns

3.9.2.3 HS400 DDR AC timing

Figure 16 depicts the timing of HS400 mode, and Table 43 lists the HS400 timing characteristics. Be aware that only data is sampled on both edges of the clock (not applicable to CMD). The CMD input/output timing for HS400 mode is the same as CMD input/output timing for SDR104 mode. Check SD5, SD6, and SD7 parameters in Table 45 SDR50/SDR104 Interface Timing Specification for CMD input/output timing for HS400 mode.

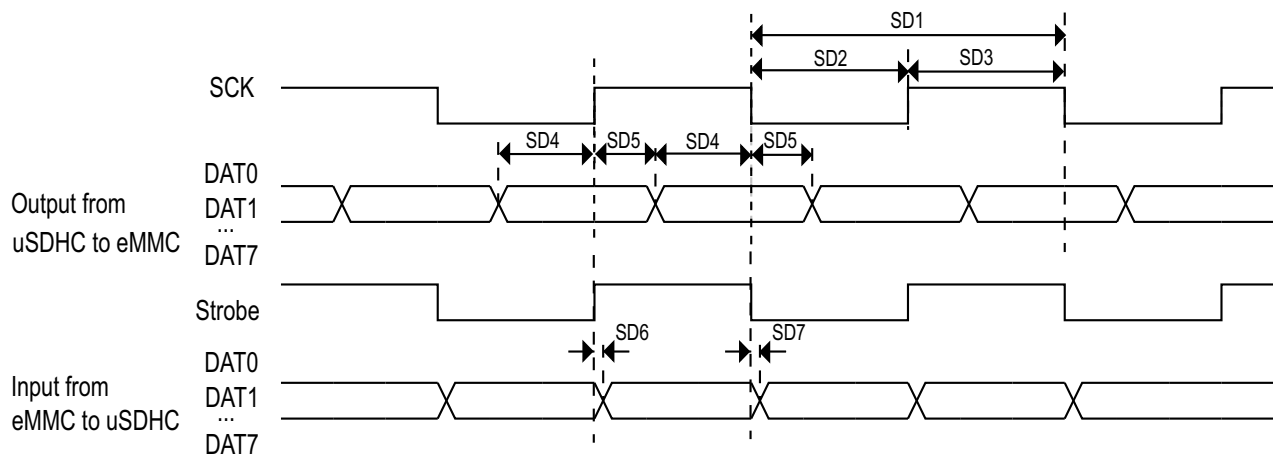

Figure 16. HS400 Mode timing

Table 43. HS400 interface timing specification

ID	Parameter	Symbols	Min	Max	Unit
Card Input Clock					
SD1	Clock frequency	f_{PP}	0	200	MHz
SD2	Clock low time	t_{CL}	$0.46 \times t_{CLK}$	$0.54 \times t_{CLK}$	ns
SD3	Clock high time	t_{CH}	$0.46 \times t_{CLK}$	$0.54 \times t_{CLK}$	ns
uSDHC Output/Card Inputs DAT (Reference to SCK)					
SD4	Output skew from data of edge of SCK	t_{OSkew1}	0.45	—	ns
SD5	Output skew from edge of SCK to data	t_{OSkew2}	0.45	—	ns
uSDHC Input/Card Outputs DAT (Reference to Strobe)					

Table 43. HS400 interface timing specification (continued)

ID	Parameter	Symbols	Min	Max	Unit
SD6	uSDHC input skew	t_{RQ}	—	0.45	ns
SD7	uSDHC hold skew	t_{RQH}	—	0.45	ns

3.9.2.4 HS200 Mode AC timing

Figure 17 depicts the timing of HS200 mode, and Table 44 lists the HS200 timing characteristics.

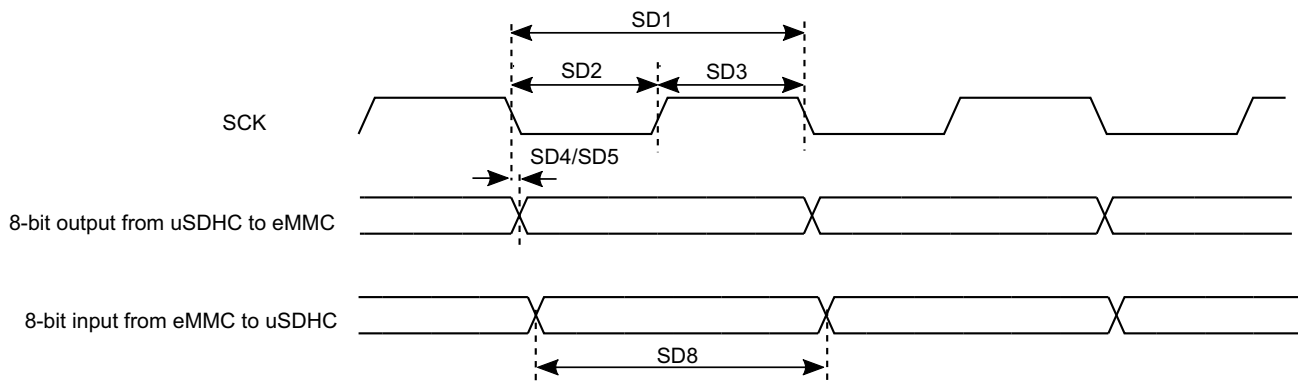

Figure 17. HS200 timing

Table 44. HS200 interface timing specification

ID	Parameter	Symbols	Min	Max	Unit
Card Input Clock					
SD1	Clock Frequency Period	t_{CLK}	5.0	—	ns
SD2	Clock Low Time	t_{CL}	$0.3 \times t_{CLK}$	$0.7 \times t_{CLK}$	ns
SD3	Clock High Time	t_{CH}	$0.3 \times t_{CLK}$	$0.7 \times t_{CLK}$	ns
uSDHC Output/Card Inputs SD_CMD, SDx_DATAx in HS200 (Reference to CLK)					
SD5	uSDHC Output Delay	t_{OD}	-1.6	1	ns
uSDHC Input/Card Outputs SD_CMD, SDx_DATAx in HS200 (Reference to CLK)¹					
SD8	uSDHC Output Data Window	t_{ODW}	$0.5 \times t_{CLK}$	—	ns

¹ HS200 is for 8 bits while SDR104 is for 4 bits.

3.9.2.5 SDR50/SDR104 AC timing

Figure 18 depicts the timing of SDR50/SDR104, and Table 45 lists the SDR50/SDR104 timing characteristics.

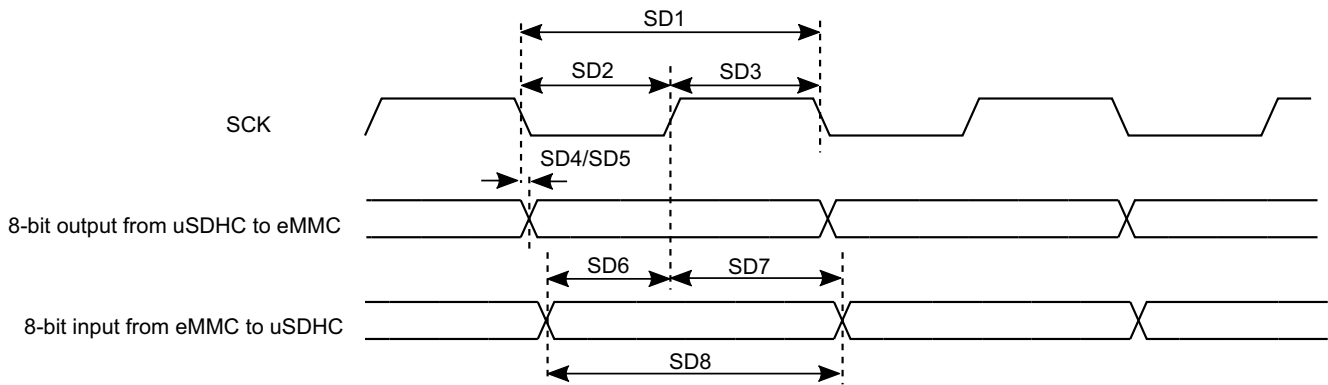

Figure 18. SDR50/SDR104 timing

Table 45. SDR50/SDR104 interface timing specification

ID	Parameter	Symbols	Min	Max	Unit
Card Input Clock					
SD1	Clock Frequency Period	t_{CLK}	5	—	ns
SD2	Clock Low Time	t_{CL}	$0.46 \times t_{CLK}$	$0.54 \times t_{CLK}$	ns
SD3	Clock High Time	t_{CH}	$0.46 \times t_{CLK}$	$0.54 \times t_{CLK}$	ns
uSDHC Output/Card Inputs SD_CMD, SDx_DATAx in SDR50 (Reference to CLK)					
SD4	uSDHC Output Delay	t_{OD}	-3	1	ns
uSDHC Output/Card Inputs SD_CMD, SDx_DATAx in SDR104 (Reference to CLK)					
SD5	uSDHC Output Delay	t_{OD}	-1.6	1	ns
uSDHC Input/Card Outputs SD_CMD, SDx_DATAx in SDR50 (Reference to CLK)					
SD6	uSDHC Input Setup Time	t_{ISU}	2.4	—	ns
SD7	uSDHC Input Hold Time	t_{IH}	1.4	—	ns
uSDHC Input/Card Outputs SD_CMD, SDx_DATAx in SDR104 (Reference to CLK)¹					
SD8	uSDHC Output Data Window	t_{ODW}	$0.5 \times t_{CLK}$	—	ns

¹ Data window in SDR100 mode is variable.

3.9.2.6 Bus operation condition for 3.3 V and 1.8 V signaling

Signaling level of SD/eMMC4.5/5.0/5.1 can be 1.8 V or 3.3 V depending on the working mode. The DC parameters for the NVCC_SD1, NVCC_SD2 and NVCC_SD3 supplies are identical to those shown in Table 32, "GPIO DC parameters," on page 35.

3.9.3 Ethernet controller (ENET) AC electrical specifications

The following timing specs are defined at the chip I/O pin and must be translated appropriately to arrive at timing specs/constraints for the physical interface.

Table 46. ENET signal mapping

Pad name	RGMII/RMII signal	Mode	Alt mode	Direction	Comments
ENET_MDC	MDC	RMII/RGMII	ALT0	O	—
ENET_MDIO	MDIO	RMII/RGMII	ALT0	I/O	—
ENET_TD3	TX_D3	RGMII	ALT0	O	Only used for RGMII
ENET_TD2	REF_CLK	RMII	ALT1	I/O	Used as RMII clock and RGMII data, there are two RMII clock schemes. <ul style="list-style-type: none"> • MAC generate output 50M reference clock for PHY, and MAC also use this 50M clock. • MAC use external 50M clock. For RMII—ENET_TD2 functions as RMII REF_CLK when configured in the ALT1 mode.
	TX_D2	RGMII	ALT0		
ENET_TD1	TX_D1	RMII/RGMII	ALT0	O	—
ENET_TD0	TX_D0	RMII/RGMII	ALT0	O	—
ENET_TX_CTL	TX_EN	RMII	ALT0	O	—
	TX_CTL	RGMII	ALT0		
ENET_TXC	TX_ER	RMII	ALT1	O	For RMII—ENET_TXC functions as RMII TX_ER when configured in the ALT1 mode. For RGMII—ENET_TXC functions as RGMII TXC when configured in the ALT0 mode.
	TXC	RGMII	ALT0		
ENET_RX_CTL	RX_EN (CRS_DV)	RMII	ALT0	I	—
	RX_CTL	RGMII	ALT0		
ENET_RXC	RX_ER	RMII	ALT1	I	For RMII—ENET_RXC functions as RMII RX_ER when configured in the ALT1 mode. For RGMII—ENET_RXC functions as RGMII RXC when configured in the ALT0 mode.
	RXC	RGMII	ALT0		
ENET_RD0	RX_D0	RMII/RGMII	ALT0	I	—
ENET_RD1	RX_D1	RMII/RGMII	ALT0	I	—
ENET_RD2	RX_D2	RGMII	ALT0	I	—
ENET_RD3	RX_D3	RGMII	ALT0	I	—
GPIO1_IO06	MDC	RMII/RGMII	ALT1	O	—
GPIO1_IO07	MDIO	RMII/RGMII	ALT1	I/O	—
I2C1_SCL	MDC	RMII/RGMII	ALT1	O	—
I2C1_SDA	MDIO	RMII/RGMII	ALT1	I/O	—

Table 46. ENET signal mapping (continued)

Pad name	RGII/RMII signal	Mode	Alt mode	Direction	Comments
GPIO1_IO08	1588_EVENT0_IN	RMII/RGMII	ALT1	I	Capture/compare block input/output event bus signal. When configured for capture and a rising edge is detected, the current timer value is latched and transferred into the corresponding ENET_TCCRn register for inspection by software. When configured for compare, the corresponding signal 1588_EVENT is asserted for one cycle when the timer reaches the compare value programmed in register ENET_TCCRn. An interrupt or DMA request can be triggered if the corresponding bit in ENET_TCSRn[TIE] or ENET_TCSRn[TDRE] is set.
GPIO1_IO09	1588_EVENT0_OUT	RMII/RGMII	ALT1	O	—
I2C2_SCL	1588_EVENT1_IN	RMII/RGMII	ALT1	I	—
I2C2_SDA	1588_EVENT1_OUT	RMII/RGMII	ALT1	O	—
GPIO1_IO00	ENET_PHY_REF_CLK_ROOT	RGMII	ALT1	O	Reference clock for PHY.
SD1_CLK	MDC	RMII	ALT1	O	—
SD1_CMD	MDIO	RMII	ALT1	I/O	—
SD1_DATA0	TX_D1	RMII	ALT1	O	—
SD1_DATA1	TX_D0	RMII	ALT1	O	—
SD1_DATA2	RX_D0	RMII	ALT1	I	—
SD1_DATA3	RX_D1	RMII	ALT1	I	—
SD1_DATA4	TX_EN	RMII	ALT1	O	—
SD1_DATA5	TX_ER	RMII	ALT1	O	For RMII—SD1_DATA5 functions as RMII TX_ER when configured in the ALT1 mode.
SD1_DATA6	RX_EN (CRS_DV)	RMII	ALT1	I	—
SD1_DATA7	RX_ER	RMII	ALT1	I	For RMII—SD1_DATA7 functions as RMII RX_ER when configured in the ALT1 mode.
SD1_RESET_B	REF_CLK	RMII	ALT1	O	For RMII—SD1_RESET_B functions as RMII REF_CLK when configured in the ALT1 mode.

3.9.3.1 RMII mode timing

Figure 19 shows RMII mode timings. Table 47 describes the timing parameters (M16–M21) shown in the figure.

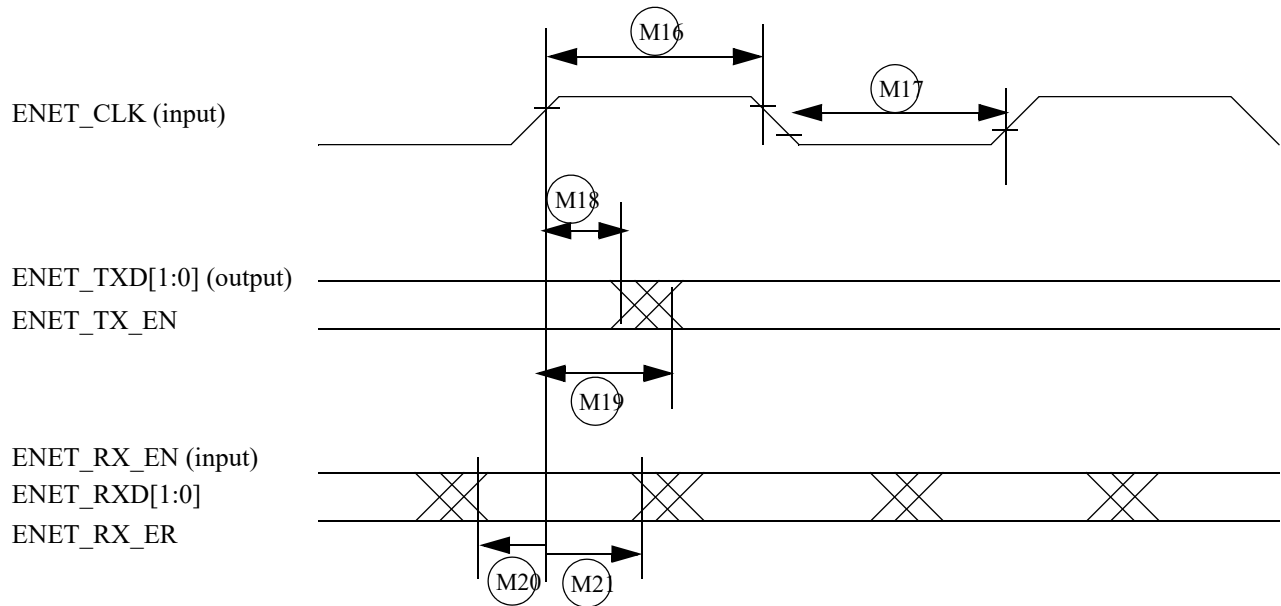

Figure 19. RMII mode signal timing diagram

Table 47. RMII signal timing

ID	Characteristic	Min.	Max.	Unit
M16	ENET_CLK pulse width high	35%	65%	ENET_CLK period
M17	ENET_CLK pulse width low	35%	65%	ENET_CLK period
M18	ENET_CLK to ENET_TXD[1:0], ENET_TXD invalid	4	—	ns
M19	ENET_CLK to ENET_TXD[1:0], ENET_TXD valid	—	15	ns
M20	ENET_RXD[1:0], ENET_RX_EN, ENET_RX_ER to ENET_CLK setup	4	—	ns
M21	ENET_CLK to ENET_RXD[1:0], ENET_RX_EN, ENET_RX_ER hold	2	—	ns

3.9.3.2 RGMII signal switching specifications

The following timing specifications meet the requirements for RGMII interfaces for a range of transceiver devices.

Table 48. RGMII signal switching specifications¹

Symbol	Description	Min.	Max.	Unit
T_{cyc}^2	Clock cycle duration	7.2	8.8	ns
T_{skewT}^3	Data to clock output skew at transmitter	-500	500	ps
T_{skewR}^3	Data to clock input skew at receiver	1	2.6	ns
Duty_G ⁴	Duty cycle for Gigabit	45	55	%
Duty_T ⁴	Duty cycle for 10/100T	40	60	%
Tr/Tf	Rise/fall time (20–80%)	—	0.75	ns

¹ The timings assume the following configuration:

DDR_SEL = (11)b

DSE (drive-strength) = (111)b

² For 10 Mbps and 100 Mbps, T_{cyc} will scale to 400 ns \pm 40 ns and 40 ns \pm 4 ns respectively.

³ For all versions of RGMII prior to 2.0; this implies that PC board design will require clocks to be routed such that an additional trace delay of greater than 1.5 ns and less than 2.0 ns will be added to the associated clock signal. For 10/100, the Max value is unspecified.

⁴ Duty cycle may be stretched/shrunk during speed changes or while transitioning to a received packet's clock domain as long as minimum duty cycle is not violated and stretching occurs for no more than three T_{cyc} of the lowest speed transitioned between.

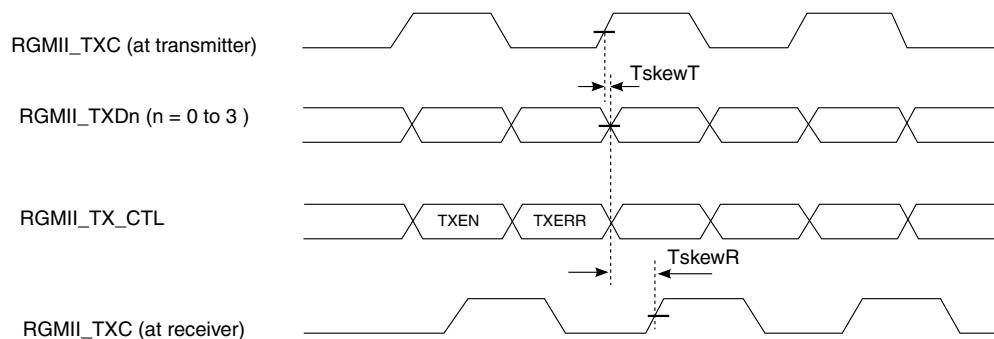
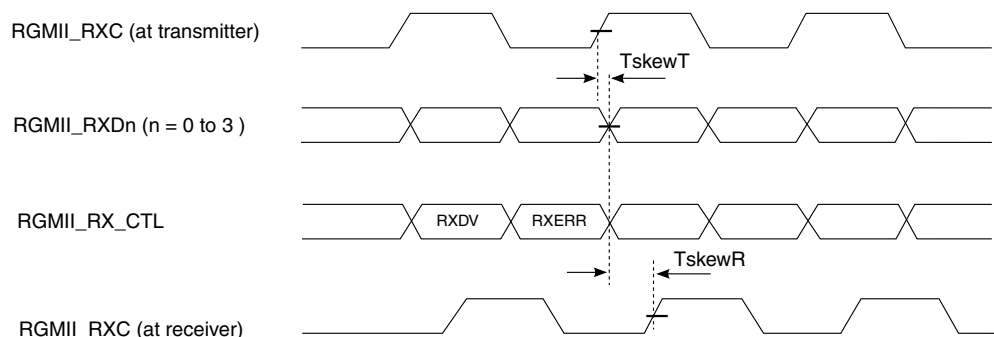
**Figure 20. RGMII transmit signal timing diagram original****Figure 21. RGMII receive signal timing diagram original**

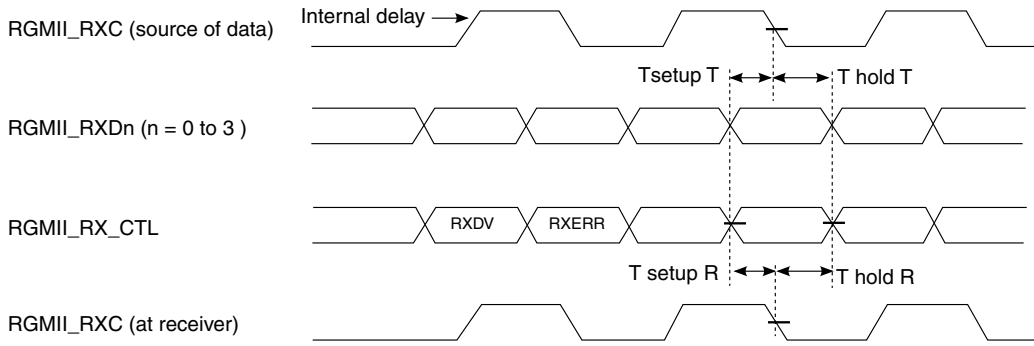

Figure 22. RGMII receive signal timing diagram with internal delay

3.9.4 General-purpose media interface (GPMI) timing

The i.MX 8M Nano GPMI controller is a flexible interface NAND Flash controller with 8-bit data width, up to 200 MB/s I/O speed and individual chip select.

It supports Asynchronous Timing mode, Source Synchronous Timing mode and Toggle Timing mode separately, as described in the following subsections.

3.9.4.1 Asynchronous mode AC timing (ONFI 1.0 compatible)

Asynchronous mode AC timings are provided as multiplications of the clock cycle and fixed delay. The maximum I/O speed of GPMI in Asynchronous mode is about 50 MB/s. Figure 23 through Figure 26 depicts the relative timing between GPMI signals at the module level for different operations under Asynchronous mode. Table 49 describes the timing parameters (NF1–NF17) that are shown in the figures.

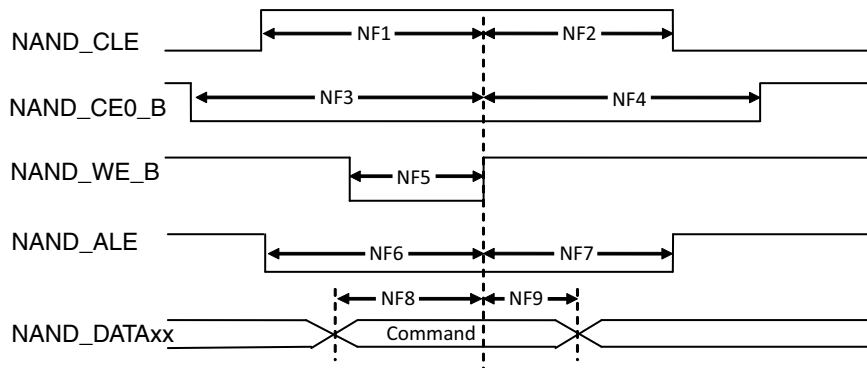

Figure 23. Command Latch cycle timing diagram

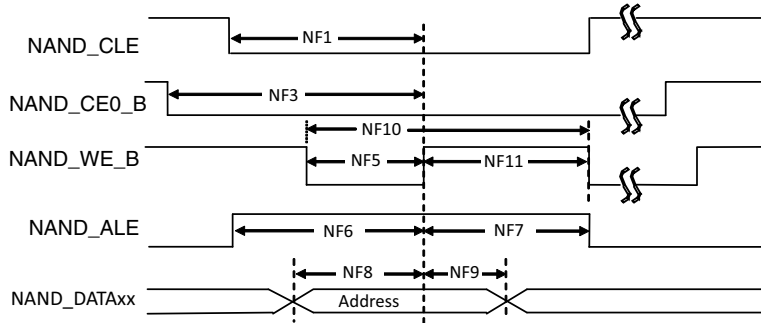

Figure 24. Address Latch cycle timing diagram

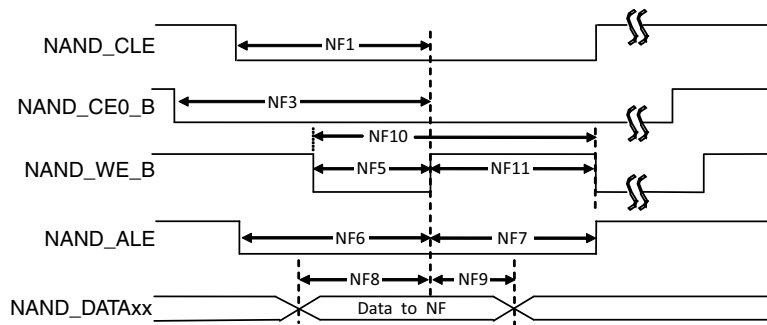

Figure 25. Write Data Latch cycle timing diagram

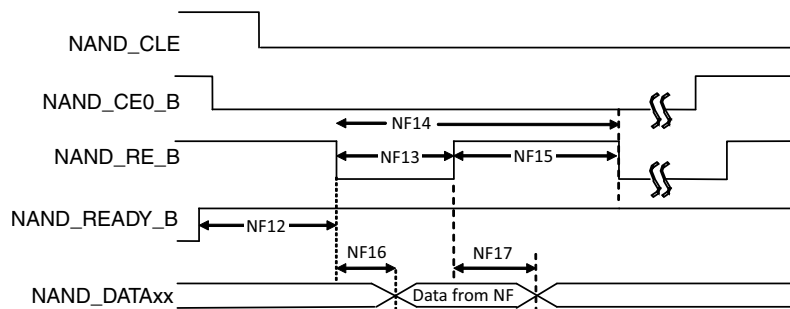

Figure 26. Read Data Latch cycle timing diagram (Non-EDO Mode)

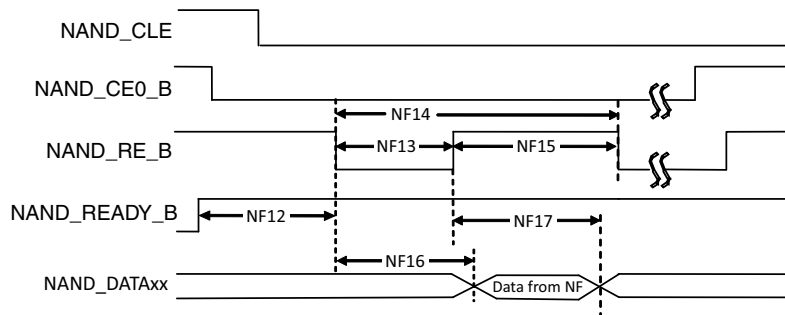

Figure 27. Read Data Latch cycle timing diagram (EDO mode)

Table 49. Asynchronous mode timing parameters¹

ID	Parameter	Symbol	Timing T = GPMI Clock Cycle		Unit
			Min.	Max.	
NF1	NAND_CLE setup time	tCLS	$(AS + DS) \times T - 0.12$ [see notes ^{2,3}]		ns
NF2	NAND_CLE hold time	tCLH	$DH \times T - 0.72$ [see note ²]		ns
NF3	NAND_CE0_B setup time	tCS	$(AS + DS + 1) \times T$ [see notes ^{3,2}]		ns
NF4	NAND_CE0_B hold time	tCH	$(DH+1) \times T - 1$ [see note ²]		ns
NF5	NAND_WE_B pulse width	tWP	$DS \times T$ [see note ²]		ns
NF6	NAND_ALE setup time	tALS	$(AS + DS) \times T - 0.49$ [see notes ^{3,2}]		ns
NF7	NAND_ALE hold time	tALH	$DH \times T - 0.42$ [see note ²]		ns
NF8	Data setup time	tDS	$DH \times T - 0.26$ [see note ²]		ns
NF9	Data hold time	tDH	$DH \times T - 1.37$ [see note ²]		ns
NF10	Write cycle time	tWC	$(DS + DH) \times T$ [see note ²]		ns
NF11	NAND_WE_B hold time	tWH	$DH \times T$ [see note ²]		ns
NF12	Ready to NAND_RE_B low	tRR ⁴	$(AS + 2) \times T$ [see ^{3,2}]	—	ns
NF13	NAND_RE_B pulse width	tRP	$DS \times T$ [see note ²]		ns
NF14	READ cycle time	tRC	$(DS + DH) \times T$ [see note ²]		ns
NF15	NAND_RE_B high hold time	tREH	$DS \times T$ [see note ²]		ns
NF16	Data setup on read	tDSR	—	$(DS \times T - 0.67)/18.38$ [see notes ^{5,6}]	ns
NF17	Data hold on read	tDHR	0.82/11.83 [see notes ^{5,6}]	—	ns

¹ GPMI's Asynchronous mode output timing can be controlled by the module's internal registers HW_GPMI_TIMING0_ADDRESS_SETUP, HW_GPMI_TIMING0_DATA_SETUP, and HW_GPMI_TIMING0_DATA_HOLD. This AC timing depends on these registers settings. In the table, AS/DS/DH represents each of these settings.

² AS minimum value can be 0, while DS/DH minimum value is 1.

³ T = GPMI clock period -0.075 ns (half of maximum p-p jitter).

⁴ NF12 is guaranteed by the design.

⁵ Non-EDO mode.

⁶ EDO mode, GPMI clock \approx 100 MHz
(AS=DS=DH=1, GPMI_CTL1 [RDN_DELAY] = 8, GPMI_CTL1 [HALF_PERIOD] = 0).

In EDO mode (Figure 26), NF16/NF17 are different from the definition in non-EDO mode (Figure 25). They are called tREA/tRHOH (RE# access time/RE# HIGH to output hold). The typical values for them are 16 ns (max for tREA)/15 ns (min for tRHOH) at 50 MB/s EDO mode. In EDO mode, GPMI samples NAND_DATAxx at the rising edge of delayed NAND_RE_B provided by an internal DPLL. The delay value can be controlled by GPMI_CTRL1.RDN_DELAY (see the GPMI chapter of the *i.MX 8M Nano Applications Processor Reference Manual* [IMX8MNRM]). The typical value of this control register is 0x8 at 50 MT/s EDO mode. But if the board delay is big enough and cannot be ignored, the delay value should be made larger to compensate the board delay.

3.9.4.2 Source synchronous mode AC timing (ONFI 2.x compatible)

Figure 28 to Figure 30 show the write and read timing of Source Synchronous mode.

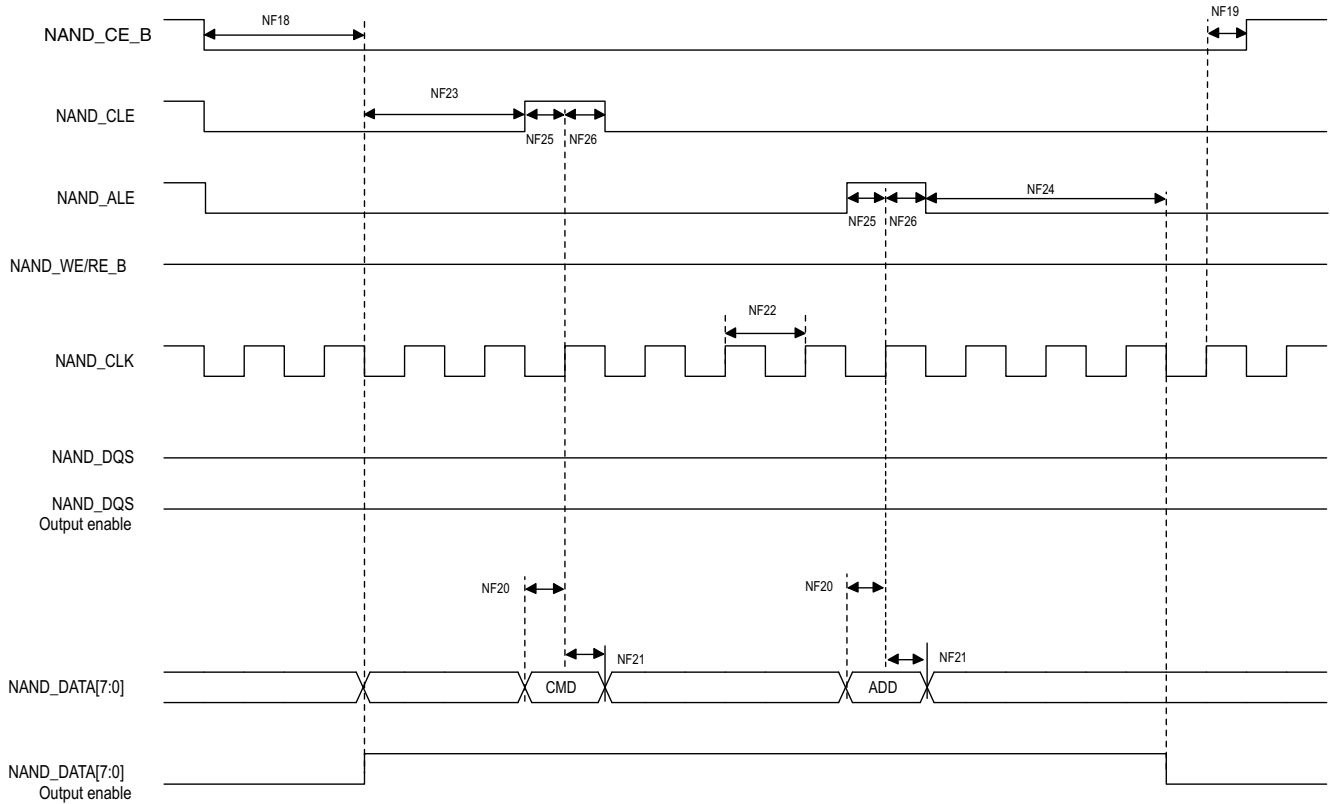

Figure 28. Source Synchronous mode command and address timing diagram

Electrical characteristics

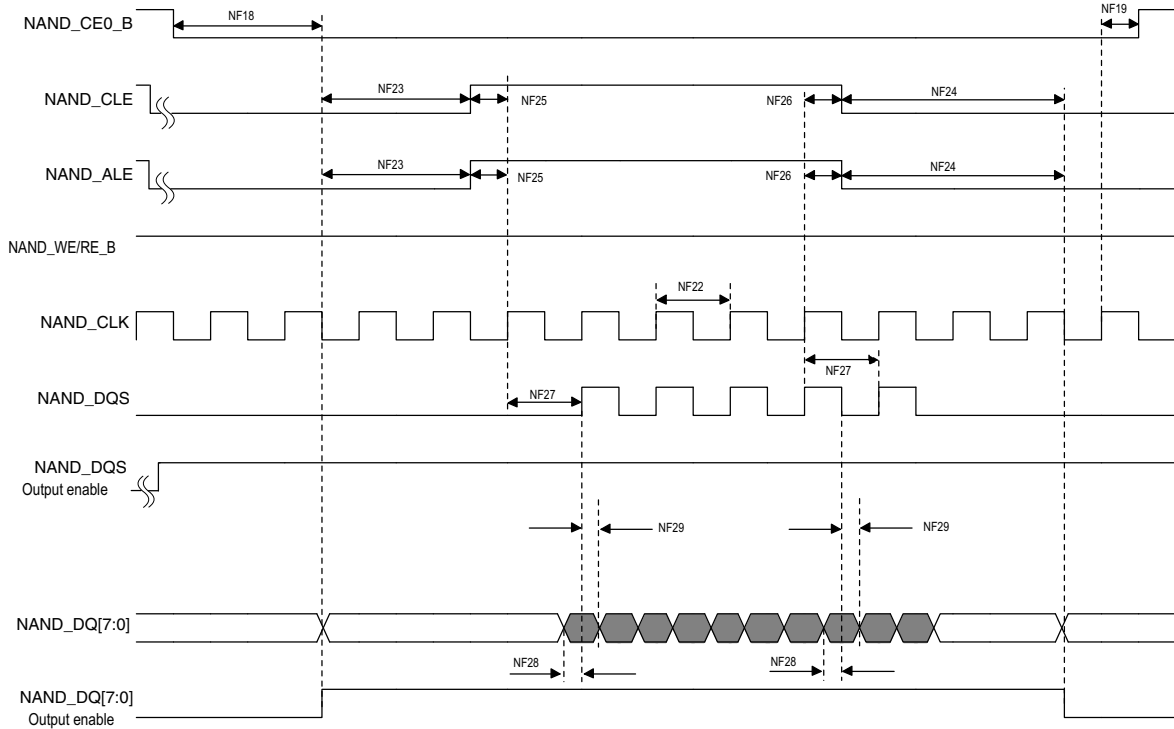

Figure 29. Source Synchronous mode data write timing diagram

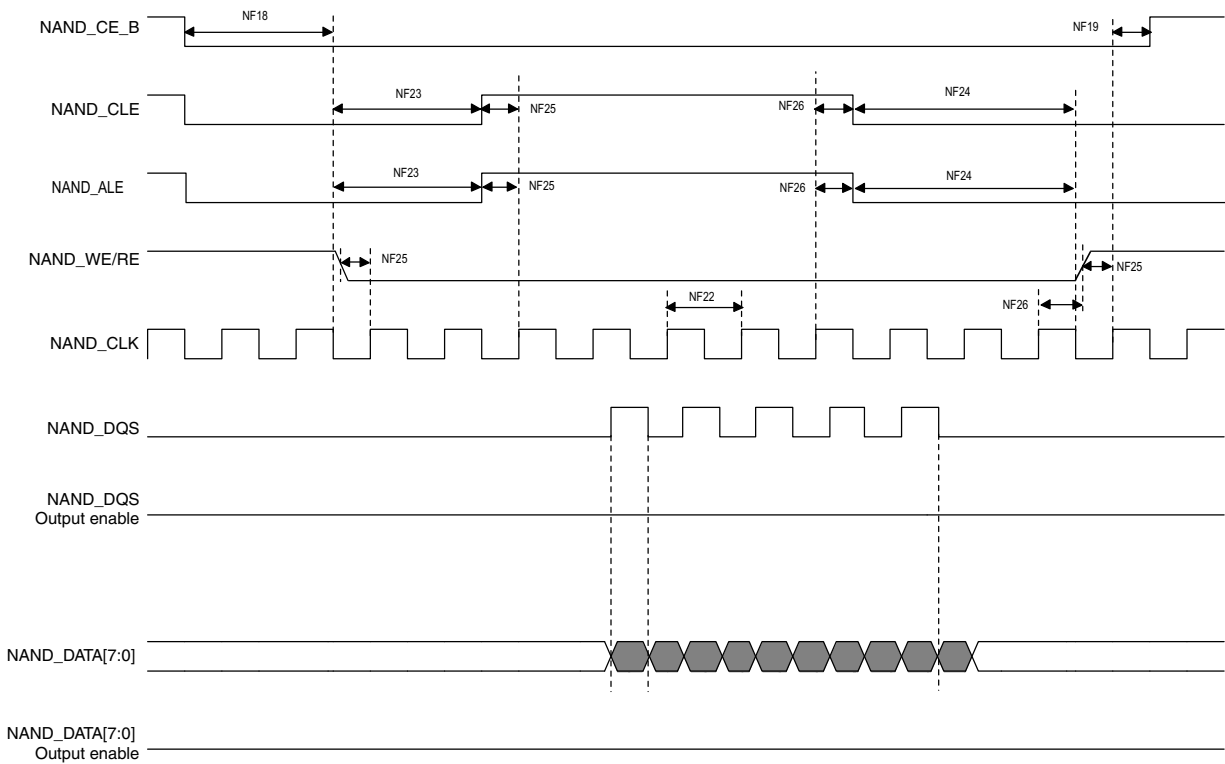

Figure 30. Source Synchronous mode data read timing diagram

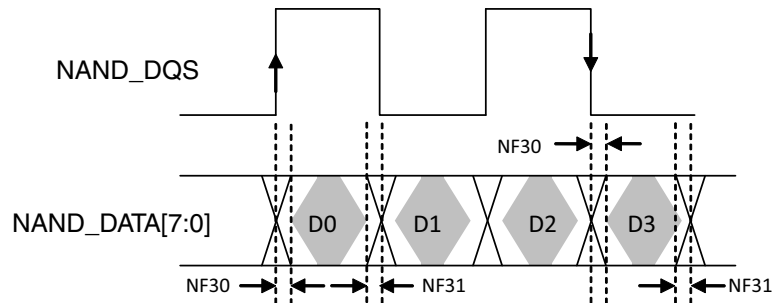

Figure 31. NAND_DQS/NAND_DQ read valid window

Table 50. Source Synchronous mode timing parameters¹

ID	Parameter	Symbol	Timing T = GPMI Clock Cycle		Unit
			Min.	Max.	
NF18	NAND_CEO_B access time	tCE	CE_DELAY × T - 0.79 [see note ²]		ns
NF19	NAND_CEO_B hold time	tCH	0.5 × tCK - 0.63 [see note ²]		ns
NF20	Command/address NAND_DATAxx setup time	tCAS	0.5 × tCK - 0.05		ns
NF21	Command/address NAND_DATAxx hold time	tCAH	0.5 × tCK - 1.23		ns
NF22	clock period	tCK	—		ns
NF23	preamble delay	tPRE	PRE_DELAY × T - 0.29 [see note ²]		ns
NF24	postamble delay	tPOST	POST_DELAY × T - 0.78 [see note ²]		ns
NF25	NAND_CLE and NAND_ALE setup time	tCALS	0.5 × tCK - 0.86		ns
NF26	NAND_CLE and NAND_ALE hold time	tCALH	0.5 × tCK - 0.37		ns
NF27	NAND_CLK to first NAND_DQS latching transition	tDQSS	T - 0.41 [see note ²]		ns
NF28	Data write setup	—	0.25 × tCK - 0.35		
NF29	Data write hold	—	0.25 × tCK - 0.85		
NF30	NAND_DQS/NAND_DQ read setup skew	—	—	2.06	
NF31	NAND_DQS/NAND_DQ read hold skew	—	—	1.95	

¹ GPMI's Source Synchronous mode output timing can be controlled by the module's internal registers GPMI_TIMING2_CE_DELAY, GPMI_TIMING2_PREAMBLE_DELAY, GPMI_TIMING2_POST_DELAY. This AC timing depends on these registers settings. In the table, CE_DELAY/PRE_DELAY/POST_DELAY represents each of these settings.

² T = tCK(GPMI clock period) - 0.075 ns (half of maximum p-p jitter).

For DDR Source Synchronous mode, Figure 31 shows the timing diagram of NAND_DQS/NAND_DATAxx read valid window. The typical value of tDQSQ is 0.85 ns (max) and 1 ns (max) for tQHS at 200 MB/s. GPMI will sample NAND_DATA[7:0] at both rising and falling edge of an delayed NAND_DQS signal, which can be provided by an internal DPLL. The delay value can be controlled by GPMI register GPMI_READ_DDR_DLL_CTRL.SLV_DLY_TARGET (see the GPMI chapter of the *i.MX 8M Nano Applications Processor Reference Manual* [IMX8MNRM]). Generally, the typical delay value of this register is equal to 0x7 which means 1/4 clock cycle delay expected. But if the board delay is big enough and cannot be ignored, the delay value should be made larger to compensate the board delay.

3.9.4.3 ONFI NV-DDR2 mode (ONFI 3.2 compatible)

3.9.4.3.1 Command and address timing

ONFI 3.2 mode command and address timing is the same as ONFI 1.0 compatible Async mode AC timing. See [Section 3.9.4.1, Asynchronous mode AC timing \(ONFI 1.0 compatible\)](#), for details.

3.9.4.3.2 Read and write timing

ONFI 3.2 mode read and write timing is the same as Toggle mode AC timing. See [Section 3.9.4.4, Toggle mode AC Timing](#), for details.

3.9.4.4 Toggle mode AC Timing

3.9.4.4.1 Command and address timing

NOTE

Toggle mode command and address timing is the same as ONFI 1.0 compatible Asynchronous mode AC timing. See [Section 3.9.4.1, Asynchronous mode AC timing \(ONFI 1.0 compatible\)](#), for details.

3.9.4.4.2 Read and write timing

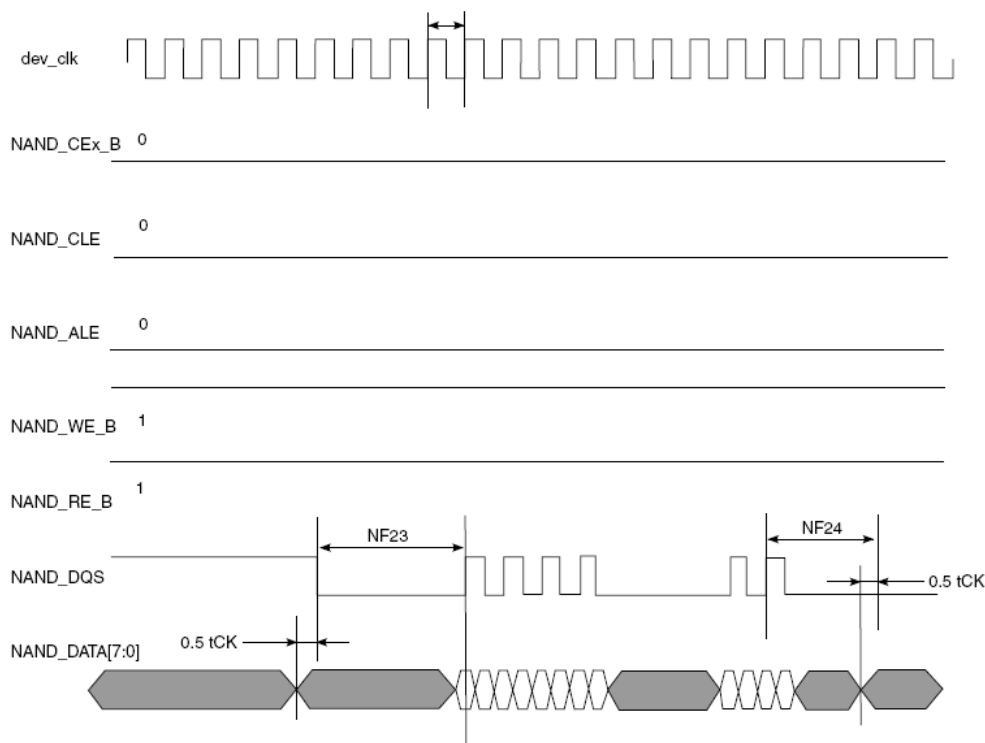

Figure 32. Toggle mode data write timing

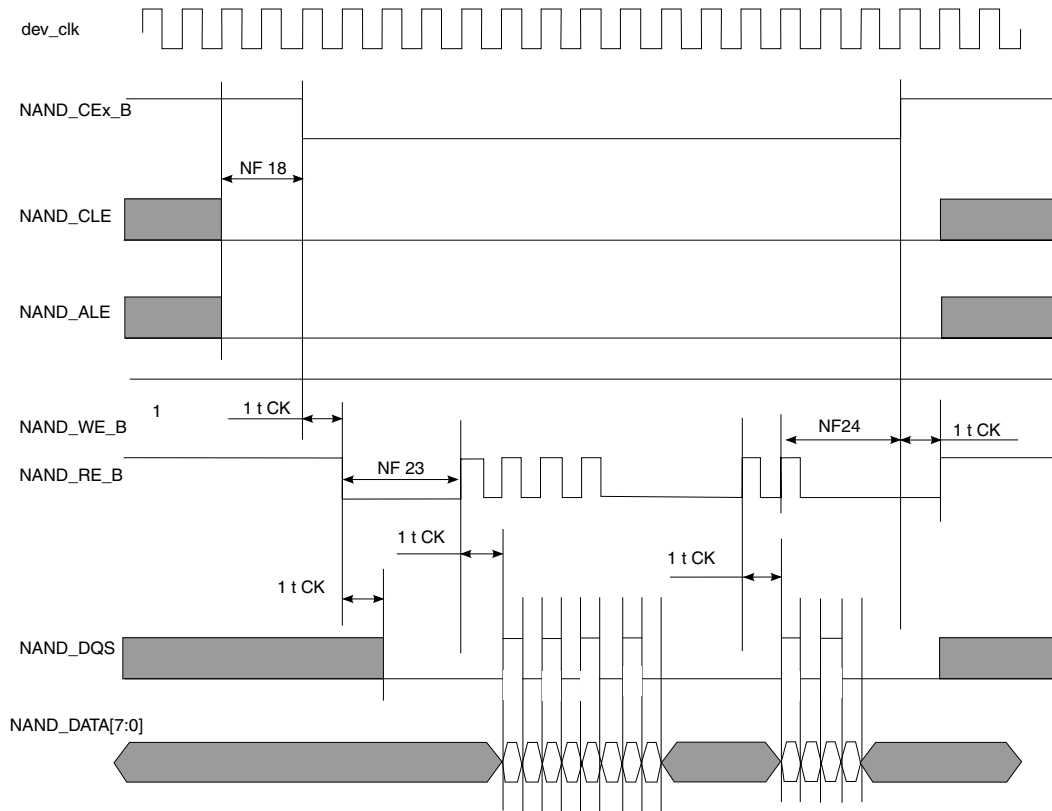

Figure 33. Toggle mode data read timing

Table 51. Toggle mode timing parameters

ID	Parameter	Symbol	Timing T = GPML Clock Cycle		Unit
			Min.	Max.	
NF1	NAND_CLE setup time	tCLS	$(AS + DS) \times T - 0.12$ [see note ^{1,2}]		
NF2	NAND_CLE hold time	tCLH	$DH \times T - 0.72$ [see note ²]		
NF3	NAND_CE0_B setup time	tCS	$(AS + DS) \times T - 0.58$ [see notes ²]		
NF4	NAND_CE0_B hold time	tCH	$DH \times T - 1$ [see note ²]		
NF5	NAND_WE_B pulse width	tWP	$DS \times T$ [see note ²]		
NF6	NAND_ALE setup time	tALS	$(AS + DS) \times T - 0.49$ [see notes ²]		
NF7	NAND_ALE hold time	tALH	$DH \times T - 0.42$ [see note ²]		
NF8	Command/address NAND_DATAxx setup time	tCAS	$DS \times T - 0.26$ [see note ²]		
NF9	Command/address NAND_DATAxx hold time	tCAH	$DH \times T - 1.37$ [see note ²]		
NF18	NAND_CEx_B access time	tCE	$CE_DELAY \times T$ [see notes ^{3,2}]	—	ns
NF22	clock period	tCK	—	—	ns
NF23	preamble delay	tPRE	$PRE_DELAY \times T$ [see notes ^{4,2}]	—	ns

Table 51. Toggle mode timing parameters (continued)

ID	Parameter	Symbol	Timing T = GPMI Clock Cycle		Unit
			Min.	Max.	
NF24	postamble delay	tPOST	POST_DELAY × T + 0.43 [see note ²]	—	ns
NF28	Data write setup	tDS ⁵	0.25 × tCK - 0.32	—	ns
NF29	Data write hold	tDH ⁵	0.25 × tCK - 0.79	—	ns
NF30	NAND_DQS/NAND_DQ read setup skew	tDQSQ ⁶	—	3.18	ns
NF31	NAND_DQS/NAND_DQ read hold skew	tQHS ⁶	—	3.27	ns

¹ AS minimum value can be 0, while DS/DH minimum value is 1.

² T = tCK (GPMI clock period) - 0.075 ns (half of maximum p-p jitter).

³ CE_DELAY represents HW_GPMI_TIMING2[CE_DELAY]. NF18 is guaranteed by the design. Read/Write operation is started with enough time of ALE/CLE assertion to low level.

⁴ PRE_DELAY + 1 ≥ (AS + DS)

⁵ Shown in Figure 32.

⁶ Shown in Figure 33.

For DDR Toggle mode, Figure 31 shows the timing diagram of NAND_DQS/NAND_DATAxx read valid window. The typical value of tDQSQ is 1.4 ns (max) and 1.4 ns (max) for tQHS at 133 MB/s. GPMI samples NAND_DATA[7:0] at both the rising and falling edges of a delayed NAND_DQS signal, which is provided by an internal DPLL. The delay value of this register can be controlled by the GPMI register GPMI_READ_DDR_DLL_CTRL.SLV_DLY_TARGET (see the GPMI chapter of the *i.MX 8M Nano Applications Processor Reference Manual* [IMX8MNRM]). Generally, the typical delay value is equal to 0x7, which means a 1/4 clock cycle delay is expected. But if the board delay is big enough and cannot be ignored, the delay value should be made larger to compensate the board delay.

3.9.5 I²C bus characteristics

The Inter-Integrated Circuit (I2C) provides functionality of a standard I2C master and slave. The I2C is designed to be compatible with the I2C Bus Specification, version 2.1, by Philips Semiconductor (now NXP Semiconductors).

3.9.6 MIPI D-PHY timing parameters

MIPI D-PHY electrical specifications are compliance.

Table 52. MIPI PHY worst power dissipation¹

MODE		Power consume on VDD_MIPI_0P8 (mW)	Power consume on VDD_MIPI_1P2 (mW)	Power consume on VDD_MIPI_1P8 (mW)	Total power consume (mW)
2.1 Gbps	M4 on S4 on	226.1	4.1	35.6	265.8
	M4 on S4 off	164.7	4.03	28.6	197.33
	M4 off S4 on	63.02	0	15.8	78.82
ULPS		4.26	0.0367	0.0584	4.36

¹ M4 indicates MIPI DSI have 4 data lane enable (at least 1 clock lane enable). S4 indicates MIPI CSI have 4 data lane enable (at least 1 clock lane enable).

3.9.7 PDM timing parameters

Figure 34 illustrates the input timing of the PDM.

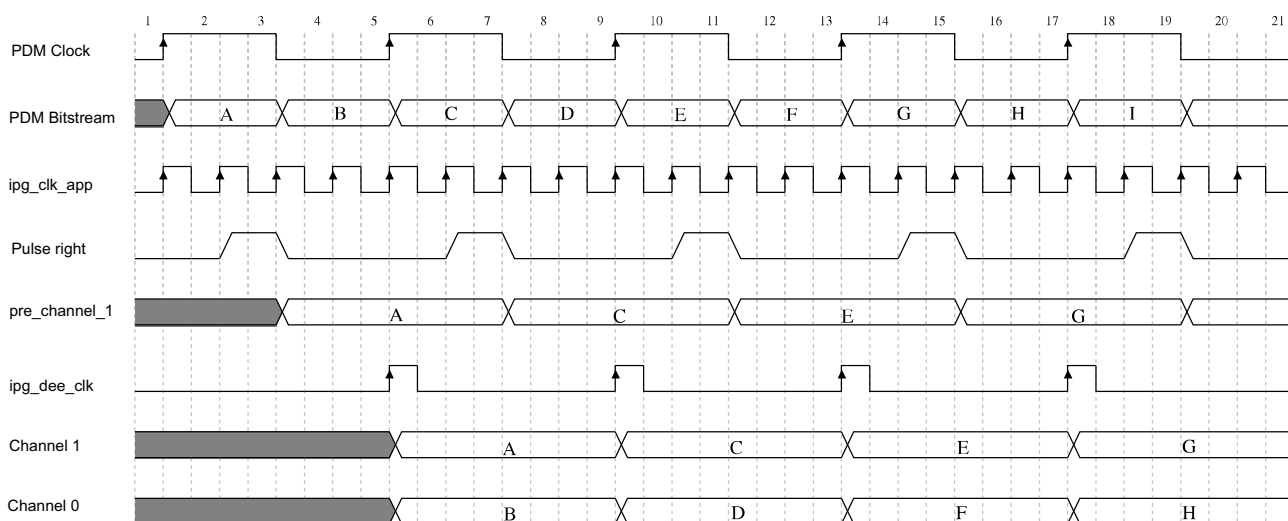

Figure 34. PDM input timing

PDM clock operative range is from 500 kHz to 6 MHz. Within range, only need to configure ipg_clk_app rate and CLKDIV without I/O timing concerns.

3.9.8 Pulse width modulator (PWM) timing parameters

This section describes the electrical information of the PWM. The PWM can be programmed to select one of three clock signals as its source frequency. The selected clock signal is passed through a prescaler before

Electrical characteristics

being input to the counter. The output is available at the pulse-width modulator output (PWMO) external pin.

Figure 35 depicts the timing of the PWM, and Table 53 lists the PWM timing parameters.

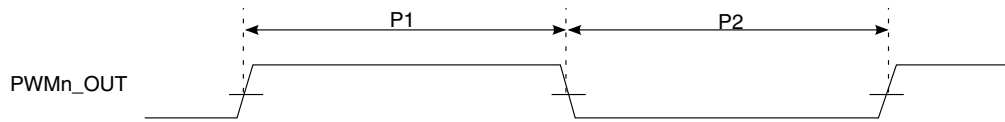

Figure 35. PWM timing

Table 53. PWM output timing parameters

ID	Parameter	Min	Max	Unit
	PWM Module Clock Frequency	0	66 (ipg_clk)	MHz
P1	PWM output pulse width high	12	—	ns
P2	PWM output pulse width low	12	—	ns

3.9.9 FlexSPI timing parameters

Measurements are with a load of 15 pF and an input slew rate of 1 V/ns.

3.9.9.1 FlexSPI input/read timing

There are three sources for the internal sample clock for FlexSPI read data:

- Dummy read strobe generated by FlexSPI controller and looped back internally (FlexSPI_n_MCR0[RXCLKSRC] = 0x0)
- Dummy read strobe generated by FlexSPI controller and looped back through the DQS pad (FlexSPI_n_MCR0[RXCLKSRC] = 0x1)
- Read strobe provided by memory device and input from DQS pad (FlexSPI_n_MCR0[RXCLKSRC] = 0x3)

The following sections describe input signal timing for each of these four internal sample clock sources.

3.9.9.1.1 SDR mode with FlexSPI_n_MCR0[RXCLKSRC] = 0x0, 0x1, 0x2

Table 54. FlexSPI input timing in SDR mode where FlexSPI_n_MCR0[RXCLKSRC] = 0x0

Symbol	Parameter	Min.	Max.	Unit	Notes
—	[D:] Frequency of operation	—	66	MHz	—
F1	[D:] Setup time for incoming data	8.67	—	ns	1
F2	[D:] Hold time for incoming data	0	—	ns	—

¹ The setup specification here assumes the data learning feature is not used. If data learning is enabled, then TIS can be decreased by up to 2ns.

Table 55. FlexSPI input timing in SDR mode where FlexSPI_n_MCR0[RXCLKSRC] = 0x1, 0x2

Symbol	Parameter	Min.	Max.	Unit	Notes
—	[D:] Frequency of operation	—	133	MHz	—
F1	[D:] Setup time for incoming data	1.5	—	ns	1
F2	[D:] Hold time for incoming data	1	—	ns	—

¹ The setup specification here assumes the data learning feature is not used. If data learning is enabled, then TIS can be decreased by up to 2ns.

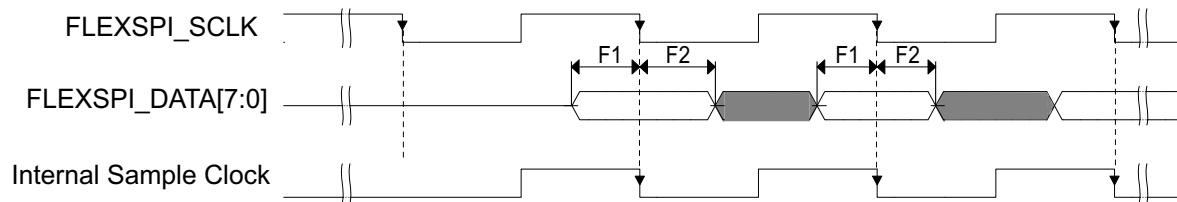
**Figure 36. FlexSPI input timing in SDR mode where FlexSPI_n_MCR0[RXCLKSRC] = 0x0, 0x1, 0x2****NOTE**

Timing shown is based on the memory generating read data on the SCK falling edge, and FlexSPI controller sampling read data on the falling edge.

3.9.9.1.2 SDR mode with FlexSPI_n_MCR0[RXCLKSRC] = 0x3

There are two cases when the memory provides both read data and the read strobe in SDR mode:

- A1—Memory generates both read data and read strobe on SCK rising edge (or falling edge)
- A2—Memory generates read data on SCK falling edge and generates read strobe on SCK rising edge

Table 56. FlexSPI input timing in SDR mode where FlexSPI_n_MCR0[RXCLKSRC] = 0x3 (Case A1)

Symbol	Parameter	Min.	Max.	Unit
—	[D:] Frequency of operation	—	166	MHz
F3	[D:] Time from SCK to data valid	—	—	ns
F4	[D:] Time from SCK to DQS	—	—	ns
—	[D:] Time delta between TSCKD and TSCKDQS	-2	2	ns

Electrical characteristics

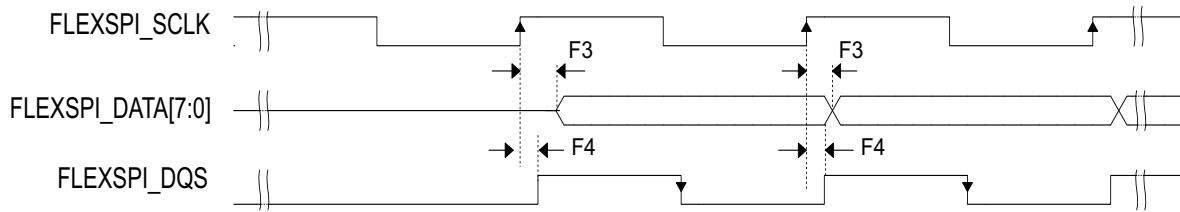

Figure 37. FlexSPI input timing in SDR mode where FlexSPI_n_MCR0[RXCLKSRC] = 0x3 (Case A1)

NOTE

Timing shown is based on the memory generating read data and read strobe on the SCK rising edge. The FlexSPI controller samples read data on the DQS falling edge.

Table 57. FlexSPI input timing in SDR mode where FlexSPI_n_MCR0[RXCLKSRC] = 0x3 (Case A2)

Symbol	Parameter	Min.	Max.	Unit
—	[D:] Frequency of operation	—	166	MHz
F5	[D:] Time from SCK to data valid	—	—	ns
F6	[D:] Time from SCK to DQS	—	—	ns
—	[D:] Time delta between TSCKD and TSCKDQDS	-2	2	ns

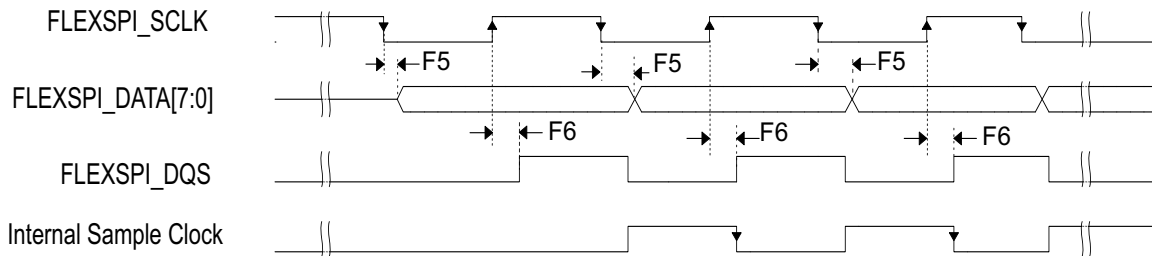

Figure 38. FlexSPI input timing in SDR mode where FlexSPI_n_MCR0[RXCLKSRC] = 0x3 (Case A2)

NOTE

Timing shown is based on the memory generating read data on the SCK falling edge and read strobe on the SCK rising edge. The FlexSPI controller samples read data on a half-cycle delayed DQS falling edge.

3.9.9.1.3 DDR mode with FlexSPIn_MCR0[RXCLKSRC] = 0x0, 0x1, 0x2

Table 58. FlexSPI input timing in DDR mode where FlexSPIn_MCR0[RXCLKSRC] = 0x0

Symbol	Parameter	Min.	Max.	Unit	Notes
—	[D:] Frequency of operation	—	33	MHz	—
F1	[D:] Setup time for incoming data	8.67	—	ns	1
F2	[D:] Hold time for incoming data	0	—	ns	—

¹ The setup specification here assumes the data learning feature is not used. If data learning is enabled, then TIS can be decreased by up to 2ns.

Table 59. FlexSPI input timing in DDR mode where FlexSPIn_MCR0[RXCLKSRC] = 0x1, 0x2

Symbol	Parameter	Min.	Max.	Unit	Notes
—	[D:] Frequency of operation	—	66	MHz	—
F1	[D:] Setup time for incoming data	1.5	—	ns	1
F2	[D:] Hold time for incoming data	1	—	ns	—

¹ The setup specification here assumes the data learning feature is not used. If data learning is enabled, then TIS can be decreased by up to 2ns.

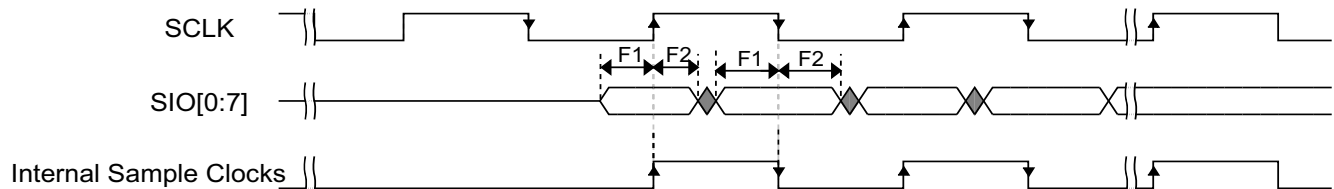

Figure 39. FlexSPI input timing in DDR mode where FlexSPIn_MCR0[RXCLKSRC] = 0x0, 0x1, 0x2

3.9.9.1.4 DDR mode with FlexSPIn_MCR0[RXCLKSRC] = 0x3

Table 60. FlexSPI input timing in DDR mode where FlexSPIn_MCR0[RXCLKSRC] = 0x3 (Case 1)

Symbol	Parameter	Min.	Max.	Unit
—	[D:] Frequency of operation	—	166	MHz
T_{SCKD}	[D:] Time from SCK to data valid	—	—	ns
T_{SCKDQS}	[D:] Time from SCK to DQS	—	—	ns
$T_{SCKD} - T_{SCKDQS}$	[D:] Time delta between T_{SCKD} and T_{SCKDQS}	-0.6	0.6	ns

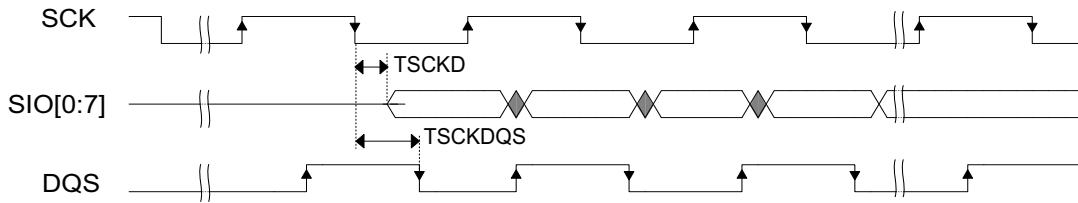

Figure 40. FlexSPI input timing in DDR mode where FlexSPI_n_MCR0[RXCLKSRC] = 0x3

3.9.9.2 FlexSPI output/write timing

The following sections describe output signal timing for the FlexSPI controller including control signals and data outputs.

3.9.9.2.1 SDR mode

Table 61. FlexSPI output timing in SDR mode

Symbol	Parameter	Min.	Max.	Unit
—	[D:] Frequency of operation ¹	—	166	MHz
T _{CK}	[D:] SCK clock period	6.02	—	ns
T _{D_{SO}}	[D:] Output data setup time	2	—	ns
T _{D_{HO}}	[D:] Output data hold time	2	—	ns
T _{C_{SS}}	[D:] Chip select output setup time	3 x T _{CK} - 1	—	ns
T _{C_{SH}}	[D:] Chip select output hold time	3 x T _{CK} - 1	—	ns

¹ The actual maximum frequency supported is limited by the FlexSPI_n_MCR0[RXCLKSRC] configuration used. See the FlexSPI SDR input timing specifications.

T_{C_{SS}} and T_{C_{SH}} are configured by the FlexSPI_n_FLSHAxCR1 register, the default values are shown above. See the *i.MX 8M Nano Applications Processor Reference Manual (IMX8MNRM)* for more details.

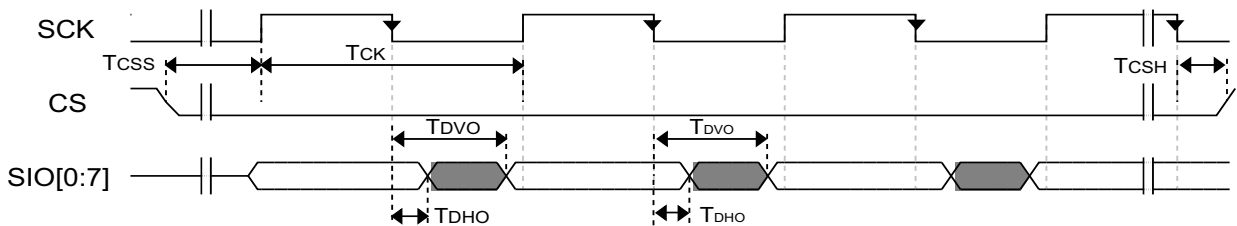

Figure 41. FlexSPI output timing in SDR mode

3.9.9.2.2 DDR mode

Table 62. FlexSPI output timing in DDR mode

Symbol	Parameter	Min.	Max.	Unit
—	[D:] Frequency of operation ¹	—	166	MHz
T_{CK}	[D:] SCK clock period	6.02	—	ns
T_{DSO}	[D:] Output data setup time	—	0.6	ns
T_{DHO}	[D:] Output data hold time	0.6	—	ns
T_{CSS}	[D:] Chip select output setup time	$3 \times T_{CK} - 1.075$	—	ns
T_{CSH}	[D:] Chip select output hold time	$3 \times T_{CK} - 1.075$	—	ns

¹ The actual maximum frequency supported is limited by the FlexSPI_n_MCR0[RXCLKSRC] configuration used. See the FlexSPI SDR input timing specifications.

NOTE

T_{CSS} and T_{CSH} are configured by the FlexSPI_n_FLSHAxCR1 register, the default values are shown above. See the *i.MX 8M Nano Applications Processor Reference Manual (IMX8MNRM)* for more details.

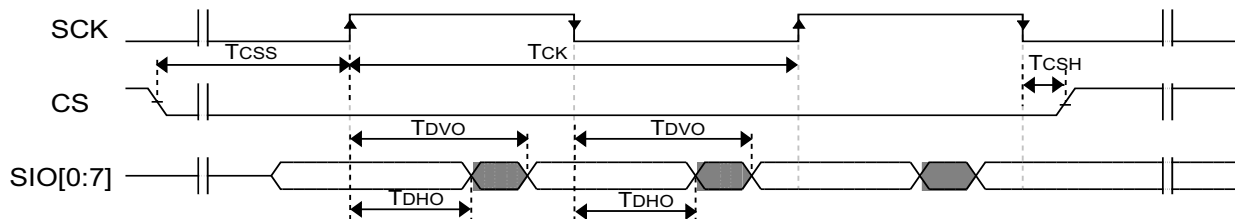

Figure 42. FlexSPI output timing in DDR mode

3.9.10 SAI/I2S switching specifications

This section provides the AC timings for the SAI in Master (clocks driven) and Slave (clocks input) modes. All timings are given for non inverted serial clock polarity (SAI_TCR[TSCKP] = 0, SAI_RCR[RSCKP] = 0) and non inverted frame sync (SAI_TCR[TFSI] = 0, SAI_RCR[RFSI] = 0). If the polarity of the clock and/or the frame sync have been inverted, all the timings remain valid by inverting the clock signal (SAI_BCLK) and/or the frame sync (SAI_FS) shown in the figures below.

Table 63. Master mode SAI timing (50 MHz)¹

Num	Characteristic	Min	Max	Unit
S1	SAI_MCLK cycle time	20	—	ns
S2	SAI_MCLK pulse width high/low	40%	60%	MCLK period
S3	SAI_BCLK cycle time	20	—	ns

Electrical characteristics

Table 63. Master mode SAI timing (50 MHz)¹ (continued)

Num	Characteristic	Min	Max	Unit
S4	SAI_BCLK pulse width high/low	40%	60%	BCLK period
S5	SAI_BCLK to SAI_FS output valid	—	2	ns
S6	SAI_BCLK to SAI_FS output invalid	0	—	ns
S7	SAI_BCLK to SAI_TXD valid	—	2	ns
S8	SAI_BCLK to SAI_TXD invalid	0	—	ns
S9	SAI_RXD/SAI_FS input setup before SAI_BCLK	2	—	ns
S10	SAI_RXD/SAI_FS input hold after SAI_BCLK	0	—	ns

¹ To achieve 50 MHz for BCLK operation, clock must be set in feedback mode.

Table 64. Master mode SAI timing (25 MHz)

Num	Characteristic	Min	Max	Unit
S1	SAI_MCLK cycle time	40	—	ns
S2	SAI_MCLK pulse width high/low	40%	60%	MCLK period
S3	SAI_BCLK cycle time	40	—	ns
S4	SAI_BCLK pulse width high/low	40%	60%	BCLK period
S5	SAI_BCLK to SAI_FS output valid	—	2	ns
S6	SAI_BCLK to SAI_FS output invalid	0	—	ns
S7	SAI_BCLK to SAI_TXD valid	—	2	ns
S8	SAI_BCLK to SAI_TXD invalid	0	—	ns
S9	SAI_RXD/SAI_FS input setup before SAI_BCLK	12	—	ns
S10	SAI_RXD/SAI_FS input hold after SAI_BCLK	0	—	ns

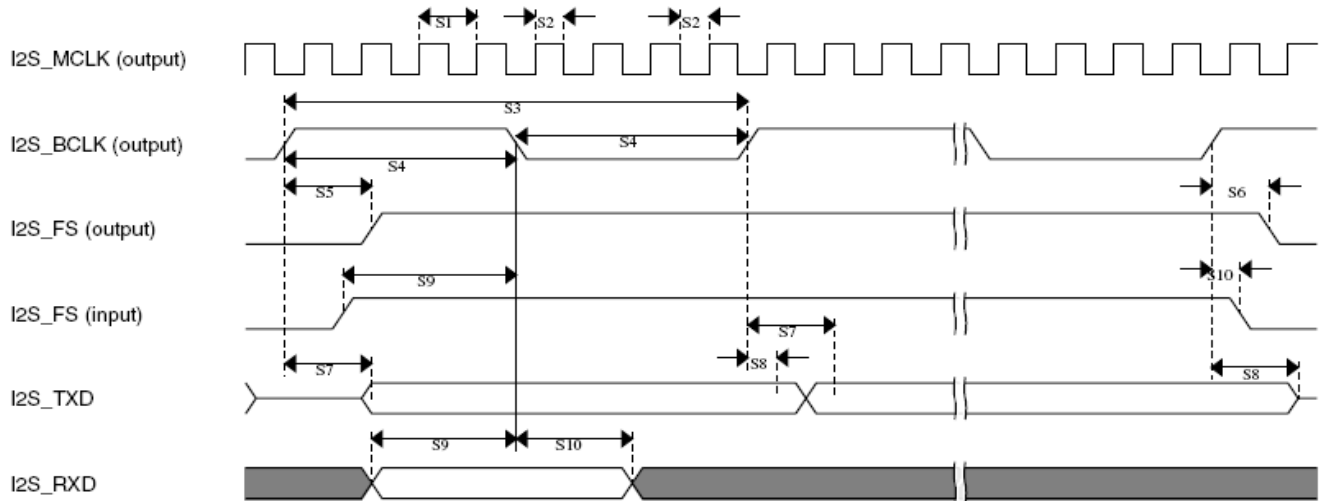

Figure 43. SAI timing—Master modes

Table 65. Slave mode SAI timing (50 MHz)¹

Num	Characteristic	Min	Max	Unit
S11	SAI_BCLK cycle time (input)	20	—	ns
S12	SAI_BCLK pulse width high/low (input)	40%	60%	BCLK period
S13	SAI_FS input setup before SAI_BCLK	2	—	ns
S14	SAI_FA input hold after SAI_BCLK	2	—	ns
S17	SAI_RXD setup before SAI_BCLK	2	—	ns
S18	SAI_RXD hold after SAI_BCLK	2	—	ns

¹ TX does not support 50 MHz operation in Slave mode.

Table 66. Slave mode SAI timing (25 MHz)

Num	Characteristic	Min	Max	Unit
S11	SAI_BCLK cycle time (input)	40	—	ns
S12	SAI_BCLK pulse width high/low (input)	40%	60%	BCLK period
S13	SAI_FS input setup before SAI_BCLK	12	—	ns
S14	SAI_FA input hold after SAI_BCLK	2	—	ns
S15	SAI_BCLK to SAI_TXD/SAI_FS output valid	—	7	ns
S16	SAI_BCLK to SAI_TXD/SAI_FS output invalid	0	—	ns
S17	SAI_RXD setup before SAI_BCLK	12	—	ns
S18	SAI_RXD hold after SAI_BCLK	2	—	ns

Electrical characteristics

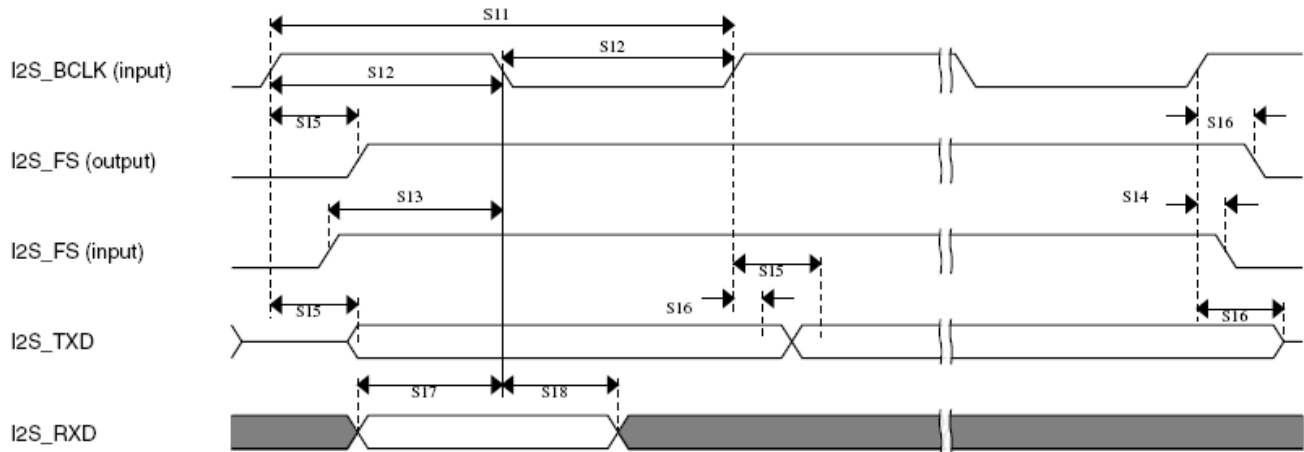

Figure 44. SAI Timing — Slave Modes

3.9.11 SPDIF timing parameters

The Sony/Philips Digital Interconnect Format (SPDIF) data is sent using the bi-phase marking code. When encoding, the SPDIF data signal is modulated by a clock that is twice the bit rate of the data signal.

Table 67 and Figure 45 and Figure 46 show SPDIF timing parameters for the Sony/Philips Digital Interconnect Format (SPDIF), including the timing of the modulating Rx clock (SPDIF_SR_CLK) for SPDIF in Rx mode and the timing of the modulating Tx clock (SPDIF_ST_CLK) for SPDIF in Tx mode.

Table 67. SPDIF timing parameters

Parameter	Symbol	Timing Parameter Range		Unit
		Min	Max	
SPDIF_IN Skew: asynchronous inputs, no specs apply	—	—	0.7	ns
SPDIF_OUT output (Load = 50 pf)				
• Skew	—	—	1.5	ns
• Transition rising	—	—	24.2	
• Transition falling	—	—	31.3	
SPDIF_OUT output (Load = 30 pf)				
• Skew	—	—	13.6	ns
• Transition rising	—	—	18.0	
• Transition falling	—	—	—	
Modulating Rx clock (SPDIF_SR_CLK) period	srckp	40.0	—	ns
SPDIF_SR_CLK high period	srckph	16.0	—	ns
SPDIF_SR_CLK low period	srckpl	16.0	—	ns
Modulating Tx clock (SPDIF_ST_CLK) period	stckp	40.0	—	ns
SPDIF_ST_CLK high period	stckph	16.0	—	ns
SPDIF_ST_CLK low period	stckpl	16.0	—	ns

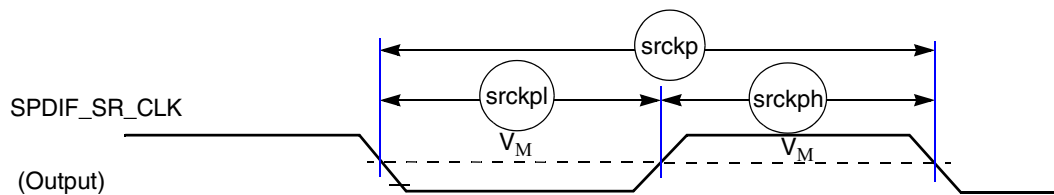

Figure 45. SPDIF_SR_CLK timing diagram

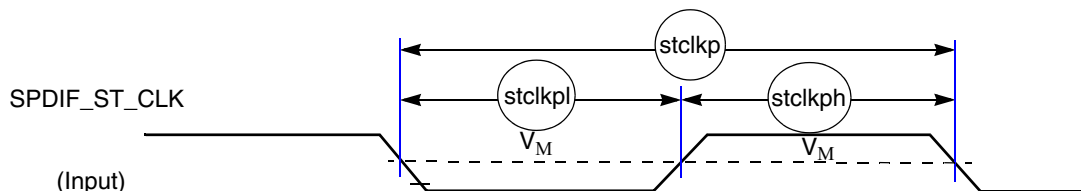

Figure 46. SPDIF_ST_CLK timing diagram

3.9.12 UART I/O configuration and timing parameters

3.9.12.1 UART RS-232 I/O configuration in different modes

The i.MX 8M Nano UART interfaces can serve both as DTE or DCE device. This can be configured by the DCEDTE control bit (default 0—DCE mode). Table 68 shows the UART I/O configuration based on the enabled mode.

Table 68. UART I/O configuration vs. mode

Port	DTE Mode		DCE Mode	
	Direction	Description	Direction	Description
UARTx_RTS_B	Output	UARTx_RTS_B from DTE to DCE	Input	UARTx_RTS_B from DTE to DCE
UARTx_CTS_B	Input	UARTx_CTS_B from DCE to DTE	Output	UARTx_CTS_B from DCE to DTE
UARTx_TX_DATA	Input	Serial data from DCE to DTE	Output	Serial data from DCE to DTE
UARTx_RX_DATA	Output	Serial data from DTE to DCE	Input	Serial data from DTE to DCE

3.9.12.2 UART RS-232 Serial mode timing

This section describes the electrical information of the UART module in the RS-232 mode.

3.9.12.2.1 UART transmitter

Figure 47 depicts the transmit timing of UART in the RS-232 Serial mode, with 8 data bit/1 stop bit format. Table 69 lists the UART RS-232 Serial mode transmit timing characteristics.

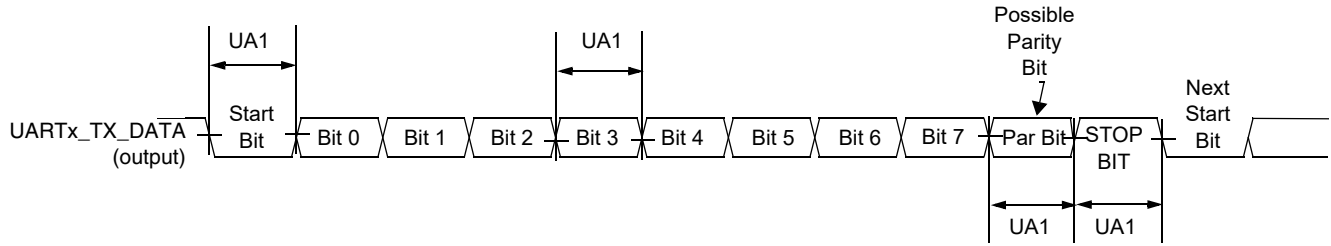

Figure 47. UART RS-232 Serial mode transmit timing diagram

Table 69. RS-232 Serial mode transmit timing parameters

ID	Parameter	Symbol	Min	Max	Unit
UA1	Transmit Bit Time	t_{Tbit}	$1/F_{baud_rate}^1 - T_{ref_clk}^2$	$1/F_{baud_rate} + T_{ref_clk}$	—

¹ F_{baud_rate} : Baud rate frequency. The maximum baud rate the UART can support is $(ipg_perclk \text{ frequency})/16$.

² T_{ref_clk} : The period of UART reference clock ref_clk (ipg_perclk after RFDIV divider).

3.9.12.2.2 UART receiver

Figure 48 depicts the RS-232 Serial mode receive timing with 8 data bit/1 stop bit format. Table 70 lists Serial mode receive timing characteristics.

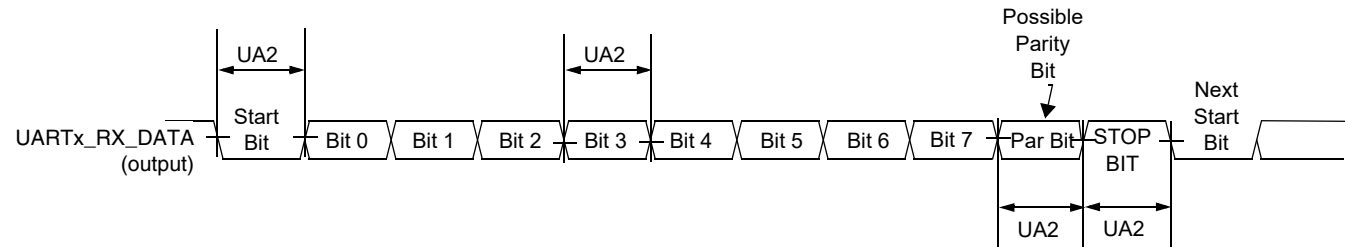

Figure 48. UART RS-232 Serial mode receive timing diagram

Table 70. RS-232 Serial mode receive timing parameters

ID	Parameter	Symbol	Min	Max	Unit
UA2	Receive Bit Time ¹	t_{Rbit}	$1/F_{baud_rate}^2 - 1/(16 \times F_{baud_rate})$	$1/F_{baud_rate} + 1/(16 \times F_{baud_rate})$	—

¹ The UART receiver can tolerate $1/(16 \times F_{baud_rate})$ tolerance in each bit. But accumulation tolerance in one frame must not exceed $3/(16 \times F_{baud_rate})$.

² F_{baud_rate} : Baud rate frequency. The maximum baud rate the UART can support is $(ipg_perclk \text{ frequency})/16$.

3.9.13 USB PHY parameters

This section describes the USB-OTG PHY parameters.

3.9.13.1 Pad/Package/Board connections

The USB1_VBUS pin cannot directly connect to the 5 V VBUS voltage on the USB2.0 link.

Each USB1_VBUS pin must be isolated by an external 30 K Ω 1% precision resistor.

The USB 2.0 PHY uses USB1_TXRTUNE and an external resistor to calibrate the USB1_DP/DN 45 Ω source impedance. The external resistor value is 200 Ω 1% precision on USB1_TXRTUNE pad to ground.

3.9.13.2 USB PHY worst power consumption

Table 71 shows the USB 2.0 PHY worst power dissipation.

Table 71. USB 2.0 PHY worst power dissipation

Mode	VDD_USB_0P8		VDD_USB_3P3		VDD_USB_1P8		Total Power	
HS TX	8.286	mA	4.63	mA	23.409	mA	70.448	mW
FS TX	6.767		12.52		5.968		63.22	
LS TX	7.001		13.58		6.224		67.779	
Suspend	0.752		0.164		0.106		1.465	
Sleep	0.761		0.163		0.106		1.472	

4 Boot mode configuration

This section provides information on Boot mode configuration pins allocation and boot devices interfaces allocation.

4.1 Boot mode configuration pins

Table 72 provides boot options, functionality, fuse values, and associated pins. Several input pins are also sampled at reset and can be used to override fuse values, depending on the value of BT_FUSE_SEL fuse. The boot option pins are in effect when BT_FUSE_SEL fuse is '0' (cleared, which is the case for an unblown fuse). For detailed Boot mode options configured by the Boot mode pins, see the “System Boot, Fusemap, and eFuse” chapter in the *i.MX 8M Nano Applications Processor Reference Manual* (IMX8MNRM).

Table 72. Fuses and associated pins used for boot

Interface	IP instance	Allocated pads during boot	Comment
BOOT_MODE0	Input	ccmsrcgpcmix.BOOT_MODE[0]	Boot mode selection
BOOT_MODE1	Input	ccmsrcgpcmix.BOOT_MODE[1]	
BOOT_MODE2	Input	ccmsrcgpcmix.BOOT_MODE[2]	
BOOT_MODE3	Input	ccmsrcgpcmix.BOOT_MODE[3]	

4.2 Boot device interface allocation

Table 73 lists the interfaces that can be used by the boot process in accordance with the specific Boot mode configuration. The table also describes the interface’s specific modes and IOMUXC allocation, which are configured during boot when appropriate.

Table 73. Interface allocation during boot

Interface	IP Instance	Allocated Pads During Boot	Comment
SPI	ECSPI-1	ECSPI1_SCLK, ECSPI1_MOSI, ECSPI1_MISO, ECSPI1_SS0	The chip-select pin used depends on the fuse “CS select (SPI only)”.
SPI	ECSPI-2	ECSPI2_SCLK, ECSPI2_MOSI, ECSPI2_MISO, ECSPI2_SS0	The chip-select pin used depends on the fuse “CS select (SPI only)”.
SPI	ECSPI-3	UART1_RXD, UART1_TXD, UART2_RXD, UART2_TXD	The chip-select pin used depends on the fuse “CS select (SPI only)”.
NAND Flash	GPMI	NAND_ALE, NAND_CE0_B, NAND_CLE, NAND_DATA00, NAND_DATA01, NAND_DATA02, NAND_DATA03, NAND_DATA04, NAND_DATA05, NAND_DATA06, NAND_DATA07, NAND_DQS, NAND_RE_B, NAND_READY_B, NAND_WE_B, NAND_WP_B	8-bit, only CS0 is supported.

Table 73. Interface allocation during boot (continued)

Interface	IP Instance	Allocated Pads During Boot	Comment
SD/MMC	USDHC-1	GPIO1_IO03, GPIO1_IO06, GPIO1_IO07, SD1_RESET_B, SD1_CLK, SD1_CMD, SD1_STROBE, SD1_DATA0, SD1_DATA1, SD1_DATA2, SD1_DATA3, SD1_DATA4, SD1_DATA5, SD1_DATA6, SD1_DATA7	1, 4, or 8-bit
SD/MMC	USDHC-2	GPIO1_IO04, GPIO1_IO08, GPIO1_IO07, SD2_RESET_B, SD2_WP, SD2_CLK, SD2_CMD, SD2_DATA0, SD2_DATA1, SD2_DATA2, SD2_DATA3	1 or 4-bit
SD/MMC	USDHC-3	NAND_CE1_B, NAND_CE2_B, NAND_CE3_B, NAND_CLE, NAND_DATA02, NAND_DATA03, NAND_DATA04, NAND_DATA05, NAND_DATA06, NAND_DATA07, NAND_RE_B, NAND_READY_B, NAND_WE_B, NAND_WP_B	1, 4, or 8-bit
FlexSPI	FlexSPI	NAND_ALE, NAND_CE0_B, NAND_CE1_B, NAND_CE2_B, NAND_CE3_B, NAND_CLE, NAND_DATA00, NAND_DATA01, NAND_DATA02, NAND_DATA03, NAND_DATA04, NAND_DATA05, NAND_DATA06, NAND_DATA07, NAND_DQS, NAND_RE_B	For FlexSPI flash
USB	USB_OTG PHY	Dedicated USB pins	—

5 Package information and contact assignments

This section includes the contact assignment information and mechanical package drawing.

5.1 14 x 14 mm package information

5.1.1 14 x 14 mm, 0.5 mm pitch, ball matrix

[Figure 49](#) shows the top, bottom, and side views of the 14 × 14 mm FCBGA package.

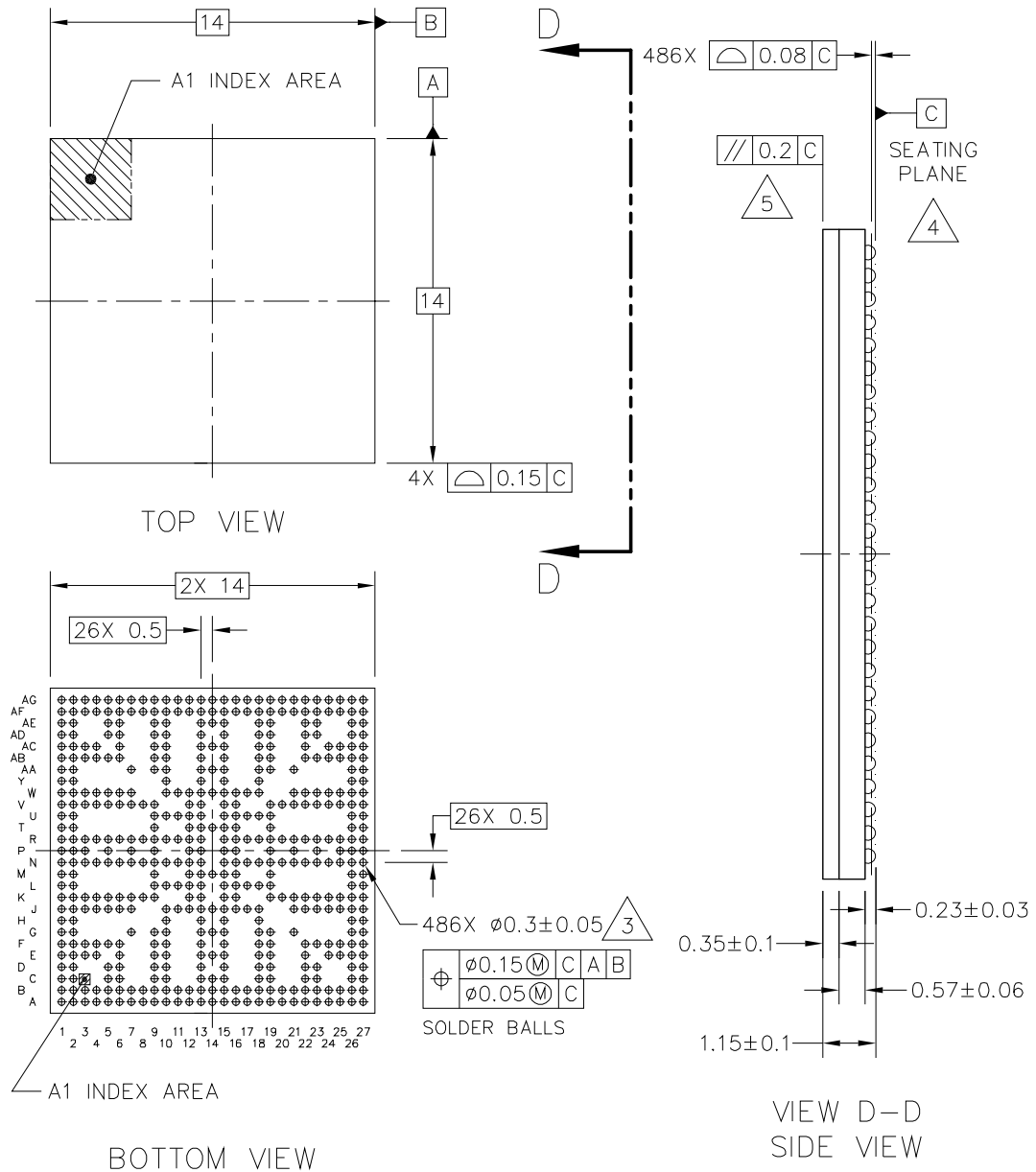

© NXP SEMICONDUCTORS N.V. ALL RIGHTS RESERVED	MECHANICAL OUTLINE	PRINT VERSION NOT TO SCALE
TITLE: FCPBGA, MOLDED ARRAY, 14 X 14 X 1.15 PKG, 0.5 MM PITCH, 486 I/O	DOCUMENT NO: 98ASA01200D	REV: B
	STANDARD: NON-JEDEC	
	SOT1967-1	02 AUG 2018

Figure 49. 14 X 14 MM BGA, case x package top, bottom, and side views

5.1.2 14 x 14 mm supplies contact assignments and functional contact assignments

Table 74 shows supplies contact assignments for the 14 x 14 mm package.

Table 74. i.MX 8M Nano 14 x 14 mm supplies contact assignments

Supply Rail Name	Ball(s) Position(s)	Remark
NVCC_CLK	M19	Supply for CLK interface
NVCC_DRAM	P7, K8, N8, R8, V8, K9, L9, M9, N9, R9, T9, U9, V9	Supply for DRAM interface
NVCC_ECSPi	H10	Supply for ECSPi interface
NVCC_ENET	W22	Supply for ENET interface
NVCC_GPIO1	W12	Supply for GPIO1 interface
NVCC_I2C	J11	Supply for I2C interface
NVCC_JTAG	L19	Supply for JTAG interface
NVCC_NAND	U19	Supply for NAND interface
NVCC_SAI2	V19	Supply for SAI interface
NVCC_SAI3	Y10	Supply for SAI interface
NVCC_SAI5	W17	Supply for SAI interface
NVCC_SD1	V20	Supply for SD interface
NVCC_SD2	V22	Supply for SD interface
NVCC_SNVS_1P8	J22	Supply for SNVS interface
NVCC_UART	J12	Supply for UART interface
PVCC0_1P8	AB13	Digital IO pre-drive
PVCC1_1P8	T19	Digital IO pre-drive
PVCC2_1P8	J13	Digital IO pre-drive
VDD_24M_XTAL_1P8	N19	Supply for XTAL
VDD_ANA_0P8	L17, N17	Supply for Analog logic
VDD_ANA0_1P8	AA14, Y15	Supply for Analog logic
VDD_ANA1_1P8	P19, N20	Supply for Analog logic
VDD_ARM	R13, T13, U13, V13, W13, T14, W14, R15, T15, U15, V15, W15, V16, W16	Supply for ARM
VDD_ARM_PLL_0P8	P16	Supply for ARM PLL
VDD_ARM_PLL_1P8	R19	Supply for ARM PLL
VDD_DRAM	J10, L10, N10, R10, U10, W10	Supply for DRAM module
VDD_DRAM_PLL_0P8	P9	Supply for DRAM PLL
VDD_DRAM_PLL_1P8	P5	Supply for DRAM PLL

Table 74. i.MX 8M Nano 14 x 14 mm supplies contact assignments (continued)

VDD_GPU	R11, U11, W11, P12, V12	Supply for GPU
VDD_MIPI_0P8	J14	Supply for MIPI PHY
VDD_MIPI_1P2	J15	Supply for MIPI PHY
VDD_MIPI_1P8	H13	Supply for MIPI PHY
VDD_SNVS_0P8	K22	Supply for SNVS logic
VDD_SOC	N13, K15, L15, M15, N15, K16, R17, U17, L18, N18, R18, U18	Supply for SOC logic
VDD_USB_0P8	J17	Supply for USB PHY
VDD_USB_1P8	H15	Supply for USB PHY
VDD_USB_3P3	K19	Supply for USB PHY
VSS	A1, AG1, C2, H2, Y2, AE2, B3, E3, F3, J3, K3, N3, P3, R3, V3, W3, AB3, AC3, AF3, C5, AE5, C6, AE6, G7, J7, K7, N7, R7, V7, W7, AA7, C9, G9, AA9, AE9, C10, G10, AA10, AE10, L12, M12, N12, R12, T12, U12, C13, G13, P13, Y13, AA13, AE13, C14, AE14, C15, G15, P15, AA15, AE15, L16, M16, N16, R16, T16, U16, C18, G18, H18, Y18, AA18, AE18, C19, G19, AA19, AE19, K20, R20, G21, J21, K21, N21, P21, R21, V21, W21, AA21, C22, AE22, C23, AE23, E25, F25, J25, K25, N25, P25, R25, V25, W25, AB25, AC25, B26, A27, AG27	—

Table 75 shows an alpha-sorted list of functional contact assignments for the 14 x 14 mm package.

Table 75. i.MX 8M Nano 14 x 14 mm functional contact assignments

Ball name	Ball	Power group	Ball type	Reset condition		
				Default mode	Default function	Input/Output status
24M_XTALI	B27	NVCC_CLK	ANALOG	—	—	Input
24M_XTALO	C26	NVCC_CLK	ANALOG	—	—	Output
BOOT_MODE0	G26	NVCC_JTAG	GPIO	ALT0	ccmsrcgpcmix.BOOT_MODE[0]	Input with PD
BOOT_MODE1	G27	NVCC_JTAG	GPIO	ALT0	ccmsrcgpcmix.BOOT_MODE[1]	Input with PD
BOOT_MODE2	C27	NVCC_JTAG	GPIO	ALT0	ccmsrcgpcmix.BOOT_MODE[2]	Input with PD
BOOT_MODE3	D26	NVCC_JTAG	GPIO	ALT0	ccmsrcgpcmix.BOOT_MODE[3]	Input with PD
CLKIN1	H27	NVCC_CLK	GPIO	—	—	Input without PU/PD
CLKIN2	J27	NVCC_CLK	GPIO	—	—	Input without PU/PD
CLKOUT1	H26	NVCC_CLK	GPIO	—	—	Output low without PU/PD

Table 75. i.MX 8M Nano 14 x 14 mm functional contact assignments (continued)

Ball name	Ball	Power group	Ball type	Reset condition		
				Default mode	Default function	Input/Output status
CLKOUT2	J26	NVCC_CLK	GPIO	—	—	Output low without PU/PD
DRAM_AC00	F4	NVCC_DRAM	DDR	—	—	Output low
DRAM_AC01	F5	NVCC_DRAM	DDR	—	—	Output low
DRAM_AC02	K4	NVCC_DRAM	DDR	—	—	Input
DRAM_AC03	J4	NVCC_DRAM	DDR	—	—	Input
DRAM_AC04	L2	NVCC_DRAM	DDR	—	—	Input
DRAM_AC05	L1	NVCC_DRAM	DDR	—	—	Input
DRAM_AC06	F6	NVCC_DRAM	DDR	—	—	Input
DRAM_AC07	J5	NVCC_DRAM	DDR	—	—	Input
DRAM_AC08	J6	NVCC_DRAM	DDR	—	—	Input
DRAM_AC09	K6	NVCC_DRAM	DDR	—	—	Input
DRAM_AC10	E4	NVCC_DRAM	DDR	—	—	Input
DRAM_AC11	D5	NVCC_DRAM	DDR	—	—	Input
DRAM_AC12	N4	NVCC_DRAM	DDR	—	—	Input
DRAM_AC13	N5	NVCC_DRAM	DDR	—	—	Input
DRAM_AC14	K5	NVCC_DRAM	DDR	—	—	Input
DRAM_AC15	N6	NVCC_DRAM	DDR	—	—	Input
DRAM_AC16	M1	NVCC_DRAM	DDR	—	—	Input
DRAM_AC17	M2	NVCC_DRAM	DDR	—	—	Input
DRAM_AC19	N2	NVCC_DRAM	DDR	—	—	Input
DRAM_AC20	AB4	NVCC_DRAM	DDR	—	—	Output low
DRAM_AC21	AB5	NVCC_DRAM	DDR	—	—	Output low
DRAM_AC22	W4	NVCC_DRAM	DDR	—	—	Input
DRAM_AC23	V4	NVCC_DRAM	DDR	—	—	Input
DRAM_AC24	U2	NVCC_DRAM	DDR	—	—	Input
DRAM_AC25	U1	NVCC_DRAM	DDR	—	—	Input
DRAM_AC26	N1	NVCC_DRAM	DDR	—	—	Input
DRAM_AC27	R6	NVCC_DRAM	DDR	—	—	Input
DRAM_AC28	W6	NVCC_DRAM	DDR	—	—	Input

Table 75. i.MX 8M Nano 14 x 14 mm functional contact assignments (continued)

Ball name	Ball	Power group	Ball type	Reset condition		
				Default mode	Default function	Input/Output status
DRAM_AC29	V6	NVCC_DRAM	DDR	—	—	Input
DRAM_AC30	AC4	NVCC_DRAM	DDR	—	—	Input
DRAM_AC31	AD5	NVCC_DRAM	DDR	—	—	Input
DRAM_AC32	R4	NVCC_DRAM	DDR	—	—	Input
DRAM_AC33	R5	NVCC_DRAM	DDR	—	—	Input
DRAM_AC34	T1	NVCC_DRAM	DDR	—	—	Input
DRAM_AC35	T2	NVCC_DRAM	DDR	—	—	Input
DRAM_AC36	V5	NVCC_DRAM	DDR	—	—	Input
DRAM_AC37	W5	NVCC_DRAM	DDR	—	—	Input
DRAM_AC38	AB6	NVCC_DRAM	DDR	—	—	Input
DRAM_ALERT_N	R2	NVCC_DRAM	DDR	—	—	Input
DRAM_DM0	A4	NVCC_DRAM	DDR	—	—	Input
DRAM_DM1	F1	NVCC_DRAM	DDR	—	—	Input
DRAM_DQ00	A5	NVCC_DRAM	DDR	—	—	Input
DRAM_DQ01	B5	NVCC_DRAM	DDR	—	—	Input
DRAM_DQ02	D2	NVCC_DRAM	DDR	—	—	Input
DRAM_DQ03	D1	NVCC_DRAM	DDR	—	—	Input
DRAM_DQ04	C1	NVCC_DRAM	DDR	—	—	Input
DRAM_DQ05	B1	NVCC_DRAM	DDR	—	—	Input
DRAM_DQ06	A3	NVCC_DRAM	DDR	—	—	Input
DRAM_DQ07	B4	NVCC_DRAM	DDR	—	—	Input
DRAM_DQ08	F2	NVCC_DRAM	DDR	—	—	Input
DRAM_DQ09	G2	NVCC_DRAM	DDR	—	—	Input
DRAM_DQ10	J1	NVCC_DRAM	DDR	—	—	Input
DRAM_DQ11	J2	NVCC_DRAM	DDR	—	—	Input
DRAM_DQ12	K2	NVCC_DRAM	DDR	—	—	Input
DRAM_DQ13	K1	NVCC_DRAM	DDR	—	—	Input
DRAM_DQ14	E1	NVCC_DRAM	DDR	—	—	Input
DRAM_DQ15	E2	NVCC_DRAM	DDR	—	—	Input
DRAM_DQS0_N	B2	NVCC_DRAM	—	—	—	Input

Table 75. i.MX 8M Nano 14 x 14 mm functional contact assignments (continued)

Ball name	Ball	Power group	Ball type	Reset condition		
				Default mode	Default function	Input/Output status
DRAM_DQS0_P	A2	NVCC_DRAM	DDRCLK	—	—	Input
DRAM_DQS1_N	H1	NVCC_DRAM	—	—	—	Input
DRAM_DQS1_P	G1	NVCC_DRAM	DDRCLK	—	—	Input
DRAM_RESET_N	R1	NVCC_DRAM	DDR	—	—	Output low
DRAM_VREF	P1	NVCC_DRAM	DDR	—	—	—
DRAM_ZN	P2	NVCC_DRAM	DDR	—	—	—
ECSPI1_MISO	A7	NVCC_ECSPi	GPIO	ALT5	GPIO5.IO[8]	Input with PD
ECSPI1_MOSI	B7	NVCC_ECSPi	GPIO	ALT5	GPIO5.IO[7]	Input with PD
ECSPI1_SCLK	D6	NVCC_ECSPi	GPIO	ALT5	GPIO5.IO[6]	Input with PD
ECSPI1_SS0	B6	NVCC_ECSPi	GPIO	ALT5	GPIO5.IO[9]	Input with PD
ECSPI2_MISO	A8	NVCC_ECSPi	GPIO	ALT5	GPIO5.IO[12]	Input with PD
ECSPI2_MOSI	B8	NVCC_ECSPi	GPIO	ALT5	GPIO5.IO[11]	Input with PD
ECSPI2_SCLK	E6	NVCC_ECSPi	GPIO	ALT5	GPIO5.IO[10]	Input with PD
ECSPI2_SS0	A6	NVCC_ECSPi	GPIO	ALT5	GPIO5.IO[13]	Input with PD
ENET_MDC	AC27	NVCC_ENET	GPIO	ALT5	GPIO1.IO[16]	Input with PD
ENET_MDIO	AB27	NVCC_ENET	GPIO	ALT5	GPIO1.IO[17]	Input with PD
ENET_RD0	AE27	NVCC_ENET	GPIO	ALT5	GPIO1.IO[26]	Input with PD
ENET_RD1	AD27	NVCC_ENET	GPIO	ALT5	GPIO1.IO[27]	Input with PD
ENET_RD2	AD26	NVCC_ENET	GPIO	ALT5	GPIO1.IO[28]	Input with PD
ENET_RD3	AC26	NVCC_ENET	GPIO	ALT5	GPIO1.IO[29]	Input with PD
ENET_RXC	AE26	NVCC_ENET	GPIO	ALT5	GPIO1.IO[25]	Input with PD
ENET_RX_CTL	AF27	NVCC_ENET	GPIO	ALT5	GPIO1.IO[24]	Input with PD
ENET_TD0	AG26	NVCC_ENET	GPIO	ALT5	GPIO1.IO[21]	Input with PD
ENET_TD1	AF26	NVCC_ENET	GPIO	ALT5	GPIO1.IO[20]	Input with PD
ENET_TD2	AG25	NVCC_ENET	GPIO	ALT5	GPIO1.IO[19]	Input with PD
ENET_TD3	AF25	NVCC_ENET	GPIO	ALT5	GPIO1.IO[18]	Input with PD
ENET_TXC	AG24	NVCC_ENET	GPIO	ALT5	GPIO1.IO[23]	Input with PD
ENET_TX_CTL	AF24	NVCC_ENET	GPIO	ALT5	GPIO1.IO[22]	Input with PD
GPIO1_IO00	AG14	NVCC_GPIO1	GPIO	ALT6	GPIO1.IO[0]	Input with PD
GPIO1_IO01	AF14	NVCC_GPIO1	GPIO	ALT6	GPIO1.IO[1]	1

Table 75. i.MX 8M Nano 14 x 14 mm functional contact assignments (continued)

Ball name	Ball	Power group	Ball type	Reset condition		
				Default mode	Default function	Input/Output status
GPIO1_IO02	AG13	NVCC_GPIO1	GPIO	ALT0	GPIO1.IO[2]	Input with PU
GPIO1_IO03	AF13	NVCC_GPIO1	GPIO	ALT0	GPIO1.IO[3]	Input with PD
GPIO1_IO04	AG12	NVCC_GPIO1	GPIO	ALT0	GPIO1.IO[4]	Input with PD
GPIO1_IO05	AF12	NVCC_GPIO1	GPIO	ALT6	GPIO1.IO[5]	1
GPIO1_IO06	AG11	NVCC_GPIO1	GPIO	ALT0	GPIO1.IO[6]	Input with PD
GPIO1_IO07	AF11	NVCC_GPIO1	GPIO	ALT0	GPIO1.IO[7]	Input with PD
GPIO1_IO08	AG10	NVCC_GPIO1	GPIO	ALT0	GPIO1.IO[8]	Input with PD
GPIO1_IO09	AF10	NVCC_GPIO1	GPIO	ALT1	GPIO1.IO[9]	Input with PD
GPIO1_IO10	AD10	NVCC_GPIO1	GPIO	ALT0	GPIO1.IO[10]	Input with PD
GPIO1_IO11	AC10	NVCC_GPIO1	GPIO	ALT0	GPIO1.IO[11]	Input with PD
GPIO1_IO12	AB10	NVCC_GPIO1	GPIO	ALT0	GPIO1.IO[12]	Input with PD
GPIO1_IO13	AD9	NVCC_GPIO1	GPIO	ALT0	GPIO1.IO[13]	Input with PD
GPIO1_IO14	AC9	NVCC_GPIO1	GPIO	ALT0	GPIO1.IO[14]	Input with PD
GPIO1_IO15	AB9	NVCC_GPIO1	GPIO	ALT0	GPIO1.IO[15]	Input with PD
I2C1_SCL	E9	NVCC_I2C	GPIO	ALT5	GPIO5.IO[14]	Input with PD
I2C1_SDA	F9	NVCC_I2C	GPIO	ALT5	GPIO5.IO[15]	Input with PD
I2C2_SCL	D10	NVCC_I2C	GPIO	ALT5	GPIO5.IO[16]	Input with PD
I2C2_SDA	D9	NVCC_I2C	GPIO	ALT5	GPIO5.IO[17]	Input with PD
I2C3_SCL	E10	NVCC_I2C	GPIO	ALT5	GPIO5.IO[18]	Input with PD
I2C3_SDA	F10	NVCC_I2C	GPIO	ALT5	GPIO5.IO[19]	Input with PD
I2C4_SCL	D13	NVCC_I2C	GPIO	ALT5	GPIO5.IO[20]	Input with PD
I2C4_SDA	E13	NVCC_I2C	GPIO	ALT5	GPIO5.IO[21]	Input with PD
JTAG_MOD	D27	NVCC_JTAG	GPIO	ALT0	cjtag_wrapper.MOD	Input with PD
JTAG_TCK	F26	NVCC_JTAG	GPIO	ALT0	cjtag_wrapper.TCK	Input with PU
JTAG_TDI	E27	NVCC_JTAG	GPIO	ALT0	cjtag_wrapper.TDI	Input with PU
JTAG_TDO	E26	NVCC_JTAG	GPIO	ALT0	cjtag_wrapper.TDO	Input with PU
JTAG_TMS ²	F27	NVCC_JTAG	GPIO	ALT0	cjtag_wrapper.TMS	Input with PU
MIPI_CSI_CLK_N	A16	VDD_MIPI_1P8	PHY	—	—	Input
MIPI_CSI_CLK_P	B16	VDD_MIPI_1P8	PHY	—	—	Input
MIPI_CSI_D0_N	A14	VDD_MIPI_1P8	PHY	—	—	Input

Table 75. i.MX 8M Nano 14 x 14 mm functional contact assignments (continued)

Ball name	Ball	Power group	Ball type	Reset condition		
				Default mode	Default function	Input/Output status
MIPI_CSI_D0_P	B14	VDD_MIPI_1P8	PHY	—	—	Input
MIPI_CSI_D1_N	A15	VDD_MIPI_1P8	PHY	—	—	Input
MIPI_CSI_D1_P	B15	VDD_MIPI_1P8	PHY	—	—	Input
MIPI_CSI_D2_N	A17	VDD_MIPI_1P8	PHY	—	—	Input
MIPI_CSI_D2_P	B17	VDD_MIPI_1P8	PHY	—	—	Input
MIPI_CSI_D3_N	A18	VDD_MIPI_1P8	PHY	—	—	Input
MIPI_CSI_D3_P	B18	VDD_MIPI_1P8	PHY	—	—	Input
MIPI_DSI_CLK_N	A11	VDD_MIPI_1P8	PHY	—	—	Output low
MIPI_DSI_CLK_P	B11	VDD_MIPI_1P8	PHY	—	—	Output low
MIPI_DSI_D0_N	A9	VDD_MIPI_1P8	PHY	—	—	Output low
MIPI_DSI_D0_P	B9	VDD_MIPI_1P8	PHY	—	—	Output low
MIPI_DSI_D1_N	A10	VDD_MIPI_1P8	PHY	—	—	Output low
MIPI_DSI_D1_P	B10	VDD_MIPI_1P8	PHY	—	—	Output low
MIPI_DSI_D2_N	A12	VDD_MIPI_1P8	PHY	—	—	Output low
MIPI_DSI_D2_P	B12	VDD_MIPI_1P8	PHY	—	—	Output low
MIPI_DSI_D3_N	A13	VDD_MIPI_1P8	PHY	—	—	Output low
MIPI_DSI_D3_P	B13	VDD_MIPI_1P8	PHY	—	—	Output low
MIPI_VREG_CAP	D15	0.35 - 0.45 V	PHY	—	—	Output
NAND_ALE	N22	NVCC_NAND	GPIO	ALT5	GPIO3.IO[0]	Input with PD
NAND_CE0_B	N24	NVCC_NAND	GPIO	ALT5	GPIO3.IO[1]	Input with PD
NAND_CE1_B	P27	NVCC_NAND	GPIO	ALT5	GPIO3.IO[2]	Input with PD
NAND_CE2_B	M27	NVCC_NAND	GPIO	ALT5	GPIO3.IO[3]	Input with PD
NAND_CE3_B	L27	NVCC_NAND	GPIO	ALT5	GPIO3.IO[4]	Input with PD
NAND_CLE	K27	NVCC_NAND	GPIO	ALT5	GPIO3.IO[5]	Input with PD
NAND_DATA00	P23	NVCC_NAND	GPIO	ALT5	GPIO3.IO[6]	Input with PD
NAND_DATA01	K24	NVCC_NAND	GPIO	ALT5	GPIO3.IO[7]	Input with PD
NAND_DATA02	K23	NVCC_NAND	GPIO	ALT5	GPIO3.IO[8]	Input with PD
NAND_DATA03	N23	NVCC_NAND	GPIO	ALT5	GPIO3.IO[9]	Input with PD
NAND_DATA04	M26	NVCC_NAND	GPIO	ALT5	GPIO3.IO[10]	Input with PD
NAND_DATA05	L26	NVCC_NAND	GPIO	ALT5	GPIO3.IO[11]	Input with PD

Table 75. i.MX 8M Nano 14 x 14 mm functional contact assignments (continued)

Ball name	Ball	Power group	Ball type	Reset condition		
				Default mode	Default function	Input/Output status
NAND_DATA06	K26	NVCC_NAND	GPIO	ALT5	GPIO3.IO[12]	Input with PD
NAND_DATA07	N26	NVCC_NAND	GPIO	ALT5	GPIO3.IO[13]	Input with PD
NAND_DQS	R22	NVCC_NAND	GPIO	ALT5	GPIO3.IO[14]	Input with PD
NAND_RE_B	N27	NVCC_NAND	GPIO	ALT5	GPIO3.IO[15]	Input with PD
NAND_READY_B	P26	NVCC_NAND	GPIO	ALT5	GPIO3.IO[16]	Input with PD
NAND_WE_B	R26	NVCC_NAND	GPIO	ALT5	GPIO3.IO[17]	Input with PD
NAND_WP_B	R27	NVCC_NAND	GPIO	ALT5	GPIO3.IO[18]	Input with PD
ONOFF	A25	NVCC_SNVS_1P8	GPIO	ALT0	snvsmix.ONOFF	Input without PU/PD
PMIC_ON_REQ	A24	NVCC_SNVS_1P8	GPIO	ALT0	snvsmix.PMIC_ON_REQ	Open-drain output high with PU
PMIC_STBY_REQ	E24	NVCC_SNVS_1P8	GPIO	ALT0	ccmsrcgpcmix.PMIC_STBY_REQ	Output low with PD
POR_B	B24	NVCC_SNVS_1P8	GPIO	ALT0	snvsmix.POR_B	Input without PU/PD
RTC_XTALI	A26	NVCC_SNVS_1P8	ANALOG	ALT0	snvsmix.RTC	Input
RTC_XTALO	B25	NVCC_SNVS_1P8	ANALOG	—	—	Output, inverted of RTC_XTALI
RTC_RESET_B	F24	NVCC_SNVS_1P8	GPIO	ALT0	snvsmix.RTC_POR_B	Input without PU/PD
SAI2_MCLK	AD19	NVCC_SAI2	GPIO	ALT5	GPIO4.IO[27]	Input with PD
SAI2_RXC	AB22	NVCC_SAI2	GPIO	ALT5	GPIO4.IO[22]	Input with PD
SAI2_RXD0	AC24	NVCC_SAI2	GPIO	ALT5	GPIO4.IO[23]	Input with PD
SAI2_RXFS	AC19	NVCC_SAI2	GPIO	ALT5	GPIO4.IO[21]	Input with PD
SAI2_TXC	AD22	NVCC_SAI2	GPIO	ALT5	GPIO4.IO[25]	Input with PD
SAI2_TXD0	AC22	NVCC_SAI2	GPIO	ALT5	GPIO4.IO[26]	Input with PD
SAI2_TXFS	AD23	NVCC_SAI2	GPIO	ALT5	GPIO4.IO[24]	Input with PD
SAI3_MCLK	AD6	NVCC_SAI3	GPIO	ALT5	GPIO5.IO[2]	Input with PD
SAI3_RXC	AG7	NVCC_SAI3	GPIO	ALT5	GPIO4.IO[29]	Input with PD
SAI3_RXD	AF7	NVCC_SAI3	GPIO	ALT5	GPIO4.IO[30]	Input with PD
SAI3_RXFS	AG8	NVCC_SAI3	GPIO	ALT5	GPIO4.IO[28]	Input with PD

Table 75. i.MX 8M Nano 14 x 14 mm functional contact assignments (continued)

Ball name	Ball	Power group	Ball type	Reset condition		
				Default mode	Default function	Input/Output status
SAI3_TXC	AG6	NVCC_SAI3	GPIO	ALT5	GPIO5.IO[0]	Input with PD
SAI3_TXD	AF6	NVCC_SAI3	GPIO	ALT5	GPIO5.IO[1]	Input with PD
SAI3_TXFS	AC6	NVCC_SAI3	GPIO	ALT5	GPIO4.IO[31]	Input with PD
SAI5_MCLK	AD15	NVCC_SAI5	GPIO	ALT5	GPIO3.IO[25]	3
SAI5_RXC	AC15	NVCC_SAI5	GPIO	ALT5	GPIO3.IO[20]	Input with PD
SAI5_RXD0	AD18	NVCC_SAI5	GPIO	ALT5	GPIO3.IO[21]	Input with PD
SAI5_RXD1	AC14	NVCC_SAI5	GPIO	ALT5	GPIO3.IO[22]	Input with PD
SAI5_RXD2	AD13	NVCC_SAI5	GPIO	ALT5	GPIO3.IO[23]	Input with PD
SAI5_RXD3	AC13	NVCC_SAI5	GPIO	ALT5	GPIO3.IO[24]	Input with PD
SAI5_RXFS	AB15	NVCC_SAI5	GPIO	ALT5	GPIO3.IO[19]	Input with PD
SD1_CLK	V26	NVCC_SD1	GPIO	ALT5	GPIO2.IO[0]	Input with PD
SD1_CMD	V27	NVCC_SD1	GPIO	ALT5	GPIO2.IO[1]	Input with PD
SD1_DATA0	Y27	NVCC_SD1	GPIO	ALT5	GPIO2.IO[2]	Input with PD
SD1_DATA1	Y26	NVCC_SD1	GPIO	ALT5	GPIO2.IO[3]	Input with PD
SD1_DATA2	T27	NVCC_SD1	GPIO	ALT5	GPIO2.IO[4]	Input with PD
SD1_DATA3	T26	NVCC_SD1	GPIO	ALT5	GPIO2.IO[5]	Input with PD
SD1_DATA4	U27	NVCC_SD1	GPIO	ALT5	GPIO2.IO[6]	Input with PD
SD1_DATA5	U26	NVCC_SD1	GPIO	ALT5	GPIO2.IO[7]	Input with PD
SD1_DATA6	W27	NVCC_SD1	GPIO	ALT5	GPIO2.IO[8]	Input with PD
SD1_DATA7	W26	NVCC_SD1	GPIO	ALT5	GPIO2.IO[9]	Input with PD
SD1_RESET_B	R23	NVCC_SD1	GPIO	ALT5	GPIO2.IO[10]	Input with PD
SD1_STROBE	R24	NVCC_SD1	GPIO	ALT5	GPIO2.IO[11]	Input with PD
SD2_CD_B	AA26	NVCC_SD2	GPIO	ALT5	GPIO2.IO[12]	Input with PD
SD2_CLK	W23	NVCC_SD2	GPIO	ALT5	GPIO2.IO[13]	Input with PD
SD2_CMD	W24	NVCC_SD2	GPIO	ALT5	GPIO2.IO[14]	Input with PD
SD2_DATA0	AB23	NVCC_SD2	GPIO	ALT5	GPIO2.IO[15]	Input with PD
SD2_DATA1	AB24	NVCC_SD2	GPIO	ALT5	GPIO2.IO[16]	Input with PD
SD2_DATA2	V24	NVCC_SD2	GPIO	ALT5	GPIO2.IO[17]	Input with PD
SD2_DATA3	V23	NVCC_SD2	GPIO	ALT5	GPIO2.IO[18]	Input with PD
SD2_RESET_B	AB26	NVCC_SD2	GPIO	ALT5	GPIO2.IO[19]	Input with PD

Table 75. i.MX 8M Nano 14 x 14 mm functional contact assignments (continued)

Ball name	Ball	Power group	Ball type	Reset condition		
				Default mode	Default function	Input/Output status
SD2_WP	AA27	NVCC_SD2	GPIO	ALT5	GPIO2.IO[20]	Input with PD
SPDIF_EXT_CLK	AF8	NVCC_SAI3	GPIO	ALT5	GPIO5.IO[5]	Input with PD
SPDIF_RX	AG9	NVCC_SAI3	GPIO	ALT5	GPIO5.IO[4]	Input with PD
SPDIF_TX	AF9	NVCC_SAI3	GPIO	ALT5	GPIO5.IO[3]	Input with PD
TSENSOR_TEST_OUT	J23	VDD_ANA1_1P8	ANALOG	—	—	Output low
TSENSOR_RES_EXT	J24	VDD_ANA1_1P8	ANALOG	—	—	—
UART1_RXD	E14	NVCC_UART	GPIO	ALT5	GPIO5.IO[22]	Input with PD
UART1_TXD	F13	NVCC_UART	GPIO	ALT5	GPIO5.IO[23]	Input with PD
UART2_RXD	F15	NVCC_UART	GPIO	ALT5	GPIO5.IO[24]	Input with PD
UART2_TXD	E15	NVCC_UART	GPIO	ALT5	GPIO5.IO[25]	Input with PD
UART3_RXD	E18	NVCC_UART	GPIO	ALT5	GPIO5.IO[26]	Input with PD
UART3_TXD	D18	NVCC_UART	GPIO	ALT5	GPIO5.IO[27]	Input with PD
UART4_RXD	F19	NVCC_UART	GPIO	ALT5	GPIO5.IO[28]	Input with PD
UART4_TXD	F18	NVCC_UART	GPIO	ALT5	GPIO5.IO[29]	Input with PD
USB1_DN	A22	VDD_USB_3P3	PHY	—	—	Input
USB1_DP	B22	VDD_USB_3P3	PHY	—	—	Input
USB1_ID	D22	VDD_USB_1P8	PHY	—	—	Input
USB1_TXRTUNE	E19	VDD_USB_1P8	PHY	—	—	—
USB1_VBUS	F22	VDD_USB_3P3	PHY	—	—	—

¹ During reset: output high without PU/PD; After reset: input with PU

² Mandatory requirement: JTAG_TMS pin must be connected with a 50 ohm serial resistor near the component.

³ During reset: input without PU/PD; After reset: input with PD

5.1.3 i.MX 8M Nano 14 x 14 mm 0.5 mm pitch ball map

Table 76 shows the i.MX 8M Nano 14 x 14 mm 0.5 mm pitch ball map.

Table 76. 14 x 14 mm, 0.5 mm pitch ball map

	G	F	E	D	C	B	A
	DRAM_DQS1_P	DRAM_DM1	DRAM_DQ14	DRAM_DQ03	DRAM_DQ04	DRAM_DQ05	VSS
	DRAM_DQ09	DRAM_DQ08	DRAM_DQ15	DRAM_DQ02	VSS	DRAM_DQS0_N	DRAM_DQS0_P
		VSS	VSS			VSS	DRAM_DQ06
		DRAM_AC00	DRAM_AC10			DRAM_DQ07	DRAM_DM0
		DRAM_AC01		DRAM_AC11	VSS	DRAM_DQ01	DRAM_DQ00
		DRAM_AC06	ECSPI2_SCLK	ECSPI1_SCLK	VSS	ECSPI1_SS0	ECSPI2_SS0
	VSS					ECSPI1_MOSI	ECSPI1_MISO
						ECSPI2_MOSI	ECSPI2_MISO
	VSS	I2C1_SDA	I2C1_SCL	I2C2_SDA	VSS	MIPI_DSI_D0_P	MIPI_DSI_D0_N
	VSS	I2C3_SDA	I2C3_SCL	I2C2_SCL	VSS	MIPI_DSI_D1_P	MIPI_DSI_D1_N
						MIPI_DSI_CLK_P	MIPI_DSI_CLK_N
						MIPI_DSI_D2_P	MIPI_DSI_D2_N
	VSS	UART1_TXD	I2C4_SDA	I2C4_SCL	VSS	MIPI_DSI_D3_P	MIPI_DSI_D3_N
			UART1_RXD		VSS	MIPI_CSI_D0_P	MIPI_CSI_D0_N
	VSS	UART2_RXD	UART2_TXD	MIPI_VREG_CAP	VSS	MIPI_CSI_D1_P	MIPI_CSI_D1_N
						MIPI_CSI_CLK_P	MIPI_CSI_CLK_N
						MIPI_CSI_D2_P	MIPI_CSI_D2_N
	VSS	UART4_TXD	UART3_RXD	UART3_TXD	VSS	MIPI_CSI_D3_P	MIPI_CSI_D3_N
	VSS	UART4_RXD	USB1_TXRTUNE		VSS		
	VSS						
		USB1_VBUS		USB1_ID	VSS	USB1_DP	USB1_DN
					VSS		
		RTC_RESET_B	PMIC_STBY_REQ			POR_B	PMIC_ON_REQ
		VSS	VSS			RTC_XTALO	ONOFF
	BOOT_MODE0	JTAG_TCK	JTAG_TDO	BOOT_MODE3	24M_XTALO	VSS	RTC_XTALI
	BOOT_MODE1	JTAG_TMS	JTAG_TDI	JTAG_MOD	BOOT_MODE2	24M_XTALI	VSS

Table 76. 14 x 14 mm, 0.5 mm pitch ball map (continued)

P	N	M	L	K	J	H
DRAM_VREF	DRAM_AC26	DRAM_AC16	DRAM_AC05	DRAM_DQ13	DRAM_DQ10	DRAM_DQS1_N
DRAM_ZN	DRAM_AC19	DRAM_AC17	DRAM_AC04	DRAM_DQ12	DRAM_DQ11	VSS
VSS	VSS			VSS	VSS	
VDD_DRAM_PLL_1P8	DRAM_AC12			DRAM_AC02	DRAM_AC03	
	DRAM_AC13			DRAM_AC14	DRAM_AC07	
	DRAM_AC15			DRAM_AC09	DRAM_AC08	
NVCC_DRAM	VSS			VSS	VSS	
	NVCC_DRAM			NVCC_DRAM		
VDD_DRAM_PLL_0P8	NVCC_DRAM	NVCC_DRAM	NVCC_DRAM	NVCC_DRAM		
	VDD_DRAM		VDD_DRAM		VDD_DRAM	NVCC_ECSP1
					NVCC_I2C	
VDD_GPU	VSS	VSS	VSS		NVCC_UART	
VSS	VDD_SOC				PVCC2_1P8	VDD_MIPI_1P8
					VDD_MIPI_0P8	
VSS	VDD_SOC	VDD_SOC	VDD_SOC	VDD_SOC	VDD_MIPI_1P2	VDD_USB_1P8
VDD_ARM_PLL_0P8	VSS	VSS	VSS	VDD_SOC		
	VDD_ANA_0P8		VDD_ANA_0P8		VDD_USB_0P8	
	VDD_SOC		VDD_SOC			VSS
VDD_ANA1_1P8	VDD_24M_XTAL_1P8	NVCC_CLK	NVCC_JTAG	VDD_USB_3P3		
	VDD_ANA1_1P8			VSS		
VSS	VSS			VSS	VSS	
	NAND_ALE			VDD_SNV5_0P8	NVCC_SNV5_1P8	
NAND_DATA00	NAND_DATA03			NAND_DATA02	SENSOR_TEST_OUT	
	NAND_CE0_B			NAND_DATA01	SENSOR_RES_EXT	
VSS	VSS			VSS	VSS	
NAND_READY_B	NAND_DATA07	NAND_DATA04	NAND_DATA05	NAND_DATA06	CLKOUT2	CLKOUT1
NAND_CE1_B	NAND_RE_B	NAND_CE2_B	NAND_CE3_B	NAND_CLE	CLKIN2	CLKIN1

Table 76. 14 x 14 mm, 0.5 mm pitch ball map (continued)

AB	AA	Y	W	V	U	T	R
					DRAM_AC25	DRAM_AC34	DRAM_RESET_N
		VSS			DRAM_AC24	DRAM_AC35	DRAM_ALERT_N
VSS			VSS	VSS			VSS
DRAM_AC20			DRAM_AC22	DRAM_AC23			DRAM_AC32
DRAM_AC21			DRAM_AC37	DRAM_AC36			DRAM_AC33
DRAM_AC38			DRAM_AC28	DRAM_AC29			DRAM_AC27
	VSS		VSS	VSS			VSS
				NVCC_DRAM			NVCC_DRAM
GPIO1_IO15	VSS			NVCC_DRAM	NVCC_DRAM	NVCC_DRAM	NVCC_DRAM
GPIO1_IO12	VSS	NVCC_SAI3	VDD_DRAM		VDD_DRAM		VDD_DRAM
			VDD_GPU		VDD_GPU		VDD_GPU
			NVCC_GPIO1	VDD_GPU	VSS	VSS	VSS
PVCC0_1P8	VSS	VSS	VDD_ARM	VDD_ARM	VDD_ARM	VDD_ARM	VDD_ARM
	VDD_ANA0_1P8		VDD_ARM			VDD_ARM	
SAI5_RXFS	VSS	VDD_ANA0_1P8	VDD_ARM	VDD_ARM	VDD_ARM	VDD_ARM	VDD_ARM
			VDD_ARM	VDD_ARM	VSS	VSS	VSS
			NVCC_SAI5		VDD_SOC		VDD_SOC
	VSS	VSS			VDD_SOC		VDD_SOC
	VSS			NVCC_SAI2	NVCC_NAND	PVCC1_1P8	VDD_ARM_PLL_1P8
				NVCC_SD1			VSS
	VSS		VSS	VSS			VSS
SAI2_RXC			NVCC_ENET	NVCC_SD2			NAND_DQS
SD2_DATA0			SD2_CLK	SD2_DATA3			SD1_RESET_B
SD2_DATA1			SD2_CMD	SD2_DATA2			SD1_STROBE
VSS			VSS	VSS			VSS
SD2_RESET_B	SD2_CD_B	SD1_DATA1	SD1_DATA7	SD1_CLK	SD1_DATA5	SD1_DATA3	NAND_WE_B
ENET_MDIO	SD2_WP	SD1_DATA0	SD1_DATA6	SD1_CMD	SD1_DATA4	SD1_DATA2	NAND_WP_B

5.2 11 x 11 mm package information

5.2.1 11 x 11 mm, 0.5 mm pitch, ball matrix

Figure 50 shows the top, bottom, and side views of the 11 × 11 mm FCBGA package.

FC-PBGA-306 I/O
11 X 11 X 0.91 PKG, 0.5 PITCH, MOLDED ARRAY

SOT2064-1

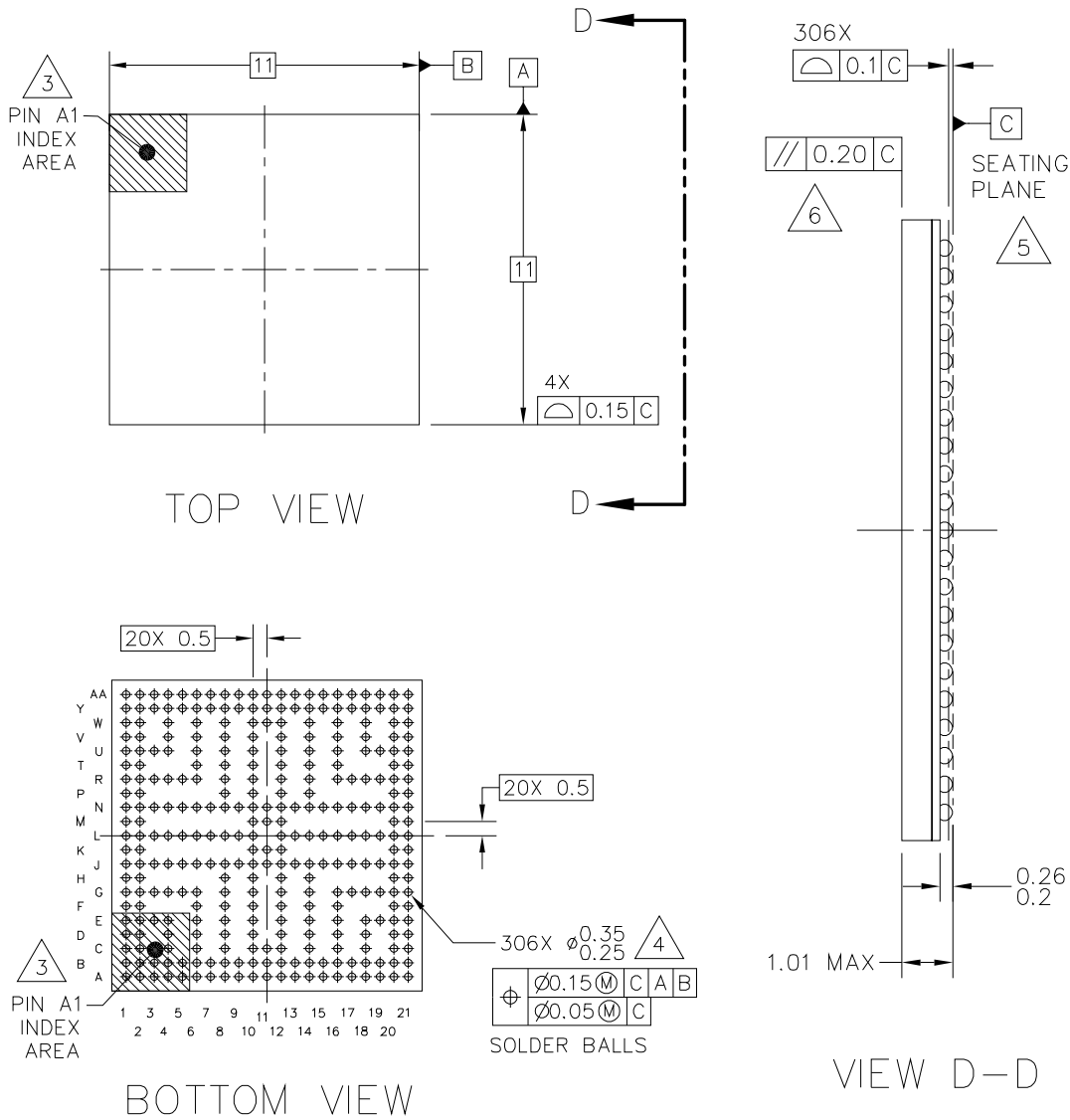

© NXP B.V. ALL RIGHTS RESERVED

DATE: 22 JAN 2021

MECHANICAL OUTLINE PRINT VERSION NOT TO SCALE	STANDARD: NON JEDEC	DRAWING NUMBER: 98ASA01587D	REVISION: 0	PAGE: 1 OF 5
--	------------------------	--------------------------------	----------------	-----------------

Figure 50. 11 X 11 MM BGA, case x package top, bottom, and side views

5.2.2 11 x 11 mm supplies contact assignments and functional contact assignments

Table 77 shows supplies contact assignments for the 11 x 11 mm package.

Table 77. i.MX 8M Nano 11 x 11 mm supplies contact assignments

Supply Rail Name	Ball(s) Position(s)	Remark
NVCC_CLK_JTAG_PVCC_1P8	L15	Supply for CLK, JTAG interface and Digital I/O pre-drive
NVCC_DRAM	G6, J6, J7, L6, N6, N7, R6	Supply for DRAM interface
NVCC_ECSPi	G8	Supply for ECSPi interface
NVCC_ENET_GPIO_SAI2	R12	Supply for ENET, GPIO1, and SAI2 interface
NVCC_I2C_UART	G10	Supply for I2C and UART interface
NVCC_SAI3_SAI5	R10	Supply for SAI3 and SAI5 interface
NVCC_SD1_NAND	N15	Supply for SD1 and NAND interface
NVCC_SD2	R16	Supply for SD interface
NVCC_SNVs_1P8	G14	Supply for SNVs interface
VDD_ANA1_XTAL_MIPI_USB_1P8	G12	Supply for XTAL, Analog logic, MIPI, and USB 1.8 V
VDD_ANA0_ARM_PLL_1P8	R14	Supply for Analog logic and ARM PLL 1.8 V
VDD_DRAM_PLL_1P8	L7	Supply for DRAM PLL
VDD_MIPI_1P2	F12	Supply for MIPI PHY
VDD_SNVs_0P8	J15	Supply for SNVs logic
VDD_SOC	J9, J10, J11, J12, J13, K10, K12, L9, L10, L12, L13, M10, M12, N9, N10, N11, N12, N13	Supply for SOC logic
VDD_USB_3P3	F14	Supply for USB PHY
VSS	A1, AA1, E3, G3, J3, L3, N3, R3, U3, C4, W4, C6, W6, C8, H8, J8, L8, N8, P8, W8, C10, H10, P10, W10, K11, M11, C12, H12, P12, W12, C14, H14, J14, L14, N14, P14, W14, C16, W16, C18, W18, E19, G19, J19, L19, N19, R19, U19, B20, A21, AA21	—

Table 78 shows an alpha-sorted list of functional contact assignments for the 11 x 11 mm package.

Table 78. i.MX 8M Nano 11 x 11 mm functional contact assignments

Ball name	Ball	Power group	Ball type	Reset condition		
				Default mode	Default function	Input/Output status
24M_XTALI	B21	NVCC_CLK_JTAG_PVCC_1P8	ANALOG	—	—	Input
24M_XTALO	C20	NVCC_CLK_JTAG_PVCC_1P8	ANALOG	—	—	Output
BOOT_MODE0	G16	NVCC_CLK_JTAG_PVCC_1P8	GPIO	ALT0	ccmsrcgpcmix.BOOT_MODE[0]	Input with PD
BOOT_MODE1	G18	NVCC_CLK_JTAG_PVCC_1P8	GPIO	ALT0	ccmsrcgpcmix.BOOT_MODE[1]	Input with PD
BOOT_MODE2	F16	NVCC_CLK_JTAG_PVCC_1P8	GPIO	ALT0	ccmsrcgpcmix.BOOT_MODE[2]	Input with PD
BOOT_MODE3	G17	NVCC_CLK_JTAG_PVCC_1P8	GPIO	ALT0	ccmsrcgpcmix.BOOT_MODE[3]	Input with PD
CLKIN1	E20	NVCC_CLK_JTAG_PVCC_1P8	GPIO	—	—	Input without PU/PD
CLKIN2	F20	NVCC_CLK_JTAG_PVCC_1P8	GPIO	—	—	Input without PU/PD
CLKOUT1	E21	NVCC_CLK_JTAG_PVCC_1P8	GPIO	—	—	Output low without PU/PD
CLKOUT2	F21	NVCC_CLK_JTAG_PVCC_1P8	GPIO	—	—	Output low without PU/PD
DRAM_AC00	P1	NVCC_DRAM	DDR	—	—	Output low
DRAM_AC01	N1	NVCC_DRAM	DDR	—	—	Output low
DRAM_AC02	N2	NVCC_DRAM	DDR	—	—	Input
DRAM_AC03	P2	NVCC_DRAM	DDR	—	—	Input
DRAM_AC04	G5	NVCC_DRAM	DDR	—	—	Input
DRAM_AC05	G4	NVCC_DRAM	DDR	—	—	Input
DRAM_AC06	D4	NVCC_DRAM	DDR	—	—	Input
DRAM_AC07	E4	NVCC_DRAM	DDR	—	—	Input
DRAM_AC08	R1	NVCC_DRAM	DDR	—	—	Input
DRAM_AC09	R2	NVCC_DRAM	DDR	—	—	Input
DRAM_AC10	M2	NVCC_DRAM	DDR	—	—	Input

Table 78. i.MX 8M Nano 11 x 11 mm functional contact assignments (continued)

Ball name	Ball	Power group	Ball type	Reset condition		
				Default mode	Default function	Input/Output status
DRAM_AC11	L2	NVCC_DRAM	DDR	—	—	Input
DRAM_AC12	L1	NVCC_DRAM	DDR	—	—	Input
DRAM_AC13	M1	NVCC_DRAM	DDR	—	—	Input
DRAM_AC14	Y1	NVCC_DRAM	DDR	—	—	Input
DRAM_AC15	L5	NVCC_DRAM	DDR	—	—	Input
DRAM_AC16	J4	NVCC_DRAM	DDR	—	—	Input
DRAM_AC17	J5	NVCC_DRAM	DDR	—	—	Input
DRAM_AC20	T1	NVCC_DRAM	DDR	—	—	Output low
DRAM_AC21	T2	NVCC_DRAM	DDR	—	—	Output low
DRAM_AC23	R4	NVCC_DRAM	DDR	—	—	Input
DRAM_AC24	Y2	NVCC_DRAM	DDR	—	—	Input
DRAM_AC25	AA2	NVCC_DRAM	DDR	—	—	Input
DRAM_AC26	W2	NVCC_DRAM	DDR	—	—	Input
DRAM_AC28	AA3	NVCC_DRAM	DDR	—	—	Input
DRAM_AC29	V4	NVCC_DRAM	DDR	—	—	Input
DRAM_AC30	W1	NVCC_DRAM	DDR	—	—	Input
DRAM_AC31	Y3	NVCC_DRAM	DDR	—	—	Input
DRAM_AC32	R5	NVCC_DRAM	DDR	—	—	Input
DRAM_AC33	U2	NVCC_DRAM	DDR	—	—	Input
DRAM_AC34	V2	NVCC_DRAM	DDR	—	—	Input
DRAM_AC35	U4	NVCC_DRAM	DDR	—	—	Input
DRAM_AC36	V1	NVCC_DRAM	DDR	—	—	Input
DRAM_ALERT_N	N5	NVCC_DRAM	DDR	—	—	Input
DRAM_DM0	B2	NVCC_DRAM	DDR	—	—	Input
DRAM_DM1	H2	NVCC_DRAM	DDR	—	—	Input
DRAM_DQ00	B3	NVCC_DRAM	DDR	—	—	Input
DRAM_DQ01	A2	NVCC_DRAM	DDR	—	—	Input
DRAM_DQ02	A3	NVCC_DRAM	DDR	—	—	Input
DRAM_DQ03	B4	NVCC_DRAM	DDR	—	—	Input
DRAM_DQ04	E2	NVCC_DRAM	DDR	—	—	Input

Table 78. i.MX 8M Nano 11 x 11 mm functional contact assignments (continued)

Ball name	Ball	Power group	Ball type	Reset condition		
				Default mode	Default function	Input/Output status
DRAM_DQ05	D1	NVCC_DRAM	DDR	—	—	Input
DRAM_DQ06	C1	NVCC_DRAM	DDR	—	—	Input
DRAM_DQ07	D2	NVCC_DRAM	DDR	—	—	Input
DRAM_DQ08	G1	NVCC_DRAM	DDR	—	—	Input
DRAM_DQ09	H1	NVCC_DRAM	DDR	—	—	Input
DRAM_DQ10	J1	NVCC_DRAM	DDR	—	—	Input
DRAM_DQ11	J2	NVCC_DRAM	DDR	—	—	Input
DRAM_DQ12	K1	NVCC_DRAM	DDR	—	—	Input
DRAM_DQ13	K2	NVCC_DRAM	DDR	—	—	Input
DRAM_DQ14	F2	NVCC_DRAM	DDR	—	—	Input
DRAM_DQ15	E1	NVCC_DRAM	DDR	—	—	Input
DRAM_DQS0_N	C2	NVCC_DRAM	—	—	—	Input
DRAM_DQS0_P	B1	NVCC_DRAM	DDRCLK	—	—	Input
DRAM_DQS1_N	F1	NVCC_DRAM	—	—	—	Input
DRAM_DQS1_P	G2	NVCC_DRAM	DDRCLK	—	—	Input
DRAM_RESET_N	N4	NVCC_DRAM	DDR	—	—	Output low
DRAM_VREF	L4	NVCC_DRAM	DDR	—	—	—
DRAM_ZN	U1	NVCC_DRAM	DDR	—	—	—
ECSPI1_MISO	D6	NVCC_ECSPi	GPIO	ALT5	GPIO5.IO[8]	Input with PD
ECSPI1_MOSI	F6	NVCC_ECSPi	GPIO	ALT5	GPIO5.IO[7]	Input with PD
ECSPI1_SCLK	E6	NVCC_ECSPi	GPIO	ALT5	GPIO5.IO[6]	Input with PD
ECSPI1_SS0	B6	NVCC_ECSPi	GPIO	ALT5	GPIO5.IO[9]	Input with PD
ECSPI2_MISO	B5	NVCC_ECSPi	GPIO	ALT5	GPIO5.IO[12]	Input with PD
ECSPI2_MOSI	A6	NVCC_ECSPi	GPIO	ALT5	GPIO5.IO[11]	Input with PD
ECSPI2_SCLK	A4	NVCC_ECSPi	GPIO	ALT5	GPIO5.IO[10]	Input with PD
ECSPI2_SS0	A5	NVCC_ECSPi	GPIO	ALT5	GPIO5.IO[13]	Input with PD
ENET_MDC	Y18	NVCC_ENET_GPI O_SAI2	GPIO	ALT5	GPIO1.IO[16]	Input with PD
ENET_MDIO	T16	NVCC_ENET_GPI O_SAI2	GPIO	ALT5	GPIO1.IO[17]	Input with PD

Table 78. i.MX 8M Nano 11 x 11 mm functional contact assignments (continued)

Ball name	Ball	Power group	Ball type	Reset condition		
				Default mode	Default function	Input/ Output status
ENET_RD0	AA19	NVCC_ENET_GPI O_SAI2	GPIO	ALT5	GPIO1.IO[26]	Input with PD
ENET_RD1	Y15	NVCC_ENET_GPI O_SAI2	GPIO	ALT5	GPIO1.IO[27]	Input with PD
ENET_RD2	Y16	NVCC_ENET_GPI O_SAI2	GPIO	ALT5	GPIO1.IO[28]	Input with PD
ENET_RD3	AA16	NVCC_ENET_GPI O_SAI2	GPIO	ALT5	GPIO1.IO[29]	Input with PD
ENET_RXC	U16	NVCC_ENET_GPI O_SAI2	GPIO	ALT5	GPIO1.IO[25]	Input with PD
ENET_RX_CTL	V16	NVCC_ENET_GPI O_SAI2	GPIO	ALT5	GPIO1.IO[24]	Input with PD
ENET_TD0	U18	NVCC_ENET_GPI O_SAI2	GPIO	ALT5	GPIO1.IO[21]	Input with PD
ENET_TD1	AA18	NVCC_ENET_GPI O_SAI2	GPIO	ALT5	GPIO1.IO[20]	Input with PD
ENET_TD2	V18	NVCC_ENET_GPI O_SAI2	GPIO	ALT5	GPIO1.IO[19]	Input with PD
ENET_TD3	AA17	NVCC_ENET_GPI O_SAI2	GPIO	ALT5	GPIO1.IO[18]	Input with PD
ENET_TXC	Y19	NVCC_ENET_GPI O_SAI2	GPIO	ALT5	GPIO1.IO[23]	Input with PD
ENET_TX_CTL	Y17	NVCC_ENET_GPI O_SAI2	GPIO	ALT5	GPIO1.IO[22]	Input with PD
GPIO1_IO00	V8	NVCC_ENET_GPI O_SAI2	GPIO	ALT6	GPIO1.IO[0]	Input with PD
GPIO1_IO01	R8	NVCC_ENET_GPI O_SAI2	GPIO	ALT6	GPIO1.IO[1]	1
GPIO1_IO02	AA8	NVCC_ENET_GPI O_SAI2	GPIO	ALT0	GPIO1.IO[2]	Input with PU
GPIO1_IO03	Y9	NVCC_ENET_GPI O_SAI2	GPIO	ALT0	GPIO1.IO[3]	Input with PD
GPIO1_IO04	AA7	NVCC_ENET_GPI O_SAI2	GPIO	ALT0	GPIO1.IO[4]	Input with PD
GPIO1_IO05	T8	NVCC_ENET_GPI O_SAI2	GPIO	ALT6	GPIO1.IO[5]	1
GPIO1_IO06	Y8	NVCC_ENET_GPI O_SAI2	GPIO	ALT0	GPIO1.IO[6]	Input with PD

Table 78. i.MX 8M Nano 11 x 11 mm functional contact assignments (continued)

Ball name	Ball	Power group	Ball type	Reset condition		
				Default mode	Default function	Input/Output status
GPIO1_IO07	U8	NVCC_ENET_GPIO_SAI2	GPIO	ALT0	GPIO1.IO[7]	Input with PD
GPIO1_IO08	V10	NVCC_ENET_GPIO_SAI2	GPIO	ALT0	GPIO1.IO[8]	Input with PD
GPIO1_IO09	AA9	NVCC_ENET_GPIO_SAI2	GPIO	ALT1	GPIO1.IO[9]	Input with PD
GPIO1_IO10	AA10	NVCC_ENET_GPIO_SAI2	GPIO	ALT0	GPIO1.IO[10]	Input with PD
GPIO1_IO11	Y11	NVCC_ENET_GPIO_SAI2	GPIO	ALT0	GPIO1.IO[11]	Input with PD
GPIO1_IO12	U10	NVCC_ENET_GPIO_SAI2	GPIO	ALT0	GPIO1.IO[12]	Input with PD
GPIO1_IO13	T10	NVCC_ENET_GPIO_SAI2	GPIO	ALT0	GPIO1.IO[13]	Input with PD
GPIO1_IO14	Y10	NVCC_ENET_GPIO_SAI2	GPIO	ALT0	GPIO1.IO[14]	Input with PD
GPIO1_IO15	AA11	NVCC_ENET_GPIO_SAI2	GPIO	ALT0	GPIO1.IO[15]	Input with PD
I2C1_SCL	B7	NVCC_I2C_UART	GPIO	ALT5	GPIO5.IO[14]	Input with PD
I2C1_SDA	A7	NVCC_I2C_UART	GPIO	ALT5	GPIO5.IO[15]	Input with PD
I2C2_SCL	F10	NVCC_I2C_UART	GPIO	ALT5	GPIO5.IO[16]	Input with PD
I2C2_SDA	D8	NVCC_I2C_UART	GPIO	ALT5	GPIO5.IO[17]	Input with PD
I2C3_SCL	F8	NVCC_I2C_UART	GPIO	ALT5	GPIO5.IO[18]	Input with PD
I2C3_SDA	E8	NVCC_I2C_UART	GPIO	ALT5	GPIO5.IO[19]	Input with PD
I2C4_SCL	B8	NVCC_I2C_UART	GPIO	ALT5	GPIO5.IO[20]	Input with PD
I2C4_SDA	A8	NVCC_I2C_UART	GPIO	ALT5	GPIO5.IO[21]	Input with PD
JTAG_MOD	D18	NVCC_CLK_JTAG_PVCC_1P8	GPIO	ALT0	cjtag_wrapper.MOD	Input with PD
JTAG_TCK	D21	NVCC_CLK_JTAG_PVCC_1P8	GPIO	ALT0	cjtag_wrapper.TCK	Input with PU
JTAG_TDI	C21	NVCC_CLK_JTAG_PVCC_1P8	GPIO	ALT0	cjtag_wrapper.TDI	Input with PU
JTAG_TDO	D20	NVCC_CLK_JTAG_PVCC_1P8	GPIO	ALT0	cjtag_wrapper.TDO	Input with PU
JTAG_TMS ²	E18	NVCC_CLK_JTAG_PVCC_1P8	GPIO	ALT0	cjtag_wrapper.TMS	Input with PU

Table 78. i.MX 8M Nano 11 x 11 mm functional contact assignments (continued)

Ball name	Ball	Power group	Ball type	Reset condition		
				Default mode	Default function	Input/Output status
MIPI_CSI_CLK_N	A13	VDD_ANA1_XTAL_MIPUSB_1P8	PHY	—	—	Input
MIPI_CSI_CLK_P	B13	VDD_ANA1_XTAL_MIPUSB_1P8	PHY	—	—	Input
MIPI_CSI_D0_N	A11	VDD_ANA1_XTAL_MIPUSB_1P8	PHY	—	—	Input
MIPI_CSI_D0_P	B11	VDD_ANA1_XTAL_MIPUSB_1P8	PHY	—	—	Input
MIPI_CSI_D1_N	A12	VDD_ANA1_XTAL_MIPUSB_1P8	PHY	—	—	Input
MIPI_CSI_D1_P	B12	VDD_ANA1_XTAL_MIPUSB_1P8	PHY	—	—	Input
MIPI_CSI_D2_N	A14	VDD_ANA1_XTAL_MIPUSB_1P8	PHY	—	—	Input
MIPI_CSI_D2_P	B14	VDD_ANA1_XTAL_MIPUSB_1P8	PHY	—	—	Input
MIPI_CSI_D3_N	A15	VDD_ANA1_XTAL_MIPUSB_1P8	PHY	—	—	Input
MIPI_CSI_D3_P	B15	VDD_ANA1_XTAL_MIPUSB_1P8	PHY	—	—	Input
MIPI_VREG_CAP	D12	0.35 - 0.45 V	PHY	—	—	Output
NAND_ALE	J17	NVCC_SD1_NAND	GPIO	ALT5	GPIO3.IO[0]	Input with PD
NAND_CE0_B	L21	NVCC_SD1_NAND	GPIO	ALT5	GPIO3.IO[1]	Input with PD
NAND_CE1_B	H20	NVCC_SD1_NAND	GPIO	ALT5	GPIO3.IO[2]	Input with PD
NAND_CE2_B	L16	NVCC_SD1_NAND	GPIO	ALT5	GPIO3.IO[3]	Input with PD
NAND_CE3_B	L20	NVCC_SD1_NAND	GPIO	ALT5	GPIO3.IO[4]	Input with PD
NAND_CLE	K20	NVCC_SD1_NAND	GPIO	ALT5	GPIO3.IO[5]	Input with PD
NAND_DATA00	M21	NVCC_SD1_NAND	GPIO	ALT5	GPIO3.IO[6]	Input with PD
NAND_DATA01	J20	NVCC_SD1_NAND	GPIO	ALT5	GPIO3.IO[7]	Input with PD
NAND_DATA02	M20	NVCC_SD1_NAND	GPIO	ALT5	GPIO3.IO[8]	Input with PD
NAND_DATA03	K21	NVCC_SD1_NAND	GPIO	ALT5	GPIO3.IO[9]	Input with PD
NAND_DATA04	L18	NVCC_SD1_NAND	GPIO	ALT5	GPIO3.IO[10]	Input with PD
NAND_DATA05	J18	NVCC_SD1_NAND	GPIO	ALT5	GPIO3.IO[11]	Input with PD
NAND_DATA06	N20	NVCC_SD1_NAND	GPIO	ALT5	GPIO3.IO[12]	Input with PD

Table 78. i.MX 8M Nano 11 x 11 mm functional contact assignments (continued)

Ball name	Ball	Power group	Ball type	Reset condition		
				Default mode	Default function	Input/Output status
NAND_DATA07	G20	NVCC_SD1_NAND	GPIO	ALT5	GPIO3.IO[13]	Input with PD
NAND_DQS	H21	NVCC_SD1_NAND	GPIO	ALT5	GPIO3.IO[14]	Input with PD
NAND_RE_B	G21	NVCC_SD1_NAND	GPIO	ALT5	GPIO3.IO[15]	Input with PD
NAND_READY_B	L17	NVCC_SD1_NAND	GPIO	ALT5	GPIO3.IO[16]	Input with PD
NAND_WE_B	J16	NVCC_SD1_NAND	GPIO	ALT5	GPIO3.IO[17]	Input with PD
NAND_WP_B	J21	NVCC_SD1_NAND	GPIO	ALT5	GPIO3.IO[18]	Input with PD
ONOFF	E14	NVCC_SNV5_1P8	GPIO	ALT0	snvsmix.ONOFF	Input without PU/PD
PMIC_ON_REQ	E16	NVCC_SNV5_1P8	GPIO	ALT0	snvsmix.PMIC_ON_REQ	Open-drain output high with PU
PMIC_STBY_REQ	A19	NVCC_SNV5_1P8	GPIO	ALT0	ccmsrcgpcmix.PMIC_STBY_REQ	Output low with PD
POR_B	A18	NVCC_SNV5_1P8	GPIO	ALT0	snvsmix.POR_B	Input without PU/PD
RTC_XTALI	A20	NVCC_SNV5_1P8	ANALOG	ALT0	snvsmix.RTC	Input
RTC_XTALO	B19	NVCC_SNV5_1P8	ANALOG	—	—	Output, inverted of RTC_XTALI
RTC_RESET_B	B18	NVCC_SNV5_1P8	GPIO	ALT0	snvsmix.RTC_POR_B	Input without PU/PD
SAI2_MCLK	Y12	NVCC_ENET_GPI O_SAI2	GPIO	ALT5	GPIO4.IO[27]	Input with PD
SAI2_RXC	AA15	NVCC_ENET_GPI O_SAI2	GPIO	ALT5	GPIO4.IO[22]	Input with PD
SAI2_RXD0	AA14	NVCC_ENET_GPI O_SAI2	GPIO	ALT5	GPIO4.IO[23]	Input with PD
SAI2_RXFS	Y13	NVCC_ENET_GPI O_SAI2	GPIO	ALT5	GPIO4.IO[21]	Input with PD
SAI2_TXC	AA13	NVCC_ENET_GPI O_SAI2	GPIO	ALT5	GPIO4.IO[25]	Input with PD
SAI2_TXD0	Y14	NVCC_ENET_GPI O_SAI2	GPIO	ALT5	GPIO4.IO[26]	Input with PD
SAI2_TXFS	AA12	NVCC_ENET_GPI O_SAI2	GPIO	ALT5	GPIO4.IO[24]	Input with PD
SAI3_MCLK	AA5	NVCC_SAI3_SAI5	GPIO	ALT5	GPIO5.IO[2]	Input with PD

Table 78. i.MX 8M Nano 11 x 11 mm functional contact assignments (continued)

Ball name	Ball	Power group	Ball type	Reset condition		
				Default mode	Default function	Input/Output status
SAI3_RXC	Y6	NVCC_SAI3_SAI5	GPIO	ALT5	GPIO4.IO[29]	Input with PD
SAI3_RXD	AA6	NVCC_SAI3_SAI5	GPIO	ALT5	GPIO4.IO[30]	Input with PD
SAI3_RXFS	Y4	NVCC_SAI3_SAI5	GPIO	ALT5	GPIO4.IO[28]	Input with PD
SAI3_TXC	Y5	NVCC_SAI3_SAI5	GPIO	ALT5	GPIO5.IO[0]	Input with PD
SAI3_TXD	AA4	NVCC_SAI3_SAI5	GPIO	ALT5	GPIO5.IO[1]	Input with PD
SAI3_TXFS	Y7	NVCC_SAI3_SAI5	GPIO	ALT5	GPIO4.IO[31]	Input with PD
SAI5_MCLK	W11	NVCC_SAI3_SAI5	GPIO	ALT5	GPIO3.IO[25]	3
SAI5_RXC	V14	NVCC_SAI3_SAI5	GPIO	ALT5	GPIO3.IO[20]	Input with PD
SAI5_RXD0	U12	NVCC_SAI3_SAI5	GPIO	ALT5	GPIO3.IO[21]	Input with PD
SAI5_RXD1	T14	NVCC_SAI3_SAI5	GPIO	ALT5	GPIO3.IO[22]	Input with PD
SAI5_RXD2	V12	NVCC_SAI3_SAI5	GPIO	ALT5	GPIO3.IO[23]	Input with PD
SAI5_RXD3	U14	NVCC_SAI3_SAI5	GPIO	ALT5	GPIO3.IO[24]	Input with PD
SAI5_RXFS	T12	NVCC_SAI3_SAI5	GPIO	ALT5	GPIO3.IO[19]	Input with PD
SD1_CLK	R21	NVCC_SD1_NAND	GPIO	ALT5	GPIO2.IO[0]	Input with PD
SD1_CMD	T21	NVCC_SD1_NAND	GPIO	ALT5	GPIO2.IO[1]	Input with PD
SD1_DATA0	N18	NVCC_SD1_NAND	GPIO	ALT5	GPIO2.IO[2]	Input with PD
SD1_DATA1	N17	NVCC_SD1_NAND	GPIO	ALT5	GPIO2.IO[3]	Input with PD
SD1_DATA2	N21	NVCC_SD1_NAND	GPIO	ALT5	GPIO2.IO[4]	Input with PD
SD1_DATA3	P20	NVCC_SD1_NAND	GPIO	ALT5	GPIO2.IO[5]	Input with PD
SD1_DATA4	P21	NVCC_SD1_NAND	GPIO	ALT5	GPIO2.IO[6]	Input with PD
SD1_DATA5	T20	NVCC_SD1_NAND	GPIO	ALT5	GPIO2.IO[7]	Input with PD
SD1_DATA6	R20	NVCC_SD1_NAND	GPIO	ALT5	GPIO2.IO[8]	Input with PD
SD1_DATA7	N16	NVCC_SD1_NAND	GPIO	ALT5	GPIO2.IO[9]	Input with PD
SD1_RESET_B	R18	NVCC_SD1_NAND	GPIO	ALT5	GPIO2.IO[10]	Input with PD
SD1_STROBE	R17	NVCC_SD1_NAND	GPIO	ALT5	GPIO2.IO[11]	Input with PD
SD2_CD_B	U20	NVCC_SD2	GPIO	ALT5	GPIO2.IO[12]	Input with PD
SD2_CLK	Y21	NVCC_SD2	GPIO	ALT5	GPIO2.IO[13]	Input with PD
SD2_CMD	V21	NVCC_SD2	GPIO	ALT5	GPIO2.IO[14]	Input with PD
SD2_DATA0	AA20	NVCC_SD2	GPIO	ALT5	GPIO2.IO[15]	Input with PD
SD2_DATA1	U21	NVCC_SD2	GPIO	ALT5	GPIO2.IO[16]	Input with PD

Table 78. i.MX 8M Nano 11 x 11 mm functional contact assignments (continued)

Ball name	Ball	Power group	Ball type	Reset condition		
				Default mode	Default function	Input/Output status
SD2_DATA2	W20	NVCC_SD2	GPIO	ALT5	GPIO2.IO[17]	Input with PD
SD2_DATA3	V20	NVCC_SD2	GPIO	ALT5	GPIO2.IO[18]	Input with PD
SD2_RESET_B	Y20	NVCC_SD2	GPIO	ALT5	GPIO2.IO[19]	Input with PD
SD2_WP	W21	NVCC_SD2	GPIO	ALT5	GPIO2.IO[20]	Input with PD
SPDIF_EXT_CLK	T6	NVCC_SAI3_SAI5	GPIO	ALT5	GPIO5.IO[5]	Input with PD
SPDIF_RX	U6	NVCC_SAI3_SAI5	GPIO	ALT5	GPIO5.IO[4]	Input with PD
SPDIF_TX	V6	NVCC_SAI3_SAI5	GPIO	ALT5	GPIO5.IO[3]	Input with PD
TSENSOR_RES_EXT	D16	VDD_ANA1_XTAL_MIPi_USB_1P8	ANALOG	—	—	—
UART1_RXD	A9	NVCC_I2C_UART	GPIO	ALT5	GPIO5.IO[22]	Input with PD
UART1_TXD	E10	NVCC_I2C_UART	GPIO	ALT5	GPIO5.IO[23]	Input with PD
UART2_RXD	B9	NVCC_I2C_UART	GPIO	ALT5	GPIO5.IO[24]	Input with PD
UART2_TXD	C11	NVCC_I2C_UART	GPIO	ALT5	GPIO5.IO[25]	Input with PD
UART3_RXD	B10	NVCC_I2C_UART	GPIO	ALT5	GPIO5.IO[26]	Input with PD
UART3_TXD	E12	NVCC_I2C_UART	GPIO	ALT5	GPIO5.IO[27]	Input with PD
UART4_RXD	A10	NVCC_I2C_UART	GPIO	ALT5	GPIO5.IO[28]	Input with PD
UART4_TXD	D10	NVCC_I2C_UART	GPIO	ALT5	GPIO5.IO[29]	Input with PD
USB1_DN	A17	VDD_USB_3P3	PHY	—	—	Input
USB1_DP	B17	VDD_USB_3P3	PHY	—	—	Input
USB1_ID	D14	VDD_ANA1_XTAL_MIPi_USB_1P8	PHY	—	—	Input
USB1_TXRTUNE	B16	VDD_ANA1_XTAL_MIPi_USB_1P8	PHY	—	—	—
USB1_VBUS	A16	VDD_USB_3P3	PHY	—	—	—

¹ During reset: output high without PU/PD; After reset: input with PU

² Mandatory requirement: JTAG_TMS pin must be connected with a 50 ohm serial resistor near the component.

³ During reset: input without PU/PD; After reset: input with PD

5.2.3 i.MX 8M Nano 11 x 11 mm 0.5 mm pitch ball map

Table 79 shows the i.MX 8M Nano 11 x 11 mm 0.5 mm pitch ball map.

Table 79. 11 x 11 mm, 0.5 mm pitch ball map

	1	2	3	4	5	6	7	8	9	10	11	12	13	14	15	16	17	18	19	20	21
F	E	D	C	B	A																
DRAM_DQS1_N	DRAM_DQ15	DRAM_DQ05	DRAM_DQ06	DRAM_DQS0_P	VSS																
DRAM_DQ14	DRAM_DQ04	DRAM_DQ07	DRAM_DQS0_N	DRAM_DM0	DRAM_DQ01																
	VSS			DRAM_DQ00	DRAM_DQ02																
	DRAM_AC07	DRAM_AC06	VSS	DRAM_DQ03	ECSPI2_SCLK																
				ECSPI2_MISO	ECSPI2_SS0																
ECSPI1_MOSI	ECSPI1_SCLK	ECSPI1_MISO	VSS	ECSPI1_SS0	ECSPI2_MOSI																
				I2C1_SCL	I2C1_SDA																
I2C3_SCL	I2C3_SDA	I2C2_SDA	VSS	I2C4_SCL	I2C4_SDA																
				UART2_RXD	UART1_RXD																
I2C2_SCL	UART1_TXD	UART4_TXD	VSS	UART3_RXD	UART4_RXD																
			UART2_TXD	MIPI_CSI_D0_P	MIPI_CSI_D0_N																
VDD_MIPI_1P2	UART3_TXD	MIPI_VREG_CAP	VSS	MIPI_CSI_D1_P	MIPI_CSI_D1_N																
				MIPI_CSI_CLK_P	MIPI_CSI_CLK_N																
VDD_USB_3P3	ONOFF	USB1_ID	VSS	MIPI_CSI_D2_P	MIPI_CSI_D2_N																
				MIPI_CSI_D3_P	MIPI_CSI_D3_N																
BOOT_MODE2	PMIC_ON_REQ	TSSENSOR_RES_EXT	VSS	USB1_TXRTUNE	USB1_VBUS																
				USB1_DP	USB1_DN																
	JTAG_TMS	JTAG_MOD	VSS	RTC_RESET_B	POR_B																
	VSS			RTC_XTALO	PMIC_STBY_REQ																
CLKIN2	CLKIN1	JTAG_TDO	24M_XTALO	VSS	RTC_XTALI																
CLKOUT2	CLKOUT1	JTAG_TCK	JTAG_TDI	24M_XTALI	VSS																

Table 79. 11 x 11 mm, 0.5 mm pitch ball map (continued)

	1	2	3	4	5	6	7	8	9	10	11	12	13	14	15	16	17	18	19	20	21
W	V	U	T	R	P	N															
DRAM_AC30	DRAM_AC36	DRAM_ZN	DRAM_AC20	DRAM_AC08	DRAM_AC00	DRAM_AC01															
DRAM_AC26	DRAM_AC34	DRAM_AC33	DRAM_AC21	DRAM_AC09	DRAM_AC03	DRAM_AC02															
		VSS		VSS		VSS															
VSS	DRAM_AC29	DRAM_AC35		DRAM_AC23		DRAM_RESET_N															
VSS	SPDIF_TX	SPDIF_RX	SPDIF_EXT_CLK	NVCC_DRAM		NVCC_DRAM															
VSS	GPIO1_IO00	GPIO1_IO07	GPIO1_IO05	GPIO1_IO01	VSS	VSS															
VSS	GPIO1_IO08	GPIO1_IO12	GPIO1_IO13	NVCC_SAI3_SAI5	VSS	VDD_SOC															
SAI5_MCLK						VDD_SOC															
VSS	SAI5_RXD2	SAI5_RXD0	SAI5_RXFS	NVCC_ENET_GPIO_SAI2	VSS	VDD_SOC															
VSS	SAI5_RXC	SAI5_RXD3	SAI5_RXD1	VDD_ANA0_ARM_PLL_1P8	VSS	VDD_SOC															
VSS	ENET_RX_CTL	ENET_RXC	ENET_MDIO	NVCC_SD2		NVCC_SD1_NAND															
VSS	ENET_TD2	ENET_TD0		SD1_STROBE		SD1_DATA7															
		VSS		SD1_RESET_B		SD1_DATA0															
SD2_DATA2	SD2_DATA3	SD2_CD_B	SD1_DATA5	VSS		VSS															
SD2_WP	SD2_CMD	SD2_DATA1	SD1_CMD	SD1_CLK	SD1_DATA4	SD1_DATA2															

Table 79. 11 x 11 mm, 0.5 mm pitch ball map (continued)

	1	2	3	4	5	6	7	8	9	10	11	12	13	14	15	16	17	18	19	20	21
Y	DRAM_AC14	DRAM_AC24	DRAM_AC31	SAI3_RXFS	SAI3_TXC	SAI3_RXC	SAI3_TXFS	GPIO1_IO06	GPIO1_IO03	GPIO1_IO14	GPIO1_IO11	SAI2_MCLK	SAI2_RXFS	SAI2_TXD0	ENET_RD1	ENET_RD2	ENET_TX_CTL	ENET_MDC	ENET_TXC	SD2_RESET_B	SD2_CLK
AA	VSS	DRAM_AC25	DRAM_AC28	SAI3_TXD	SAI3_MCLK	SAI3_RXD	GPIO1_IO04	GPIO1_IO02	GPIO1_IO09	GPIO1_IO10	GPIO1_IO15	SAI2_TXFS	SAI2_TXC	SAI2_RXD0	SAI2_RXC	ENET_RD3	ENET_TD3	ENET_TD1	ENET_RD0	SD2_DATA0	VSS

5.3 DDR pin function list

Table 80 shows the DDR pin function list.

Table 80. DDR pin function list

Ball name	LPDDR4	DDR4	DDR3/3L
DRAM_DQS0_P	DQS0_t_A	DQSL_t_A	DQSL_A
DRAM_DQS0_N	DQS0_c_A	DQSL_c_A	DQSL#_A
DRAM_DM0	DMI0_A	DML_n_A / DBIL_n_A	DML_A
DRAM_DQ00	DQ0_A	DQL0_A	DQL0_A
DRAM_DQ01	DQ1_A	DQL1_A	DQL1_A
DRAM_DQ02	DQ2_A	DQL2_A	DQL2_A
DRAM_DQ03	DQ3_A	DQL3_A	DQL3_A
DRAM_DQ04	DQ4_A	DQL4_A	DQL4_A
DRAM_DQ05	DQ5_A	DQL5_A	DQL5_A
DRAM_DQ06	DQ6_A	DQL6_A	DQL6_A
DRAM_DQ07	DQ7_A	DQL7_A	DQL7_A
DRAM_DQS1_P	DQS1_t_A	DQSU_t_A	DQSU_A
DRAM_DQS1_N	DQS1_c_A	DQSU_c_A	DQSU#_A
DRAM_DM1	DMI1_A	DMU_n_A / DBIU_n_A	DMU_A
DRAM_DQ08	DQ08_A	DQU0_A	DQU0_A
DRAM_DQ09	DQ09_A	DQU1_A	DQU1_A
DRAM_DQ10	DQ10_A	DQU2_A	DQU2_A
DRAM_DQ11	DQ11_A	DQU3_A	DQU3_A
DRAM_DQ12	DQ12_A	DQU4_A	DQU4_A
DRAM_DQ13	DQ13_A	DQU5_A	DQU5_A

Table 80. DDR pin function list (continued)

DRAM_DQ14	DQ14_A	DQU6_A	DQU6_A
DRAM_DQ15	DQ15_A	DQU7_A	DQU7_A
DRAM_RESET_N	RESET_N	RESET_n	RESET#
DRAM_ALERT_N	MTEST1	ALERT_n / MTEST1	MTEST1
DRAM_AC00	CKE0_A	CKE0	CKE0
DRAM_AC01	CKE1_A	CKE1	CKE1
DRAM_AC02	CS0_A	CS0_n	CS0#
DRAM_AC03	CS1_A	C0	—
DRAM_AC04	CK_t_A	BG0	BA2
DRAM_AC05	CK_c_A	BG1	A14
DRAM_AC06	—	ACT_n	A15
DRAM_AC07	—	A9	A9
DRAM_AC08	CA0_A	A12	A12 / BC#
DRAM_AC09	CA1_A	A11	A11
DRAM_AC10	CA2_A	A7	A7
DRAM_AC11	CA3_A	A8	A8
DRAM_AC12	CA4_A	A6	A6
DRAM_AC13	CA5_A	A5	A5
DRAM_AC14	—	A4	A4
DRAM_AC15	—	A3	A3
DRAM_AC16	—	CK_t_A	CK_A
DRAM_AC17	—	CK_c_A	CK#_A
DRAM_AC19	MTEST	MTEST	MTEST
DRAM_AC20	CKE0_B	CK_t_B	CK_B
DRAM_AC21	CKE1_B	CK_c_B	CK#_B
DRAM_AC22	CS1_B	—	—
DRAM_AC23	CS0_B	—	—
DRAM_AC24	CK_t_B	A2	A2
DRAM_AC25	CK_c_B	A1	A1
DRAM_AC26	—	BA1	BA1
DRAM_AC27	—	PARITY	—
DRAM_AC28	CA0_B	A13	A13
DRAM_AC29	CA1_B	BA0	BA0
DRAM_AC30	CA2_B	A10 / AP	A10 / AP

Table 80. DDR pin function list (continued)

DRAM_AC31	CA3_B	A0	A0
DRAM_AC32	CA4_B	C2	—
DRAM_AC33	CA5_B	CAS_n / A15	CAS#
DRAM_AC34	—	WE_n / A14	WE#
DRAM_AC35	—	RAS_n / A16	RAS#
DRAM_AC36	—	ODT0	ODT0
DRAM_AC37	—	ODT1	ODT1
DRAM_AC38	—	CS1_n	CS1#
DRAM_ZN	ZQ	ZQ	ZQ
DRAM_VREF	VREF	VREF	VREF

6 Revision history

Table 81 provides a revision history for this data sheet.

Table 81. Revision history

Rev.number	Date	Substantive change(s)
Rev. 1	03/2021	<ul style="list-style-type: none"> • Updated the M7 frequency in the Chapter 1, i.MX 8M Nano introduction • Added a note for the Figure 1, "i.MX 8M Nano system block diagram" and Table 2, "Modules supported" • Added part numbers for 11 x 11 mm package and descriptions in the Table 3, "Orderable part numbers" • Updated the package type and part differentiator in the Figure 2, "Part number nomenclature—i.MX 8M Nano family of processors" • Updated the LCDIF descriptions in the Table 4, "i.MX 8M Nano modules list" • Updated the Section 2.1, Recommended connections for unused input/output • Updated the title and the maximum values of VDD_ARM_PLL_0P8 and VDD_USB_0P8 in the Table 10, "Absolute maximum ratings for 14 x 14 mm package" • Added the Table 11, "Absolute maximum ratings for 11 x 11 mm package" • Updated the title of Table 13, "14 x 14 mm package thermal resistance data" • Added the new Section 3.1.2.2, 11 x 11 mm FCBGA package thermal resistance • Updated the VDD_ANA_0P8, VDD_ARM_PLL_0P8, VDD_MIPI_0P8, VDD_USB_0P8, VDD_DRAM_PLL_0P8, and USB1_VBUS in the Table 15, "Operating ranges for 14 x 14 mm package" • Added the Table 16, "Operating ranges for 11 x 11 mm package" • Updated the title of Table 19, "Estimated power supply maximum currents for 14 x 14 mm package" • Added the Table 20, "Estimated power supply maximum currents for 11 x 11 mm package" • Updated and added Low-V suspend mode data in the Table 21, "Chip power in different LP mode for 14 x 14 mm package" • Added the Table 22, "Chip power in different LP mode for 11 x 11 mm package" • Updated and added a foot note in the Table 23, "The power supply states for 14 x 14 mm package" • Added the Table 25, "The power supply states for 11 x 11 mm package" • Updated POR_B and added a note for Figure 3, "The power-up sequence for 14 x 14 mm package" • Updated the T13 descriptions in the Table 26, "Power-up sequence for 14 x 14 mm package" • Added the Figure 4, "The power-up sequence for 11 x 11 mm package" and Table 27, "Power-up sequence for 11 x 11 mm package" • Updated the titles of Figure 5, "The power-down sequence for 14 x 14 mm package" and Table 28, "Power-down sequence for 14 x 14 mm package" • Added the Figure 6, "The power-down sequence for 11 x 11 mm package" and Table 29, "Power-down sequence for 11 x 11 mm package" • Removed the Section, Power supplies constraints • Updated the lock time and GPU values in the Table 30, "PLL electrical parameters"; added the M7_ALT_PLL in the Table 30, "PLL electrical parameters" • Fixed a typo in the Table 74, "i.MX 8M Nano 14 x 14 mm supplies contact assignments" • Changed the name of TSENSOR_RES_EXT in the Table 75, "i.MX 8M Nano 14 x 14 mm functional contact assignments"; updated the input/out status of GPIO1_IO07, NAND_CE0_B, and NAND_RE_B in the Table 75, "i.MX 8M Nano 14 x 14 mm functional contact assignments" • Updated the names of H10, M1, and W22 in the Table 76, "14 x 14 mm, 0.5 mm pitch ball map" • Added the Section 5.2, 11 x 11 mm package information

Table 81. Revision history (continued)

Rev.number	Date	Substantive change(s)
Rev. 1	02/2021	<ul style="list-style-type: none">Updated LPDDR4 information of DRAM_AC14 and DRAMAC34 in the Table 80, "DDR pin function list"
Rev. 0.1	03/2020	<ul style="list-style-type: none">Updated the Table, "Power supplies constraints"
Rev. 0	10/2019	<ul style="list-style-type: none">Initial version

How To Reach Us

Home Page:

nxp.com

Web Support:

nxp.com/support

Limited warranty and liability — Information in this document is believed to be accurate and reliable. However, NXP Semiconductors does not give any representations or warranties, expressed or implied, as to the accuracy or completeness of such information and shall have no liability for the consequences of use of such information. NXP Semiconductors takes no responsibility for the content in this document if provided by an information source outside of NXP Semiconductors. In no event shall NXP Semiconductors be liable for any indirect, incidental, punitive, special or consequential damages (including - without limitation - lost profits, lost savings, business interruption, costs related to the removal or replacement of any products or rework charges) whether or not such damages are based on tort (including negligence), warranty, breach of contract or any other legal theory.

Notwithstanding any damages that customer might incur for any reason whatsoever, NXP Semiconductors' aggregate and cumulative liability towards customer for the products described herein shall be limited in accordance with the Terms and conditions of commercial sale of NXP Semiconductors.

Right to make changes - NXP Semiconductors reserves the right to make changes to information published in this document, including without limitation specifications and product descriptions, at any time and without notice. This document supersedes and replaces all information supplied prior to the publication hereof.

Security — Customer understands that all NXP products may be subject to unidentified or documented vulnerabilities. Customer is responsible for the design and operation of its applications and products throughout their lifecycles to reduce the effect of these vulnerabilities on customer's applications and products. Customer's responsibility also extends to other open and/or proprietary technologies supported by NXP products for use in customer's applications. NXP accepts no liability for any vulnerability. Customer should regularly check security updates from NXP and follow up appropriately.

Customer shall select products with security features that best meet rules, regulations, and standards of the intended application and make the ultimate design decisions regarding its products and is solely responsible for compliance with all legal, regulatory, and security related requirements concerning its products, regardless of any information or support that may be provided by NXP. NXP has a Product Security Incident Response Team (PSIRT) (reachable at PSIRT@nxp.com) that manages the investigation, reporting, and solution release to security vulnerabilities of NXP products.

Suitability for use — NXP Semiconductors products are not designed, authorized or warranted to be suitable for use in life support, life-critical or safety-critical systems or equipment, nor in applications where failure or malfunction of an NXP Semiconductors product can reasonably be expected to result in personal injury, death or severe property or environmental damage. NXP Semiconductors and its suppliers accept no liability for inclusion and/or use of NXP Semiconductors products in such equipment or applications and therefore such inclusion and/or use is at the customer's own risk.

Applications — Applications that are described herein for any of these products are for illustrative purposes only. NXP Semiconductors makes no representation or warranty that such applications will be suitable for the specified use without further testing or modification.

Customers are responsible for the design and operation of their applications and products using NXP Semiconductors products, and NXP Semiconductors accepts no liability for any assistance with applications or customer product design. It is customer's sole responsibility to determine whether the NXP Semiconductors product is suitable and fit for the customer's applications and products planned, as well as for the planned application and use of customer's third party customer(s). Customers should provide appropriate design and operating safeguards to minimize the risks associated with their applications and products.

NXP Semiconductors does not accept any liability related to any default, damage, costs or problem which is based on any weakness or default in the customer's applications or products, or the application or use by customer's third party customer(s). Customer is responsible for doing all necessary testing for the customer's applications and products using NXP Semiconductors products in order to avoid a default of the applications and the products or of the application or use by customer's third party customer(s). NXP does not accept any liability in this respect.

Hazardous voltage — Although basic supply voltages of the product may be much lower, circuit voltages up to 60 V may appear when operating this product, depending on settings and application. Customers incorporating or otherwise

Table continues on the next page...

using these products in applications where such high voltages may appear during operation, assembly, test etc. of such application, do so at their own risk. Customers agree to fully indemnify NXP Semiconductors for any damages resulting from or in connection with such high voltages. Furthermore, customers are drawn to safety standards (IEC 950, EN 60 950, CENELEC, ISO, etc.) and other (legal) requirements applying to such high voltages.

Evaluation products —This product is provided on an “as is” and “with all faults” basis for evaluation purposes only. NXP Semiconductors, its affiliates and their suppliers expressly disclaim all warranties, whether express, implied or statutory, including but not limited to the implied warranties of non-infringement, merchantability and fitness for a particular purpose. The entire risk as to the quality, or arising out of the use or performance, of this product remains with customer. In no event shall NXP Semiconductors, its affiliates or their suppliers be liable to customer for any special, indirect, consequential, punitive or incidental damages (including without limitation damages for loss of business, business interruption, loss of use, loss of data or information, and the like) arising out the use of or inability to use the product, whether or not based on tort (including negligence), strict liability, breach of contract, breach of warranty or any other theory, even if advised of the possibility of such damages.

Notwithstanding any damages that customer might incur for any reason whatsoever (including without limitation, all damages referenced above and all direct or general damages), the entire liability of NXP Semiconductors, its affiliates and their suppliers and customer’s exclusive remedy for all of the foregoing shall be limited to actual damages incurred by customer based on reasonable reliance up to the greater of the amount actually paid by customer for the product or five dollars (US\$5.00). The foregoing limitations, exclusions and disclaimers shall apply to the maximum extent permitted by applicable law, even if any remedy fails of its essential purpose.

Translations — A non-English (translated) version of a document is for reference only. The English version shall prevail in case of any discrepancy between the translated and English versions.

NXP, the NXP logo, NXP SECURE CONNECTIONS FOR A SMARTER WORLD, COOLFLUX, EMBRACE, GREENCHIP, HITAG, ICODE, JCOP, LIFE, VIBES, MIFARE, MIFARE CLASSIC, MIFARE DESFire, MIFARE PLUS, MIFARE FLEX, MANTIS, MIFARE ULTRALIGHT, MIFARE4MOBILE, MIGLO, NTAG, ROADLINK, SMARTLX, SMARTMX, STARPLUG, TOPFET, TRENCHMOS, UCODE, Freescale, the Freescale logo, Altivec, CodeWarrior, ColdFire, ColdFire+, the Energy Efficient Solutions logo, Kinetis, Layerscape, MagniV, mobileGT, PEG, PowerQUICC, Processor Expert, QorIQ, QorIQ Qonverge, SafeAssure, the SafeAssure logo, StarCore, Symphony, VortiQa, Vybrid, Airfast, BeeKit, BeeStack, CoreNet, Flexis, MXC, Platform in a Package, QUICC Engine, Tower, TurboLink, EdgeScale, EdgeLock, eiQ, and Immersive3D are trademarks of NXP B.V. All other product or service names are the property of their respective owners. AMBA, Arm, Arm7, Arm7TDMI, Arm9, Arm11, Artisan, big.LITTLE, Cordio, CoreLink, CoreSight, Cortex, DesignStart, DynamIQ, Jazelle, Keil, Mali, Mbed, Mbed Enabled, NEON, POP, RealView, SecurCore, Socrates, Thumb, TrustZone, ULINK, ULINK2, ULINK-ME, ULINK-PLUS, ULINKpro, μ Vision, Versatile are trademarks or registered trademarks of Arm Limited (or its subsidiaries) in the US and/or elsewhere. The related technology may be protected by any or all of patents, copyrights, designs and trade secrets. All rights reserved. Oracle and Java are registered trademarks of Oracle and/or its affiliates. M, M Mobileye and other Mobileye trademarks or logos appearing herein are trademarks of Mobileye Vision Technologies Ltd. in the United States, the EU and/or other jurisdictions.

© NXP B.V. 2021.

All rights reserved.

For more information, please visit: <http://www.nxp.com>

For sales office addresses, please send an email to: salesaddresses@nxp.com

Date of release: April, 2021

Document identifier: IMX8MNIIEC



Mouser Electronics

Authorized Distributor

Click to View Pricing, Inventory, Delivery & Lifecycle Information:

[NXP:](#)

[MIMX8MN1CVTIZAA](#) [MIMX8MN2CVTIZAA](#) [MIMX8MN3CVTIZAA](#) [MIMX8MN4CVTIZAA](#) [MIMX8MN5CVTIZAA](#)
[MIMX8MN6CVTIZAA](#) [MIMX8MN2CVTIZAAR](#) [MIMX8MN1CVPIZAA](#) [MIMX8MN3CVPIZAA](#) [MIMX8MN5CVPIZAA](#)

Looking for pricing, stock, or lifecycle information?

Click below to explore more details on WIN SOURCE:

 [View MIMX8MN5CVTIZAA on WIN SOURCE](#)

 [NXP / Nexperia Information](#)

Optimize Your Supply Chain with WIN SOURCE Solutions

-  Global Sourcing Solution
-  Obsolete Management
-  Cost Control Management
-  Shortage Management
-  Alternative Solution
-  Excess Inventory Management