



# DRV8770: 100-V Brushed DC Gate Driver

## 1 Features

- 100-V H-bridge gate driver
  - Drives N-channel MOSFETs (NMOS)
  - Gate driver supply (GVDD): 5-20 V
  - MOSFET supply (SHx) support up to 100 V
- Integrated bootstrap diodes
- Supports inverting and non-inverting INLx inputs (QFN package)
- Bootstrap gate drive architecture
  - 750-mA source current
  - 1.5-A Sink current
- Supports up to 15s battery powered applications
- Low leakage current on SHx pins (<55  $\mu$ A)
- Absolute maximum BSTx voltage upto 115-V
- Supports negative transients down to -22 V on SHx pins
- Adjustable deadtime through DT pin in QFN package
- Fixed Deadtime insertion of 200 ns in TSSOP package
- Supports 3.3-V, and 5-V logic inputs with 20-V abs max
- 4-ns typical propagation delay matching
- Compact QFN and TSSOP packages and footprints
- Efficient system design with [Power Blocks](#)
- Integrated protection features
  - BST undervoltage lockout (BSTUV)
  - GVDD undervoltage (GVDDUV)

## 2 Applications

- [E-Bikes, E-Scooters, and E-Mobility](#)
- [Cordless Garden and Power Tools, Lawnmowers](#)
- [Cordless Vacuum Cleaners](#)
- [Drones, Robotics, and RC Toys](#)
- [Industrial and Logistics Robots](#)
- [Power Tools](#)

## 3 Description

The DRV8770 device provides two half-bridge gate drivers, each capable of driving high-side and low-side N-channel power MOSFETs. The integrated bootstrap diode and external capacitor generate the correct gate drive voltages for the high-side MOSFETs while the GVDD drives the gates of the low-side MOSFETs. The gate drive architecture supports gate drive currents up to 750-mA source and 1.5-A sink.

The high voltage tolerance of the gate drive pins improves system robustness. The SHx phase pins can tolerate significant negative voltage transients, while the high-side gate driver supply can support higher positive voltage transients (115-V absolute maximum) on the BSTx and GHx pins. Small propagation delay and delay matching specifications minimize the dead-time requirement which further improves efficiency. Undervoltage protection is provided for both low and high side through GVDD and BST undervoltage lockout.

### Device Information<sup>(1)</sup>

PART NUMBER	PACKAGE	BODY SIZE (NOM)
DRV8770PW	TSSOP (20)	6.40 mm × 4.40 mm
DRV8770RGE	VQFN (24)	4.00 mm × 4.00 mm

- (1) For all available packages, see the orderable addendum at the end of the data sheet.

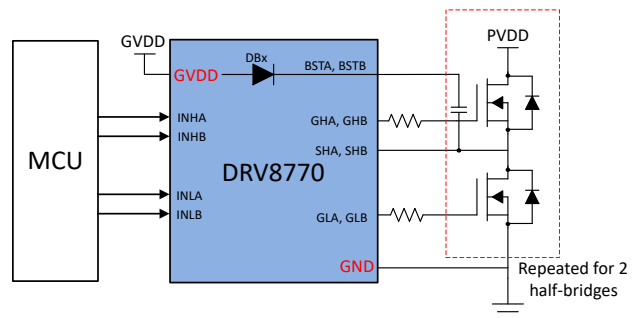

**Simplified Schematic for DRV8770**



## Table of Contents

<b>1 Features</b> .....	<b>1</b>	<b>8 Application and Implementation</b> .....	<b>14</b>
<b>2 Applications</b> .....	<b>1</b>	8.1 Application Information.....	14
<b>3 Description</b> .....	<b>1</b>	8.2 Typical Application.....	14
<b>4 Revision History</b> .....	<b>2</b>	<b>9 Power Supply Recommendations</b> .....	<b>17</b>
<b>5 Pin Configuration and Functions</b> .....	<b>3</b>	9.1 Bulk Capacitance Sizing.....	17
<b>6 Specifications</b> .....	<b>5</b>	<b>10 Layout</b> .....	<b>18</b>
6.1 Absolute Maximum Ratings .....	5	10.1 Layout Example.....	18
6.2 ESD Ratings Comm .....	5	10.2 Layout Guidelines.....	18
6.3 Recommended Operating Conditions .....	5	<b>11 Device and Documentation Support</b> .....	<b>19</b>
6.4 Thermal Information .....	6	11.1 Receiving Notification of Documentation Updates..	19
6.5 Electrical Characteristics .....	6	11.2 Support Resources.....	19
6.6 Typical Characteristics.....	8	11.3 Trademarks.....	19
<b>7 Detailed Description</b> .....	<b>9</b>	11.4 Electrostatic Discharge Caution.....	19
7.1 Overview.....	9	11.5 Glossary.....	19
7.2 Functional Block Diagram.....	9	<b>12 Mechanical, Packaging, and Orderable</b>	
7.3 Feature Description.....	9	<b>Information</b> .....	<b>19</b>
7.4 Device Functional Modes.....	13		

## 4 Revision History

NOTE: Page numbers for previous revisions may differ from page numbers in the current version.

DATE	REVISION	NOTES
July 2021	*	Initial Release

## 5 Pin Configuration and Functions

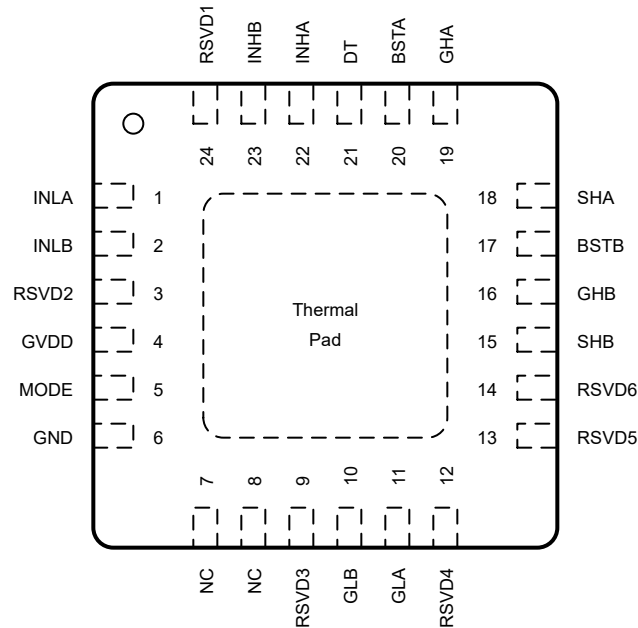

**Figure 5-1. DRV8770 RGE Package 24-Pin VQFN With Exposed Thermal Pad Top View**

**Table 5-1. Pin Functions—24-Pin DRV8770 Device**

PIN		TYPE <sup>(1)</sup>	DESCRIPTION
NAME	NO.		
BSTA	20	O	Bootstrap output pin. Connect capacitor between BSTA and SHA
BSTB	17	O	Bootstrap output pin. Connect capacitor between BSTB and SHB
DT	21	I	Deadtime input pin. Connect resistor to ground for variable deadtime, fixed deadtime when left it floating
GHA	19	O	High-side gate driver output. Connect to the gate of the high-side power MOSFET.
GHB	16	O	High-side gate driver output. Connect to the gate of the high-side power MOSFET.
GLA	11	O	Low-side gate driver output. Connect to the gate of the low-side power MOSFET.
GLB	10	O	Low-side gate driver output. Connect to the gate of the low-side power MOSFET.
GND	6	PWR	Device ground.
GVDD	4	PWR	Gate driver power supply input. Connect a X5R or X7R, GVDD-rated ceramic and greater then or equal to 10-uF local capacitance between the GVDD and GND pins.
INHA	22	I	High-side gate driver control input. This pin controls the output of the high-side gate driver.
INH B	23	I	High-side gate driver control input. This pin controls the output of the high-side gate driver.
INLA	1	I	Low-side gate driver control input. This pin controls the output of the low-side gate driver.
INLB	2	I	Low-side gate driver control input. This pin controls the output of the low-side gate driver.
MODE	5	I	Mode Input controls polarity of GLx compared to INLx inputs. Mode pin floating: GLx output polarity same(Non-Inverted) as INLx input Mode pin to GVDD: GLx output polarity inverted compared to INLx input
NC	7, 8	NC	No internal connection. This pin can be left floating or connected to system ground.
RSVD1, RSVD2, RSVD3, RSVD5, RSVD6	3, 9, 13, 14, 24	I	TI reserved pin. Leave pin floating.
RSVD4	12	I	TI reserved pin. Connect to GND
SHA	18	I	High-side source sense input. Connect to the high-side power MOSFET source.
SHB	15	I	High-side source sense input. Connect to the high-side power MOSFET source.

(1) PWR = power, I = input, O = output, NC = no connection

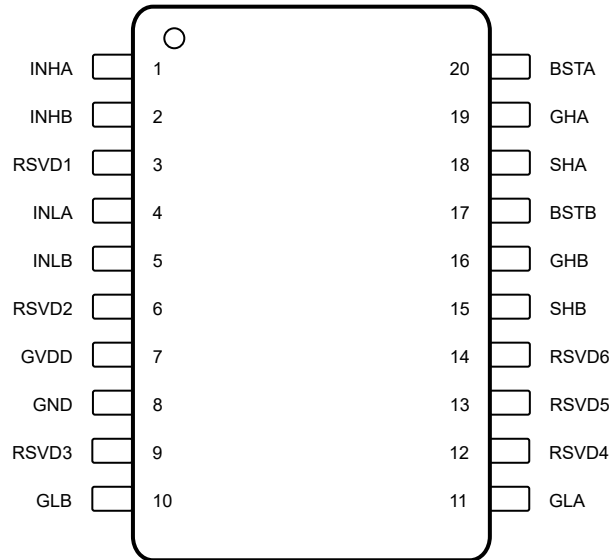

Figure 5-2. DRV8770 PW Package 20-Pin TSSOP Top View

Table 5-2. Pin Functions—20-Pin DRV8770 Device

PIN		TYPE <sup>(1)</sup>	DESCRIPTION
NAME	NO.		
BSTA	20	O	Bootstrap output pin. Connect capacitor between BSTA and SHA
BSTB	17	O	Bootstrap output pin. Connect capacitor between BSTB and SHB
GHA	19	O	High-side gate driver output. Connect to the gate of the high-side power MOSFET.
GHB	16	O	High-side gate driver output. Connect to the gate of the high-side power MOSFET.
GLA	11	O	Low-side gate driver output. Connect to the gate of the low-side power MOSFET.
GLB	10	O	Low-side gate driver output. Connect to the gate of the low-side power MOSFET.
GND	8	PWR	Device ground.
GVDD	7	PWR	Gate driver power supply input. Connect a X5R or X7R, GVDD-rated ceramic and greater then or equal to 10-uF local capacitance between the GVDD and GND pins.
INHA	1	I	High-side gate driver control input. This pin controls the output of the high-side gate driver.
INHB	2	I	High-side gate driver control input. This pin controls the output of the high-side gate driver.
INLA	4	I	Low-side gate driver control input. This pin controls the output of the low-side gate driver.
INLB	5	I	Low-side gate driver control input. This pin controls the output of the low-side gate driver.
RSVD1, RSVD2, RSVD3, RSVD5, RSVD6	3, 6, 9, 13, 14	I	TI reserved pin. Leave pin floating.
RSVD4	12	I	TI reserved pin. Connect to GND
SHA	18	I	High-side source sense input. Connect to the high-side power MOSFET source.
SHB	15	I	High-side source sense input. Connect to the high-side power MOSFET source.

(1) PWR = power, I = input, O = output, NC = no connection

## 6 Specifications

### 6.1 Absolute Maximum Ratings

over operating temperature range (unless otherwise noted)<sup>(1)</sup>

		MIN	MAX	UNIT
Gate driver regulator pin voltage	GVDD	-0.3	21.5	V
Bootstrap pin voltage	BSTx	-0.3	115	V
Bootstrap pin voltage	BSTx with respect to SHx	-0.3	21.5	V
Logic pin voltage	INHx, INLx, MODE, DT	-0.3	V <sub>GVDD</sub> +0.3	V
High-side gate drive pin voltage	GHx	-22	115	V
High-side gate drive pin voltage	GHx with respect to SHx	-0.3	22	V
Transient 500-ns high-side gate drive pin voltage	GHx with respect to SHx	-5	22	V
Low-side gate drive pin voltage	GLx	-0.3	V <sub>GVDD</sub> +0.3	V
Transient 500-ns low-side gate drive pin voltage	GLx	-5	V <sub>GVDD</sub> +0.3	V
High-side source pin voltage	SHx	-22	100	V
Ambient temperature, T <sub>A</sub>		-40	125	°C
Junction temperature, T <sub>J</sub>		-40	150	°C
Storage temperature, T <sub>stg</sub>		-65	150	°C

- (1) Stresses beyond those listed under *Absolute Maximum Rating* may cause permanent damage to the device. These are stress ratings only, which do not imply functional operation of the device at these or any other conditions beyond those indicated under *Recommended Operating Condition*. Exposure to absolute-maximum-rated conditions for extended periods may affect device reliability.

### 6.2 ESD Ratings Comm

		VALUE	UNIT
V <sub>(ESD)</sub>	Electrostatic discharge	Human body model (HBM), per ANSI/ESDA/JEDEC JS-001 <sup>(1)</sup>	±1000
		Charged device model (CDM), per JEDEC specification JESD22-C101 <sup>(2)</sup>	±250

- (1) JEDEC document JEP155 states that 500-V HBM allows safe manufacturing with a standard ESD control process.  
 (2) JEDEC document JEP157 states that 250-V CDM allows safe manufacturing with a standard ESD control process.

### 6.3 Recommended Operating Conditions

over operating temperature range (unless otherwise noted)

		MIN	NOM	MAX	UNIT
V <sub>GVDD</sub>	Power supply voltage	5		20	V
V <sub>SHx</sub>	High-side source pin voltage	-2		85	V
V <sub>SHx</sub>	Transient 2μs high-side source pin voltage	-22		85	V
V <sub>BST</sub>	Bootstrap pin voltage	5		105	V
V <sub>BST</sub>	Bootstrap pin voltage	5		20	V
V <sub>IN</sub>	Logic input voltage	0		V <sub>GVDD</sub>	V
f <sub>PWM</sub>	PWM frequency	0		200	kHz
V <sub>SHSL</sub>	Slew rate on SHx pin			2	V/ns
C <sub>BOOT</sub> <sup>(1)</sup>	Capacitor between BSTx and SHx			1	μF
T <sub>A</sub>	Operating ambient temperature	-40		125	°C
T <sub>J</sub>	Operating junction temperature	-40		150	°C

- (1) Current flowing through boot diode (D<sub>BOOT</sub>) needs to be limited for C<sub>BOOT</sub> > 1μF

## 6.4 Thermal Information

THERMAL METRIC <sup>(1)</sup>		DRV8770		UNIT
		PW (TSSOP)	RGE (VQFN)	
		20 PINS	24 PINS	
R <sub>θJA</sub>	Junction-to-ambient thermal resistance	97.4	49.3	°C/W
R <sub>θJC(top)</sub>	Junction-to-case (top) thermal resistance	38.3	42.5	°C/W
R <sub>θJB</sub>	Junction-to-board thermal resistance	48.8	26.5	°C/W
Ψ <sub>JT</sub>	Junction-to-top characterization parameter	4.3	2.2	°C/W
Ψ <sub>JB</sub>	Junction-to-board characterization parameter	48.4	26.4	°C/W
R <sub>θJC(bot)</sub>	Junction-to-case (bottom) thermal resistance	N/A	11.5	°C/W

(1) For more information about traditional and new thermal metrics, see the [Semiconductor and IC Package Thermal Metrics](#) application report.

## 6.5 Electrical Characteristics

4.8 V ≤ V<sub>GVDD</sub> ≤ 20 V, -40°C ≤ T<sub>J</sub> ≤ 150°C (unless otherwise noted)

PARAMETER		TEST CONDITIONS	MIN	TYP	MAX	UNIT
<b>POWER SUPPLIES (GVDD, BSTx)</b>						
I <sub>GVDD</sub>	GVDD standby mode current	INHx = INLx = 0; V <sub>BSTx</sub> = V <sub>GVDD</sub>	400	800	1400	μA
	GVDD active mode current	INHx = INLx = Switching @20kHz; V <sub>BSTx</sub> = V <sub>GVDD</sub> ; NO FETs connected	400	825	1400	μA
IL <sub>BSTx</sub>	Bootstrap pin leakage current	V <sub>BSTx</sub> = V <sub>SHx</sub> = 85V; V <sub>GVDD</sub> = 0V	2	4	7	μA
IL <sub>BS_TRAN</sub>	Bootstrap pin active mode transient leakage current	INHx = Switching@20kHz	30	105	220	μA
IL <sub>BS_DC</sub>	Bootstrap pin active mode leakage static current	INHx = High	30	85	150	μA
IL <sub>SHx</sub>	High-side source pin leakage current	INHx = INLx = 0; V <sub>BSTx</sub> - V <sub>SHx</sub> = 12V; V <sub>SHx</sub> = 0 to 85V	30	55	80	μA
<b>LOGIC-LEVEL INPUTS (INHx, INLx, MODE)</b>						
V <sub>IL_MODE</sub>	Input logic low voltage	Mode pin			0.6	V
V <sub>IL</sub>	Input logic low voltage	INLx, INHx pins			0.8	V
V <sub>IH_MODE</sub>	Input logic high voltage	Mode pin	3.7			V
V <sub>IH</sub>	Input logic high voltage	INLx, INHx pins	2.0			V
V <sub>HYS_MODE</sub>	Input hysteresis	Mode pin	1600	2000	2400	mV
V <sub>HYS</sub>	Input hysteresis	INLx, INHx pins	40	100	260	mV
I <sub>IL_INLx</sub>	INLx Input logic low current	V <sub>PIN</sub> (Pin Voltage) = 0 V; INLx in non-inverting mode	-1	0	1	μA
		V <sub>PIN</sub> (Pin Voltage) = 0 V; INLx in inverting mode	5	20	30	μA
I <sub>IH_INLx</sub>	INLx Input logic high current	V <sub>PIN</sub> (Pin Voltage) = 5 V; INLx in non-inverting mode	5	20	30	μA
		V <sub>PIN</sub> (Pin Voltage) = 5 V; INLx in inverting mode	0	0.5	1.5	μA
I <sub>IL</sub>	INHx, MODE Input logic low current	V <sub>PIN</sub> (Pin Voltage) = 0 V;	-1	0	1	μA
I <sub>IH</sub>	INHx, MODE Input logic high current	V <sub>PIN</sub> (Pin Voltage) = 5 V;	5	20	30	μA
R <sub>PD_INHx</sub>	INHx Input pulldown resistance	To GND	120	200	280	kΩ
R <sub>PD_INLx</sub>	INLx Input pulldown resistance	To GND, INLx in non-inverting mode	120	200	280	kΩ
R <sub>PU_INLx</sub>	INLx Input pullup resistance	To INT_5V, INLx in inverting mode	120	200	280	kΩ
R <sub>PD_MODE</sub>	MODE Input pulldown resistance	To GND	120	200	280	kΩ
<b>GATE DRIVERS (GHx, GLx, SHx, SLx)</b>						

$4.8\text{ V} \leq V_{\text{GVDD}} \leq 20\text{ V}$ ,  $-40^\circ\text{C} \leq T_{\text{J}} \leq 150^\circ\text{C}$  (unless otherwise noted)

PARAMETER		TEST CONDITIONS	MIN	TYP	MAX	UNIT
$V_{\text{GHx\_LO}}$	High-side gate drive low level voltage	$I_{\text{GLx}} = -100\text{ mA}$ ; $V_{\text{GVDD}} = 12\text{V}$ ; No FETs connected	0	0.15	0.35	V
$V_{\text{GHx\_HI}}$	High-side gate drive high level voltage ( $V_{\text{BSTx}} - V_{\text{GHx}}$ )	$I_{\text{GHx}} = 100\text{ mA}$ ; $V_{\text{GVDD}} = 12\text{V}$ ; No FETs connected	0.3	0.6	1.2	V
$V_{\text{GLx\_LO}}$	Low-side gate drive low level voltage	$I_{\text{GLx}} = -100\text{ mA}$ ; $V_{\text{GVDD}} = 12\text{V}$ ; No FETs connected	0	0.15	0.35	V
$V_{\text{GLx\_HI}}$	Low-side gate drive high level voltage ( $V_{\text{GVDD}} - V_{\text{GHx}}$ )	$I_{\text{GHx}} = 100\text{ mA}$ ; $V_{\text{GVDD}} = 12\text{V}$ ; No FETs connected	0.3	0.6	1.2	V
$I_{\text{DRIVEP\_HS}}$	High-side peak source gate current	$\text{GHx-SHx} = 12\text{V}$	400	750	1200	mA
$I_{\text{DRIVEN\_HS}}$	High-side peak sink gate current	$\text{GHx-SHx} = 0\text{V}$	850	1500	2100	mA
$I_{\text{DRIVEP\_LS}}$	Low-side peak source gate current	$\text{GLx} = 12\text{V}$	400	750	1200	mA
$I_{\text{DRIVEN\_LS}}$	Low-side peak sink gate current	$\text{GLx} = 0\text{V}$	850	1500	2100	mA
$t_{\text{PD}}$	Input to output propagation delay	$\text{INHx, INLx to GHx, GLx}$ ; $V_{\text{GVDD}} = V_{\text{BSTx}} - V_{\text{SHx}} > 8\text{V}$ ; $\text{SHx} = 0\text{V}$ , No load on GHx and GLx	70	125	180	ns
$t_{\text{PD\_match}}$	Matching propagation delay per phase	GHx turning OFF to GLx turning ON, GLx turning OFF to GHx turning ON; $V_{\text{GVDD}} = V_{\text{BSTx}} - V_{\text{SHx}} > 8\text{V}$ ; $\text{SHx} = 0\text{V}$ , No load on GHx and GLx	-30	$\pm 4$	30	ns
$t_{\text{PD\_match}}$	Matching propagation delay phase to phase	GHx/GLx turning ON to GHy/GLy turning ON, GHx/GLx turning OFF to GHy/GLy turning OFF; $V_{\text{GVDD}} = V_{\text{BSTx}} - V_{\text{SHx}} > 8\text{V}$ ; $\text{SHx} = 0\text{V}$ , No load on GHx and GLx	-30	$\pm 4$	30	ns
$t_{\text{R\_GLx}}$	GLx rise time (10% to 90%)	$C_{\text{LOAD}} = 1000\text{ pF}$ ; $V_{\text{GVDD}} = V_{\text{BSTx}} - V_{\text{SHx}} > 8\text{V}$ ; $\text{SHx} = 0\text{V}$	10	24	50	ns
$t_{\text{R\_GHx}}$	GHx rise time (10% to 90%)	$C_{\text{LOAD}} = 1000\text{ pF}$ ; $V_{\text{GVDD}} = V_{\text{BSTx}} - V_{\text{SHx}} > 8\text{V}$ ; $\text{SHx} = 0\text{V}$	10	24	50	ns
$t_{\text{F\_GLx}}$	GLx fall time (90% to 10%)	$C_{\text{LOAD}} = 1000\text{ pF}$ ; $V_{\text{GVDD}} = V_{\text{BSTx}} - V_{\text{SHx}} > 8\text{V}$ ; $\text{SHx} = 0\text{V}$	5	12	30	ns
$t_{\text{F\_GHx}}$	GHx fall time (90% to 10%)	$C_{\text{LOAD}} = 1000\text{ pF}$ ; $V_{\text{GVDD}} = V_{\text{BSTx}} - V_{\text{SHx}} > 8\text{V}$ ; $\text{SHx} = 0\text{V}$	5	12	30	ns
$t_{\text{DEAD}}$	Gate drive dead time	DT pin connected to GND	150	215	280	ns
		40 k $\Omega$ between DT pin and GND	150	200	260	ns
		400 k $\Omega$ between DT pin and GND	1500	2000	2600	ns
$t_{\text{PW\_MIN}}$	Minimum input pulse width on INHx, INLx that changes the output on GHx, GLx		40	70	150	ns
<b>BOOTSTRAP DIODES</b>						
$V_{\text{BOOTD}}$	Bootstrap diode forward voltage	$I_{\text{BOOT}} = 100\text{ }\mu\text{A}$	0.45	0.7	0.85	V
		$I_{\text{BOOT}} = 100\text{ mA}$	2	2.3	3.1	V
$R_{\text{BOOTD}}$	Bootstrap dynamic resistance ( $\Delta V_{\text{BOOTD}}/\Delta I_{\text{BOOT}}$ )	$I_{\text{BOOT}} = 100\text{ mA}$ and $80\text{ mA}$	11	15	25	$\Omega$
<b>PROTECTION CIRCUITS</b>						
$V_{\text{GVDDUV}}$	Gate Driver Supply undervoltage lockout (GVDDUV)	Supply rising	4.45	4.6	4.7	V
		Supply falling	4.2	4.35	4.4	V
$V_{\text{GVDDUV\_HYS}}$	Gate Driver Supply UV hysteresis	Rising to falling threshold	250	280	310	mV
$t_{\text{GVDDUV}}$	Gate Driver Supply undervoltage deglitch time		5	10	13	$\mu\text{s}$
$V_{\text{BSTUV}}$	Boot Strap undervoltage lockout ( $V_{\text{BSTx}} - V_{\text{SHx}}$ )	Supply rising	3.6	4.2	4.8	V
		Supply falling	3.5	4	4.5	V

$4.8\text{ V} \leq V_{\text{GVDD}} \leq 20\text{ V}$ ,  $-40^\circ\text{C} \leq T_J \leq 150^\circ\text{C}$  (unless otherwise noted)

PARAMETER		TEST CONDITIONS	MIN	TYP	MAX	UNIT
$V_{\text{BSTUV\_HYS}}$	Bootstrap UV hysteresis	Rising to falling threshold		200		mV
$t_{\text{BSTUV}}$	Bootstrap undervoltage deglitch time		6	10	22	$\mu\text{s}$

## 6.6 Typical Characteristics

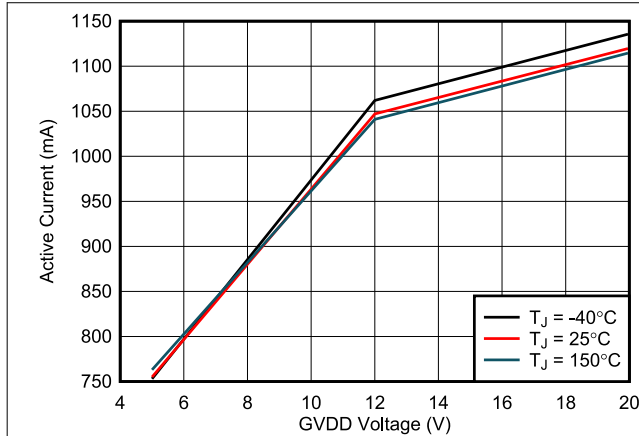

Figure 6-1. Supply Current Over GVDD Voltage

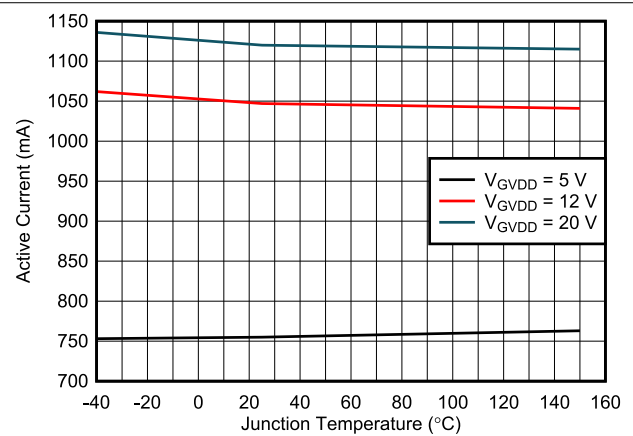

Figure 6-2. Supply Current Over Temperature

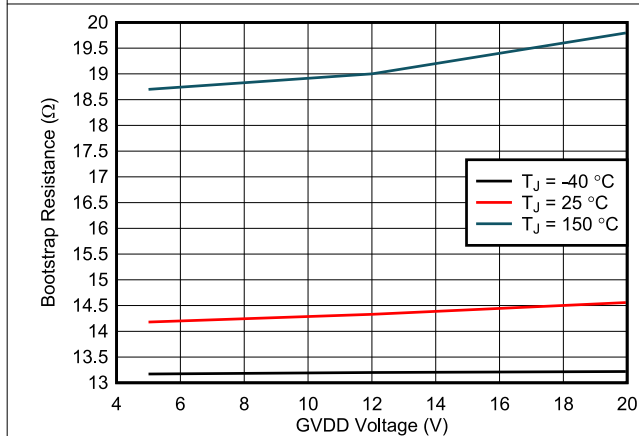

Figure 6-3. Bootstrap Resistance Over GVDD Voltage

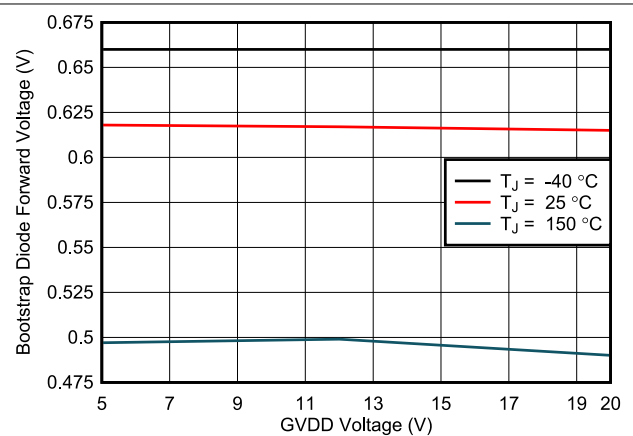

Figure 6-4. Bootstrap Diode Forward Voltage over GVDD Voltage



half-bridge gate drivers can be used in combination to drive a brushed DC motor or separately to drive other types of loads.

### 7.3.1.1 Gate Drive Timings

#### 7.3.1.1.1 Propagation Delay

The propagation delay time ( $t_{pd}$ ) is measured as the time between an input logic edge to a detected output change. This time has two parts consisting of the input deglitcher delay and the delay through the analog gate drivers.

The input deglitcher prevents high-frequency noise on the input pins from affecting the output state of the gate drivers. The analog gate drivers have a small delay that contributes to the overall propagation delay of the device.

#### 7.3.1.1.2 Deadtime and Cross-Conduction Prevention

In the DRV8770, high- and low-side inputs operate independently, with an exception to prevent cross conduction when high and low side are turned ON at same time. The DRV8770 turns OFF high- and low- side output to prevent shoot through when high- and low-side inputs are logic high at same time.

The DRV8770 also provides deadtime insertion to prevents both external MOSFETs of each power-stage from switching on at the same time. In devices with DT pin (QFN package device), deadtime can be linearly adjusted between 200 ns to 2000 ns by connecting resistor between DT and ground. When DT pin is connected to ground, fixed deadtime of 200 ns (typical value) is inserted. The value of resistor can be calculated using [Equation 1](#).

$$R_{DT}(k\Omega) = \frac{\text{Deadtime (ns)}}{5} \tag{1}$$

In device without DT pin (TSSOP package device), fixed deadtime of 200 ns (Typical value) is inserted to prevent high and low side gate output turning on at same time.

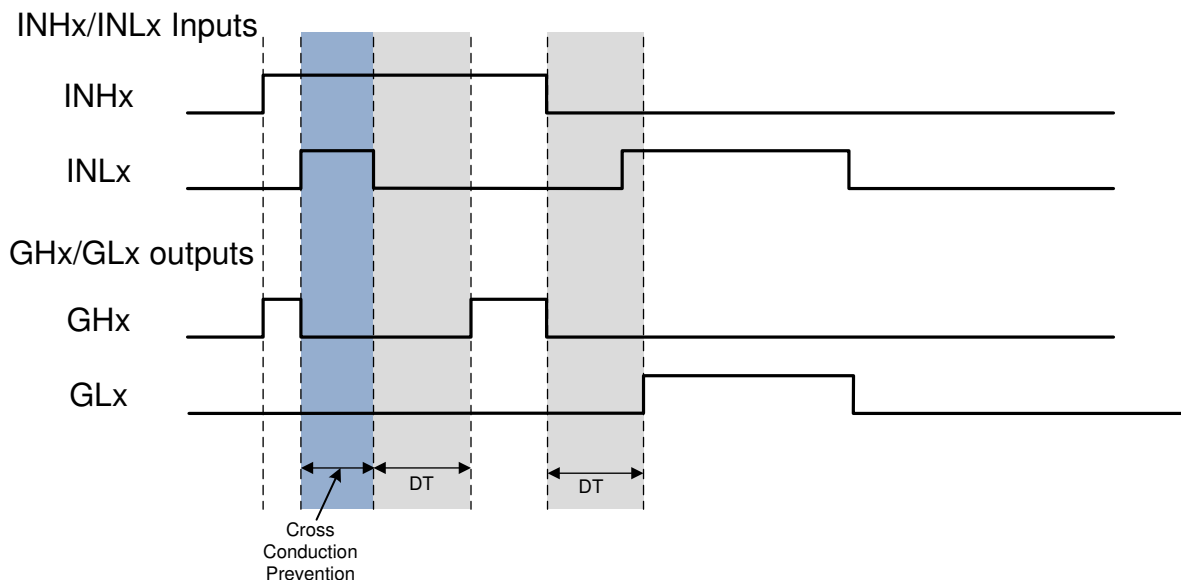
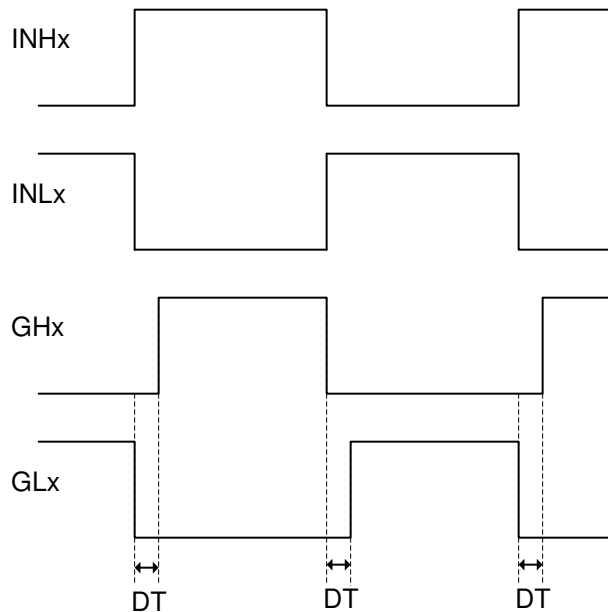

**Figure 7-2. Cross Conduction Prevention and Deadtime Insertion**

#### 7.3.1.2 Mode (Inverting and non-inverting INLx)

The DRV8770 has flexibility of accepting different kind of inputs on INLx. In the QFN (RGE) package variant, the MODE pin provides option of GLx output inverted or non-inverted compared to polarity of signal on INLx pin.

When the MODE pin is left floating, INLx is configured to be in non-inverting mode and GLx output is in phase with INLx (see Figure 7-3). When MODE pin is connected to GVDD, GLx output is out of phase with inputs (see Figure 7-4). The TSSOP (PW) package variant does not have a MODE pin, so the INLx pins are inverted by default.



**Figure 7-3. Non-Inverted INLx inputs (MODE = floating)**

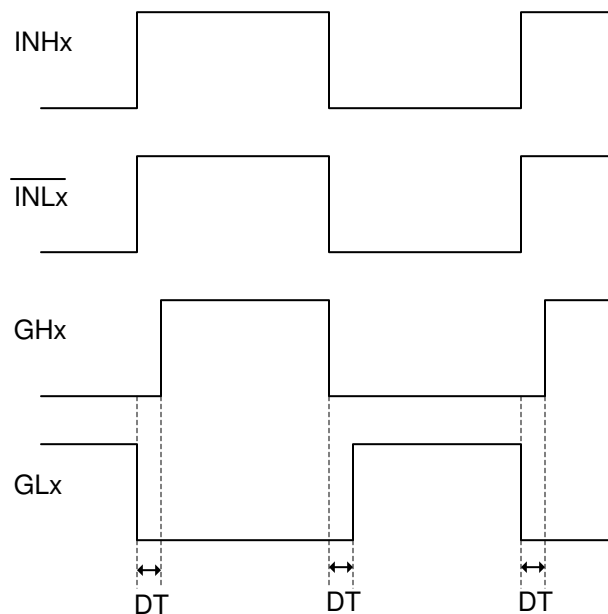

**Figure 7-4. Inverted INLx inputs (MODE = GVDD or TSSOP package variant)**

Table 7-1 shows the states of the gate drivers and FET half bridge when MODE = floating.

**Table 7-1. Logic table when MODE = floating**

INHx	INLx	GHx	GLx	Half Bridge State
0	0	L	L	Z, FETs disabled
0	1	L	H	L, low-side FET enabled
1	0	H	L	H, high-side FET enabled

**Table 7-1. Logic table when MODE = floating (continued)**

INHx	INLx	GHx	GLx	Half Bridge State
1	1	L	L	Z, invalid state

Table 7-2 shows the states of the gate drivers and FET half bridge for the inverted mode (MODE = GVDD or the default mode of the TSSOP package). In this mode, the INHx and INLx pins can be tied together to reduce the number of control signals from a microcontroller, as shown in Table 7-3. In this configuration, the device controls the deadtime as described in Section 7.3.1.1.2.

**Table 7-2. Logic table when MODE = GVDD or TSSOP package variant**

INHx	INLx	GHx	GLx	Half Bridge State
0	0	L	H	L, low-side FET enabled
0	1	L	L	Z, FETs disabled
1	0	L	L	Z, invalid state
1	1	H	L	H, high-side FET enabled

**Table 7-3. Logic table when INHx = INLx for MODE = GVDD or TSSOP package variant**

INHx = INLx	GHx	GLx	Half Bridge State
0	L	H	L, low-side FET enabled
1	H	L	H, high-side FET enabled

### 7.3.2 Pin Diagrams

Figure 7-5 shows the input structure for the logic level pins INHx, INLx. INHx and INLx has passive pull down, so when inputs are floating the output of gate driver will be pulled low. Figure 7-6 shows the input structure for the logic level pin inverted INLx. INLx in inverted mode has passive pull up, so when inputs are floating the output of gate driver will be pulled low.

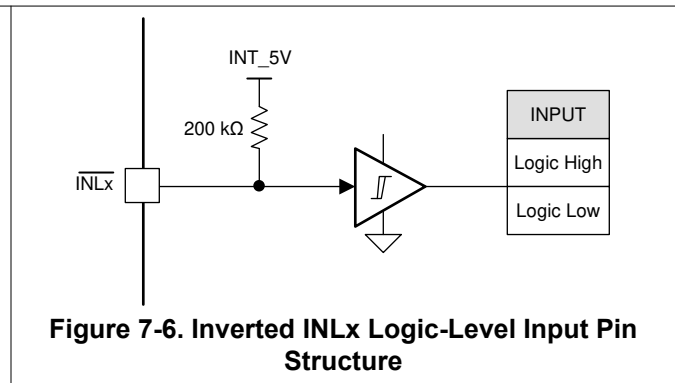
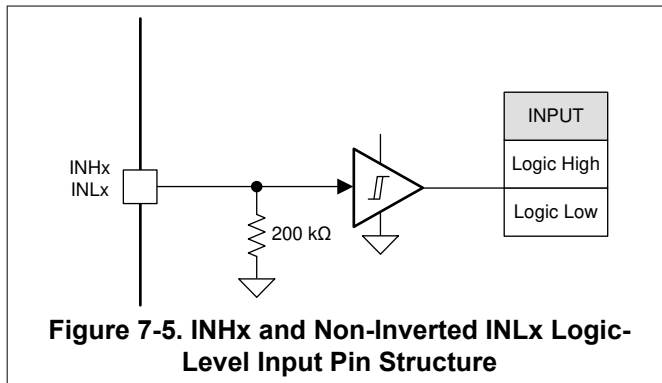

### 7.3.3 Gate Driver Protective Circuits

The DRV8770 is protected against BSTx undervoltage and GVDD undervoltage events.

**Table 7-4. Fault Action and Response**

FAULT	CONDITION	GATE DRIVER	RECOVERY
V <sub>BSTx</sub> undervoltage (BSTUV)	V <sub>BSTx</sub> < V <sub>BSTUV</sub>	GHx - Hi-Z	Automatic: V <sub>BSTx</sub> > V <sub>BSTUV</sub> and low to high PWM edge detected on INHx pin
GVDD undervoltage (GVDDUV)	V <sub>GVDD</sub> < V <sub>GVDDUV</sub>	Hi-Z	Automatic: V <sub>GVDD</sub> > V <sub>GVDDUV</sub>

### **7.3.3.1 $V_{BSTx}$ Undervoltage Lockout (BSTUV)**

The DRV8770 has separate voltage comparator to detect undervoltage condition for each phase. If at any time the supply voltage on the BSTx pin falls lower than the VBSTUV threshold, high side external MOSFETs of that particular phase is disabled by disabling (Hi-Z) GHx pin. Normal operation starts again when the BSTUV condition clears and low to high PWM edge is detected on INHx input on the same phase BSTUV was detected. BSTUV protection ensures that high side gate driver are not switched when BSTx pin has lower value.

### **7.3.3.2 GVDD Undervoltage Lockout (GVDDUV)**

If at any time the voltage on the GVDD pin falls lower than the  $V_{GVDDUV}$  threshold voltage, all of the external MOSFETs are disabled. Normal operation starts again GVDDUV condition clears. GVDDUV protection ensures that gate driver are not switched when GVDD input is at lower value.

## **7.4 Device Functional Modes**

Whenever the  $GVDD > V_{GVDDUV}$  and  $V_{BSTx} > V_{BSTUV}$  the device is in operating (active) mode, in this condition gate driver output GHx and GLx will follow respective inputs INHx and INLx.



## 8.2.1 Design Requirements

Table 8-1 lists the example design input parameters for system design.

**Table 8-1. Design Parameters**

EXAMPLE DESIGN PARAMETER	REFERENCE	EXAMPLE VALUE
MOSFET	-	CSD19532Q5B
Gate Supply Voltage	V <sub>GVDD</sub>	12 V
Gate Charge	Q <sub>G</sub>	48 nC

## 8.2.2 Detailed Design Procedure

### Bootstrap Capacitor and GVDD Capacitor Selection

The bootstrap capacitor must be sized to maintain the bootstrap voltage above the undervoltage lockout for normal operation. Equation 2 calculates the maximum allowable voltage drop across the bootstrap capacitor:

$$\Delta V_{BSTX} = V_{GVDD} - V_{BOOTD} - V_{BSTUV} \quad (2)$$

$$= 12 \text{ V} - 0.85 \text{ V} - 4.5 \text{ V} = 6.65 \text{ V}$$

where

- V<sub>GVDD</sub> is the supply voltage of the gate drive
- V<sub>BOOTD</sub> is the forward voltage drop of the bootstrap diode
- V<sub>BSTUV</sub> is the threshold of the bootstrap undervoltage lockout

In this example the allowed voltage drop across bootstrap capacitor is 6.65 V. It is generally recommended that ripple voltage on both the bootstrap capacitor and GVDD capacitor should be minimized as much as possible. Many of commercial, industrial, and automotive applications use ripple value between 0.5 V to 1 V.

The total charge needed per switching cycle can be estimated with Equation 3:

$$Q_{TOT} = Q_G + \frac{I_{LBS\_TRANS}}{f_{SW}} \quad (3)$$

$$= 48 \text{ nC} + 220 \text{ } \mu\text{A} / 20 \text{ kHz} = 50 \text{ nC} + 11 \text{ nC} = 59 \text{ nC}$$

where

- Q<sub>G</sub> is the total MOSFET gate charge
- I<sub>LBS\_TRAN</sub> is the bootstrap pin leakage current
- f<sub>SW</sub> is the is the PWM frequency

The minimum bootstrap capacitor can then be estimated as below assuming 1-V ΔV<sub>BSTX</sub>:

$$C_{BST\_MIN} = Q_{TOT} / \Delta V_{BSTX} \quad (4)$$

$$= 59 \text{ nC} / 1 \text{ V} = 59 \text{ nF}$$

The calculated value of minimum bootstrap capacitor is 59 nF. It should be noted that, this value of capacitance is needed at full bias voltage. In practice, the value of the bootstrap capacitor must be greater than calculated value to allow for situations where the power stage may skip pulse due to various transient conditions. It is recommended to use a 100 nF bootstrap capacitor in this example. It is also recommended to include enough margin and place the bootstrap capacitor as close to the BSTx and SHx pins as possible.

**Note**

If the bootstrap capacitor value ( $C_{BSTx}$ ) is above 1  $\mu\text{F}$ , then current flowing through internal bootstrap diode needs to be limited.

The local GVDD bypass capacitor must be greater than the value of bootstrap capacitor value (generally 10 times the bootstrap capacitor value).

$$C_{GVDD} \geq 10 \times C_{BSTX} \tag{5}$$

$$= 10 \times 100 \text{ nF} = 1 \mu\text{F}$$

For this example application, choose 1- $\mu\text{F}$   $C_{GVDD}$  capacitor. Choose a capacitor with a voltage rating at least twice the maximum voltage that it will be exposed to because most ceramic capacitors lose significant capacitance when biased. This value also improves the long term reliability of the system.

**Gate Resistance Selection**

The slew rate of the SHx connection will be dependent on the rate at which the gate of the external MOSFETs is controlled. The pull-up/pull-down strength of the DRV8770 is fixed internally, hence slew rate of gate voltage can be controlled with an external series gate resistor. In some applications the gate charge, which is load on gate driver device, is significantly larger than gate driver peak output current capability. In such applications external gate resistors can limit the peak output current of the gate driver. External gate resistors are also used to damp ringing and noise.

The specific parameters of the MOSFET, system voltage, and board parasitics will all affect the final slew rate, so generally selecting an optimal value or configuration of external gate resistor is an iterative process.

**8.2.3 Application Curves**

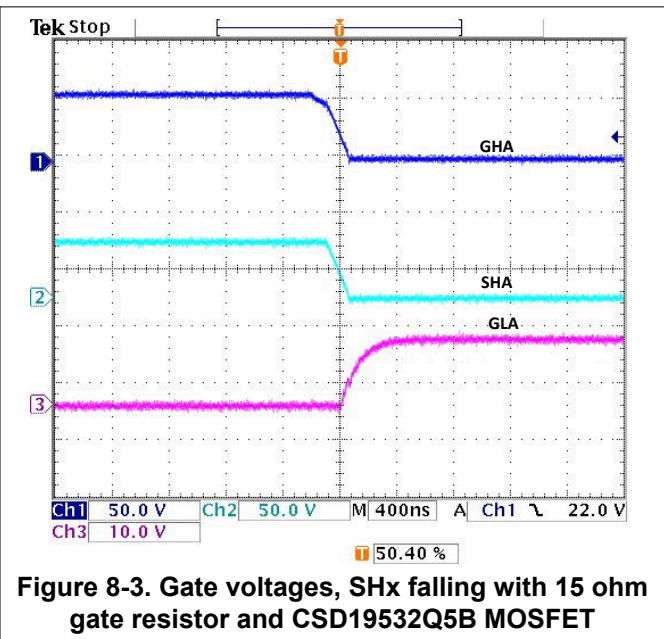
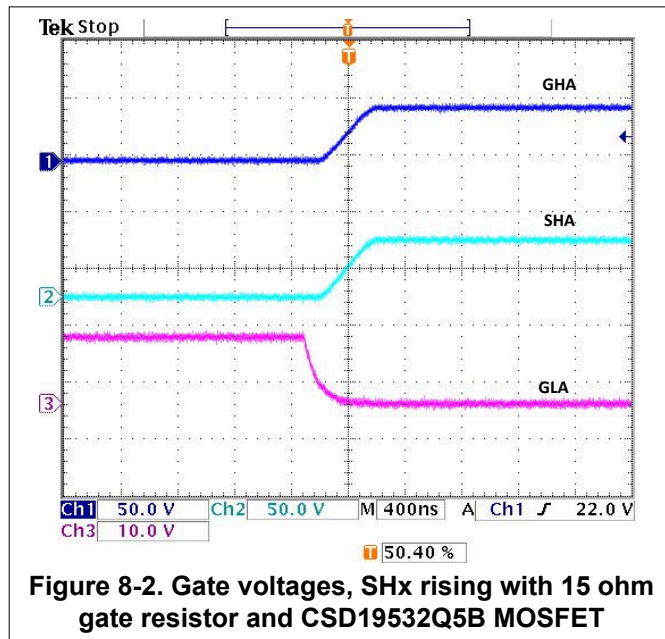

## 9 Power Supply Recommendations

The DRV8770 is designed to operate from an input voltage supply (GVDD) range from 4.8 V to 20 V. A local bypass capacitor should be placed between the GVDD and GND pins. This capacitor should be located as close to the device as possible. A low ESR, ceramic surface mount capacitor is recommended. It is recommended to use two capacitors across GVDD and GND: a low capacitance ceramic surface-mount capacitor for high frequency filtering placed very close to GVDD and GND pin, and another high capacitance value surface-mount capacitor for device bias requirements. In a similar manner, the current pulses delivered by the GHx pins are sourced from the BSTx pins. Therefore, capacitor across the BSTx to SHx is recommended, it should be high enough capacitance value capacitor to deliver GHx pulses.

### 9.1 Bulk Capacitance Sizing

Having appropriate local bulk capacitance is an important factor in motor drive system design. It is generally beneficial to have more bulk capacitance, while the disadvantages are increased cost and physical size. The amount of local capacitance depends on a variety of factors including:

- The highest current required by the motor system
- The power supply's type, capacitance, and ability to source current
- The amount of parasitic inductance between the power supply and motor system
- The acceptable supply voltage ripple
- Type of motor (brushed DC, brushless DC, stepper)
- The motor startup and braking methods

The inductance between the power supply and motor drive system will limit the rate current can change from the power supply. If the local bulk capacitance is too small, the system will respond to excessive current demands or dumps from the motor with a change in voltage. When adequate bulk capacitance is used, the motor voltage remains stable and high current can be quickly supplied.

The data sheet provides a recommended minimum value, but system level testing is required to determine the appropriate sized bulk capacitor.

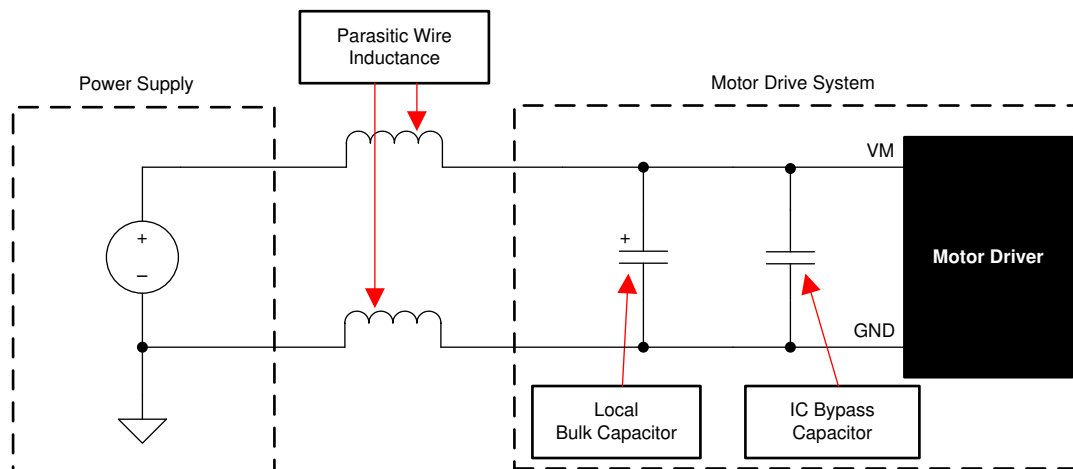

**Figure 9-1. Motor Drive Supply Parasitics Example**

## 10 Layout

### 10.1 Layout Example

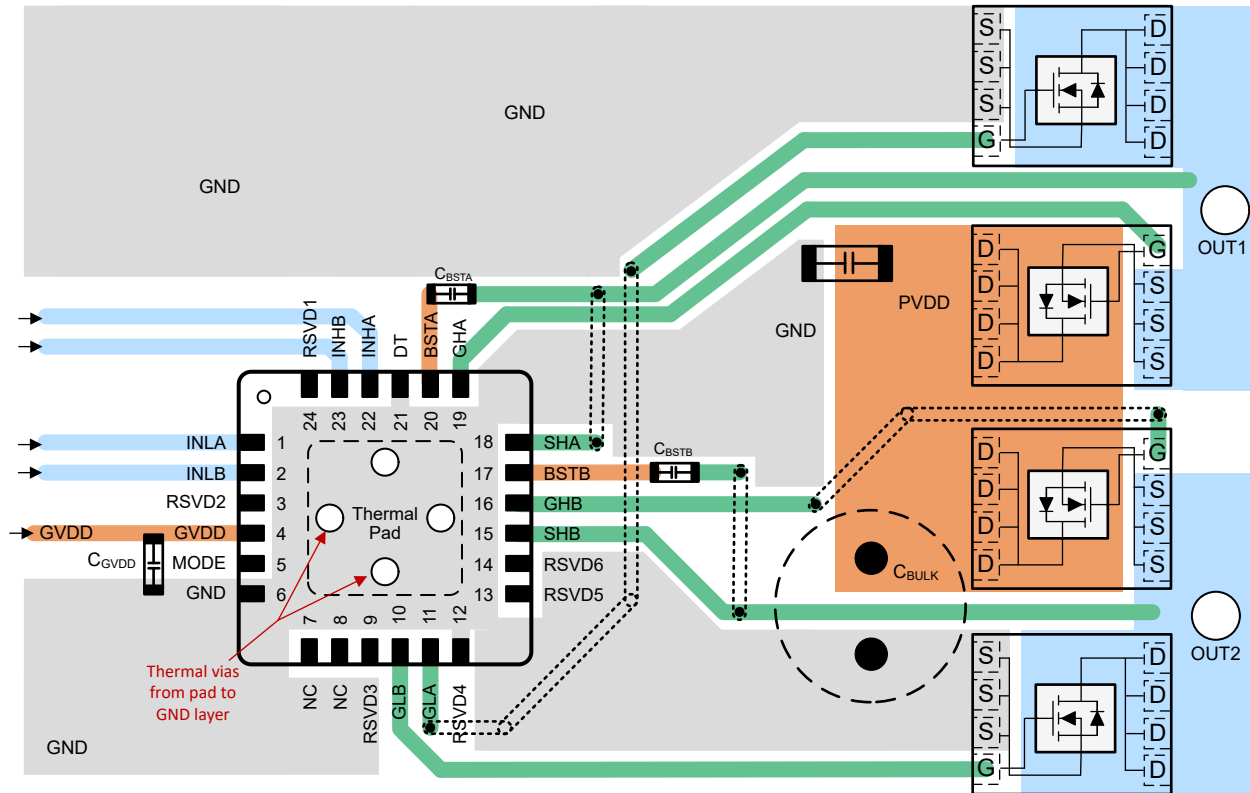

### 10.2 Layout Guidelines

- Low ESR/ESL capacitors must be connected close to the device between GVDD and GND and between BSTx and SHx pins to support high peak currents drawn from GVDD and BSTx pins during the turn-on of the external MOSFETs.
- To prevent large voltage transients at the drain of the top MOSFET, a low ESR electrolytic capacitor and a good quality ceramic capacitor must be connected between the high side MOSFET drain and ground.
- In order to avoid large negative transients on the switch node (SHx) pin, the parasitic inductances between the source of the high-side MOSFET and the source of the low-side MOSFET must be minimized.
- In order to avoid unexpected transients, the parasitic inductance of the GHx, SHx, and GLx connections must be minimized. Minimize the trace length and number of vias wherever possible. Minimum 10 mil and typical 15 mil trace width is recommended.
- Resistance between DT and GND must be placed as close as possible to device
- Place the gate driver as close to the MOSFETs as possible. Confine the high peak currents that charge and discharge the MOSFET gates to a minimal physical area by reducing trace length. This confinement decreases the loop inductance and minimize noise issues on the gate terminals of the MOSFETs.
- In QFN package device variants, NC pins can be connected to GND to increase ground connection between thermal pad and external ground plane.
- Refer to sections *General Routing Techniques and MOSFET Placement and Power Stage Routing* in [Application Report](#)

## 11 Device and Documentation Support

### 11.1 Receiving Notification of Documentation Updates

To receive notification of documentation updates, navigate to the device product folder on ti.com. In the upper right corner, click on *Alert me* to register and receive a weekly digest of any product information that has changed. For change details, review the revision history included in any revised document.

### 11.2 Support Resources

[TI E2E™ support forums](#) are an engineer's go-to source for fast, verified answers and design help — straight from the experts. Search existing answers or ask your own question to get the quick design help you need.

Linked content is provided "AS IS" by the respective contributors. They do not constitute TI specifications and do not necessarily reflect TI's views; see TI's [Terms of Use](#).

### 11.3 Trademarks

TI E2E™ is a trademark of Texas Instruments.  
All trademarks are the property of their respective owners.

### 11.4 Electrostatic Discharge Caution



This integrated circuit can be damaged by ESD. Texas Instruments recommends that all integrated circuits be handled with appropriate precautions. Failure to observe proper handling and installation procedures can cause damage.

ESD damage can range from subtle performance degradation to complete device failure. Precision integrated circuits may be more susceptible to damage because very small parametric changes could cause the device not to meet its published specifications.

### 11.5 Glossary

[TI Glossary](#) This glossary lists and explains terms, acronyms, and definitions.

## 12 Mechanical, Packaging, and Orderable Information

The following pages include mechanical, packaging, and orderable information. This information is the most current data available for the designated devices. This data is subject to change without notice and revision of this document. For browser-based versions of this data sheet, refer to the left-hand navigation.

**PACKAGING INFORMATION**

Orderable Device	Status (1)	Package Type	Package Drawing	Pins	Package Qty	Eco Plan (2)	Lead finish/ Ball material (6)	MSL Peak Temp (3)	Op Temp (°C)	Device Marking (4/5)	Samples
DRV8770RGER	ACTIVE	VQFN	RGE	24	3000	RoHS & Green	NIPDAU	Level-1-260C-UNLIM	-40 to 125	8770	Samples

(1) The marketing status values are defined as follows:

**ACTIVE:** Product device recommended for new designs.

**LIFEBUY:** TI has announced that the device will be discontinued, and a lifetime-buy period is in effect.

**NRND:** Not recommended for new designs. Device is in production to support existing customers, but TI does not recommend using this part in a new design.

**PREVIEW:** Device has been announced but is not in production. Samples may or may not be available.

**OBSOLETE:** TI has discontinued the production of the device.

(2) **RoHS:** TI defines "RoHS" to mean semiconductor products that are compliant with the current EU RoHS requirements for all 10 RoHS substances, including the requirement that RoHS substance do not exceed 0.1% by weight in homogeneous materials. Where designed to be soldered at high temperatures, "RoHS" products are suitable for use in specified lead-free processes. TI may reference these types of products as "Pb-Free".

**RoHS Exempt:** TI defines "RoHS Exempt" to mean products that contain lead but are compliant with EU RoHS pursuant to a specific EU RoHS exemption.

**Green:** TI defines "Green" to mean the content of Chlorine (Cl) and Bromine (Br) based flame retardants meet JS709B low halogen requirements of <=1000ppm threshold. Antimony trioxide based flame retardants must also meet the <=1000ppm threshold requirement.

(3) MSL, Peak Temp. - The Moisture Sensitivity Level rating according to the JEDEC industry standard classifications, and peak solder temperature.

(4) There may be additional marking, which relates to the logo, the lot trace code information, or the environmental category on the device.

(5) Multiple Device Markings will be inside parentheses. Only one Device Marking contained in parentheses and separated by a "~" will appear on a device. If a line is indented then it is a continuation of the previous line and the two combined represent the entire Device Marking for that device.

(6) Lead finish/Ball material - Orderable Devices may have multiple material finish options. Finish options are separated by a vertical ruled line. Lead finish/Ball material values may wrap to two lines if the finish value exceeds the maximum column width.

**Important Information and Disclaimer:** The information provided on this page represents TI's knowledge and belief as of the date that it is provided. TI bases its knowledge and belief on information provided by third parties, and makes no representation or warranty as to the accuracy of such information. Efforts are underway to better integrate information from third parties. TI has taken and continues to take reasonable steps to provide representative and accurate information but may not have conducted destructive testing or chemical analysis on incoming materials and chemicals. TI and TI suppliers consider certain information to be proprietary, and thus CAS numbers and other limited information may not be available for release.

In no event shall TI's liability arising out of such information exceed the total purchase price of the TI part(s) at issue in this document sold by TI to Customer on an annual basis.

**TAPE AND REEL INFORMATION**

**QUADRANT ASSIGNMENTS FOR PIN 1 ORIENTATION IN TAPE**

\*All dimensions are nominal

Device	Package Type	Package Drawing	Pins	SPQ	Reel Diameter (mm)	Reel Width W1 (mm)	A0 (mm)	B0 (mm)	K0 (mm)	P1 (mm)	W (mm)	Pin1 Quadrant
DRV8770RGER	VQFN	RGE	24	3000	330.0	12.4	4.25	4.25	1.15	8.0	12.0	Q2

**TAPE AND REEL BOX DIMENSIONS**

\*All dimensions are nominal

Device	Package Type	Package Drawing	Pins	SPQ	Length (mm)	Width (mm)	Height (mm)
DRV8770RGER	VQFN	RGE	24	3000	367.0	367.0	35.0

**RGE 24**

**GENERIC PACKAGE VIEW**

**VQFN - 1 mm max height**

PLASTIC QUAD FLATPACK - NO LEAD

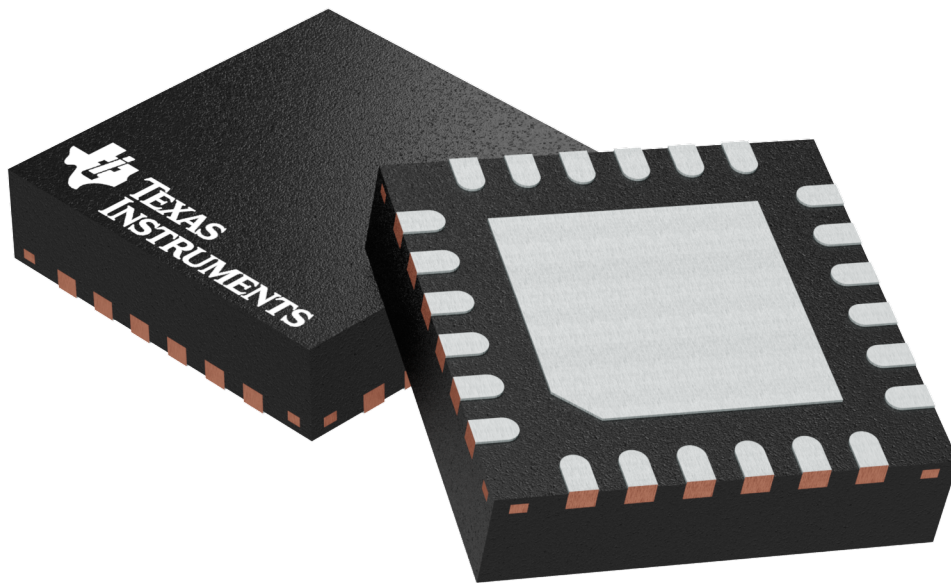

Images above are just a representation of the package family, actual package may vary.  
Refer to the product data sheet for package details.

4204104/H

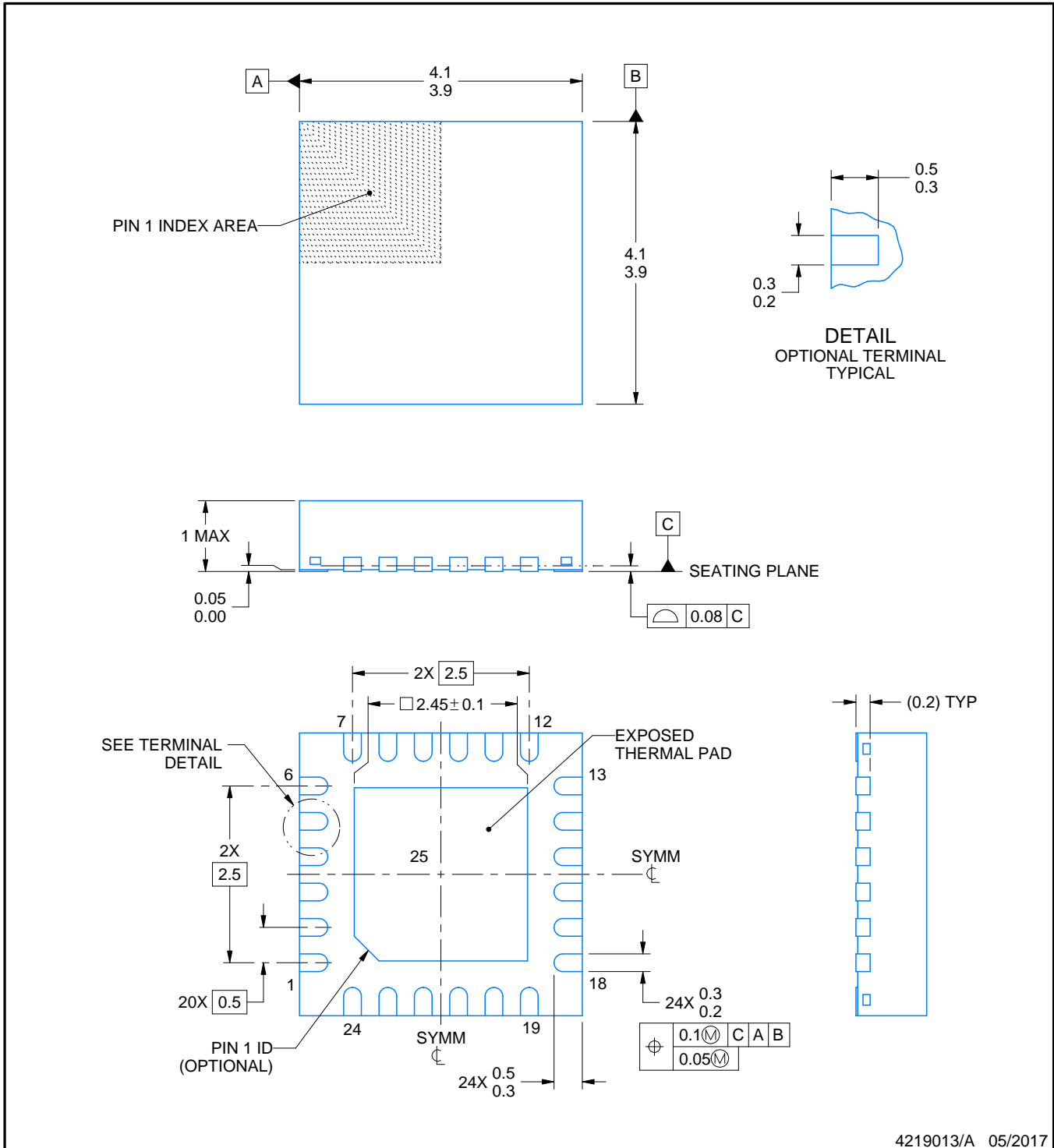
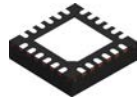

4219013/A 05/2017

NOTES:

1. All linear dimensions are in millimeters. Any dimensions in parenthesis are for reference only. Dimensioning and tolerancing per ASME Y14.5M.
2. This drawing is subject to change without notice.
3. The package thermal pad must be soldered to the printed circuit board for thermal and mechanical performance.



# EXAMPLE STENCIL DESIGN

RGE0024B

VQFN - 1 mm max height

PLASTIC QUAD FLATPACK - NO LEAD

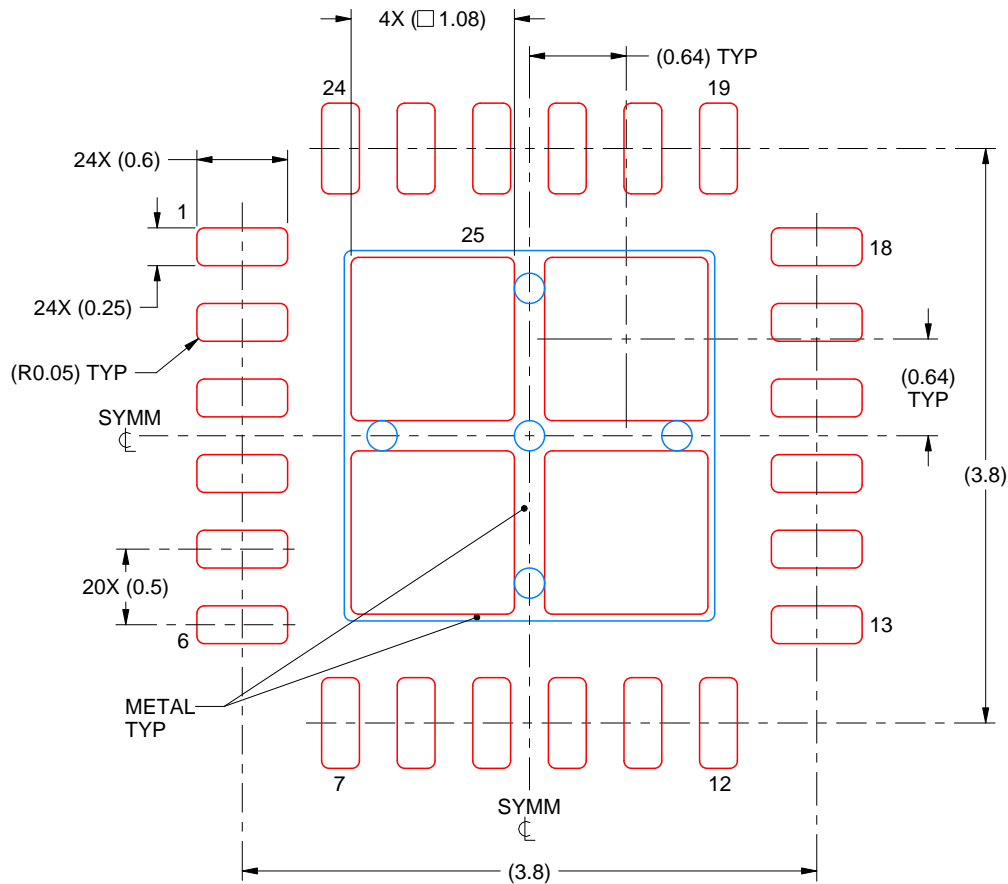

**SOLDER PASTE EXAMPLE**  
 BASED ON 0.125 mm THICK STENCIL

EXPOSED PAD 25  
 78% PRINTED SOLDER COVERAGE BY AREA UNDER PACKAGE  
 SCALE:20X

4219013/A 05/2017

NOTES: (continued)

6. Laser cutting apertures with trapezoidal walls and rounded corners may offer better paste release. IPC-7525 may have alternate design recommendations.

## IMPORTANT NOTICE AND DISCLAIMER

TI PROVIDES TECHNICAL AND RELIABILITY DATA (INCLUDING DATA SHEETS), DESIGN RESOURCES (INCLUDING REFERENCE DESIGNS), APPLICATION OR OTHER DESIGN ADVICE, WEB TOOLS, SAFETY INFORMATION, AND OTHER RESOURCES "AS IS" AND WITH ALL FAULTS, AND DISCLAIMS ALL WARRANTIES, EXPRESS AND IMPLIED, INCLUDING WITHOUT LIMITATION ANY IMPLIED WARRANTIES OF MERCHANTABILITY, FITNESS FOR A PARTICULAR PURPOSE OR NON-INFRINGEMENT OF THIRD PARTY INTELLECTUAL PROPERTY RIGHTS.

These resources are intended for skilled developers designing with TI products. You are solely responsible for (1) selecting the appropriate TI products for your application, (2) designing, validating and testing your application, and (3) ensuring your application meets applicable standards, and any other safety, security, regulatory or other requirements.

These resources are subject to change without notice. TI grants you permission to use these resources only for development of an application that uses the TI products described in the resource. Other reproduction and display of these resources is prohibited. No license is granted to any other TI intellectual property right or to any third party intellectual property right. TI disclaims responsibility for, and you will fully indemnify TI and its representatives against, any claims, damages, costs, losses, and liabilities arising out of your use of these resources.

TI's products are provided subject to [TI's Terms of Sale](#) or other applicable terms available either on [ti.com](https://www.ti.com) or provided in conjunction with such TI products. TI's provision of these resources does not expand or otherwise alter TI's applicable warranties or warranty disclaimers for TI products.

TI objects to and rejects any additional or different terms you may have proposed.

Mailing Address: Texas Instruments, Post Office Box 655303, Dallas, Texas 75265  
Copyright © 2023, Texas Instruments Incorporated

## Looking for pricing, stock, or lifecycle information?

Click below to explore more details on WIN SOURCE:

 [View DRV8770RGER on WIN SOURCE](#)

 [Texas Instruments](#) Information

## Optimize Your Supply Chain with WIN SOURCE Solutions

-  Global Sourcing Solution
-  Obsolete Management
-  Cost Control Management
-  Shortage Management
-  Alternative Solution
-  Excess Inventory Management