

DIGITAL I²C HUMIDITY AND TEMPERATURE SENSOR

Features

- Relative Humidity Sensor
 - ± 4.5% RH (maximum @ 0–80% RH)
- Temperature Sensor
 - ±0.5 °C accuracy (typical)
 - ±1 °C accuracy (maximum @ 0 to 70 °C)
- 0 to 100% RH operating range
- –40 to +85 °C (GM) or 0 to +70 °C operating range (FM)
- Wide operating voltage range (2.1 to 3.6 V)
- Low Power Consumption
 - 240 µA during RH conversion
- I²C host interface
- Integrated on-chip heater
- 4x4 mm QFN package
- Excellent long term stability
- Factory calibrated
- Optional factory-installed cover
 - Low-profile
 - Protection during reflow
 - Excludes liquids and particulates (hydrophobic/oleophobic)



Patent protected; patents pending

Applications

- Industrial HVAC/R
- Thermostats/humidistats
- Respiratory therapy
- White goods
- Micro-environments/data centers
- Automotive climate control and de-fogging
- Asset and goods tracking

Description

The Si7005 is a digital relative humidity and temperature sensor. This monolithic CMOS IC integrates temperature and humidity sensor elements, an analog-to-digital converter, signal processing, calibration data, and an I²C host interface. The patented use of industry-standard, low-K polymeric dielectrics for sensing humidity enables the construction of a low-power, monolithic CMOS sensor IC with low drift and hysteresis and excellent long term stability.

Both the temperature and humidity sensors are factory-calibrated and the calibration data is stored in the on-chip non-volatile memory. This ensures that the sensors are fully interchangeable, with no recalibration or software changes required.

The Si7005 is packaged in a 4x4 mm QFN package and is reflow solderable. The optional factory-installed protective cover offers a low-profile, convenient means of protecting the sensor during assembly (e.g., reflow soldering) and throughout the life of the product, excluding liquids (hydrophobic/oleophobic) and particulates.

The Si7005 offers an accurate, low-power, factory-calibrated digital solution ideal for measuring temperature, humidity, and dew-point in applications ranging from HVAC/R and asset tracking to industrial and consumer platforms.

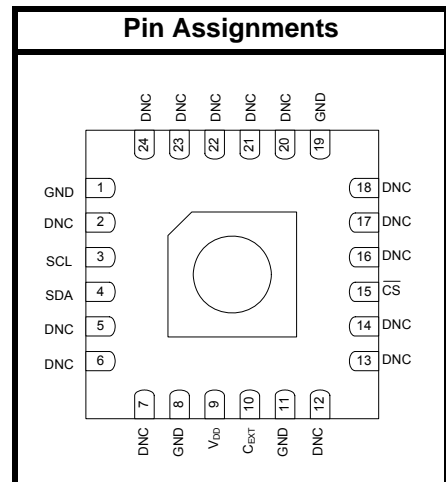

Si7005

Functional Block Diagram

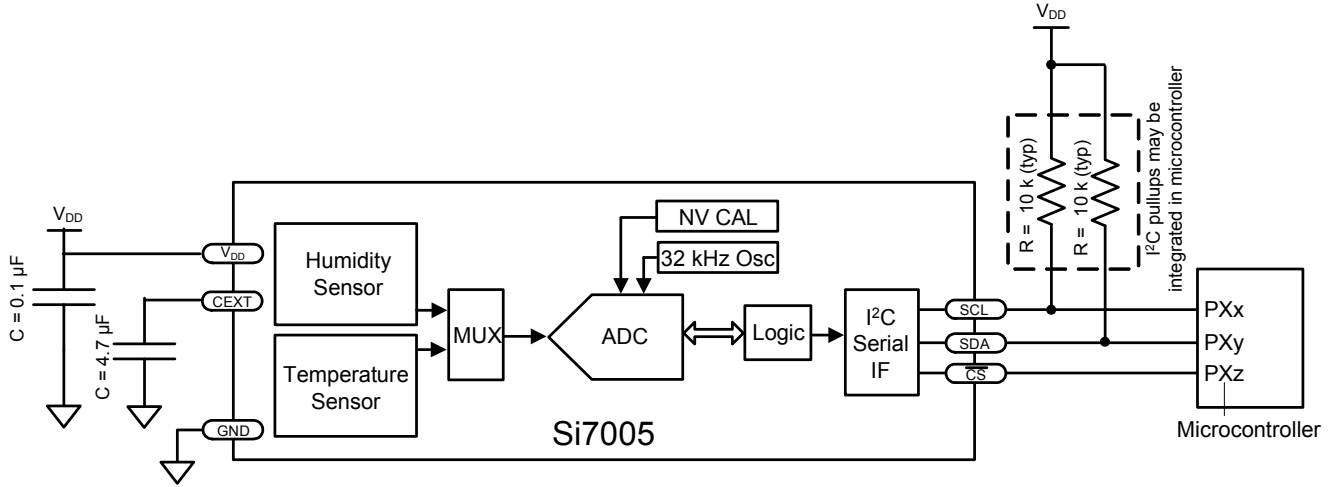

TABLE OF CONTENTS

| <u>Section</u> | <u>Page</u> |
|--|--------------------|
| 1. Electrical Specifications | 4 |
| 2. Typical Application Circuits | 10 |
| 3. Bill of Materials | 11 |
| 4. Functional Description | 12 |
| 4.1. Overview | 12 |
| 4.2. Relative Humidity Sensor Accuracy | 13 |
| 4.3. Linearization | 15 |
| 4.4. Temperature Compensation | 16 |
| 4.5. Hysteresis | 16 |
| 4.6. Prolonged Exposure to High Humidity | 16 |
| 4.7. PCB Assembly | 17 |
| 4.8. Protecting the Sensor | 18 |
| 4.9. Bake/Hydrate Procedure | 18 |
| 4.10. Long Term Drift/Aging | 18 |
| 5. Host Interface | 19 |
| 5.1. I2C Interface | 19 |
| 5.2. I2C Operation | 23 |
| 6. Si7005 Connection Diagrams | 25 |
| 7. Control Registers | 27 |
| 7.1. Register Detail (Defaults in Bold) | 27 |
| 8. Pin Descriptions: Si7005 | 30 |
| 9. Ordering Guide | 31 |
| 10. Package Outline | 32 |
| 10.1. 24-Pin QFN | 32 |
| 10.2. 24-Pin QFN with Protective Cover | 33 |
| 11. PCB Land Pattern and Solder Mask Design | 34 |
| 12. Top Marking | 36 |
| 12.1. Si7005 Top Marking | 36 |
| 12.2. Top Marking Explanation | 36 |
| 13. Additional Reference Resources | 37 |
| Document Change List | 38 |

Si7005

1. Electrical Specifications

Unless otherwise specified, all min/max specifications apply over the recommended operating conditions.

Table 1. Recommended Operating Conditions

| Parameter | Symbol | Test Condition | Min | Typ | Max | Unit |
|-----------------------|----------|----------------|-----|-----|-----|------|
| Power Supply | V_{DD} | | 2.1 | 3.3 | 3.6 | V |
| Operating Temperature | T_A | G grade | -40 | — | 85 | °C |
| Operating Temperature | T_A | F grade | 0 | — | 70 | °C |

Table 2. General Specifications

$2.1 \leq V_{DD} \leq 3.6$ V; $T_A = 0$ to 70 °C (F grade) or -40 to 85 °C (G grade) unless otherwise noted.

| Parameter | Symbol | Test Condition | Min | Typ | Max | Unit |
|---------------------|----------|---|---------------------|-----|---------------------|---------|
| Input Voltage High | V_{IH} | \overline{CS} , SCL, SDA pins | $0.7 \times V_{DD}$ | — | — | V |
| Input Voltage Low | V_{IL} | \overline{CS} , SCL, SDA pins | — | — | $0.3 \times V_{DD}$ | V |
| Input Voltage Range | V_{IN} | SCL, SDA pins with respect to GND | 0.0 | — | 3.6 | V |
| | | \overline{CS} , C_{EXT} pin with respect to GND | 0.0 | — | V_{DD} | V |
| Input Leakage | I_{IL} | \overline{CS} , SCL, SDA pins | — | — | ± 1 | μA |
| Output Voltage Low | V_{OL} | SDA pin; $I_{OL} = 8.5$ mA; $V_{DD} = 3.3$ V | — | — | 0.6 | V |
| | | SDA pin; $I_{OL} = 3.5$ mA; $V_{DD} = 2.1$ V | — | — | 0.4 | V |

Notes:

1. Si7005 can draw excess current if V_{DD} and \overline{CS} are ramped high together. To enter the lowest power mode, either hold \overline{CS} low while V_{DD} ramps or pulse \overline{CS} low after V_{DD} reaches its final value.
2. SDA and SCL pins have an internal 75 k Ω pull-up resistor to V_{DD} .

Table 2. General Specifications (Continued)

$2.1 \leq V_{DD} \leq 3.6$ V; $T_A = 0$ to 70 °C (F grade) or -40 to 85 °C (G grade) unless otherwise noted.

| Parameter | Symbol | Test Condition | Min | Typ | Max | Unit |
|---|---------------------|--|-----|-----|-----|---------|
| Power Consumption | I_{DD} | RH conversion in progress | — | 240 | 560 | μ A |
| | | Temperature conversion in progress | — | 320 | 565 | μ A |
| | | Average for 1 temperature and 1 RH conversion / minute | — | 1 | — | μ A |
| | | $\overline{CS} < V_{IL}$; no conversion in progress; $V_{DD} = 3.3$ V; $SDA = SCL \geq V_{IH}$ | — | 150 | — | μ A |
| | | $\overline{CS} > V_{IH}$ | — | — | 100 | μ A |
| | | $\overline{CS} < V_{IL}$; no conversion in progress; $V_{DD} = 3.3$ V; $SDA = SCL \geq V_{IH}$; HEAT = 1 | — | 24 | 31 | mA |
| Conversion Time | t_{CONV} | 14-bit temperature; 12-bit RH (Fast = 0) | | 35 | 40 | ms |
| | | 13-bit temperature; 11-bit RH (Fast = 1) | | 18 | 21 | |
| Wake Up Time | $t_{\overline{CS}}$ | From $\overline{CS} < V_{IL}$ to ready for a temp/RH conversion | | 10 | 15 | ms |
| Power Up Time | t_{PU} | From $V_{DD} \geq 2.1$ V to ready for a temp/RH conversion | | 10 | 15 | ms |
| Notes: | | | | | | |
| 1. Si7005 can draw excess current if V_{DD} and \overline{CS} are ramped high together. To enter the lowest power mode, either hold \overline{CS} low while V_{DD} ramps or pulse \overline{CS} low after V_{DD} reaches its final value. | | | | | | |
| 2. SDA and SCL pins have an internal 75 k Ω pull-up resistor to V_{DD} . | | | | | | |

Table 3. I²C Interface Specifications*

2.1 ≤ V_{DD} ≤ 3.6 V; T_A = 0 to 70 °C (F grade) or -40 to +85 °C (G grade) unless otherwise noted.

| Parameter | Symbol | Test Condition | Min | Typ | Max | Unit |
|----------------------------|---------------------|---|------------------------|-----|-----|------|
| Hysteresis | V _{HYS} | High-to-low versus low-to-high transition | 0.05 x V _{DD} | — | — | V |
| SCLK Frequency | f _{SCL} | | — | — | 400 | kHz |
| SCL high time | t _{SKH} | | 0.6 | — | — | μs |
| SCL low time | t _{SKL} | | 1.3 | — | — | μs |
| Start hold time | t _{STH} | | 0.6 | — | — | μs |
| Start setup time | t _{STS} | | 0.6 | — | — | μs |
| Stop setup time | t _{SPS} | | 0.6 | — | — | μs |
| Bus free time | t _{BUF} | Between Stop and Start | 1.3 | — | — | μs |
| SDA setup time | t _{DS} | | 100 | — | — | ns |
| SDA hold time | t _{DH} | | 100 | — | — | ns |
| SDA valid time | t _{VD;DAT} | From SCL low to data valid | — | — | 0.9 | μs |
| SDA acknowledge valid time | t _{VD;ACK} | From SCL low to data valid | — | — | 0.9 | μs |

***Note:** All values are referenced to V_{IL} and/or V_{IH}.

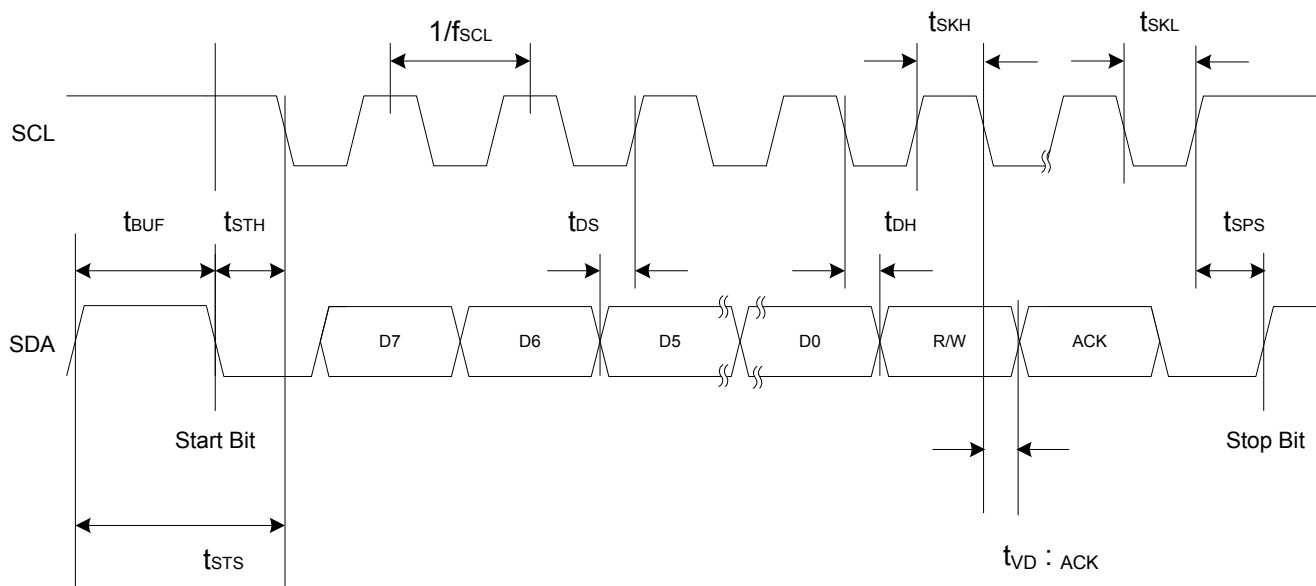

Figure 1. I²C Interface Timing Diagram

Table 4. Humidity Sensor

$2.1 \leq V_{DD} \leq 3.6$ V; $T_A = 25$ °C; $t_{CONV} = 35$ ms unless otherwise noted.

| Parameter | Symbol | Test Condition | Min | Typ | Max | Unit |
|----------------------------------|------------|----------------|--------------|-------|------|------------|
| Operating Range ¹ | | Non-condensing | 0 | — | 100 | %RH |
| Resolution ² | | | — | — | 12 | bit |
| Accuracy ^{3,4} | | 20–80% RH | — | ±3.0 | ±4.5 | %RH |
| | | 0–100% RH | See Figure 2 | | | |
| Repeatability—Noise | | | — | 0.05 | — | %RH RMS |
| Response Time ⁵ | τ 63% | 1 m/s airflow | — | 18 | — | s |
| Hysteresis | | | — | ±1 | — | %RH |
| Long Term Stability ⁴ | | | — | ≤0.25 | — | %RH/yr |

Notes:

1. Recommended humidity operating range is 20 to 80% RH (non-condensing) over 0 to 60 °C. Prolonged operation beyond these ranges may result in a shift of sensor reading, with slow recovery time.
2. The Si7005 has a nominal output of 16 codes per %RH, with 0h0000 = –24%RH.
3. Excludes hysteresis, long term drift, and certain other factors and is applicable to non-condensing environments only. See section “4.2. Relative Humidity Sensor Accuracy” for more details.
4. May be impacted by dust, vaporized solvents or other contaminants, e.g., out-gassing tapes, adhesives, packaging materials, etc. See section “4.10. Long Term Drift/Aging”.
5. Time for sensor output to reach 63% of its final value after a step change.

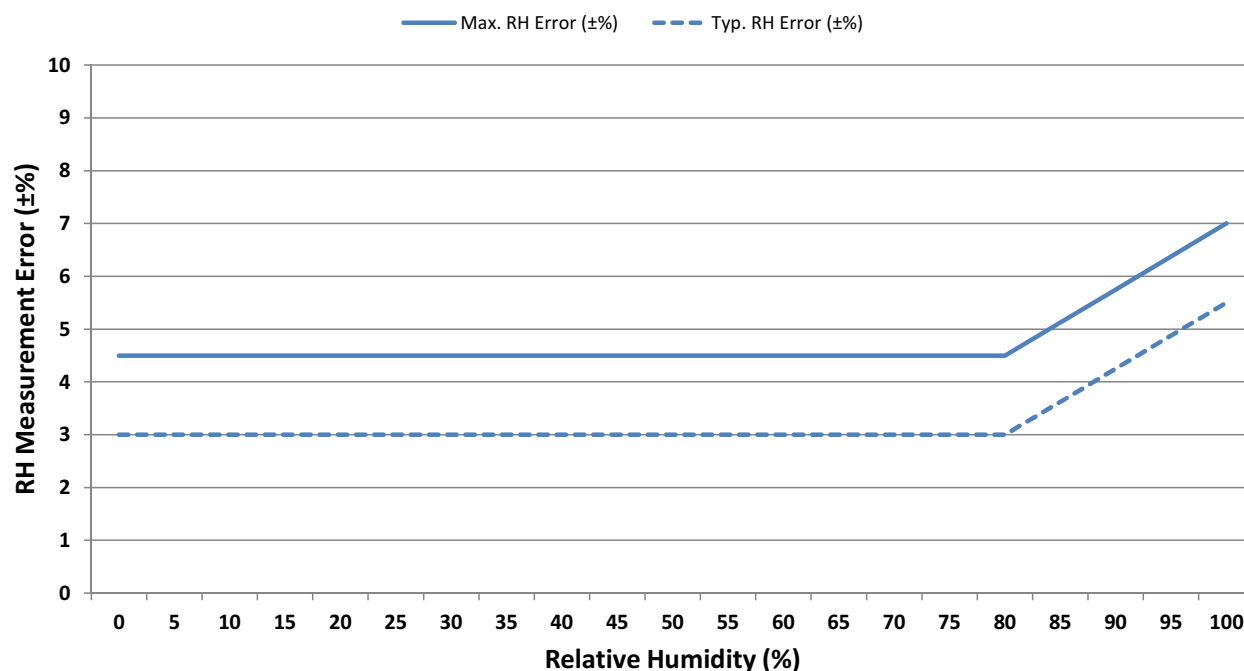
RH Accuracy**Figure 2. RH Accuracy at 30 °C**

Si7005

Table 5. Temperature Sensor

$2.1 \leq V_{DD} \leq 3.6$ V; $T_A = 0$ to 70 °C (F grade) or -40 to $+85$ °C (G grade); $t_{CONV} = 35$ ms unless otherwise noted.

| Parameter | Symbol | Test Condition | Min | Typ | Max | Unit |
|----------------------------|--------|----------------------------------|---------------|-------|------|-----------|
| Operating Range | | | -40 | — | 85 | °C |
| Resolution ¹ | | | — | — | 14 | Bit |
| | | | — | — | 1/32 | °C |
| Accuracy ² | | Typical at 25 °C | — | ±0.5 | ±1.0 | °C |
| | | Maximum | See Figure 3. | | | °C |
| Repeatability—Noise | | | — | 0.1 | — | °C RMS |
| Response Time ³ | | Time to reach 63% of final value | — | 1.5 | — | s |
| Long Term Stability | | | — | <0.05 | — | °C/yr |

Notes:

- The Si7005 has a nominal output of 32 codes /°C, with 0000 = -50 °C
- Temperature sensor accuracy is for $V_{DD} = 2.3$ to 3.6 V.
- Actual response times will vary dependent on system thermal mass and air-flow.

Temperature Accuracy

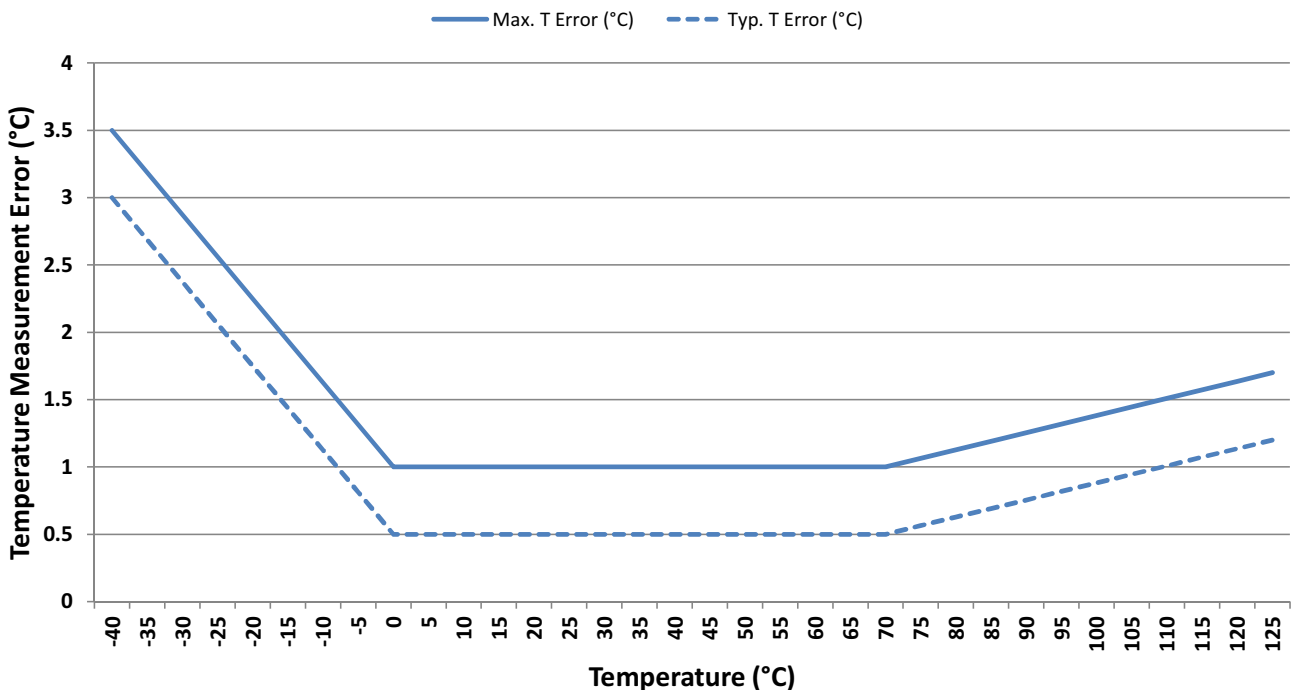

Figure 3. Temperature Accuracy

Table 6. Thermal Characteristics

| Parameter | Symbol | Test Condition | QFN-24 | Unit |
|------------------------------------|---------------|---|--------|------|
| Junction-to-Air Thermal Resistance | θ_{JA} | JEDEC 4-layer board | 55 | °C/W |
| Junction-to-Air Thermal Resistance | θ_{JA} | 2-layer evaluation PCB with minimal thermal pad | 110 | °C/W |

Table 7. Absolute Maximum Ratings^{1,2}

| Parameter | Symbol | Test Condition | Min | Typ | Max | Unit |
|--|--------|----------------|------|-----|----------------|------|
| Ambient Temperature under Bias | | | -55 | — | 125 | °C |
| Storage Temperature | | | -65 | — | 150 | °C |
| Voltage on SDA or SCL pin with respect to GND | | | -0.3 | — | 3.9 | V |
| Voltage on \overline{CS} pin with respect to GND | | | -0.3 | — | $V_{DD} + 0.3$ | V |
| Voltage on V_{DD} with respect to GND | | | -0.3 | — | 4.2 | V |
| ESD Tolerance | | HBM | — | — | 3 | kV |
| | | CDM | — | — | 750 | V |
| | | MM | — | — | 300 | V |

Notes:

1. Absolute maximum ratings are stress ratings only; operation at or beyond these conditions is not implied and may shorten the life of the device or alter its performance.
2. For best accuracy, after removal from the sealed shipping bags, the Si7005 should be stored in climate controlled conditions (10 to 35 °C, 20 to 60 %RH). Exposure to high temperature and/or high humidity environments can cause a small upwards shift in RH readings.

2. Typical Application Circuits

Note: If the Si7005 shares an I²C bus with other slave devices, it should be powered down when the master controller is communicating with the other slave devices.

The Si7005 can be powered down either by setting the \overline{CS} signal to logic high or setting the VDD pin to 0 V. Refer to Figure 5 for an illustration of this method of powering the Si7005 from an MCU GPIO (the Si7005 VDD is powered from an MCU port pin).

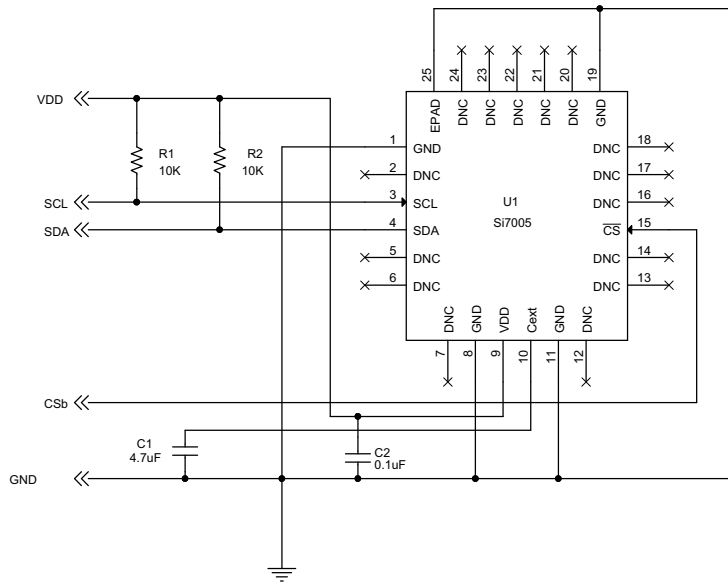

Figure 4. Typical Application Circuit

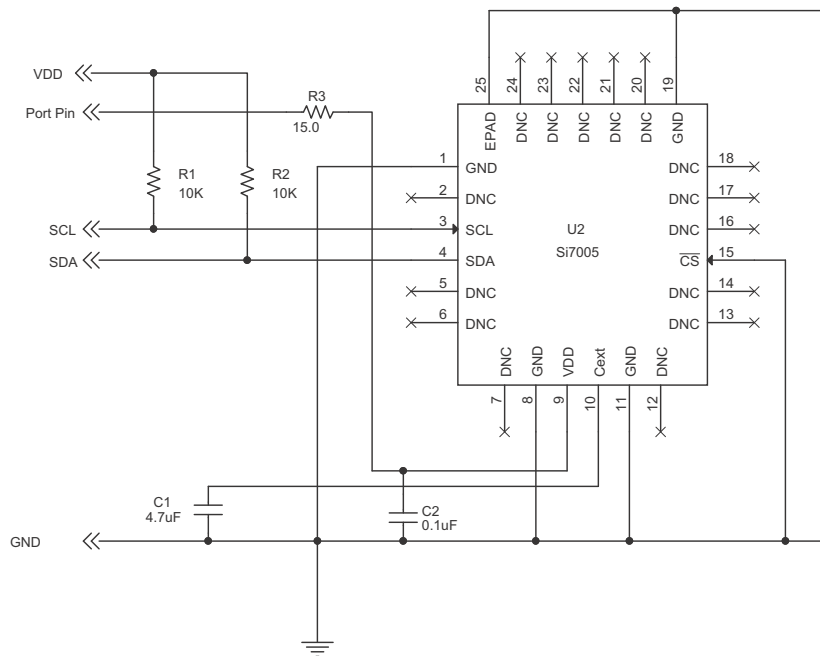

Figure 5. Typical Application Circuit for Battery-Powered Applications

3. Bill of Materials

Table 8. Typical Application Circuit BOM

| Reference | Description | Mfr Part Number | Manufacturer |
|-----------|---|------------------|--------------|
| C1 | Capacitor, 4.7 μ F, 6.3 V, X5R, 0603 | C0603X5R6R3-475M | Venkel |
| C2 | Capacitor, 0.1 μ F, 6.3 V, X7R, 0603 | C0603X7R6R3-104M | Venkel |
| R1* | Resistor, 10 k Ω , \pm 5%, 1/16W, 0603 | CR0603-16W-1002J | Venkel |
| R2* | Resistor, 10 k Ω , \pm 5%, 1/16W, 0603 | CR0603-16W-1002J | Venkel |
| U1 | IC, digital temperature/humidity sensor | Si7005 | Silicon Labs |

***Note:** Typical value shown. Optimal value depends on bus capacitance and speed of bus operation; not needed if present elsewhere in the system.

Table 9. Typical Application Circuit for Battery-Powered Applications BOM

| Reference | Description | Mfr Part Number | Manufacturer |
|-----------|---|------------------|--------------|
| C1 | Capacitor, 4.7 μ F, 6.3 V, X5R, 0805 | C0805X5R160-475M | Venkel |
| C2 | Capacitor, 0.1 μ F, 6.3 V, X7R, 0603 | C0603X7R6R3-104M | Venkel |
| R1* | Resistor, 10 k Ω , \pm 5%, 1/16W, 0603 | CR0603-16W-1002J | Venkel |
| R2* | Resistor, 10 k Ω , \pm 5%, 1/16W, 0603 | CR0603-16W-1002J | Venkel |
| R3 | Resistor, 15 Ω , \pm 5%, 1/16W, 0603 | CR0603-16W-15R0J | Venkel |
| U1 | IC, digital temperature/humidity sensor | Si7005 | Silicon Labs |

***Note:** Typical value shown. Optimal value depends on bus capacitance and speed of bus operation; not needed if present elsewhere in the system.

4. Functional Description

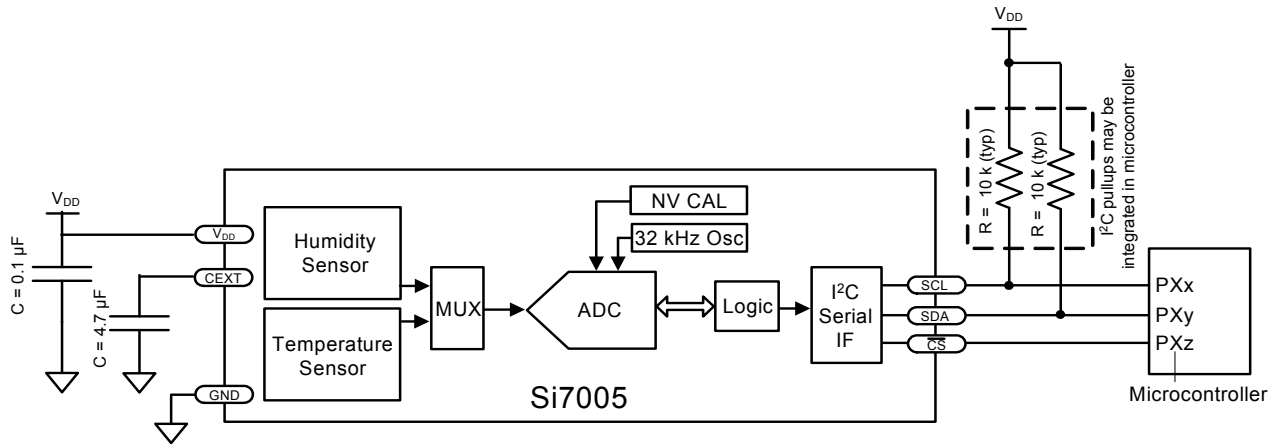

Figure 6. Si7005 Functional Block Diagram

4.1. Overview

The Si7005 is a digital relative humidity and temperature sensor. This monolithic CMOS IC integrates temperature and humidity sensor elements, an analog-to-digital converter, signal processing, calibration data, and an I²C host interface. Both the temperature and humidity sensors on each unit are factory-calibrated and the calibration data is stored in the on-chip non-volatile memory. This ensures that the sensors are fully interchangeable, with no recalibration or software changes required.

While the Si7005 is largely a conventional mixed-signal CMOS integrated circuit, relative humidity sensors in general and those based on capacitive sensing using polymeric dielectric have unique application and use requirements that are not common to conventional (non-sensor) ICs. Chief among those are:

- The need to protect the sensor during board assembly, i.e., solder reflow, and the need to subsequently rehydrate the sensor.
- The need to protect the sensor from damage or contamination during the product life-cycle
- The impact of prolonged exposure to extremes of temperature and/or humidity and their potential affect on sensor accuracy
- The effects of humidity sensor “memory”
- The need to apply temperature correction and linearization to the humidity readings

Each of these items is discussed in more detail in the following sections.

4.2. Relative Humidity Sensor Accuracy

To determine the accuracy of a relative humidity sensor, it is placed in a temperature and humidity controlled chamber. The temperature is set to a convenient fixed value (typically 30 °C) and the relative humidity is swept from 20 to 80% and back to 20% in the following steps: 20% – 40% – 60% – 80% – 80% – 60% – 40% – 20%. At each set-point, the chamber is allowed to settle for a period of 30 minutes before a reading is taken from the sensor. Prior to the sweep, the device is allowed to stabilize to 50%RH. The solid top and bottom trace in Figure 7, "Measuring Sensor Accuracy Including Hysteresis," shows the result of a typical sweep after non-linearity compensation.

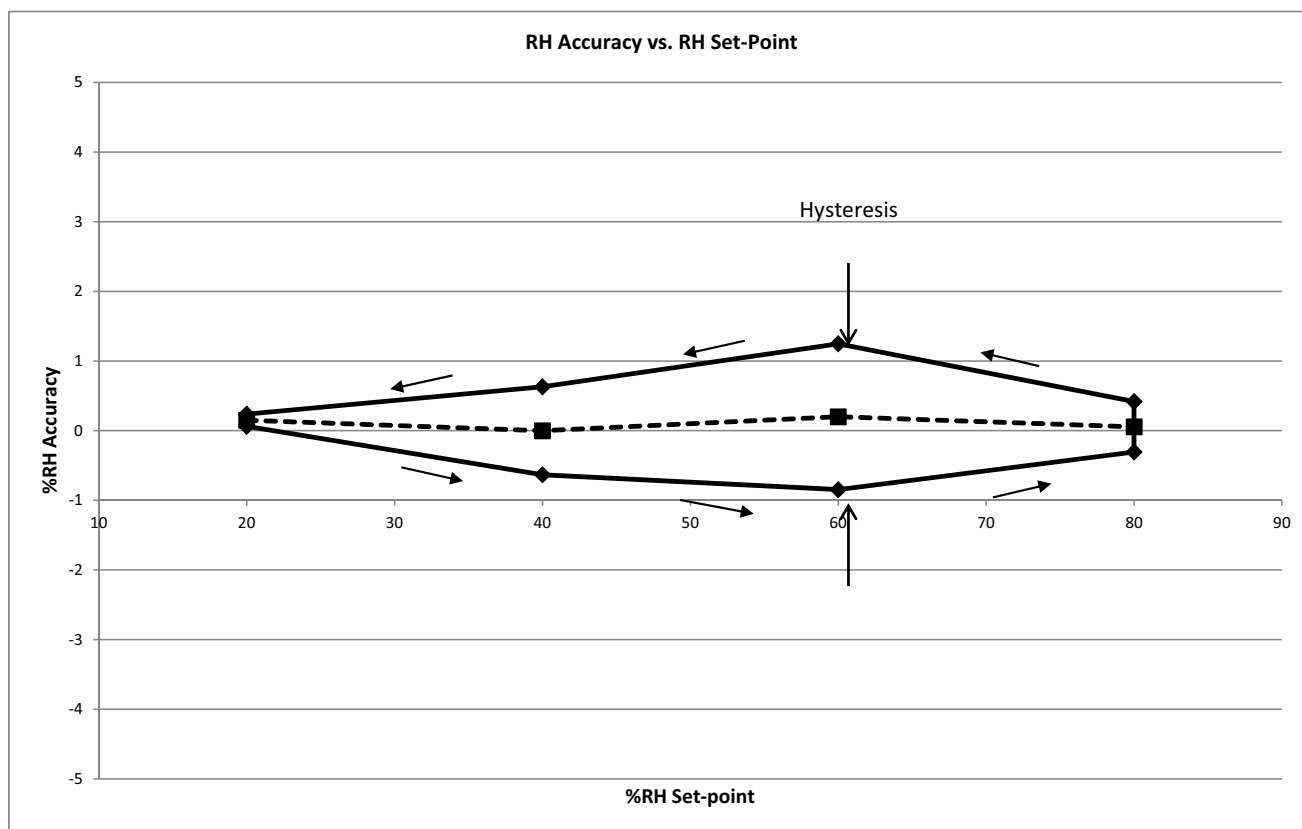

Figure 7. Measuring Sensor Accuracy Including Hysteresis

Si7005

The RH accuracy is defined as the center (dashed) line shown in Figure 7, which is the average of the two data points at each relative humidity set-point. In this case, the sensor shows an accuracy of 0.25%RH. The Si7005 accuracy specification (Table 4) includes:

- Unit-to-unit and lot-to-lot variation in non-linearity compensation
- Accuracy of factory calibration
- Margin for shifts that can occur during solder reflow (compensation for shift due to reflow is included in the linearization procedure below).

The accuracy specification does not include:

- Hysteresis (typically $\pm 1\%$)
- Effects from long term exposure to very humid conditions
- Contamination of the sensor by particulates, chemicals, etc.
- Other aging related shifts (“Long-term stability”)
- Variations due to temperature (a temperature compensation method is described in section “4.4. Temperature Compensation”). After application of temperature compensation, RH readings will typically vary by less than $\pm 0.05\%/^{\circ}\text{C}$.

4.3. Linearization

Capacitive relative humidity sensors require linearization. The Si7005 accuracy specification (Table 4) applies after correction of non-linearity errors. The recommended linearization technique is to correct the measured relative humidity value with a 2nd order polynomial; the linear relative humidity (RH) value is calculated as follows:

$$RH_{\text{Linear}} = RH_{\text{Value}} - ((RH_{\text{Value}})^2 \times A_2 + RH_{\text{Value}} \times A_1 + A_0)$$

Where:

- RH_{Linear} is the corrected relative humidity value in %RH
- RH_{Value} is the uncorrected (measured) relative humidity value in %RH
- A_2 , A_1 , and A_0 are unit-less correction coefficients derived through characterization of Si7005s by Silicon Laboratories; their values depend on whether compensation for a typical solder reflow is required

The values for the correction coefficients are shown in Table 10.

Table 10. Linearization Coefficients

| Coefficient | Value |
|-------------|----------|
| A_0 | -4.7844 |
| A_1 | 0.4008 |
| A_2 | -0.00393 |

4.4. Temperature Compensation

The Si7005 relative humidity sensor is calibrated at a temperature of 30 °C; it is at this temperature that the sensor will give the most accurate relative humidity readings. For relative humidity measurements at other temperatures, the RH reading from the Si7005 must be compensated for the change in temperature relative to 30 °C. Temperature compensated relative humidity readings can be calculated as follows:

$$RH_{TempCompensated} = RH_{Linear} + (Temperature - 30) \times (RH_{Linear} \times Q_1 + Q_0)$$

Where:

- $RH_{TempCompensated}$ is the temperature compensated relative humidity value in %RH.
- RH_{Linear} is the linear corrected relative humidity value in %RH.
- Temperature is the ambient temperature in °C as measured by the Si7005 on chip temperature sensor.
- Q_1 and Q_0 are unit-less correction coefficients derived through characterization of Si7005s by Silicon Laboratories.

This temperature compensation is most accurate in the range of 15–50 °C. The values for the correction coefficients are shown in Table 11.

Table 11. Linearization Coefficients

| Coefficient | Value |
|-------------|---------|
| Q_0 | 0.1973 |
| Q_1 | 0.00237 |

4.5. Hysteresis

The moisture absorbent film (polymeric dielectric) of the humidity sensor will carry a memory of its exposure history, particularly its recent or extreme exposure history. A sensor exposed to relatively low humidity will carry a negative offset relative to the factory calibration, and a sensor exposed to relatively high humidity will carry a positive offset relative to the factory calibration. This factor causes a hysteresis effect illustrated by the solid top and bottom traces in Figure 7. The hysteresis value is the difference in %RH between the maximum absolute error on the decreasing humidity ramp and the maximum absolute error on the increasing humidity ramp at a single relative humidity Setpoint and is expressed as a bipolar quantity relative to the average, the center dashed trace in Figure 7. In the case of Figure 7, the measurement uncertainty due to the hysteresis effect is $\pm 1.05\%$ RH.

4.6. Prolonged Exposure to High Humidity

Prolonged exposure to high humidity will result in a gradual upward drift of the RH reading. The shift in sensor reading resulting from this drift will generally disappear slowly under normal ambient conditions. The amount of shift is proportional to the magnitude of relative humidity and the length of exposure. In the case of lengthy exposure to high humidity, some of the resulting shift may persist indefinitely under typical conditions. It is generally possible to substantially reverse this affect by baking the device (see section “4.9. Bake/Hydrate Procedure”).

4.7. PCB Assembly

4.7.1. Soldering

Like most ICs, Si7005 devices are shipped from the factory vacuum-packed with an enclosed desiccant to avoid any drift during storage and to prevent any moisture-related issues during solder reflow. Devices should be soldered using reflow and a “no clean” solder process, as a water or solvent rinse after soldering may affect accuracy. See "11. PCB Land Pattern and Solder Mask Design" on page 34 for the recommended card reflow profile.

It is essential that the exposed polymer sensing film be kept clean and undamaged. It is recommended that a protective cover of some kind be in place during PCB assembly. Kapton®* polyimide tape is recommended as a protective cover. See Table 12 below for examples of tape products that may be used for protection during the soldering operation.

Alternatively, Si7005s may be ordered with a factory-fitted, solder-resistant protective cover that can be left in place for the lifetime of the product, preventing liquids, dust, or other contaminants from coming into contact with the polymer sensor film. See "9. Ordering Guide" on page 31 for a list of ordering part numbers that include the cover.

4.7.2. Rehydration

The measured humidity value will generally shift slightly after solder reflow. A portion of this shift is permanent and is accounted for when using the linearization procedure given above. After soldering, an Si7005 should be allowed to equilibrate under controlled RH conditions (room temperature, 45–55%RH) for at least 48 hours to eliminate the remainder of the shift and return the device to its specified accuracy performance.

4.7.3. Rework

To maintain the specified sensor performance, care must be taken during rework to minimize the exposure of the device to excessive heat and to avoid damage/contamination or a shift in the sensor reading due to liquids, solder flux, etc. Manual touch-up using a soldering iron is permissible under the following guidelines:

- The exposed polymer sensing film must be kept clean and undamaged. A protective cover is recommended during any rework operation (Kapton® tape or the factory-installed cover).
- Flux must not be allowed to contaminate the sensor; liquid flux is not recommended even with a cover in place. Conventional lead-free solder with rosin core is acceptable for touch-up as long as a cover is in place during the rework.
- Avoid water or solvent rinses after touch-up.
- Minimize the heating of the device. It is recommended that soldering iron temperatures not exceed 350 °C and that the contact time per pin does not exceed five seconds.

Hot air rework is not recommended. If a device must be replaced, remove the device by hot air and solder a new part in its place by reflow following the guidelines above.

***Note:** All trademarks are the property of their respective owners.

Table 12. Tape Products for Protection During Soldering

| Manufacturer Part Number* | Manufacturer |
|--|----------------|
| KPPD-1/8 | Kaptontape.com |
| *Note: Provided for information only. | |



Figure 8. Si7005 with Factory-Installed Protective Cover

4.8. Protecting the Sensor

Because the sensor operates on the principal of measuring a change in capacitance, any changes to the dielectric constant of the polymer film will be detected as a change in relative humidity. Therefore, it is important to minimize the probability of contaminants coming into contact with the sensor. Dust and other particles as well as liquids can affect the RH reading. It is recommended that a cover is employed in the end system that blocks contaminants but allows water vapor to pass through. Depending on the needs of the application, this can be as simple as plastic or metallic gauze for basic protection against particulates or something more sophisticated such as a hydrophobic membrane providing up to IP67 compliant protection.

The Si7005 may be ordered with a factory-fitted, solder-resistant cover that can be left in place for the lifetime of the product. It is very low-profile, hydrophobic and oleophobic. See Section “9. Ordering Guide” for a list of ordering part numbers that include the cover. A dimensioned drawing of the IC with the cover is included in Section “10. Package Outline”. Other characteristics of the cover are listed in the table below.

Table 13. Specifications of Protective Cover

| Parameter | Value |
|----------------------------|----------------|
| Material | PTFE |
| Operating Temperature | -40 to +125 °C |
| Maximum Reflow Temperature | 260 °C |
| IP Rating (per IEC 529) | IP67 |

4.9. Bake/Hydrate Procedure

After exposure to extremes of temperature and/or humidity for prolonged periods, the polymer sensor film can become either very dry or very wet, in each case the result is either high or low relative humidity readings. Under normal operating conditions, the induced error will diminish over time. From a very dry condition, such as after shipment and soldering, the error will diminish over a few days at typical controlled ambient conditions, e.g., 48 hours of $45 \leq \%RH \leq 55$. However, from a very wet condition, recovery may take significantly longer. To accelerate recovery from a wet condition, a bake and hydrate cycle can be implemented. This operation consists of the following steps:

- Baking the sensor at 125 °C for ≥ 12 hours
- Hydration at 30 °C in 75 %RH for ≥ 10 hours

Following this cycle, the sensor will return to normal operation in typical ambient conditions after a few days.

4.10. Long Term Drift/Aging

Over long periods of time, the sensor readings may drift due to aging of the device. Standard accelerated life testing of the Si7005 has resulted in the specifications for long-term drift shown in Table 4 and Table 5. This contribution to the overall sensor accuracy accounts only for the long-term aging of the device in an otherwise benign operating environment and does not include the affects of damage, contamination, or exposure to extreme environmental conditions.

5. Host Interface

5.1. I²C Interface

The Si7005 has an I²C serial interface with a 7-bit address of 0x40. The Si7005 is a slave device supporting data transfer rates up to 400 kHz. Table 24 shows the register summary of the Si7005.

5.1.1. Performing a Relative Humidity Measurement

The following steps should be performed in sequence to take a relative humidity measurement:

1. Set START (D0) in CONFIG to begin a new conversion
2. Poll RDY (D0) in STATUS (register 0) until it is low (= 0)
3. Read the upper and lower bytes of the RH value from DATAh and DATAl (registers 0x01 and 0x02), respectively. Table 14 shows the format of the 12-bit relative humidity result.
4. Convert the RH value to %RH using the following equation:

$$\%RH = \left(\frac{RH}{16} \right) - 24$$

where RH is the measured value returned in DATAh:DATAI

5. Apply temperature compensation and/or linearization as discussed elsewhere in this data sheet

Table 15 shows the 12-bit values that correspond to various measured RH levels.

Table 14. 12-Bit Relative Humidity Result Available in Registers 1 and 2

| DATAh | | | | | | | | DATAI | | | | | | | |
|-------------------------------|----|----|----|----|----|----|----|-------|----|----|----|----|----|----|----|
| D7 | D6 | D5 | D4 | D3 | D2 | D1 | D0 | D7 | D6 | D5 | D4 | D3 | D2 | D1 | D0 |
| 12-Bit Relative Humidity Code | | | | | | | | | | | | 0 | 0 | 0 | 0 |

Table 15. Typical %RH Measurement Codes for 0 to 100% RH Range

| %RH | 12 Bit Code | |
|-----|-------------|-----|
| | Dec | Hex |
| 0 | 384 | 180 |
| 10 | 544 | 220 |
| 20 | 704 | 2C0 |
| 30 | 864 | 360 |
| 40 | 1024 | 400 |
| 50 | 1184 | 4A0 |
| 60 | 1344 | 540 |
| 70 | 1504 | 5E0 |
| 80 | 1664 | 680 |
| 90 | 1824 | 720 |
| 100 | 1984 | 7C0 |

The above sequence assumes normal mode, i.e., $t_{CONV} = 35$ ms (typical). Conversions may be performed in fast mode. See section "5.1.3. Fast Conversion Mode".

5.1.2. Performing a Temperature Measurement

The following steps should be performed in sequence to take a temperature measurement:

6. Set START (D0) and TEMP (D4) in CONFIG (register 0x03) to begin a new conversion, i.e., write CONFIG with 0x11
7. Poll RDY (D0) in STATUS (register 0) until it is low (=0)
8. Read the upper and lower bytes of the temperature value from DATAh and DATAl (registers 0x01 and 0x02), respectively

Table 16 shows the format of the 14-bit temperature result. This value may be converted to °C using the following equation:

$$\text{Temperature}(\text{°C}) = \left(\frac{\text{TEMP}}{32} \right) - 50$$

where TEMP is the measured value returned in DATAh:DATAI.

Table 17 shows the 14-bit values that correspond to various measured temperature levels.

Table 16. 14-Bit Temperature Result Available in Registers 1 and 2

| DATAh | | | | | | | | DATAI | | | | | | | |
|-------------------------|----|----|----|----|----|----|----|-------|----|----|----|----|----|----|----|
| D7 | D6 | D5 | D4 | D3 | D2 | D1 | D0 | D7 | D6 | D5 | D4 | D3 | D2 | D1 | D0 |
| 14-Bit Temperature Code | | | | | | | | | | | | | | 0 | 0 |

The above sequence assumes normal mode, i.e., $t_{\text{CONV}} = 35$ ms (typical). Conversions may be performed in fast mode. See section “5.1.3. Fast Conversion Mode”.

Table 17. Typical Temperature Measurement Codes for the -40 °C to 100 °C Range

| Temp(°C) | 14 Bit Code | |
|----------|-------------|------|
| | Dec | Hex |
| -40 | 320 | 0140 |
| -30 | 640 | 0280 |
| -20 | 960 | 03C0 |
| -10 | 1280 | 0500 |
| 0 | 1600 | 0640 |
| 10 | 1920 | 0780 |
| 20 | 2240 | 08C0 |
| 30 | 2560 | 0A00 |
| 40 | 2880 | 0B40 |
| 50 | 3200 | 0C80 |
| 60 | 3520 | 0DC0 |
| 70 | 3840 | 0F00 |
| 80 | 4160 | 1040 |
| 90 | 4480 | 1180 |
| 100 | 4800 | 12C0 |

5.1.3. Fast Conversion Mode

The time needed to perform a temperature or RH measurement can be reduced from 35 ms (typical) to 18 ms (typical) by setting FAST (D5) in CONFIG (register 0x03). Fast mode reduces the total power consumed during a conversion or the average power consumed by the Si7005 when making periodic conversions. It also reduces the resolution of the measurements. Table 18 is a comparison of the normal and fast modes.

Table 18. Normal vs. Fast Mode

| Parameter | Value | |
|-----------------------------|-------------|-----------|
| | Normal Mode | Fast Mode |
| t _{CONV} (typical) | 35 ms | 18 ms |
| Temperature resolution | 14-bit | 13-bit |
| RH resolution | 12-bit | 11-bit |

5.1.4. Heater

The Si7005 relative humidity sensor contains an integrated, resistive heating element that may be used to raise the temperature of the humidity sensor. This element can be used to drive off condensation or to implement dew-point measurement when the Si7005 is used in conjunction with a separate temperature sensor such as another Si7005.

The heater can be activated by setting HEAT (D1) in CONFIG (register 0x03). Turning on the heater will reduce the tendency of the humidity sensor to accumulate an offset due to “memory” of sustained high humidity conditions. When the heater is enabled, the reading of the on-chip temperature sensor will be affected (increased).

5.1.5. Device Identification

The Si7005 device and its revision level can be determined by reading ID (register 0x11). Table 19 lists the values for the various device revisions and may include revisions not yet in existence.

Table 19. Device ID Revision Values

| Device ID Value | | Device Type | Revision Level |
|-----------------|--------|-------------|----------------|
| D[7:4] | D[3:0] | | |
| 0101 | 0000 | Si7005 | B |

5.2. I²C Operation

The Si7005 uses a digital I²C interface. If the Si7005 shares an I²C bus with other slave devices, it should be powered down when the master controller is communicating with the other slave devices. The Si7005 can be powered down either by setting the \overline{CS} signal to logic high or setting the VDD pin to 0 V. A method of achieving this by powering the Si7005 from an MCU GPIO is shown in Figure 5.

The format of the address byte is shown in Table 20.

Table 20. I²C Slave Address Byte

| A6 | A5 | A4 | A3 | A2 | A1 | A0 | R/W |
|----|----|----|----|----|----|----|-----|
| 1 | 0 | 0 | 0 | 0 | 0 | 0 | 1/0 |

5.2.1. I²C Write Operation

To write to a register on the Si7005, the master should issue a start command (S) followed by the slave address, 0x40. The slave address is followed by a 0 to indicate that the operation is a write. Upon recognizing its slave address, the Si7005 issues an acknowledge (A) by pulling the SDA line low for the high duration of the ninth SCL cycle. The next byte the master places on the bus is the register address pointer, selecting the register on the Si7005 to which the data should be transferred. After the Si7005 acknowledges this byte, the master places a data byte on the bus. This byte will be written to the register selected by the address pointer. The Si7005 will acknowledge the data byte, after which the master issues a Stop command (P). See Table 21.

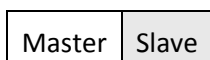

Table 21. I²C Write Sequence

Sequence to Write to a Register

| | | | | | | | | |
|---|---------------|---|---|-----------------|---|---------------|---|---|
| S | Slave Address | W | A | Address Pointer | A | Register Data | A | P |
|---|---------------|---|---|-----------------|---|---------------|---|---|

Sequence to Start a Relative Humidity Conversion

| | | | | | | | | |
|---|------|---|---|------|---|------|---|---|
| S | 0x40 | 0 | A | 0x03 | A | 0x01 | A | P |
|---|------|---|---|------|---|------|---|---|

Sequence to Start a Temperature Conversion

| | | | | | | | | |
|---|------|---|---|------|---|------|---|---|
| S | 0x40 | 0 | A | 0x03 | A | 0x11 | A | P |
|---|------|---|---|------|---|------|---|---|

5.2.2. I²C Read Operation

To read a register on the Si7005, the master must first set the address pointer to indicate the register from which the data is to be transferred. Therefore, the first communication with the Si7005 is a write operation. The master should issue a start command (S) followed by the slave address, 0x40. The slave address is followed by a 0 to indicate that the operation is a write. Upon recognizing its slave address, the Si7005 will issue an acknowledge (A) by pulling the SDA line low for the high duration of the ninth SCL cycle. The next byte the master places on the bus is the register address pointer selecting the register on the Si7005 from which the data should be transferred. After the Si7005 acknowledges this byte, the master issues a repeated start command (Sr) indicating that a new transfer is to take place. The Si7005 is addressed once again with the R/W bit set to 1, indicating a read operation. The Si7005 will acknowledge its slave address and output data from the previously-selected register onto the data bus under the control of the SCL signal, the master should not acknowledge (\bar{A}) the data byte and issue a stop (P) command (see Table 22). However, if a RH or Temperature conversion result (two bytes) is to be read, the master should acknowledge (A) the first data byte and continue to activate the SCL signal. The Si7005 will automatically output the second data byte. Upon receiving the second byte, the master should issue a not Acknowledge (A) followed by a stop command. (See Table 23).

Table 22. I²C Read Sequence for a Single Register

Sequence to Read from a Single Register

| | | | | | | | | | | | | |
|---|---------------|---|---|-----------------|---|----|---------------|---|---|---------------|-----------|---|
| S | Slave Address | W | A | Address Pointer | A | Sr | Slave Address | R | A | Register Data | \bar{A} | P |
|---|---------------|---|---|-----------------|---|----|---------------|---|---|---------------|-----------|---|

Sequence to Read Device ID

| | | | | | | | | | | | | |
|---|------|---|---|------|---|----|------|---|---|----|-----------|---|
| S | 0x40 | 0 | A | 0x11 | A | Sr | 0x40 | 1 | A | ID | \bar{A} | P |
|---|------|---|---|------|---|----|------|---|---|----|-----------|---|

Sequence to Read \overline{RDY} bit

| | | | | | | | | | | | | | |
|---|------|---|---|------|---|----|------|---|---|---|------------------|-----------|---|
| S | 0x40 | 0 | A | 0x00 | A | Sr | 0x40 | 1 | A | — | \overline{RDY} | \bar{A} | P |
|---|------|---|---|------|---|----|------|---|---|---|------------------|-----------|---|

Table 23. I²C Read Sequence for RH or Temperature Conversion Result

Sequence to Read Conversion Result

| | | | | | | | | | | | | | | |
|---|---------------|---|---|-----------------|---|----|---------------|---|---|-----------------|---|-----------------|-----------|---|
| S | Slave Address | W | A | Address Pointer | A | Sr | Slave Address | R | A | Register 1 Data | A | Register 2 Data | \bar{A} | P |
|---|---------------|---|---|-----------------|---|----|---------------|---|---|-----------------|---|-----------------|-----------|---|

| | | | | | | | | | | | | | | |
|---|------|---|---|------|---|----|------|---|---|--------|---|--------|-----------|---|
| S | 0x40 | 0 | A | 0x01 | A | Sr | 0x40 | 1 | A | Data H | A | Data L | \bar{A} | P |
|---|------|---|---|------|---|----|------|---|---|--------|---|--------|-----------|---|

6. Si7005 Connection Diagrams

The Si7005 is a simple-to-use device requiring a minimum of external components. Figure 9 shows the typical connection diagram for the Si7005 connected to an MCU. (Refer to section “8. Pin Descriptions: Si7005” for full pin descriptions). The values for the two I²C pull-up resistors depend on the capacitance of the I²C bus lines and the desired speed of operation. Refer to the I²C specification for further details. In this diagram \overline{CS} is shown controlled by the MCU, allowing the Si7005 to be placed in standby mode when not in use. A detailed schematic and bill-of-materials for this circuit can be found in section “2. Typical Application Circuits” and section “3. Bill of Materials”.

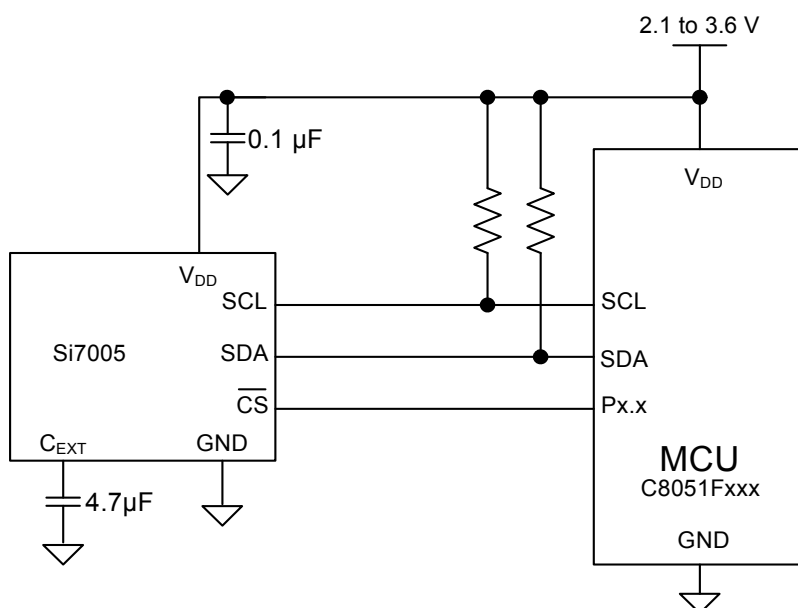

Figure 9. Typical Connection Diagram

For ultra-low-power operation, such as in battery-powered applications, connection as shown in Figure 10 is recommended. In this case, the Si7005 is powered from one of the MCU's GPIOs. The GPIO can be driven high to powerup the Si7005, once the measurement results are obtained, the GPIO can be driven low to power-down the Si7005, reducing its current consumption to zero. The GPIO must be capable of sourcing 320 µA for the duration of the conversion time (<200 ms for relative humidity and temperature conversions) and up to 40 mA for a period of 5 ms at power-up. The GPIO must also be capable of sinking up to 40 mA for a period of 5 ms at powerdown. The purpose of the 15 Ω resistor is to isolate the Si7005 from potential high-frequency switching noise present on the MCU GPIO. A detailed schematic and bill-of-materials for this circuit can be found in section “2. Typical Application Circuits” and section “3. Bill of Materials”.

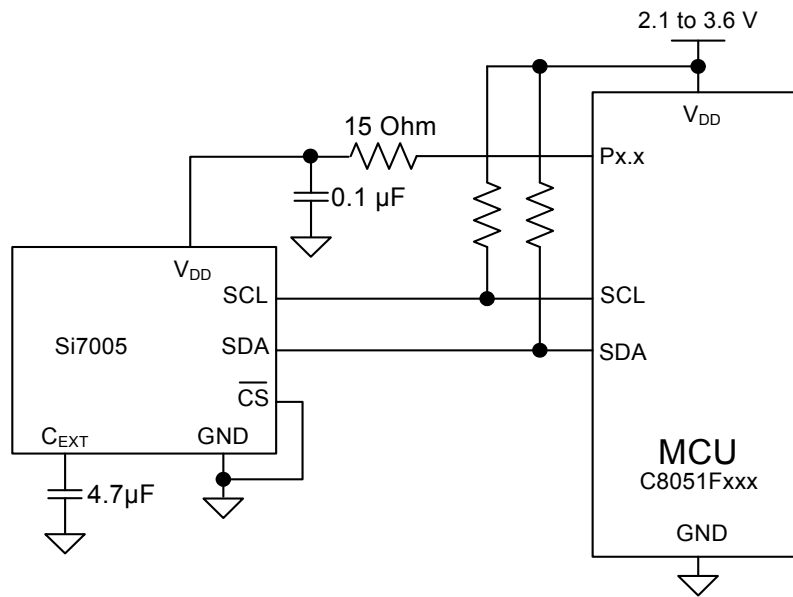

Figure 10. Recommended Connection Diagram for Low-Power Battery Operation

7. Control Registers

Table 24 contains a summary of the Si7005 register set. Each register is described in more detail below.

Table 24. Si7005 Register Summary

| Register | Name | Bit 7 | Bit 6 | Bit 5 | Bit 4 | Bit 3 | Bit 2 | Bit 1 | Bit 0 |
|---|--------|---|-------|-------|-------|-------|-------|-------|-------|
| I ² C Register Summary | | | | | | | | | |
| 0 | STATUS | RSVD | RSVD | RSVD | RSVD | RSVD | RSVD | RSVD | /RDY |
| 1 | DATAh | Relative Humidity or Temperature, High Byte | | | | | | | |
| 2 | DATAI | Relative Humidity or Temperature, Low Byte | | | | | | | |
| 3 | CONFIG | RSVD | RSVD | FAST | TEMP | RSVD | RSVD | HEAT | START |
| 17 | ID | ID3 | ID2 | ID1 | ID0 | 0 | 0 | 0 | 0 |
| Notes: <ol style="list-style-type: none"> Any register address not listed here is reserved and must not be written. Reserved register bits (RSVD) must always be written as zero; the result of a read operation on these bits is undefined. | | | | | | | | | |

7.1. Register Detail (Defaults in Bold)

Register 0. STATUS

| Bit | D7 | D6 | D5 | D4 | D3 | D2 | D1 | D0 |
|------|----|----|----|----|----|----|----|------|
| Name | | | | | | | | /RDY |
| Type | R | | | | | | | |

Reset Settings = 0000_0001

| Bit | Name | Function |
|-----|----------|--|
| 7:1 | Reserved | Reserved. Reads undefined. |
| 0 | /RDY | Ready. 0 = conversion complete; results available in DATAh:DATAI. 1 = conversion in progress. |

Si7005

Register 1. DATAh

| Bit | D7 | D6 | D5 | D4 | D3 | D2 | D1 | D0 |
|------|---|----|----|----|----|----|----|----|
| Name | Relative Humidity or Temperature, High Byte | | | | | | | |
| Type | R | | | | | | | |

Reset Settings = 0000_0000

| Bit | Name | Function |
|-----|-------|---|
| 7:0 | DATAh | Data, High Byte. Eight most significant bits of a temperature or humidity measurement. See Table 14 or Table 16 for the measurement format. |

Register 2. DATAI

| Bit | D7 | D6 | D5 | D4 | D3 | D2 | D1 | D0 |
|------|--|----|----|----|----|----|----|----|
| Name | Relative Humidity or Temperature, Low Byte | | | | | | | |
| Type | Read | | | | | | | |

Reset Settings = 0000_0000

| Bit | Name | Function |
|-----|-------|---|
| 7:0 | DATAI | Data, Low Byte. Eight least significant bits of a temperature or humidity measurement. See Table 14 or Table 16 for the measurement format. |

Register 3. CONFIG

| Bit | D7 | D6 | D5 | D4 | D3 | D2 | D1 | D0 |
|------|----|----|------|------|----|----|------|-------|
| Name | | | FAST | TEMP | | | HEAT | START |
| Type | | | R/W | R/W | | | | R/W |

Reset Settings = 0000_0000

| Bit | Name | Function |
|-----|----------|---|
| 7:6 | Reserved | Reserved. Reads undefined. Always write as zero. |
| 5 | FAST | Fast Mode Enable. 0 = 35 ms (typical) 1 = 18 ms (typical) |
| 4 | TEMP | Temperature Enable. 0 = Relative humidity 1 = Temperature |
| 3:2 | Reserved | Reserved. Reads undefined. Always write as zero. |
| 1 | HEAT | Heater Enable. 0 = heater off 1 = heater on |
| 0 | START | Conversion Start. 0 = do not start a conversion 1 = start a conversion |

Register 17. ID

| Bit | D7 | D6 | D5 | D4 | D3 | D2 | D1 | D0 |
|------|-----|-----|-----|-----|-----|-----|-----|-----|
| Name | ID7 | ID6 | ID5 | ID4 | ID3 | ID2 | ID1 | ID0 |
| Type | R | R | R | R | R | R | R | R |

Reset Settings = 0101_0000

| Bit | Name | Function |
|-----|------|---|
| 7:0 | ID | Identification. See section "5.1.5. Device Identification". |

8. Pin Descriptions: Si7005

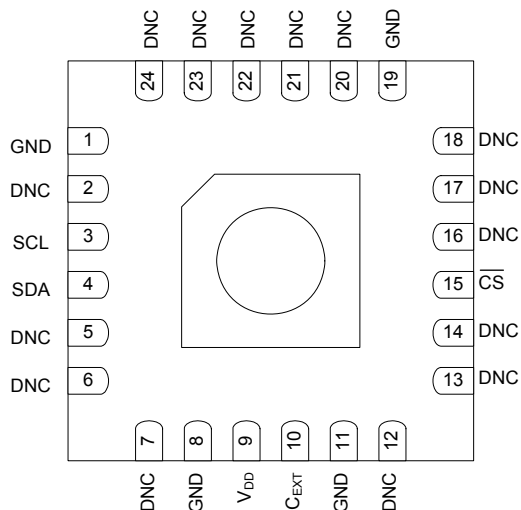

Table 25. Pin Descriptions

| Pin # | Pin Name | Pin Type* | Description |
|-----------------------------|------------------------|-----------|---|
| 1, 8, 11, 19 | GND | G | Ground. |
| 2, 5–7, 12–14, 16–18, 20–24 | DNC | | Do Not Connect. Do not connect any of these pins to supply, ground or any other signal. Internal pull-ups or pull-downs will prevent any of these pins from floating. |
| 3 | SCL | I | I²C Clock Signal. This pin is voltage-tolerant. See Table 2. |
| 4 | SDA | I/O | I²C Data Signal. This pin is voltage-tolerant. See Table 2. |
| 9 | V _{DD} | S | V_{DD} Power Supply (2.1 V ≤ V_{DD} ≤ 3.6 V). |
| 10 | C _{EXT} | I | Decoupling Input for Internal Circuitry. Connect a 4.7 μF capacitor between this pin and GND. |
| 15 | $\overline{\text{CS}}$ | I | Chip Select—Active Low Signal. |
| Epad | T _{GND} | G | Thermal Paddle. This pad is connected to GND internally. The pad can be connected to GND externally or it can be left open-circuit and used as a thermal input to the on-chip temperature sensor. |

***Note:** G = Ground, S = Power Supply, I = Digital Input, O = Digital Output, I/O = Input/Output.

9. Ordering Guide

Table 26. Si7005 Device Ordering Guide

| P/N | Description | Typ. Accuracy | | Pkg | Operating Range (°C) | Filter Cover | Packing Format |
|--------------------|---|---------------|-----|--------|----------------------|--------------|----------------|
| | | Temp | RH | | | | |
| Si7005-B-FM1 | Digital temperature/humidity sensor | ±0.5 °C | ±3% | QFN-24 | 0 to 70 °C | Y | Cut Tape |
| Si7005-B-GM1 | Digital temperature/humidity sensor | ±0.5 °C | ±3% | QFN-24 | -40 to +85 °C | Y | Cut Tape |
| Si7005-B-FMR | Digital temperature/humidity sensor | ±0.5 °C | ±3% | QFN-24 | 0 to 70 °C | N | Tape-and-reel |
| Si7005-B-FM1R | Digital temperature/humidity sensor | ±0.5 °C | ±3% | QFN-24 | 0 to 70 °C | Y | Tape-and-reel |
| Si7005-B-GMR | Digital temperature/humidity sensor | ±0.5 °C | ±3% | QFN-24 | -40 to +85 °C | N | Tape-and-reel |
| Si7005-B-GM1R | Digital temperature/humidity sensor | ±0.5 °C | ±3% | QFN-24 | -40 to +85 °C | Y | Tape-and-reel |
| Si7005-B-FM | Digital temperature/humidity sensor | ±0.5 °C | ±3% | QFN-24 | 0 to 70 °C | N | Cut Tape |
| Si7005-B-GM | Digital temperature/humidity sensor | ±0.5 °C | ±3% | QFN-24 | -40 to +85 °C | N | Cut Tape |
| Si7005USB-DONGLE | USB demonstration/evaluation board | | | | | | |
| Si7005-EVB | Si7005 daughter card with flex cable | | | | | | |
| Si7005EVB-UDP | Si7005 UDP plug-in daughter card | | | | | | |
| Si7005EVB-UDP-F960 | Low-power data logger demo/development kit with C8051F960 MCU | | | | | | |

10. Package Outline

10.1. 24-Pin QFN

Figure 11 illustrates the package details for the Si7005. Tables 27 and 28 list the values for the dimensions shown in the illustration. There are two package variants with slightly different height dimensions. The two package variants are otherwise interchangeable.

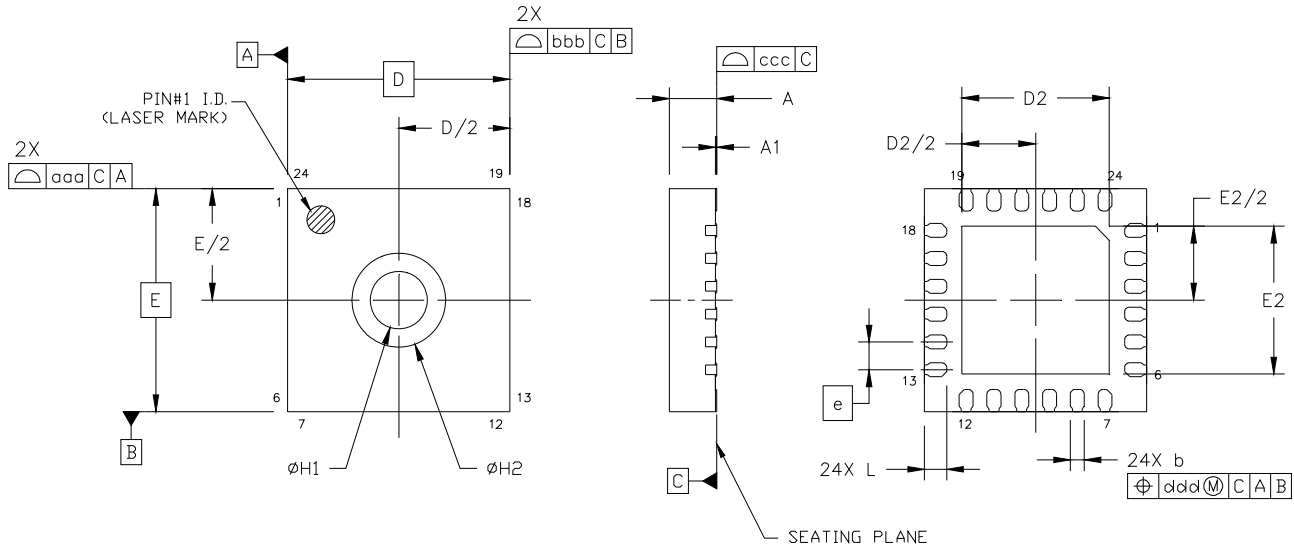

Figure 11. 24-Pin Quad Flat No Lead (QFN)

Table 27. 24-Pin Package Diagram Dimensions

| Dimension | Min | Nom | Max | Dimension | Min | Nom | Max |
|-----------|-----------|------|------|-----------|----------|------|------|
| A1 | 0.00 | 0.02 | 0.05 | H1 | 1.03 | 1.08 | 1.13 |
| b | 0.18 | 0.25 | 0.30 | H2 | 1.68 REF | | |
| D | 4.00 BSC. | | | L | 0.30 | 0.35 | 0.40 |
| D2 | 2.55 | 2.65 | 2.75 | aaa | — | — | 0.15 |
| e | 0.50 BSC. | | | bbb | — | — | 0.15 |
| E | 4.00 BSC. | | | ccc | — | — | 0.08 |
| E2 | 2.55 | 2.65 | 2.75 | ddd | — | — | 0.10 |

Notes:

1. Dimensioning and Tolerancing per ANSI Y14.5M-1994.
2. Recommended card reflow profile is per the JEDEC/IPC J-STD-020 specification for Small Body Components.

Table 28. Package Variants

| Dimension | Variant A | | | Variant B | | |
|-----------|-----------|------|------|-----------|------|------|
| | Min | Nom | Max | Min | Nom | Max |
| A | 0.80 | 0.90 | 1.00 | 0.70 | 0.75 | 0.80 |

Note: All Dimensions are in mm unless otherwise noted.

10.2. 24-Pin QFN with Protective Cover

Figure 12 illustrates the package details for the Si7005 with the optional protective cover. Tables 29 and 30 list the values for the dimensions shown in the illustration. There are two package variants with slightly different height dimensions. The two package variants are otherwise interchangeable.

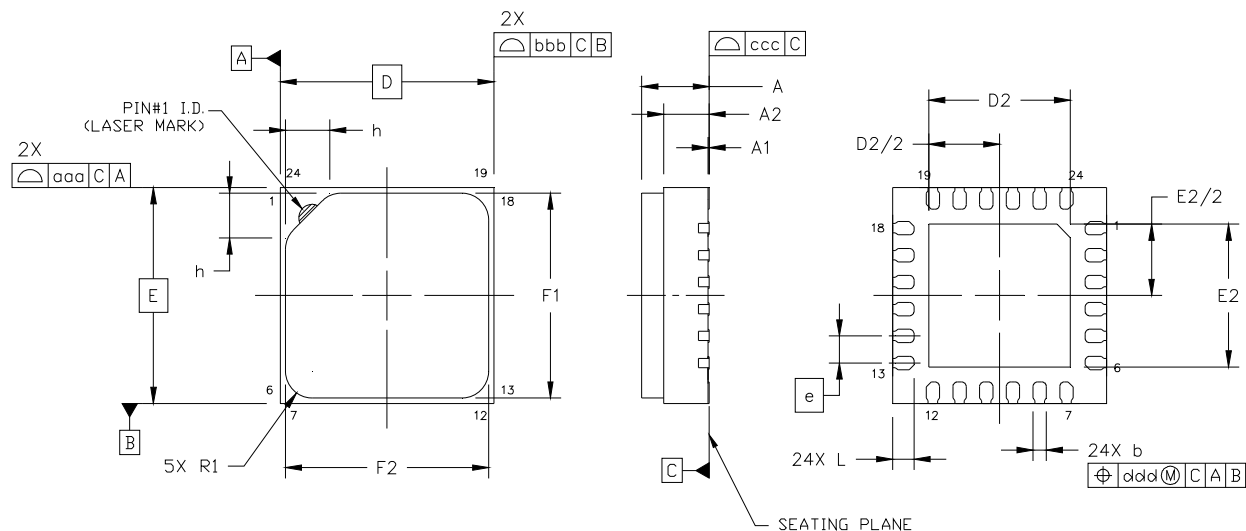

Figure 12. 24-Pin Quad Flat No Lead (QFN) With Protective Cover

Table 29. 24-Pin Package Diagram Dimensions

| Dimension | Min | Nom | Max |
|-----------|-----------|------|------|
| A1 | 0.00 | 0.02 | 0.05 |
| b | 0.18 | 0.25 | 0.30 |
| D | 4.00 BSC. | | |
| D2 | 2.55 | 2.65 | 2.75 |
| e | 0.50 BSC. | | |
| E | 4.00 BSC. | | |
| E2 | 2.55 | 2.65 | 2.75 |
| F1 | 3.60 | 3.75 | 3.90 |
| F2 | 3.60 | 3.75 | 3.90 |

| Dimension | Min | Nom | Max |
|-----------|------|------|------|
| h | 0.76 | 0.83 | 0.90 |
| L | 0.30 | 0.35 | 0.40 |
| R1 | 0.45 | 0.50 | 0.55 |
| aaa | — | — | 0.15 |
| bbb | — | — | 0.15 |
| ccc | — | — | 0.08 |
| ddd | — | — | 0.10 |

Notes:

1. Dimensioning and Tolerancing per ANSI Y14.5M-1994.
2. Recommended card reflow profile is per the JEDEC/IPC J-STD-020 specification for Small Body Components.

Table 30. Package Variants

| Dimension | Variant A | | | Variant B | | |
|-----------|-----------|------|------|-----------|------|------|
| | Min | Nom | Max | Min | Nom | Max |
| A | — | 1.27 | 1.41 | — | 1.07 | 1.21 |
| A2 | 0.80 | 0.90 | 1.00 | 0.70 | 0.75 | 0.80 |

Note: All Dimensions are in mm unless otherwise noted.

11. PCB Land Pattern and Solder Mask Design

Figure 13 illustrates the recommended PCB land pattern for use with the Si7005's 4x4 mm QFN package.

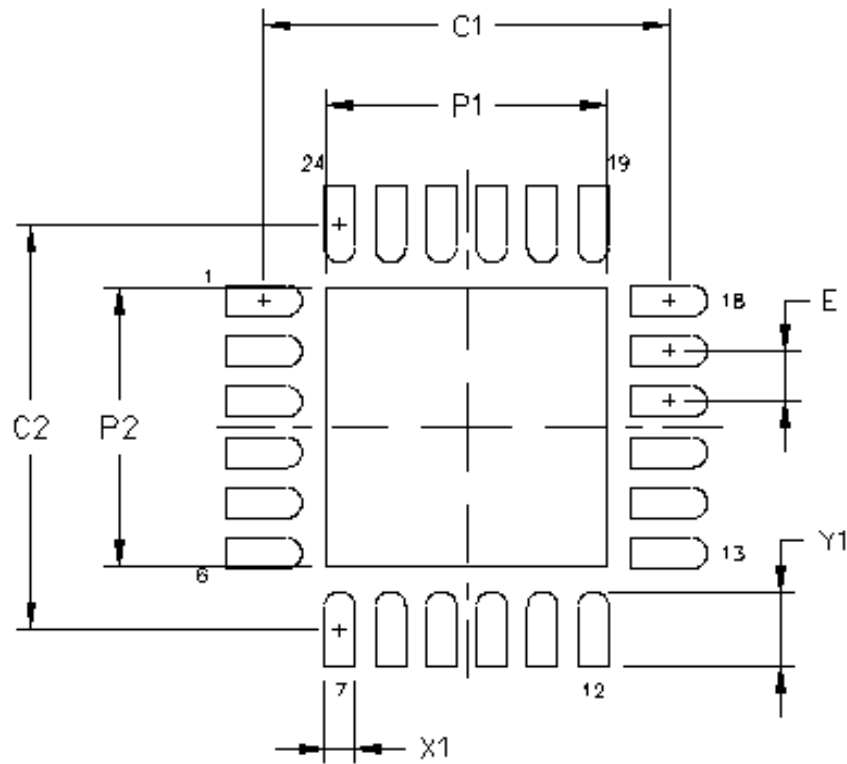

Figure 13. Typical QFN-24 PCB Land Pattern

Table 31. PCB Land Pattern Dimensions

| Symbol | mm |
|--------|------|
| C1 | 4.00 |
| C2 | 4.00 |
| E | 0.50 |
| P1 | 2.75 |
| P2 | 2.75 |
| X1 | 0.30 |
| Y1 | 0.75 |

Notes:**General**

1. All dimensions shown are at Maximum Material Condition (MMC). Least Material Condition (LMC) is calculated based on a Fabrication Allowance of 0.05 mm.
2. This Land Pattern Design is based on the IPC-7351 guidelines.

Solder Mask Design

3. All metal pads are to be non-solder mask defined (NSMD). Clearance between the solder mask and the metal pad is to be 60µm minimum, all the way around the pad.

Stencil Design

4. A stainless steel, laser-cut and electro-polished stencil with trapezoidal walls should be used to assure good solder paste release.
5. The stencil thickness should be 0.125 mm (5 mils).
6. The ratio of stencil aperture to land pad size should be 1:1 for all perimeter pins.
7. A 2x2 array of 0.95 mm square openings on 1.35 mm pitch should be used for the center ground pad.

Card Assembly

8. A No-Clean, Type-3 solder paste is recommended.
9. The recommended card reflow profile is per the JEDEC/IPC J-STD-020 specification for Small Body Components.

Si7005

12. Top Marking

12.1. Si7005 Top Marking

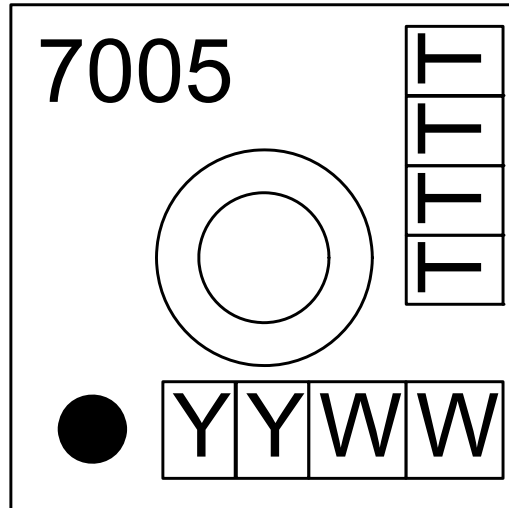

12.2. Top Marking Explanation

| Location | Marking | Explanation |
|-------------|---------|---|
| Upper Left | 7005 | Part Number |
| Upper Right | TTTT | Manufacturing trace code |
| Lower Left | (Dot) | Pin 1 Identifier |
| Lower Right | YYWW | Manufacturing date code YY = year WW = week |

Note: The top mark may not be visible if the optional protective cover is installed. If needed, the device can be identified by reading the identification register as explained in section "5.1.5. Device Identification".

13. Additional Reference Resources

- Si7005USB Dongle User's Guide
- Si7005EVB-UDP User's Guide
- AN607: Si70xx Humidity Sensor Designer's Guide

DOCUMENT CHANGE LIST

Revision 0.1 to Revision 0.2

- Updated Table 2, “General Specifications*,” on page 4.
- Updated Table 4, “Humidity Sensor,” on page 7.
 - New Note ¹.
- Added Table 6, “Thermal Characteristics,” on page 9.
- Updated Table 7, “Absolute Maximum Ratings^{1,2},” on page 9.
 - Updated max value for “Voltage on SDA or SCL pin with respect to GND” parameter.
- Updated Figure 2 on page 7.
- Updated Figure 3 on page 8.
- Updated “2.1.1. Steps to Perform Relative Humidity Measurement” on page 9.
- Updated Table 12, “14-Bit Temperature Result Available in Registers 1 and 2,” on page 10.
 - Revised title.
- Added “2.1.6. RSVD” on page 11.
- Updated “2.2. I2C Operation” on page 12.
- Updated Table 22, “I2C Read Sequence for a Single Register,” on page 24.
- Updated Table 23, “I2C Read Sequence for RH or Temperature Conversion Result,” on page 24.

Revision 0.2 to Revision 0.9

- Updated Features/Applications/Description
- Added pinout drawing to front page
- Updated Electrical Specifications
- Clarified voltage tolerance of \overline{CS} , SDA, and SCL pins
- Updated Typical Application Circuits and BOMs
- Updated and expanded Functional Description
- Updated Host Interface
- Updated register descriptions
- Added drawing and photo of device with cover
- Updated and expanded Ordering Guide
- Expanded Additional Reference Resources

Revision 0.9 to Revision 1.0

- Updated and expanded General Specification Table 2
- Updated and expanded General Specification Table 3
- Updated Figure 1.
- Updated Figure 2.
- Updated Bill of Materials

- Added Linearization Coefficients Table 10,11
- Updated Host Interface
- Updated I²C Operation
- Amended Connection Diagram
- Amended Ordering Guide
- Expanded Additional Reference Resources

Revision 1.0 to Revision 1.1

- Updated Figures 2 and 3.
 - Clarified RH and temperature accuracy graphs.
- Updated Figure 7.
 - Replaced with black and white version.
- Updated “4.7 Soldering” to “4.7. PCB Assembly”.
- Updated Table 19, “Device ID Revision Values,” on page 22.
 - Corrected title.

Revision 1.1 to Revision 1.2

- Updated Table 4, “Humidity Sensor,” on page 7.
 - Updated typical response time.
- Updated Table 7, “Absolute Maximum Ratings^{1,2},” on page 9.
 - Added ESD tolerance specs.

Revision 1.2 to Revision 1.3

- Added nominal values to Dimension A in Table 30

Revision 1.3 to Revision 1.4

- Minor modification to description and dimensions of protective cover due to the addition of a second cover supplier.

Revision 1.4 to Revision 1.5

- Changed packing format from tube to cut tape for all non-tape & reel part numbers without protective filter covers.

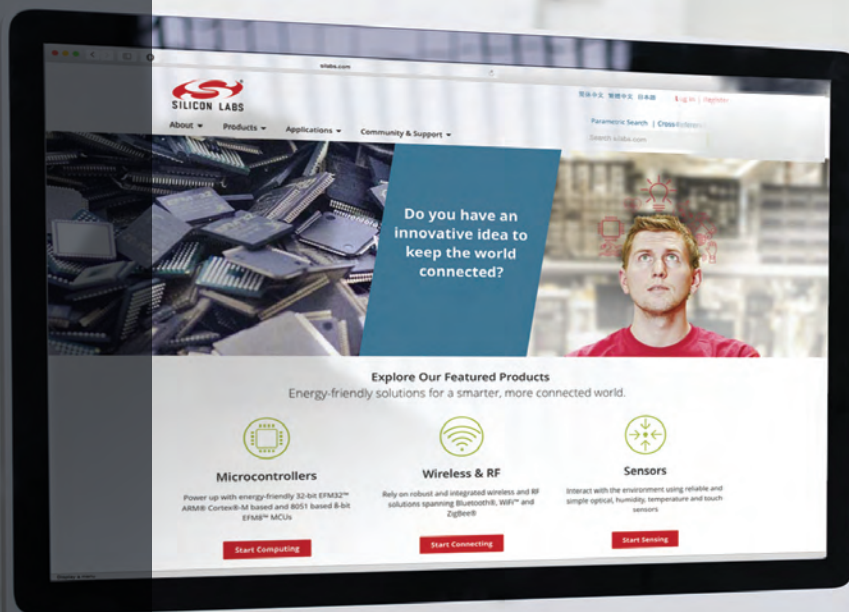

Smart.
Connected.
Energy-Friendly



Products
www.silabs.com/products

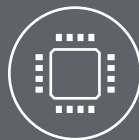

Quality
www.silabs.com/quality



Support and Community
community.silabs.com

Disclaimer

Silicon Laboratories intends to provide customers with the latest, accurate, and in-depth documentation of all peripherals and modules available for system and software implementers using or intending to use the Silicon Laboratories products. Characterization data, available modules and peripherals, memory sizes and memory addresses refer to each specific device, and "Typical" parameters provided can and do vary in different applications. Application examples described herein are for illustrative purposes only. Silicon Laboratories reserves the right to make changes without further notice and limitation to product information, specifications, and descriptions herein, and does not give warranties as to the accuracy or completeness of the included information. Silicon Laboratories shall have no liability for the consequences of use of the information supplied herein. This document does not imply or express copyright licenses granted hereunder to design or fabricate any integrated circuits. The products must not be used within any Life Support System without the specific written consent of Silicon Laboratories. A "Life Support System" is any product or system intended to support or sustain life and/or health, which, if it fails, can be reasonably expected to result in significant personal injury or death. Silicon Laboratories products are generally not intended for military applications. Silicon Laboratories products shall under no circumstances be used in weapons of mass destruction including (but not limited to) nuclear, biological or chemical weapons, or missiles capable of delivering such weapons.

Trademark Information

Silicon Laboratories Inc., Silicon Laboratories, Silicon Labs, SiLabs and the Silicon Labs logo, CMEMS®, EFM, EFM32, EFR, Energy Micro, Energy Micro logo and combinations thereof, "the world's most energy friendly microcontrollers", Ember®, EZLink®, EZMac®, EZRadio®, EZRadioPRO®, DSPLL®, ISOmodem®, Precision32®, ProSLIC®, SiPHY®, USBXpress® and others are trademarks or registered trademarks of Silicon Laboratories Inc. ARM, CORTEX, Cortex-M3 and THUMB are trademarks or registered trademarks of ARM Holdings. Keil is a registered trademark of ARM Limited. All other products or brand names mentioned herein are trademarks of their respective holders.



Silicon Laboratories Inc.
400 West Cesar Chavez
Austin, TX 78701
USA

<http://www.silabs.com>

Looking for pricing, stock, or lifecycle information?

Click below to explore more details on WIN SOURCE:

 [View SI7005-B-FM1R on WIN SOURCE](#)

 [Silicon Labs](#) Information

Optimize Your Supply Chain with WIN SOURCE Solutions

-  Global Sourcing Solution
-  Obsolete Management
-  Cost Control Management
-  Shortage Management
-  Alternative Solution
-  Excess Inventory Management