



**THE DATASHEET OF  
THVD1449DR**



# THVD14x9x 3-V to 5.5-V RS-485 Transceivers With 4-kV Surge Protection and 1.8-V VIO Capability

## 1 Features

- Meets or exceeds the requirements of the TIA/EIA-485A standard
- 3-V to 5.5-V Supply Voltage
- $V_{IO}$  Support from 1.65-V to  $V_{CC}$  supply level (THVD1439V, THVD1449V)
- Bus I/O protection
  - $\pm 4$ -kV IEC 61000-4-5 1.2/50- $\mu$ s surge
  - $\pm 15$ -kV IEC 61000-4-2 Contact discharge
  - $\pm 15$ -kV IEC 61000-4-2 Air-gap discharge
  - $\pm 4$ -kV IEC 61000-4-4 Electrical fast transient
  - $\pm 15$ -kV HBM ESD
  - $\pm 15$ -V DC bus fault
- Available in two speed grades
  - THVD1439, THVD1439V: 250 kbps
  - THVD1449, THVD1449V: 12 Mbps
- Extended ambient temperature range:  $-40^{\circ}\text{C}$  to  $125^{\circ}\text{C}$
- Extended operational common-mode range:  $\pm 12$  V
- Large receiver hysteresis for noise rejection
- Low Power Consumption
  - Standby supply current:  $< 3$   $\mu\text{A}$
  - Current during operation:  $< 5$  mA
- Glitch-free power-up/down for hot plug-in capability
- Open, short, and idle bus failsafe
- 1/8 Unit load (up to 256 bus nodes)
- Industry standard 8-pin SOIC for drop-in compatibility

## 2 Applications

- [Wireless infrastructure](#)
- [Factory automation](#)
- [Motor drives](#)
- [Building automation](#)
- [HVAC](#)
- [Grid infrastructure](#)

## 3 Description

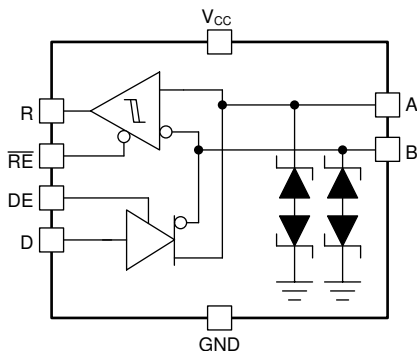
THVD14x9(V) devices are half-duplex RS-485 transceivers with integrated surge protection. Surge protection is achieved by integrating transient voltage suppressor (TVS) diodes in the standard 8-pin SOIC (D) package. This feature increases the reliability by providing better immunity to noise transients coupled to the data cable which eliminates the need for external protection components.

THVD1439 and THVD1449 operate from a single 3.3-V or 5-V supply. The THVD1439V and THVD1449V devices support an additional  $V_{IO}$  supply to operate the IOs from as low as 1.65 V supply level. The devices in this family feature a wide common-mode voltage range making them suitable for multi-point applications over long cable runs.

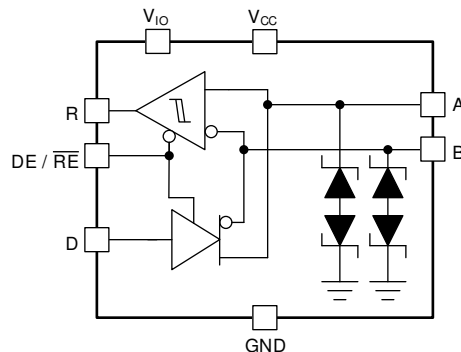
### Device Information

PART NUMBER	PACKAGE <sup>(1)</sup>	BODY SIZE (NOM)
THVD1439	SOIC (8)	4.90 mm $\times$ 3.91 mm
THVD1439V		
THVD1449		
THVD1449V		

- (1) For all available devices, see the orderable addendum at the end of the data sheet.



THVD14x9 Block Diagram



THVD14x9V Block Diagram



## Table of Contents

<b>1 Features</b> .....	<b>1</b>	<b>8 Detailed Description</b> .....	<b>14</b>
<b>2 Applications</b> .....	<b>1</b>	8.1 Overview.....	14
<b>3 Description</b> .....	<b>1</b>	8.2 Functional Block Diagrams.....	14
<b>4 Revision History</b> .....	<b>2</b>	8.3 Feature Description.....	14
<b>5 Pin Configuration and Functions</b> .....	<b>4</b>	8.4 Device Functional Modes.....	18
<b>6 Specifications</b> .....	<b>5</b>	<b>9 Application and Implementation</b> .....	<b>19</b>
6.1 Absolute Maximum Ratings .....	5	9.1 <b>Application Information</b> .....	19
6.2 ESD Ratings .....	5	9.2 Typical Application.....	19
6.3 ESD Ratings, IEC .....	5	<b>10 Power Supply Recommendations</b> .....	<b>22</b>
6.4 Recommended Operating Conditions .....	6	<b>11 Layout</b> .....	<b>23</b>
6.5 Thermal Information .....	6	11.1 Layout Guidelines.....	23
6.6 Power Dissipation .....	6	11.2 Layout Example.....	23
6.7 Electrical Characteristics .....	7	<b>12 Device and Documentation Support</b> .....	<b>25</b>
6.8 Switching Characteristics (THVD1439, THVD1439V) .....	9	12.1 Device Support.....	25
6.9 Switching Characteristics (THVD1449, THVD1449V) .....	9	12.2 Receiving Notification of Documentation Updates..	25
6.10 Typical Characteristics.....	10	12.3 Support Resources.....	25
<b>7 Parameter Measurement Information</b> .....	<b>12</b>	12.4 Trademarks.....	25
		12.5 Electrostatic Discharge Caution.....	25
		12.6 Glossary.....	25

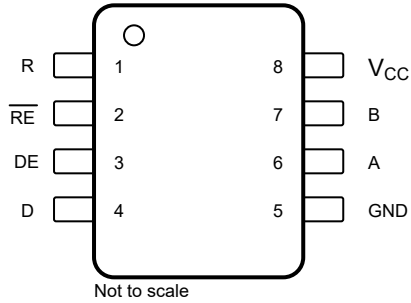
## 4 Revision History

Changes from Revision A (June 2021) to Revision B (September 2021)	Page
• Changed document status from <i>Advanced Information</i> to <i>Production</i> data .....	1

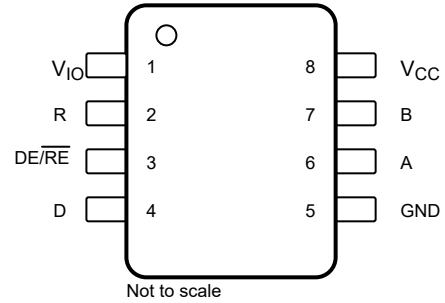
## Device Comparison Table

PART NUMBER	DUPLEX	ENABLES	V <sub>IO</sub>	SIGNALING RATE	NODES
THVD1439	Half	Separate DE and $\overline{RE}$	No	up to 250 kbps	256
THVD1439V		Combined DE / $\overline{RE}$	Yes		
THVD1449		Separate DE and $\overline{RE}$	No	up to 12 Mbps	
THVD1449V		Combined DE / $\overline{RE}$	Yes		

## 5 Pin Configuration and Functions



**Figure 5-1. THVD1439, THVD1449, 8-Pin (SOIC), Top View**



**Figure 5-2. THVD1439V, THVD1449V, 8-Pin (SOIC), Top View**

NAME	PIN		I/O	DESCRIPTION
	THVD1439, THVD1449	THVD1439 V, THVD1449V		
V <sub>IO</sub>	-	1	P	1.8-V to 5-V supply for R, D, and RE/DE
R	1	2	O	Receiver data output
RE	2	-	I	Receiver enable, active low (2 MΩ internal pull-up)
DE	3	-	I	Driver enable, active high
DE/RE	-	3	I	Driver enable (Active high), Receiver enable (Active Low). (2 MΩ internal pull-down)
D	4	4	I	Driver data input
GND	5	5	-	Device ground
A	6	6	I/O	Bus I/O port, A (complementary to B)
B	7	7	I/O	Bus I/O port, B (complementary to A)
V <sub>CC</sub>	8	8	P	3.3-V to 5-V supply for the device

## 6 Specifications

### 6.1 Absolute Maximum Ratings

over operating free-air temperature range (unless otherwise noted)<sup>(1)</sup>

		MIN	MAX	UNIT
Supply voltage	$V_{CC}$	-0.5	7	V
Logic supply voltage	$V_{IO}$	-0.5	$V_{CC}+0.2$	V
Bus voltage	Range at any bus pin (A or B)	-15	15	V
Input voltage	Range at any logic pin (R, D, DE, or $\overline{RE}$ ) THVD1439, THVD1449	-0.3	5.7	V
Input voltage	Range at any logic pin (R, D, DE, or $\overline{RE}$ ) THVD1439V, THVD1449V	-0.3	$V_{IO}+0.2$	V
Receiver output current	$I_O$	-24	24	mA
Storage temperature	$T_{slg}$	-65	150	°C

- (1) Stresses beyond those listed under *Absolute Maximum Ratings* may cause permanent damage to the device. These are stress ratings only, which do not imply functional operation of the device at these or any other conditions beyond those indicated under *Recommended Operating Conditions*. Exposure to absolute-maximum-rated conditions for extended periods may affect device reliability.

### 6.2 ESD Ratings

			VALUE	UNIT	
$V_{(ESD)}$	Electrostatic discharge	Human-body model (HBM), per ANSI/ESDA/ JEDEC JS-001 <sup>(1)</sup>	Bus terminals and GND	±15,000	V
			All pins except bus terminals and GND	±4,000	
		Charged-device model (CDM), per JEDEC specification JESD22-C102 <sup>(2)</sup>	±1,500		

- (1) JEDEC document JEP155 states that 500-V HBM allows safe manufacturing with a standard ESD control process.  
 (2) JEDEC document JEP157 states that 250-V CDM allows safe manufacturing with a standard ESD control process.

### 6.3 ESD Ratings, IEC

				VALUE	UNIT
$V_{(ESD)}$	Electrostatic discharge	Contact Discharge, per IEC 61000-4-2	Bus terminals	±15,000	V
		Air-Gap Discharge, per IEC 61000-4-2		±15,000	
$V_{(EFT)}$	Electrical fast transient	Per IEC 61000-4-4	Bus terminals	±4,000	V
$V_{(surge)}$	Surge	Per IEC 61000-4-5, 1.2/50 $\mu$ s	Bus terminals	±4,000	V

## 6.4 Recommended Operating Conditions

over operating free-air temperature range (unless otherwise noted)

		MIN	NOM	MAX	UNIT
V <sub>CC</sub>	Supply voltage	3		5.5	V
V <sub>IO</sub>	IO Supply Voltage (V Variant)	1.65		V <sub>CC</sub>	V
V <sub>I</sub>	Input voltage on logic pins (R, D, DE, or RE)	THVD1439, THVD1449		5.5	V
V <sub>I</sub>		THVD1439V, THVD1449V		V <sub>IO</sub>	V
V <sub>I</sub>	Input voltage at bus pins (A or B) <sup>(1)</sup>	-12		12	V
V <sub>IH</sub>	High-level input voltage (R, D, DE, or RE)	0.67 * V <sub>IO</sub>		V <sub>IO</sub>	V
V <sub>IL</sub>	Low-level input voltage (R, D, DE, or RE)	0		0.33 * V <sub>IO</sub>	V
V <sub>IH</sub>	High-level input voltage (R, D, DE, or RE)	THVD1439V, THVD1449V		5.5	V
V <sub>IL</sub>	Low-level input voltage (R, D, DE, or RE)	THVD1439, THVD1449		0.8	V
V <sub>ID</sub>	Differential input voltage	-12		12	V
I <sub>O</sub>	Output current, driver	-60		60	mA
I <sub>OR</sub>	Output current, receiver	-8		8	mA
R <sub>L</sub>	Differential load resistance	54			Ω
1/t <sub>UI</sub>	Signaling rate	THVD1439, THVD1439V		250	kbps
		THVD1449, THVD1449V		12	Mbps
T <sub>A</sub>	Operating ambient temperature	-40		125	°C

(1) The algebraic convention, in which the least positive (most negative) limit is designated as minimum is used in this data sheet.

## 6.5 Thermal Information

THERMAL METRIC <sup>(1)</sup>		THVD1439 THVD1439V THVD1449 THVD1449V	UNIT
		D (SOIC)	
		8 PINS	
R <sub>θJA</sub>	Junction-to-ambient thermal resistance	120.7	°C/W
R <sub>θJC(top)</sub>	Junction-to-case (top) thermal resistance	50.3	°C/W
R <sub>θJB</sub>	Junction-to-board thermal resistance	62.8	°C/W
Ψ <sub>JT</sub>	Junction-to-top characterization parameter	7.5	°C/W
Ψ <sub>JB</sub>	Junction-to-board characterization parameter	62.2	°C/W
R <sub>θJC(bot)</sub>	Junction-to-case (bottom) thermal resistance	N/A	°C/W

(1) For more information about traditional and new thermal metrics, see the [Semiconductor and IC Package Thermal Metrics](#) application report.

## 6.6 Power Dissipation

over operating free-air temperature range (unless otherwise noted)

PARAMETER		TEST CONDITIONS		VALUE	UNIT	
PD	Driver and receiver enabled, V <sub>CC</sub> = 5.5 V, T <sub>A</sub> = 125 °C, 50% duty cycle square wave at signaling rate	Unterminated R <sub>L</sub> = 300 Ω, C <sub>L</sub> = 50 pF (driver)	THVD1439	250 kbps	160	mW
			THVD1449	12 Mbps	290	
		RS-422 load R <sub>L</sub> = 100 Ω, C <sub>L</sub> = 50 pF (driver)	THVD1439	250 kbps	190	mW
			THVD1449	12 Mbps	290	
		RS-485 load R <sub>L</sub> = 54 Ω, C <sub>L</sub> = 50 pF (driver)	THVD1439	250 kbps	250	mW
			THVD1449	12 Mbps	320	

## 6.7 Electrical Characteristics

over operating free-air temperature range (unless otherwise noted)

PARAMETER		TEST CONDITIONS		MIN	TYP	MAX	UNIT
<b>Driver</b>							
V <sub>OD</sub>	Driver differential output voltage magnitude	R <sub>L</sub> = 60 Ω, -12 V ≤ V <sub>test</sub> ≤ 12 V (See Figure 7-1)		1.5	2		V
		R <sub>L</sub> = 60 Ω, -12 V ≤ V <sub>test</sub> ≤ 12 V, 4.5 V ≤ V <sub>CC</sub> ≤ 5.5 V (See Figure 7-1)		2.1			V
		R <sub>L</sub> = 100 Ω (See Figure 7-2)		2	2.5		V
		R <sub>L</sub> = 54 Ω (See Figure 7-2)		1.5	2		V
Δ V <sub>OD</sub>	Change in differential output voltage	R <sub>L</sub> = 54 Ω (See Figure 7-2)		-50		50	mV
V <sub>OC</sub>	Common-mode output voltage	R <sub>L</sub> = 54 Ω (See Figure 7-2)		1	V <sub>CC</sub> / 2	3	V
ΔV <sub>OC(SS)</sub>	Change in steady-state common-mode output voltage	R <sub>L</sub> = 54 Ω (See Figure 7-2)		-50		50	mV
I <sub>OS</sub>	Short-circuit output current	DE = V <sub>CC</sub> , -12 V ≤ V <sub>O</sub> ≤ 12 V		-250		250	mA
<b>Receiver</b>							
I <sub>I</sub>	Bus input current	DE = 0 V, V <sub>CC</sub> = 0 V or 5.5 V	V <sub>I</sub> = 12 V		75	135	μA
			V <sub>I</sub> = -7 V	-100	-40		
			V <sub>I</sub> = -12 V	-135	-75		
V <sub>TH+</sub>	Positive-going input threshold voltage <sup>(1)</sup>	Over common-mode range of ±12 V		40	125	200	mV
V <sub>TH-</sub>	Negative-going input threshold voltage <sup>(1)</sup>			-200	-125	-40	mV
V <sub>HYS</sub>	Input hysteresis				250		mV
V <sub>TH_FSH</sub>	Input fail-safe threshold			-40		40	mV
V <sub>OH</sub>	Output high voltage	THVD1439V, THVD1449V	I <sub>OH</sub> = -4 mA; V <sub>IO</sub> = 1.65 V - 3 V	V <sub>IO</sub> - 0.4	V <sub>IO</sub> - 0.2		V
			I <sub>OH</sub> = -8 mA; V <sub>IO</sub> = 3 V - 5.5 V				
		THVD1439, THVD1449	I <sub>OH</sub> = -8 mA	V <sub>CC</sub> - 0.4	V <sub>CC</sub> - 0.2		
V <sub>OL</sub>	Output low voltage	THVD1439V, THVD1449V	I <sub>OL</sub> = 8 mA; V <sub>IO</sub> = 3 V - 5.5 V	0.2	0.4		V
			I <sub>OL</sub> = 4 mA; V <sub>IO</sub> = 1.65 V - 3 V				
		THVD1439, THVD1449	I <sub>OL</sub> = 8 mA				
I <sub>OZ</sub>	Output high-impedance current	V <sub>O</sub> = 0 V or V <sub>CC</sub> , RE = V <sub>CC</sub>		-1		1	μA
<b>Logic</b>							
I <sub>IN</sub>	Input current (D, DE, RE)	THVD1439V, THVD1449V	3 V ≤ V <sub>CC</sub> ≤ 5.5 V, 1.65 V ≤ V <sub>IO</sub> ≤ V <sub>CC</sub> V, 0 V ≤ V <sub>IN</sub> ≤ V <sub>IO</sub>	-5		5	μA
		THVD1439, THVD1449	3 V ≤ V <sub>CC</sub> ≤ 5.5 V, 0 V ≤ V <sub>IN</sub> ≤ V <sub>CC</sub>	-5		5	μA
<b>Thermal Protection</b>							
T <sub>SHDN</sub>	Thermal shutdown threshold	Temperature rising		150	170		°C
T <sub>HYS</sub>	Thermal shutdown hysteresis				10		°C

## 6.7 Electrical Characteristics (continued)

over operating free-air temperature range (unless otherwise noted)

PARAMETER		TEST CONDITIONS		MIN	TYP	MAX	UNIT	
<b>Supply</b>								
$I_{CC}$	Supply current (quiescent)	$V_{CC}=3.6\text{ V}$	Driver and receiver enabled (THVD1439, THVD1449)	$\overline{RE} = 0\text{ V}$ , $DE = V_{CC}$ , No load		3	4	mA
			Driver enabled, receiver disabled	$\overline{RE} = V_{CC}$ , $DE = V_{CC}$ , No load		2	3	mA
			Driver disabled, receiver enabled	$\overline{RE} = 0\text{ V}$ , $DE = 0\text{ V}$ , No load		1.7	2.2	mA
			Driver and receiver disabled (THVD1439, THVD1449)	$\overline{RE} = V_{CC}$ , $DE = 0\text{ V}$ , $D = \text{open}$ , No load		0.1	1.5	$\mu\text{A}$
	Supply current (quiescent)	$V_{CC}=5.5\text{ V}$	Driver and receiver enabled (THVD1439, THVD1449)	$\overline{RE} = 0\text{ V}$ , $DE = V_{CC}$ , No load		3.5	5	mA
			Driver enabled, receiver disabled	$\overline{RE} = V_{CC}$ , $DE = V_{CC}$ , No load		2.5	3.8	mA
			Driver disabled, receiver enabled	$\overline{RE} = 0\text{ V}$ , $DE = 0\text{ V}$ , No load		1.8	2.4	mA
			Driver and receiver disabled (THVD1439, THVD1449)	$\overline{RE} = V_{CC}$ , $DE = 0\text{ V}$ , $D = \text{open}$ , No load		0.2	3	$\mu\text{A}$
$I_{IO}$	VIO supply current (quiescent)	THVD1439V, THVD1449V	Driver Enabled	$DE/\overline{RE}=V_{IO}$ , $D=\text{open}$ , No load			5	$\mu\text{A}$
			Receiver enabled	$DE/\overline{RE}=0\text{ V}$ , $D=\text{open}$ , No load				5

(1) Under any specific conditions,  $V_{TH+}$  is assured to be at least  $V_{HYS}$  higher than  $V_{TH-}$ .

## 6.8 Switching Characteristics (THVD1439, THVD1439V)

250-kbps devices (THVD1439, 39V), over recommended operating conditions. All typical values are at 25 °C.

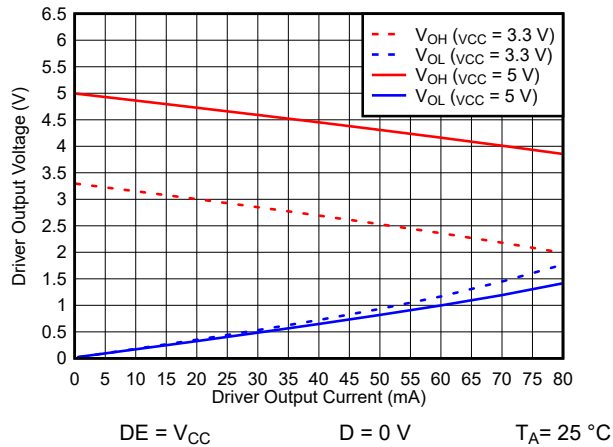
PARAMETER	TEST CONDITIONS	MIN	TYP	MAX	UNIT		
<b>Driver</b>							
$t_r, t_f$	Differential output rise/fall time	300	570	1200	ns		
$t_{PHL}, t_{PLH}$	Propagation delay	$R_L = 54 \Omega, C_L = 50 \text{ pF}$	See <a href="#">Figure 7-3</a>	450	650	ns	
$t_{SK(P)}$	Pulse skew, $ t_{PHL} - t_{PLH} $			50	ns		
$t_{PHZ}, t_{PLZ}$	Disable time		25	125	ns		
$t_{PZH}, t_{PZL}$	Enable time	$\overline{RE} = 0 \text{ V}$	See <a href="#">Figure 7-4</a> and <a href="#">Figure 7-5</a>	240	600	ns	
		$\overline{RE} = V_{CC}$		2	4	$\mu\text{s}$	
$t_{SHDN}$	Pulse width (logic low) on DE pin to initiate device shutdown	$\overline{RE} = V_{CC}$		300	ns		
<b>Receiver</b>							
$t_r, t_f$	Differential output rise/fall time	$C_L = 15 \text{ pF}$	See <a href="#">Figure 7-6</a>	9	25	ns	
$t_{PHL}, t_{PLH}$	Propagation delay			70	110	ns	
$t_{SK(P)}$	Pulse skew, $ t_{PHL} - t_{PLH} $			7	ns		
$t_{PHZ}, t_{PLZ}$	Disable time		22	60	ns		
$t_{PZH(1)}, t_{PZL(1)}, t_{PZH(2)}, t_{PZL(2)}$	Enable time	$DE = V_{CC}$	See <a href="#">Figure 7-7</a>	120	185	ns	
		$DE = 0 \text{ V}$		4	10	$\mu\text{s}$	
$t_{D(OFS)}$	Delay to enter fail-safe operation	$C_L = 15 \text{ pF}$	See <a href="#">Figure 7-9</a>	14	20	36	$\mu\text{s}$
$t_{D(FSO)}$	Delay to exit fail-safe operation			25	40	66	ns
$t_{SHDN}$	$\overline{RE}$ pulse width to initiate device shutdown	$DE = 0 \text{ V}$		300	ns		

## 6.9 Switching Characteristics (THVD1449, THVD1449V)

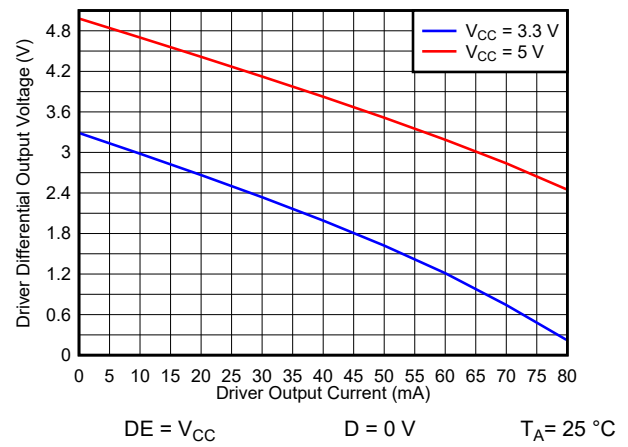
12-Mbps devices (THVD1449, 49V), over recommended operating conditions. All typical values are at 25 °C.

PARAMETER	TEST CONDITIONS	MIN	TYP	MAX	UNIT		
<b>Driver</b>							
$t_r, t_f$	Differential output rise/fall time	2	12	25	ns		
$t_{PHL}, t_{PLH}$	Propagation delay	$R_L = 54 \Omega, C_L = 50 \text{ pF}$	See <a href="#">Figure 7-3</a>	7	10	25	ns
$t_{SK(P)}$	Pulse skew, $ t_{PHL} - t_{PLH} $			3.5	ns		
$t_{PHZ}, t_{PLZ}$	Disable time		25	75	ns		
$t_{PZH}, t_{PZL}$	Enable time	$\overline{RE} = 0 \text{ V}$	See <a href="#">Figure 7-4</a> and <a href="#">Figure 7-5</a>	18	65	ns	
		$\overline{RE} = V_{CC}$		2	4	$\mu\text{s}$	
$t_{SHDN}$	Pulse width (logic low) on DE pin to initiate device shutdown	$\overline{RE} = V_{CC}$		300	ns		
<b>Receiver</b>							
$t_r, t_f$	Differential output rise/fall time	$C_L = 15 \text{ pF}$	See <a href="#">Figure 7-6</a>	3	10	ns	
$t_{PHL}, t_{PLH}$	Propagation delay			30	60	110	ns
$t_{SK(P)}$	Pulse skew, $ t_{PHL} - t_{PLH} $			4	ns		
$t_{PHZ}, t_{PLZ}$	Disable time		10	30	ns		
$t_{PZH(1)}, t_{PZL(1)}, t_{PZH(2)}, t_{PZL(2)}$	Enable time	$DE = V_{CC}$	See <a href="#">Figure 7-7</a>	90	130	ns	
		$DE = 0 \text{ V}$		4	10	$\mu\text{s}$	
$t_{D(OFS)}$	Delay to enter fail-safe operation	$C_L = 15 \text{ pF}$	See <a href="#">Figure 7-9</a>	14	20	36	$\mu\text{s}$
$t_{D(FSO)}$	Delay to exit fail-safe operation			25	35	55	ns
$t_{SHDN}$	Pulse width (logic high) on $\overline{RE}$ pin to initiate device shutdown	$DE = 0 \text{ V}$		300	ns		

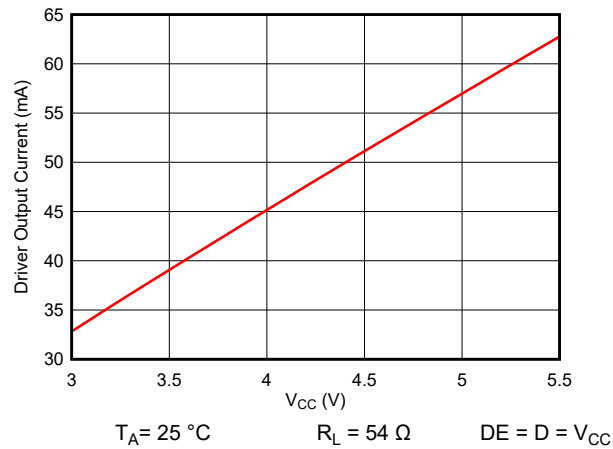
## 6.10 Typical Characteristics



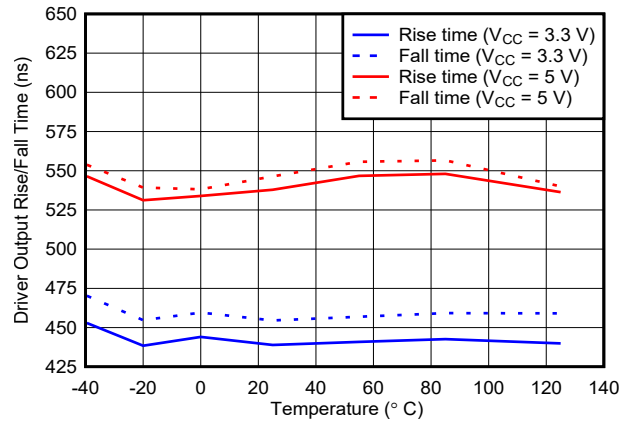
**Figure 6-1. Driver Output Voltage vs Driver Output Current**



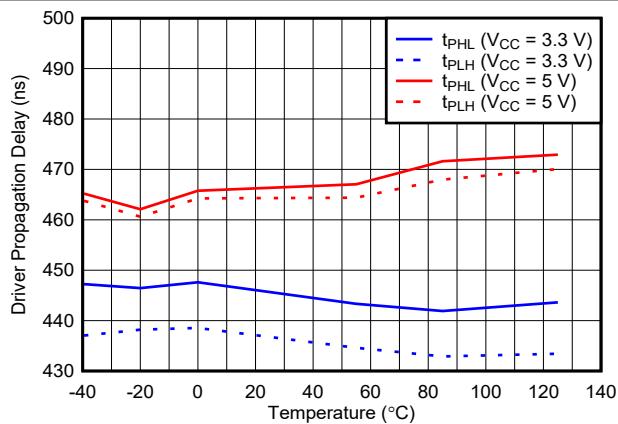
**Figure 6-2. Driver Differential Output Voltage vs Driver Output Current**



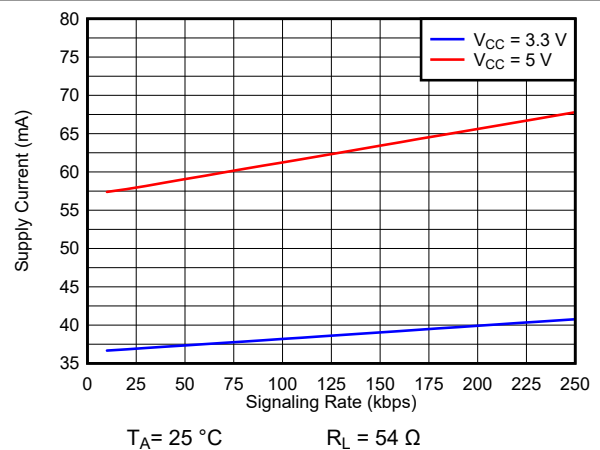
**Figure 6-3. Driver Output Current vs Supply Voltage**



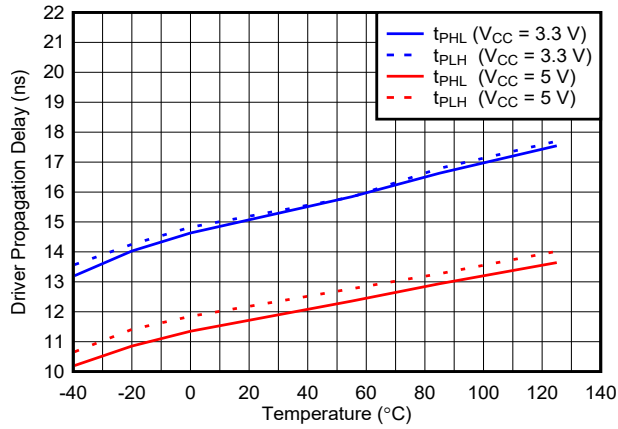
**Figure 6-4. THVD1439, THVD1439V Driver Rise or Fall Time vs Temperature**



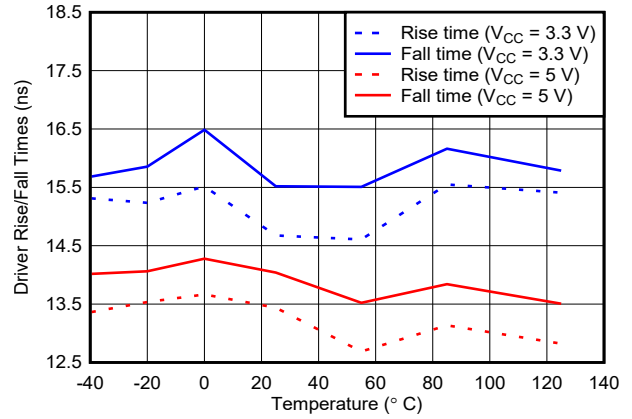
**Figure 6-5. THVD1439, THVD1439V Driver Propagation Delay vs Temperature**



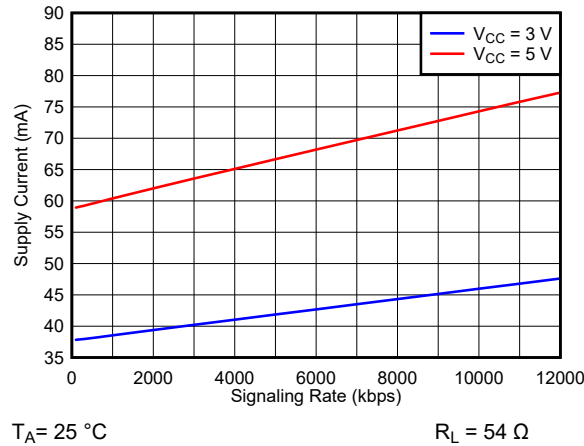
**Figure 6-6. THVD1439, THVD1439V Supply Current vs Signal Rate**



**Figure 6-7. THVD1449, THVD1449V Driver Propagation Delay vs Temperature**

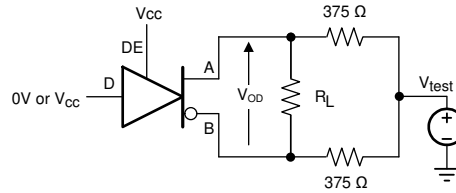


**Figure 6-8. THVD1449, THVD1449V Driver Rise or Fall Time vs Temperature**

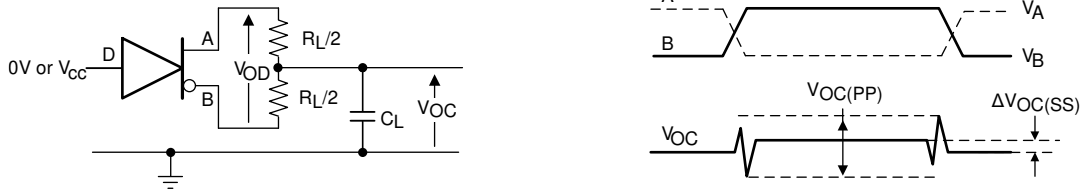


**Figure 6-9. THVD1449, THVD1449V Supply Current vs Signal Rate**

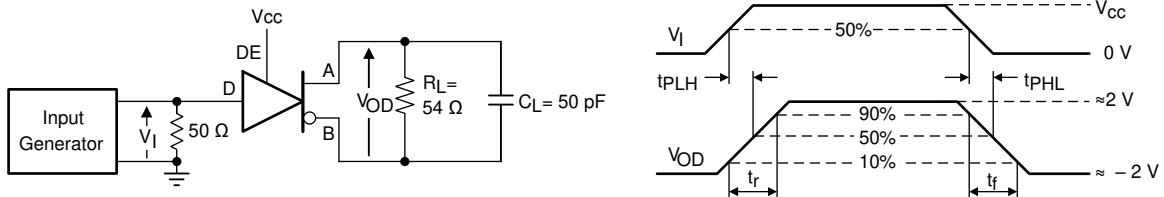
## 7 Parameter Measurement Information



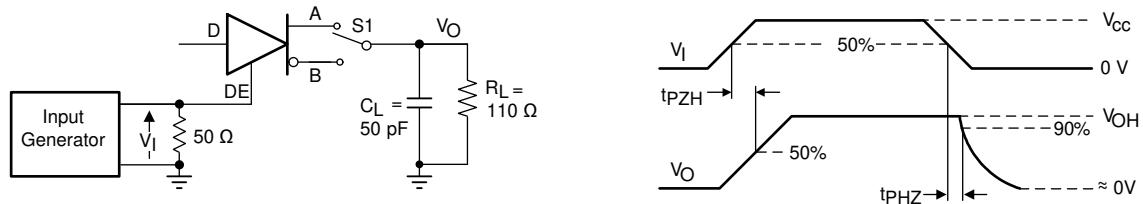
**Figure 7-1. Measurement of Driver Differential Output Voltage With Common-Mode Load**



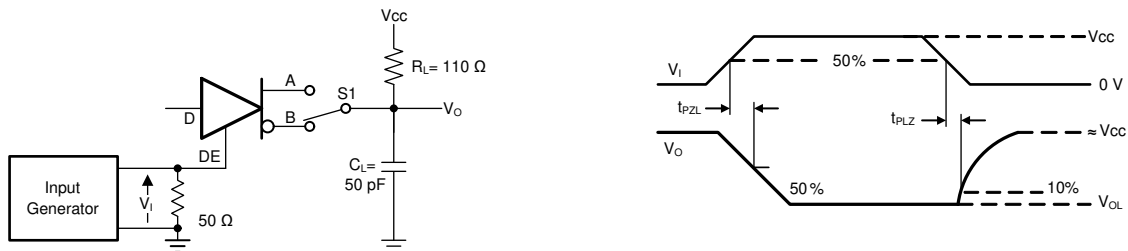
**Figure 7-2. Measurement of Driver Differential and Common-Mode Output With RS-485 Load**



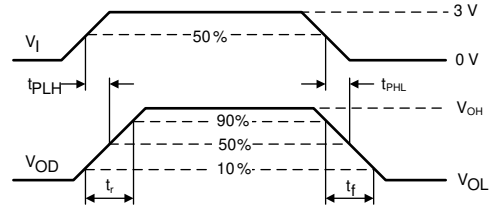
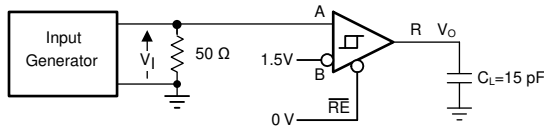
**Figure 7-3. Measurement of Driver Differential Output Rise and Fall Times and Propagation Delays**



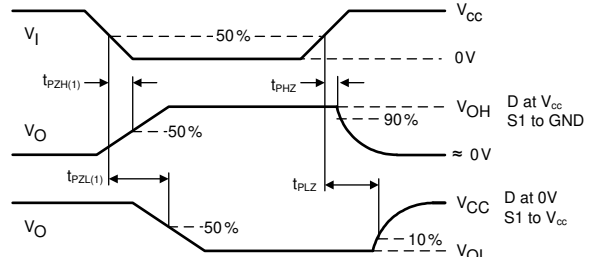
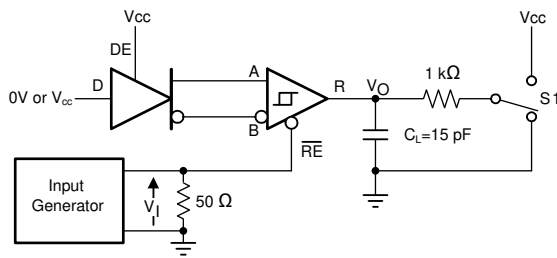
**Figure 7-4. Measurement of Driver Enable and Disable Times With Active High Output and Pull-Down Load**



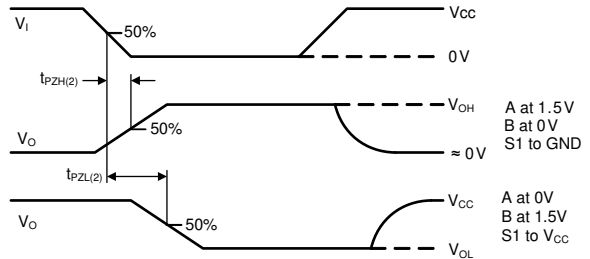
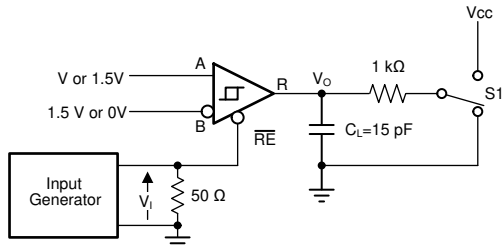
**Figure 7-5. Measurement of Driver Enable and Disable Times With Active Low Output and Pull-up Load**



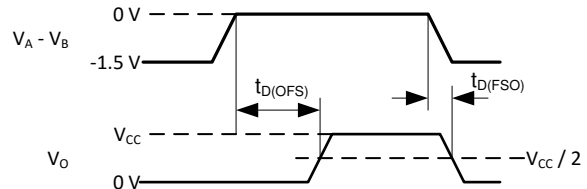
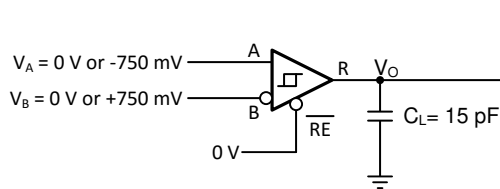
**Figure 7-6. Measurement of Receiver Output Rise and Fall Times and Propagation Delays**



**Figure 7-7. Measurement of Receiver Enable/Disable Times With Driver Enabled**



**Figure 7-8. Measurement of Receiver Enable Times With Driver Disabled**



Copyright © 2017, Texas Instruments Incorporated

**Figure 7-9. Fail-Safe Delay Measurements**

## 8 Detailed Description

### 8.1 Overview

THVD14x9(V) devices are surge-protected, half duplex RS-485 transceivers available in two speed grades suitable for data transmission up to 250 kbps and 12 Mbps respectively. Surge protection is achieved by integrating transient voltage suppressor (TVS) diodes in the standard 8-pin SOIC (D) package.

THVD1439 and THVD1449 devices have active-high driver enables and active-low receiver enables. A standby current of less than 1.5  $\mu\text{A}$  ( $V_{CC} = 3.6\text{ V}$ ) can be achieved by disabling both driver and receiver. THVD1439V and THVD1449V have a single enable/disable pin that either enables the driver or the receiver at a time.

### 8.2 Functional Block Diagrams

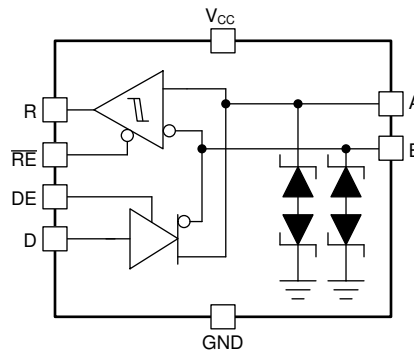


Figure 8-1. THVD1439 and THVD1449 Block Diagram

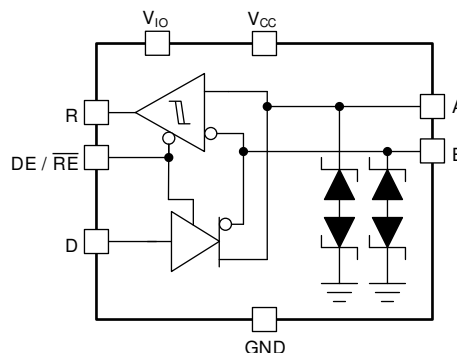


Figure 8-2. THVD1439V and THVD1449V Block Diagram

### 8.3 Feature Description

#### 8.3.1 Electrostatic Discharge (ESD) Protection

The bus pins of the THVD14x9(V) transceiver family include on-chip ESD protection against  $\pm 15\text{-kV}$  HBM and  $\pm 15\text{-kV}$  IEC 61000-4-2 contact discharge. The International Electrotechnical Commission (IEC) ESD test is far more severe than the HBM ESD test. The 50% higher charge capacitance,  $C_{(S)}$ , and 78% lower discharge resistance,  $R_{(D)}$ , of the IEC model produce significantly higher discharge currents than the HBM model. As stated in the IEC 61000-4-2 standard, contact discharge is the preferred transient protection test method.

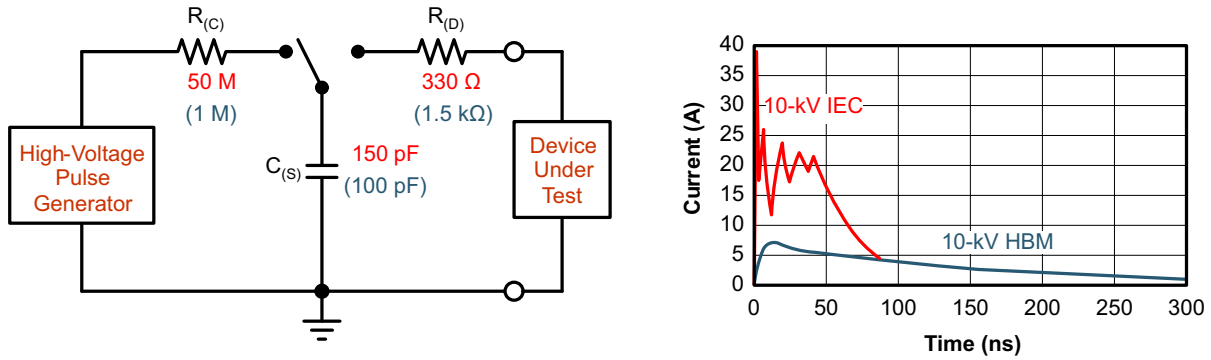


Figure 8-3. HBM and IEC ESD Models and Currents in Comparison (HBM Values in Parenthesis)

The on-chip implementation of IEC ESD protection significantly increases the robustness of equipment. Common discharge events occur because of human contact with connectors and cables.

### 8.3.2 Electrical Fast Transient (EFT) Protection

Inductive loads such as relays, switch contactors, or heavy-duty motors can create high-frequency bursts during transition. The IEC 61000-4-4 test is intended to simulate the transients created by such switching of inductive loads on AC power lines. Figure 8-4 shows the voltage waveforms in to 50-Ω termination as defined by the IEC standard.

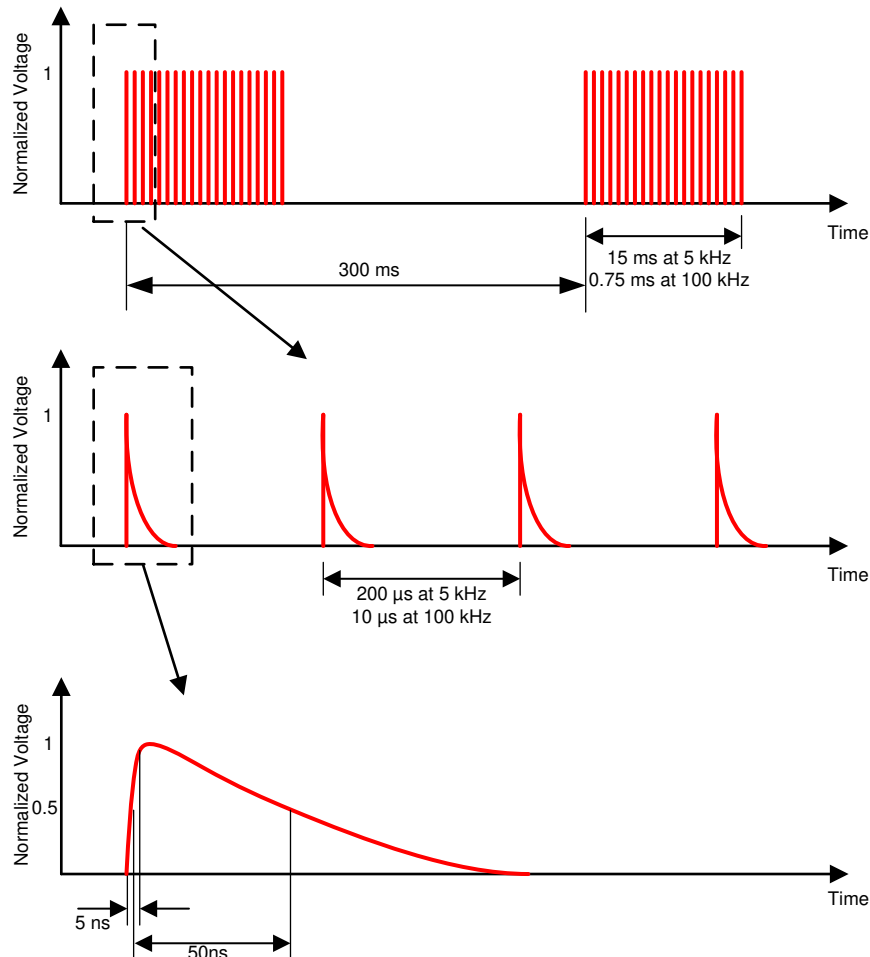


Figure 8-4. EFT Voltage Waveforms

Internal ESD protection circuits of the THVD14x9(V) protect the transceivers against  $\pm 4$ -kV EFT. With careful system design, one could achieve EFT Criterion A (no data loss when transient noise is present).

### 8.3.3 Surge Protection

Surge transients often result from lightning strikes (direct strike or an indirect strike which induce voltages and currents), or the switching of power systems, including load changes and short circuit switching. These transients are often encountered in industrial environments, such as factory automation and power-grid systems.

Figure 8-5 compares the pulse-power of the EFT and surge transients with the power caused by an IEC ESD transient. The diagram on the left shows the relative pulse-power for a 0.5-kV surge transient and 4-kV EFT transient, both of which dwarf the 10-kV ESD transient visible in the lower-left corner. 500-V surge transients are representative of events that may occur in factory environments in industrial and process automation.

The diagram on the right shows the pulse-power of a 6-kV surge transient, relative to the same 0.5-kV surge transient. 6-kV surge transients are most likely to occur in power generation and power-grid systems.

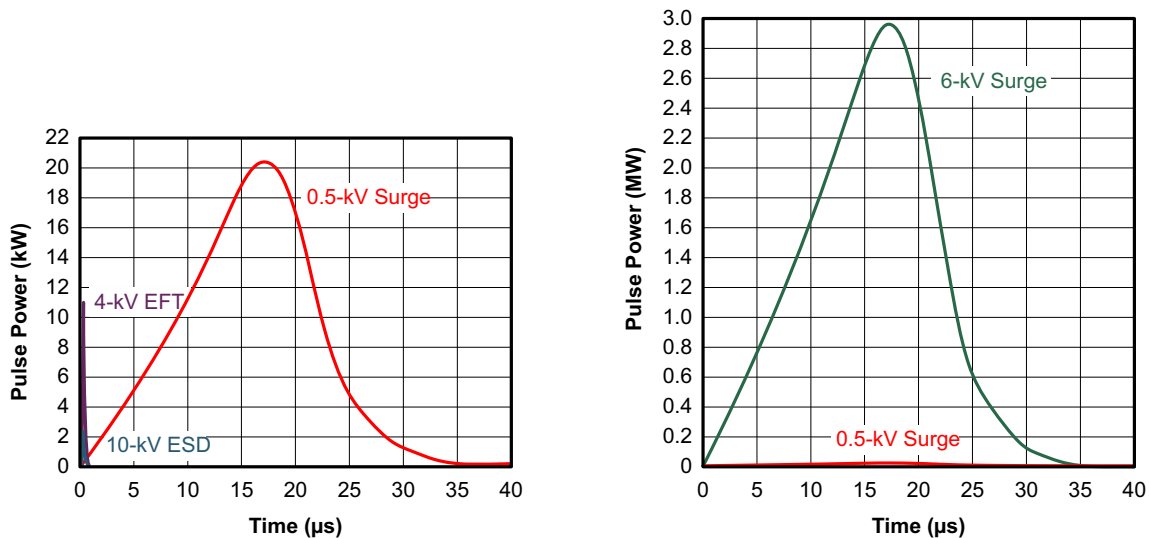


Figure 8-5. Power Comparison of ESD, EFT, and Surge Transients

Figure 8-6 shows the test setup used to validate THVD14x9 surge performance according to the IEC 61000-4-5 1.2/50- $\mu\text{s}$  surge pulse.

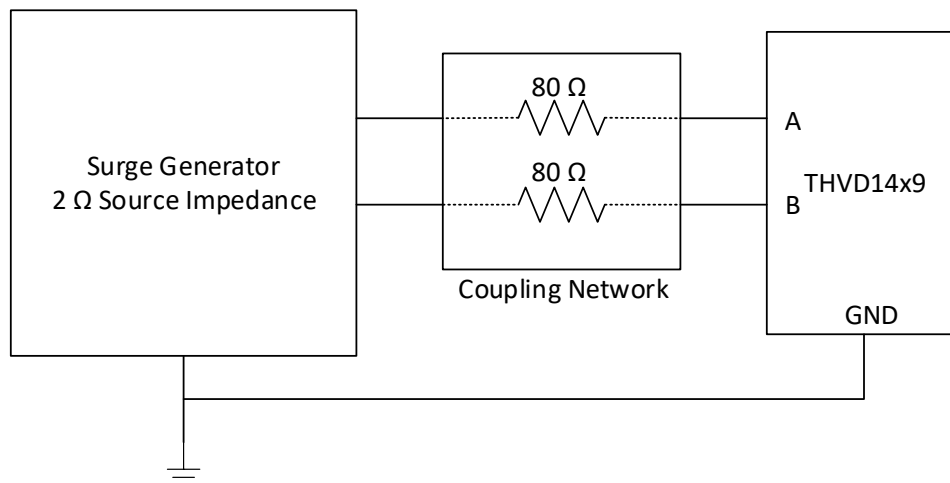
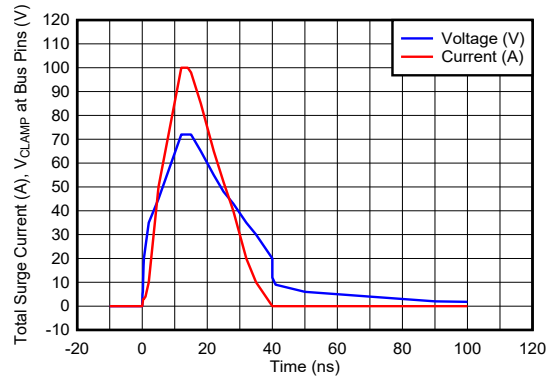
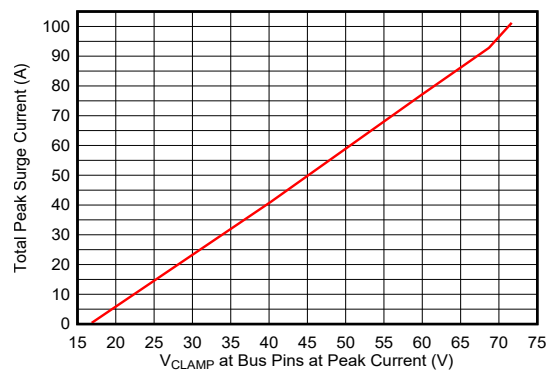


Figure 8-6. THVD14x9(V) Surge Test Setup

THVD14x9(V) product family is robust to  $\pm 4$ -kV surge transients without the need for any external components. The transient current and voltage waveforms resulting from a +4-kV surge test as described in Figure 8-6 are shown in Figure 8-7. The bus pin voltage is clamped by the integrated surge protection diodes such that the internal circuitry is not damaged during the surge event. The clamping voltage at the bus pins for versus the total current from the surge generator is shown in Figure 8-8.



**Figure 8-7. Transient current and voltage waveforms from +4-kV Surge Test. The current waveform is the total current output from the generator and the voltage waveform is the voltage at A or B pin of the transceiver.**



**Figure 8-8. Clamping voltage at bus pins vs total surge current from the surge generator**

### 8.3.4 Enhanced Receiver Noise Immunity

The differential receivers of THVD14x9(V) family feature fully symmetric thresholds to maintain duty cycle of the signal even with small input amplitudes. In addition, 250 mV (typical) hysteresis guarantees excellent noise immunity.

### 8.3.5 Failsafe Receiver

The differential receivers of the THVD14x9(V) family are failsafe to invalid bus states caused by the following:

- Open bus conditions, such as a disconnected connector
- Shorted bus conditions, such as cable damage shorting the twisted-pair together
- Idle bus conditions that occur when no driver on the bus is actively driving

In any of these cases, the receiver will output a fail-safe logic high state if the input amplitude stays for longer than  $t_{D(OFs)}$  at less than  $|V_{TH\_FSH}|$ .

## 8.4 Device Functional Modes

When the driver enable pin, DE, is logic high, the differential outputs A and B follow the logic states at data input D. A logic high at D causes A to turn high and B to turn low. In this case the differential output voltage defined as  $V_{OD} = V_A - V_B$  is positive. When D is low, the output states reverse: B turns high, A becomes low, and  $V_{OD}$  is negative.

When DE is low, both outputs turn high-impedance. In this condition the logic state at D is irrelevant. The DE pin has an internal pull-down resistor to ground, thus when left open the driver is disabled (high-impedance) by default. The D pin has an internal pull-up resistor to  $V_{CC}$ , thus, when left open while the driver is enabled, output A turns high and B turns low.

**Table 8-1. Driver Function Table**

INPUT	ENABLE	OUTPUTS		FUNCTION
		A	B	
H	H	H	L	Actively drive bus high
L	H	L	H	Actively drive bus low
X	L	Z	Z	Driver disabled
X	OPEN	Z	Z	Driver disabled by default
OPEN	H	H	L	Actively drive bus high by default

When the receiver enable pin,  $\overline{RE}$ , is logic low, the receiver is enabled. When the differential input voltage defined as  $V_{ID} = V_A - V_B$  is higher than the positive input threshold,  $V_{TH+}$ , the receiver output, R, turns high. When  $V_{ID}$  is lower than the negative input threshold,  $V_{TH-}$ , the receiver output, R, turns low. If  $V_{ID}$  is between  $V_{TH+}$  and  $V_{TH-}$  the output is indeterminate.

When  $\overline{RE}$  is logic high or left open, the receiver output is high-impedance and the magnitude and polarity of  $V_{ID}$  are irrelevant. Internal biasing of the receiver inputs causes the output to go failsafe-high when the transceiver is disconnected from the bus (open-circuit), the bus lines are shorted to one another (short-circuit), or the bus is not actively driven (idle bus).

**Table 8-2. Receiver Function Table**

DIFFERENTIAL INPUT	ENABLE	OUTPUT	FUNCTION
$V_{ID} = V_A - V_B$	$\overline{RE}$	R	
$V_{TH+} < V_{ID}$	L	H	Receive valid bus high
$V_{TH-} < V_{ID} < V_{TH+}$	L	Indeterminate	Indeterminate bus state
$V_{ID} < V_{TH-}$	L	L	Receive valid bus low
X	H	Z	Receiver disabled
X	OPEN	Z	Receiver disabled by default
Open-circuit bus	L	H	Fail-safe high output
Short-circuit bus	L	H	Fail-safe high output
Idle (terminated) bus	L	H	Fail-safe high output

## 9 Application and Implementation

### Note

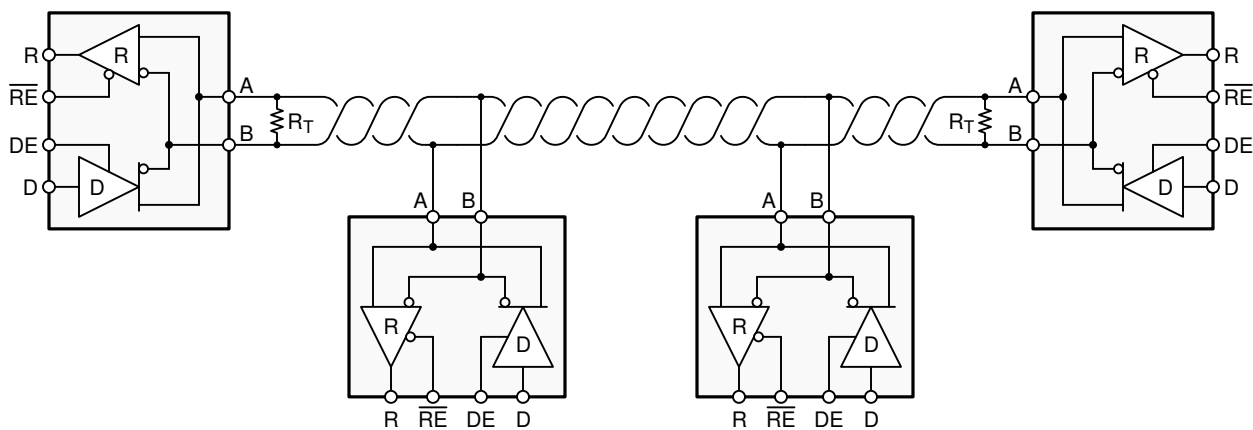
Information in the following applications sections is not part of the TI component specification, and TI does not warrant its accuracy or completeness. TI's customers are responsible for determining suitability of components for their purposes, as well as validating and testing their design implementation to confirm system functionality.

### 9.1 Application Information

THVD14x9(V) are half-duplex RS-485 transceivers with integrated system-level surge protection. Standard 8-pin SOIC (D) package allows drop-in replacement into existing systems and eliminate system-level protection components.

### 9.2 Typical Application

An RS-485 bus consists of multiple transceivers connecting in parallel to a bus cable. To eliminate line reflections, each cable end is terminated with a termination resistor,  $R_T$ , with a value that matches the characteristic impedance,  $Z_0$ , of the cable. This method, known as parallel termination, allows for higher data rates over longer cable length.



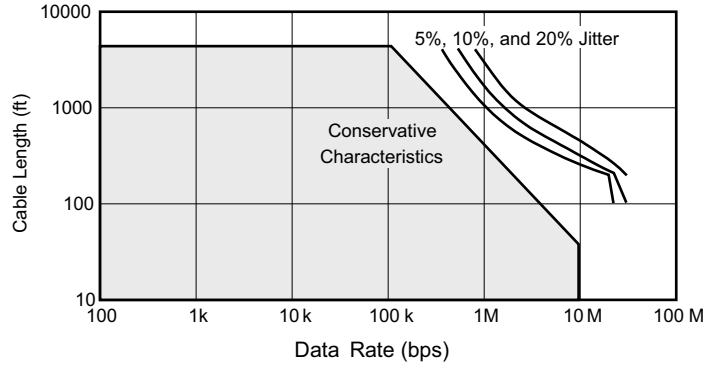
**Figure 9-1. Typical RS-485 Network With Half-Duplex Transceivers**

#### 9.2.1 Design Requirements

RS-485 is a robust electrical standard suitable for long-distance networking that may be used in a wide range of applications with varying requirements, such as distance, data rate, and number of nodes.

##### 9.2.1.1 Data Rate and Bus Length

There is an inverse relationship between data rate and cable length, which means the higher the data rate, the shorter the cable length; and conversely, the lower the data rate, the longer the cable length. While most RS-485 systems use data rates between 10 kbps and 100 kbps, some applications require data rates up to 250 kbps at distances of 4000 feet and longer. Longer distances are possible by allowing for small signal jitter of up to 5 or 10%.



**Figure 9-2. Cable Length vs Data Rate Characteristic**

Even higher data rates are achievable (that is, 12 Mbps for the THVD1449(V)) in cases where the interconnect is short enough (or has suitably low attenuation at signal frequencies) to not degrade the data.

### 9.2.1.2 Stub Length

When connecting a node to the bus, the distance between the transceiver inputs and the cable trunk, known as the stub, should be as short as possible. Stubs present a non-terminated piece of bus line which can introduce reflections as the length of the stub increases. As a general guideline, the electrical length, or round-trip delay, of a stub should be less than one-tenth of the rise time of the driver, thus giving a maximum physical stub length as shown in Equation 1.

$$L_{(\text{STUB})} \leq 0.1 \times t_r \times v \times c \tag{1}$$

where

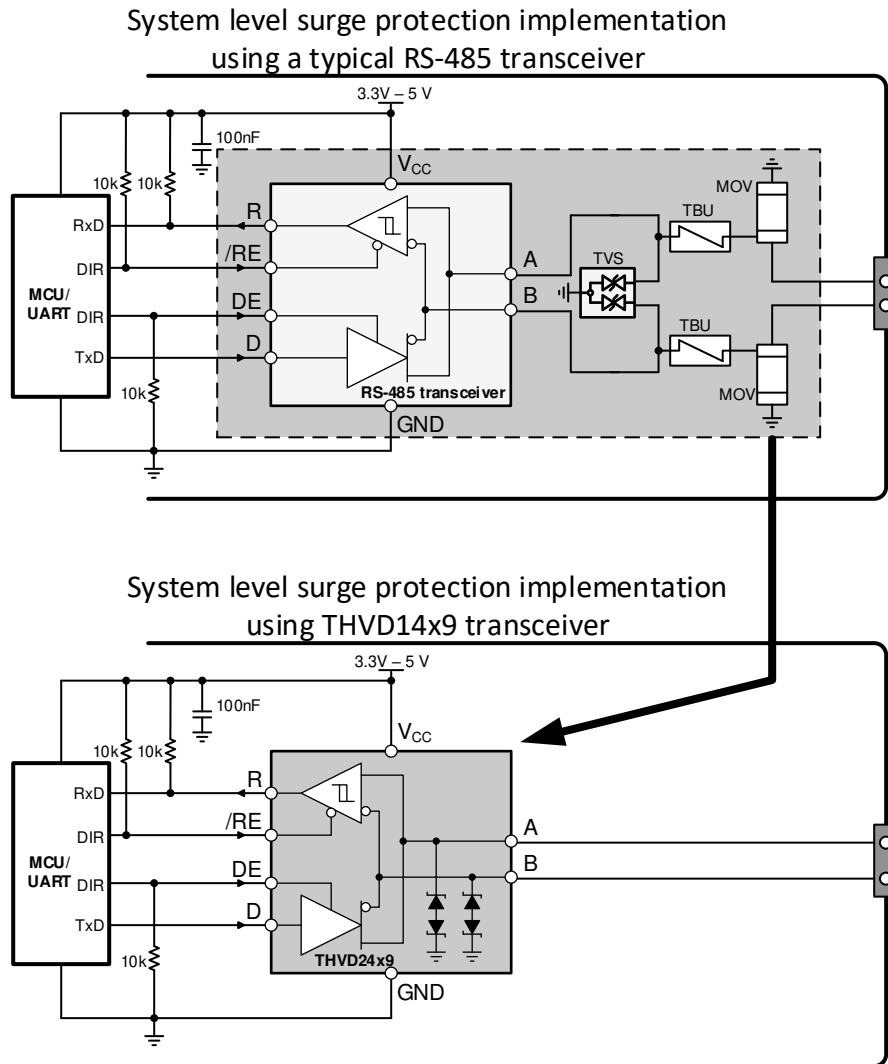
- $t_r$  is the 10/90 rise time of the driver
- $c$  is the speed of light ( $3 \times 10^8$  m/s)
- $v$  is the signal velocity of the cable or trace as a factor of  $c$

### 9.2.1.3 Bus Loading

The RS-485 standard specifies that a compliant driver must be able to driver 32 unit loads (UL), where 1 unit load represents a load impedance of approximately 12 kΩ. Because the THVD14x9(V) devices consist of 1/8 UL transceivers, connecting up to 256 receivers to the bus is possible.

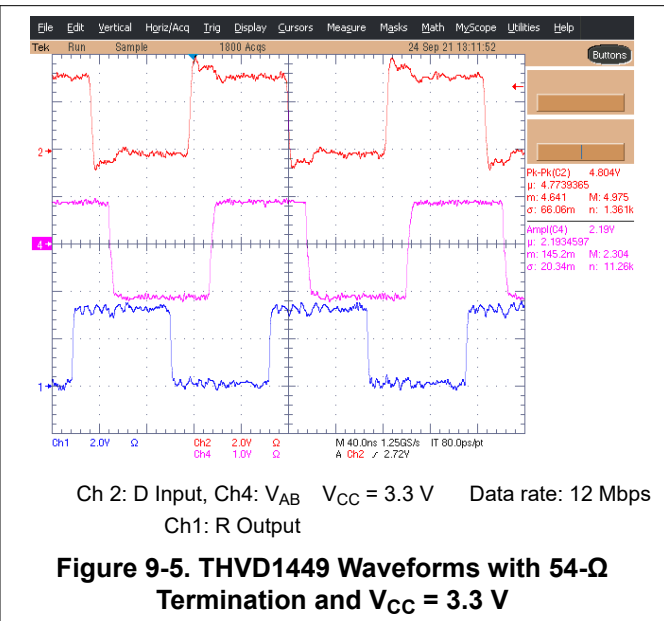
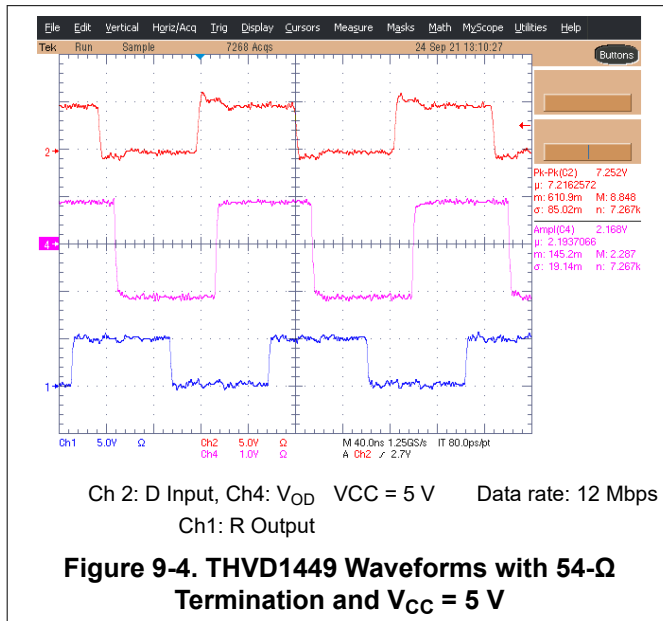
### 9.2.2 Detailed Design Procedure

RS-485 transceivers operate in noisy industrial environments typically require surge protection at the bus pins. Figure 9-3 compares 4-kV surge protection implementation with a regular RS-485 transceiver (such as THVD14x0) against with the THVD14x9(V). The internal TVS protection of the THVD14x9(V) achieves  $\pm 4$ -kV IEC 61000-4-5 surge protection without any additional external components, reducing system level bill of materials.



**Figure 9-3. Implementation of System-Level Surge Protection Using THVD14x9(V)**

### 9.2.3 Application Curves



## 10 Power Supply Recommendations

To ensure reliable operation at all data rates and supply voltages, each supply should be decoupled with a 100 nF ceramic capacitor located as close to the supply pins as possible. This helps to reduce supply voltage ripple present on the outputs of switched-mode power supplies and also helps to compensate for the resistance and inductance of the PCB power planes.

## 11 Layout

### 11.1 Layout Guidelines

Additional external protection components generally are not needed when using THVD14x9(V) transceivers.

1. Use  $V_{CC}$  and ground planes to provide low-inductance. Note that high-frequency currents tend to follow the path of least impedance and not the path of least resistance. Apply 100-nF to 220-nF decoupling capacitors as close as possible to the  $V_{CC}$  pins of transceiver, UART and/or controller ICs on the board.
2. Use at least two vias for  $V_{CC}$  and ground connections of decoupling capacitors to minimize effective via inductance.
3. Use 1-k $\Omega$  to 10-k $\Omega$  pull-up and pull-down resistors for enable lines to limit noise currents in these lines during transient events.

### 11.2 Layout Example

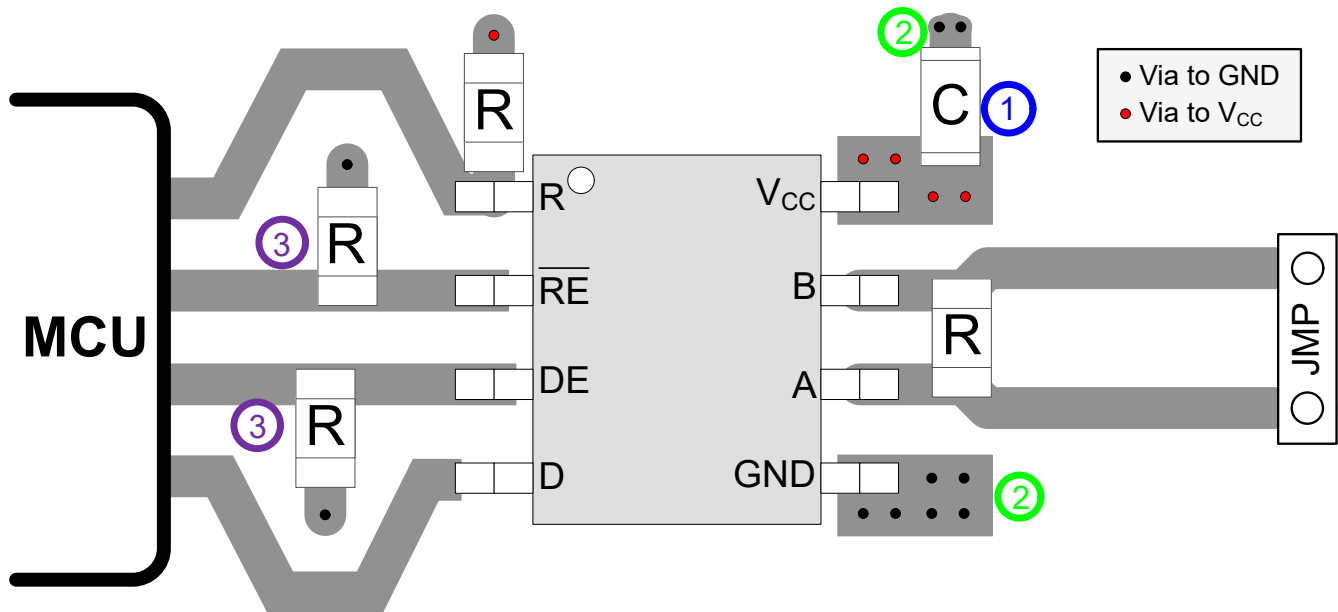


Figure 11-1. THVD1439, THVD1449 Layout Example

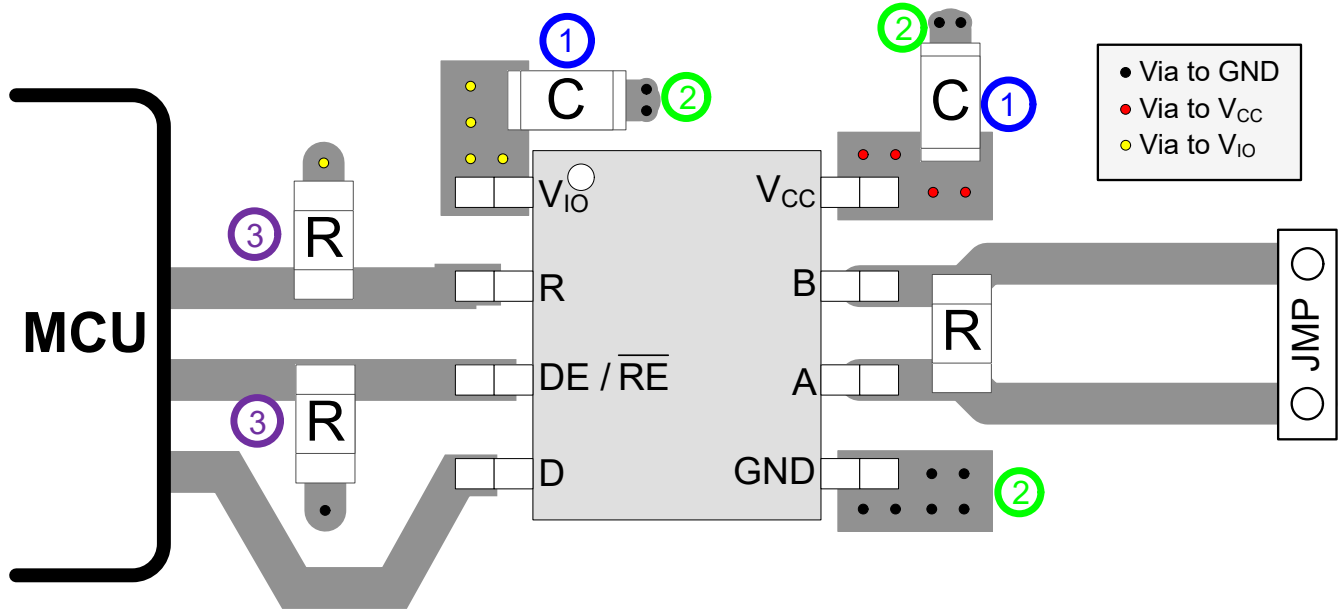


Figure 11-2. THVD1439V THVD1449V Layout Example

## 12 Device and Documentation Support

### 12.1 Device Support

### 12.2 Receiving Notification of Documentation Updates

To receive notification of documentation updates, navigate to the device product folder on [ti.com](http://ti.com). Click on *Subscribe to updates* to register and receive a weekly digest of any product information that has changed. For change details, review the revision history included in any revised document.

### 12.3 Support Resources

[TI E2E™ support forums](#) are an engineer's go-to source for fast, verified answers and design help — straight from the experts. Search existing answers or ask your own question to get the quick design help you need.

Linked content is provided "AS IS" by the respective contributors. They do not constitute TI specifications and do not necessarily reflect TI's views; see TI's [Terms of Use](#).

### 12.4 Trademarks

TI E2E™ is a trademark of Texas Instruments.  
All trademarks are the property of their respective owners.

### 12.5 Electrostatic Discharge Caution



This integrated circuit can be damaged by ESD. Texas Instruments recommends that all integrated circuits be handled with appropriate precautions. Failure to observe proper handling and installation procedures can cause damage.

ESD damage can range from subtle performance degradation to complete device failure. Precision integrated circuits may be more susceptible to damage because very small parametric changes could cause the device not to meet its published specifications.

### 12.6 Glossary

[TI Glossary](#) This glossary lists and explains terms, acronyms, and definitions.

## Mechanical, Packaging, and Orderable Information

The following pages include mechanical, packaging, and orderable information. This information is the most current data available for the designated devices. This data is subject to change without notice and revision of this document. For browser-based versions of this data sheet, refer to the left-hand navigation.

## PACKAGING INFORMATION

Orderable Device	Status (1)	Package Type	Package Drawing	Pins	Package Qty	Eco Plan (2)	Lead finish/ Ball material (6)	MSL Peak Temp (3)	Op Temp (°C)	Device Marking (4/5)	Samples
THVD1439DR	ACTIVE	SOIC	D	8	2500	RoHS & Green	NIPDAUAG	Level-3-260C-168 HR	-40 to 125	T1439	<a href="#">Samples</a>
THVD1439VDR	ACTIVE	SOIC	D	8	2500	RoHS & Green	NIPDAUAG	Level-3-260C-168 HR	-40 to 125	1439V	<a href="#">Samples</a>
THVD1449DR	ACTIVE	SOIC	D	8	2500	RoHS & Green	NIPDAUAG	Level-3-260C-168 HR	-40 to 125	T1449	<a href="#">Samples</a>
THVD1449VDR	ACTIVE	SOIC	D	8	2500	RoHS & Green	NIPDAUAG	Level-3-260C-168 HR	-40 to 125	T1449V	<a href="#">Samples</a>

(1) The marketing status values are defined as follows:

**ACTIVE:** Product device recommended for new designs.

**LIFEBUY:** TI has announced that the device will be discontinued, and a lifetime-buy period is in effect.

**NRND:** Not recommended for new designs. Device is in production to support existing customers, but TI does not recommend using this part in a new design.

**PREVIEW:** Device has been announced but is not in production. Samples may or may not be available.

**OBSOLETE:** TI has discontinued the production of the device.

(2) **RoHS:** TI defines "RoHS" to mean semiconductor products that are compliant with the current EU RoHS requirements for all 10 RoHS substances, including the requirement that RoHS substance do not exceed 0.1% by weight in homogeneous materials. Where designed to be soldered at high temperatures, "RoHS" products are suitable for use in specified lead-free processes. TI may reference these types of products as "Pb-Free".

**RoHS Exempt:** TI defines "RoHS Exempt" to mean products that contain lead but are compliant with EU RoHS pursuant to a specific EU RoHS exemption.

**Green:** TI defines "Green" to mean the content of Chlorine (Cl) and Bromine (Br) based flame retardants meet JS709B low halogen requirements of <=1000ppm threshold. Antimony trioxide based flame retardants must also meet the <=1000ppm threshold requirement.

(3) MSL, Peak Temp. - The Moisture Sensitivity Level rating according to the JEDEC industry standard classifications, and peak solder temperature.

(4) There may be additional marking, which relates to the logo, the lot trace code information, or the environmental category on the device.

(5) Multiple Device Markings will be inside parentheses. Only one Device Marking contained in parentheses and separated by a "-" will appear on a device. If a line is indented then it is a continuation of the previous line and the two combined represent the entire Device Marking for that device.

(6) Lead finish/Ball material - Orderable Devices may have multiple material finish options. Finish options are separated by a vertical ruled line. Lead finish/Ball material values may wrap to two lines if the finish value exceeds the maximum column width.

**Important Information and Disclaimer:** The information provided on this page represents TI's knowledge and belief as of the date that it is provided. TI bases its knowledge and belief on information provided by third parties, and makes no representation or warranty as to the accuracy of such information. Efforts are underway to better integrate information from third parties. TI has taken and

continues to take reasonable steps to provide representative and accurate information but may not have conducted destructive testing or chemical analysis on incoming materials and chemicals. TI and TI suppliers consider certain information to be proprietary, and thus CAS numbers and other limited information may not be available for release.

In no event shall TI's liability arising out of such information exceed the total purchase price of the TI part(s) at issue in this document sold by TI to Customer on an annual basis.

**TAPE AND REEL INFORMATION**

**QUADRANT ASSIGNMENTS FOR PIN 1 ORIENTATION IN TAPE**


\*All dimensions are nominal

Device	Package Type	Package Drawing	Pins	SPQ	Reel Diameter (mm)	Reel Width W1 (mm)	A0 (mm)	B0 (mm)	K0 (mm)	P1 (mm)	W (mm)	Pin1 Quadrant
THVD1439DR	SOIC	D	8	2500	330.0	12.4	6.4	5.2	2.1	8.0	12.0	Q1
THVD1439VDR	SOIC	D	8	2500	330.0	12.4	6.4	5.2	2.1	8.0	12.0	Q1
THVD1449DR	SOIC	D	8	2500	330.0	12.4	6.4	5.2	2.1	8.0	12.0	Q1
THVD1449VDR	SOIC	D	8	2500	330.0	12.4	6.4	5.2	2.1	8.0	12.0	Q1

**TAPE AND REEL BOX DIMENSIONS**


\*All dimensions are nominal

Device	Package Type	Package Drawing	Pins	SPQ	Length (mm)	Width (mm)	Height (mm)
THVD1439DR	SOIC	D	8	2500	346.0	346.0	29.0
THVD1439VDR	SOIC	D	8	2500	346.0	346.0	29.0
THVD1449DR	SOIC	D	8	2500	346.0	346.0	29.0
THVD1449VDR	SOIC	D	8	2500	346.0	346.0	29.0

## IMPORTANT NOTICE AND DISCLAIMER

TI PROVIDES TECHNICAL AND RELIABILITY DATA (INCLUDING DATA SHEETS), DESIGN RESOURCES (INCLUDING REFERENCE DESIGNS), APPLICATION OR OTHER DESIGN ADVICE, WEB TOOLS, SAFETY INFORMATION, AND OTHER RESOURCES "AS IS" AND WITH ALL FAULTS, AND DISCLAIMS ALL WARRANTIES, EXPRESS AND IMPLIED, INCLUDING WITHOUT LIMITATION ANY IMPLIED WARRANTIES OF MERCHANTABILITY, FITNESS FOR A PARTICULAR PURPOSE OR NON-INFRINGEMENT OF THIRD PARTY INTELLECTUAL PROPERTY RIGHTS.

These resources are intended for skilled developers designing with TI products. You are solely responsible for (1) selecting the appropriate TI products for your application, (2) designing, validating and testing your application, and (3) ensuring your application meets applicable standards, and any other safety, security, regulatory or other requirements.

These resources are subject to change without notice. TI grants you permission to use these resources only for development of an application that uses the TI products described in the resource. Other reproduction and display of these resources is prohibited. No license is granted to any other TI intellectual property right or to any third party intellectual property right. TI disclaims responsibility for, and you will fully indemnify TI and its representatives against, any claims, damages, costs, losses, and liabilities arising out of your use of these resources.

TI's products are provided subject to [TI's Terms of Sale](#) or other applicable terms available either on [ti.com](http://ti.com) or provided in conjunction with such TI products. TI's provision of these resources does not expand or otherwise alter TI's applicable warranties or warranty disclaimers for TI products.

TI objects to and rejects any additional or different terms you may have proposed.

Mailing Address: Texas Instruments, Post Office Box 655303, Dallas, Texas 75265  
Copyright © 2022, Texas Instruments Incorporated

## Looking for pricing, stock, or lifecycle information?

Click below to explore more details on WIN SOURCE:

 [View THVD1449DR](#) on WIN SOURCE

 [Texas Instruments](#) Information

## Optimize Your Supply Chain with WIN SOURCE Solutions

-  Global Sourcing Solution
-  Obsolete Management
-  Cost Control Management
-  Shortage Management
-  Alternative Solution
-  Excess Inventory Management