



**THE DATASHEET OF  
IPS7081STRLPBF**



# IPS7081(R)(S)PbF

## INTELLIGENT POWER HIGH SIDE SWITCH

### Features

- Over temperature shutdown (with auto-restart)
- Short circuit protection (current limit)
- Active clamp
- Open load detection
- Logic ground isolated from power ground
- ESD protection
- Ground loss protection
- Status feedback

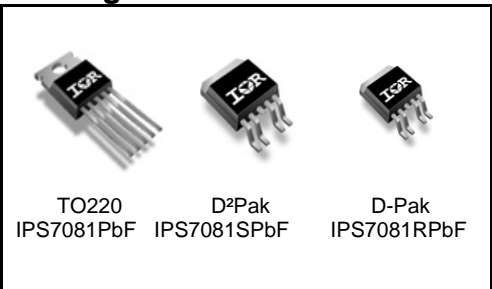
### Product Summary

Rds(on)	70mΩ max.
Vclamp	70V
I Limit	5A (typ.)
Open load	3V

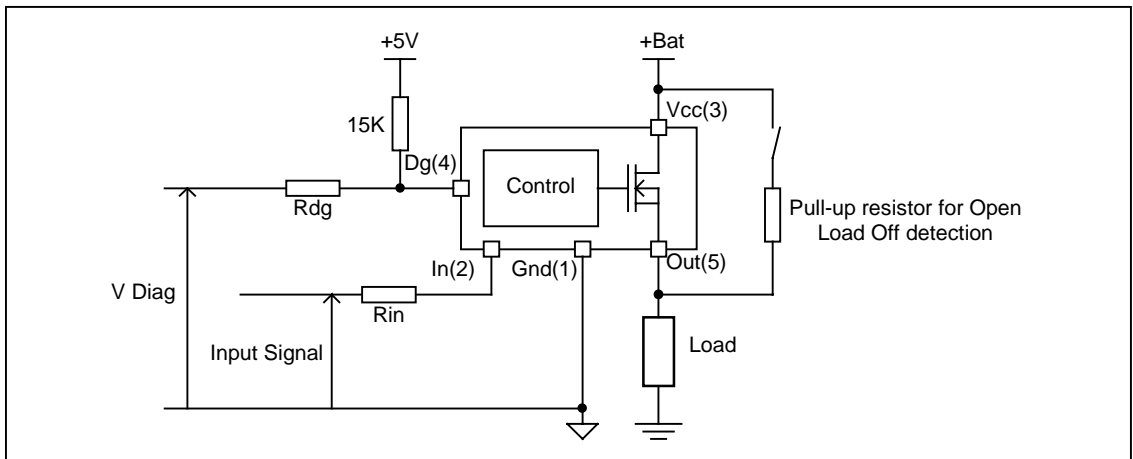
### Description

The IPS7081(R)(S)PbF is a five terminal Intelligent Power Switch (IPS) with built in short circuit, over-temperature, ESD protection, inductive load capability and diagnostic feedback. The output current is limited at Ilim value. Current limitation is activated until the thermal protection acts. The over-temperature protection turns off the device if the junction temperature exceeds Tshutdown. It will automatically restart after the junction has cooled 7°C below Tshutdown. A diagnostic pin is provided for status feedback of short circuit, over-temperature and open load detection. The double level shifter circuitry allows large offsets between the logic ground and the load.

### Package



### Typical Connection



## Absolute Maximum Ratings

Absolute maximum ratings indicate sustained limits beyond which damage to the device may occur. All voltage parameters are referenced to Ground lead. (Tambient=25°C unless otherwise specified).

Symbol	Parameter	Min.	Max.	Units
Vout	Maximum output voltage	Vcc-65	Vcc+0.3	V
Voffset	Maximum logic ground to load ground offset	Vcc-65	Vcc+0.3	
Vin	Maximum input voltage	-0.3	5.5	
Vcc max.	Maximum Vcc voltage	—	65	
Vcc cont.	Maximum continuous Vcc voltage	—	35	
Iin max.	Maximum IN current	-1	10	mA
I <sub>dg</sub> max.	Maximum diagnostic output current	-1	10	
V <sub>dg</sub>	Maximum diagnostic output voltage	-0.3	5.5	V
P <sub>d</sub>	Maximum power dissipation (internally limited by thermal protection) R <sub>th</sub> =50°C/W	—	2.5	W
I <sub>sd</sub> cont.	Maximum continuous diode current (R <sub>th</sub> =50°C/W)	—	2.2	A
ESD1	Electrostatic discharge voltage (Human body) 100pF, 1500Ω	—	4	kV
ESD2	Electrostatic discharge voltage (Machine Model) C=200pF, R=0Ω, L=10μH	—	0.5	
T <sub>j</sub> max.	Max. storage & operating temperature junction temperature	-40	+150	°C

## Thermal Characteristics

Symbol	Parameter	Typ.	Max.	Units
R <sub>th1</sub>	Thermal resistance junction to ambient D-Pak std. footprint	70	—	°C/W
R <sub>th2</sub>	Thermal resistance junction to ambient D-Pak 1" sqft. footprint	50	—	
R <sub>th3</sub>	Thermal resistance junction to case D-Pak / TO220 / D <sup>2</sup> Pak	3	—	
R <sub>th1</sub>	Thermal resistance junction to ambient TO220 free air	60	—	

## Recommended Operating Conditions

These values are given for a quick design. For operation outside these conditions, please consult the application notes.

Symbol	Parameter	Min.	Max.	Units
V <sub>IH</sub>	High level input voltage	4	5.5	
V <sub>IL</sub>	Low level input voltage	-0.3	0.9	
I <sub>out</sub>	Continuous drain current, T <sub>amb</sub> =85°C, T <sub>j</sub> =125°C, V <sub>in</sub> =5V, R <sub>th</sub> =50°C/W	—	2.3	A
R <sub>in</sub>	Recommended resistor in series with IN pin	4	10	kΩ
R <sub>dg</sub>	Recommended resistor in series with DG pin	10	20	
R <sub>ol</sub>	Recommended pull-up resistor for open load detection	5	100	

## Static Electrical Characteristics

$T_j=25^\circ\text{C}$ ,  $V_{cc}=14\text{V}$  (unless otherwise specified)

Symbol	Parameter	Min.	Typ.	Max.	Units	Test Conditions
Rds(on)	ON state resistance $T_j=25^\circ\text{C}$	—	55	70	m $\Omega$	$V_{in}=5\text{V}$ , $I_{out}=2\text{A}$
	ON state resistance $T_j=150^\circ\text{C}$	—	100	130		$V_{in}=5\text{V}$ , $I_{out}=2\text{A}$
	ON state resistance $T_j=25^\circ\text{C}$ , $V_{cc}=6.5\text{V}$	—	60	80		$V_{in}=5\text{V}$ , $I_{out}=2\text{A}$
Vcc op.	Operating voltage range	6	—	35	V	
V clamp 1	Vcc to Out clamp voltage 1	65	70	—		$I_{out}=30\text{mA}$ (see Fig. 1)
V clamp 2	Vcc to Out clamp voltage 2	—	70	75		$I_{out}=2\text{A}$ (see Fig. 1)
Vf	Body diode forward voltage	—	1	1.35		$I_{out}=2.5\text{A}$
Icc Off	Supply current when Off	—	2.5	10	$\mu\text{A}$	$V_{in}=0\text{V}$ , $V_{out}=0\text{V}$
Icc On	Supply current when On	—	2.5	3.5	mA	$V_{in}=5\text{V}$
Iout@0V	Output leakage current	—	2.5	10	$\mu\text{A}$	$V_{out}=0\text{V}$
Iout@6V	Output leakage current	—	20	—		$V_{out}=6\text{V}$
I <sub>dg</sub> leakage	Diagnostic output leakage current	—	—	10		$V_{dg}=5.5\text{V}$
V <sub>dgl</sub>	Low level diagnostic output voltage	—	0.2	0.3		$I_{dg}=1.6\text{mA}$
V <sub>ih</sub>	Input high threshold voltage	—	2.5	3.5	V	
V <sub>il</sub>	Input low threshold voltage	1	2	—		
I <sub>n hys</sub>	Input hysteresis	0.15	0.5	1		
UV high	Under voltage high threshold voltage	—	5	5.9		
UV low	Under voltage low threshold voltage	3.4	4.5	—		
UV hys	Undervoltage hysteresis	0.1	0.5	1.5		
I <sub>in</sub> On	Input current when device is On	—	40	80	$\mu\text{A}$	$V_{in}=5\text{V}$

## Switching Electrical Characteristics

$V_{cc}=14\text{V}$ , Resistive load=6 $\Omega$ ,  $V_{in}=5\text{V}$ ,  $T_j=25^\circ\text{C}$

Symbol	Parameter	Min.	Typ.	Max.	Units	Test Conditions
T <sub>don</sub>	Turn-on delay time	—	16	45	$\mu\text{s}$	See Fig. 3
Tr1	Rise time to $V_{out}=V_{cc}-5\text{V}$	—	10	40		
Tr2	Rise time to $V_{out}=0.9 \times V_{cc}$	—	20	100		
dV/dt (On)	Turn On dV/dt	—	0.8	3	V/ $\mu\text{s}$	
E <sub>On</sub>	Turn On energy	—	100	—	$\mu\text{J}$	
T <sub>doff</sub>	Turn-off delay time	—	25	50	$\mu\text{s}$	
T <sub>f</sub>	Fall time to $V_{out}=0.1 \times V_{cc}$	—	7.5	25	$\mu\text{s}$	
dV/dt (Off)	Turn Off dV/dt	—	1.6	3	V/ $\mu\text{s}$	
E <sub>Off</sub>	Turn Off energy	—	25	—	$\mu\text{J}$	
T <sub>diag</sub>	$V_{out}$ to $V_{diag}$ propagation delay	—	15	—	$\mu\text{s}$	See Fig. 4 and Fig. 12

### Protection Characteristics

Symbol	Parameter	Min.	Typ.	Max.	Units	Test Conditions
Ilim	Internal current limit	2	7	10	A	Vout=0V
Tsd+	Over temperature high threshold	150 <sup>(1)</sup>	165	—	°C	See Fig. 2
Tsd-	Over temperature low threshold	—	158	—		
Vsc	Short-circuit detection voltage <sup>(2)</sup>	2	3	4	V	
Vopen load	Open load detection threshold	2	3	4		

<sup>(1)</sup> Guaranteed by design

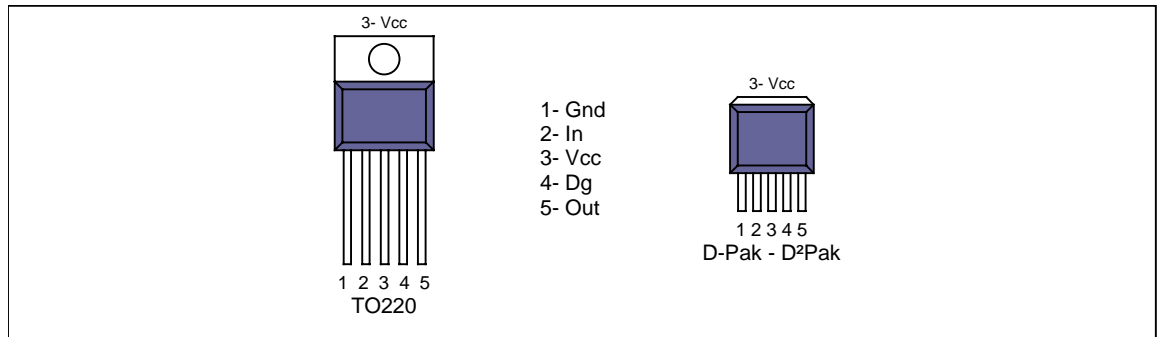
<sup>(2)</sup> Reference to Vcc

### Truth Table

Operating Conditions	IN	OUT	DG pin
Normal	H	H	H
Normal	L	L	L
Open Load	H	H	H
Open Load <sup>(3)</sup>	L	H	H
Short circuit to Gnd	H	L (limiting)	L
Short circuit to Gnd	L	L	L
Over-temperature	H	L (cycling)	L
Over-temperature	L	L	L

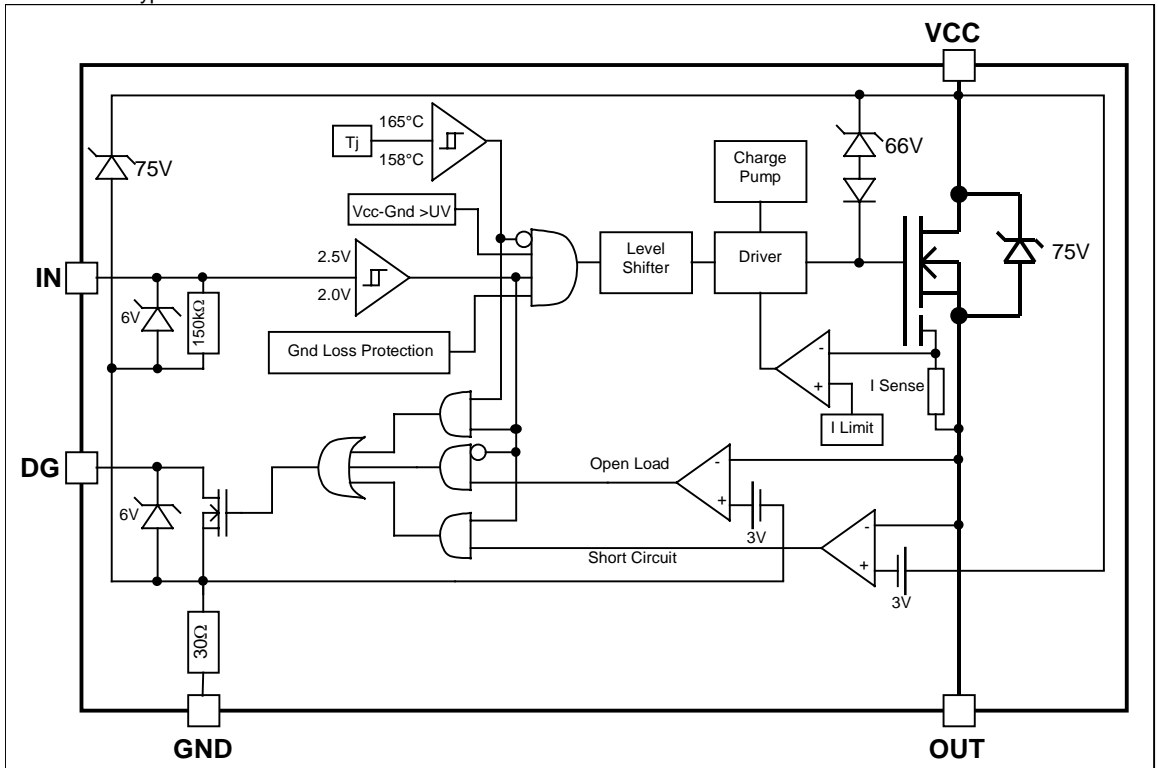
<sup>(3)</sup> With a pull-up resistor connected between the output and Vcc.

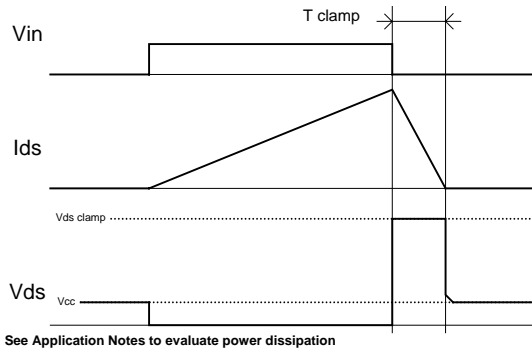
### Lead Assignments



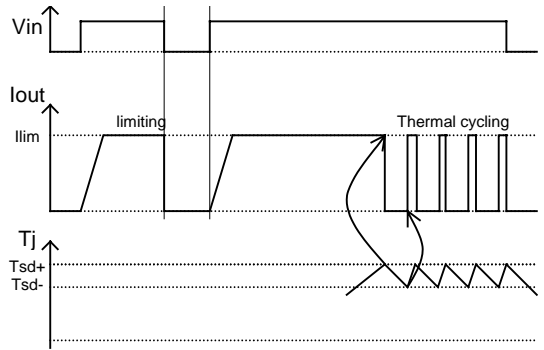
**Functional Block Diagram**

All values are typical

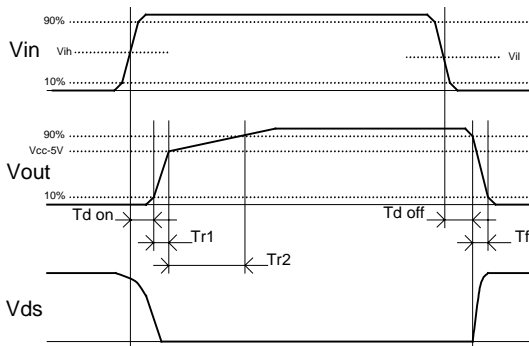




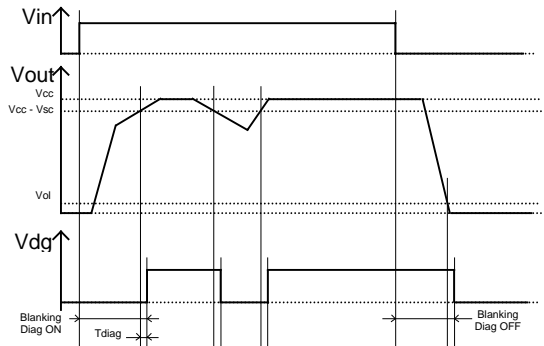
**Figure 1 – Active clamp waveforms**



**Figure 2 – Protection timing diagram**



**Figure 3 – Switching times definition**



**Figure 4 – Diagnostic delay definition**

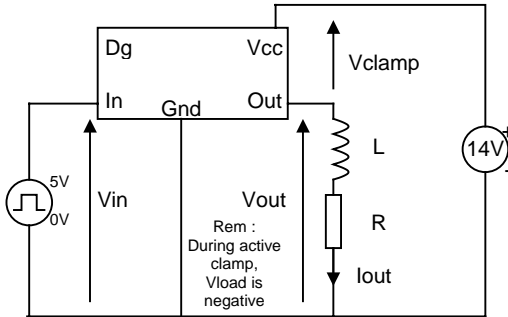


Figure 5 – Active clamp test circuit

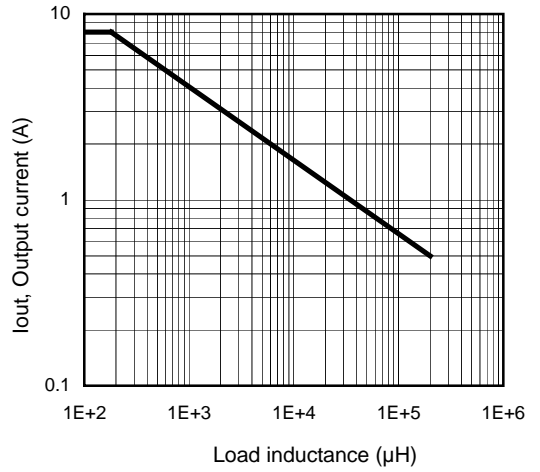


Figure 6 – Max. Output current (A) Vs Load inductance (µH)

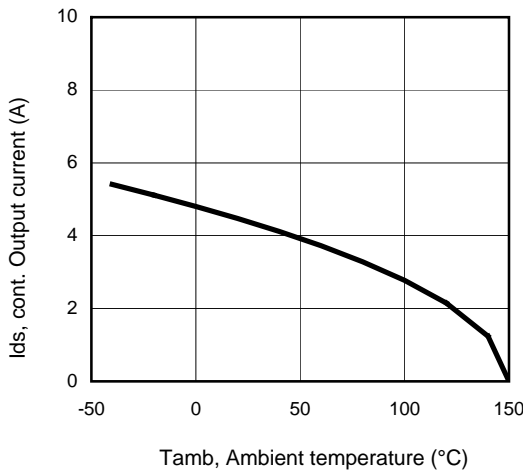


Figure 7 – Max. output current (A) Vs Ambient temperature (°C) R<sub>th</sub>=50°C/W

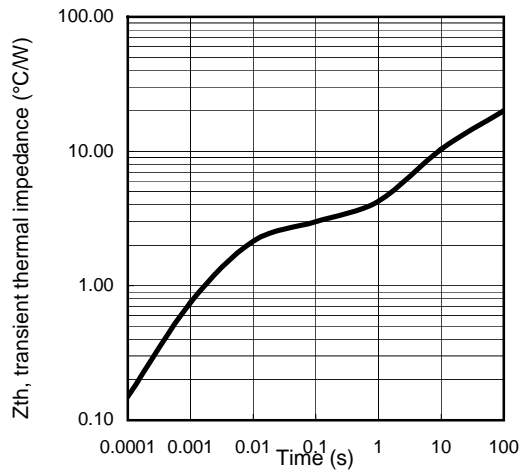
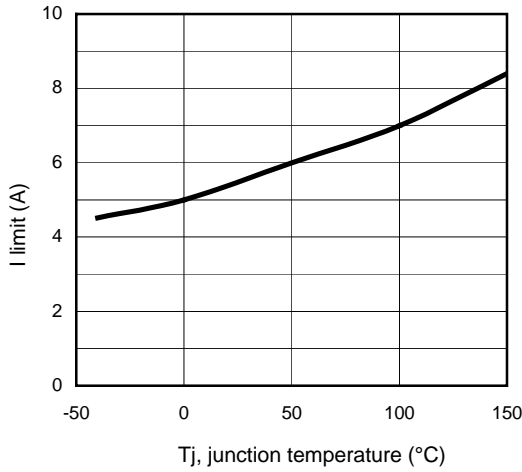
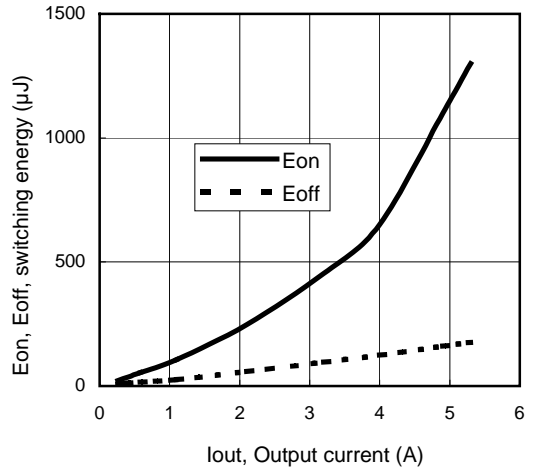


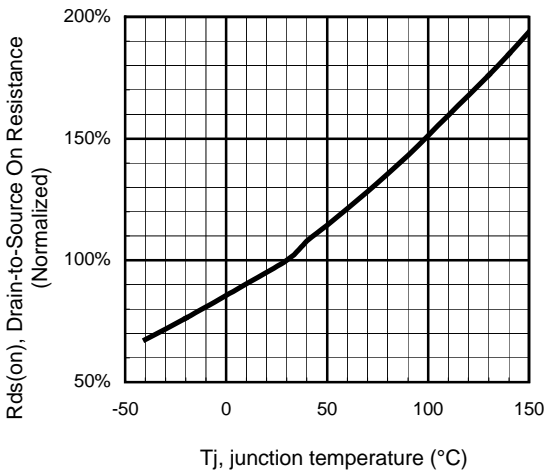
Figure 8 – Transient thermal impedance (°C/W) Vs time (s)



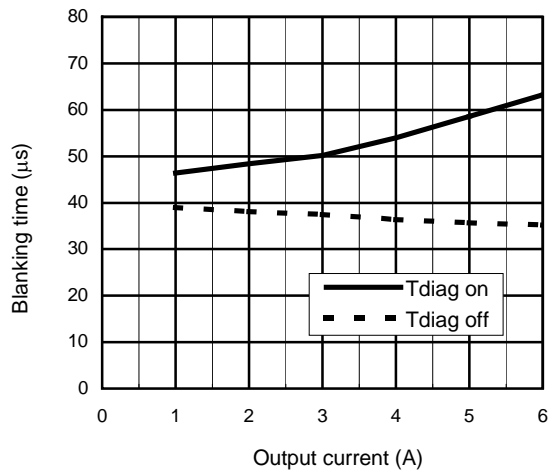
**Figure 9 – I limit (A)  
 Vs junction temperature (°C)**



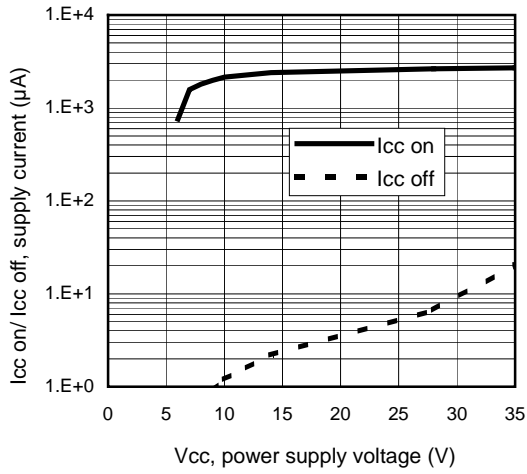
**Figure 10 – Switching energy (µJ) Vs Output current (A)**



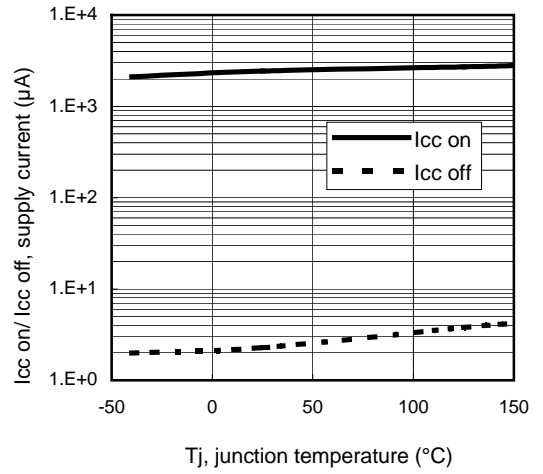
**Figure 11 - Normalized R<sub>ds(on)</sub> (%) Vs T<sub>j</sub> (°C)**



**Figure 12 – Diagnosis Blanking time (µs) Vs Output current (A)**

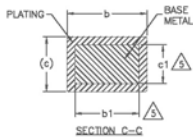
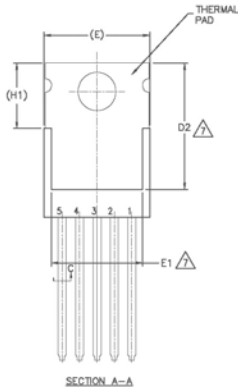
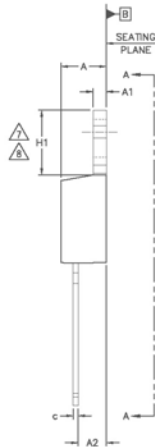
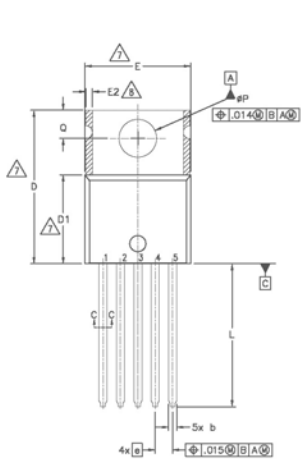


**Figure 13 – Icc on/ Icc off (µA) Vs Vcc (V)**



**Figure 14 – Icc on/ Icc off (µA) Vs Tj (°C)**

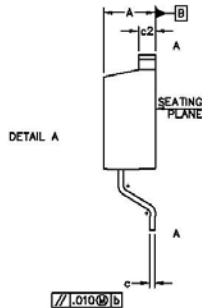
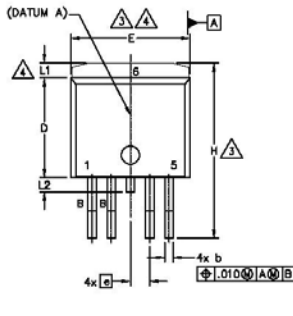
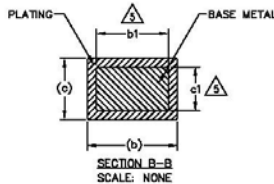
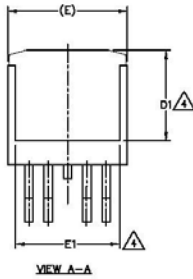
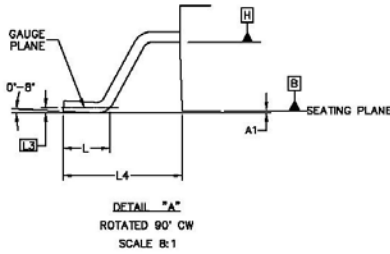
## Case outline – TO220 – 5 leads



SYMBOL	DIMENSIONS				NOMINAL
	MILLIMETERS		INCHES		
	MIN.	MAX.	MIN.	MAX.	
A	3.56	4.83	.140	.190	5
A1	0.51	1.40	.020	.055	
A2	2.03	2.92	.080	.115	
b	0.64	0.89	.025	.035	
b1	0.64	0.84	.025	.033	
c	0.36	0.61	.014	.024	5
c1	0.36	0.56	.014	.022	
D	14.22	16.51	.560	.650	4
D1	6.36	9.02	.330	.355	7
D2	11.58	12.88	.460	.507	
E	9.65	10.67	.380	.420	4,7
E1	6.86	8.89	.270	.350	7
E2	—	0.76	—	.030	8
e	1.70 BSC		.067 BSC		7,8
H1	5.84	6.86	.230	.270	
L	12.70	14.73	.500	.580	
#P	3.53	3.73	.139	.147	
Q	2.54	3.05	.100	.120	

- NOTES:
- 1.- DIMENSIONING AND TOLERANCING AS PER ASME Y14.5 M- 1994.
  - 2.- DIMENSIONS ARE SHOWN IN INCHES [MILLIMETERS]
  - 3.- LEAD DIMENSION AND FINISH UNCONTROLLED IN L1.
  - 4.- DIMENSION D, D1 & E DO NOT INCLUDE MOLD FLASH. MOLD FLASH SHALL NOT EXCEED .005" (0.127) PER SIDE. THESE DIMENSIONS ARE MEASURED AT THE OUTERMOST EXTREMES OF THE PLASTIC BODY.
  - 5.- DIMENSION b1 & c1 APPLY TO BASE METAL ONLY.
  - 6.- CONTROLLING DIMENSION : INCHES.
  - 7.- THERMAL PAD CONTOUR OPTIONAL WITHIN DIMENSIONS E,H1,D2 & E1
  - 8.- DIMENSION E2 X H1 DEFINE A ZONE WHERE STAMPING AND SINGULATION IRREGULARITIES ARE ALLOWED.
  - 9.- OUTLINE CONFORMS TO JEDEC TO-220, EXCEPT A2 (max.) AND D2 (min.) WHERE DIMENSIONS ARE DERIVED FROM THE ACTUAL PACKAGE OUTLINE.
  - 10.- LEADS AND DRAIN ARE PLATED WITH 100% Sn

Case Outline – D<sup>2</sup>pak – 5 leads

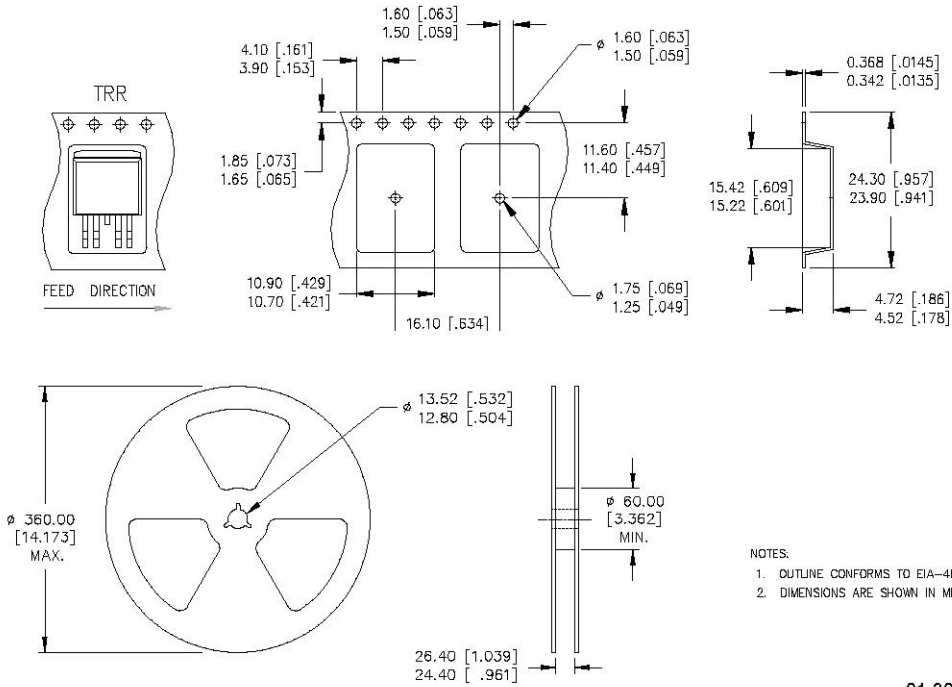


NOTES:

1. DIMENSIONING AND TOLERANCING AS PER ASME Y14.5M-1994
2. DIMENSIONS ARE SHOWN IN MILLIMETERS [INCHES].
3. DIMENSION D & E DO NOT INCLUDE MOLD FLASH. MOLD FLASH SHALL NOT EXCEED 0.127 [.005"] PER SIDE. THESE DIMENSIONS ARE MEASURED AT THE OUTMOST EXTREMES OF THE PLASTIC BODY AT DATUM H.
4. THERMAL PAD CONTOUR OPTIONAL WITHIN DIMENSION E, L1, D1 & E1.
5. DIMENSION b1 AND c1 APPLY TO BASE METAL ONLY.
6. DATUM A & B TO BE DETERMINED AT DATUM PLANE H.
7. CONTROLLING DIMENSION: INCH.
8. OUTLINE CONFORMS TO JEDEC OUTLINE TO-263BA.
9. LEADS AND DRAIN ARE PLATED : 100% Sn

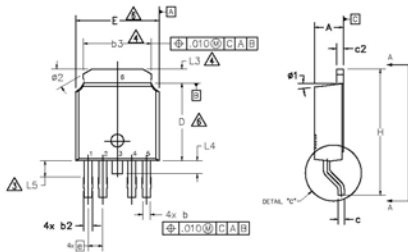
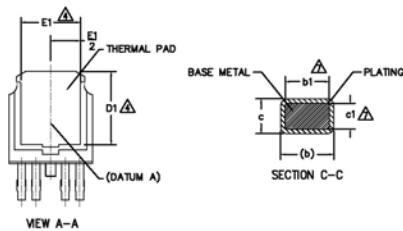
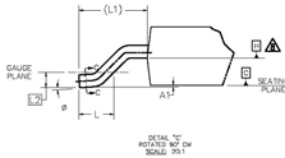
SYMBOL	DIMENSIONS				NOTES
	MILLIMETERS		INCHES		
	MIN.	MAX.	MIN.	MAX.	
A	4.08	4.83	.160	.190	4
A1	-	0.254	-	.010	
b	0.51	0.99	.020	.039	
b1	0.51	0.89	.020	.035	
c	0.38	0.74	.015	.029	4
c1	0.38	0.58	.015	.023	
c2	1.14	1.65	.045	.065	3
D	8.38	9.65	.330	.380	
D1	6.86	-	.270	-	
E	9.65	10.87	.380	.420	
E1	6.22	-	.245	-	3
e	1.70	BSC	.067	BSC	
H	14.61	15.85	.575	.625	3
L	1.78	2.79	.070	.110	
L1	-	1.68	-	.066	3
L2	-	1.78	-	.070	
L3	0.25	BSC	.010	BSC	3
L4	4.78	5.28	.188	.208	

## Tape and Reel – D<sup>2</sup>Pak – 5 leads



01-3071 00 / 01-3072 00

**Case Outline – Dpak – 5 leads**

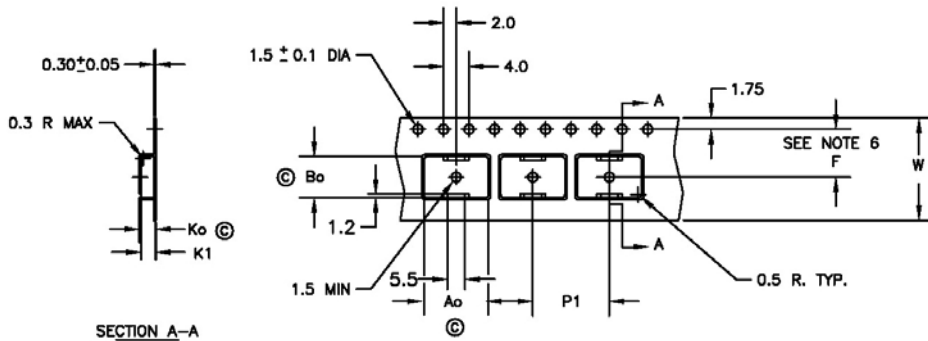


SYMBO L	DIMENSIONS				NOTES
	MILLIMETERS		INCHES		
	MIN.	MAX.	MIN.	MAX.	
A	2.18	2.39	.086	.094	
A1	—	0.13	—	.005	
b	0.51	0.89	.020	.035	2
b1	.051	0.84	.020	.033	
b3	4.95	5.46	.195	.215	2
c	0.46	0.61	.018	.024	
c1	0.41	0.56	.016	.022	2
c2	0.46	0.89	.018	.035	
D	5.97	6.22	.235	.245	3
D1	5.21	—	.205	—	
E	6.35	6.73	.250	.265	3
E1	4.32	—	.170	—	
e	1.14 BSC		.045 BSC		
H	9.40	10.41	.370	.410	
L	1.40	1.78	.055	.070	
L1	2.74 BSC		.108 REF.		
L2	0.51 BSC		.020 BSC		
L3	0.89	1.27	.035	.050	
L4	—	1.02	—	.040	
L5	1.14	1.52	.045	.060	
φ	0"	10"	0"	10"	
φ1	0"	15"	0"	15"	
φ2	28"	32"	28"	32"	

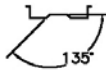
**NOTES:**

- 1.- DIMENSIONING AND TOLERANCING AS PER ASME Y14.5M-1994
- 2.- DIMENSIONS ARE SHOWN IN INCHES [MILLIMETERS].
- 3.- LEAD DIMENSION UNCONTROLLED IN L5.
- 4.- DIMENSION D1, E1, L3 & b3 ESTABLISH A MINIMUM MOUNTING SURFACE FOR THERMAL PAD.
- 5.- SECTION C-C DIMENSIONS APPLY TO THE FLAT SECTION OF THE LEAD BETWEEN .005 AND 0.10 [0.13 AND 0.25] FROM THE LEAD TIP.
- 6.- DIMENSION D & E DO NOT INCLUDE MOLD FLASH. MOLD FLASH SHALL NOT EXCEED .005 [0.13] PER SIDE. THESE DIMENSIONS ARE MEASURED AT THE OUTMOST EXTREMES OF THE PLASTIC BODY.
- 7.- DIMENSION b1 & c1 APPLIED TO BASE METAL ONLY.
- 8.- DATUM A & B TO BE DETERMINED AT DATUM PLANE H.
- 9.- OUTLINE CONFORMS TO JEDEC OUTLINE TO-252.
10. LEADS AND DRAIN ARE PLATED WITH 100% Sn

Tape & Reel – Dpak – 5 leads



SECTION A-A



$A_o = 10.5 \text{ mm}$   
 $B_o = 7.0 \text{ mm}$   
 $K_o = 2.8 \text{ mm}$   
 $K_1 = 2.4 \text{ mm}$   
 $F = 7.5 \text{ mm}$   
 $P_1 = 12.0 \text{ mm}$   
 $W = 16.0 \pm .3 \text{ mm}$

NOTES:

1. 10 SPROCKET HOLE PUNCH CUMULATIVE TOLERANCE  $\pm 0.02$
2. CAMBER NOT TO EXCEED 1mm IN 100mm
3. MATERIAL: CONDUCTIVE BLACK POLYSTYRENE
4.  $A_o$  AND  $B_o$  MEASURED ON A PLANE 0.3mm ABOVE THE BOTTOM OF THE POCKET
5.  $K_o$  MEASURED FROM A PLANE ON THE INSIDE BOTTOM OF THE POCKET TO THE TOP SURFACE OF THE CARRIER
6. POCKET POSITION RELATIVE TO THE SPROCKET HOLE MEASURED AS TRUE POSITION OF POCKET, NOT POCKET HOLE
7. VENDOR: (OPTIONAL)
8. MUST ALSO MEET REQUIREMENTS OF EIA STANDARD #EIA-481A, TAPING OF SURFACE-MOUNT COMPONENTS FOR AUTOMATIC PLACEMENT.
9. TOLERANCE TO BE MANUFACTURER STANDARD
10. SURFACE RESISTIVITY OF MOLDED MATL: MUST MEASURE LESS THAN OR EQUAL TO  $10^4$  OHMS PER SQUARE. MEASURED IN ACCORDANCE TO PROCEDURE GIVEN IN ASTM D-257 & ASTM D-991 (REF. C-9000 SPEC.)
11. TOTAL LENGTH PER REEL MUST BE 79 METERS
12. © CRITICAL DIMENSION

## Looking for pricing, stock, or lifecycle information?

Click below to explore more details on WIN SOURCE:

- [⊖ View \*\*IPS7081STRLPBF\*\* on WIN SOURCE](#)
- [⊖ \*\*Infinion Technologies\*\* Information](#)

## Optimize Your Supply Chain with WIN SOURCE Solutions

- ✓ Global Sourcing Solution
- ✓ Obsolete Management
- ✓ Cost Control Management
- ✓ Shortage Management
- ✓ Alternative Solution
- ✓ Excess Inventory Management