



**THE DATASHEET OF  
DF30FC-50DS-0.4V(81)**



Sep.1.2019 Copyright 2019 HIROSE ELECTRIC CO., LTD. All Rights Reserved.  
In case of consideration for using Automotive equipment / device which demand high reliability, kindly contact our sales window correspondents.

COUNT	DESCRIPTION OF REVISIONS	BY	CHKD	DATE	COUNT	DESCRIPTION OF REVISIONS	BY	CHKD	DATE
3	RE-H-06741	A.T	T.S	05.01.28					
1	DIS-H-001096	A.A		7.11.06.06.29					

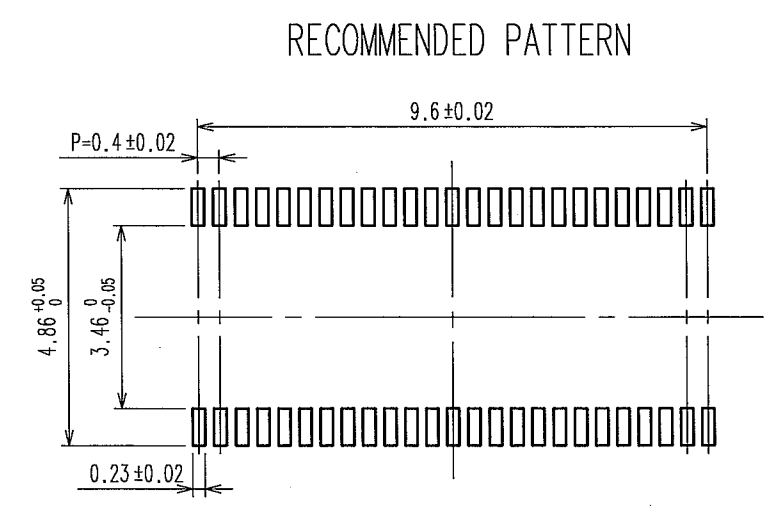
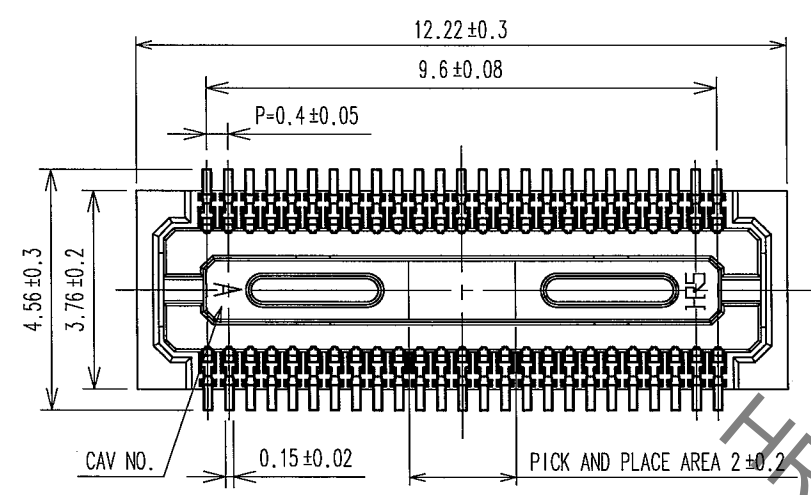

RECOMMENDED SOLDER PASTE: THICKNESS 120μm

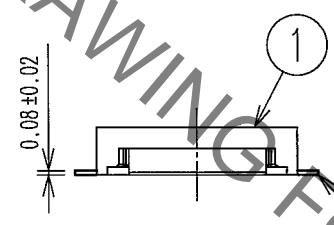
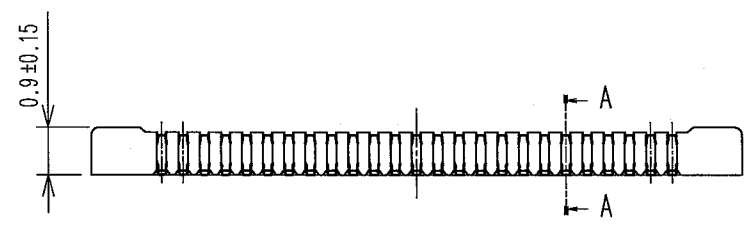

A-A(20:1)

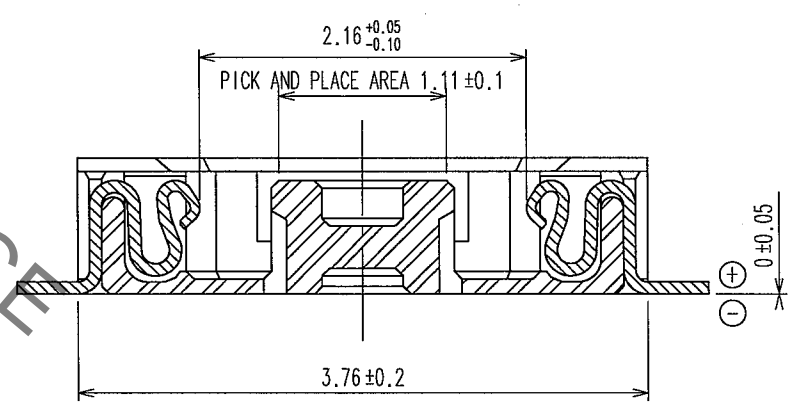

- NOTE 1. ALL LEADS CO-PLANARITY SHALL BE 0.1 MAX.  
 2. PER REEL : 5000 CONNECTORS.  
 3. AT THE BEGINNING OF THE REEL, 100 MM AT MIN SHALL BE EMPTY POCKETS.  
 AT THE END OF THE REEL, 160 MM AT MIN SHALL BE EMPTY POCKETS.  
 4. CONTACT PLATING SPECIFICATIONS.  
 CONTACT AREA : GOLD 0.05μm MIN.  
 SMT LEAD : GOLD 0.02μm MIN.  
 UNDERPLATING : NICKEL 1μm MIN.  
 (SURFACE : SEALING)

2	PHOSPHOR BRONZE	4	5	PS	PLASTIC REEL (BLACK)
1	LCP	UL94V-0, BLACK	4	POLYESTER	CLEAR(CAVER TAPE)
			3	PS	CLEAR(EMBOSSD CARRIER TAPE)
NO.	MATERIAL	FINISH, REMARKS	NO.	MATERIAL	FINISH, REMARKS
CODE NO. (OLD)		DRAWN	DESIGNED	CHECKED	APPROVED
		T.NISHI	K.MIDORIKAWA	S.TOMIOKA	S.TOMIOKA
		'04.06.11	'04.06.11	'04.06.11	'04.06.11
DRAWING NO.		PART NO.			
EDC3-303466-03		DF30FC-50DS-0.4V(81)			
SCALE		CODE NO.			
FREE		CL684-1114-8-81			
UNITS		HIROSE ELECTRIC CO., LTD			
mm					

Sep.1.2019 Copyright 2019 HIROSE ELECTRIC CO., LTD. All Rights Reserved.  
In case of consideration for using Automotive equipment / device which demand high reliability, kindly contact our sales window correspondents.

COUNT	DESCRIPTION OF REVISIONS	BY	CHKD	DATE	COUNT	DESCRIPTION OF REVISIONS	BY	CHKD	DATE

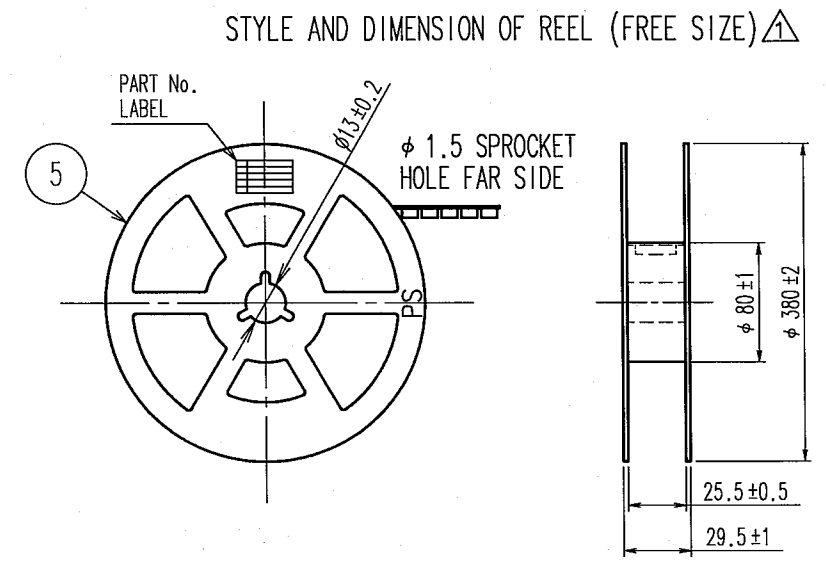
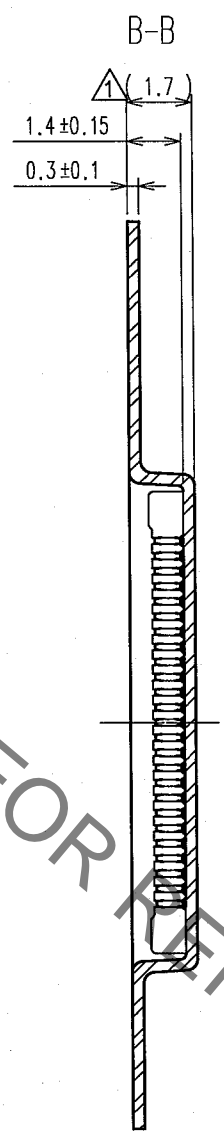
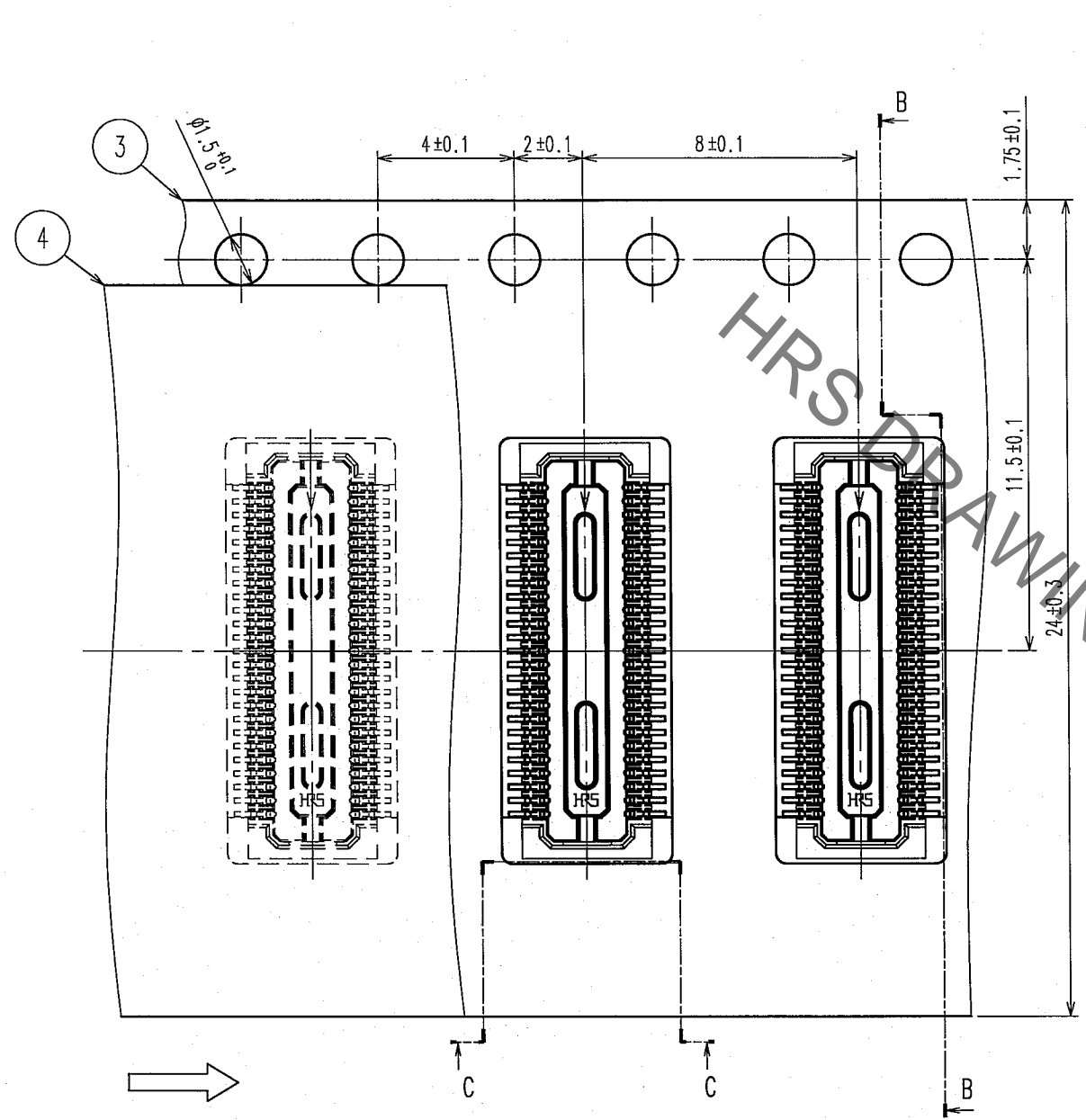

DETAIL OF PART NO. LABEL

SUPPLIER  
QUANTITY  
PART NO.  
CODE NO.  
DATE OF MANUFACTURED



生産月日	年 月 日
図番	CL684-1114-8-81
品名	DF30FC-50DS-0.4V(81)
納入数量	5000個
納入者	ヒロセ電機(株)

TO

CODE NO. (OLD)	DRAWN	DESIGNED	CHECKED	APPROVED	RELEASED
	T.NISHI	K.MIDORIKAWA	S.TOMIOKA	S.TOMIOKA	
	'04.06.11	'04.06.11	'04.06.11	'04.06.11	
SCALE	DRAWING NO.		PART NO.		
5 : 1	EDC3-303466-03		DF30FC-50DS-0.4V(81)		
UNITS	HRS HIROSE ELECTRIC CO., LTD		CODE NO.		2
mm			CL684-1114-8-81		

## Looking for pricing, stock, or lifecycle information?

Click below to explore more details on WIN SOURCE:

-  [View DF30FC-50DS-0.4V\(81\) on WIN SOURCE](#)
-  [Hirose Electric Co Ltd Information](#)

## Optimize Your Supply Chain with WIN SOURCE Solutions

-  Global Sourcing Solution
-  Obsolete Management
-  Cost Control Management
-  Shortage Management
-  Alternative Solution
-  Excess Inventory Management