



THE DATASHEET OF XPC01DTC



XPC/XPCL and XPX/XPXL Series

Uncompensated/Compensated and Compensated Calibrated Silicon Pressure Sensors

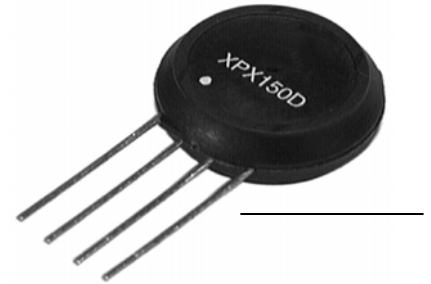

DESCRIPTION

The XPC/XPCL and XPX/XPXL Series sensors integrate silicon micromachined sensing technology, temperature compensation, and calibration in a complete family of low-cost packages. This series offers a cost-effective solution for design requirements.

These piezoresistive pressure sensors use micromachined silicon chips mounted on ceramic and protected with a plastic cap. Several tube arrangements with nylon housings are available for various pressure applications.

FEATURES

- Low cost, small size
- Temperature compensated
- Zero and span calibrated
- Millivolt output
- Differential, gage and absolute pressure
- Constant voltage excitation
- High impedance - low current

On devices of 5 psi and above, the top side of the chip is protected against humidity by a Silgel® coating.

Although the sensors are designed for use with noncorrosive, nonionic pressure media, they accommodate many gases that are used in medical applications.

POTENTIAL APPLICATIONS

- Medical applications
- Applications requiring small size
- Applications requiring vacuum and positive pressure reference or both

XPC/XPCL and XPX/XPXL Series

ELECTRICAL SPECIFICATIONS

Characteristic	XPC/XPCL at 12 Vdc, 25 °C [77 °F]				XPX/XPXL at 5 Vdc, 25 °C [77 °F]			
	Min.	Typ.	Max.	Unit	Min.	Typ.	Max.	Unit
Excitation voltage	3.0	12.0	16.0	Vdc	3.0	5.0	12.0	Vdc
Null	-1.0	0	1.0	mV	-50	0	50	mV
Offset temperature shift ⁽¹⁾ 0 °C to 25 °C [32 °F to 77 °F] 25 °C to 70 °C [77 °F to 158 °F]	-	-	±1.0	mV	-	±0.5	-	mV
Full scale temperature shift ⁽¹⁾ 0 °C to 25 °C [32 °F to 158 °F] 25 °C to 70 °C [77 °F to 158 °F]	-	-	±2	PPM/°C	-	-2200	-	PPM/°C
Linearity, hysteresis error ⁽²⁾	-	0.25	1.0	% span	-	0.25	1.0	% span
Input resistance	5.0	-	-	kOhm	5.0	-	-	kOhm
Output resistance	-	3.0	-	kOhm	-	3.0	-	kOhm
Operating temperature	-25 [-13]	-	85 [185]	°C [°F]	-25 [-13]	-	85 [185]	°C [°F]
Storage temperature	-40 [-40]	-	125 [257]	°C [°F]	-40 [-40]	-	125 [257]	°C [°F]
Common mode pressure	-	-	50	psi	-	-	50	psi
Weight	-	2	-	g	-	2	-	g

Notes:

- Shift is relative to 25 °C [77 °F].
- Measured at 1/2 full scale rated pressure using BFSL.

ABSOLUTE OUTPUT

FS Pressure	XPC at 12 Vdc, 25 °C [77 °F] Output Full Scale Span (mV)			XPX at 5 Vdc, 25 °C [77 °F] Output Full Scale Span (mV)			Overpressure (psi) Max.
	Min.	Typ.	Max.	Min.	Typ.	Max.	
5 psi	57	60	63	112	168.5	225	15
15 psi	85	90	95	168	253	338	45
30 psi	85	90	95	168	253	338	90
60 psi	85	90	95	189	263.5	338	180
100 psi	95	100	105	210	295	380	250

GAGE/DIFFERENTIAL⁽¹⁾ OUTPUT

FS Pressure	XPC/XPCL at 12 Vdc, 25 °C [77 °F] Output Full Scale Span (mV)			XPX/XPXL at 5 Vdc, 25 °C [77 °F] Output Full Scale Span (mV)			Overpressure (psi) Max.
	Min.	Typ.	Max.	Min.	Typ.	Max.	
4 in H ₂ O	23	25	27	50	68	86	3
10 in H ₂ O	19	20	21	40	78.5	112	3
1 psi	17	18	19	40	75	110	3
5 psi	57	60	63	112	168.5	225	15
15 psi	85	90	95	168	253	338	45
30 psi	85	90	95	168	253	338	90
60 psi	85	90	95	189	263.5	338	180
100 psi	95	100	105	210	295	380	250
150 psi	85	90	95	187	262.5	338	250

Note:

- Differential common mode pressure should not exceed 50 psi.

MOUNTING DIMENSIONS (For reference only: mm (in.))

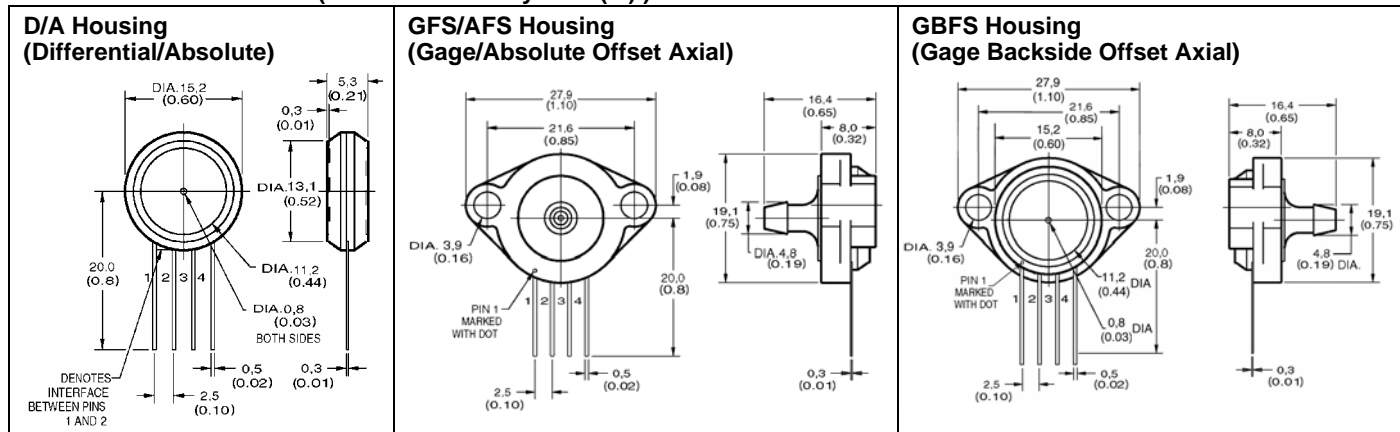

Uncompensated/Compensated and Compensated Calibrated Silicon Pressure Sensors

MOUNTING DIMENSIONS (For reference only: mm (in.))

**GF/AF Housing
(Gage/Absolute Axial)**

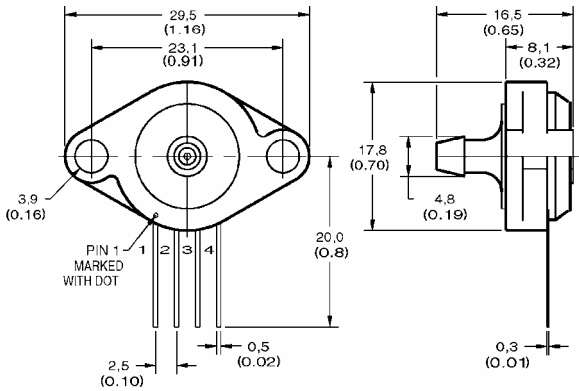

**DF Housing
(Differential Axial)**

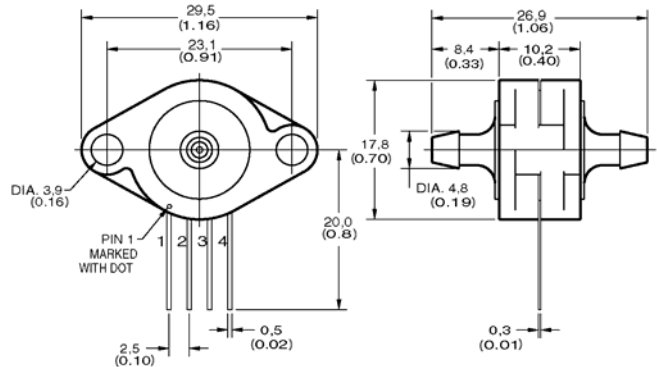

**GBF Housing
(Gage Backside Axial)**

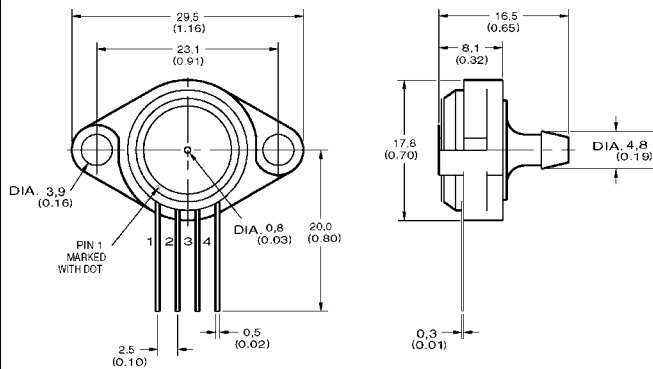

**GT/AT Housing
(Gage/Absolute Radial)**

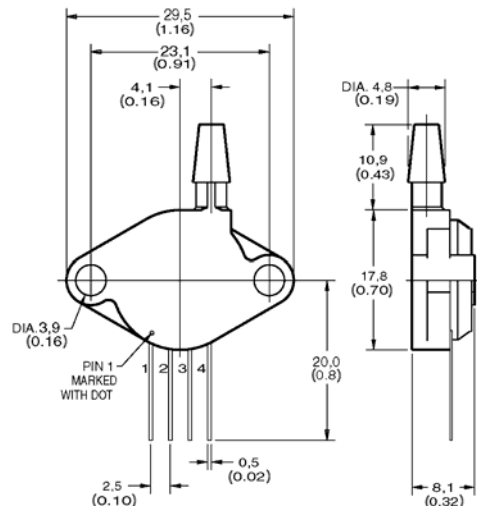

**GBT Housing
(Gage Backside Radial)**

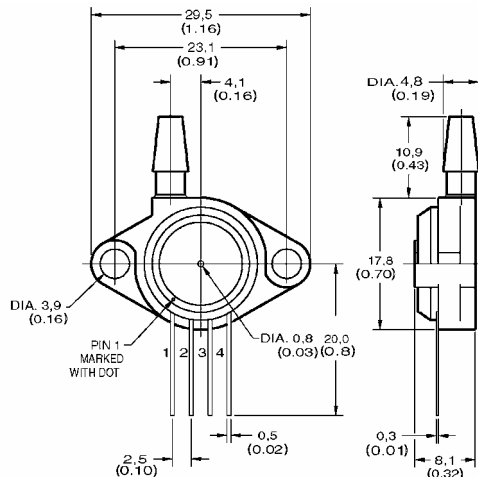

**DT Housing
(Differential Radial)**

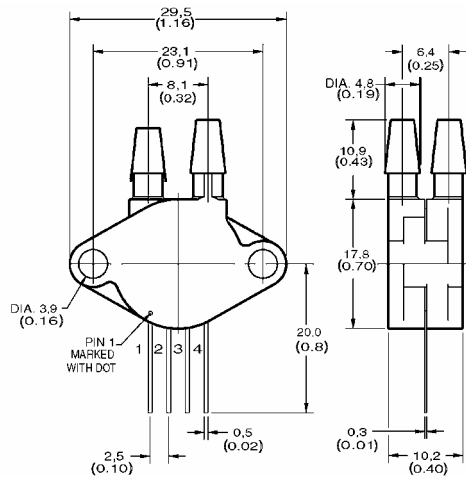

EQUIVALENT CIRCUIT

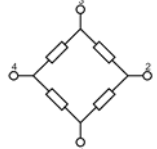
	<p>Pinout</p> <ol style="list-style-type: none"> 1. -V Excitation 2. + Output Signal 3. +V Excitation 4. - Output Signal 	<p>Media compatibility: Clean, dry gases only.</p> <p>P1 Port: Media must be compatible with epoxy-based adhesive and silicon gel.</p> <p>P2 Port: Media must be compatible with nylon housing, epoxy-based adhesive and silicon.</p>
---	---	--

ORDER GUIDE⁽¹⁾

<p>Series</p> <p>XPC</p> <p>XPX - uncompensated and uncalibrated, mV XPC - compensated and calibrated, mV</p>	<p>L</p> <p>04</p> <p>G</p> <p>B</p> <p>F</p> <p>C</p>	<p>Accuracy Grade</p> <p>(XPC, XPCL only) C - Commercial H - High Accuracy</p>
<p>Pressure Measurement</p> <p>L - Low Pressure (in H₂O) No Character - Indicates Pressure (psi)</p>	<p>Pressure Range</p> <p>04 in H₂O, 10 in H₂O 01, 05, 15, 30, 60, 100, 150 psi</p>	<p>Port Operation²</p> <p>B - Backside</p> <p>G - Gage D - Differential A - Absolute ≥ 5 psi</p>
<p>Port Option</p> <p>F - Axial T - Radial FS - Offset Axial²</p>		

Notes:

1. Not all combinations may be available. Contact Honeywell representative for details.
2. Option available in ported gage version only.

⚠ WARNING

PERSONAL INJURY

DO NOT USE these products as safety or emergency stop devices or in any other application where failure of the product could result in personal injury.

Failure to comply with these instructions could result in death or serious injury.

WARRANTY/REMEDY

Honeywell warrants goods of its manufacture as being free of defective materials and faulty workmanship. Honeywell's standard product warranty applies unless agreed to otherwise by Honeywell in writing; please refer to your order acknowledgement or consult your local sales office for specific warranty details. If warranted goods are returned to Honeywell during the period of coverage, Honeywell will repair or replace, at its option, without charge those items it finds defective. **The foregoing is buyer's sole remedy and is in lieu of all other warranties, expressed or implied, including those of merchantability and fitness for a particular purpose. In no event shall Honeywell be liable for consequential, special, or indirect damages.**

While we provide application assistance personally, through our literature and the Honeywell web site, it is up to the customer to determine the suitability of the product in the application.

Specifications may change without notice. The information we supply is believed to be accurate and reliable as of this printing. However, we assume no responsibility for its use.

Sensing and Control
Honeywell
1985 Douglas Drive North
Minneapolis, MN 55422
www.honeywell.com/sensing

⚠ WARNING

MISUSE OF DOCUMENTATION

- The information presented in this product sheet is for reference only. Do not use this document as a product installation guide.
- Complete installation, operation, and maintenance information is provided in the instructions supplied with each product.

Failure to comply with these instructions could result in death or serious injury.

SALES AND SERVICE

Honeywell serves its customers through a worldwide network of sales offices, representatives and distributors. For application assistance, current specifications, pricing or name of the nearest Authorized Distributor, contact your local sales office or:

E-mail: info.sc@honeywell.com

Internet: www.honeywell.com/sensing

Phone and Fax:

Asia Pacific +65 6355-2828
+65 6445-3033 Fax
Europe +44 (0) 1698 481481
+44 (0) 1698 481676 Fax
Latin America +1-305-805-8188
+1-305-883-8257 Fax
USA/Canada +1-800-537-6945
+1-815-235-6847
+1-815-235-6545 Fax

Looking for pricing, stock, or lifecycle information?

Click below to explore more details on WIN SOURCE:

 [View XPC01DTC on WIN SOURCE](#)

 [Honeywell Information](#)

Optimize Your Supply Chain with WIN SOURCE Solutions

-  Global Sourcing Solution
-  Obsolete Management
-  Cost Control Management
-  Shortage Management
-  Alternative Solution
-  Excess Inventory Management