



# THE DATASHEET OF OP522



# Silicon Phototransistor in Miniature SMT Package

## OP522

- High Photo Sensitivity
- Fast Response Time
- 1206 Package Size with Internal Lens

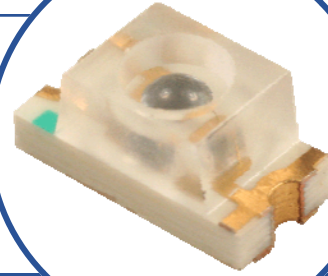

The OP522 is an NPN silicon phototransistor mounted in a miniature SMT package. The device incorporates an integral molded lens which enables a narrow acceptance angle and higher collector currents than devices without lenses. This device is packaged in a 1206 size chip carrier that is compatible with most automated mounting equipment. The OP522 is mechanically and spectrally matched to the OP250 series infrared LEDs.

## Applications

- Non-Contact Position Sensing
- Datum detection
- Machine automation
- Optical encoders

Relative Response vs. Wavelength

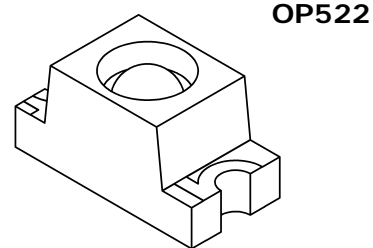
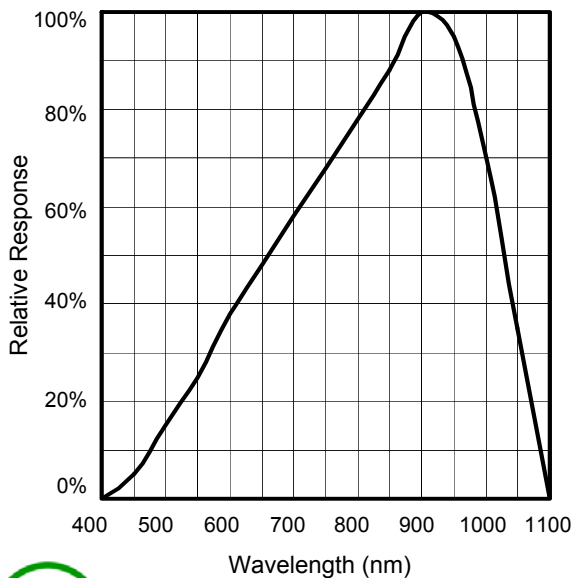

**RoHS**

OPTEK reserves the right to make changes at any time in order to improve design and to supply the best product possible.

### Absolute Maximum Ratings

$T_A = 25^\circ\text{C}$  unless otherwise noted

Storage Temperature Range	-40° C to +85° C
Operating Temperature Range	-25° C to +85° C
Lead Soldering Temperature	260° C <sup>(1)</sup>
Collector-Emitter Voltage	30 V
Emitter-Collector Voltage	5 V
Collector Current	20 mA
Power Dissipation	75 mW <sup>(2)</sup>

Notes:

- Solder time less than 5 seconds at temperature extreme.
- De-rate linearly at 2.17 mW/° C above 25° C.

### Electrical Characteristics ( $T_A = 25^\circ\text{C}$ unless otherwise noted)

SYMBOL	PARAMETER	MIN	TYP	MAX	UNITS	CONDITIONS
$I_{C(ON)}$	On-State Collector Current	0.5			mA	$V_{CE} = 5.0\text{V}$ , $E_e = 5.0\text{mW/cm}^2$ <sup>(3)</sup>
$V_{CE(SAT)}$	Collector-Emitter Saturation Voltage			0.4	V	$I_C = 100\mu\text{A}$ , $E_e = 2.0\text{mW/cm}^2$ <sup>(3)</sup>
$I_{CEO}$	Collector-Emitter Dark Current			100	nA	$V_{CE} = 5.0\text{V}$ , $E_e = 0$ <sup>(4)</sup>
$V_{(BR)CEO}$	Collector-Emitter Breakdown Voltage	30			V	$I_C = 100\mu\text{A}$
$V_{(BR)ECO}$	Emitter-Collector Breakdown Voltage	5			V	$I_E = 100\mu\text{A}$
$t_r, t_f$	Rise and Fall Times		15		$\mu\text{s}$	$I_C = 1\text{mA}$ , $R_L = 1\text{K}\Omega$

- Light source is an unfiltered GaAs LED with a peak emission wavelength of 935nm and a radiometric intensity level which varies less than 10% over the entire lens surface of the phototransistor being tested.
- To Calculate typical collector dark current in  $\mu\text{A}$ , use the formula  $I_{CEO} = 10^{(0.04 T_A - 3/4)}$  where  $T_A$  is the ambient temperature in ° C.

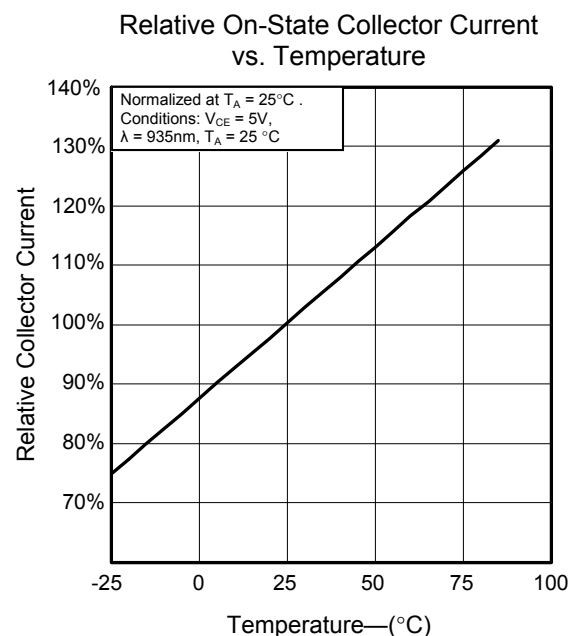
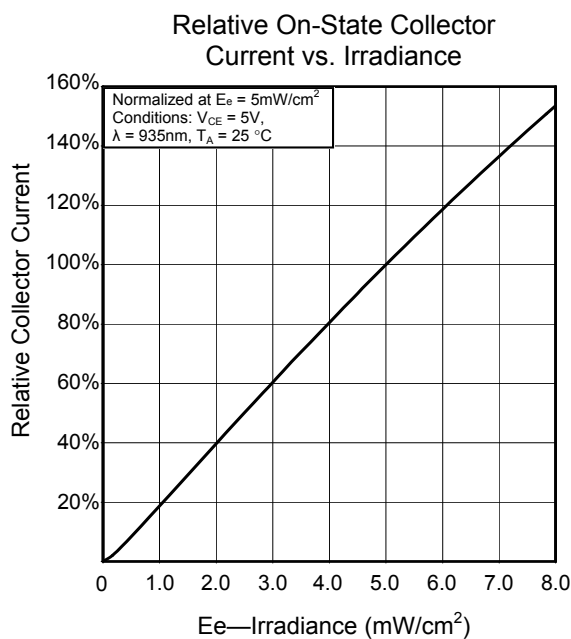

OPTEK reserves the right to make changes at any time in order to improve design and to supply the best product possible.

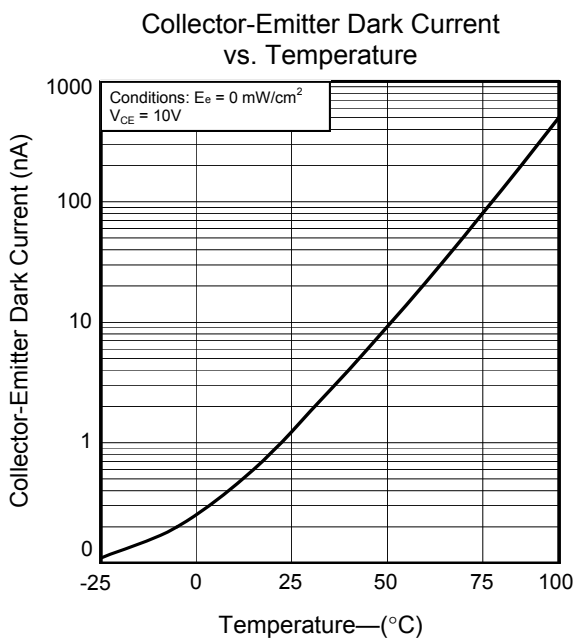
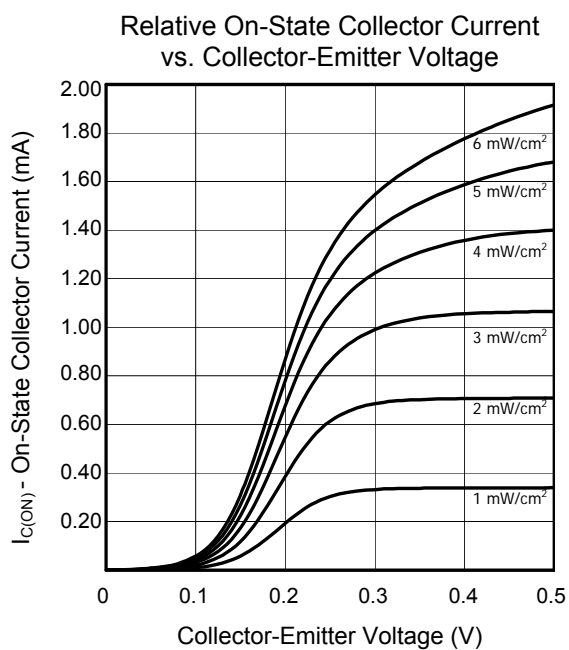
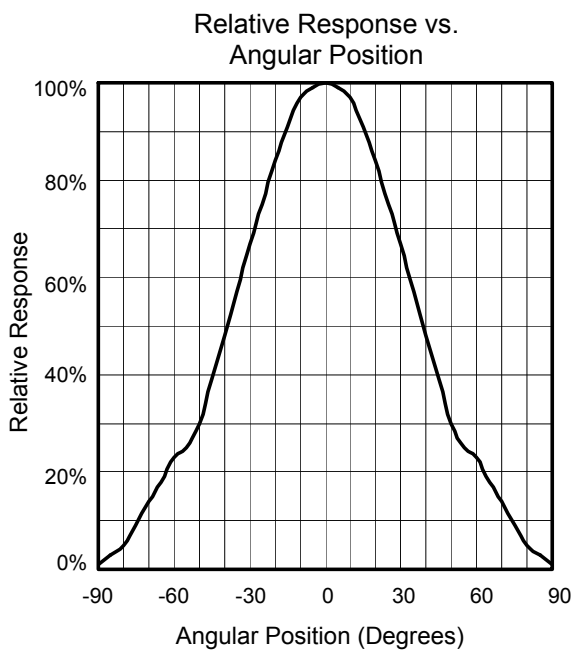

OPTEK reserves the right to make changes at any time in order to improve design and to supply the best product possible.

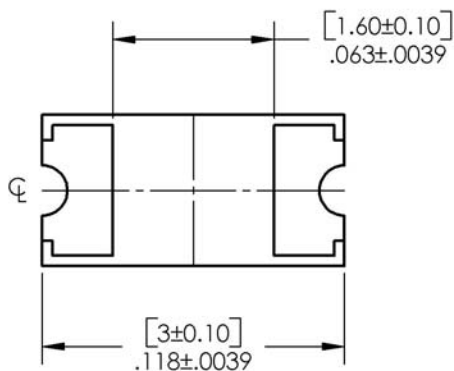
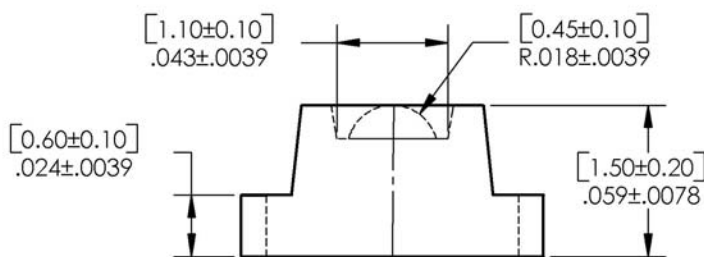
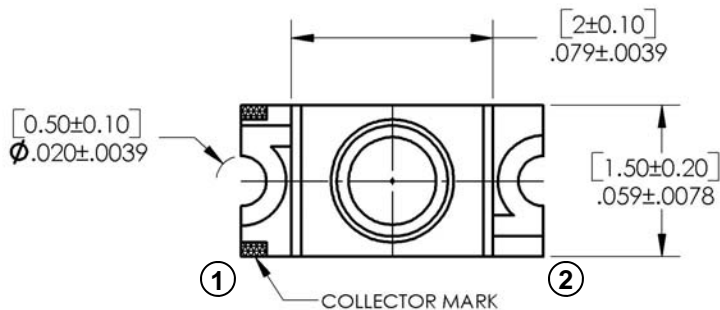

DIMENSIONS ARE IN INCHES AND [MILLIMETERS].

### RECOMMENDED SOLDER PADS

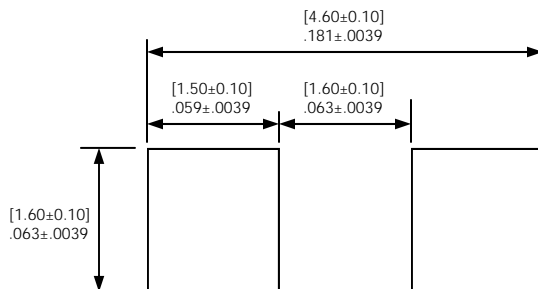

PIN	FUNCTION
1	Collector
2	Emitter

OPTEK reserves the right to make changes at any time in order to improve design and to supply the best product possible.

## Looking for pricing, stock, or lifecycle information?

Click below to explore more details on WIN SOURCE:

 [View OP522 on WIN SOURCE](#)

 [TT Electronics](#) Information

## Optimize Your Supply Chain with WIN SOURCE Solutions

-  Global Sourcing Solution
-  Obsolete Management
-  Cost Control Management
-  Shortage Management
-  Alternative Solution
-  Excess Inventory Management