



**THE DATASHEET OF
CAB500-C/SP5**



AUTOMOTIVE CURRENT TRANSDUCER – FLUXGATE TECHNOLOGY CAB500-C / SP5



Introduction

The CAB family is best suited for battery monitoring application where high accuracy and very low offset are required.

It offers galvanic isolation between the primary circuit (high voltage) and the secondary circuit (12V system).

Automotive applications

- Hybrid and electric vehicle battery pack
- Conventional lead-acid batteries
- Accurate current measurement for battery management applications (SOC, SOH, SOF, etc...)

Features

- Transducer using Fluxgate technology
- Unlimited over-current capability
- Panel mounting
- Unipolar +12V battery power supply
- Output signal: High speed CAN (500kpbs)
- Configurable internal digital low-pass frequency filter
- Configurable CAN speed
- Configurable CAN ID

Principle of CAB Family

A low-frequency fluxgate transducer is made of a wound core which saturates under low induction.

A current chopper switches the winding's current to saturate the magnetic core alternatively at $\pm B_{max}$ with a fixed frequency.

Fluxgate transducers use the change of the saturation's point symmetry to measure the primary current.

Due to the principle of switching the current, all offsets (electric and magnetic) are cancelled.

Special feature(s)

- Connector type: Tyco AMP 1473672-1

Advantages

- Offset below 10mA
- High overall accuracy
 - 0.1% error at room temperature (Typ.)
 - 0.5% error over temperature range (± 35)
- Full galvanic separation

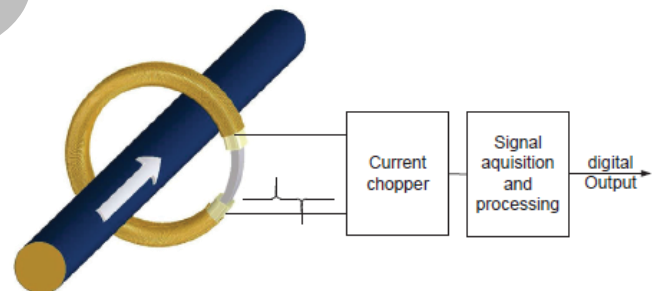

Dimensions CAB500-C series (in mm)

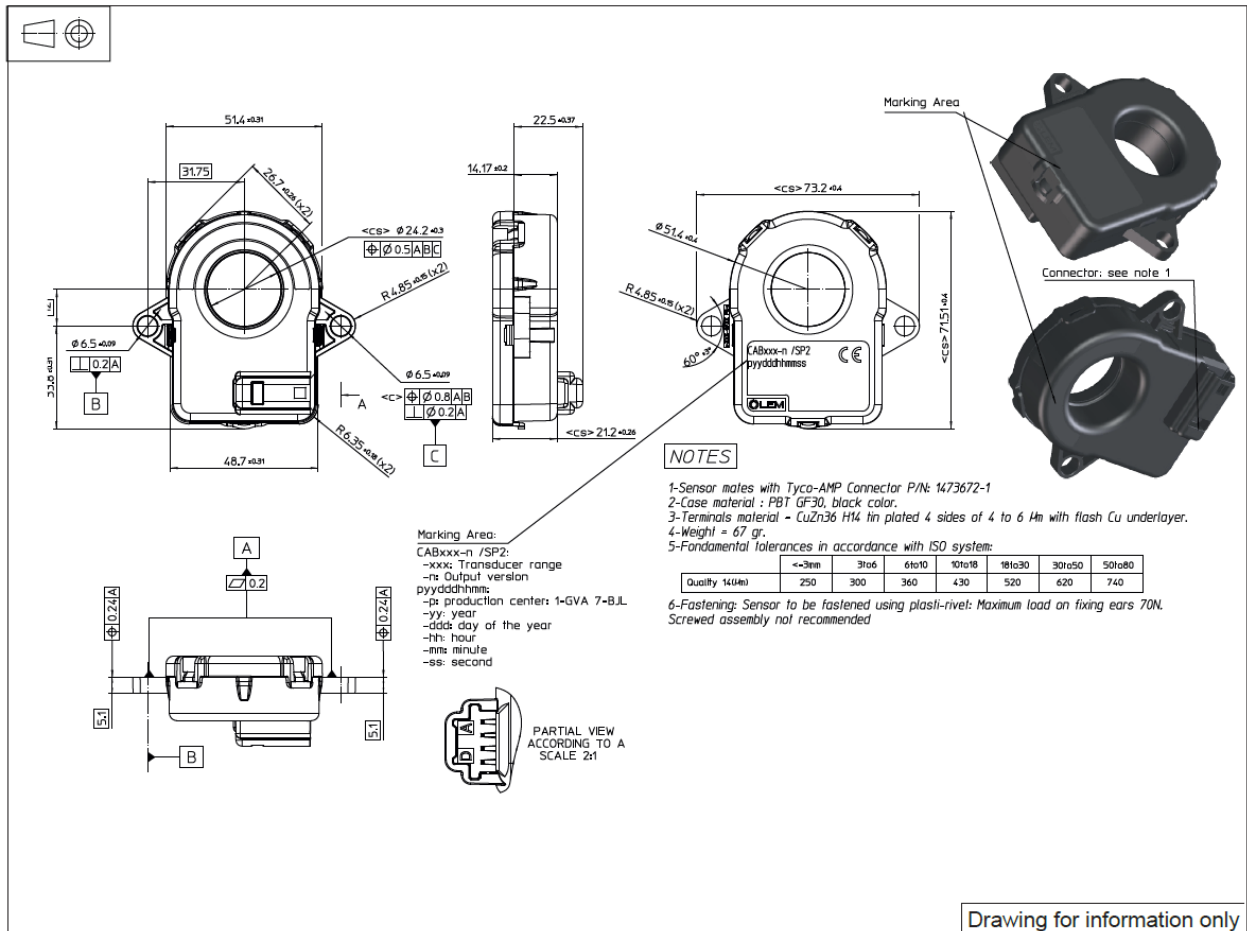

Mechanical characteristics

- Plastic case PBT GF 30
- Magnetic core Nanocrystallin
- Mass 67 g
- Electrical terminal coating Tin plated

Mounting recommendation

- Connector type Tyco-AMP P/N: 1 473672-1

Connection

Pin Out	
A	CAN-L
B	CAN-H
C	GND
D	U_c

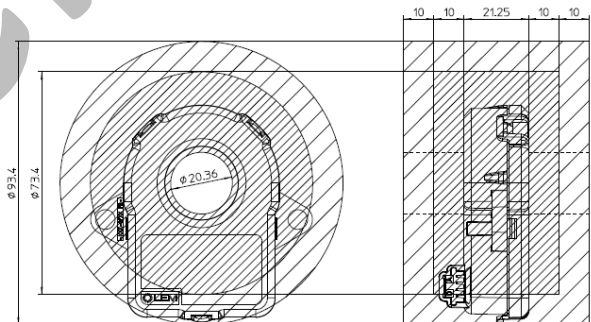

- Forbidden busbar area (Accuracy not guaranteed)
- Not recommended busbar area (Accuracy should be confirmed)

Forbidden areas – External Field Influences

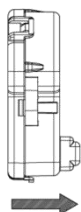

I_p (positive primary current direction)

CAB500-C / SP5

Absolute maximum ratings (not operating)

Parameter	Symbol	Unit	Specification		Conditions
Load-dump over-voltage	U_C	V	32		400ms
Over-voltage	U_C	V	24		1 minute
Reverse polarity	U_C	V	-50		1 minute
Minimum power supply	U_C	V	6		continuous, not measuring
Maximum power supply	U_C	V	18		continuous, not measuring
Creepage distance	d_{CP}	mm	7.2		
Clearance	d_{CI}	mm	6.95		
Rms voltage for AC insulation test	U_d	kV	2.5		50Hz, 1 min
Insulation resistance	R_{IS}	M Ω	500		500 V-ISO 16750-2
IP Level			IP41		

Characteristics in nominal range

Parameter	Symbol	Unit	Specification			Conditions
			Min	Typical	Max	
Electrical Data						
Supply voltage ¹⁾	U_C	V	8	13.5	16	
Current consumption @Ip = 0A	I_C	mA		30	40	@ $U_C = 13.5V$, CAN acknowledge
Current consumption @Ip = 500A	I_C	mA		140	150	@ $U_C = 13.5V$, CAN acknowledge
Ambient operating temperature	T_A	°C	-40		85	Temperature range with accuracy guaranteed +/-3 sigma
Performance Data						
Primary nominal DC or current rms	I_{PN}	A	-500		500	
Current clamping value		A	-530		530	
Voltage clamping value max		V		17.9		When U_C increases
		V		17.1		When U_C decreases
Voltage clamping value min		V		7.2		When U_C increases
		V		7.6		When U_C decreases
Linearity error	el	%		0.1		At room temperature
Gain drift		ppm/°C		70		
Output noise		mA		±10		
Frequency bandwidth ²⁾	BW	Hz		100		depends on the filter implemented (2)
Power up time		ms		150		
Setting time after over load		ms		20		

1. Performances are considered with average value over 10 CAN frames (100ms)
2. Bandwidth depends on emission period of the frame without digital filter

CAB500-C / SP5

Accuracy - Enhanced Performances in Typical Application

PHEV and EV systems may use different technologies of batteries. One very important parameter that may influence the stability of the SOC is the temperature.

The battery temperature affects vehicle performances, reliability, safety and life-cycle cost.

The CAB500-C family is qualified between -40°C to 85°C but the sensor shows a better accuracy in a restricted temperature range in order to deliver a very accurate current measurement.

As shown in the picture below, the recommended and desired operating temperature range is between 15°C to 35°C , in this range the CAB500-C family has a very good accuracy, please refer to the table 1

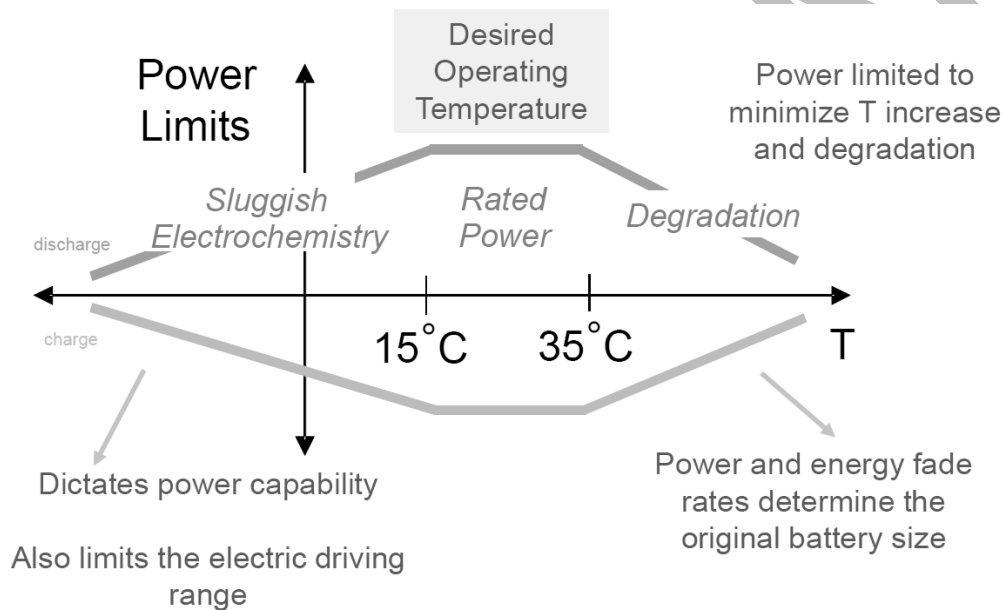

Figure 1 – Temperature impacts for battery life

Absolute Accuracy Table

Operating parameter valid for $T_A = -40^{\circ}\text{C}$ to $+85^{\circ}\text{C}$ & $11\text{V} < V_{CC} < 15\text{V}$

Primary Current	Symbol	Unit	Temperature					
			-40°C	0°C	15°C	25°C	55°C	85°C
100A	X_G	%	0.5	0.4	0.3	0.4	0.5	
350A								
450A								
500A								

Table 1 – Accuracy Table

- (1) All the parameters expressed in the table are determined during initial characterization and given at $\pm 3\sigma$
- (2) The accuracy of the sensor is guaranteed in the conditions given in the application notes ANE_120504 & ANE_14032017

CAB500-C / SP5

Global Accuracy Graph

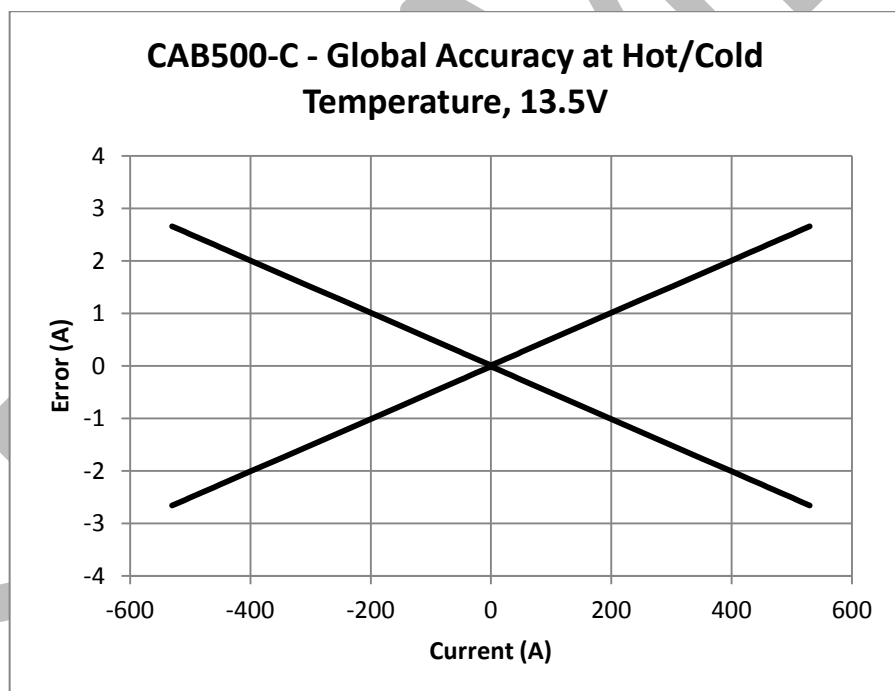
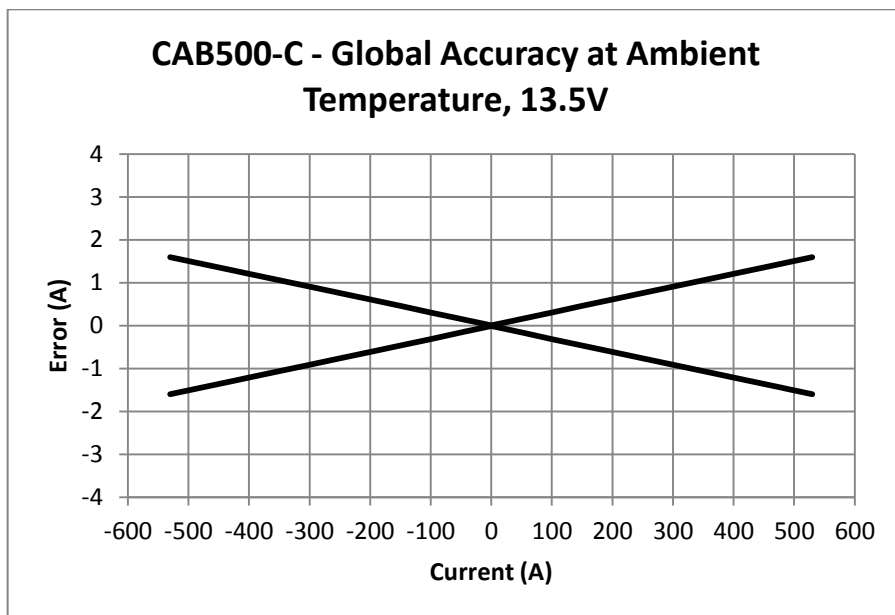

External Magnetic Field Influences

The CAB500-C family uses a very accurate technology and offers to the customer the current measurement needed to the application.

In order to respect this accuracy, some conditions must be respected during the design of the environment of the sensor:

- Primary busbar centering
- Busbar shape
- Contactors position

LEM's recommendations can be found in the application notes available on request.

CAB500-C / SP5

CAN output specification

- CAN protocol 2.0B
- Bit order: big endian (Motorola)
- CAN oscillator tolerance: 0.27%
- No sleep capability
- 120 ohm termination resistor to be added externally, internal CAN impedance = 2.4kohm

Message Description	CAN ID	Name	Data Length (Nb bytes)	Type of frame	Type of frame	Message launch type	Signal Description	Start bit	End bit
Return Current <i>I_p</i> (mA)	0x3C2	CAB500_IP	8	Standard	Cyclic 10ms cycle	<i>I_p</i> Value: 8000000H=0mA 7FFFFFFFH=-1mA 8000001H=1mA	IP_VALUE	0	31
						Error Info (1bit) 0=Normal 1=Failure	ERROR_INDICATION	32	32
						CSM-FAIL (7bits)	ERROR_INFO	33	39
						(24bits) CAB500	SENSOR_NAME	40	63

Error Management

Failure Mode	<i>I_p</i> Value	Error Indication	Error Information
Memory Error	0xFFFFFFFF	1	0x40
Overcurrent Detection <i>I_p</i> > 580A	0xFFFFFFFF	1	0x41
Fluxgate has no oscillation for more than 20ms	0xFFFFFFFF	1	0x42
Clock derivation	0xFFFFFFFF	1	0x44
Supply voltage is out of range	0xFFFFFFFF	1	0x46
Hardware default <i>ADC channel</i>	0xFFFFFFFF	1	0x47
New Data not available	0xFFFFFFFF	1	0x49
Hardware default <i>DAC Threshold</i>	0xFFFFFFFF	1	0x4A
Hardware default <i>Reference voltage</i>	0xFFFFFFFF	1	0x4B

Applicable standards

Test	Test standard	Procedure
Environmental test		
Shipping/Storage Temperature Exposure	ISO16750-4	164hrs, -40°C / + 85°C, power off, slope 0.6°C/min
Low Temperature Operating Endurance		120hrs, -40°C, power on
High Temperature Operating Endurance		85°C, 4752hrs, power on characterization before and after test only at 25°C and Vc nom
Powered Thermal Cycle Endurance	ISO16750-4	540 cycles/100min: -40°C (20min), +85°C (20min), slope 4°C/min : 900hrs characterization before and after test only at 25°C and Vc nom
Thermal Shock		-40°C (20 min soak) / 85°C (20 min soak) , 1000 cycles, with connectors => 667h (28 days)
Thermal Humidity Cycle	IEC 60068-2-38	240hrs, -10°C /+65°C , 93% humidity characterization before and after test only at 25°C and Vc nom
High Temperature and Humidity Endurance	IEC60068-2-67	85°C, 85% humidity, 1000hrs characterization before and after test only at 25°C and Vc nom Performance after test : offset<20mA, Global error < 3000mA
Vibration		Class 1 5 Hz to 1000 Hz (table 6-10), 20h / axis, 3 axis+ -40°C /+85°C during 8 hours and 25°C during 12h. (Fig.6-2) Characterization before and after test only at 25°C and Vcnom
Mechanical Shock	ISO16750-3	500m/s ² , 10 each direction (60 total) Half sine pulse Characterization before and after test only at 25°C and Vcnom
Package Drop		With final packaging 1m, 1 bottom, 4 bottom edge, 4 bottom corner => total 9 drops. 1 meter on concrete floor.
Handling Drop	ISO16750-3	1 fall in one direction for each sensor, from 1 meter on concrete floor. characterization before and after test only at 25°C and Vc nom
Dust (and other solid intrusion)	ISO20653	IP category: 4
Water Intrusion	ISO20653	IP category: 1
Dew formation test	IEC60068-2030	
Mixed Flowing Gas	IEC60068-2-60	
Salt Fog	ISO16750-4	96h @ 35°C 5% of salt water solution characterization before and after test only at 25°C and Vc nom
Chemical exposure - outside cabin compartment	ISO16750-5	24h / fluid; see PV test report for list of fluids

Test	Test standard	Procedure
EMC test		
CISPR 25 Conducted RF Emissions-Voltage on Supply Lines	CISPR25	Narrow band : 0.15 to 108 (MHz) Wide band : 0.15 to 200 (MHz)
CISPR 25 Conducted RF Emissions-Current on all Lines in Harness	CISPR25	Narrow band : 0.15 to 108 (MHz) Wide band : 0.15 to 200 (MHz)
CISPR 25 Radiated Emissions	CISPR25	30 to 1000 (MHz)
Bulk Current Injection (BCI) Test	ISO 11452-4	According to ISO 11452-4
ALSE with a Ground Plane	ISO 11452-2	According to ISO 11452-2
Transient Disturbances Conducted along Supply Lines	ISO 7637-2	According to ISO 7637-2
Transient Disturbances Conducted along I/O or Sensor Lines	ISO 7637-3	According to ISO 7637-3
Handling Test	ISO10605	Test method: IEC 61000-4-2 (2008) pins: +/-4kV case: +/-8kV
Operating Test	IEC 61000-4-2	Test method: IEC 61000-4-2 (2008) Indirect contact discharge: +/-8kV Air discharge: +/-20kV
Impulse Noise Test		+/-2kV noise simulator, on each lines
Fast Transient Noise Test		+/-2kV fast transient simulator, on each lines



SPEC

Test	Test standard	Procedure
Electrical test		
Supply Voltage Range		8V to 16V; from -40°C to 105°C
Supply Voltage Ripple	SAE J1113-2	According to SAE J1113-2
Supply Voltage Drop Out		Supply voltage drop from 11V to 0V and return to 11V. Drop duration increase from 10us to 1ms (sensor fonctionnal) and from 1ms to 2s (sensor not damaged)
Supply Voltage Dips		Supply voltage dips from 11V to dip voltage and return to 11V. Dip voltage are 5.5V, 5V, 4.5V, 4V, 3.5V and 3V. Dips duration for each levels are 100us-1ms (sensor fonctionnal) and 1ms-500ms (sensor not damaged)
Slow decreases and increase	ISO 16750-2 (2004)	According to ISO 16750-2 (2004)
Defective Regulation (Full-Fielded Alternator)		24V, 1 minute
Jump Start		18V, 60 minutes, @65°C
Load Dump		32V, 400ms; 5 pulses
Reverse Supply Voltage	ISO16750-2	-16V, 1 minute
Immunity to Short Circuits in the Supply Voltage Input and Load Output Lines		
Immunity to Short Circuits in I/O Signal Lines		

SPECIFICATION

Looking for pricing, stock, or lifecycle information?

Click below to explore more details on WIN SOURCE:

-  [View CAB500-C/SP5 on WIN SOURCE](#)
-  [LEM USA Inc. Information](#)

Optimize Your Supply Chain with WIN SOURCE Solutions

-  Global Sourcing Solution
-  Obsolete Management
-  Cost Control Management
-  Shortage Management
-  Alternative Solution
-  Excess Inventory Management