



**THE DATASHEET OF  
DF1760U**





**PCM1760P/U**  
**DF1760P/U**

## Multi-Bit Enhanced Noise Shaping 20-Bit ANALOG-TO-DIGITAL CONVERSION SYSTEM

### FEATURES

- **DUAL 20-BIT MONOLITHIC MODULATOR (PCM1760) AND MONOLITHIC DECIMATING DIGITAL FILTER (DF1760)**
- **HIGH PERFORMANCE:**  
THD+N: -92dB typ, -90dB max  
Dynamic Range: 108dB typ  
SNR: 108dB min, 110dB typ  
Channel Separation: 98dB typ, 94dB min
- **64X OVERSAMPLING**
- **CO-PHASE CONVERSION**
- **RUNS ON 256fs OR 384fs SYSTEM CLOCK**
- **VERSATILE INTERFACE CAPABILITY:**  
16-, 20-Bit Output  
MSB First or LSB First Format
- **OPTIONAL FUNCTIONS:**  
Offset Error Calibration  
Overflow Detection  
Power Down Mode (DF1760)
- **RUNS ON ±5V SUPPLIES (PCM1760) AND 5V SUPPLY (DF1760)**
- **COMPACT 28-PIN PACKAGES:**  
28-Pin DIP and SOIC

### DESCRIPTION

The PCM1760 and DF1760 combine for a low-cost, high-performance dual 20-bit, 48kHz sampling analog-to-digital conversion system which is specifically designed for dynamic applications.

The PCM1760/DF1760 pair form a 4-bit, 4th order, 64X oversampling analog-to-digital converter.

The PCM1760 is a delta-sigma modulator that uses a 4-bit quantizer within the modulation loop to achieve very high dynamic range.

The DF1760 is a high-performance decimating digital filter. The DF1760 accepts 4-bit 64fs data from the PCM1760 and decimates to 20-bit 1fs data.

The FIR filter of the DF1760 has pass-band ripple of less than  $\pm 0.001$ dB and greater than 100dB of the reject band attenuation.

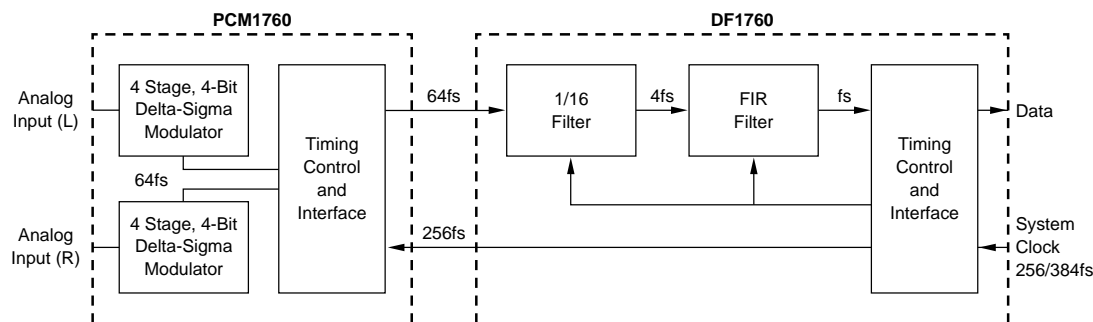

International Airport Industrial Park • Mailing Address: PO Box 11400 • Tucson, AZ 85734 • Street Address: 6730 S. Tucson Blvd. • Tucson, AZ 85706  
Tel: (520) 746-1111 • Twx: 910-952-1111 • Cable: BBRCORP • Telex: 066-6491 • FAX: (520) 889-1510 • Immediate Product Info: (800) 548-6132

# SPECIFICATIONS

## ELECTRICAL

At  $T_A = +25^\circ\text{C}$ ,  $\pm V_{CC}$ ,  $\pm V_{dd} = +5V$ ,  $+V_{DD} = +5V$ ,  $f_s = 48\text{kHz}$  and ext. components =  $\pm 2\%$  unless otherwise noted.

PARAMETER	CONDITIONS	PCM1760/DF1760			UNITS
		MIN	TYP	MAX	
RESOLUTION		20			Bits
<b>ANALOG INPUT</b>					
Input Range Input Impedance	$R_{IN1} = 2.2\text{k}\Omega$ $R_{IN1} = 2.2\text{k}\Omega$		$\pm 2.5$ $R_{IN1}$		Vp-p $\Omega$
<b>SAMPLING FREQUENCY</b>					
Cover Range of fs	Integrator Constants: Application <sup>(1)</sup>	30	48	50	kHz
<b>ACCURACY</b>					
Gain Error Gain Mismatch Bipolar Zero Error Gain Drift Bipolar Zero Drift	$V_{IN} = 0$ at 20s After Power-On $0^\circ\text{C}$ to $+70^\circ\text{C}$ $0^\circ\text{C}$ to $+70^\circ\text{C}$		$\pm 0.5$  $\pm 100$ $\pm 20$	$\pm 1.0$ $\pm 0.5$ $\pm 0.4$	dB dB % FSR <sup>(2)</sup> ppmfs/ $^\circ\text{C}$ ppmfs/ $^\circ\text{C}$
<b>DYNAMIC CHARACTERISTICS<sup>(4)</sup></b>					
THD+N/(0dBFS) P, U P-L, U-L	$f_{IN} = 1\text{kHz}$		-92 -90	-90 -88	dB dB
THD+N/(-20dBFS) P, U P-L, U-L	$f_{IN} = 1\text{kHz}$		-76 -76	-70 -70	dB dB
THD+N/(-60dBFS) P, U P-L, U-L	$f_{IN} = 1\text{kHz}$		-44 -44	-42 -42	dB dB
Dynamic Range P, U P-L, U-L	$f_{IN} = 1\text{kHz}$ , $V_{IN} = -60\text{dBFS}$ , A Filter	104 104	108 108		dB dB
SNR P, U P-L, U-L	$V_{IN} = 0$ , A Filter	108 106	110 110		dB dB
Frequency Response Channel Separation	$f_{IN} = 20\text{kHz}$ $f_{IN} = 1\text{kHz}$ , A Filter		$\pm 0.1$ 98		dB dB
<b>DIGITAL FILTER</b>					
Over Sample Rate Ripple in Band Stopband Attenuation -1 Stopband Attenuation -2	0 - 0.04535fs 0.5465fs - 63.4535fs 0.5465fs - 3.4535fs		64 -94 -100	$\pm 0.0001$	fs dB dB dB
<b>LOGIC INPUTS AND OUTPUTS</b>					
Logic Family Input Frequency (System Clock 1) Frequency (System Clock 2) Duty Cycle (System Clock 1) Duty Cycle (System Clock 2) Data Clock Input Logic Family Output Data Clock Output Data Coding Data Bit Length Data Format Output Data Delay	256fs 384fs 256fs 384fs  fs = 48kHz	40 45 32	TTL Level Compatible CMOS 12.288 18.432 50 50 48 64 CMOS 64 Two's Complement 20 Selectable 1.5		MHz MHz % % fs fs Bits ms
<b>POWER SUPPLY REQUIREMENTS</b>					
Supply Voltage $\pm V_{CC}$ $\pm V_{dd}$ $+V_{DD}$ Supply Current $+I_{CC}$ $-I_{CC}$ $+I_{dd}$ $-I_{DD}$ $+I_{DD} -1$ $+I_{DD} -2$ Power Consumption	PCM1760 PCM1760 DF1760 PCM1760 PCM1760 PCM1760 DF1760, Normal Mode DF1760, Power-Down Mode PCM1760 DF1760, Normal Mode DF1760, Power-Down Mode	$\pm 4.75$ $\pm 4.75$ 4.75	$\pm 5.0$ $\pm 5.0$ 5.0	$\pm 5.25$ $\pm 5.25$ 5.25	V V V mA mA mA mA mA mA mA mW mW mW
<b>TEMPERATURE RANGE</b>					
Operating Storage	PCM1760/DF1760 PCM1760/DF1760	0 -50	+25	+70 +125	$^\circ\text{C}$ $^\circ\text{C}$

NOTES: (1) Integrator Constants are determined by the external components shown in the block diagram. (2) FSR means Full Scale Range, digital output code is from 90000H to 70000H, FSR = 5.0V. (3) Use 20-bit DAC, 20kHz LPF, 400Hz HPF, average response. (4) Average response using a 20-bit reconstruction DAC with 20kHz low-pass filter and 400Hz high-pass filter.



## ABSOLUTE MAXIMUM RATINGS—PCM1760

Supply Voltage .....	±6V
Voltage Mismatch .....	0.1V
Analog Input .....	±V <sub>CC</sub>
Digital Input .....	+V <sub>DD</sub> +0.3V GND -0.3V
Power Dissipation/P .....	580mW
Power Dissipation/U .....	550mW
Lead Temperature/P (soldering, 10s) .....	260°C
Lead Temperature/U (soldering, 10s) .....	235°C
Operating Temperature .....	0°C to +70°C
Storage Temperature .....	-50°C to +125°C

## ABSOLUTE MAXIMUM RATINGS—DF1760

Supply Voltage .....	7.0V
Voltage Mismatch .....	0.1V
Digital Input .....	+V <sub>DD</sub> +0.5V V <sub>SS</sub> -0.5V
Input Current .....	±20mA
Power Dissipation/P .....	460mW
Power Dissipation/U .....	440mW
Lead Temperature/P (soldering, 10s) .....	260°C
Lead Temperature/U (soldering, 10s, reflow) .....	235°C
Operating Temperature .....	0°C to +70°C
Storage Temperature .....	-50°C to +125°C

## ORDERING INFORMATION

MODEL	PACKAGE	THD +N (fs)	SNR
PCM1760P	PDIP	-90dB	108dB
PCM1760U	SOIC	-90dB	108dB
PCM1760P-L	PDIP	-88dB	106dB
PCM1760U-L	SOIC	-88dB	106dB
DF1760P	PDIP	NA	NA
DF1760U	SOIC	NA	NA

## PACKAGE INFORMATION

MODEL	PACKAGE	PACKAGE DRAWING NUMBER <sup>(1)</sup>
PCM1760P	28-Pin PDIP	800
PCM1760U	28-Pin SOIC	804
PCM1760P-L	28-Pin PDIP	800
PCM1760U-L	28-Pin SOIC	804
DF1760P	28-Pin PDIP	801
DF1760U	28-Pin SOIC	805

NOTE: (1) For detailed drawing and dimension table, please see end of data sheet, or Appendix D of Burr-Brown IC Data Book.

## PIN ASSIGNMENTS PCM1760

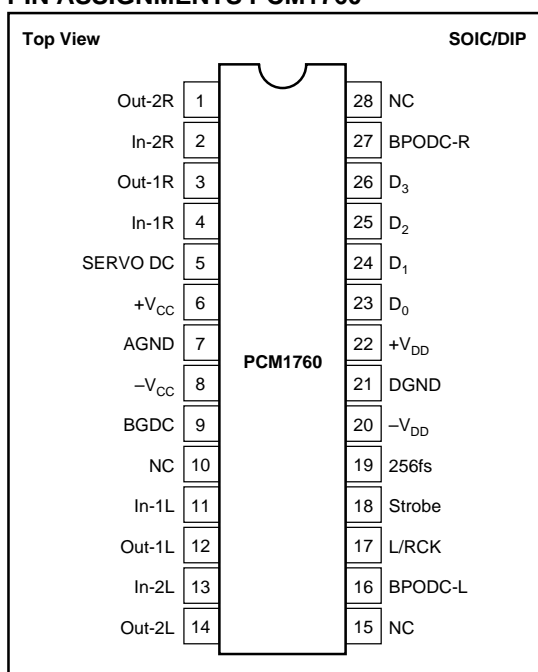

PIN	I/O <sup>(1)</sup>	NAME	DESCRIPTION
1	O	Out-2R	Right Channel Second Integrator Output
2	I	In-2R	Right Channel Second Integrator Input
3	O	Out-1R	Right Channel First Integrator Output
4	I	In-1R	Right Channel First Integrator Input
5	-	SERVO DC	Servo Amp Decoupling Capacitor
6	-	+V <sub>CC</sub>	+5V Analog Supply Voltage
7	-	AGND	Analog Common
8	-	-V <sub>CC</sub>	-5V Analog Supply Voltage
9	-	BGDC	Band Gap Reference Decoupling Capacitor
10	-	NC	No Connection
11	I	In-1L	Left Channel First Integrator Input
12	O	Out-1L	Left Channel First Integrator Output
13	I	In-2L	Left Channel Second Integrator Input
14	O	Out-2L	Left Channel Second Integrator Output
15	-	NC	No Connection
16	-	BPODC-L	Left Channel Bipolar Offset Decoupling Capacitor
17	O	L/RCK	LR Clock Output (64fs)
18	O	Strobe	Data Strobe Output (128fs)
19	I	256fs	256fs Clock Input
20	-	-V <sub>DD</sub>	-5V Digital Supply Voltage
21	-	DGND	Digital Common
22	-	+V <sub>DD</sub>	+5V Digital Supply Voltage
23	O	D <sub>0</sub>	D <sub>0</sub> Data Output (LSB)
24	O	D <sub>1</sub>	D <sub>1</sub> Data Output
25	O	D <sub>2</sub>	D <sub>2</sub> Data Output
26	O	D <sub>3</sub>	D <sub>3</sub> Data Output (MSB)
27	-	BPODC-R	Right Channel Bipolar Offset Decoupling Capacitor
28	-	NC	No Connection

NOTE: (1) O = Output terminal; I = Input terminal.

The information provided herein is believed to be reliable; however, BURR-BROWN assumes no responsibility for inaccuracies or omissions. BURR-BROWN assumes no responsibility for the use of this information, and all use of such information shall be entirely at the user's own risk. Prices and specifications are subject to change without notice. No patent rights or licenses to any of the circuits described herein are implied or granted to any third party. BURR-BROWN does not authorize or warrant any BURR-BROWN product for use in life support devices and/or systems.

## PIN ASSIGNMENTS DF1760

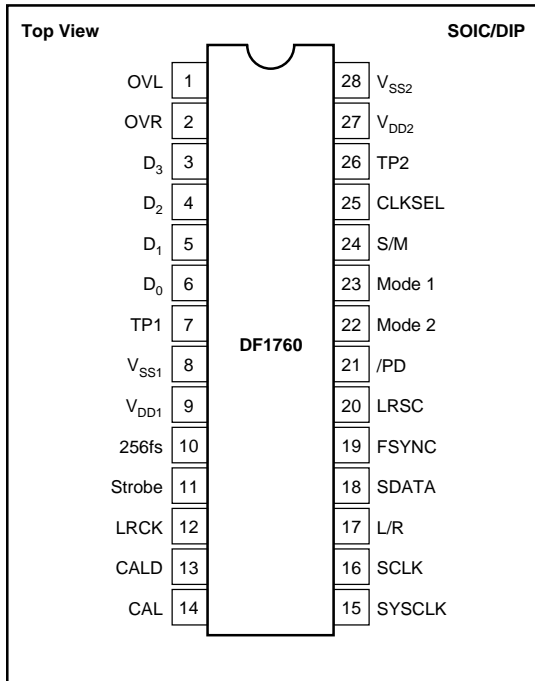

PIN	I/O <sup>(1)</sup>	NAME	DESCRIPTION
1	O	OVL	Left Channel Overflow Output (Active High)
2	O	OVR	Right Channel Overflow Output (Active High)
3	I	D <sub>3</sub>	D3 Data Input (MSB)
4	I	D <sub>2</sub>	D2 Data Input
5	I	D <sub>1</sub>	D1 Data Input
6	I	D <sub>0</sub>	D0 Data Input (LSB)
7	-	TP1	Test Pin (No Connection)
8	-	V <sub>SS1</sub>	Common Channel 1
9	-	V <sub>DD1</sub>	+5V Channel 1
10	O	256fs	256fs Clock Output
11	I	Strobe	Data Strobe Clock Input (128fs)
12	I	LRCK	LR Clock Input
13	I↑	CALD	Calibration Function Enable (Active Low)
14	O	CAL	Calibration Output (High During Calibration)
15	I	SYSCLK	System Clock Input (256fs or 384fs)
16	I↑/O	SCLK	Data Clock
17	I↑/O	L/R	LR Channel Phase Clock
18	O	SDATA	Serial Data Output (1fs)
19	I↑/O	FSYNC	Frame Clock (2fs)
20	I↑	LRSC	Phase Control of LR Channel Phase Clock
21	I↑	/PD	Power Down Mode Enable Input (Active Low)
22	I↑	Mode2	Output Format Selection Input 2
23	I↑	Mode1	Output Format Selection Input 1
24	I↑	S/M	Slave/Master Mode Selection Input (High Makes Slave Mode)
25	I↑	CLKSEL	System Clock Selection Input (High Makes 256fs)
26	-	TP2	Test Pin (No Connection)
27	-	V <sub>DD2</sub>	+5V Channel 2
28	-	V <sub>SS2</sub>	Common Channel 2

NOTE: (1) O = Output terminal; I = Input terminal.

## BLOCK DIAGRAM OF DF1760

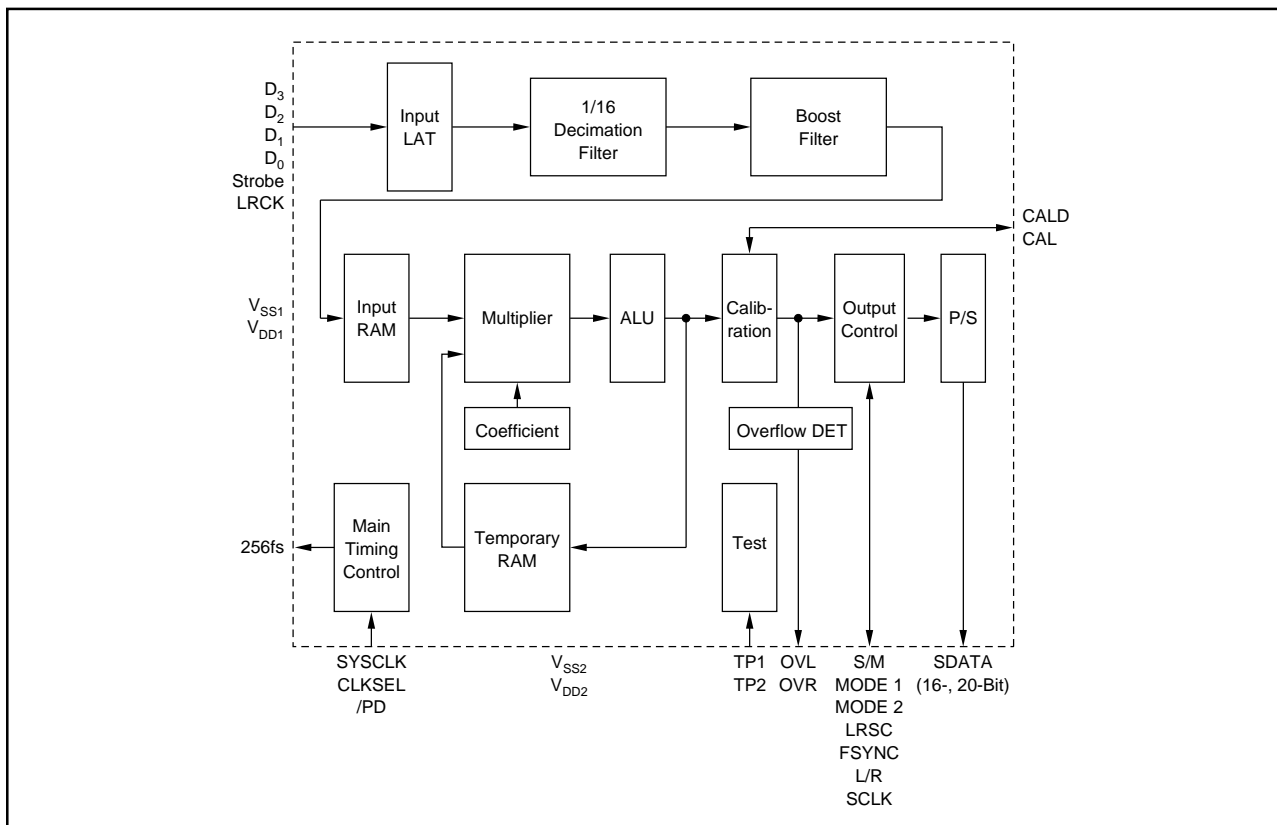

# BLOCK DIAGRAM OF PCM1760



# TYPICAL PERFORMANCE CURVES

OVERALL PASS-BAND CHARACTERISTICS OF THE DF1760

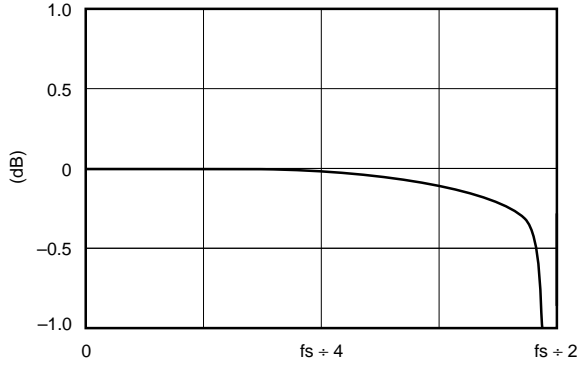

OVERALL CHARACTERISTICS OF THE DF1760

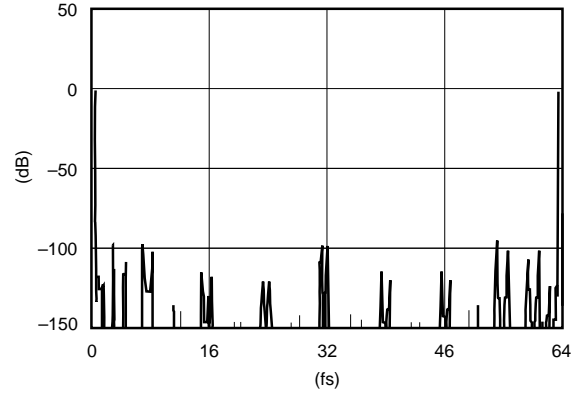

PASS-BAND CHARACTERISTICS OF THE FIR PORTION OF THE DF1760

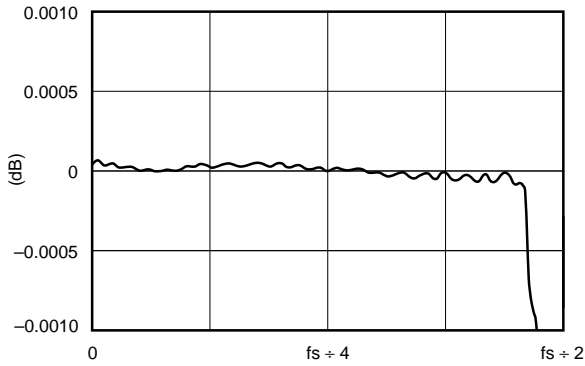

TOTAL PASS-BAND FREQUENCY RESPONSE, COMBINATION OF PCM1760 AND DF1760

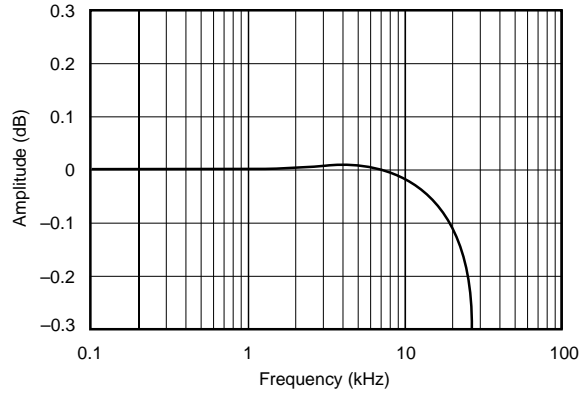

TYPICAL FFT ANALYSIS OF THE 1kHz fs INPUT SIGNAL

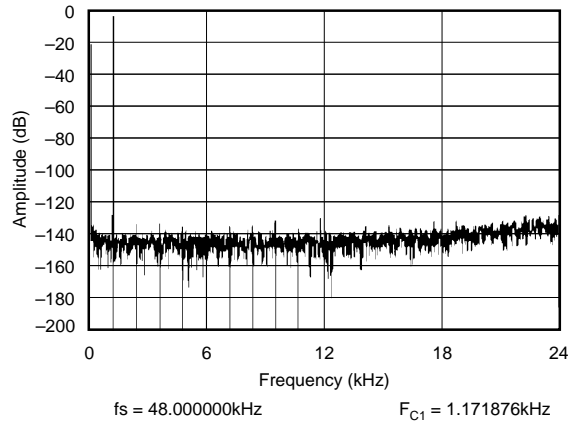

# BASIC CONNECTION DIAGRAM OF PCM1760 AND DF1760

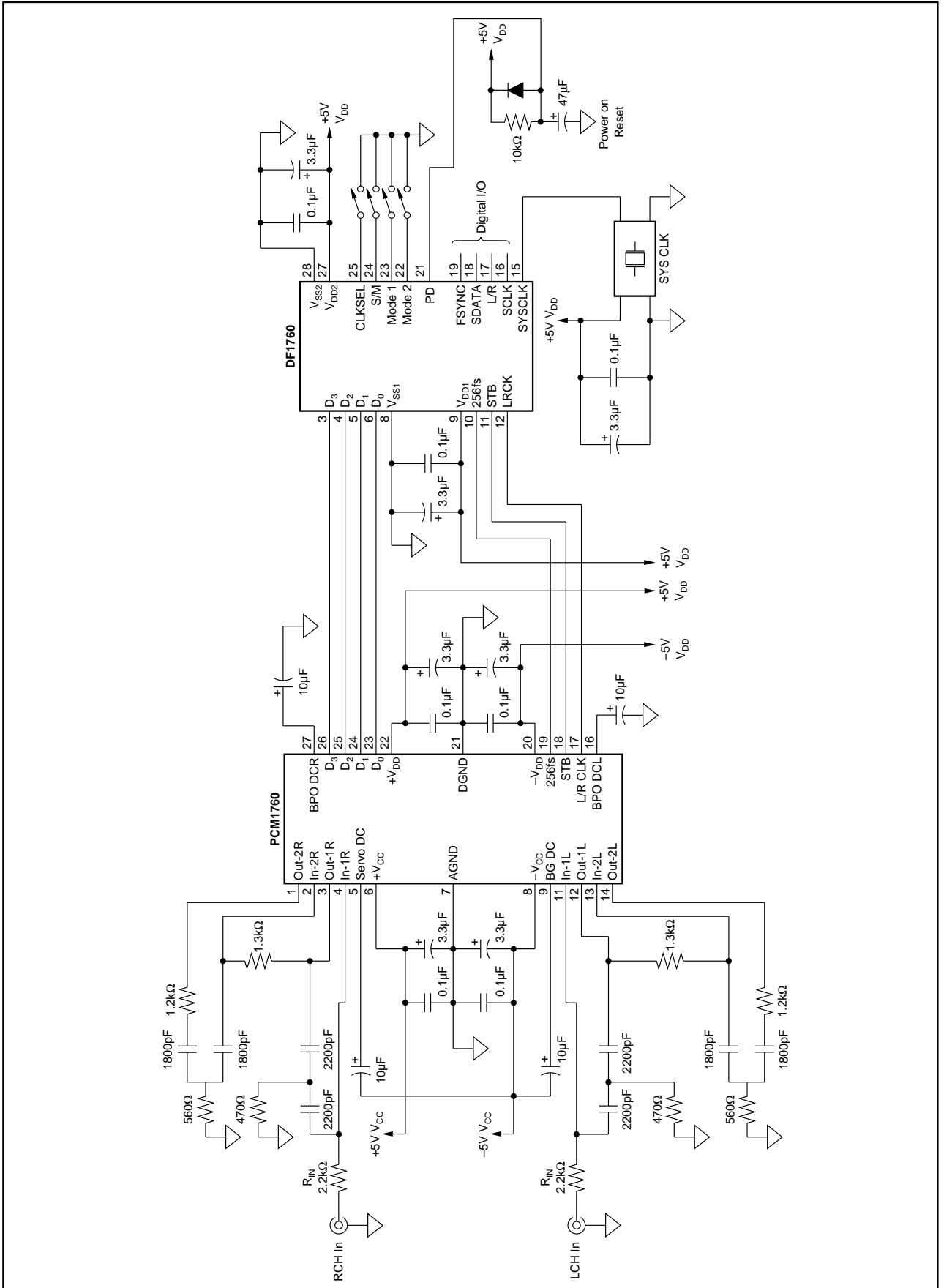

# FUNCTIONS OF THE DIGITAL FILTER

## SYSTEM CLOCK

The DF1760 can accept a system clock of either 256fs or 384fs. If a 384fs system clock is used, the DF1760 divides by 2/3 to create the 256fs system clock required for the PCM1760. The system clock is applied to pin 15 (SYSCLK input). The actual clock selection is done by setting pin 25 (CLKSEL input) “high” for 256fs clock and “LOW” for 384fs clock.

The detailed timing requirements for the system clock are shown in Figure 3c.

CLKSEL	SYSCLK
H	256fs
L	384fs

## MASTER/SLAVE MODE

The DF1760 can be used in both the master mode and slave mode. In the master mode, the DF1760 outputs L/R (left/right channel phase clock), SCLK (data clock) and FSYNC (frame clock 2fs) signals. In the slave mode, the DF1760 accepts L/R, SCLK and FSYNC signals. The mode selection is done by taking pin 24 (S/M INPUT) “HIGH” for slave mode and “LOW” for master mode.

S/M	MODE
H	Slave
L	Master

## OUTPUT DATA FORMAT

The serial output data has four possible formats. The selection of the formats can be done by the Mode 1 and Mode 2 inputs.

MODE 1	MODE 2	FORMATS
H	H	MSB First, 16 Bits, Falling Edge
L	H	MSB First, 20 Bits, Falling Edge
H	L	MSB First, 20 Bits, Rising Edge
L	L	LSB First, 20 Bits, Falling Edge

## LR CHANNEL PHASE CLOCK

The status of the LR channel phase clock can be set by the LRSC input.

LRSC	L/R CLOCK AND CHANNEL
H	H = LCH, L = RCH
L	L = LCH, H = RCH

## OVERFLOW DETECTION

When a near-to-clipping input condition is detected, OVL output (Pin 1), or OVR output (Pin 2), becomes “HIGH” for a duration of 4096/fs (about 85ms) depending upon on the channel detected.

The OVL and OVR output return to “LOW” after 4096/fs duration automatically.

## OFFSET CALIBRATION MODE

The offset error is calibrated by storing the digital data when the input is zero in registers and subtracting it from the future data with actual signal input.

CALD	CALIBRATION
H	Disable
L	Enable

To enable the calibration mode, set the CALD input (Pin 13) “LOW”. The calibration mode is disabled by setting the CALD input (Pin 13) “HIGH”. The calibration cycle is initiated by setting the /PD input (Pin 21) “LOW” for more than 2 system clock periods and then setting it “HIGH”. During the calibration cycle, the CAL output (Pin 14) becomes “HIGH”, all the serial data is forced to “LOW”, and the L/R (Pin 17), SCLK (Pin 16) and FSYNC (Pin 19) pins become input terminals after the completion of the calibration cycle. The CAL output is “LOW”.

## POWER DOWN MODE/RESET

The /PD input (Pin 21) has two functions. First, it should be set at “HIGH” after application or restoration of power ( $V_{SS}$  and/or  $V_{DD}$ ) to accomplish the power-on/mode reset function. The detail timing requirements for this function are shown in Figure 3f. Second, the DF1760 is placed in the power down mode by setting the /PD input (Pin 21) “LOW”. Set the /PD input (Pin 21) “HIGH” for normal operation mode.

/PD	OPERATION
H	Normal
L	Power Down

The power dissipation of the DF1760 in the power down mode is about 1/10 of the normal operation mode. During the power down mode, the L/R, SCLK, and FSYNC pins become input pins and all the serial data is forced “LOW”. The 256fs output is enabled even in the power down mode.

The detailed timing of the power down mode operation and the offset calibration is shown in Figure 3b.

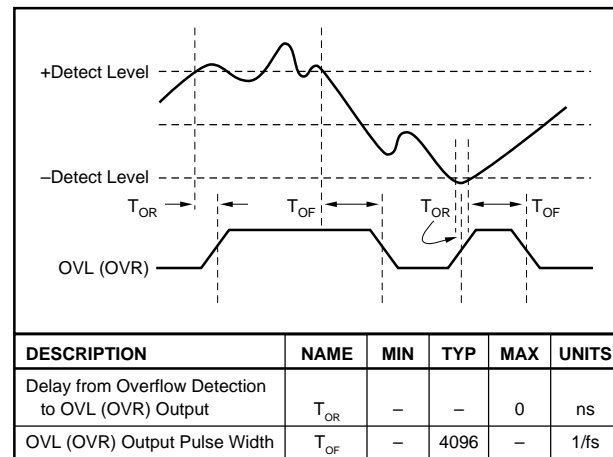

FIGURE 3a. DF1760 Overflow Detection.

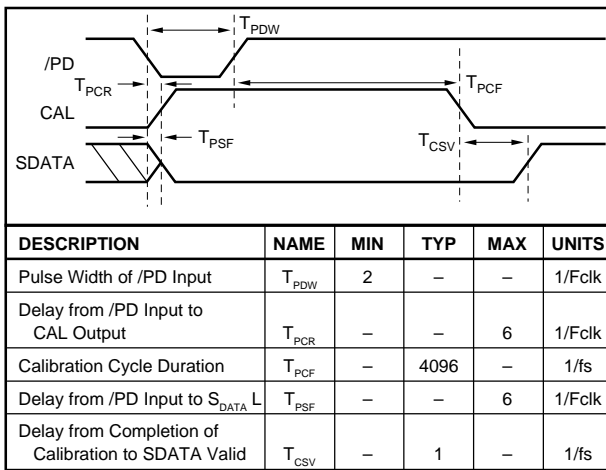

FIGURE 3b. DF1760 Power Down and Offset Calibration.

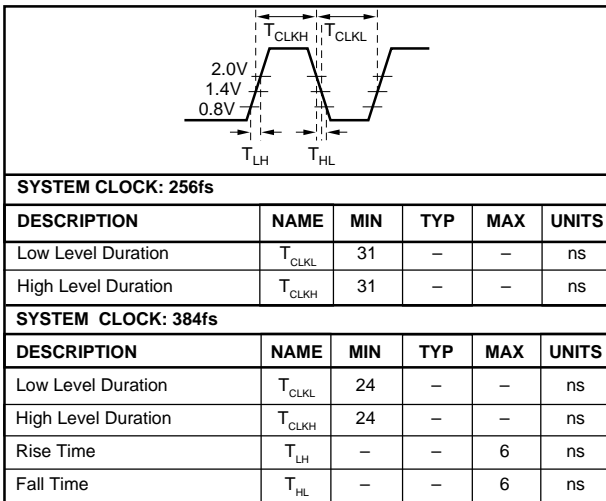

FIGURE 3c. System Clock Timing Requirements of DF1760.

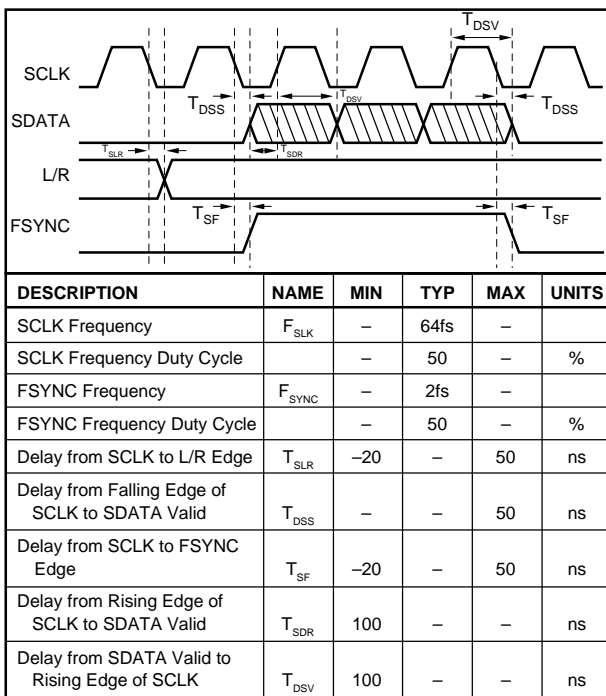

FIGURE 3d. Output Timing of Master Mode, DF1760.

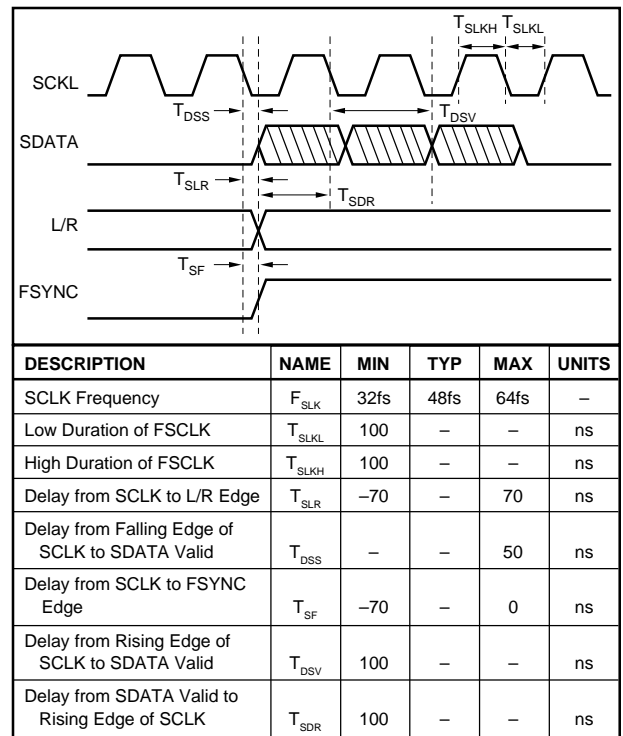

FIGURE 3e. Timing of Slave Mode, DF1760.

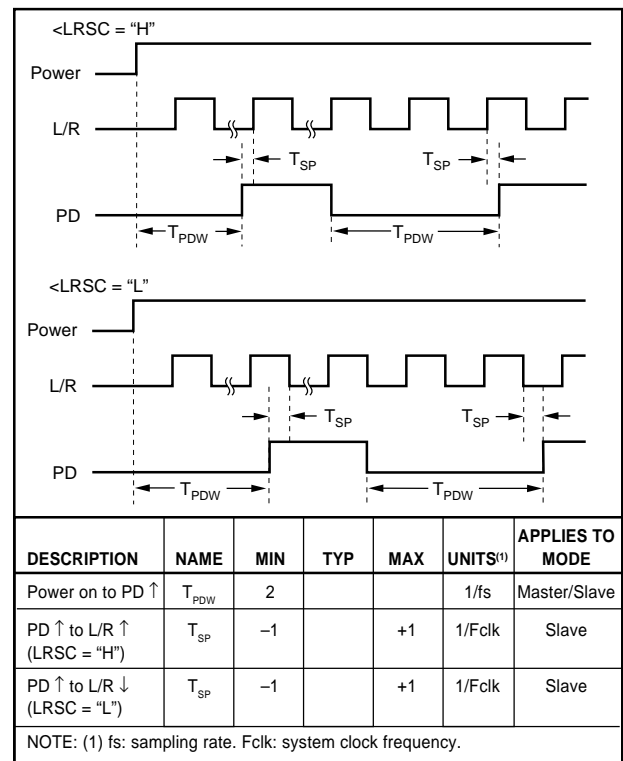

FIGURE 3f. Power On and Mode Reset Timing.

# THEORY OF OPERATION

## MULTI-BIT ENHANCED NOISE SHAPING

A block diagram of a typical 1-bit delta-sigma modulator is shown in Figure 4.

In Figure 4, the quantizer consists of a single bit which has two possible states, either “0” or “1”. The input signal is sampled at a much higher sample rate than the nyquist sampling frequency. The quantizer output data stream is digitally filtered for higher resolution nyquist data. The theoretical SNR is determined by the number of the order of the integrator and the oversampling rate.

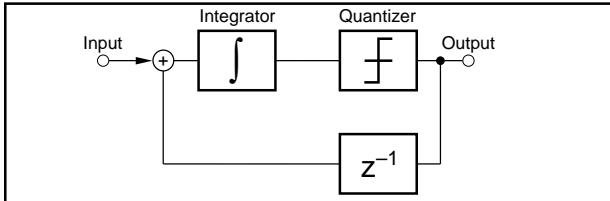

FIGURE 4. Single Stage 1-Bit Delta-Sigma.

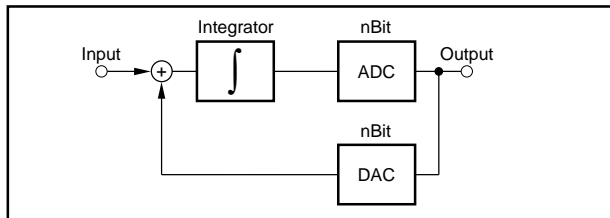

FIGURE 5. Single Stage Multi-bit Delta-Sigma.

There is a practical limit to increasing the numbers of order of the integrator due to an inherent oscillation in the modulator. There is also a limit to increasing the sample rate due to the increase in jitter sensitivity associated with high clock frequencies.

The PCM1760 utilizes a four-bit quantizer instead of the conventional one-bit method. The quantizing noise of a four-bit quantizer is 1/16 of the one-bit version. Using the four-bit quantizer allows for a lesser order number of the integrator and a lower oversampling rate to achieve similar performance to that of a more complex one-bit system.

A block diagram of the PCM1760 modulator is shown in Figure 6. The PCM1760 is a fourth-order integrator that samples at 64x oversampling, and samples left and right channel input signal simultaneously.

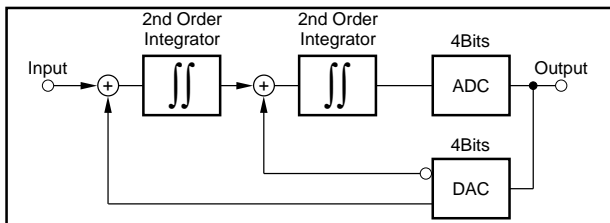
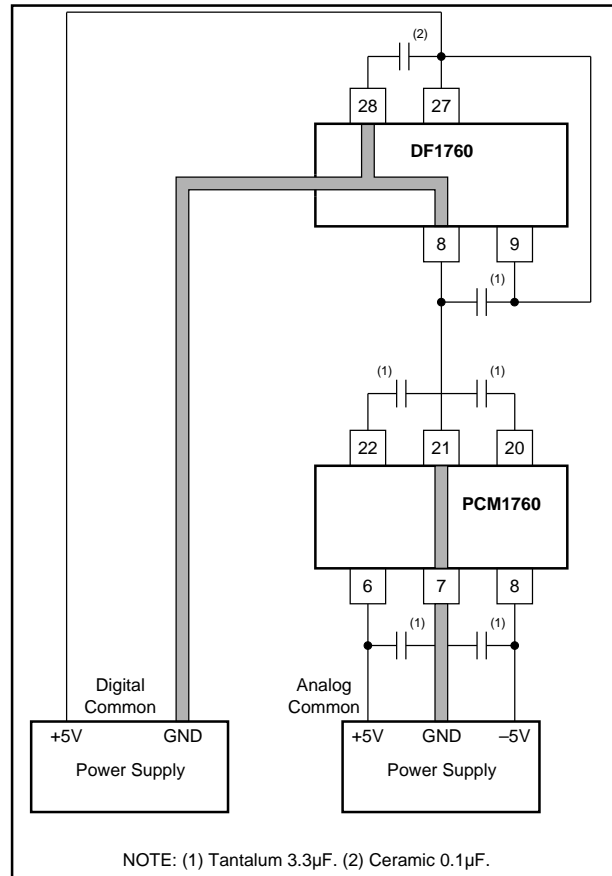

FIGURE 6. Multi-bit Enhanced Noise Shaping.

The DF1760 accepts the four-bit 64fs noise shaped data stream from the PCM1760 and decimates to 1/16 with an initial filter, and then decimates to 1fs 20-bit data using a 4x oversampling filter.

The PCM1760 and DF1760 combination achieves a dynamic range of 108dB and SNR of 110dB even with a single-ended input.



NOTE: (1) Tantalum 3.3µF. (2) Ceramic 0.1µF.

FIGURE 7. Recommended Power Supply Connection and Decoupling.

## LAYOUT PRECAUTIONS

Analog common and digital common of the PCM1760 are not connected internally. These should be connected together with the common of the DF1760 as close to the unit as possible, preferably to a large ground plane under the PCM1760.

The use of a separate +5V supply is recommended for the PCM1760 and DF1760, and to connect the common at one point as described above. Low impedance analog and digital commons returns are essential for better performance.

The power supplies should be bypassed with tantalum capacitors as close as possible to the units. See Figure 7 for recommended common connections and power supplies bypassing.

## OUTPUT TONE ELIMINATION

When the sampling frequency ( $f_s$ ) is between 40kHz and 50 kHz and the L/R relative offset voltage ( $\Delta V_s$ ) is less than or equal to 0.05% of full scale range, the PCM1760 may output a tone similar to an idle tone. This tone is very low and its frequency depends on the input L/R relative offset voltage,  $\Delta V_s$ . This tone never occurs when the sampling frequency ( $f_s$ ) is 32kHz.

To avoid this tone, the offset voltage should be summed using an amplifier, buffer, active low pass filter, etc., to cause the input L/R relative offset voltage ( $\Delta V_s$ ) to be greater than 0.05% of full scale range.

It is recommended that:

(A) Sum offset at both L/R channels

Lch:  $V_{IL} = -20\text{mV} \pm 10\%$

Rch:  $V_{IR} = +10\text{mV} \pm 10\%$

(B) Sum offset at L channel

Lch:  $V_{IL} = -30\text{mV} \pm 10\%$

Rch:  $V_{IR} = \pm 1\text{mV}$  (by a precircuit)

When FSR = 5V ( $\pm 2.5\text{V}$ ).

Figure 8 shows an application circuit for summing the offset at both L/R channels.

Alternately, Figure 9 shows an application circuit for use when  $f_s = 48\text{kHz}$  which changes the external integrator circuit of the PCM1760.

## MODULATOR COMPONENTS AND SAMPLING FREQUENCY

The PCM1760/DF1760 are capable to 30kHz to 50kHz  $f_s$  sampling frequency by condition with external components value which are shown in Basic Connection Diagram.

The characteristics of the modulator's integrator can be set by external components. The values in the block diagram on page five are recommended for optimized performance. Low leakage, low voltage coefficient capacitors are recommended for integration capacitors.

The tolerance of external components should be better than  $\pm 2\%$ .

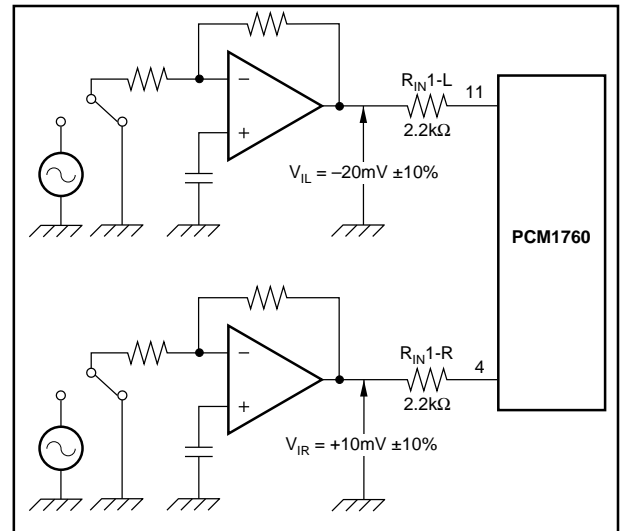

FIGURE 8. Application Example to Eliminate the Tone (offset voltage implementation for both channels).

## OFFSET ERROR CALIBRATION

The offset voltage of the PCM1760 and the input stage of the system can be compensated by using the calibration mode of the DF1760. Offset calibration is shown in Figure 10. An optional analog switch is driven by a CAL output of the DF1760. The PD input of the DF1760 is used to initiate the calibration cycle.

## ANALOG INPUT AND DIGITAL OUTPUT

Ideal output digital code range for 20-bit resolution is from 8000H (-Full Scale) to 7FFFH (+Full Scale).

The DF1760, combined with 70000H ( $\pm\text{FSR}$ ) of the PCM1760, produces a digital output code range at  $\pm\text{FSR}$  input of 90000H (-FSR).

The relationship between analog input and digital output is shown in Table I.

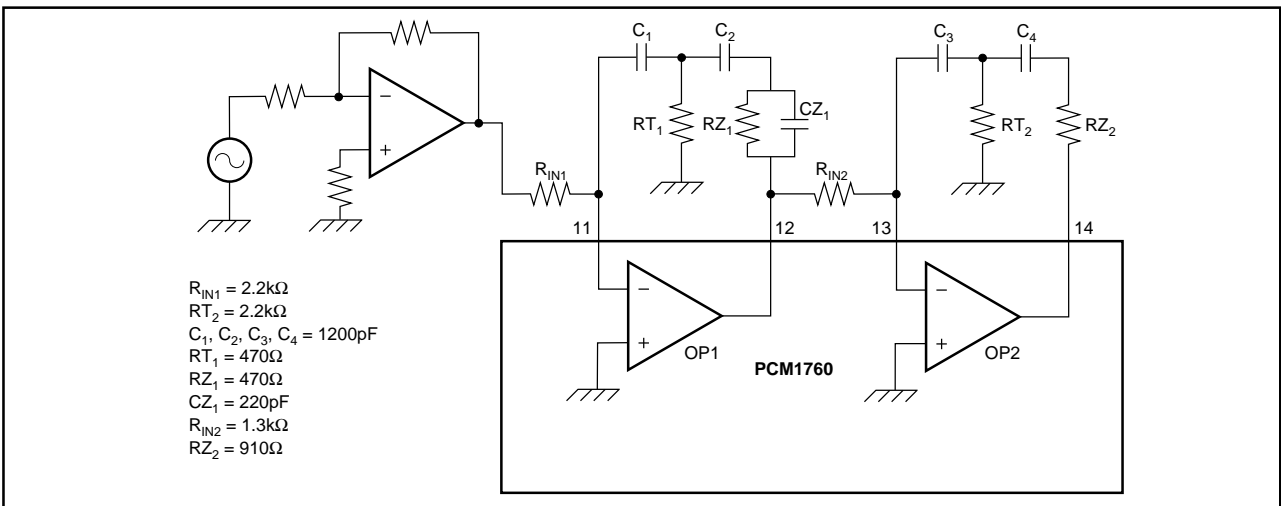

FIGURE 9. Application Example to Eliminate the Tone (alternative modulator's integrator circuit. Only for  $f_s = 48\text{kHz}$ ).

ANALOG INPUT	CONDITION	DIGITAL OUTPUT
+2.55V	+Max Input	72000H
+2.50V to +2.55V	Overflow	70000H to 72000H <sup>(2)</sup>
+2.50V	+FSR	70000H
0V	BPZ (Ideal)	00000H <sup>(1)</sup>
-2.50V	-FSR	90000H
-2.83V to -2.85V	Overflow	82FFFH to 82000H <sup>(2)</sup>
-2.85V	-Max Input	82000H

NOTES: (1) Incase of BPZ Error = 0. (2) Overflow detection level is over 70000H or under 82FFFH of digital output code.

TABLE I. Output Codes.

### POWER SUPPLY SEQUENCING

The PCM1760 requires  $\pm V_{CC}$  and  $\pm V_{DD}$  power supplies. To avoid any possibility of latch-up, the  $\pm V_{CC}$  and  $\pm V_{DD}$  power should all be applied simultaneously or the  $+V_{CC}$  and  $+V_{DD}$  applied first followed by  $-V_{CC}$  and  $-V_{DD}$ .

### POWER-ON RESET AND MODE RESET

The timing requirements for POWER-ON RESET and MODE RESET are shown in Figure 3f. The DF1760 requires POWER-ON RESET when power is applied or restored. MODE RESET is required when any of the following has been changed: system clock, master/slave mode, output data format, L/R clock, calibration after POWER-ON in slave mode.

This reset should be done by holding the /PD input (pin 21) low for more than  $2/f_s$ . Suggested reset circuits are given in Figures 11, 12 and 13.

### CLOCK INPUT

After power is applied to the DF1760, the system clock should be provided continuously. The DF1760 employs a dynamic logic architecture.

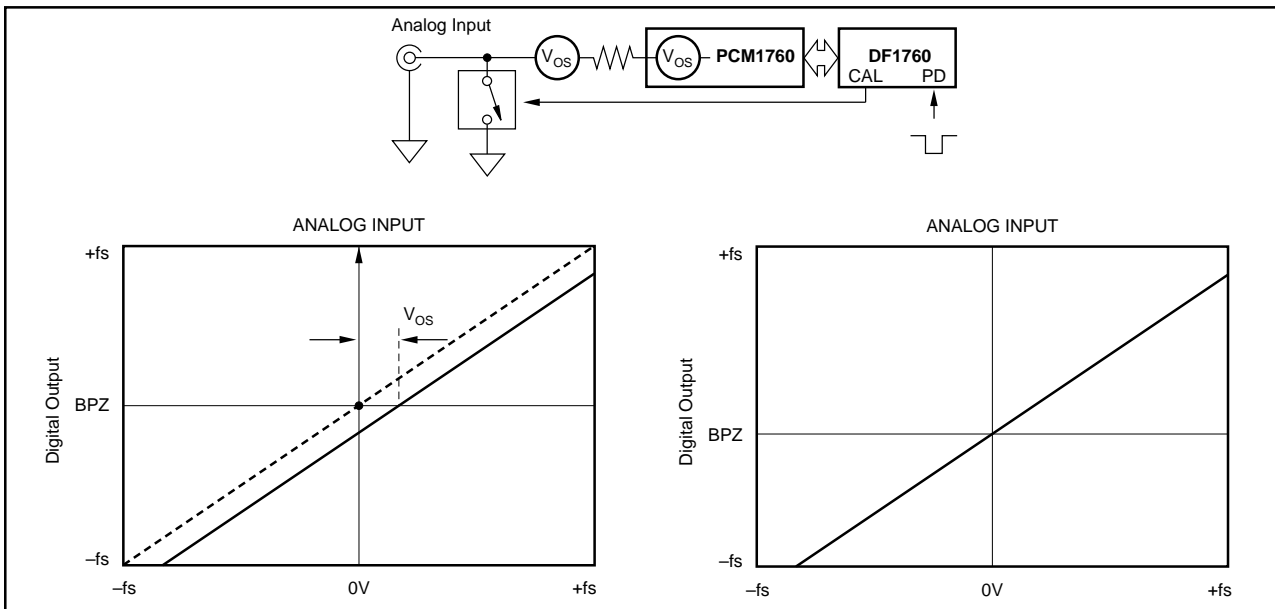

FIGURE 10. Illustration of Offset Calibration.

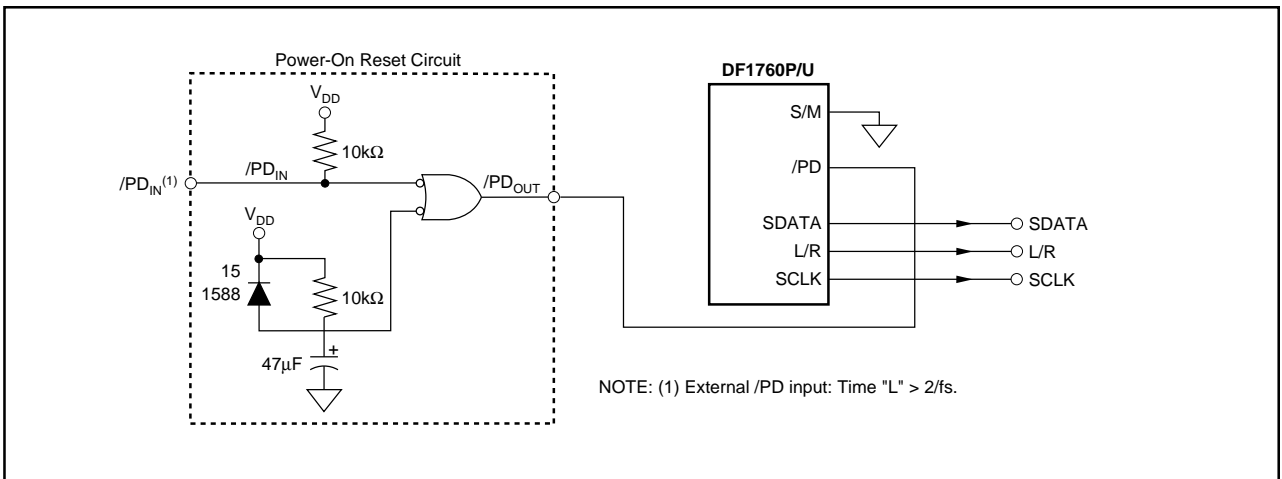

FIGURE 11. Master Mode Reset Circuit.

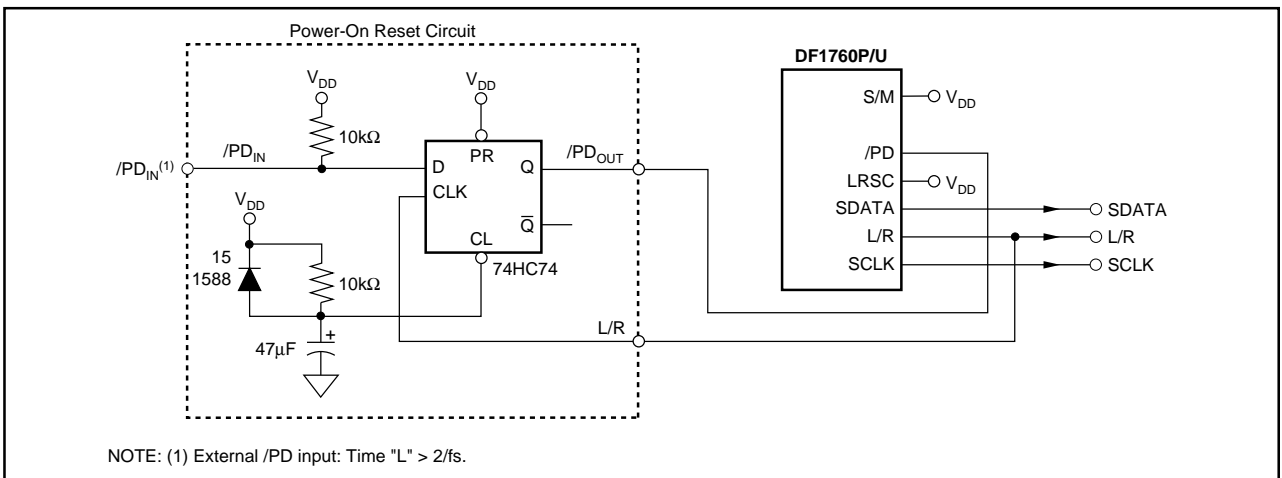

FIGURE 12. Slave Mode Reset Circuit, (LRSC = H).

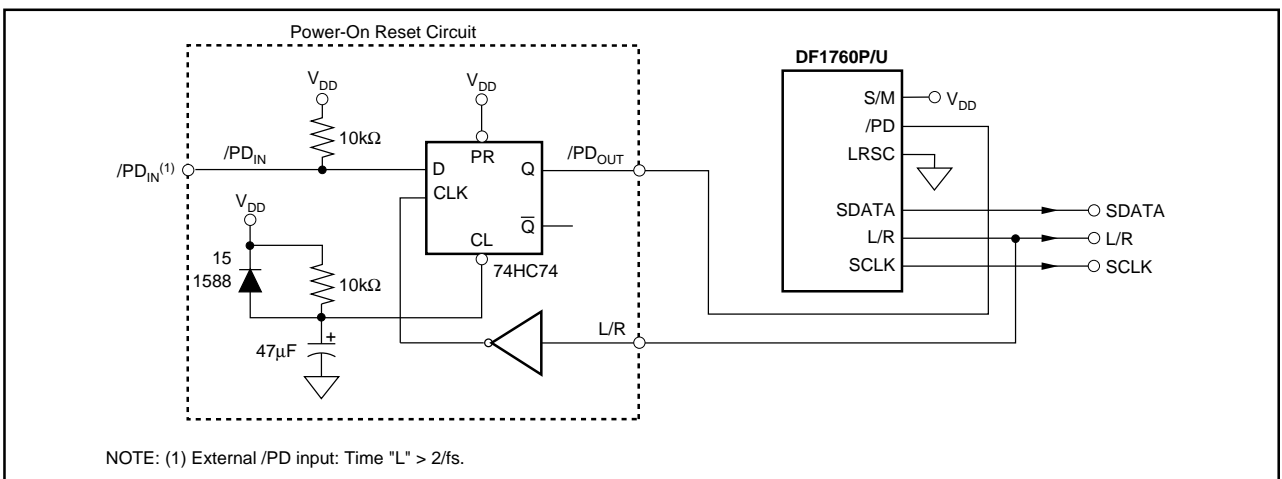

FIGURE 13. Slave Mode Reset Circuit, (LRSC = L).

# TIMING CHARACTERISTICS

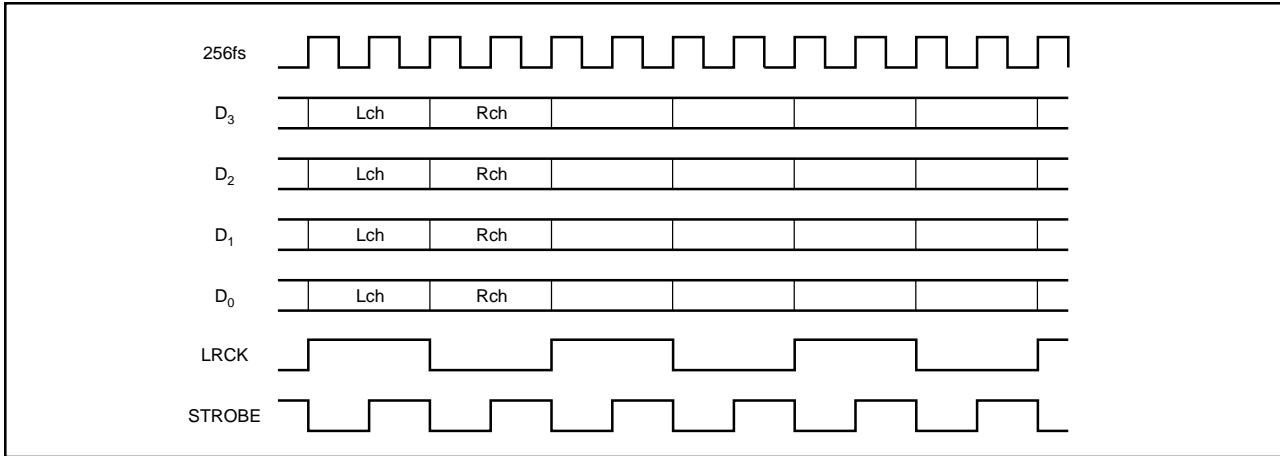

FIGURE 14. Input and Output Format of the DF1760 and PCM1760.

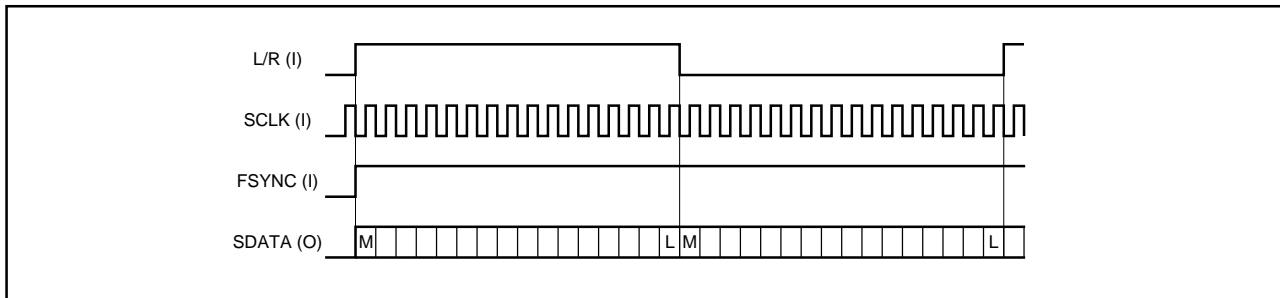

FIGURE 15a. Slave Mode and SCLK = 32fs. (Output format of the DF1760).

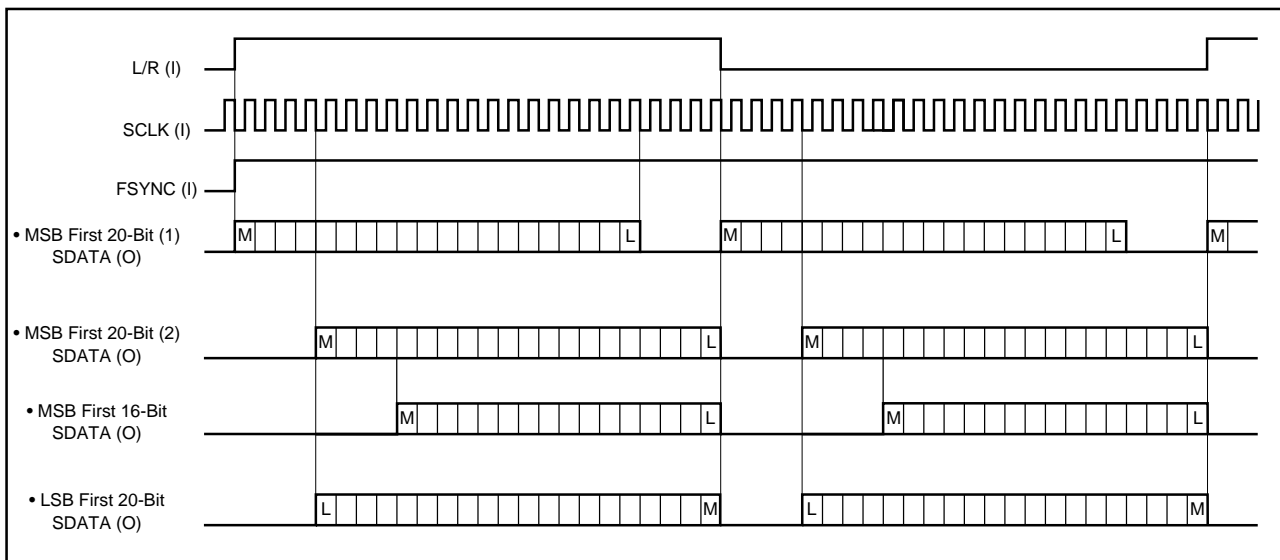

FIGURE 15b. Slave Mode and SCLK = 48fs.

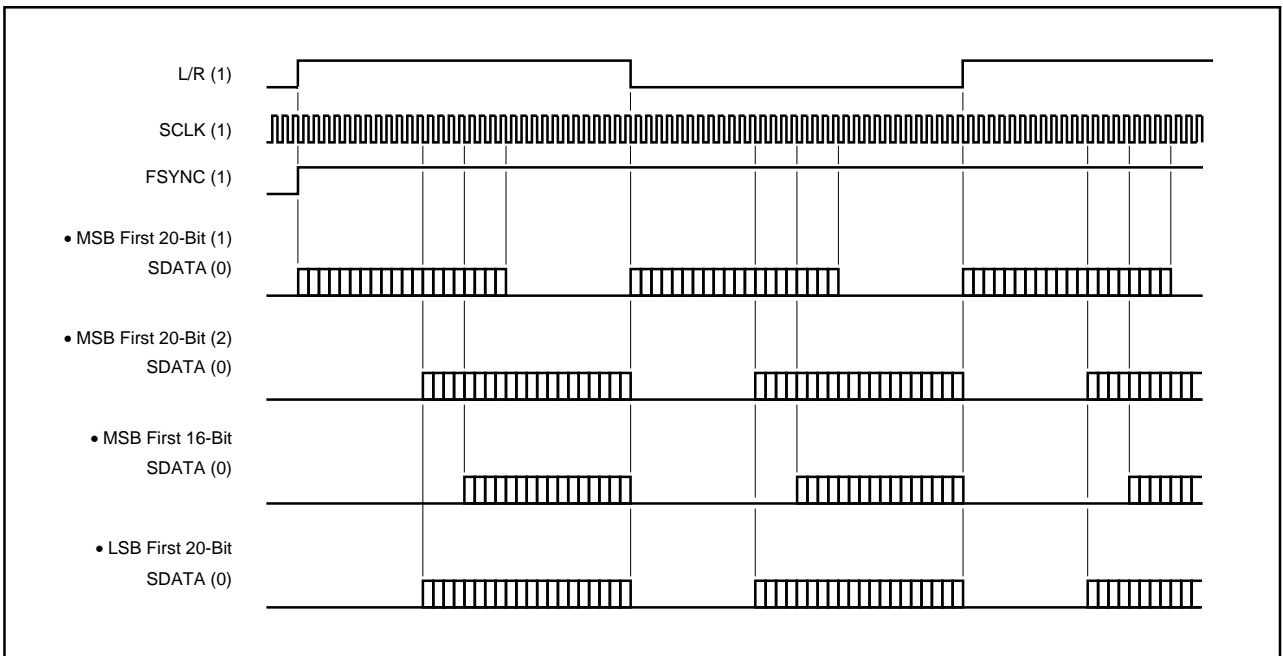

FIGURE 15c. Slave Mode and SCLK = 64fs.

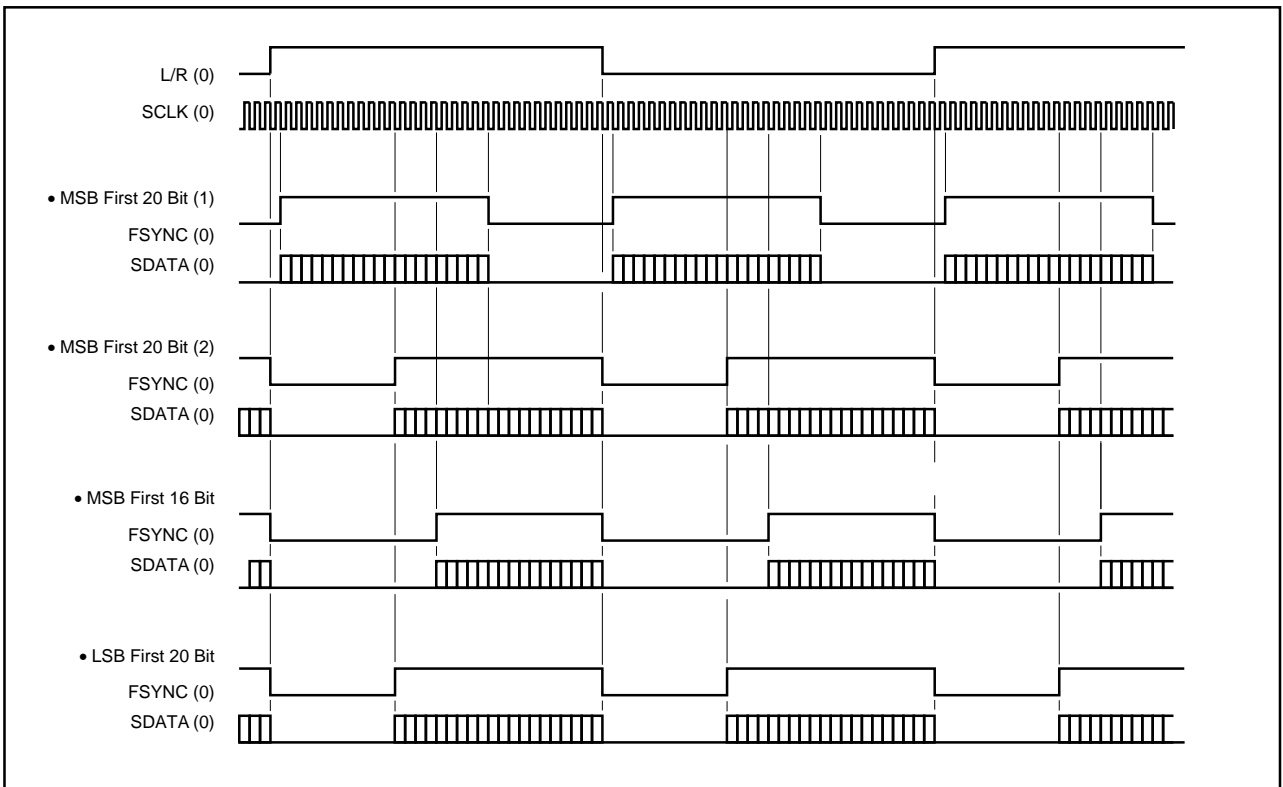

FIGURE 15d. Master Mode.

---

**PACKAGING INFORMATION**

ORDERABLE DEVICE	STATUS(1)	PACKAGE TYPE	PACKAGE DRAWING	PINS	PACKAGE QTY
DF1760P	ACTIVE	PDIP	N	28	12
DF1760U	ACTIVE	SOP	NS	20	26
DF1760U/1K	ACTIVE	SOP	NS	20	1000
PCM1760P-L	ACTIVE	PDIP	NTD	28	12
PCM1760U	ACTIVE	SOIC	DW	28	
PCM1760U-L	ACTIVE	SOIC	DW	28	28
PCM1760U-L/1K	ACTIVE	SOIC	DW	28	

(1) The marketing status values are defined as follows:

**ACTIVE:** Product device recommended for new designs.

**LIFEBUY:** TI has announced that the device will be discontinued, and a lifetime-buy period is in effect.

**NRND:** Not recommended for new designs. Device is in production to support existing customers, but TI does not recommend using this part in a new design.

**PREVIEW:** Device has been announced but is not in production. Samples may or may not be available.

**OBSOLETE:** TI has discontinued the production of the device.

---

## IMPORTANT NOTICE

Texas Instruments Incorporated and its subsidiaries (TI) reserve the right to make corrections, modifications, enhancements, improvements, and other changes to its products and services at any time and to discontinue any product or service without notice. Customers should obtain the latest relevant information before placing orders and should verify that such information is current and complete. All products are sold subject to TI's terms and conditions of sale supplied at the time of order acknowledgment.

TI warrants performance of its hardware products to the specifications applicable at the time of sale in accordance with TI's standard warranty. Testing and other quality control techniques are used to the extent TI deems necessary to support this warranty. Except where mandated by government requirements, testing of all parameters of each product is not necessarily performed.

TI assumes no liability for applications assistance or customer product design. Customers are responsible for their products and applications using TI components. To minimize the risks associated with customer products and applications, customers should provide adequate design and operating safeguards.

TI does not warrant or represent that any license, either express or implied, is granted under any TI patent right, copyright, mask work right, or other TI intellectual property right relating to any combination, machine, or process in which TI products or services are used. Information published by TI regarding third-party products or services does not constitute a license from TI to use such products or services or a warranty or endorsement thereof. Use of such information may require a license from a third party under the patents or other intellectual property of the third party, or a license from TI under the patents or other intellectual property of TI.

Reproduction of information in TI data books or data sheets is permissible only if reproduction is without alteration and is accompanied by all associated warranties, conditions, limitations, and notices. Reproduction of this information with alteration is an unfair and deceptive business practice. TI is not responsible or liable for such altered documentation.

Resale of TI products or services with statements different from or beyond the parameters stated by TI for that product or service voids all express and any implied warranties for the associated TI product or service and is an unfair and deceptive business practice. TI is not responsible or liable for any such statements.

Following are URLs where you can obtain information on other Texas Instruments products and application solutions:

<b>Products</b>		<b>Applications</b>	
Amplifiers	<a href="http://amplifier.ti.com">amplifier.ti.com</a>	Audio	<a href="http://www.ti.com/audio">www.ti.com/audio</a>
Data Converters	<a href="http://dataconverter.ti.com">dataconverter.ti.com</a>	Automotive	<a href="http://www.ti.com/automotive">www.ti.com/automotive</a>
DSP	<a href="http://dsp.ti.com">dsp.ti.com</a>	Broadband	<a href="http://www.ti.com/broadband">www.ti.com/broadband</a>
Interface	<a href="http://interface.ti.com">interface.ti.com</a>	Digital Control	<a href="http://www.ti.com/digitalcontrol">www.ti.com/digitalcontrol</a>
Logic	<a href="http://logic.ti.com">logic.ti.com</a>	Military	<a href="http://www.ti.com/military">www.ti.com/military</a>
Power Mgmt	<a href="http://power.ti.com">power.ti.com</a>	Optical Networking	<a href="http://www.ti.com/opticalnetwork">www.ti.com/opticalnetwork</a>
Microcontrollers	<a href="http://microcontroller.ti.com">microcontroller.ti.com</a>	Security	<a href="http://www.ti.com/security">www.ti.com/security</a>
		Telephony	<a href="http://www.ti.com/telephony">www.ti.com/telephony</a>
		Video & Imaging	<a href="http://www.ti.com/video">www.ti.com/video</a>
		Wireless	<a href="http://www.ti.com/wireless">www.ti.com/wireless</a>

Mailing Address: Texas Instruments  
Post Office Box 655303 Dallas, Texas 75265

## Looking for pricing, stock, or lifecycle information?

Click below to explore more details on WIN SOURCE:

 [View DF1760U on WIN SOURCE](#)

 [Texas Instruments](#) Information

## Optimize Your Supply Chain with WIN SOURCE Solutions

-  Global Sourcing Solution
-  Obsolete Management
-  Cost Control Management
-  Shortage Management
-  Alternative Solution
-  Excess Inventory Management