



**THE DATASHEET OF
CJ1W-IC101**



Power and Expansion Selection

This section provides tools to calculate the CJ1 system current consumption total needed to select the power supply. When the number of modules or power requirements exceeds the capability of the power supplies available, I/O expansion racks solve the problem. If the number of modules per rack exceeds 10 or the current consumption is greater than the capacity of the power supply units, use the CPU and expansion rack configuration.

What is the basic configuration?

A CJ1 system consists of a power supply, a CPU, and up to 10 basic I/O, special I/O and CPU bus units, and an end cover. See page B-109.

What goes on expansion I/O racks?

The expansion I/O rack contains a power supply, an I/O interface module and the remaining I/O modules. Each expansion rack requires a power supply, the I/O interface module and up to 10 more modules.

Where are ratings to calculate overall current consumption?

All the current consumption ratings for the CPU, basic I/O, special I/O and CPU bus units are collected in the tables on pages B-110 to B-111.

Which power supply is right?

Compare the current consumption total of basic I/O, special I/O, and CPU bus units to determine which power supply to use.

Input Voltage	100 to 240 VAC		24 VDC
Output rating	5 A, 5 VDC with 2 A RUN output	2.8 A, 5 VDC	5 A, 5 VDC
Output capacity	25 W max.	14 W max.	25 W max.
Power supply model	CJ1W-PA205R	CJ1W-PA202	CJ1W-PD025
See page	B-110	B-110	B-110

Note: If more than 10 modules are required or the current consumption exceeds the output capacity of the power supplies, go to page B-109 for configuration of I/O expansion racks. The same power supply units can be used for both CPU and I/O expansion racks.

How many expansion I/O racks can be used?

Depending on the CPU chosen, the system can be expanded with up to three additional racks of basic I/O, special I/O and CPU bus units.

Maximum I/O modules per CPU	40	30	20	10	10
Maximum I/O expansion racks per CPU	3	2	1	0	0
CPU models	CJ1G-CPU44H	CJ1G-CPU42H	CJ1M-CPU13	CJ1M-CPU12	CJ1M-CPU11
	CJ1G-CPU45H	CJ1G-CPU43H	CJ1M-CPU23	CJ1M-CPU22	CJ1M-CPU21
	CJ1H-CPU65H				
	CJ1H-CPU66H				

Note: Order one CJ1W-IC101 I/O control module for the CPU rack and one CJ1W-II101 I/O interface module for each I/O expansion rack. Connect the modules with a cable of the appropriate length. Second and third I/O expansion racks connect between I/O interface modules. See page B-117 for details.

■ Basic Configuration

A CJ1 Series basic configuration consists of a CPU, Power Supply Unit, Basic I/O Modules, Special I/O Modules, CPU Bus Modules, and an End Cover. Add up the current consumption of all the modules and the CPU according to the formula on the following page and then select the Power Supply Unit right for the application.

Basic Configuration

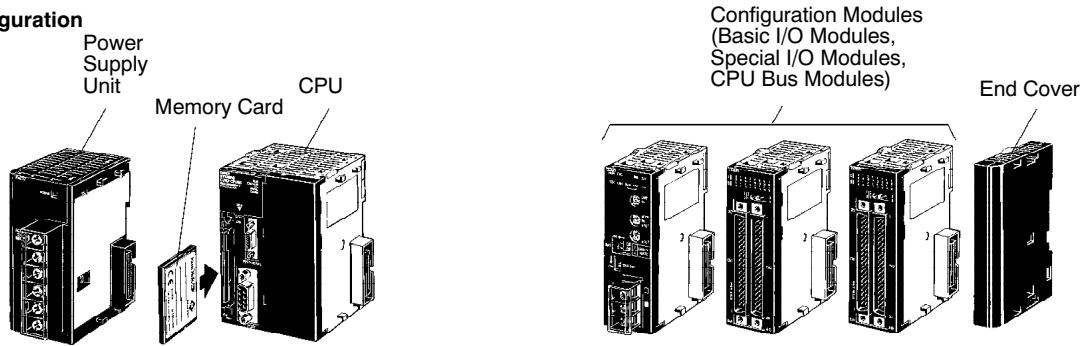

■ CPU and Expansion Racks

If the number of modules per rack exceeds 10 or the current consumption is greater than the capacity of the Power Supply Units, use the CPU and Expansion Rack configuration. This divides the load from the modules across two Power Supply Units. To ensure communication and automatic channel assignment in programming, order an I/O Control Module for the CPU Rack and an I/O Interface Module for the Expansion Rack.

CPU Rack

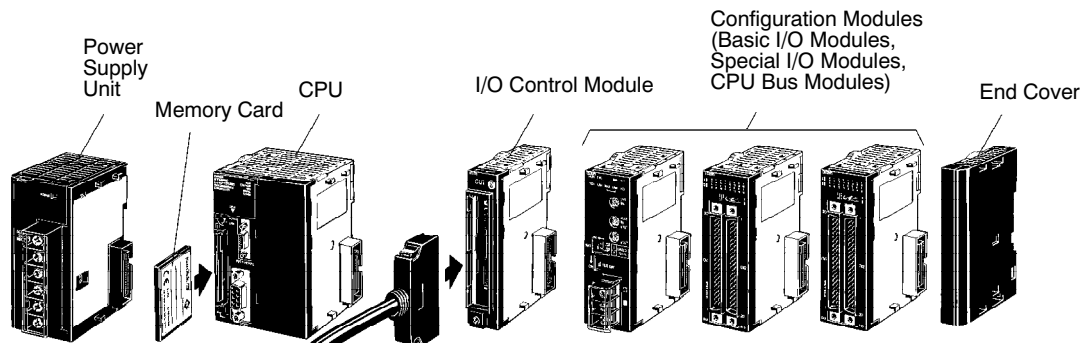

Expansion Rack
(Up to 3 Expansion Racks Allowed)

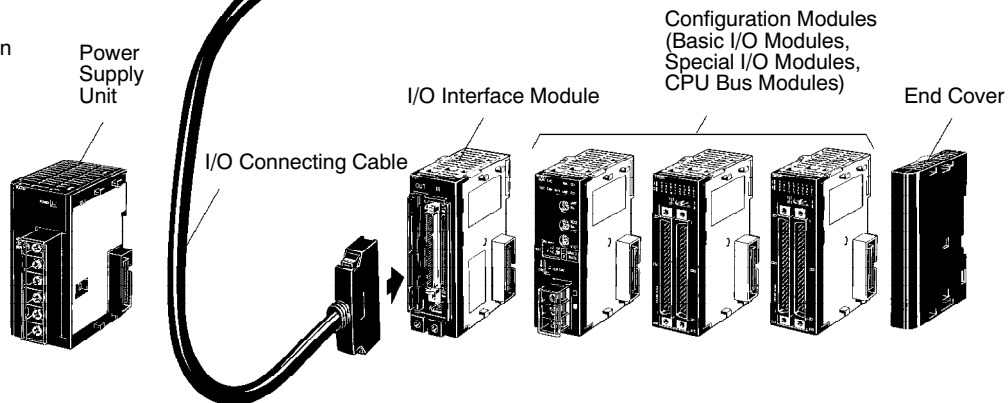

Current Consumption

Calculate All Aspects of Current Consumption

■ Calculating Maximum Current Consumption

A. Calculate Maximum Current Supply (See the table below.)

- Current required at 5 VDC by all Modules in column (A) \leq Maximum current consumption shown in table
- Current required at 24 VDC by all Modules in column (B) \leq Maximum current consumption shown in table
- Current required at 24 VDC for service power supply in column (C) \leq Maximum current consumption shown in table

B. Calculate Maximum Total Power Supply (See the table below.)

- $A \times 5 \text{ VDC} + B \times 24 \text{ VDC} + C \times 24 \text{ VDC} \leq$ Maximum total power consumption shown in column (D)
- The amount of current/power that can be supplied to the Modules mounted in a Rack is limited by the capacity of the Power Supply Unit.
- Design the system so that the total current consumption of the Modules does not exceed the maximum current for each voltage group and the total power consumption does not exceed the maximum for the Power Supply Unit.

Reference Table for Maximum Current Consumption

The following table shows the maximum currents and power that can be supplied by Power Supply Units on CPU Racks and Expansion Racks.

Power Supply Unit	Maximum current consumption			(D) Maximum total power consumption
	(A) 5-V group	(B) 24-V group relay driver power supply	(C) 24-V group service power supply	
CJ1W-PA205R	5.0 A	0.8 A	None	25 W
CJ1W-PA202	2.8 A	0.4 A	None	14 W
CJ1W-PD025	5.0 A	0.8 A	None	25 W

- Note:1. When calculating current/power consumption in a CPU Rack — be sure to include the power required by the CPU itself. When expanding the configuration, be sure to include the power required by the I/O Control Module.
2. When calculating current/power consumption in an Expansion Rack — be sure to include the power required by the I/O Interface Module itself.

■ Example Calculations

In this example, the following modules are mounted to a CJ1 Series CPU Rack with a CJ1W-PA205R Power Supply Unit.

Module	Model	Quantity	5 VDC	24 VDC
CPU	CJ1G-CPU45	1	0.910 A	—
I/O Control Module	CJ1W-IC101	1	0.020 A	—
Input Modules	CJ1W-ID211	2	0.080 A	—
	CJ1W-ID231	2	0.090 A	—
Output Modules	CJ1W-OC201	2	0.090 A	0.048 A
Special I/O Module	CJ1W-DA041	1	0.120 A	—
CPU Bus Module	CJ1W-CLK21	1	0.350 A	—
Current consumption	Calculation		$0.910+0.020+0.080 \times 2+0.090 \times 2+0.090 \times 2+0.120+0.350$	$0.048 \text{ A} \times 2$
	Result		1.92 A ($\leq 5.0 \text{ A}$)	0.096 A ($\leq 0.8 \text{ A}$)
Power consumption	Calculation		$1.92 \times 5 \text{ V} = 9.60 \text{ W}$	$0.096 \text{ A} \times 24 \text{ V} = 2.304 \text{ W}$
	Result		$9.60+2.304 = 11.904 \text{ W} (\leq 25 \text{ W})$	

■ Current Consumption Tables

5-Volt Group: CPUs and Expansion Modules

Module	Model	Current consumption at 5 V (A)
CPUs (These values include current consumption for a Programming Console or CX-Programmer.)	CJ1H-CPU66H/ CJ1H-CPU65H	0.99 (See note.)
	CJ1G-CPU45H/ CJ1G-CPU44H/ CJ1G-CPU43H/ CJ1G-CPU42H	0.91 (See note.)
	CJ1G-CPU45/ CJ1G-CPU44	0.91 (See note.)
	CJ1M-CPU11/ CJ1M-CPU12 CJ1M-CPU13	0.58
	CJ1M-CPU21/ CJ1M-CPU22 CJ1M-CPU23	0.64
	I/O Control Module	CJ1W-IC101
I/O Interface Module	CJ1W-II101	0.13
End Cover (Included in CPU or Expansion Module.)	CJ1W-TER01	—

Note: Add 0.15 A per Module when the NT-AL001-E is connected.

Basic I/O Modules and Interrupt Input Module

Category	Name	Model	Current consumption at 5 V (A)	
Basic Input Modules	DC Input Modules	CJ1W-ID201	0.06	
		CJ1W-ID211	0.08	
		CJ1W-ID231	0.09	
		CJ1W-ID232	0.09	
		CJ1W-ID261	0.09	
		CJ1W-ID262	0.09	
	AC Input Modules	CJ1W-IA111	0.09	
	CJ1W-IA201	0.08		
Basic Output Modules	Transistor	CJ1W-OD201	0.09	
		CJ1W-OD202	0.11	
		CJ1W-OD203	0.10	
		CJ1W-OD204	0.10	
		CJ1W-OD211	0.10	
		CJ1W-OD212	0.10	
		CJ1W-OD231	0.14	
		CJ1W-OD232	0.15	
		CJ1W-OD233	0.14	
		CJ1W-OD261	0.17	
		CJ1W-OD262	0.17	
		CJ1W-OD263	0.17	
		Relay	CJ1W-OC201	0.09
			CJ1W-OC211	0.11
	Triac	CJ1W-OA201	0.22	
	Interrupt Input Module	CJ1W-INT01	0.08	
	Pulse Catch Module	CJ1W-IDP01	0.08	
Mixed	CJ1W-MD231	0.13		
	CJ1W-MD232	0.13		
	CJ1W-MD233	0.13		
	CJ1W-MD261	0.14		
	CJ1W-MD263	0.14		
	CJ1W-MD563	0.19		

Special I/O Modules

Category	Module	Model	Current consumption at 5 V (A)
Special I/O Modules	Analog Input Modules	CJ1W-AD081-V1	0.42
		CJ1W-AD041-V1	0.42
	Analog Output Modules	CJ1W-DA041	0.12
		CJ1W-DA021	0.12
		CJ1W-DA08V	0.14
		CJ1W-DA08C	0.14
	Mixed Analog Module	CJ1W-MAD42	0.58
	Temperature Control Modules	CJ1W-TC□□□□	0.25
	Position Control Modules	CJ1W-NC113/133 CJ1W-NC213/233	0.25
		CJ1W-NC413/433	0.36
	High-speed Counter Module	CJ1W-CT021	0.28
	ID Sensor Modules	CJ1W-V600C11	0.26
CJ1W-V600C12		0.32	

CPU Bus Communication Modules

Category	Name	Model	Current consumption at 5 V (A)
CPU Bus Modules	Ethernet Module	CJ1W-ETN21	0.38
	Controller Link Module	CJ1W-CLK21-V1	0.35
	DeviceNet Module	CJ1W-DRM21	0.33
	ProfiBus-DP Module	CJ1W-PRM21	0.40
		CJ1W-PRT21	0.40
	Serial Communications Module	CJ1W-SCU41	0.38 (See note.)
		CJ1W-SCU21	0.28 (See note.)
	CompoBus/S Master Module	CJ1W-SRM21	0.15

Note: Add 0.15 A per Module when the NT-AL001-E is connected.

24-Volt Group: CJ1 Series Basic Output Modules

Category	Name	Model	Current consumption at 24 V (A)
Basic Output Modules	Relay Output Units	CJ1W-OC201	0.048 (0.006 × No. of points ON)
		CJ1W-OC211	0.096 (0.006 × No. of points ON)

I/O Allocations

Overview

In CJ1 Series PLCs, I/O memory is allocated based on the following: Basic I/O are automatically assigned words based on position in the rack. In contrast, for Communications and Bus I/O, the user assigns the word allocations within set ranges.

Allocations to Basic I/O Module Groups

Allocated words in the CIO Area: CIO 0000 to CIO 0079

Basic I/O Modules can be mounted to the CPU Rack and to the Expansion Racks.

CPU Rack Allocations

Basic I/O Modules on the CPU Rack are allocated words left to right (i.e., from the module nearest the CPU) starting from CIO 0000. Modules are allocated as many words as required in word units. Words can be reserved using CX-Programmer Software.

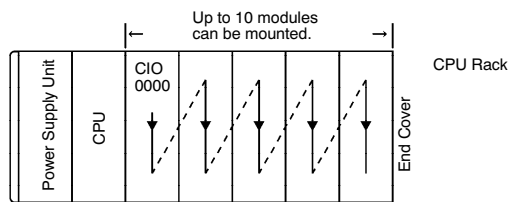

An example of : words allocated from the left.

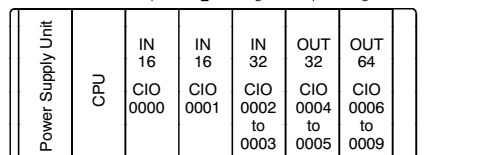

Modules with between 1 and 16 I/O points are allocated 1 word (16 bits), and modules having between 17 and 32 I/O points are allocated 2 words (32 bits). For example, 8-point Relay Modules are allocated 1 word, with bits 00 to 07 actually allocated to the I/O points.

Allocations to Expansion Racks

I/O allocation to Basic I/O Modules continues from the CPU Rack to the Expansion Racks. Words are allocated from left to right, and each module is allocated as many words as it requires in word units— just like modules in the CPU Rack. A Rack's first word setting can be changed to any word from CIO 0000 to CIO 9999.

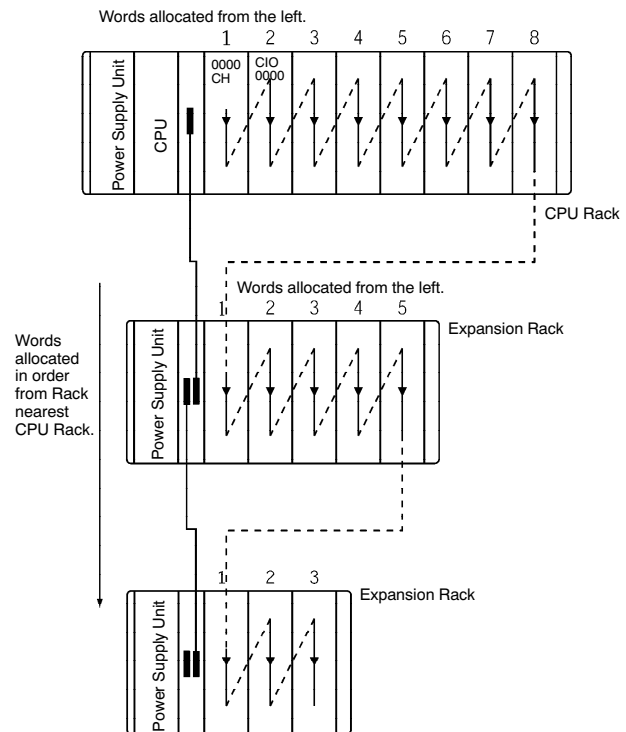

■ CompoBus/S and Special I/O Allocations

When allocating I/O in CPU memory, CompoBus/S is considered a Special I/O Module. These modules can be mounted to the CPU Rack and Expansion Racks. Each CompoBus/S Module is allocated ten words in the Special I/O Module Area (CIO 2000 to CIO 2959). Refer to the table provided to the right.

Note: During I/O allocation to Basic I/O Modules, Special I/O Modules are ignored. (Slots containing Special I/O Modules are treated as empty slots.)

Special I/O Allocations for CompoBus/S

Unit number	Words allocated
0	CIO 2000 to CIO 2009
1	CIO 2010 to CIO 2019
2	CIO 2020 to CIO 2029
⋮	⋮
15	CIO 2150 to CIO 2159
⋮	⋮
95	CIO 2950 to CIO 2959

■ Allocations for All Networking and Communications Modules — Except CompoBus/S

Each CPU Bus Module is allocated 25 words in the CPU Bus Module Area (CIO 1500 to CIO 1899).

CPU Bus Modules can be mounted to the CPU Rack or Expansion Racks.

Each Module is allocated 25 words in the CPU Bus Module Area according to its unit number, as shown in the table to the right.

Note: CPU Bus Modules are ignored during I/O allocation to Basic I/O Modules. The same unit numbers can be used for Special I/O Modules and CPU Bus Modules.

Allocations for All Networking and Communications Modules — Except Special I/O

Unit number	Words allocated
0	CIO 1500 to CIO 1524
1	CIO 1525 to CIO 1549
2	CIO 1550 to CIO 1574
⋮	⋮
15	CIO 1875 to CIO 1899

Power Supply Units

■ Features

Select the Power Supply Unit to match the current consumption requirements of a Basic Configuration CJ1 Series system or a CPU Rack and Expansion Rack system.

- Choose 100-120 VAC/200-240 VAC or 24 VDC models.
- Separate RUN output on CJ1W-PA205R Power Supply Unit provides confirmation of operation for troubleshooting and remote diagnostics.

Power Supply Units
CJ1W-PA205R
CJ1W-PA202
CJ1W-PD025

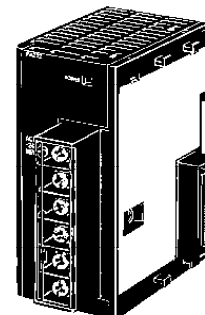

■ Specifications

Item	Specifications		
Power Supply Unit	CJ1W-PA205R	CJ1W-PA202	CJ1W-PD025
Supply voltage	100 to 240 VAC (wide-range), 50/60 Hz		24 VDC
Operating voltage and frequency ranges	85 to 264 VAC, 47 to 63 Hz		19.2 to 28.2 VDC
Power consumption	100 VA max.	50 VA max.	50 W max.
Inrush current (See note 3.)	100 to 120-VAC input: 15 A/8 ms max. (with cold start at room temperature) 200 to 240-VAC input: 30 A/8 ms max. (at cold start under room temperature)	100 to 120-VAC input: 20 A/8 ms max. (with cold start at room temperature) 200 to 240-VAC input: 40 A/8 ms max. (with cold start at room temperature)	At 24 VDC: 30 A/20 ms max. for cold start at room temperature
Output capacity	5.0 A, 5 VDC (including supply to the CPU); 0.8 A, 24 VDC (total: 25 W max.)	2.8 A, 5 VDC (including supply to the CPU); 0.4 A, 24 VDC (total: 14 W max.)	5.0 A, 5 VDC (including supply to the CPU); 0.8 A, 24 VDC;(total: 25 W max.)
Output terminal	Not provided		
RUN output (See note 2.)	Contact configuration: SPST-NO Switching capacity: 250 VAC, 2 A (resistive load) 120 VAC, 0.5 A (inductive load) 24 VDC, 2 A (resistive load) 24 VDC, 2 A (inductive load)	None provided	
Insulation resistance (See note 1.)	20 M Ω min. (at 500 VDC) between AC external and GR terminals		20 M Ω min. (at 500 VDC) between DC external and GR terminals
Dielectric strength (See note 1.)	2,300 VAC 50/60 Hz for 1 min between AC external and GR terminals Leakage current: 10 mA max.		1,000 VAC 50/60 Hz for 1 min between DC external and GR terminals Leakage current: 10 mA max.
	1,000 VAC 50/60 Hz for 1 min between DC external and GR terminals Leakage current: 10 mA max.		

(This table continues on the next page.)

- Note: 1. Disconnect the Power Supply Unit's LG terminal from the GR terminal when testing insulation and dielectric strength. Testing the insulation and dielectric strength with the LG terminal and the GR terminals connected will damage internal circuits in the CPU.
2. Supported only when mounted to CPU Rack.
3. These values are based on the condition that the Unit is cold-started at room temperature. Thermistor elements with current suppression characteristics are used in the inrush current limiting circuits provided in the power supply. The inrush current may exceed as much as twice these values if the ambient temperature is high or when the power supply is hot-started with insufficient cooling down time because the thermistors are not sufficiently cooled down. When selecting fuses or breakers for external circuits, ensure a sufficient allowance for fuse or current detection characteristics.

Specifications (continued)

Item	Specifications
Power Supply Unit	CJ1W-PA205R CJ1W-PA202 CJ1W-PD025
Noise immunity	Conforms to IEC61000-4-4, 2 kV (power lines)
Vibration resistance	10 to 57 Hz, 0.075-mm amplitude, 57 to 150 Hz, acceleration: 9.8 m/s ² in X, Y, and Z directions for 80 minutes. (Time coefficient: 8 minutes × coefficient factor 10 = total time 80 min.)
Shock resistance	147 m/s ² , 3 times each in X, Y, and Z directions (Relay Output Module: 100 m/s ²)
Operating temperature	0 to 55°C
Operating humidity	10% to 90% (with no condensation)
Atmosphere	Must be free from corrosive gases.
Storage temperature	-20 to 75°C (excluding battery)
Grounding	Less than 100 Ω
Enclosure	Mounted in a panel.
Item	Specifications
CJ1 Series CPU Rack dimensions	Refer to "Dimensions" in the <i>Reference</i> Section of this catalog
Dimensions	60 × 90 × 65 mm (W × H × D) power supply only, not including terminal block)
Safety measures	Conforms to cULus and EC directives.

CPU Rack Configuration Checklist

■ CPU Rack Configuration

Item	Products	Requirements
CJ1 Series CPU Rack	CJ1 Series CPU (Provided with 1 End Cover as a standard accessory.)	One of each Module required for every CPU Rack.
	CJ1 Series Power Supply Unit	
	CJ1 Series Basic I/O Module	Total number of Modules: 10 Modules max. (Mounting 11 or more Modules will result in a fatal error.)
	CJ1 Series Special I/O Module	
	CJ1 Series CPU Bus Module	
	End Cover (CJ1W-TER01)	Required on the right-hand side of CJ1 Series CPU Racks. (One End Cover is provided with each CPU as a standard accessory. Not mounting an End Cover on the right-hand side of the CPU Rack will result in a fatal error.)
	Memory Card	Install as required.
	I/O Control Module (CJ1W-IC101)	Required for connection to CJ1 Series Expansion Racks. Connect to the right-hand side of the CPU Rack.
	I/O Connecting Cable	Required for connecting CPU Racks to Expansion Racks.

■ Products Used in CPU Racks

Item	Model	Specifications
CJ1 Series CPUs	CJ1H-CPU66H	I/O bits: 2,560 (3 Expansion Racks), program capacity: 120K steps, LD execution time: 0.02 μs, Data Memory: 256K words (DM: 32K words, EM: 32K words x 7 banks)
	CJ1H-CPU65H	I/O bits: 2,560 (3 Expansion Racks), program capacity: 60K steps, LD execution time: 0.02 μs, Data Memory: 128K words (DM: 32K words, EM: 32K words x 3 banks)
	CJ1G-CPU45H	I/O bits: 1,280 (3 Expansion Racks), program capacity: 60K steps, LD execution time: 0.04 μs, Data Memory: 128K words (DM: 32K words, EM: 32K words x 3 banks)
	CJ1G-CPU44H	I/O bits: 1,280 (3 Expansion Racks), program capacity: 30K steps, LD execution time: 0.04 μs, Data Memory: 64K words (DM: 32K words, EM: 32K words x 1 bank)
	CJ1G-CPU43H	I/O bits: 960 (2 Expansion Racks), program capacity: 20K steps, LD execution time: 0.04 μs, Data Memory: 64K words (DM: 32K words, EM: 32K words x 1 bank)
	CJ1G-CPU42H	I/O bits: 960 (2 Expansion Racks), program capacity: 10K steps, LD execution time: 0.04 μs, Data Memory: 64K words (DM: 32K words, EM: 32K words x 1 bank)
	CJ1M-CPU23	I/O bits: 640 (1 Expansion Rack), program capacity: 20K steps, LD execution time: 0.1 μs, Data Memory: 32K words, (No EM); built-in I/O: 10 inputs, 6 outputs
	CJ1M-CPU22	I/O bits: 320 (No Expansion Racks), program capacity: 10K steps, LD execution time: 0.1 μs, Data Memory: 32K words, (No EM); built-in I/O: 10 inputs, 6 outputs
	CJ1M-CPU21	I/O bits: 160 (No Expansion Racks), program capacity: 5K steps, LD execution time: 0.1 μs, Data Memory: 32K words, (No EM); built-in I/O: 10 inputs, 6 outputs
	CJ1M-CPU13	I/O bits: 640 (1 Expansion Rack), program capacity: 20K steps, LD execution time: 0.1 μs, Data Memory: 32K words, (No EM)
	CJ1M-CPU12	I/O bits: 320 (No Expansion Racks), program capacity: 10K steps, LD execution time: 0.1 μs, Data Memory: 32K words, (No EM)
	CJ1M-CPU11	I/O bits: 160 (No Expansion Racks), program capacity: 5K steps, LD execution time: 0.1 μs, Data Memory: 32K words, (No EM)
	Battery Set	CPM2A-BAT01
CJ1W-BAT01		Can be used with CJ1M only. This battery cannot be used for CJ1G/H or CS1 Series PLCs.
CJ1 Series Power Supply	CJ1W-PA205R	100 to 240 VAC (with RUN output); output capacity: 5 A, 5 VDC
	CJ1W-PA202	100 to 240 VAC; output capacity: 2.8 A, 5 VDC
	CJ1W-PD025	24 VDC; Output capacity: 5 A, 5 VDC
I/O Control Module	CJ1W-IC101	Used to connect a CJ1 Series Expansion Rack to a CJ1 Series CPU Rack. Connect to the right-hand side of the CPU. Connect to an I/O Interface Module mounted on a CJ1 Series Expansion Rack using a CS1/CJ1 Series Connecting Cable.
End Cover	CJ1W-TER01	Required on the right-hand side of CJ1 Series CPU Racks. (Not mounting an End Cover on the right-hand side of the CPU Rack will result in a fatal error.) Note: One is provided with CPUs and I/O Interface Modules as a standard accessory.
Din Track and Accessories	PFP-50N	Length: 50 cm; height: 7.3 mm
	PFP-100N	Length: 1 m; height: 7.3 mm
	PFP-100N2	Length: 1 m; height: 16 mm
	PFP-M	There are two locking clips provided with each CPU and I/O Interface Module as standard accessories to secure the Modules on the DIN Track.

Expansion Rack Configuration Checklist

■ Expansion Rack Configuration

CJ1 Series Expansion Racks can be connected to CJ1 Series CPU Racks or other CJ1 Series Expansion Racks.

Rack	Configuration	Requirements
CJ1 Series Expansion Rack	CJ1 Series Power Supply Unit	One of each Module required for every Expansion Rack. Connect the I/O Interface Module to the right of the Power Supply Unit. Note: An I/O Control Module is required for each CJ1 Series Expansion Rack.
	I/O Interface Module CJ1W-II101 (Provided with 1 End Cover as a standard accessory.)	
	CJ1 Series Basic I/O Module	Total number of Modules: 10 Modules max. (Mounting 11 or more Modules will result in a fatal error.)
	CJ1 Series Special I/O Module	
	CJ1 Series CPU Bus Module	
CS1/CJ1 Series I/O Connecting Cable	Required to connect I/O Control Modules to I/O Interface Modules. Note: The total length of CS1/CJ1 Series I/O Connecting Cable used in the system must not exceed 12 m. Correct operation is not ensured if the total cable length exceeds 12 m.	

■ Capacity Overview

CPU Models	Maximum I/O Modules per CPU (depending on power supply capacity)	Maximum I/O Expansion Racks per CPU (depending on power supply capacity)
CJ1M-CPU13	20	1
CJ1M-CPU23		
CJ1G-CPU42H	30	2
CJ1G-CPU43H		
CJ1G-CPU44H	40	3
CJ1G-CPU45H		
CJ1H-CPU65H		
CJ1H-CPU66H		

■ Products Used in Expansion Racks

Item	Model	Specifications	Cable Length
CJ1 Series Power Supply Unit	CJ1W-PA205R	100 to 240 VAC (with RUN output), output capacity: 5 A, 5 VDC	—
	CJ1W-PA202	100 to 240 VAC, output capacity: 2.8 A, 5 VDC	
	CJ1W-PD025	24 VDC, 5A, 5 VDC	
I/O Interface Module	CJ1W-II101	One is required for each CJ1 Series Expansion Rack. An End Cover is provided as a standard accessory. (Connect to an I/O Control Module on a CPU Rack or to another I/O Interface Module on an Expansion Rack using CS1/CJ1 Series Connecting Cable.)	—
End Cover	CJ1W-TER01	Required for the right-hand side of CJ1 Series Expansion Racks. One is provided with I/O Interface Modules as a standard. (Not connecting an End Cover will result in a fatal error.)	—
CJ1/CS1 Series I/O Connecting Cables	CS1W-CN313	Used to connect I/O Interface Modules (CJ1W-II101) to I/O Control Modules (CJ1W-IC101) or to other I/O Interface Modules.	0.3 m
	CS1W-CN713		0.7 m
	CS1W-CN223		2 m
	CS1W-CN323		3 m
	CS1W-CN523		5 m
	CS1W-CN133		10 m
	CS1W-CN133-B2		12 m

Special Ordering Information

- Order one CJ1W-IC101 I/O Control Module for the CPU rack and one CJ1W-II101 I/O Interface Module for each I/O Expansion rack.
- Connect the modules with a cable of the appropriate length.
- The second and third I/O Expansion racks connect between I/O Interface Modules.

Looking for pricing, stock, or lifecycle information?

Click below to explore more details on WIN SOURCE:

 [View CJ1W-IC101 on WIN SOURCE](#)

 [Omron Information](#)

Optimize Your Supply Chain with WIN SOURCE Solutions

-  Global Sourcing Solution
-  Obsolete Management
-  Cost Control Management
-  Shortage Management
-  Alternative Solution
-  Excess Inventory Management