



**THE DATASHEET OF  
V23826-C18-C363**





# DC/DC (5V/3.3V) V23826-C18-C63/C363

## Single Mode 155 MBd ATM/SDH/SONET 1x9 Transceiver

Preliminary

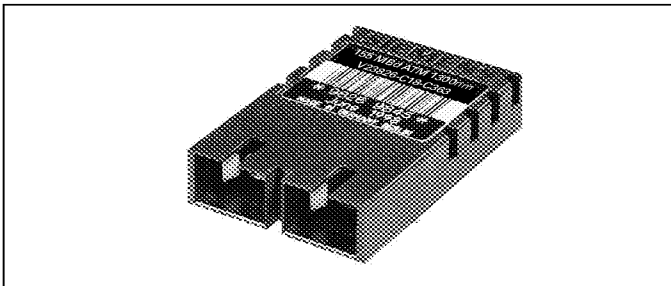
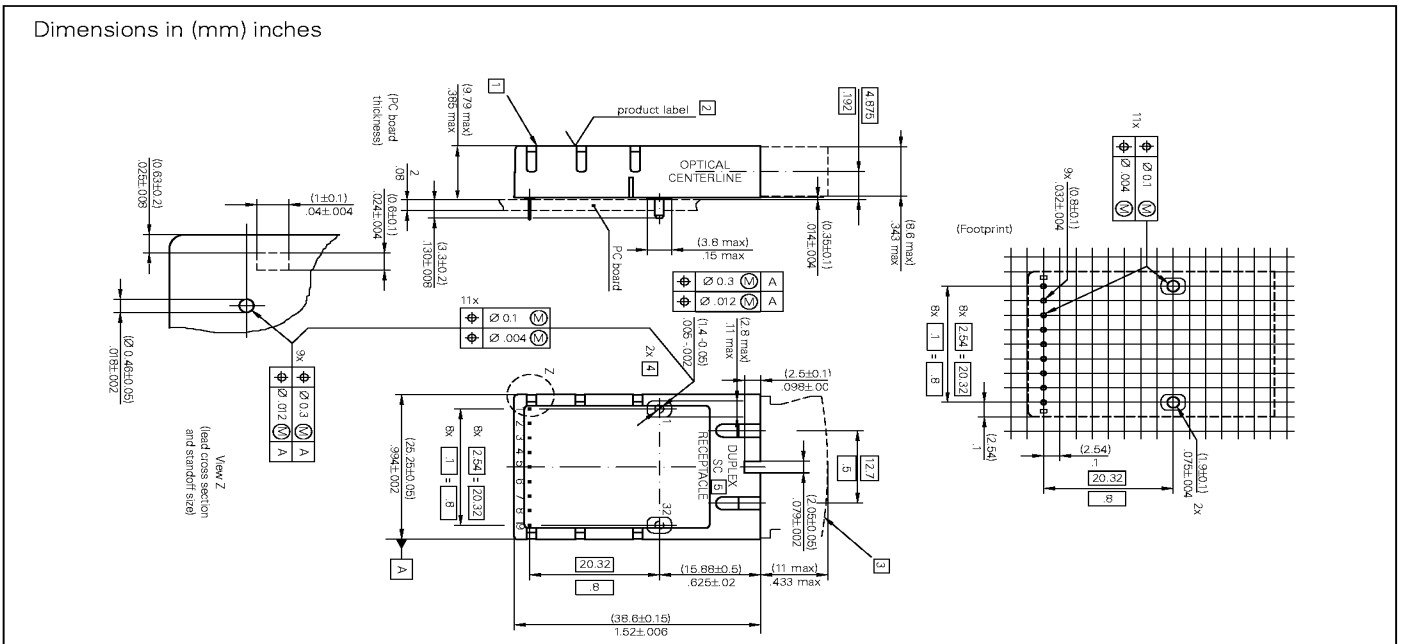

### Absolute Maximum Ratings

Exceeding any one of these values may destroy the device immediately.

Package Power Dissipation <sup>(1)</sup> .....	1.5 W
Supply Voltage (V <sub>CC</sub> -V <sub>EE</sub> ) 5 V .....	7 V
3.3 V .....	5 V
Data Input Levels .....	V <sub>CC</sub> +0.5 V
Differential Data Input Voltage .....	2.5 V
Operating Ambient Temperature .....	0°C to 70°C
Storage Ambient Temperature .....	-40°C to 85°C
Soldering Conditions Temp/Time (MIL-STD 883C, Method 2003) .....	250°C/5.5s

### Note

- For V<sub>CC</sub>-V<sub>EE</sub> (min., max.). 50% duty cycle. The supply current does not include the load drive current of the receiver output.

### FEATURES

- Compliant with ATM, SONET OC-3, SDH STM-1
- Meets mezzanine standard height of 9.8 mm
- Compact integrated transceiver unit with
  - MQW laser diode transmitter
  - InGaAs PIN photodiode receiver
  - Duplex SC receptacle
- Class 1 FDA and IEC laser safety compliant
- FDA Accession No. 9520890-15
- Single power supply (5 V or 3.3 V)
- Signal detect indicator
- PECL differential inputs and outputs
- Process plug included
- Input Signal Monitor
- Wave solderable and washable with process plug inserted
- Industry standard multisource 1x9 footprint
- For distances of min. 15 km on single mode fiber

## DESCRIPTION

The Infineon single mode ATM transceiver complies with the ATM Forum's *Network Compatible ATM for Local Network Applications* document and ANSI's *Broadband ISDN—Customer Installation Interfaces, Physical Media Dependent Specification*, T1.646-1995, Bellcore - SONET OC-3 / IR-1 and ITU-T G. 957 STM-1 / S.1.1.

ATM was developed to facilitate solutions in multimedia applications and real time transmission. The data rate is scalable, and the ATM protocol is the basis of the broadband public networks being standardized in the International Telecommunications Union (ITU), the former International Telegraph and Telephone Consultative Committee (CCITT). ATM can also be used in local private applications.

The Infineon single mode ATM transceiver is a single unit comprised of a transmitter, a receiver, and an SC receptacle. This design frees the customer from many alignment and PC board layout concerns. The module is designed for low cost WAN applications. It can be used as the network end device interface in workstations, servers, and storage devices, and in a broad range of network devices such as bridges, routers, and intelligent hubs, as well as wide area ATM switches.

This transceiver operates at 155.520 Mbits per second from a single power supply (+5 Volt or 3.3 Volt). The differential data inputs and outputs are PECL compatible.

### Functional Description

This transceiver is designed to transmit serial data via single mode cable.

### Functional Diagram

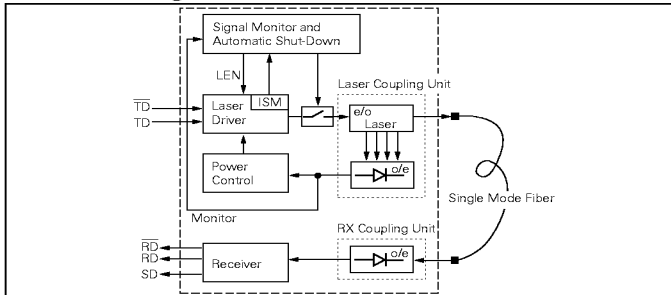

The receiver component converts the optical serial data into PECL compatible electrical data (RD and RDnot). The Signal Detect (SD, active high) shows whether optical data is present<sup>(1)</sup>.

The transmitter converts electrical PECL compatible serial data (TD and TDnot) into optical serial data.

This version contains an Input Signal Monitor (ISM), that switches the optical power off if a continuously low level is applied at Data Input.

### Note

1. We recommend to switch off the transmitter supply ( $V_{CC-Tx}$ ) if no transmitter input data is applied.

The transmitter contains a laser driver circuit that drives the modulation and bias current of the laser diode. The currents are controlled by a power control circuit to guarantee constant output power of the laser over temperature and aging. The power control uses the output of the monitor PIN diode (mechanically built into the laser coupling unit) as a controlling signal, to prevent the laser power from exceeding the operating limits.

Single fault condition is ensured by means of an integrated automatic shutdown circuit that disables the laser when it detects transmitter failures. A reset is only possible by turning the power off, and then on again.

The transceiver contains a supervisory circuit to control the power supply. This circuit generates an internal reset signal whenever the supply voltage drops below the reset threshold. It keeps the reset signal active for at least 15 milliseconds after the voltage has risen above the reset threshold. During this time the laser is inactive.

## TECHNICAL DATA

The electro-optical characteristics described in the following tables are only valid for use under the recommended operating conditions.

### Recommended Operating Conditions

Parameter	Symbol	Min.	Typ.	Max.	Units	
Ambient Temperature	$T_{AMB}$	0		70	°C	
Power Supply Voltage	3.3 V	$V_{CC-V_{EE}}$	3.1	3.3	3.5	V
	5 V		4.75	5	5.25	
Supply Current <sup>(1)</sup>	3.3 V	$I_{CC}$			230	mA
	5 V				270	

### Transmitter

Data Input High Voltage DC/DC	$V_{IH-V_{CC}}$	-1165		-880	mV
Data Input Low Voltage DC/DC	$V_{IL-V_{CC}}$	-1810		-1475	
Input Data Rise/Fall Time 10%–90%	$t_R, t_F$	100		1300	ps

### Receiver

Input Center Wavelength	$\lambda_C$	1270		1355	nm
-------------------------	-------------	------	--	------	----

### Note

1. For  $V_{CC-V_{EE}}$  (min., max.) 50% duty cycle. The supply current does not include the load drive current of the receiver output.

### Transmitter Electro-Optical Characteristics

Transmitter	Symbol	Min.	Typ.	Max.	Units
Launched Power (Average) <sup>(1)</sup>	P <sub>O</sub>	-15	-11	-8	dBm
Center Wavelength	λ <sub>C</sub>	1274		1355	nm
Spectral Width (RMS)	σ <sub>I</sub>			2.5	
Relative Intensity Noise	RIN			-120	dB/Hz
Extinction Ratio (Dynamic)	ER	8.2			dB
Reset Threshold <sup>(2)</sup>	V <sub>TH</sub>		2.7		V
Reset Time Out <sup>(2)</sup>	t <sub>RES</sub>	15	22	35	ms
Eye Diagram <sup>(3)</sup>	ED				

#### Notes

1. Into single mode fiber, 9 μm diameter.
2. Laser power is shut down if power supply is below V<sub>TH</sub> and switched on if power supply is above V<sub>TH</sub> after t<sub>RES</sub>.
3. Transmitter meets ANSI T1E1.2, SONET OC-3 and ITU-T G.957 mask patterns.

### Receiver Electro-Optical Characteristics

Receiver	Symbol	Min.	Typ.	Max.	Units
Sensitivity (Average Power) <sup>(1)</sup>	P <sub>IN</sub>		-33	-31	dBm
Saturation (Average Power)	P <sub>SAT</sub>	-8			
Signal Detect Assert Level <sup>(2)</sup>	P <sub>SDA</sub>			-28	
Signal Detect Deassert Level <sup>(3)</sup>	P <sub>SDD</sub>	-38			
Signal Detect Hysteresis	P <sub>SDA</sub> - P <sub>SDD</sub>	1	tbd	6	dB
Signal Detect Assert Time	t <sub>ASS</sub>			100	μs
Signal Detect Deassert Time	t <sub>DAS</sub>			350	
Output Low Voltage <sup>(4)</sup>	V <sub>OL</sub> - V <sub>CC</sub>	-1950		-1620	mV
Output High Voltage <sup>(4)</sup>	V <sub>OH</sub> - V <sub>CC</sub>	-1025		-720	
Output Data Rise/Fall Time, 20%-80%	t <sub>R</sub> , t <sub>F</sub>			tbd	ps
Return Loss of Receiver	A <sub>RL</sub>	12			dB

#### Notes

1. Minimum average optical power at which the BER is less than 1x10<sup>-12</sup> or lower. Measured with a 2<sup>23</sup>-1 NRZ PRBS as recommended by ANSI T1E1.2, SONET OC-3 and ITU-T G.957.
2. An increase in optical power of data signal above the specified level will cause the SIGNAL DETECT to switch from a Low state to a High state.
3. A decrease in optical power of data signal below the specified level will cause the SIGNAL DETECT to switch from a High state to a Low state.
4. DC/DC, PECL for Signal Detect  
PECL compatible. Load is 50 Ω into V<sub>CC</sub> -2 V for data, 500 Ω to V<sub>EE</sub> for Signal Detect. Measured under DC conditions. For dynamic measurements a tolerance of 50 mV should be added. V<sub>CC</sub>=3.3 V/5 V. T<sub>AMB</sub>=25°C.

### LASER SAFETY

This single mode transceiver is a Class 1 laser product. It complies with IEC 825-1 and FDA 21 CFR 1040.10 and 1040.11. The laser Class 1 is guaranteed within the Absolute Maximum Ratings.

#### Caution

**The use of optical instruments with this product will increase eye hazard!**

#### Usage Restrictions

The optical ports of the modules should be terminated with an optical connector or with a dust plug.

#### Note

Failure to adhere to the above restrictions could result in a modification that is considered an act of "manufacturing," and will require, under law, recertification of the modified product with the U.S. Food and Drug Administration (ref. 21 CFR 1040.10 (i)).

#### Laser Data

Wavelength	1300 nm
Total output power (as defined by IEC: 50 mm aperture at 10 cm distance)	less than 2 mW
Total output power (as defined by FDA: 7 mm aperture at 20 cm distance)	less than 180 μW
Beam divergence	4°

#### Required Labels

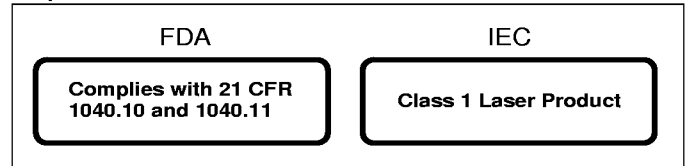

#### Laser Emission

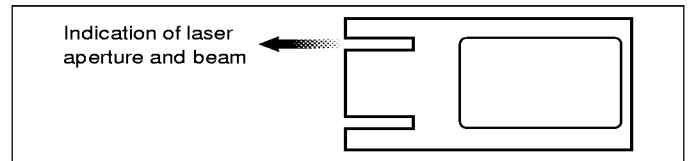

## Pin Description

Pin Name		Level/Logic	Pin#	Description
RxV <sub>EE</sub>	Rx Ground	Power Supply	1	Negative power supply, normally ground
RD	Rx Output Data	PECL Output	2	Receiver output data
RDn			3	Inverted receiver output data
SD	Rx Signal Detect	PECL	4	A high level on this output shows that optical data is applied to the optical input.
RxV <sub>CC</sub>	Rx 3.3 V/5 V	Power Supply	5	Positive power supply, 3.3 V/5 V
TxV <sub>CC</sub>	Tx 3.3 V/5 V		6	
TDn	Tx Input Data	PECL Input	7	Inverted transmitter input data
TD			8	Transmitter input data
TxV <sub>EE</sub>	Tx Ground	Power Supply	9	Negative power supply, normally ground
	Stud Pin	Mech. Support	S1/2	Not connected

## Regulatory Compliance

Feature	Standard	Comments
Electrostatic Discharge (ESD) to the Electrical Pins	MIL-STD 883C Method 3015.4	Class 1 (>1000 V)
Immunity: Electrostatic Discharge (ESD) to the Duplex SC Receptacle	EN 61000-4-2 IEC 1000-4-2	Discharges of $\pm 15$ kV with an air discharge probe on the receptacle cause no damage.
Immunity: Radio Frequency Electromagnetic Field	EN 61000-4-3 IEC 1000-4-3	With a field strength of 3 V/m rms, noise frequency ranges from 10 MHz to 1 GHz. No effect on transceiver performance between the specification limits.
Emission: Electromagnetic Interference EMI	FCC Class B EN 55022 Class B CISPR 22	Noise frequency range: 30 MHz to 6 GHz; Margins depend on PCB layout and chassis design

## APPLICATION NOTE

ATM transceivers and matching circuits are high frequency components and shall be terminated as recommended in the application notes for proper EMI performance. Electromagnetic emission may be caused by these components.

To prevent emissions it is recommended that cutouts for the fiber connectors be designed as small as possible.

It is recommended that the Tx plug and the Rx plug be separated with a bar that divides the duplex SC opening.

## Single Mode 155 MBd ATM 1x9 Transceiver

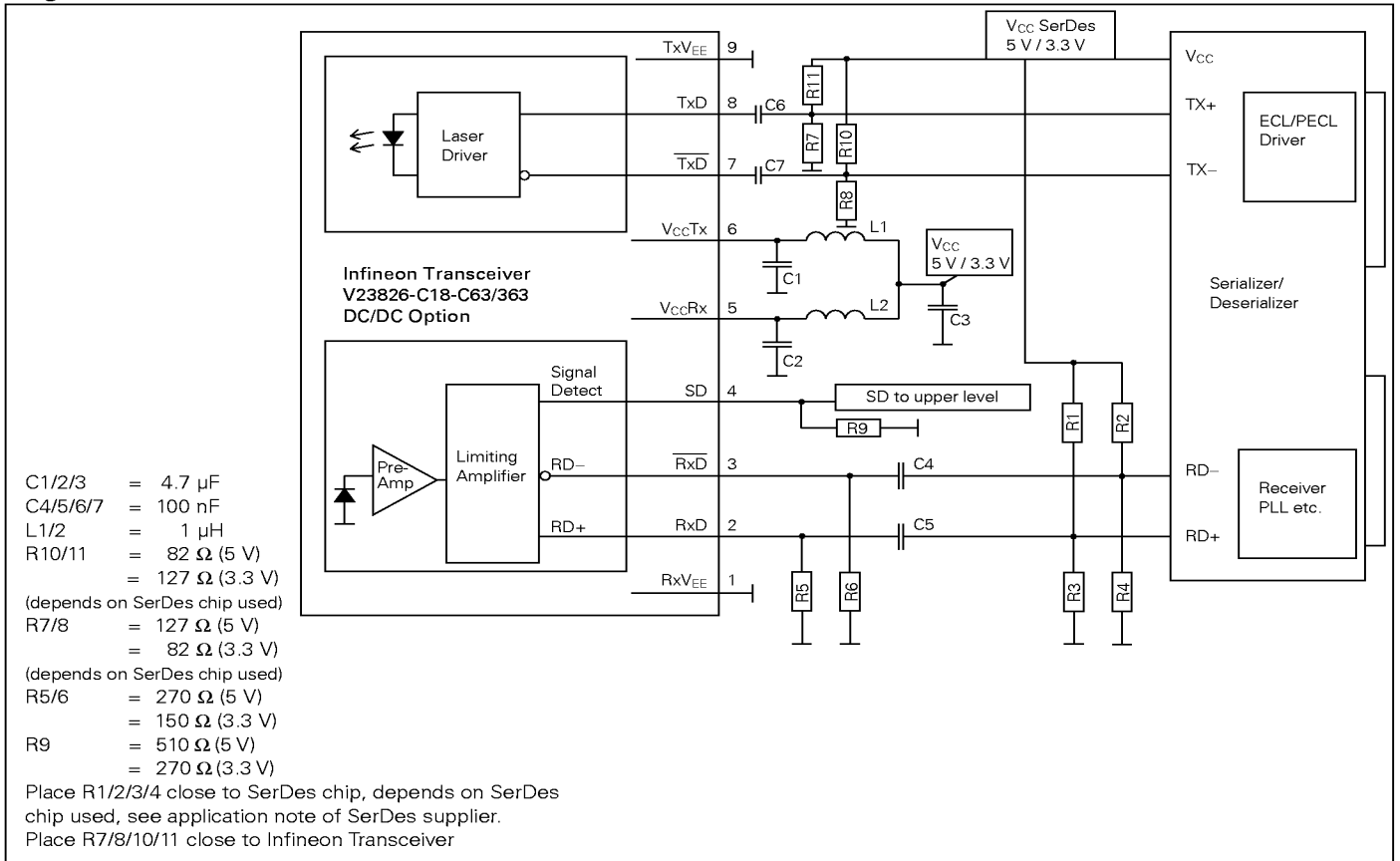

This Application Note assumes Fiber Optic Transceivers using 5 V power supply and SerDes Chips using 3.3 V power supply. It also assumes no self biasing at the receiver data inputs (RD+/RD-) of the SerDes chip (Refer to the manufacturer data sheet for other applications). 3.3 V-Transceivers can be directly connected to SerDes-Chips using standard PECL Termination network.

Value of R1...R4 may vary as long as proper 50  $\Omega$  termination to V<sub>EE</sub> or 100  $\Omega$  differential is provided. The power supply filtering is required for good EMI performance. Use short tracks from

the inductor L1/L2 to the module V<sub>CC</sub>Rx/V<sub>CC</sub>Tx. Further application notes for electrical interfacing are available upon request. Ask for Appnote 82.

We strongly recommend a V<sub>EE</sub> plane under the module for getting good EMI performance.

The transceiver contains an automatic shutdown circuit. Reset is only possible if the power is turned off, and then on again. (V<sub>CC</sub>Tx switched below V<sub>TH</sub>).

Application Board available on request.

Published by Infineon Technologies AG

© Infineon Technologies AG 1999  
All Rights Reserved

### Attention please!

The information herein is given to describe certain components and shall not be considered as warranted characteristics.  
Terms of delivery and rights to technical change reserved.  
We hereby disclaim any and all warranties, including but not limited to warranties of non-infringement, regarding circuits, descriptions and charts stated herein.  
Infineon Technologies is an approved CECC manufacturer.

### Information

For further information on technology, delivery terms and conditions and prices please contact the Infineon Technologies offices or our Infineon Technologies Representatives worldwide - see our webpage at [www.infineon.com/fiberoptics](http://www.infineon.com/fiberoptics)

### Warnings

Due to technical requirements components may contain dangerous substances. For information on the types in question please contact your Infineon Technologies offices.

Infineon Technologies Components may only be used in life-support devices or systems with the express written approval of Infineon Technologies, if a failure of such components can reasonably be expected to cause the failure of that life-support device or system, or to affect the safety or effectiveness of that device or system. Life support devices or systems are intended to be implanted in the human body, or to support and/or maintain and sustain and/or protect human life. If they fail, it is reasonable to assume that the health of the user or other persons may be endangered.

Infineon Technologies AG • Fiber Optics • Wernerwerkdammm 16 • Berlin D-13623, Germany  
Infineon Technologies, Corp. • Fiber Optics • 19000 Homestead Road • Cupertino, CA 95014 USA  
Siemens K.K. • Fiber Optics • Takanawa Park Tower • 20-14, Higashi-Gotanda, 3-chome, Shinagawa-ku • Tokyo 141, Japan

## Looking for pricing, stock, or lifecycle information?

Click below to explore more details on WIN SOURCE:

 [View V23826-C18-C363 on WIN SOURCE](#)

 [Infineon Technologies](#) Information

## Optimize Your Supply Chain with WIN SOURCE Solutions

-  Global Sourcing Solution
-  Obsolete Management
-  Cost Control Management
-  Shortage Management
-  Alternative Solution
-  Excess Inventory Management