



**THE DATASHEET OF
DS1402D-41+**



Features

- Spring-Mounted iButton® Reader
- Momentary Contact for Both F3 and F5 Style iButtons or Dwelled Contact for F5 Only
- Convenient Tactile Feedback System for Dwelled iButton Contact

Mounting Pad Layout

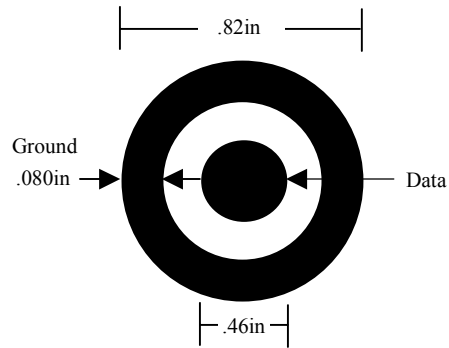

General Description

The four component parts that are used to construct the Blue-Dot™ iButton reader found in the DS1402D-DR8 and DS1402D-DB8 are described here. Diagrams 1 through 4 show the individual part dimensions. This document also describes how to assemble the Blue-Dot given the sub-parts listed in Table 1. The Blue-Dot can be assembled in the three easy steps described in the *Assembly Instructions* section.

Table 1. DS1402D Parts Listing

Reference	Part	Description	Ordering Information
A	DS1402D-011	Small Blue Insert	DS1402D-11
B	DS1402D-010	Small Data Contact Spring	DS1402D-10
C	DS1402D-003	Large Blue Support	DS1402D-3
D	DS1402D-017	Large Ground Contact	DS1402D-17
	DS1402D-041	Subassembly of A-D	DS1402D-41

iButton is a registered trademark of Dallas Semiconductor.
Blue-Dot is a trademark of Dallas Semiconductor.

Diagram 1. DS1402D-003

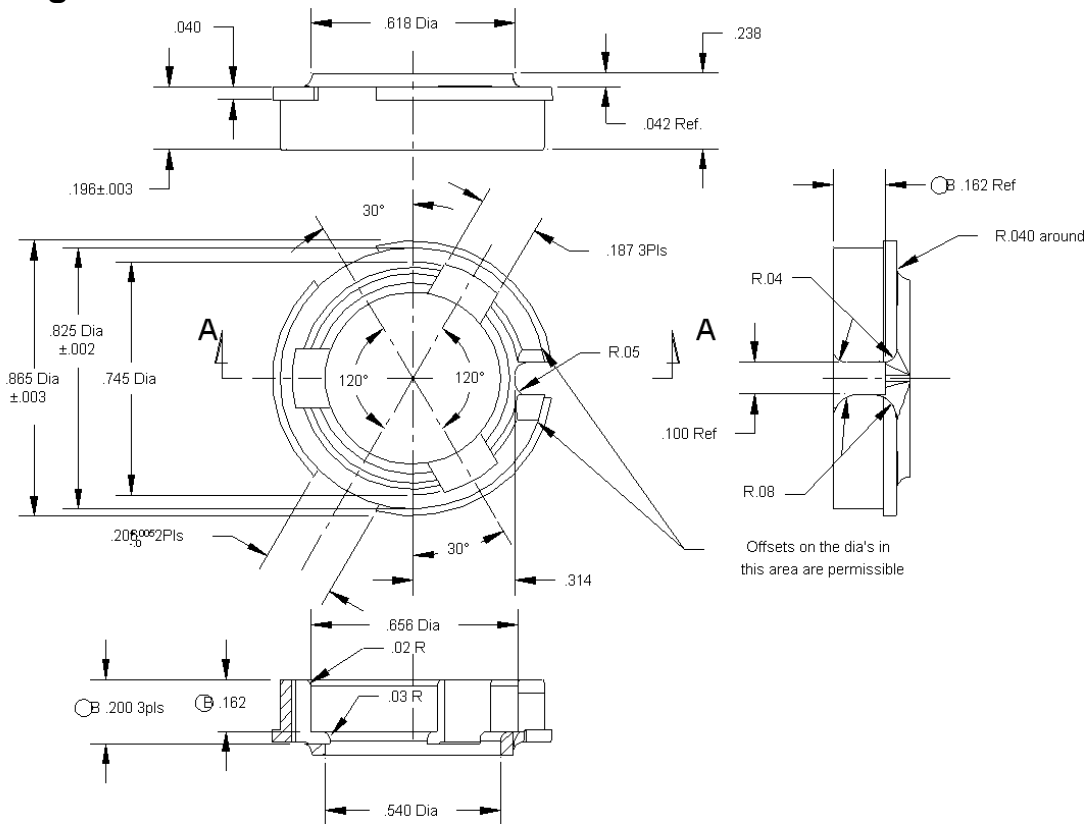

Diagram 2. DS1402D-010

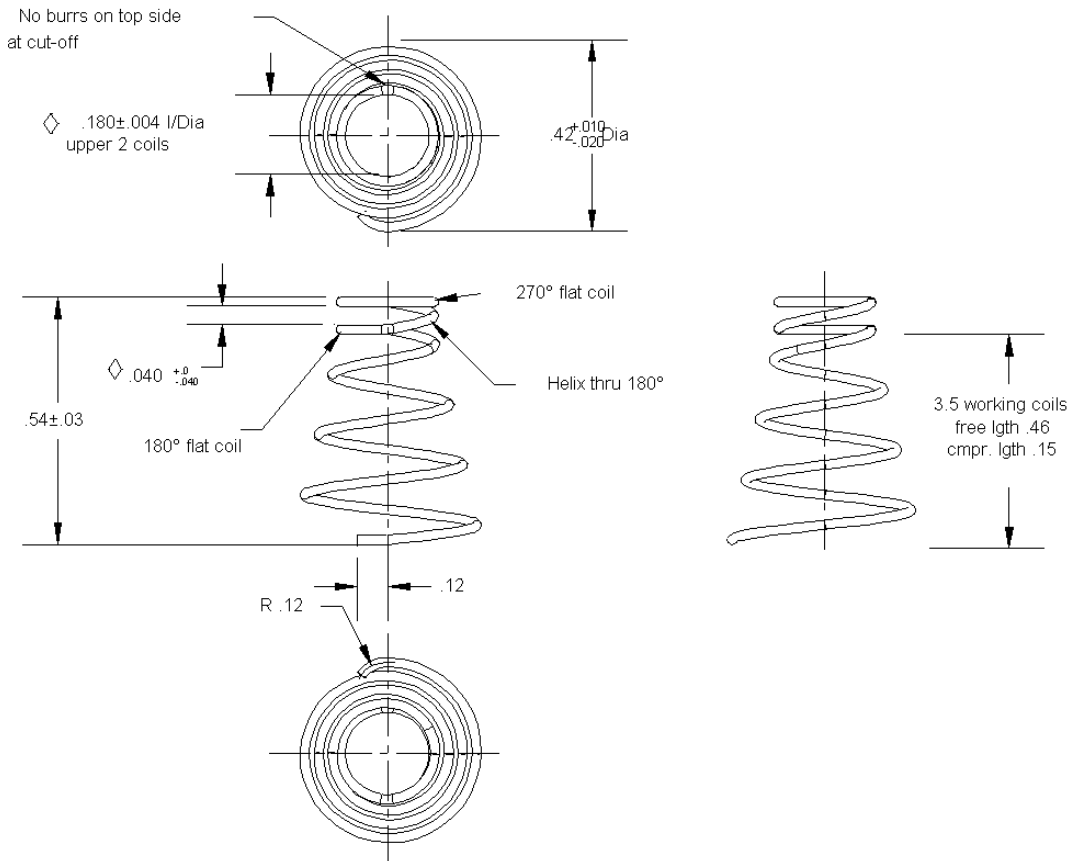

Diagram 3. DS1402D-011

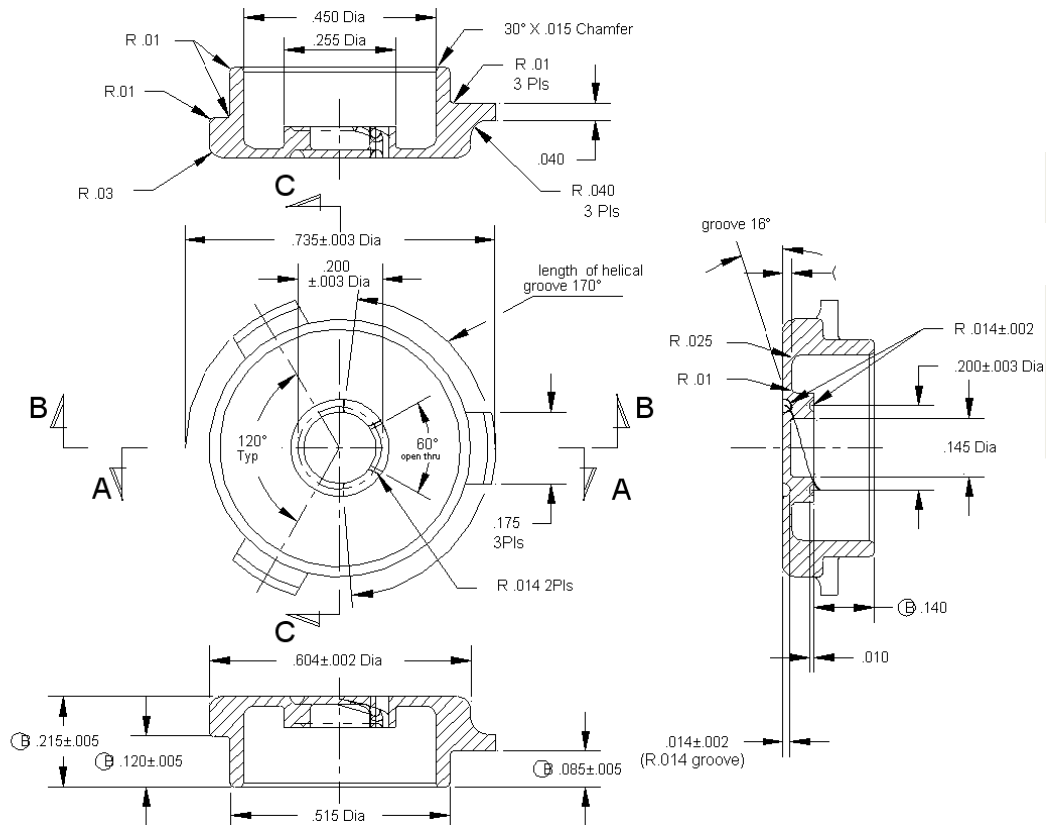
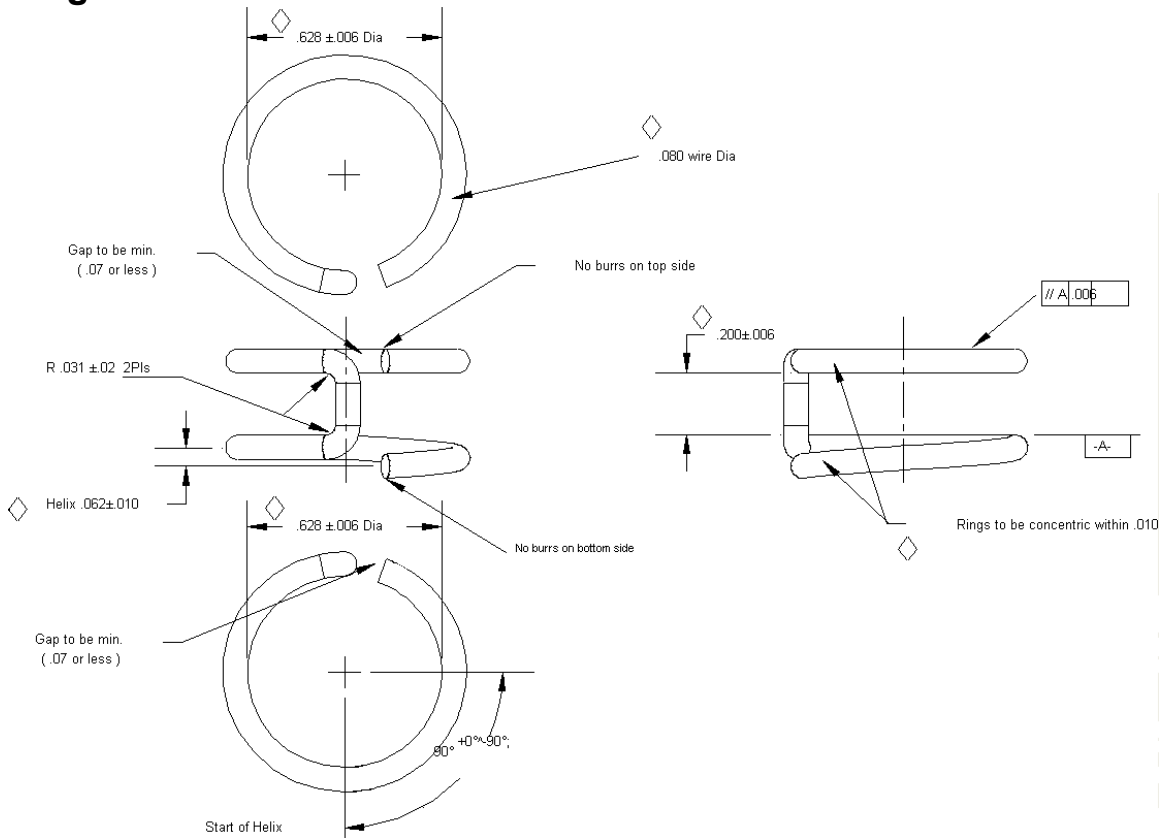
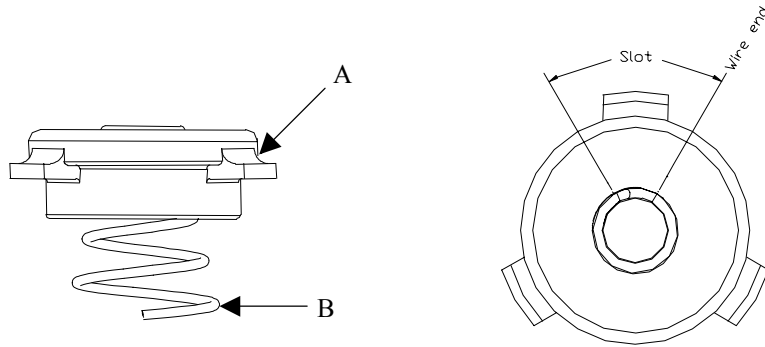

Diagram 4. DS1402D-017



Assembly Instructions

1. Insert the end of the Data Spring (B) wire at the large coil end, into the slot at the top of the Data Button (A). Twist the spring clockwise into the slot until the end of the wire at the small coil end lines up with the edge of the slot in the Button.



2. Place the Data Button (A) with the Data Spring (B), assembled, into the Contact Support (C).

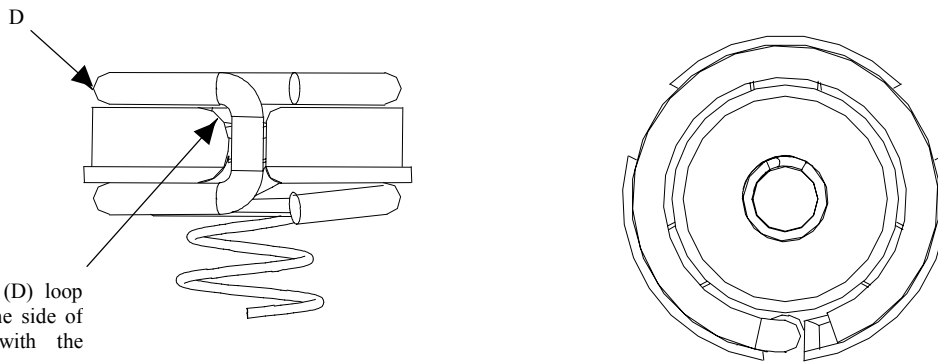

The Contact (D) loop fits around the side of the notch with the larger radii.

3. Compress the Data Spring (B) into the center of the Data Button (A) and slide the Contact (D) onto the Contact Support (C). Check that the Data Button (A) is free to move up and down through the Contact (D).

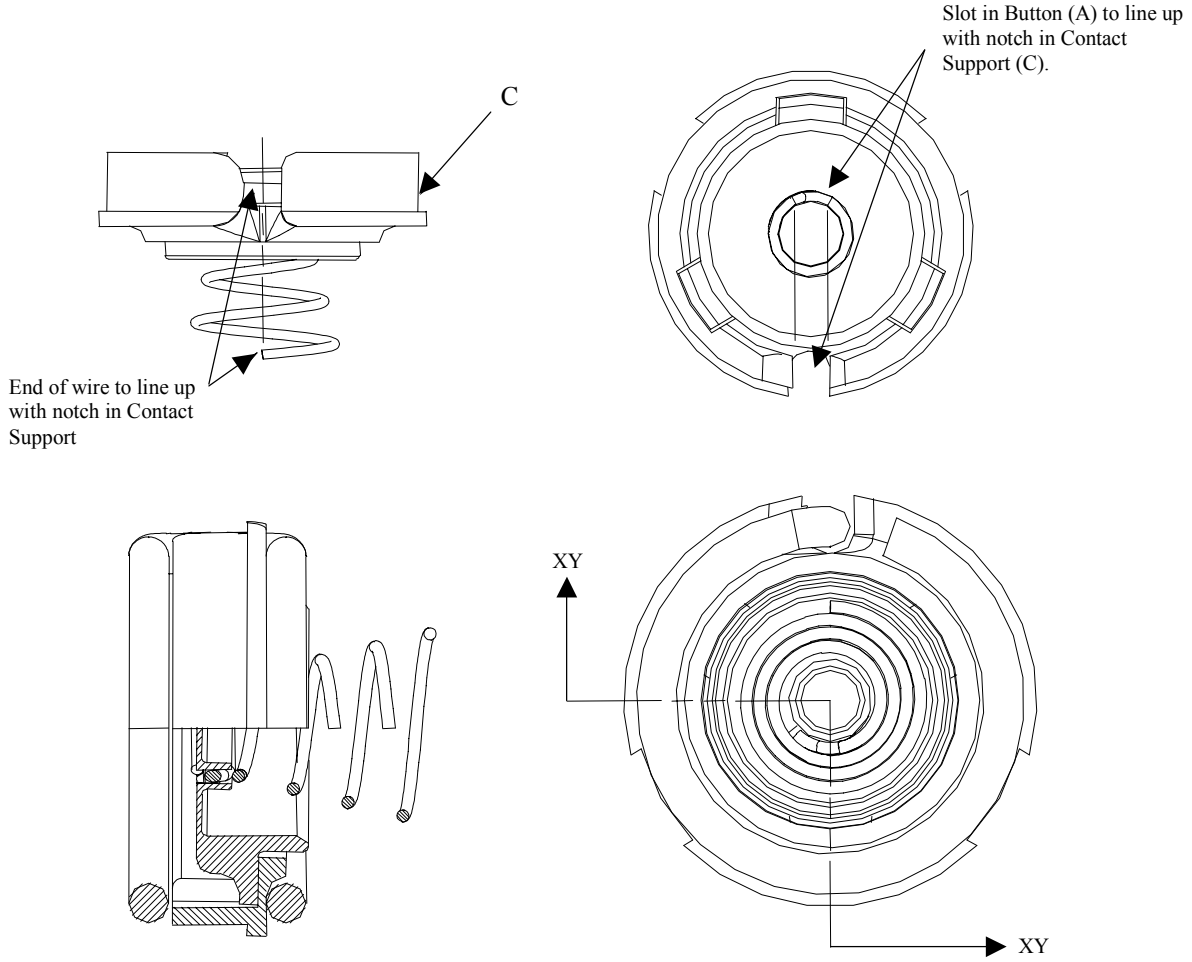

Overview

Here is an assembly picture of the overview of steps listed above.

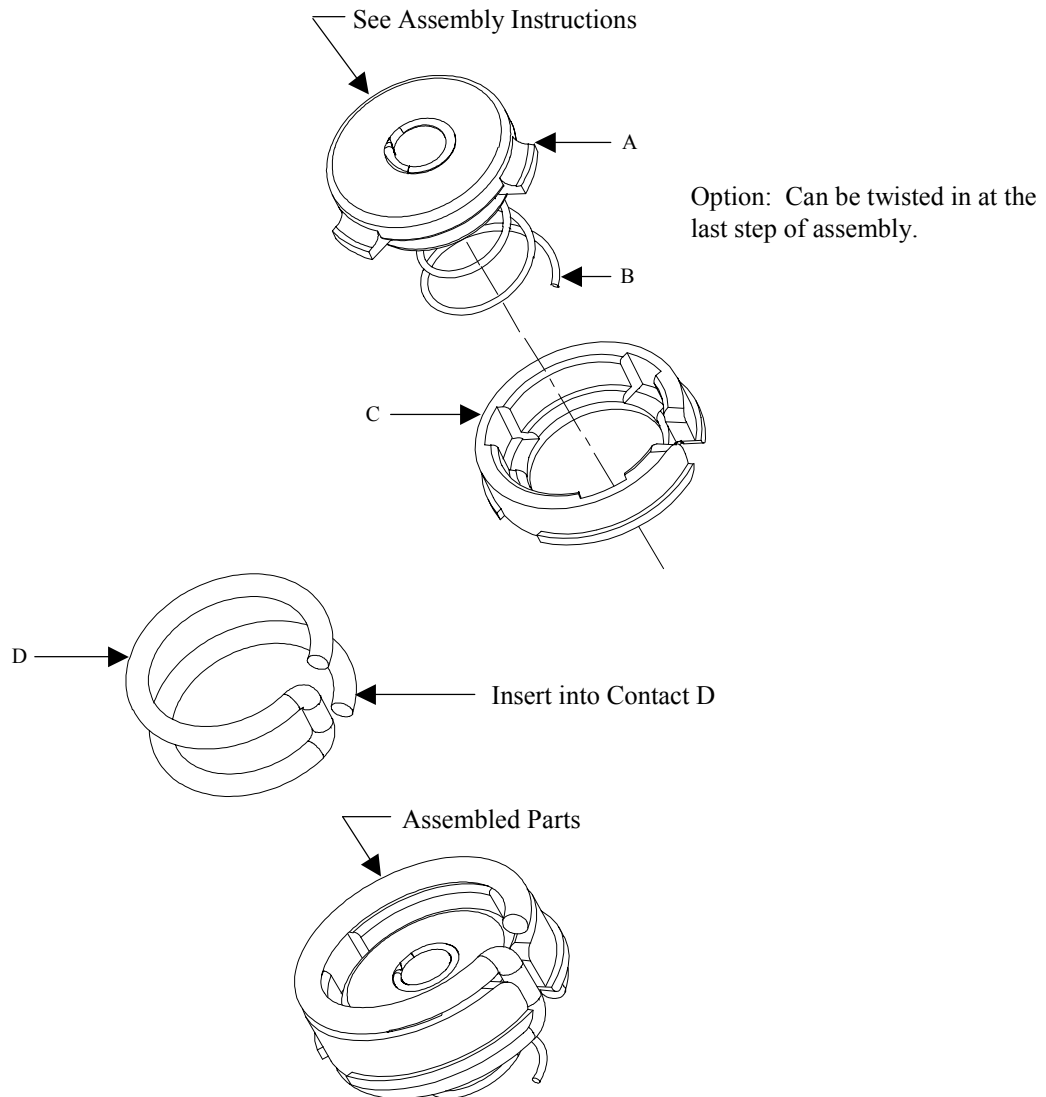

Looking for pricing, stock, or lifecycle information?

Click below to explore more details on WIN SOURCE:

 [View DS1402D-41+ on WIN SOURCE](#)

 [Analog Devices Inc. Information](#)

Optimize Your Supply Chain with WIN SOURCE Solutions

-  Global Sourcing Solution
-  Obsolete Management
-  Cost Control Management
-  Shortage Management
-  Alternative Solution
-  Excess Inventory Management