

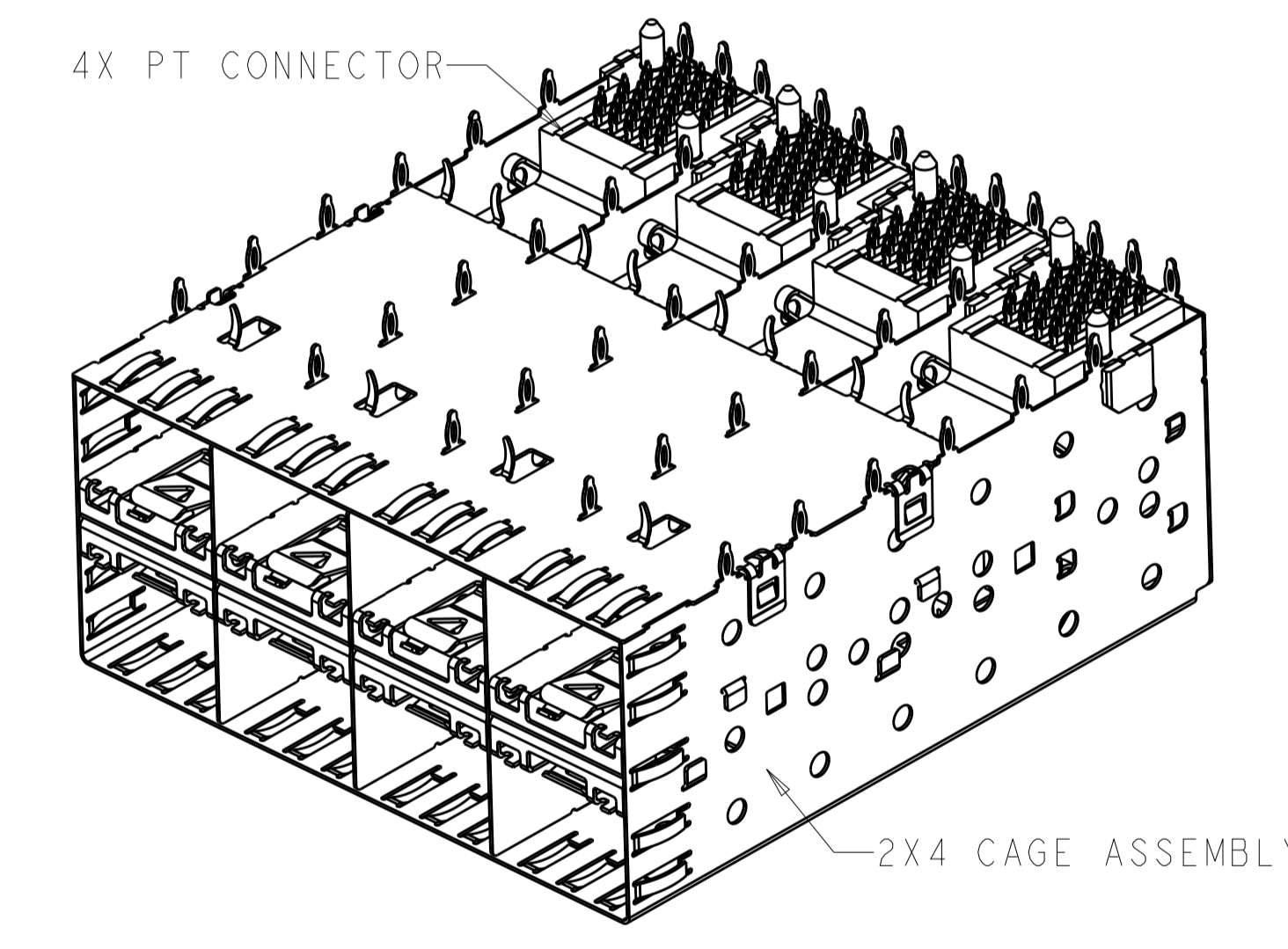

THE DATASHEET OF
1658390-1

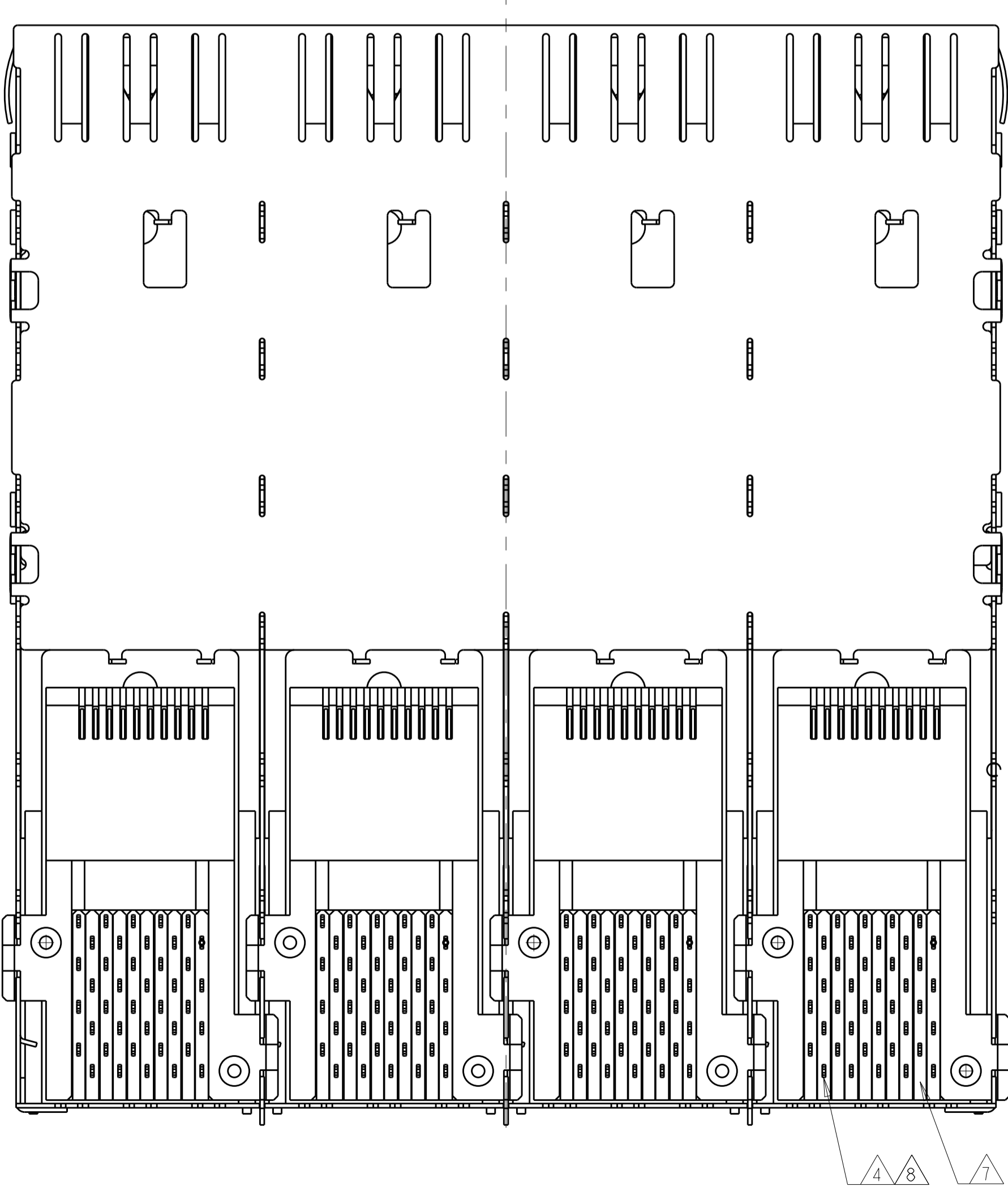

LOC		DIST		REVISIONS			
P	LTN	DESCRIPTION	DATE	DWN	APVD		
D1		REVISED PER ECO-11-005027	18MAR2011	RK	HMR		
F		REVISED PER ECO-14-000886	20FEB2014	JW	SH		
F1		REVISED PER ECO-14-010419	11JUL2014	JW	SH		

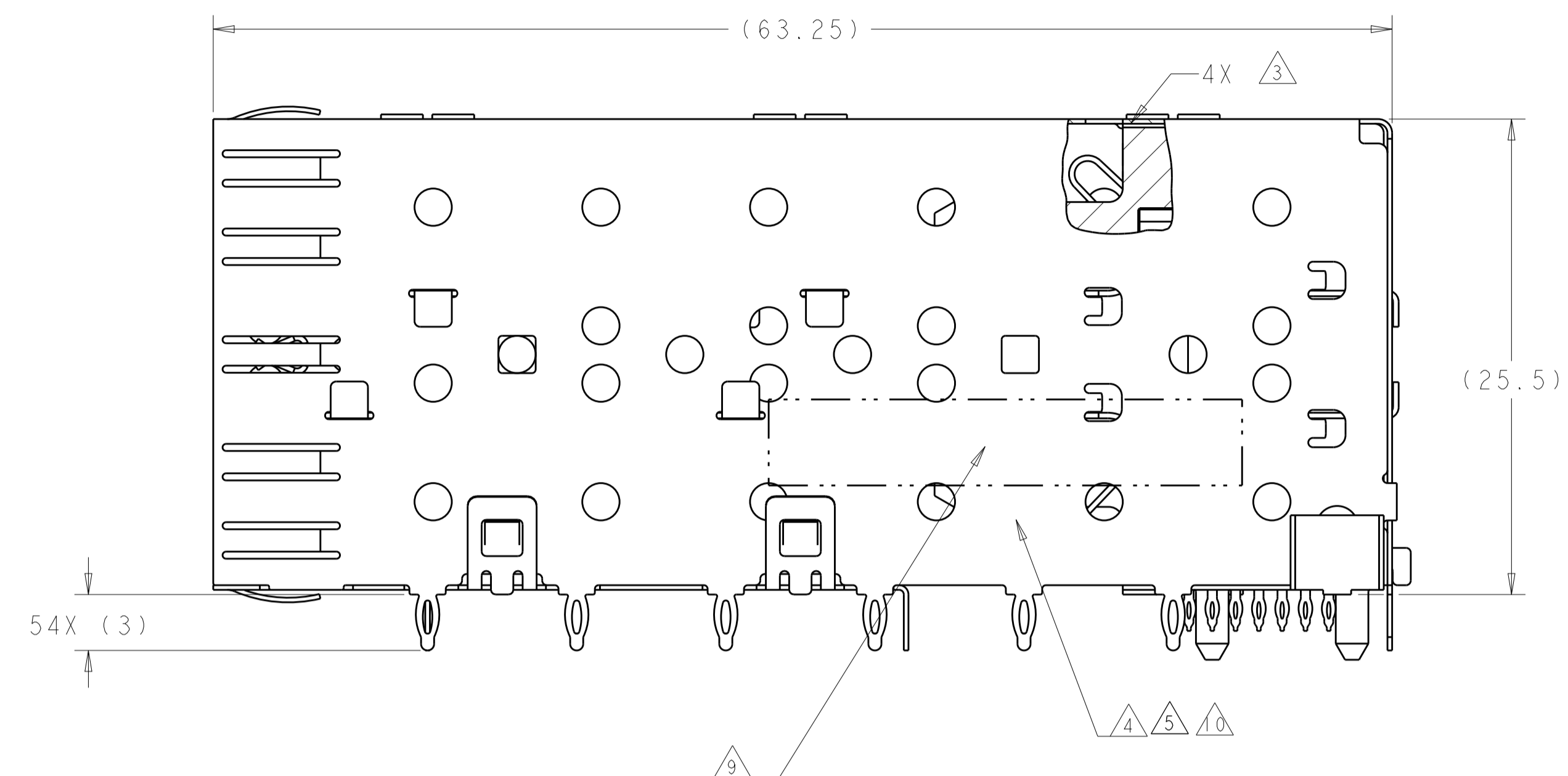
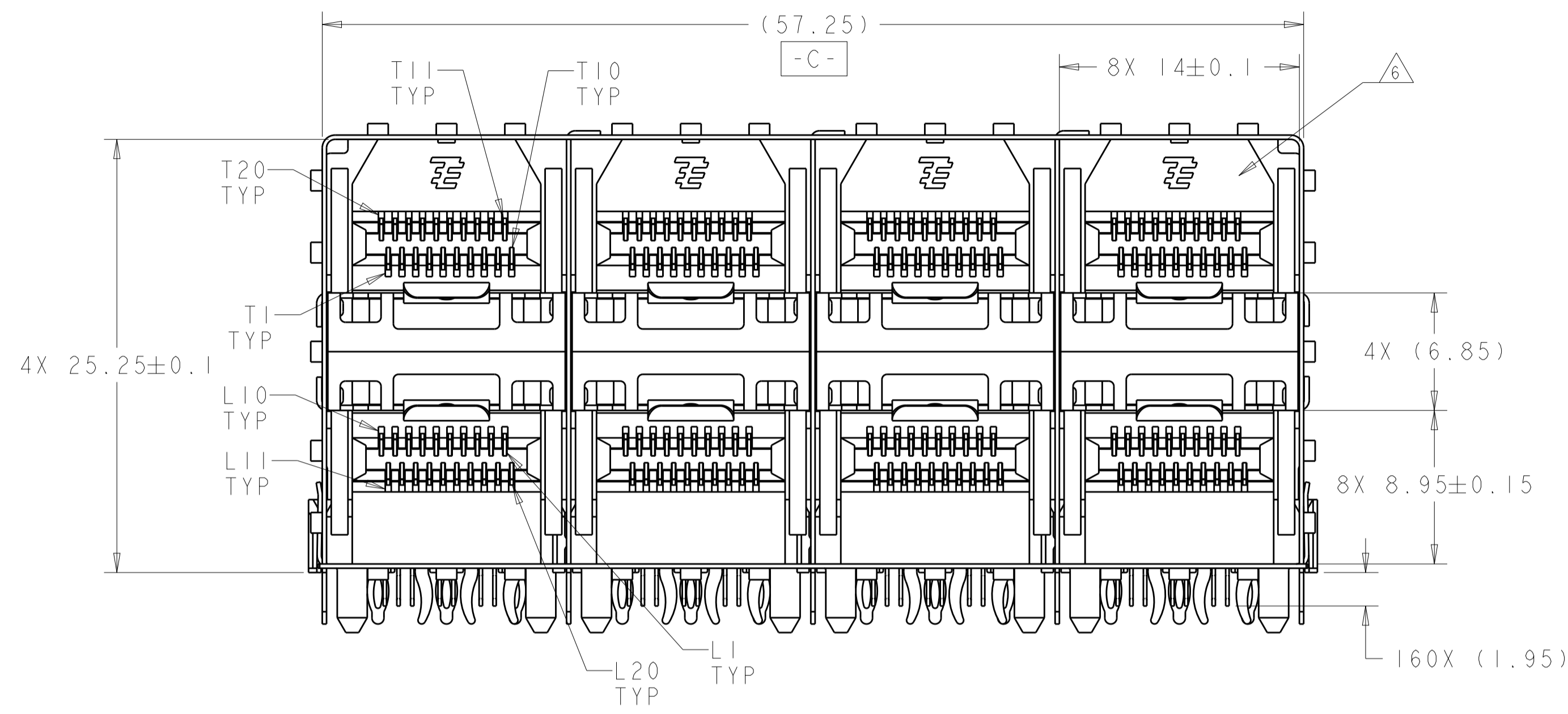

1658390-1&2
SCALE 2:1

- ① DATUM AND BASIC DIMENSION TO BE DETERMINED BY CUSTOMER.
- ② INTERPRETATION OF DATUM REFERENCE FRAME IN ACCORDANCE WITH SECT 4.4.1.1 OF ASME Y14.5M-1994.
- ③ TOP OF PT CONNECTOR TO BE 0-0.15 FROM INSIDE SURFACE OF CAGE.
- ④ COPPER ALLOY.
- ⑤ 1.25µm MIN TIN PER ASTM B 545 OVER NICKEL FLASH PER QQ-N-290. NON-PLATED EDGES PERMISSIBLE.
- ⑥ LCP, HIGH TEMPERATURE, UL 94V-0 RATED, BLACK.
- ⑦ POLYESTER, UL 94V-0 RATED, BLACK.
- ⑧ CONTACT MATING AREA: SURFACE TREATMENT OVER 0.76µm MIN GOLD PER ASTM B 488 OVER 1.27µm MIN NICKEL PER QQ-N-290. NEEDLE EYE: 1.25µm MIN TIN PER ASTM B 545 OVER 1.27µm MIN NICKEL PER QQ-N-290. REMAINDER OF CONTACT: 0.76µm MIN NICKEL PER QQ-N-290.
- ⑨ DATE CODE AND PART NUMBER IN APPROXIMATE AREA SHOWN.
- Ⓜ NICKEL SILVER ALLOY (NO PLATING)

DIMENSIONS:		TOLERANCES UNLESS OTHERWISE SPECIFIED:		MATERIAL FINISH	
mm	0 PLC	±			
	1 PLC	±			
	2 PLC	±0.1			
	3 PLC	±			
	4 PLC	±			
	ANGLES	±			

CONNECTOR FINISH	CONNECTOR MATERIAL	CAGE FINISH	CAGE MATERIAL	PART NUMBER
⑧	④ ⑦	NO	⑩	1658390-2
⑧	④ ⑦	⑤	④	1658390-1

THIS DRAWING IS A CONTROLLED DOCUMENT.		DWN: M. COWHER 24MAR03	NO		⑩	1658390-2
TOLERANCES UNLESS OTHERWISE SPECIFIED:		CHK: J. KOPPENHEFFER 23JAN04	⑤		④	1658390-1
		APVD: M. WALMSLEY 23JAN03	NAME		PT CONNECTOR AND CAGE ASSEMBLY, 2x4, PRESS FIT, STANDARD PROFILE, SFP	
		PRODUCT SPEC: 108-2161	SIZE		A100779C=1658390	
		APPLICATION SPEC: 114-13103	CAGE CODE		DRAWING NO	
		WEIGHT	RESTRICTED TO		SHEET 1 OF 3	
		CUSTOMER DRAWING	SCALE		4:1	

LOC	DIST	REV	DATE	BY	APPV
ES	00				
REVISIONS					
DESCRIPTION			DATE	BY	APPV
SEE SHEET 1					

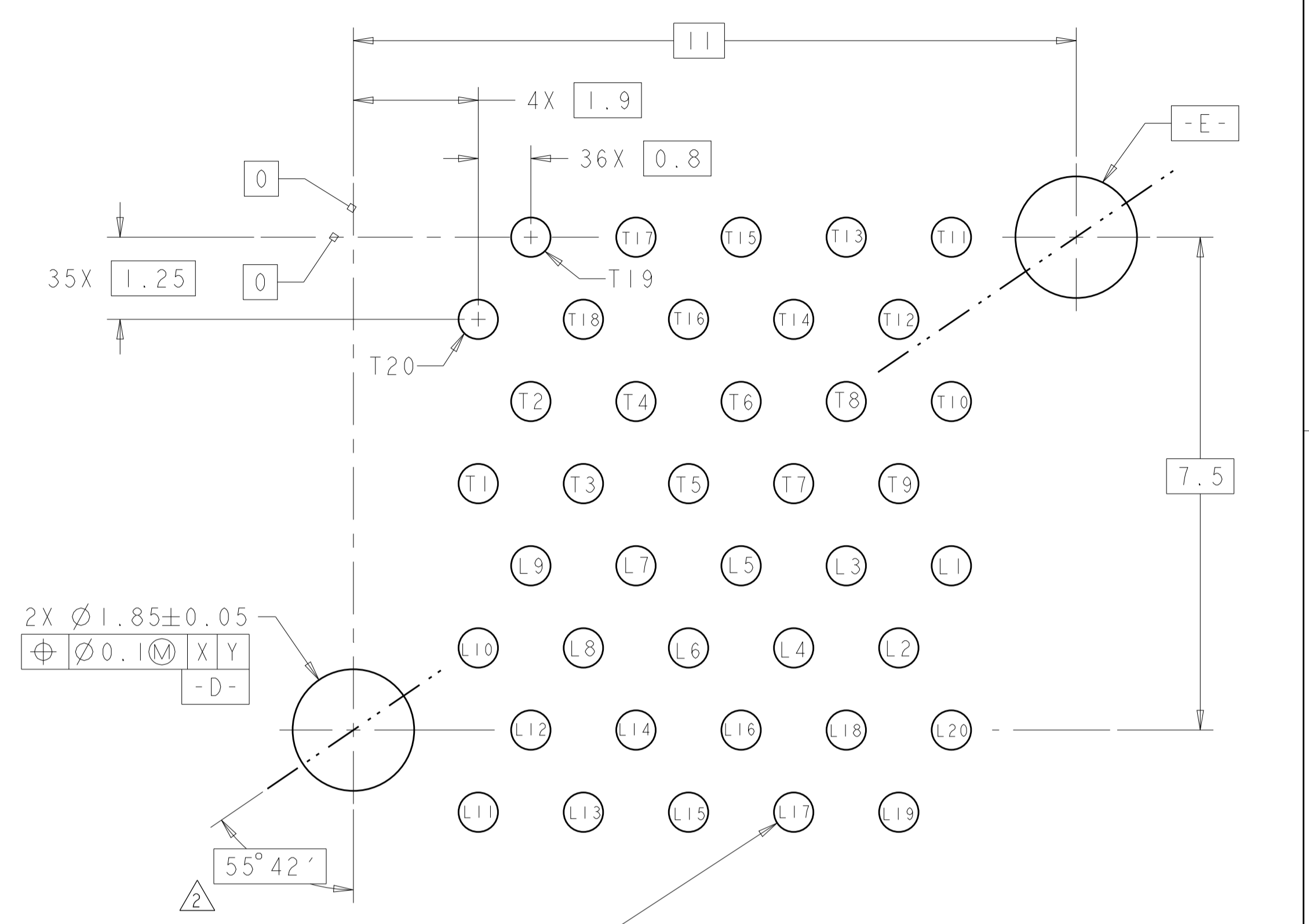
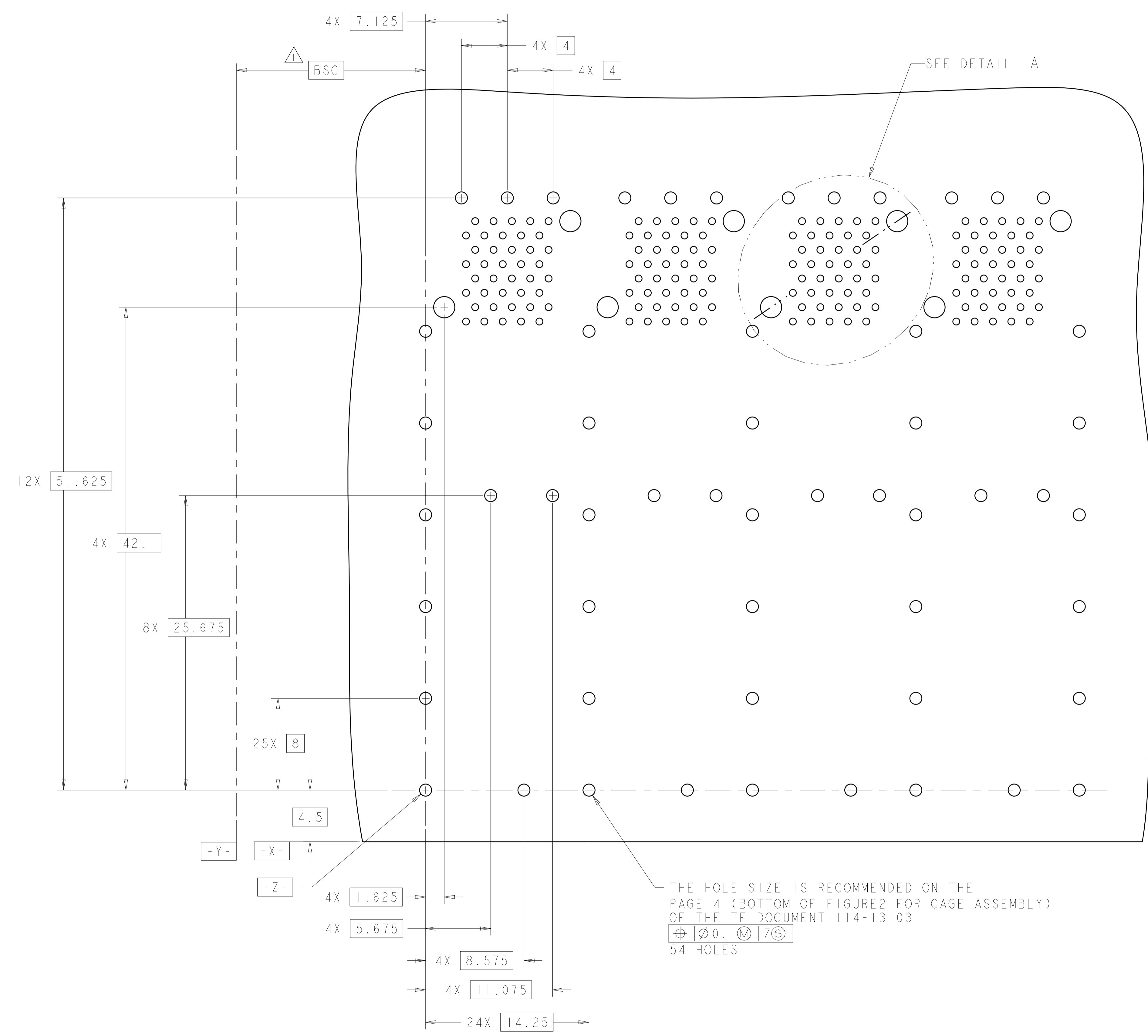

THE HOLE SIZE IS RECOMMENDED ON THE PAGE 4 (TOP OF FIGURE2 FOR CONNECTOR) OF THE TE DOCUMENT 114-13103
 $\text{Ø} \text{Ø}0.08\text{M} \text{DS} \text{ES}$
 40X4 HOLES

DETAIL A
 SCALE 15:1

THE HOLE SIZE IS RECOMMENDED ON THE PAGE 4 (BOTTOM OF FIGURE2 FOR CAGE ASSEMBLY) OF THE TE DOCUMENT 114-13103
 $\text{Ø} \text{Ø}0.1\text{M} \text{ZS}$
 54 HOLES

RECOMMENDED PCB CONFIGURATION
 SCALE 5:1

THIS DRAWING IS A CONTROLLED DOCUMENT.		OWN: M. COWHER 24MAR03	TE Connectivity
DIMENSIONS: mm		CHK: J. KOPPENHEFFER 23JAN04	
TOLERANCES UNLESS OTHERWISE SPECIFIED:		APV: M. WALMSLEY 23JAN03	NAME: PT CONNECTOR AND CAGE ASSEMBLY, 2x4, PRESS FIT, STANDARD PROFILE, SFP
0 PLC ±		PRODUCT SPEC: 108-2161	
1 PLC ±0.1		APPLICATION SPEC: 114-13103	SIZE: A100779 C=1658390 SCALE: 4:1 SHEET 2 OF 3 REV: F1
2 PLC ±		WEIGHT: -	
3 PLC ±		CUSTOMER DRAWING	
4 PLC ±			
ANGLES ±			
FINISH			

LOC	DIST	REVISIONS					
ES	00	P	LTN	DESCRIPTION	DATE	DWN	APVD
		-		SEE SHEET 1	-	-	-

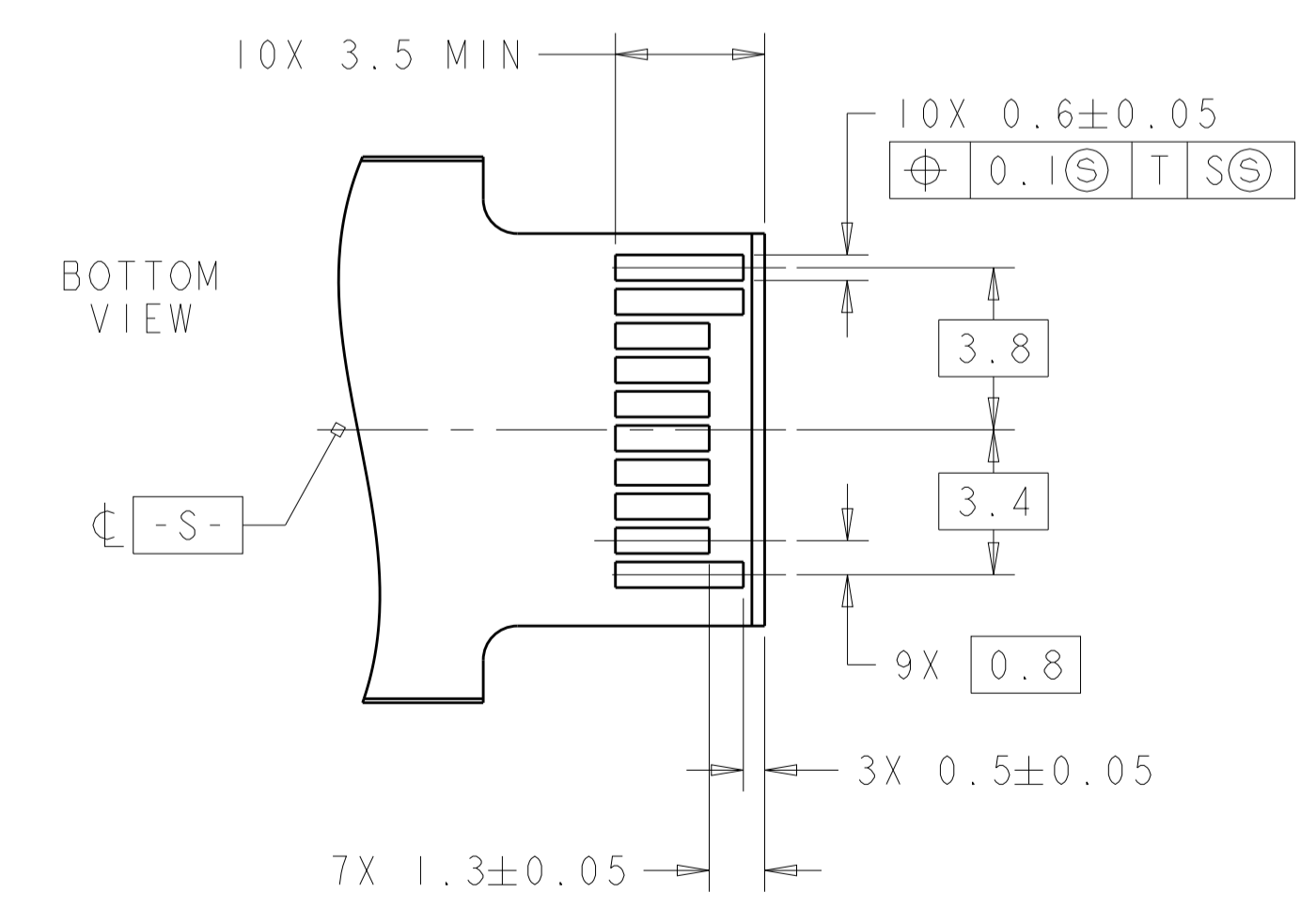
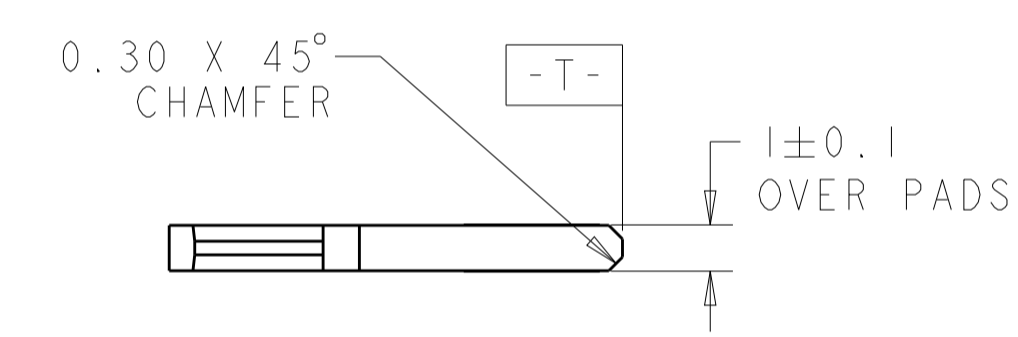
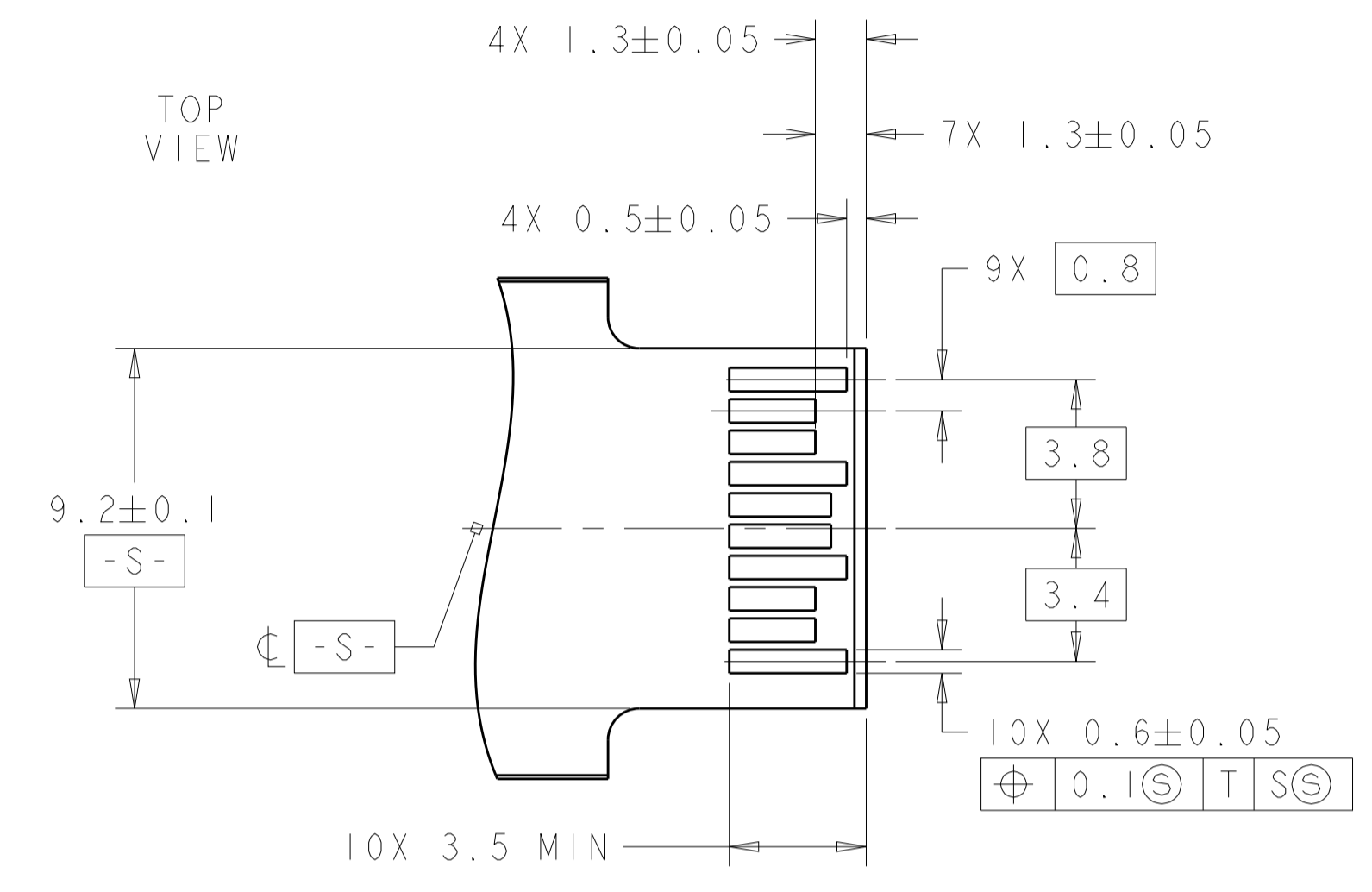

RECOMMENDED LAYOUT FOR
 MATING TRANSCEIVER PCB
 SCALE 6:1

THIS DRAWING IS A CONTROLLED DOCUMENT.		DWN M. COWHER	ZAMAR03	 TE Connectivity
DIMENSIONS: mm		CHK J. KOPPENHEFFER	23JAN04	
TOLERANCES UNLESS OTHERWISE SPECIFIED:		APVD M. WALMSLEY	23JAN03	NAME PT CONNECTOR AND CAGE ASSEMBLY, 2x4, PRESS FIT, STANDARD PROFILE, SFP
0 PLC ± 1 PLC ± 2 PLC ±0.1 3 PLC ± 4 PLC ± ANGLES ±		PRODUCT SPEC 108-2161		SIZE 114-13103
MATERIAL		FINISH	WEIGHT	RESTRICTED TO
				A100779C=1658390
		CUSTOMER DRAWING		SCALE 1:1 SHEET 3 OF 3 REV F1

Looking for pricing, stock, or lifecycle information?

Click below to explore more details on WIN SOURCE:

 [View 1658390-1](#) on WIN SOURCE

 [TE Connectivity](#) Information

Optimize Your Supply Chain with WIN SOURCE Solutions

-  Global Sourcing Solution
-  Obsolete Management
-  Cost Control Management
-  Shortage Management
-  Alternative Solution
-  Excess Inventory Management