



**THE DATASHEET OF
DF11-2428SCA**



SN6505x-Q1 Low-Noise 1-A Transformer Drivers for Isolated Power Supplies

1 Features

- AEC-Q100 (Grade 1) qualified for automotive applications
 - Device temperature grade 1: -40°C to $+125^{\circ}\text{C}$, T_A
- **Functional Safety-Capable**
 - Documentation available to aid functional safety system design: [SN6505A-Q1](#), [SN6505B-Q1](#), [SN6505D-Q1](#)
- Push-pull driver for transformers
- Wide input voltage range: 2.25 V to 5.5 V
- High output drive: 1 A at 5 V supply
- Low R_{ON} 0.25 Ω max at 4.5 V supply
- Reduced conducted and radiated EMI
- Spread spectrum clocking
- Precision internal oscillator options: 160 kHz (SN6505A-Q1) and 420 kHz (SN6505B-Q1 and SN6505D-Q1)
- Synchronization of multiple devices with external clock input
- Slew-rate control
- 1.7 A Current-limit
- Low shutdown current: $<1\ \mu\text{A}$
- Thermal shutdown
- Small 6-Pin SOT23 (DBV) package
- Soft-start enabled (SN6505A-Q1 and SN6505B-Q1) to reduce in-rush current and soft-start disabled (SN6505D-Q1) for fast start-up

2 Applications

- Isolated power supplies for
 - Traction inverter and motor control
 - DC/DC converter
 - Battery management system (BMS)
 - On-board charger (OBC)

3 Description

The SN6505x-Q1 is a low-noise, low-EMI push-pull transformer driver, specifically designed for small form factor, isolated power supplies. It drives low-profile, center-tapped transformers from a 2.25 V to 5 V DC power supply. Very low noise and EMI are achieved by slew rate control of the output switch voltage and through Spread Spectrum Clacking (SSC). The SN6505x-Q1 consists of an oscillator followed by a gate drive circuit that provides the complementary output signals to drive ground-referenced N-channel power switches. The device

includes two 1-A Power-MOSFET switches to ensure start-up under heavy loads. The switching clock can also be provided externally for accurate placement of switcher harmonics, or when operating with multiple transformer drivers. The internal protection features include a 1.7 A current limiting, under-voltage lockout, thermal shutdown, and break-before-make circuitry. SN6505A-Q1 and SN6505B-Q1 include a soft-start feature that prevents high inrush current during power up with large load capacitors. Soft-start feature has been disabled in SN6505D-Q1 for applications that require fast output start-up. SN6505A-Q1 has a 160 kHz internal oscillator for applications that need to minimize emissions whereas SN6505B-Q1 and SN6505D-Q1 have a 420 kHz internal oscillators for applications that require higher efficiency and smaller transformer size. The SN6505x-Q1 is available in a small 6-pin SOT23/DBV package. The device operation is characterized for a temperature range from -40°C to 125°C .

Device Information

PART NUMBER (1)	PACKAGE	BODY SIZE (NOM)
SN6505A-Q1	SOT23 (6 Pin)	2.90 mm × 1.60 mm
SN6505B-Q1		
SN6505D-Q1		

(1) For all available packages, see the orderable addendum at the end of the datasheet.

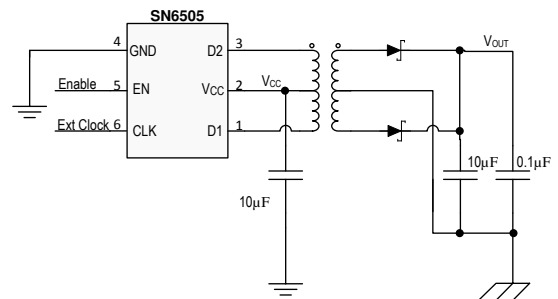

Copyright © 2016, Texas Instruments Incorporated

Simplified Schematic



Table of Contents

1 Features	1	8.4 Device Functional Modes.....	17
2 Applications	1	9 Application and Implementation	18
3 Description	1	9.1 Application Information.....	18
4 Revision History	2	9.2 Typical Application.....	19
5 Pin Configuration and Functions	3	10 Power Supply Recommendations	29
6 Specifications	4	11 Layout	30
6.1 Absolute Maximum Ratings.....	4	11.1 Layout Guidelines.....	30
6.2 ESD Ratings.....	4	11.2 Layout Example.....	30
6.3 Recommended Operating Conditions.....	4	12 Device and Documentation Support	31
6.4 Thermal Information.....	4	12.1 Device Support.....	31
6.5 Electrical Characteristics.....	5	12.2 Documentation Support.....	31
6.6 Timing Requirements.....	6	12.3 Related Links.....	31
6.7 Typical Characteristics, SN6505A-Q1	7	12.4 Receiving Notification of Documentation Updates..	31
6.8 Typical Characteristics, SN6505B-Q1 or SN6505D-Q1	9	12.5 Support Resources.....	31
7 Parameter Measurement Information	13	12.6 Trademarks.....	31
8 Detailed Description	15	12.7 Electrostatic Discharge Caution.....	31
8.1 Overview.....	15	12.8 Glossary.....	32
8.2 Functional Block Diagram.....	15	13 Mechanical, Packaging, and Orderable Information	32
8.3 Feature Description.....	15		

4 Revision History

Changes from Revision C (August 2019) to Revision D (October 2020)	Page
• Added Funtional Safety Bullets.....	1
<hr/>	
Changes from Revision B (July 2019) to Revision C (August 2019)	Page
• Added UNIT V to EN, CLK Voltage specification in Absolute Maximum Ratings table.....	4
• Changed '<' or 'less than' sign to '≤' or 'less than or equal' sign in V _{CC} range description at multiple location for better clarity.....	5
• Added Revision History comments for data sheet Revision B.....	6
• Added 'Power up time' or t _{PWRUP} specification for two V _{CC} TEST CONDITIONS.....	6
<hr/>	
Changes from Revision A (April 2019) to Revision B (July 2019)	Page
• Split 'Soft-start time' or t _{SS} specification for SN6505A-Q1 and SN6505B-Q1.....	6
<hr/>	
Changes from Revision * (November 2018) to Revision A (April 2019)	Page
• Changed device status to "Production Data"	1
• Added DA2303-AL transformer to Table 9-3 table.....	25
• Added DA2304-AL transformer to Table 9-3 table.....	25

5 Pin Configuration and Functions

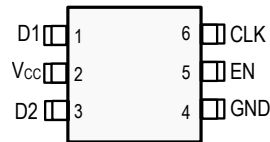

Figure 5-1. DBV Package SOT-23 (6 Pin) Top View

Table 5-1. Pin Functions

PIN			DESCRIPTION
NAME	NO.	TYPE	
D1	1	O	Open drain output of the first power MOSFETs. Typically connected to the outer terminals of the center tap transformer. Because large currents flow through these pins, their external traces should be kept short.
V _{CC}	2	P	This is the device supply pin. It should be bypassed with a 4.7 μF or greater, low ESR capacitor. When V _{CC} ≤ 2.25 V, an internal undervoltage lockout circuit trips and turns both outputs off.
D2	3	O	Open drain output of the second power MOSFETs. Typically connected to the outer terminals of the center tap transformer. Because large currents flow through these pins, their external traces should be kept short.
GND	4	P	GND is connected to the source of the power MOSFET switches via an internal sense circuit. Because large currents flow through it, the GND terminals must be connected to a low-inductance quality ground plane.
EN	5	I	The EN pin turns the device on or off. Grounding or leaving this pin floating disables all internal circuitry. If unused this pin should be tied directly to V _{CC} .
CLK	6	I	This pin is used to run the device with external clock. Internally it is pulled down to GND. If valid clock is not detected on this pin, the device shifts automatically to internal clock.

6 Specifications

6.1 Absolute Maximum Ratings

over operating free-air temperature range (unless otherwise noted)⁽¹⁾. All typical values are at $T_A = 25^\circ\text{C}$, $V_{CC} = 5\text{ V}$.

		MIN	MAX	UNIT
Supply voltage ⁽²⁾	V_{CC}	-0.5	6	V
Voltage	EN, CLK	-0.5	$V_{CC} + 0.5$ ⁽³⁾	V
Output switch voltage	D1, D2		16	V
Peak output switch current	$I_{(D1)PK}$, $I_{(D2)PK}$		2.4	A
Junction temperature, T_J		-40	150	$^\circ\text{C}$
Storage temperature range, T_{stg}		-65	150	$^\circ\text{C}$

- Stresses beyond those listed under Absolute Maximum Ratings cause permanent damage to the device. These are stress ratings only and functional operation of the device at these or any other conditions beyond those indicated under [Section 6.3](#) is not implied. Exposure to absolute-maximum-rated conditions for extended periods affects device reliability.
- All voltage values except differential I/O bus voltages are with respect to the local ground terminal (GND) and are peak voltage values.
- Maximum voltage must not exceed 6V. A strongly driven EN or CLK input signal can weakly power the floating V_{CC} via an internal protection diode and cause undetermined output.

6.2 ESD Ratings

			VALUE	UNIT
$V_{(ESD)}$	Electrostatic discharge	Human-body model (HBM), per AEC Q100-002 ⁽¹⁾ HBM ESD Classification Level 3A	± 6000	V
		Charged-device model (CDM), per AEC Q100-011 CDM ESD Classification Level C6	± 1500	

- AEC Q100-002 indicates that HBM stressing shall be in accordance with the ANSI/ESDA/JEDEC JS-001 specification.

6.3 Recommended Operating Conditions

		MIN	TYP	MAX	UNIT
V_{CC}	Supply voltage	2.25		5.5	V
I_{D1} , I_{D2}	Output switch current - Primary side	$2.25\text{ V} \leq V_{CC} \leq 2.8\text{ V}$		0.75	A
		$2.8\text{ V} < V_{CC} \leq 5.5\text{ V}$		1	
T_A	Ambient temperature	-40		125	$^\circ\text{C}$

6.4 Thermal Information

THERMAL METRIC ⁽¹⁾		SN6505x-Q1	UNIT
		DBV (SOT-23)	
		6 PINS	
$R_{\theta JA}$	Junction-to-ambient thermal resistance	137.7	$^\circ\text{C}/\text{W}$
$R_{\theta JC(top)}$	Junction-to-case (top) thermal resistance	57.7	$^\circ\text{C}/\text{W}$
$R_{\theta JB}$	Junction-to-board thermal resistance	46.0	$^\circ\text{C}/\text{W}$
Ψ_{JT}	Junction-to-top characterization parameter	13.4	$^\circ\text{C}/\text{W}$
Ψ_{JB}	Junction-to-board characterization parameter	44.9	$^\circ\text{C}/\text{W}$
$R_{\theta JC(bottom)}$	Junction-to-case(bottom) thermal resistance	N/A	$^\circ\text{C}/\text{W}$

- For more information about traditional and new thermal metrics, see the [Semiconductor and IC Package Thermal Metrics application report](#).

6.5 Electrical Characteristics

over full-range of recommended operating conditions, unless otherwise noted. All typical values are at $T_A = 25^\circ\text{C}$, $V_{CC} = 5\text{ V}$.

PARAMETER		TEST CONDITIONS	MIN	TYP	MAX	UNIT
VOLTAGE SUPPLY						
I_{VCC}	Supply Current ($2.8\text{ V} \leq V_{CC} \leq 5.5\text{ V}$) (SN6505A-Q1)	$R_L = 50\ \Omega$		1	1.4	mA
	Supply Current ($2.8\text{ V} \leq V_{CC} \leq 5.5\text{ V}$) (SN6505B-Q1 and SN6505D-Q1)	$R_L = 50\ \Omega$		1.56	2.3	mA
I_{IH}	Leakage Current on EN and CLK pin	EN / CLK = V_{CC}		10	20	μA
I_{DIS}	V_{CC} current for EN = 0			0.1		μA
$I_{LKG(D1)}$ $I_{LKG(D2)}$	Leakage Current on D1, D2 for EN=0	Voltage of D1, D2 = V_{CC}		0.1		μA
$V_{CC+ (UVLO)}$	Positive-going UVLO threshold				2.25	V
$V_{CC- (UVLO)}$	Negative-going UVLO threshold		1.7			V
$V_{HYS (UVLO1)}$	UVLO threshold hysteresis			0.3		V
$V_{IN(ON)}$	EN, CLK pin logic high threshold				0.7	V_{CC}
$V_{IN(OFF)}$	EN, CLK pin logic low threshold		0.3			V_{CC}
$V_{IN(HYS)}$	EN, CLK pin threshold hysteresis			0.2		V_{CC}
CLK						
F_{SW}	D1, D2 average switching Frequency (SN6505A-Q1)	$R_L = 50\ \Omega$ to V_{CC} ; Refer to Figure 7-3	138	160	203	KHz
	D1, D2 average switching Frequency (SN6505B-Q1 and SN6505D-Q1)	$R_L = 50\ \Omega$ to V_{CC} ; Refer to Figure 7-3 .	363	424	517	KHz
$F_{(EXT)}$	External clock frequency on CLK pin (SN6505A-Q1)		100		600	KHz
	External clock frequency on CLK pin (SN6505B-Q1 and SN6505D-Q1)		100		1600	KHz
OUTPUT STAGE						
DMM	Average ON time mismatch between D1 and D2	$R_L = 50\ \Omega$		0%		
$R_{(ON)}$	Output switch on resistance	$V_{CC} = 4.5\text{ V}$, I_{D1} , $I_{D2} = 1\text{ A}$		0.16	0.25	Ω
		$V_{CC} = 2.8\text{ V}$, I_{D1} , $I_{D2} = 1\text{ A}$		0.19	0.31	Ω
		$V_{CC} = 2.25\text{ V}$, I_{D1} , $I_{D2} = 0.5\text{ A}$		0.21	0.45	Ω
$V_{(SLEW)}$	Voltage slew rates on D1 and D2 for SN6505A-Q1	$R_L = 50\ \Omega$ to V_{CC} ; Refer to Figure 7-3		48		V/ μs
$I_{(SLEW)}$	Current slew rates at D1 and D2 for SN6505A-Q1	$R_L = 5\ \Omega$ through transformer; Refer to Figure 7-4		11		A/ μs
$V_{(SLEWHF)}$	Voltage slew rates on D1 and D2 for SN6505B-Q1 and SN6505D-Q1	$R_L = 50\ \Omega$ to V_{CC} ; Refer to Figure 7-3		152		V/ μs
$I_{(SLEWHF)}$	Current slew rates at D1 and D2 for SN6505B-Q1 and SN6505D-Q1	$R_L = 5\ \Omega$ through transformer; Refer to Figure 7-4		41		A/ μs
I_{LIM}	Current clamp limit ($2.8\text{ V} < V_{CC} \leq 5.5\text{ V}$)		1.42	1.75	2.15	A
	Current clamp limit ($2.25\text{ V} \leq V_{CC} \leq 2.8\text{ V}$)		0.65		1.85	A
THERMAL SHUT DOWN						
T_{SD+}	T_{SD} turn on temperature		154	168	181	$^\circ\text{C}$
T_{SD-}	T_{SD} turn off temperature		135	150	166	$^\circ\text{C}$
T_{SD-}	T_{SD} hysteresis		13	17		$^\circ\text{C}$

6.6 Timing Requirements

			MIN	NOM	MAX	UNIT
CLK						
$t_{CLKTIMER}$	Duration after which device switches to internal clock in case of invalid external clock		10		25	μs
OUTPUT STAGE						
t_{BBM}	Break-before-make time(SN6505A-Q1)	Measured as voltage with $R_L = 50 \Omega$ to V_{CC} , Refer to Figure 7-3		115		ns
	Break-before-make time (SN6505B-Q1 and SN6505D-Q1)	Measured as voltage with $R_L = 50 \Omega$ to V_{CC} , Refer to Figure 7-3		90		ns
SOFT-START ENABLED (SN6505A-Q1 AND SN6505B-Q1)						
t_{SS}	Soft-start time (SN6505A-Q1)	10% to 90% transition time on V_{OUT} With transformer $C_{LOAD} = 40 \mu F$ $R_L = 5 \Omega$	1	2.2	8	ms
	Soft-start time (SN6505B-Q1)	10% to 90% transition time on V_{OUT} With transformer $C_{LOAD} = 40 \mu F$ $R_L = 5 \Omega$	1	4.25	8	ms
$t_{SSdelay}$	Soft-start time delay	From power up to 90% transition time on V_{OUT} With transformer $C_{LOAD} = 40 \mu F$ $R_L = 5 \Omega$	3.5	8.5	18	ms
SOFT-START DISABLED (SN6505D-Q1)						
t_{PWRUP}	Power up time	From EN=1 to full drive-current available at D1 and D2; $2.25 V \leq V_{CC} < 3 V$		75	160	μs
		From EN=1 to full drive-current available at D1 and D2; $3 V \leq V_{CC} \leq 5.5 V$		60	100	μs
t_{PWRDN}	Power down time	From EN=0 to output MOSFETs off (no current on D1 and D2)		1	5	μs

6.7 Typical Characteristics, SN6505A-Q1

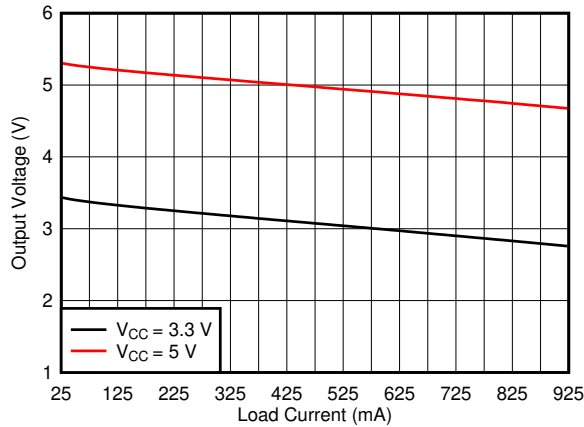

SN6505A-Q1 + Würth 750315240

Figure 6-1. Output Voltage vs Load Current

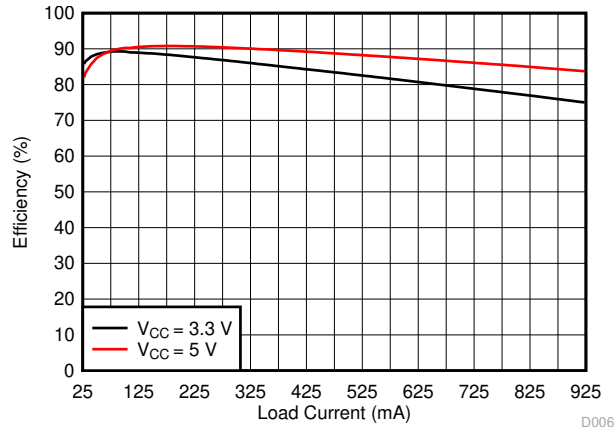

SN6505A-Q1 + Würth 750315240

Figure 6-2. Efficiency vs Load Current

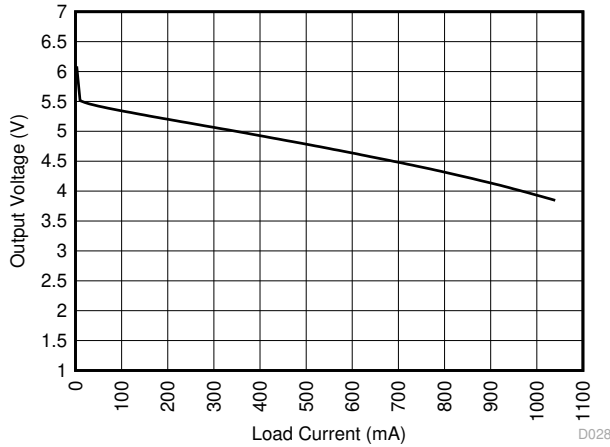

SN6505A-Q1 + Würth 750316031 $V_{CC} = 3.3\text{ V}$

Figure 6-3. Output Voltage vs Load Current



SN6505A-Q1 + Würth 750316031 $V_{CC} = 3.3\text{ V}$

Figure 6-4. Efficiency vs Load Current

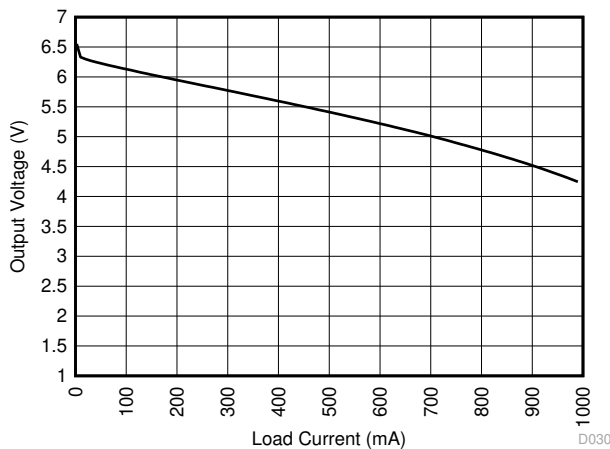

SN6505A-Q1 + Würth 750316032 $V_{CC} = 3.3\text{ V}$

Figure 6-5. Output Voltage vs Load Current

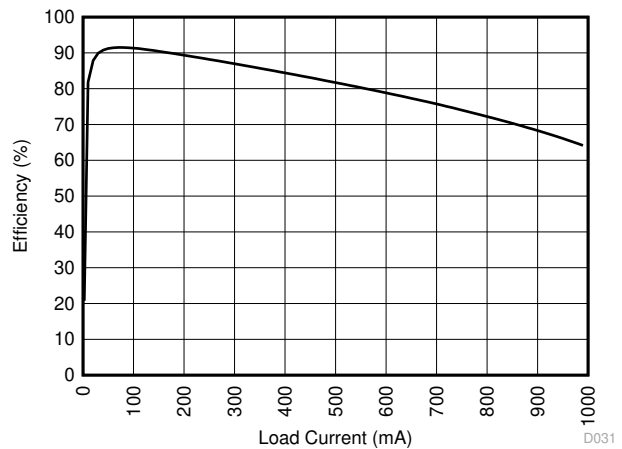

SN6505A-Q1 + Würth 750316032 $V_{CC} = 3.3\text{ V}$

Figure 6-6. Efficiency vs Load Current

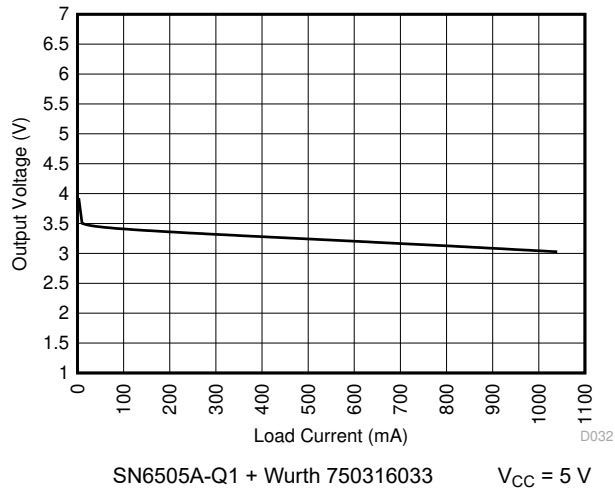

Figure 6-7. Output Voltage vs Load Current

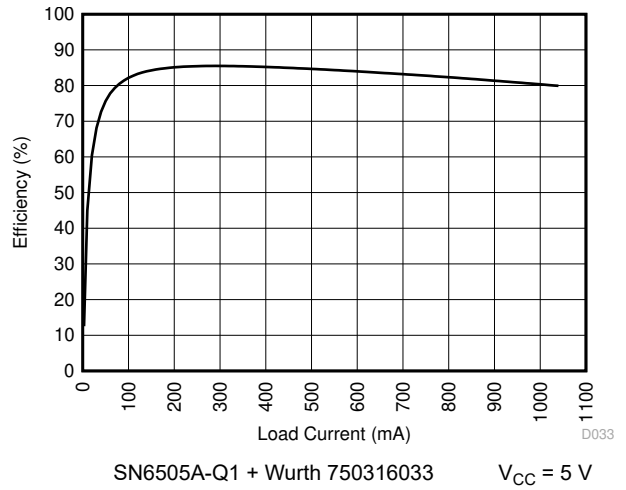

Figure 6-8. Efficiency vs Load Current

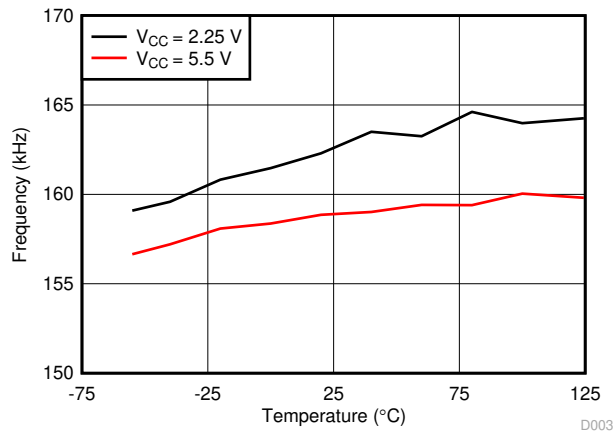

Figure 6-9. Frequency vs Free-Air Temperature

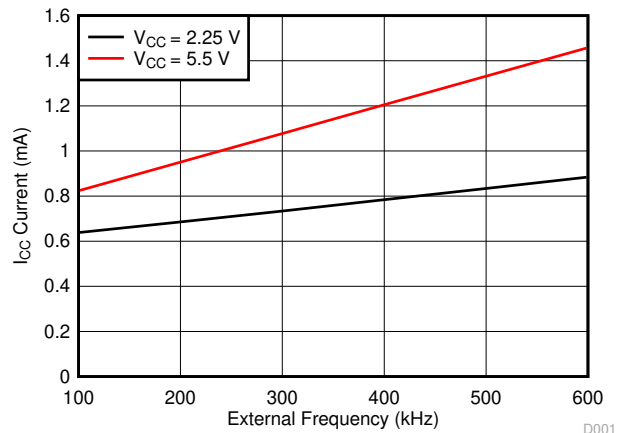

Figure 6-10. Current vs External Frequency

6.8 Typical Characteristics, SN6505B-Q1 or SN6505D-Q1

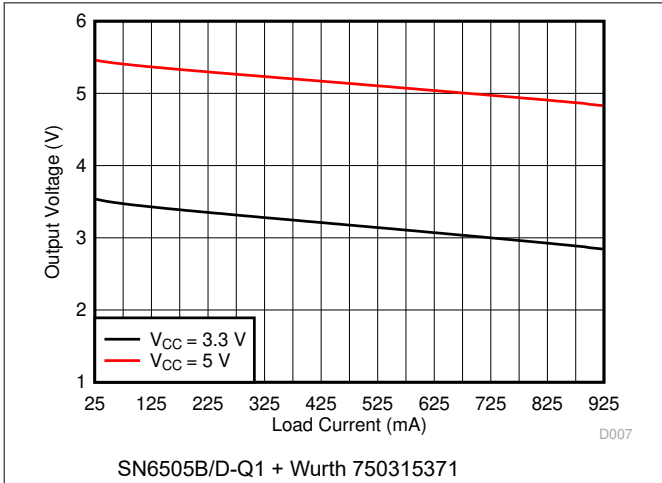

Figure 6-11. Output Voltage vs Load Current

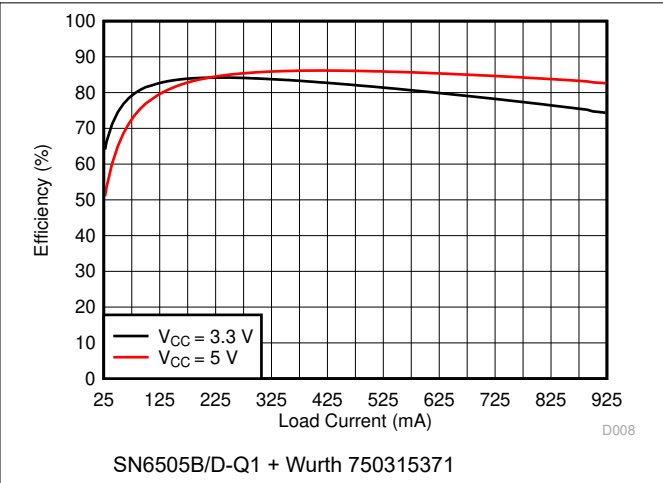

Figure 6-12. Efficiency vs Load Current

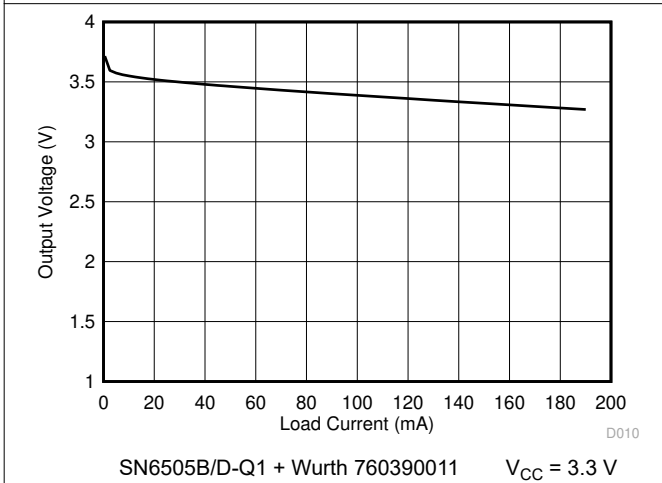

Figure 6-13. Output Voltage vs Load Current

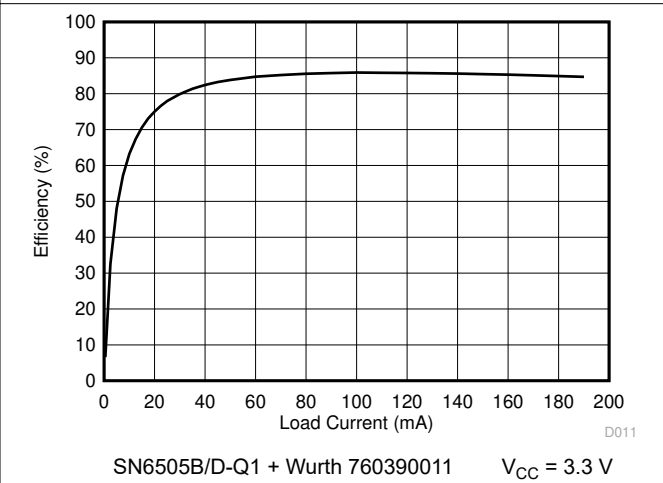

Figure 6-14. Efficiency vs Load Current

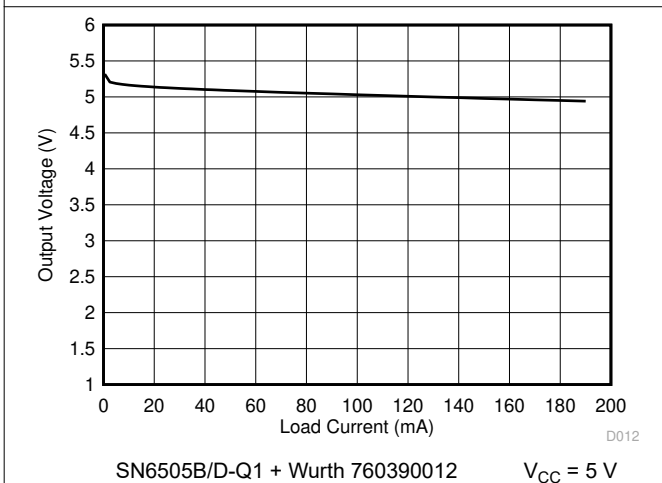

Figure 6-15. Output Voltage vs Load Current

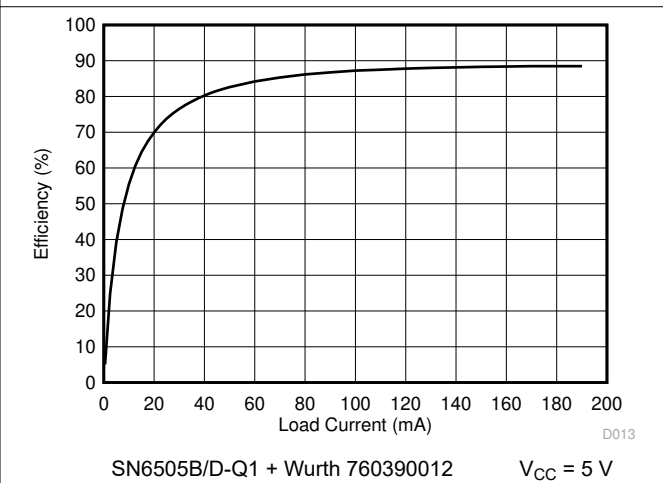

Figure 6-16. Efficiency vs Load Current

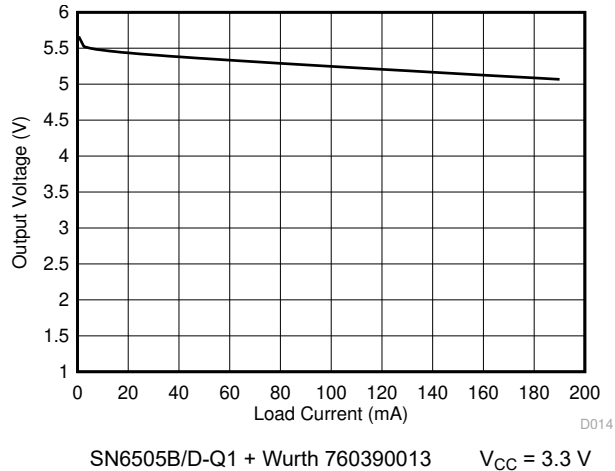

Figure 6-17. Output Voltage vs Load Current

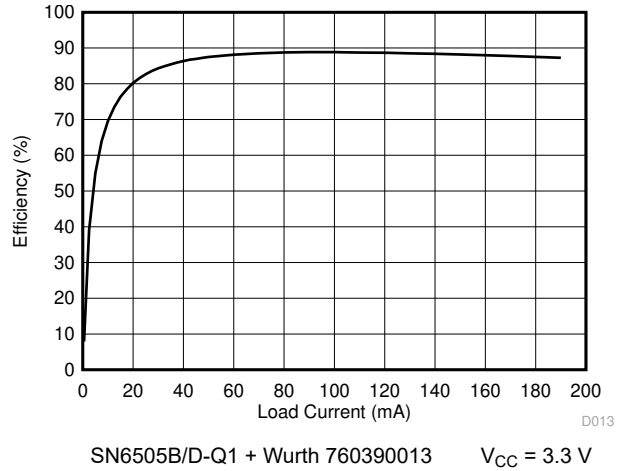

Figure 6-18. Efficiency vs Load Current

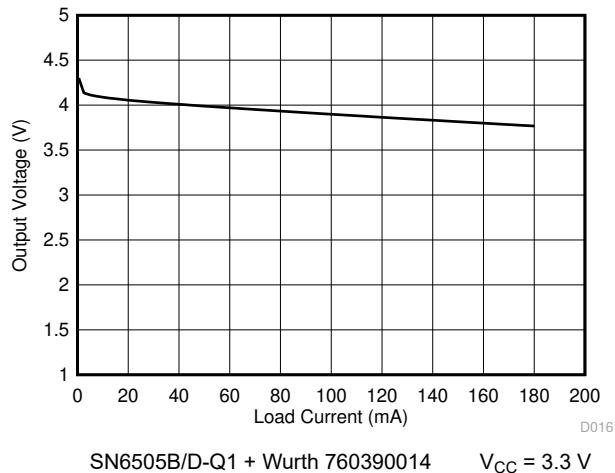

Figure 6-19. Output Voltage vs Load Current

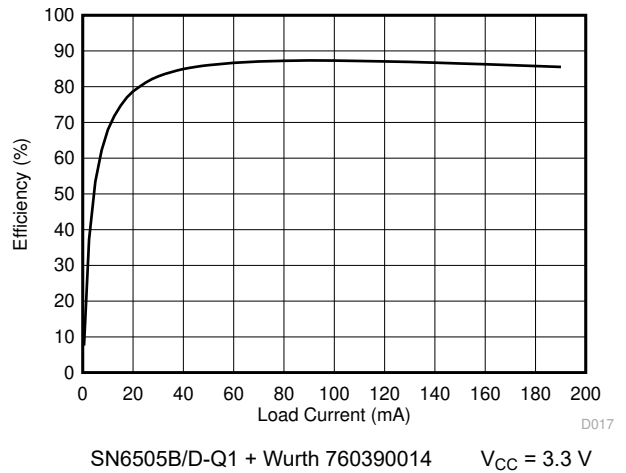

Figure 6-20. Efficiency vs Load Current

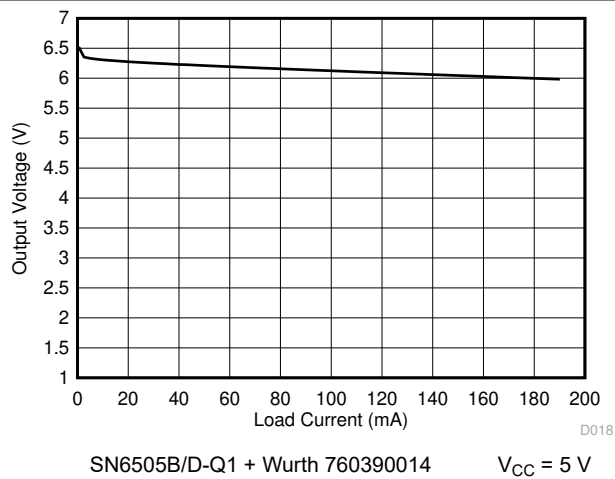

Figure 6-21. Output Voltage vs Load Current

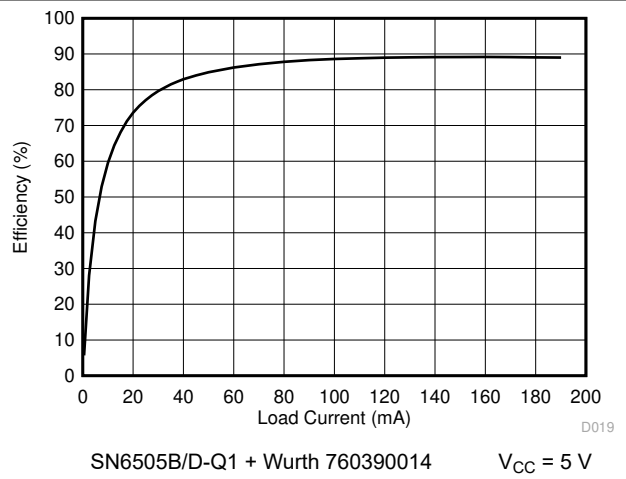

Figure 6-22. Efficiency vs Load Current

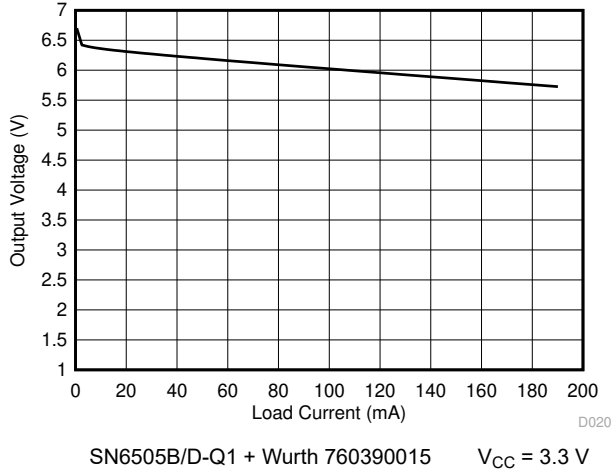

Figure 6-23. Output Voltage vs Load Current

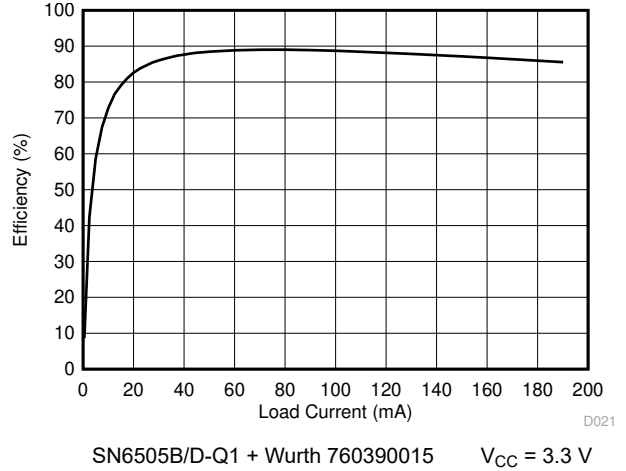

Figure 6-24. Efficiency vs Load Current

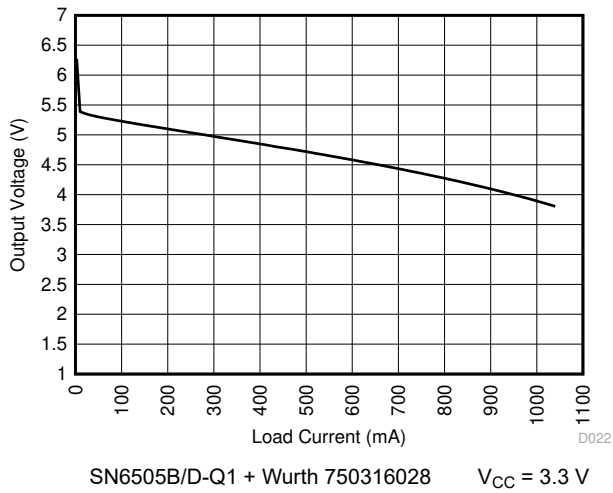

Figure 6-25. Output Voltage vs Load Current

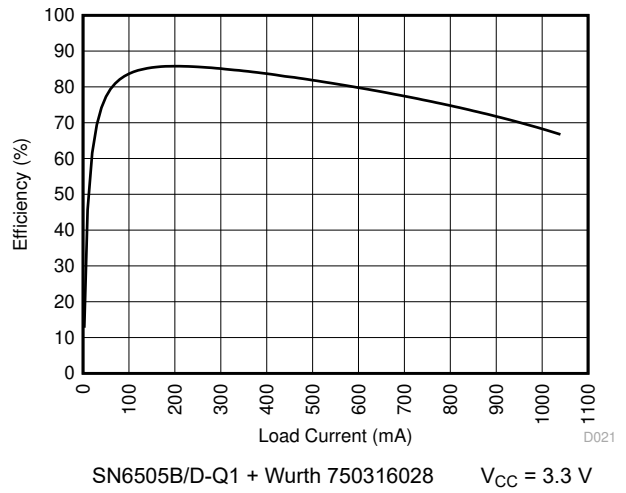

Figure 6-26. Efficiency vs Load Current

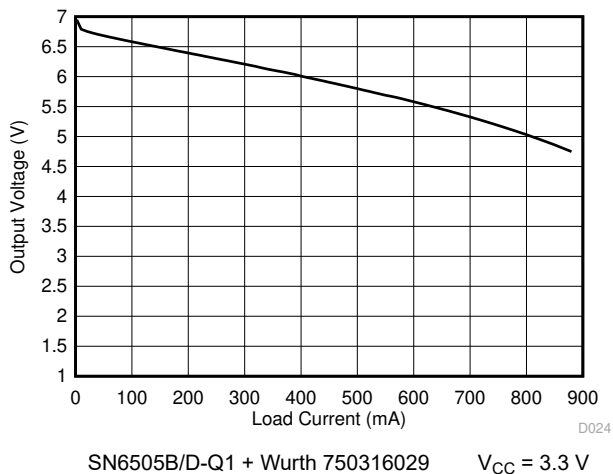

Figure 6-27. Output Voltage vs Load Current

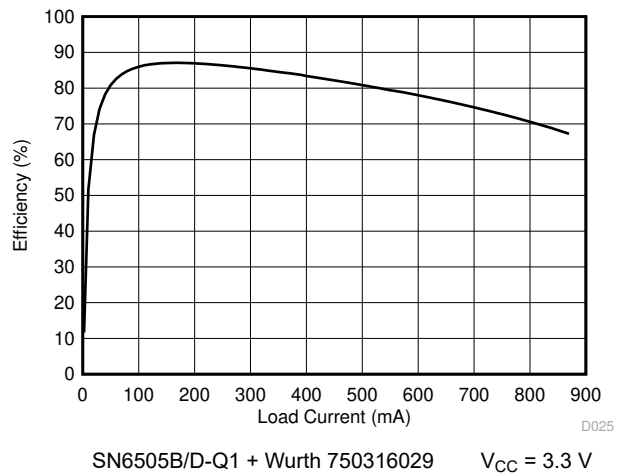
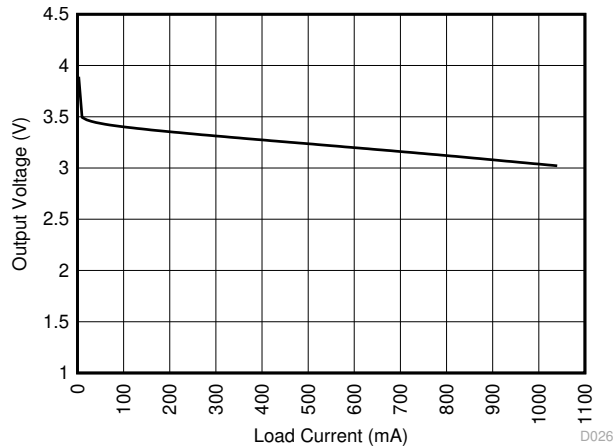
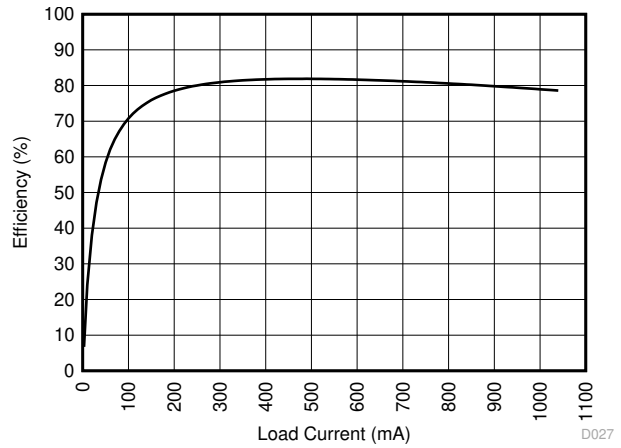

Figure 6-28. Efficiency vs Load Current



SN6505B/D-Q1 + Würth 7503160030 $V_{CC} = 5\text{ V}$ D026

Figure 6-29. Output Voltage vs Load Current



SN6505B/D-Q1 + Würth 7503160030 $V_{CC} = 5\text{ V}$ D027

Figure 6-30. Efficiency vs Load Current

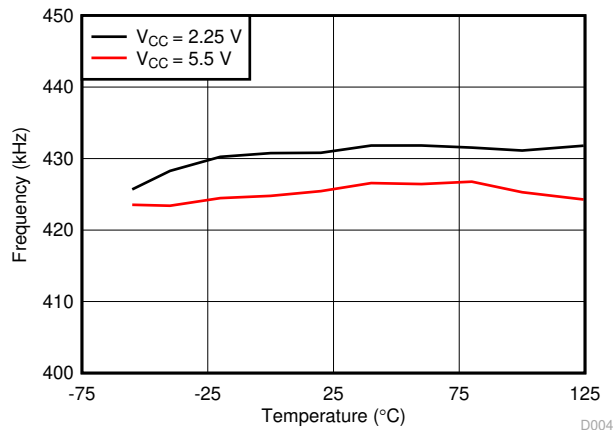

Figure 6-31. Frequency vs Free-Air Temperature D004

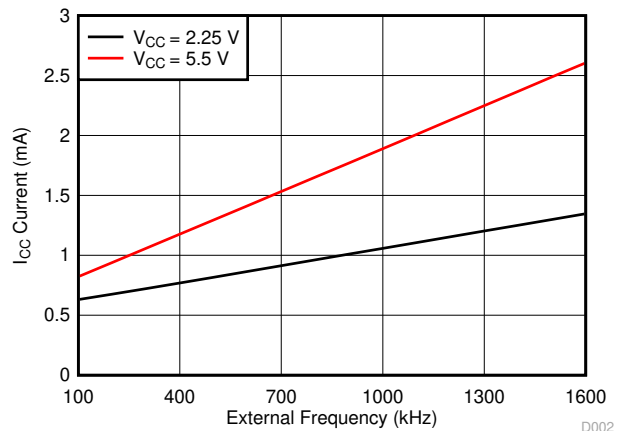

Figure 6-32. Current vs External Frequency D002

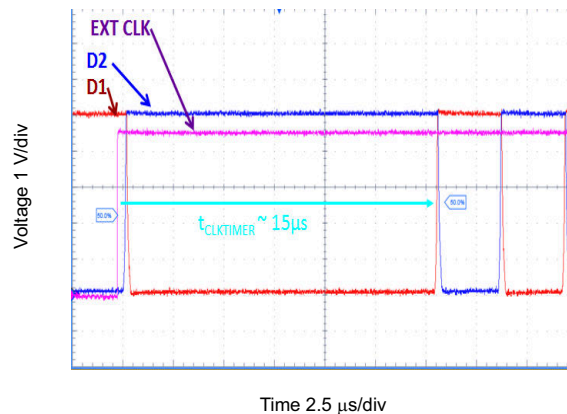

Figure 6-33. Scope Capture of SN6505 Switching from External to Internal Clock

7 Parameter Measurement Information

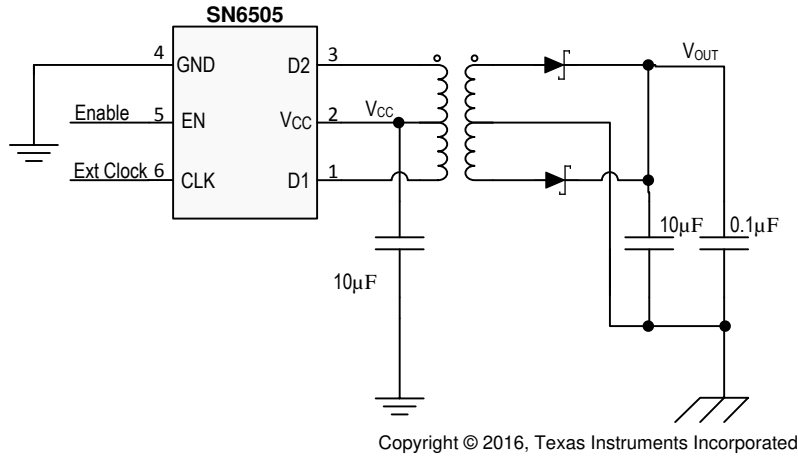

Figure 7-1. Measurement Circuit for Unregulated Output (TP1)

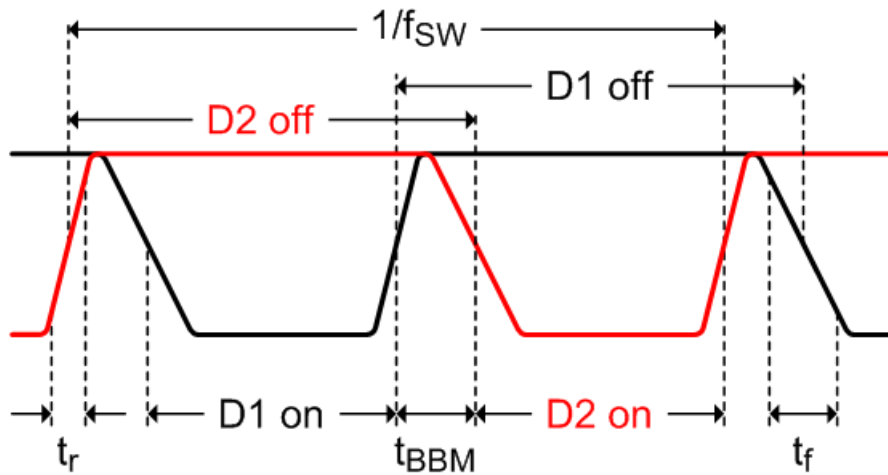

Figure 7-2. Timing Diagram

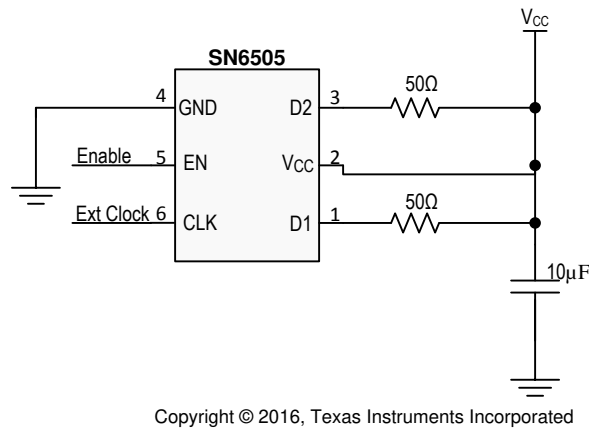
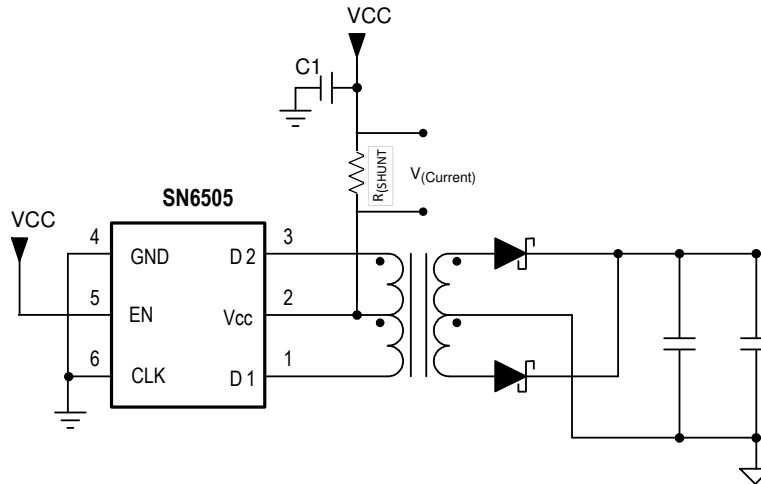

Figure 7-3. Test Circuit for F_{sw} , $V_{(slew)}$, t_{BBM}



Copyright © 2016, Texas Instruments Incorporated

Figure 7-4. $I_{(slew)}$ Test Setup

8 Detailed Description

8.1 Overview

The SN6505x-Q1 is a transformer driver designed for low-cost, small form-factor, isolated DC/DC converters utilizing the push-pull topology. The device includes an oscillator that feeds a gate-drive circuit. The gate-drive, comprising a frequency divider and a break-before-make (BBM) logic, provides two complementary output signals which alternately turn the two output transistors on and off.

The output frequency of the oscillator is divided down by two. A subsequent break-before-make logic inserts a dead-time between the high-pulses of the two signals. Before either one of the gates can assume logic high, the BBM logic ensures a short time period during which both signals are low and both transistors are high-impedance. This short period, is required to avoid shorting out both ends of the primary. The resulting output signals, present the gate-drive signals for the output transistors.

8.2 Functional Block Diagram

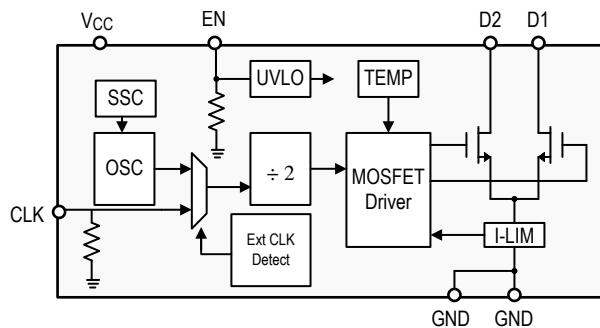

8.3 Feature Description

8.3.1 Push-Pull Converter

Push-pull converters require transformers with center-taps to transfer power from the primary to the secondary (see Figure 8-1).

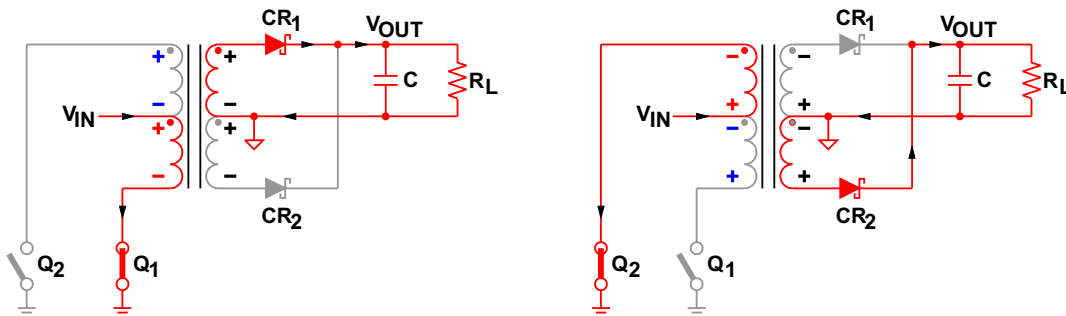

Figure 8-1. Switching Cycles of a Push-Pull Converter

When Q_1 conducts, V_{IN} drives a current through the lower half of the primary to ground, thus creating a negative voltage potential at the lower primary end with regards to the V_{IN} potential at the center-tap.

At the same time the voltage across the upper half of the primary is such that the upper primary end is positive with regards to the center-tap in order to maintain the previously established current flow through Q_2 , which now has turned high-impedance. The two voltage sources, each of which equaling V_{IN} , appear in series and cause a voltage potential at the open end of the primary of $2 \times V_{IN}$ with regards to ground.

Per dot convention the same voltage polarities that occur at the primary also occur at the secondary. The positive potential of the upper secondary end therefore forward biases diode CR_1 . The secondary current starting from the upper secondary end flows through CR_1 , charges capacitor C , and returns through the load impedance R_L back to the center-tap.

When Q_2 conducts, Q_1 goes high-impedance and the voltage polarities at the primary and secondary reverse. Now the lower end of the primary presents the open end with a $2 \times V_{IN}$ potential against ground. In this case CR_2 is forward biased while CR_1 is reverse biased and current flows from the lower secondary end through CR_2 , charging the capacitor and returning through the load to the center-tap.

8.3.2 Core Magnetization

Figure 8-2 shows the ideal magnetizing curve for a push-pull converter with B as the magnetic flux density and H as the magnetic field strength. When Q_1 conducts the magnetic flux is pushed from A to A' , and when Q_2 conducts the flux is pulled back from A' to A . The difference in flux and thus in flux density is proportional to the product of the primary voltage, V_P , and the time, t_{ON} , it is applied to the primary: $B \approx V_P \times t_{ON}$.

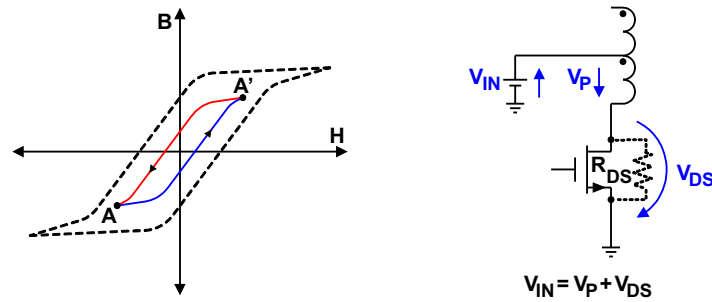

Figure 8-2. Core Magnetization and Self-Regulation Through Positive Temperature Coefficient of $R_{DS(on)}$

This volt-seconds (V-t) product is important as it determines the core magnetization during each switching cycle. If the V-t products of both phases are not identical, an imbalance in flux density swing results with an offset from the origin of the B-H curve. If balance is not restored, the offset increases with each following cycle and the transformer slowly creeps toward the saturation region.

8.4 Device Functional Modes

The functional modes of the device are divided into start-up, operating, and off-mode.

8.4.1 Start-Up Mode

When the supply voltage at V_{CC} ramps up to 2.25 V, the internal oscillator starts operating. The output stage begins switching but the amplitude of the drain signals at D1 and D2 has not reached its full maximum yet.

8.4.1.1 Soft-Start

SN6505A-Q1 and SN6505B-Q1 devices support soft-start feature. Upon power up or when EN pin transitions from Low to High, the gate drive of the output power-MOSFET is gradually increased over a period of time from 0 V to V_{CC} . Soft-start prevents high inrush current from V_{CC} while charging large secondary side decoupling capacitors, and also prevents overshoot in secondary voltage during power-up. For applications that need quick power-up, the SN6505D-Q1, that has soft-start disabled, can be used.

8.4.2 Operating Mode

When the device supply has reached its nominal value $\pm 10\%$ the oscillator is fully operating. However variations over supply voltage and operating temperature can vary the switching frequencies at D1 and D2.

8.4.3 Shutdown-Mode

The device has a dedicated enable pin to put the device in very low power mode to save power when not in use. Enable pin has an internal pull down resistor which keeps device disabled when not driven. When disabled or when V_{CC} is < 1.7 V, both drain outputs, D1 and D2, are tri-stated.

8.4.4 Spread Spectrum Clocking

Radiated emissions is an important concern in high current switching power supplies. SN6505 addresses this by modulating its internal clock in such a way that the emitting energy is spread over multiple frequency bins. This Spread Spectrum clocking feature greatly improves the emissions performance of the entire power supply block and hence relieves the system designer from one major concern in isolated power supply design.

8.4.5 External Clock Mode

The SN6505x-Q1 has a CLK pin which can be used to synchronize the device with system clock and in turn with other SN6505x-Q1 devices so that the system can control the exact switching frequency of the device. The Rising edge of the CLK is used to divide a clock by two and used to drive the gates. [Figure 9-2](#) shows the timing diagram for the same. The device also has external clock fail safe feature which automatically switches the device to the internal clock if a valid input clock is not present for long ($t_{CLKTIMER}$). The in-built emissions reduction scheme of Spread Spectrum clocking is disabled when external clock is present.

9 Application and Implementation

Note

Information in the following applications sections is not part of the TI component specification, and TI does not warrant its accuracy or completeness. TI's customers are responsible for determining suitability of components for their purposes. Customers should validate and test their design implementation to confirm system functionality.

9.1 Application Information

The SN6505x-Q1 is a transformer driver designed for low-cost, small form-factor, isolated DC/DC converters using the push-pull topology. The device includes an oscillator that feeds a gate-drive circuit. The gate-drive, comprising a frequency divider and a break-before-make (BBM) logic, provides two complementary output signals which alternately turn the two output transistors on and off.

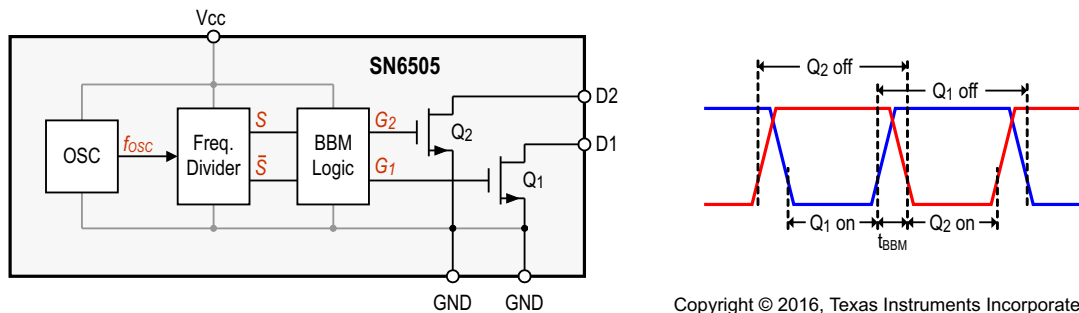

Copyright © 2016, Texas Instruments Incorporated

Figure 9-1. Block Diagram and Output Timing With Break-Before-Make Action

The output frequency of the oscillator is divided down by an asynchronous divider that provides two complementary output signals, S and \bar{S} , with a 50% duty cycle. A subsequent break-before-make logic inserts a dead-time between the high-pulses of the two signals. The resulting output signals, G₁ and G₂, present the gate-drive signals for the output transistors Q₁ and Q₂. As shown in Figure 9-2, before either one of the gates can assume logic high, there must be a short time period during which both signals are low and both transistors are high-impedance. This short period, known as break-before-make time, is required to avoid shorting out both ends of the primary.

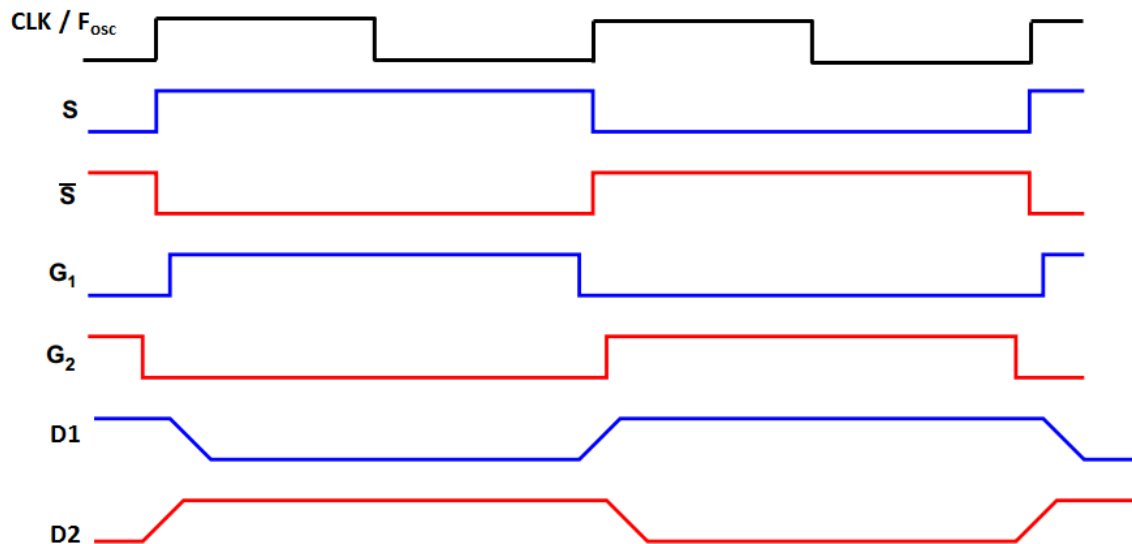
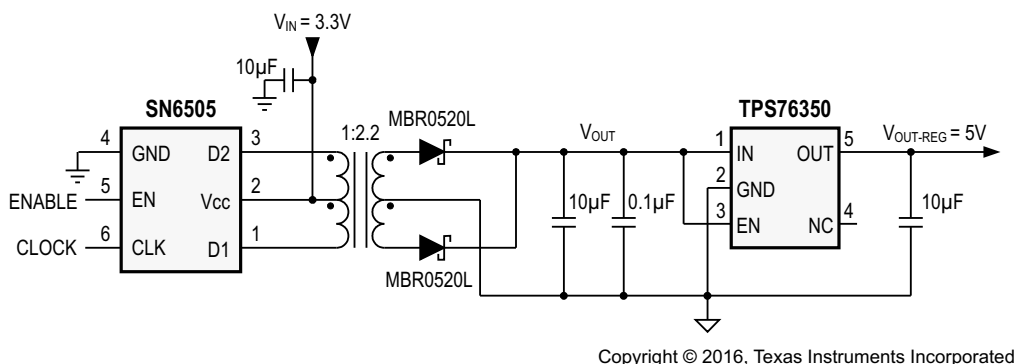

Figure 9-2. Detailed Output Signal Waveforms

9.2 Typical Application



Copyright © 2016, Texas Instruments Incorporated

Figure 9-3. Typical Application Schematic

9.2.1 Design Requirements

For this design example, use the parameters listed in [Table 9-1](#) as design parameters.

Table 9-1. Design Parameters

DESIGN PARAMETER	EXAMPLE VALUE
Input voltage range	3.3 V ± 3%
Output voltage	5 V
Maximum load current	100 mA

9.2.2 Detailed Design Procedure

The following recommendations on components selection focus on the design of an efficient push-pull converter with high current drive capability. Contrary to popular belief, the output voltage of the unregulated converter output drops significantly over a wide range in load current. The characteristic curve in [Figure 6-1](#) and [Figure 6-11](#) for example, shows that the difference between V_{OUT} at minimum load and V_{OUT} at maximum load exceeds a transceiver's supply range. Therefore, in order to provide a stable, load independent supply while maintaining maximum possible efficiency the implementation of a low dropout regulator (LDO) is strongly advised.

The final converter circuit is shown in [Figure 9-8](#). The measured V_{OUT} and efficiency characteristics for the regulated and unregulated outputs are shown in [Figure 6-2](#) and [Figure 6-12](#).

9.2.2.1 Drive Capability

The transformer driver is designed for low-power push-pull converters with input and output voltages in the range of 2.25 V to 5.5 V. While converter designs with higher output voltages are possible, care must be taken that higher turns ratios don't lead to primary currents that exceed the specified current limits of the device.

9.2.2.2 LDO Selection

The minimum requirements for a suitable low dropout regulator are:

- Its current drive capability should slightly exceed the specified load current of the application to prevent the LDO from dropping out of regulation. Therefore, for a load current of 600 mA, choose a 600 mA to 750 mA LDO. While regulators with higher drive capabilities are acceptable, they also usually possess higher dropout voltages that will reduce overall converter efficiency.
- The internal dropout voltage, V_{DO} , at the specified load current should be as low as possible to maintain efficiency. For a low-cost 750 mA LDO, a V_{DO} of 600 mV at 750 mA is common. Be aware; however, that this lower value is usually specified at room temperature and can increase by a factor of 2 over temperature, which in turn will raise the required minimum input voltage.
- The required minimum input voltage preventing the regulator from dropping out of line regulation is given with:

$$V_{I-\min} = V_{DO-\max} + V_{O-\max} \quad (1)$$

This means in order to determine V_I for worst-case condition, the user must take the maximum values for V_{DO} and V_O specified in the LDO data sheet for rated output current (that is, 600 mA) and add them together. Also specify that the output voltage of the push-pull rectifier at the specified load current is equal or higher than $V_{I-\min}$. If it is not, the LDO will lose line-regulation and any variations at the input passes straight through to the output. Hence, below $V_{I-\min}$ the output voltage follows the input and the regulator behaves like a simple conductor.

- The maximum regulator input voltage must be higher than the rectifier output under no-load. Under this condition there is no secondary current reflected back to the primary, thus making the voltage drop across R_{DS-on} negligible and allowing the entire converter input voltage to drop across the primary. At this point, the secondary reaches its maximum voltage of

$$V_{S-\max} = V_{IN-\max} \times n \quad (2)$$

with $V_{IN-\max}$ as the maximum converter input voltage and n as the transformer turns ratio. Thus to prevent the LDO from damage the maximum regulator input voltage must be higher than $V_{S-\max}$. Table 9-2 lists the maximum secondary voltages for various turns ratios commonly applied in push-pull converters.

Table 9-2. Required Maximum LDO Input Voltages for Various Push-Pull Configurations

PUSH-PULL CONVERTER				LDO
CONFIGURATION	$V_{IN-\max}$ [V]	URNS-RATIO	$V_{S-\max}$ [V]	$V_{I-\max}$ [V]
3.3 V_{IN} to 3.3 V_{OUT}	3.6	1.5 ± 3%	5.6	6 to 10
3.3 V_{IN} to 5 V_{OUT}	3.6	2.2 ± 3%	8.2	10
5 V_{IN} to 5 V_{OUT}	5.5	1.5 ± 3%	8.5	10

9.2.2.3 Diode Selection

A rectifier diode should always possess low-forward voltage to provide as much voltage to the converter output as possible. When used in high-frequency switching applications, such as the SN6505x-Q1 however, the diode must also possess a short recovery time. Schottky diodes meet both requirements and are therefore strongly recommended in push-pull converter designs. A good choice for low-volt applications and ambient temperatures of up to 85°C is the low-cost Schottky rectifier MBR0520L with a typical forward voltage of 275 mV at 100-mA forward current. For higher output voltages such as ±10 V and above use the MBR0530 which provides a higher DC blocking voltage of 30 V.

Lab measurements have shown that at temperatures higher than 100°C the leakage currents of the above Schottky diodes increase significantly. This can cause thermal runaway leading to the collapse of the rectifier output voltage. Therefore, for ambient temperatures higher than 85°C use low-leakage Schottky diodes, such as RB168MM-40.

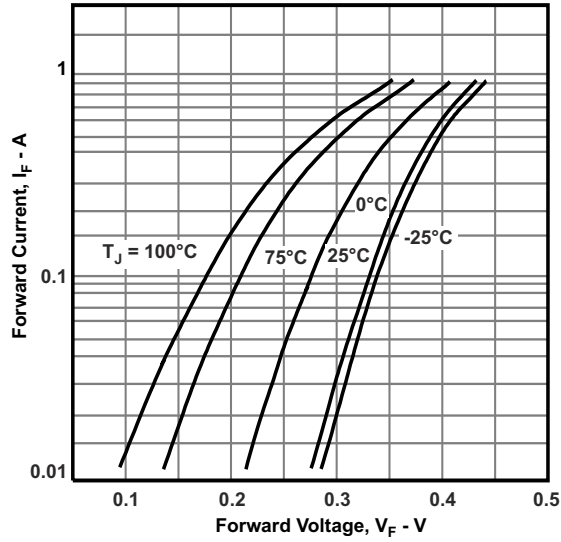

Figure 9-4. Diode Forward Characteristics for MBR0520L

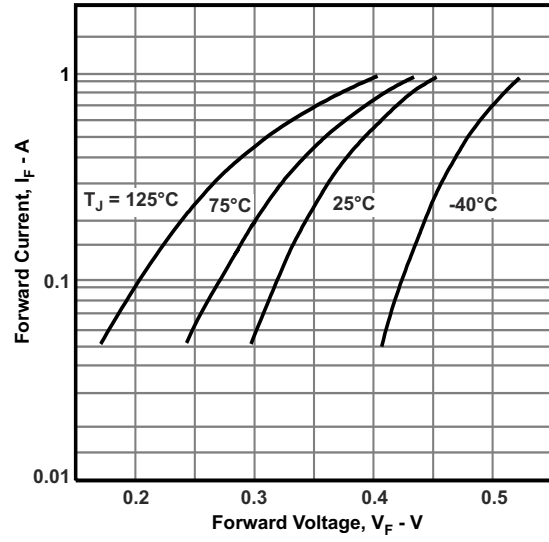

Figure 9-5. Diode Forward Characteristics MBR0530

9.2.2.4 Capacitor Selection

The capacitors in the converter circuit in [Figure 9-8](#) are multi-layer ceramic chip (MLCC) capacitors.

As with all high speed CMOS ICs, the device requires a bypass capacitor in the range of 10 nF to 100 nF.

The input bulk capacitor at the center-tap of the primary supports large currents into the primary during the fast switching transients. For minimum ripple make this capacitor 1 μF to 10 μF. In a 2-layer PCB design with a dedicated ground plane, place this capacitor close to the primary center-tap to minimize trace inductance. In a 4-layer board design with low-inductance reference planes for ground and V_{IN} , the capacitor can be placed at the supply entrance of the board. To ensure low-inductance paths use two vias in parallel for each connection to a reference plane or to the primary center-tap.

The bulk capacitor at the rectifier output smooths the output voltage. Make this capacitor 1 μF to 10 μF.

The small capacitor at the regulator input is not necessarily required. However, good analog design practice suggests, using a small value of 47 nF to 100 nF improves the regulator's transient response and noise rejection.

The LDO output capacitor buffers the regulated output for the subsequent isolator and transceiver circuitry. The choice of output capacitor depends on the LDO stability requirements specified in the data sheet. However, in most cases, a low-ESR ceramic capacitor in the range of 4.7 μF to 10 μF will satisfy these requirements.

9.2.2.5 Transformer Selection

9.2.2.5.1 V-t Product Calculation

To prevent a transformer from saturation its V-t product must be greater than the maximum V-t product applied by the device. The maximum voltage delivered by the device is the nominal converter input plus 10%. The maximum time this voltage is applied to the primary is half the period of the lowest frequency at the specified input voltage. Therefore, the transformer's minimum V-t product is determined through:

$$Vt_{\min} \geq V_{IN-\max} \times \frac{T_{\max}}{2} = \frac{V_{IN-\max}}{2 \times f_{\min}} \quad (3)$$

Taking an example of f_{\min} as 138 kHz for SN6505A-Q1 and 363 kHz for SN6505B-Q1 or SN6505D-Q1 with a 5 V supply, [Equation 3](#) yields the minimum V-t products of:

$$Vt_{\min} \geq \frac{5.5 \text{ V}}{2 \times 138 \text{ kHz}} = 20 \text{ V}\mu\text{s} \quad \text{for SN6505A-Q1, and}$$

$$Vt_{\min} \geq \frac{5.5 \text{ V}}{2 \times 363 \text{ kHz}} = 7.6 \text{ V}\mu\text{s} \quad \text{for SN6505B/D-Q1 applications.} \quad (4)$$

Common V-t values for low-power center-tapped transformers range from 22 Vμs to 150 Vμs with typical footprints of 10 mm x 12 mm. However, transformers specifically designed for PCMCIA applications provide as little as 11 Vμs and come with a significantly reduced footprint of 6 mm x 6 mm only.

While Vt-wise all of these transformers can be driven by the device, other important factors such as isolation voltage, transformer wattage, and turns ratio must be considered before making the final decision.

9.2.2.5.2 Turns Ratio Estimate

Assume the rectifier diodes and linear regulator has been selected. Also, it has been determined that the transformer chosen must have a V-t product of at least 11 Vμs. However, before searching the manufacturer web sites for a suitable transformer, the user still needs to know its minimum turns ratio that allows the push-pull converter to operate flawlessly over the specified current and temperature range. This minimum transformation ratio is expressed through the ratio of minimum secondary to minimum primary voltage multiplied by a correction factor that takes the transformer's typical efficiency of 97% into account:

$$V_{P-\min} = V_{IN-\min} - V_{DS-\max} \quad (5)$$

$V_{S-\min}$ must be large enough to allow for a maximum voltage drop, $V_{F-\max}$, across the rectifier diode and still provide sufficient input voltage for the regulator to remain in regulation. From the [Section 9.2.2.2](#) section, this minimum input voltage is known and by adding $V_{F-\max}$ gives the minimum secondary voltage with:

$$V_{S-\min} = V_{F-\max} + V_{DO-\max} + V_{O-\max} \quad (6)$$

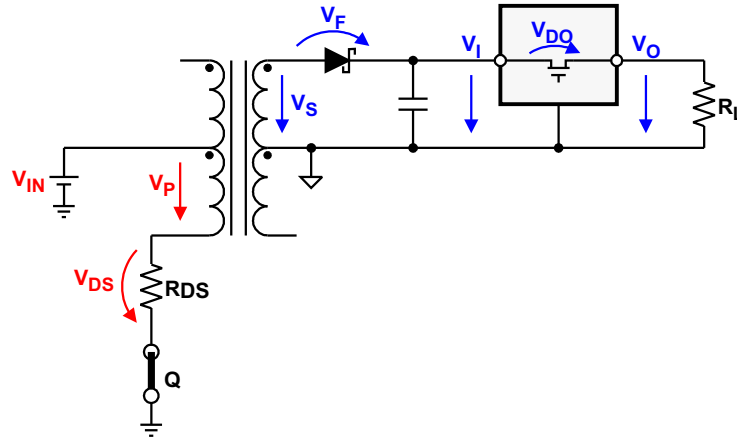

Figure 9-6. Establishing the Required Minimum Turns Ratio Through $N_{\min} = 1.031 \times V_{S-\min} / V_{P-\min}$

Then calculating the available minimum primary voltage, $V_{P-\min}$, involves subtracting the maximum possible drain-source voltage of the device, $V_{DS-\max}$, from the minimum converter input voltage $V_{IN-\min}$:

$$V_{P-\min} = V_{IN-\min} - V_{DS-\max} \quad (7)$$

$V_{DS-\max}$ however, is the product of the maximum $R_{DS(on)}$ and I_D values for a given supply specified in the data sheet:

$$V_{DS-\max} = R_{DS-\max} \times I_{D-\max} \quad (8)$$

Then inserting [Equation 8](#) into [Equation 7](#) yields:

$$V_{P-\min} = V_{IN-\min} - R_{DS-\max} \times I_{D-\max} \quad (9)$$

and inserting [Equation 9](#) and [Equation 6](#) into [Equation 5](#) provides the minimum turns ration with:

$$n_{\min} = 1.031 \times \frac{V_{F-\max} + V_{DO-\max} + V_{O-\max}}{V_{IN-\min} - R_{DS-\max} \times I_{D-\max}} \quad (10)$$

Example:

For a 3.3 V_{IN} to 5 V_{OUT} converter using the rectifier diode MBR0520L and the 5 V LDO, the data sheet values taken for a load current of 600 mA and a maximum temperature of 85°C are $V_{F-\max} = 0.2$ V, $V_{DO-\max} = 0.5$ V, and $V_{O-\max} = 5.1$ V.

Then assuming that the converter input voltage is taken from a 3.3 V controller supply with a maximum $\pm 2\%$ accuracy makes $V_{IN-\min} = 3.234$ V. Finally the maximum values for drain-source resistance and drain current at 3.3 V are taken from the data sheet with $R_{DS-\max} = 0.31$ Ω and $I_{D-\max} = 1$ A.

Inserting the values above into [Equation 10](#) yields a minimum turns ratio of:

$$\eta_{\min} = 1.031 \times \frac{0.2 \text{ V} + 0.5 \text{ V} + 5.1 \text{ V}}{3.234 \text{ V} - 0.31 \Omega \times 1 \text{ A}} = 2.05 \quad (11)$$

Most commercially available transformers for 3-to-5 V push-pull converters offer turns ratios between 2.0 and 2.3 with a common tolerance of $\pm 3\%$.

9.2.2.5.3 Recommended Transformers

Depending on the application, use the minimum configuration in [Figure 9-7](#) or standard configuration in [Figure 9-8](#).

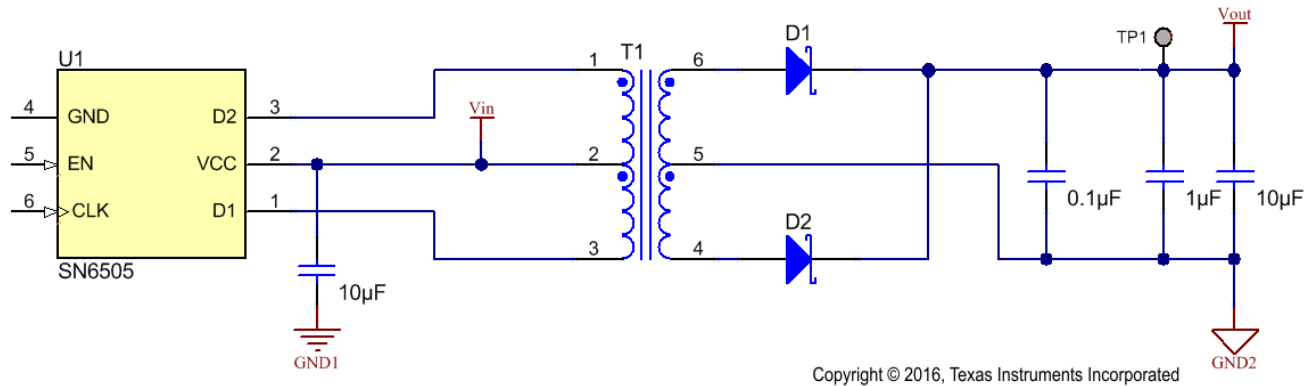

Figure 9-7. Unregulated Output for Low-Current Loads With Wide Supply Range

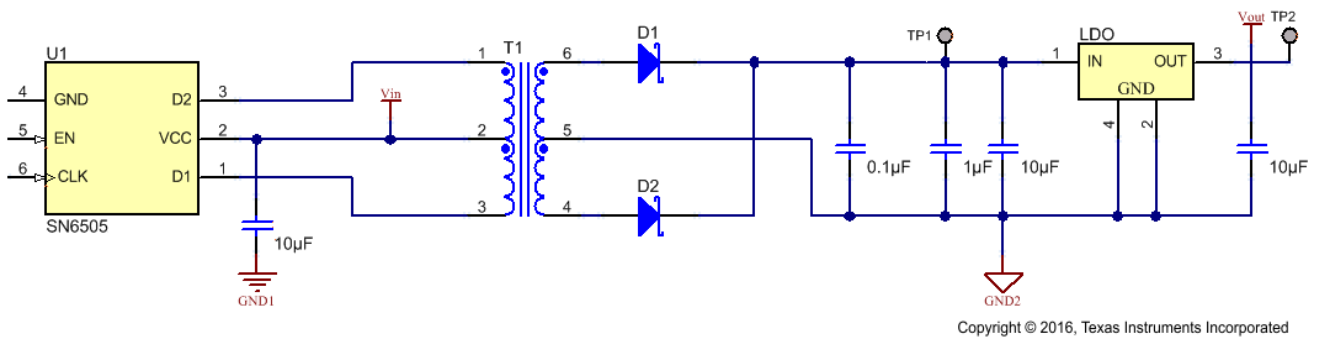

Figure 9-8. Regulated Output for Stable Supplies and High Current Loads

The Würth Electronics Midcom isolation transformers in [Table 9-3](#) are optimized designs for the device, providing high efficiency and small form factor at low-cost.

The 1:1.1 and 1:1.7 turns-ratios are designed for logic applications with wide supply rails and low load currents. These applications operate without LDO, thus achieving further cost-reduction.

Table 9-3. Recommended Isolation Transformers Optimized for the Device

TURNS RATIO	V × T (Vμs)	ISOLATION (V _{RMS})	DIMENSIONS (mm)	APPLICATION	LDO ⁽¹⁾	ORDER NO.	MANUFACTURER
1:1.1 ±2%	7	2500	6.73 x 10.05 x 4.19	3.3 V → 3.3 V, 100mA, SN6505B/D-Q1 Refer to Figure 6-13 and Figure 6-14	No	760390011	Würth Electronics / Midcom
1:1.1 ±2%	11			5 V → 5 V, 100mA, SN6505B/D-Q1 Refer to Figure 6-15 and Figure 6-16		760390012	
1:1.7 ±2%				3.3 V → 5 V, 100mA, SN6505B/D-Q1 Refer to Figure 6-17 and Figure 6-18		760390013	
1:1.3 ±2%				3.3 V → 3.3 V, 100mA, SN6505B/D-Q1 Refer to Figure 6-19 and Figure 6-20	760390014		
1:1.3 ±2%				5 V → 5 V, 100mA, SN6505B/D-Q1 Refer to Figure 6-21 and Figure 6-22	760390014		
1:2.1 ±2%				3.3 V → 5 V, 100mA, SN6505B/D-Q1 Refer to Figure 6-23 and Figure 6-24	760390015		
1.23:1 ±2%				5 V → 3.3 V, 100mA, SN6505B/D-Q1	750313710		
1:1.7 ±2%			8.9	8.3 x 12.6 x 4.1	3.3 V → 3.3 V, 1A, SN6505B/D-Q1 Refer to Figure 6-25 and Figure 6-26	No	
1:2.1 ±2%	3.3 V → 5 V, 1A, SN6505B/D-Q1 Refer to Figure 6-27 and Figure 6-28				750316029		
1.3:1 ±2%	5 V → 3.3 V, 1A, SN6505B/D-Q1 Refer to Figure 6-29 and Figure 6-30				750316030		
	3.3 V → 3.3 V, 1A, SN6505B/D-Q1 5 V → 5 V, 1A, SN6505B/D-Q1 Refer to Figure 6-11 and Figure 6-12				750315371		
1:1.1 ±2%	11		9.14 x 12.7 x 7.37	3.3 V → 3.3 V, 100mA, SN6505B/D-Q1	Yes	750313734	
1:1.1 ±2%				5 V → 5 V, 100mA, SN6505B/D-Q1		750313734	
1:1.7 ±2%				3.3 V → 5 V, 100mA, SN6505B/D-Q1		750313769	
1:1.3 ±2%		3.3 V → 3.3 V, 100mA, SN6505B/D-Q1 5 V → 5 V, 100mA, SN6505B/D-Q1		750313638			
1:2.1 ±2%		3.3 V → 5 V, 100mA, SN6505B/D-Q1		750313626			
1.3:1 ±2%		5 V → 3.3 V, 100mA, SN6505B/D-Q1		750313638			
1:1.75 ±2%		41	12.32 x 15.41 x 11.05	3.3 V → 3.3 V, 1A, SN6505A-Q1 Refer to Figure 6-3 and Figure 6-4	Yes	750316031	
1:2 ±2%				3.3 V → 5 V, 1A, SN6505A-Q1 Refer to Figure 6-5 and Figure 6-6		750316032	
1.3:1 ±2%			42	12.32 x 15.41 x 11.89	5.0 V → 3.3 V, 1A, SN6505A-Q1 Refer to Figure 6-7 and Figure 6-8	No	750316033
					3.3 V → 3.3 V, 1A, SN6505A-Q1 5 V → 5 V, 1A, SN6505A-Q1 Refer to Figure 6-1 and Figure 6-2		750315240
1:1.3 ±3%	11	5000	10.4 x 12.2 x 6.1	3.3 V → 3.3 V, 300mA, SN6505B/D-Q1 5 V → 5 V, 300mA, SN6505B/D-Q1	No	HCT-SM-1.3-8-2	Bourns
1:1.5 ±3%	34.4	2500	10 x 12.07 x 5.97	3.3 V → 3.3 V, 1A, SN6505A/B/D-Q1 5 V → 5 V, 1A, SN6505A/B/D-Q1	Yes	DA2303-AL	Coilcraft
1:2.2 ±3%	21.5	2500	10 x 12.07 x 5.97	3.3 V → 5 V, 1A, SN6505A/B/D-Q1		DA2304-AL	

(1) For configurations with LDO, a higher voltage than the required output voltage is generated, to allow for LDO drop-out. Figures show the voltage and efficiency at the LDO input.

9.2.3 Application Curves

See the [Section 6.7](#) and [Section 6.8](#) for application curves with transformers optimized for the device, providing high efficiency and small form factor at low-cost.

9.2.4 System Examples

9.2.4.1 Higher Output Voltage Designs

The device can drive push-pull converters that provide high output voltages of up to 30 V, or bipolar outputs of up to ± 15 V. Using commercially available center-tapped transformers, with their rather low turns ratios of 0.8 to 5, requires different rectifier topologies to achieve high output voltages. Figure 9-9 to Figure 9-11 show some of these topologies together with their respective open-circuit output voltages.

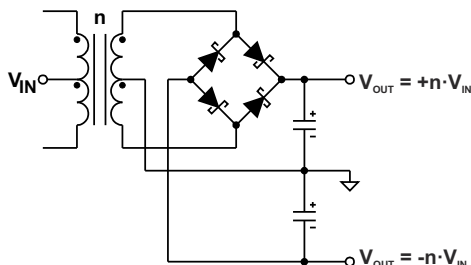

Figure 9-9. Bridge Rectifier With Center-Tapped Secondary Enables Bipolar Outputs

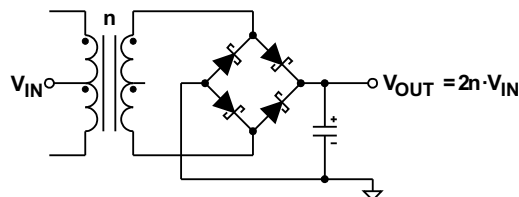

Figure 9-10. Bridge Rectifier Without Center-Tapped Secondary Performs Voltage Doubling

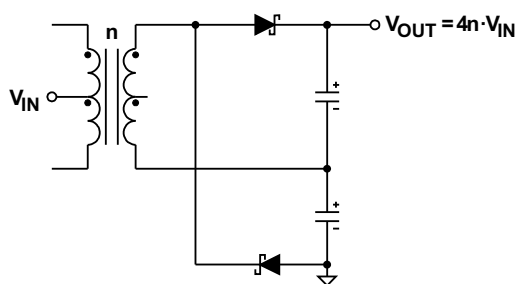

Figure 9-11. Half-Wave Rectifier Without Centered Ground and Center-Tapped Secondary Performs Voltage Doubling Twice, Hence Quadrupling V_{IN}

9.2.4.2 Application Circuits

The following application circuits are shown for a 3.3 V input supply commonly taken from the local, regulated microcontroller supply. For 5 V input voltages requiring different turn ratios refer to the transformer manufacturers and their web sites listed in Table 9-4.

Table 9-4. Transformer Manufacturers

MANUFACTURER	MORE INFORMATION
Coilcraft Inc.	http://www.coilcraft.com
Halo-Electronics Inc.	http://www.haloelectronics.com
Murata Power Solutions	http://www.murata-ps.com
Würth Electronics Midcom Inc	http://www.midcom-inc.com

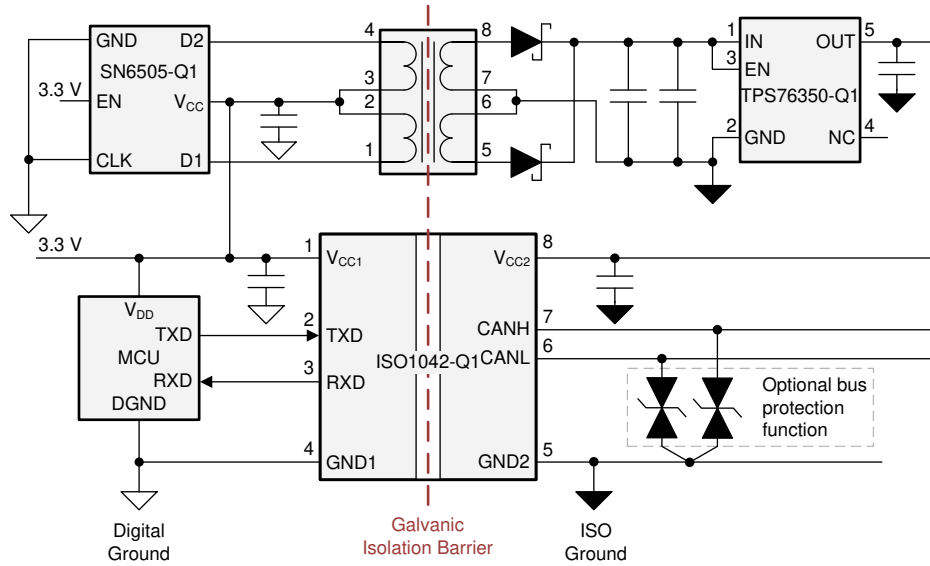

Figure 9-12. Isolated CAN Interface

10 Power Supply Recommendations

The device is designed to operate from an input voltage supply range between 2.5 V and 5 V nominal. This input supply must be regulated within $\pm 10\%$. If the input supply is located more than a few inches from the device, a 0.1 μF by-pass capacitor should be connected as close as possible to the device V_{CC} pin and a 10 μF capacitor should be connected close to the transformer center-tap pin.

11 Layout

11.1 Layout Guidelines

- The V_{IN} pin must be buffered to ground with a low-ESR ceramic bypass-capacitor. The recommended capacitor value can range from 1 μF to 10 μF . The capacitor must have a voltage rating of 10 V minimum and a X5R or X7R dielectric.
- The optimum placement is closest to the V_{IN} and GND pins at the board entrance to minimize the loop area formed by the bypass-capacitor connection, the V_{IN} terminal, and the GND pin. See [Figure 11-1](#) for a PCB layout example.
- The connections between the device D1 and D2 pins and the transformer primary endings, and the connection of the device V_{CC} pin and the transformer center-tap must be as close as possible for minimum trace inductance.
- The connection of the device V_{CC} pin and the transformer center-tap must be buffered to ground with a low-ESR ceramic bypass-capacitor. The recommended capacitor value can range from 1 μF to 10 μF . The capacitor must have a voltage rating of 16 V minimum and a X5R or X7R dielectric.
- The device GND pins must be tied to the PCB ground plane using two vias for minimum inductance.
- The ground connections of the capacitors and the ground plane should use two vias for minimum inductance.
- The rectifier diodes should be Schottky diodes with low forward voltage in the 10 mA to 100 mA current range to maximize efficiency.
- The V_{OUT} pin must be buffered to ISO-Ground with a low-ESR ceramic bypass-capacitor. The recommended capacitor value can range from 1 μF to 10 μF . The capacitor must have a voltage rating of 16 V minimum and a X5R or X7R dielectric.

11.2 Layout Example

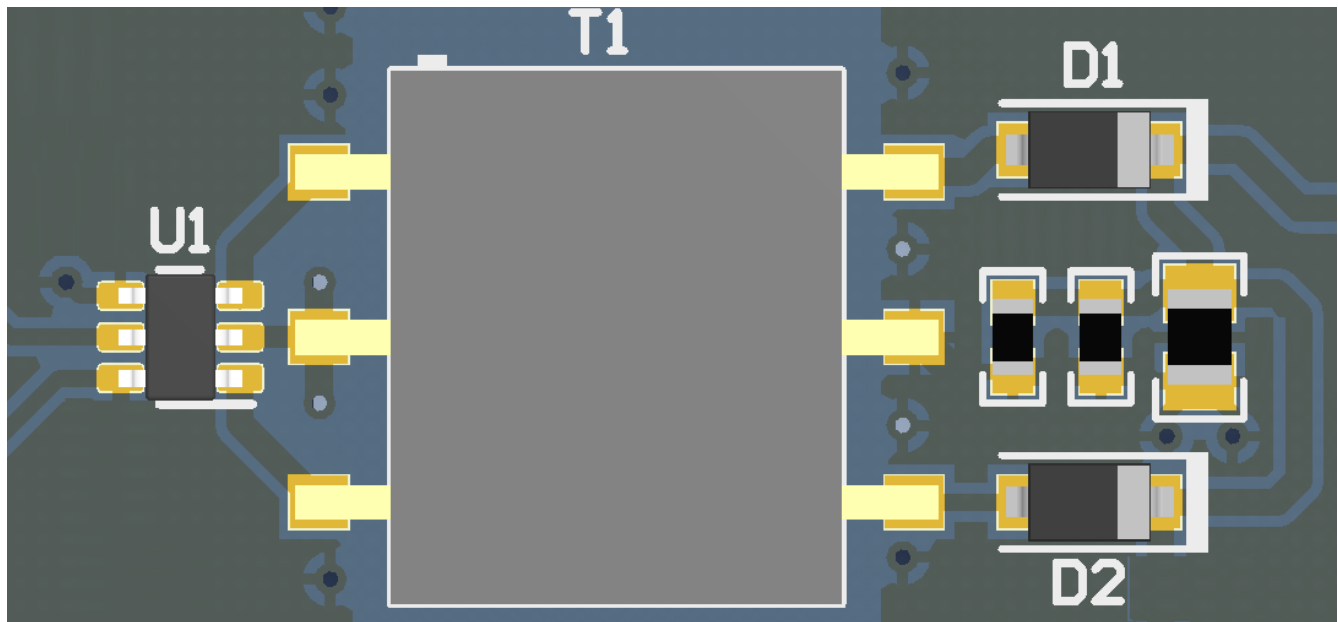

Figure 11-1. Layout Example of a 2-Layer Board

12 Device and Documentation Support

12.1 Device Support

12.1.1 Third-Party Products Disclaimer

TI'S PUBLICATION OF INFORMATION REGARDING THIRD-PARTY PRODUCTS OR SERVICES DOES NOT CONSTITUTE AN ENDORSEMENT REGARDING THE SUITABILITY OF SUCH PRODUCTS OR SERVICES OR A WARRANTY, REPRESENTATION OR ENDORSEMENT OF SUCH PRODUCTS OR SERVICES, EITHER ALONE OR IN COMBINATION WITH ANY TI PRODUCT OR SERVICE.

12.2 Documentation Support

12.2.1 Related Documentation

For related documentation see the following:

- Texas Instruments, [Digital Isolator Design Guide](#)
- Texas Instruments, [Isolation Glossary](#)
- Texas Instruments, [How to Isolate Signal and Power in Isolated CAN Systems TI TechNote](#)
- Texas Instruments, [Small Form-Factor Reinforced Isolated IGBT Gate Drive Reference Design for 3-Phase Inverter TI Design](#)

12.3 Related Links

The table below lists quick access links. Categories include technical documents, support and community resources, tools and software, and quick access to order now.

Table 12-1. Related Links

PARTS	PRODUCT FOLDER	ORDER NOW	TECHNICAL DOCUMENTS	TOOLS & SOFTWARE	SUPPORT & COMMUNITY
SN6505A-Q1	Click here	Click here	Click here	Click here	Click here
SN6505B-Q1	Click here	Click here	Click here	Click here	Click here
SN6505D-Q1	Click here	Click here	Click here	Click here	Click here

12.4 Receiving Notification of Documentation Updates

To receive notification of documentation updates, navigate to the device product folder on [ti.com](#). Click on *Subscribe to updates* to register and receive a weekly digest of any product information that has changed. For change details, review the revision history included in any revised document.

12.5 Support Resources

[TI E2E™ support forums](#) are an engineer's go-to source for fast, verified answers and design help — straight from the experts. Search existing answers or ask your own question to get the quick design help you need.

Linked content is provided "AS IS" by the respective contributors. They do not constitute TI specifications and do not necessarily reflect TI's views; see TI's [Terms of Use](#).

12.6 Trademarks

TI E2E™ is a trademark of Texas Instruments.
All trademarks are the property of their respective owners.

12.7 Electrostatic Discharge Caution



This integrated circuit can be damaged by ESD. Texas Instruments recommends that all integrated circuits be handled with appropriate precautions. Failure to observe proper handling and installation procedures can cause damage.

ESD damage can range from subtle performance degradation to complete device failure. Precision integrated circuits may be more susceptible to damage because very small parametric changes could cause the device not to meet its published specifications.

12.8 Glossary

TI Glossary This glossary lists and explains terms, acronyms, and definitions.

13 Mechanical, Packaging, and Orderable Information

The following pages include mechanical, packaging, and orderable information. This information is the most current data available for the designated devices. This data is subject to change without notice and revision of this document. For browser-based versions of this data sheet, refer to the left-hand navigation.

PACKAGING INFORMATION

Orderable Device	Status (1)	Package Type	Package Drawing	Pins	Package Qty	Eco Plan (2)	Lead finish/ Ball material (6)	MSL Peak Temp (3)	Op Temp (°C)	Device Marking (4/5)	Samples
SN6505AQDBVRQ1	ACTIVE	SOT-23	DBV	6	3000	RoHS & Green	NIPDAU NIPDAUAG	Level-2-260C-1 YEAR	-40 to 125	65AQ	Samples
SN6505AQDBVTQ1	ACTIVE	SOT-23	DBV	6	250	RoHS & Green	NIPDAU NIPDAUAG	Level-2-260C-1 YEAR	-40 to 125	65AQ	Samples
SN6505BQDBVRQ1	ACTIVE	SOT-23	DBV	6	3000	RoHS & Green	NIPDAU NIPDAUAG	Level-2-260C-1 YEAR	-40 to 125	65BQ	Samples
SN6505BQDBVTQ1	ACTIVE	SOT-23	DBV	6	250	RoHS & Green	NIPDAU NIPDAUAG	Level-2-260C-1 YEAR	-40 to 125	65BQ	Samples
SN6505DQDBVRQ1	ACTIVE	SOT-23	DBV	6	3000	RoHS & Green	NIPDAU NIPDAUAG	Level-2-260C-1 YEAR	-40 to 125	65DQ	Samples
SN6505DQDBVTQ1	ACTIVE	SOT-23	DBV	6	250	RoHS & Green	NIPDAU NIPDAUAG	Level-2-260C-1 YEAR	-40 to 125	65DQ	Samples

(1) The marketing status values are defined as follows:

ACTIVE: Product device recommended for new designs.

LIFEBUY: TI has announced that the device will be discontinued, and a lifetime-buy period is in effect.

NRND: Not recommended for new designs. Device is in production to support existing customers, but TI does not recommend using this part in a new design.

PREVIEW: Device has been announced but is not in production. Samples may or may not be available.

OBSOLETE: TI has discontinued the production of the device.

(2) **RoHS:** TI defines "RoHS" to mean semiconductor products that are compliant with the current EU RoHS requirements for all 10 RoHS substances, including the requirement that RoHS substance do not exceed 0.1% by weight in homogeneous materials. Where designed to be soldered at high temperatures, "RoHS" products are suitable for use in specified lead-free processes. TI may reference these types of products as "Pb-Free".

RoHS Exempt: TI defines "RoHS Exempt" to mean products that contain lead but are compliant with EU RoHS pursuant to a specific EU RoHS exemption.

Green: TI defines "Green" to mean the content of Chlorine (Cl) and Bromine (Br) based flame retardants meet JS709B low halogen requirements of <=1000ppm threshold. Antimony trioxide based flame retardants must also meet the <=1000ppm threshold requirement.

(3) MSL, Peak Temp. - The Moisture Sensitivity Level rating according to the JEDEC industry standard classifications, and peak solder temperature.

(4) There may be additional marking, which relates to the logo, the lot trace code information, or the environmental category on the device.

(5) Multiple Device Markings will be inside parentheses. Only one Device Marking contained in parentheses and separated by a "-" will appear on a device. If a line is indented then it is a continuation of the previous line and the two combined represent the entire Device Marking for that device.

(6) Lead finish/Ball material - Orderable Devices may have multiple material finish options. Finish options are separated by a vertical ruled line. Lead finish/Ball material values may wrap to two lines if the finish value exceeds the maximum column width.

Important Information and Disclaimer: The information provided on this page represents TI's knowledge and belief as of the date that it is provided. TI bases its knowledge and belief on information provided by third parties, and makes no representation or warranty as to the accuracy of such information. Efforts are underway to better integrate information from third parties. TI has taken and continues to take reasonable steps to provide representative and accurate information but may not have conducted destructive testing or chemical analysis on incoming materials and chemicals. TI and TI suppliers consider certain information to be proprietary, and thus CAS numbers and other limited information may not be available for release.

In no event shall TI's liability arising out of such information exceed the total purchase price of the TI part(s) at issue in this document sold by TI to Customer on an annual basis.

OTHER QUALIFIED VERSIONS OF SN6505A-Q1, SN6505B-Q1 :

- Catalog : [SN6505A](#), [SN6505B](#)

NOTE: Qualified Version Definitions:

- Catalog - TI's standard catalog product

TAPE AND REEL INFORMATION



QUADRANT ASSIGNMENTS FOR PIN 1 ORIENTATION IN TAPE

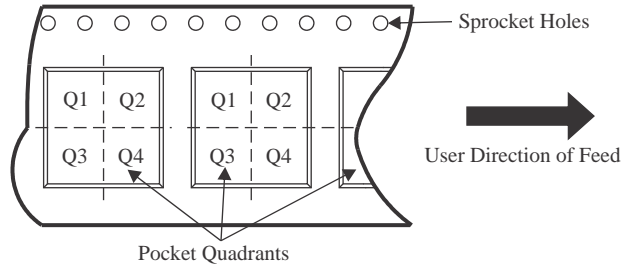

*All dimensions are nominal

Device	Package Type	Package Drawing	Pins	SPQ	Reel Diameter (mm)	Reel Width W1 (mm)	A0 (mm)	B0 (mm)	K0 (mm)	P1 (mm)	W (mm)	Pin1 Quadrant
SN6505AQDBVRQ1	SOT-23	DBV	6	3000	180.0	8.4	3.2	3.2	1.4	4.0	8.0	Q3
SN6505AQDBVTQ1	SOT-23	DBV	6	250	180.0	8.4	3.2	3.2	1.4	4.0	8.0	Q3
SN6505BQDBVRQ1	SOT-23	DBV	6	3000	180.0	8.4	3.23	3.17	1.37	4.0	8.0	Q3
SN6505BQDBVRQ1	SOT-23	DBV	6	3000	180.0	8.4	3.2	3.2	1.4	4.0	8.0	Q3
SN6505BQDBVTQ1	SOT-23	DBV	6	250	180.0	8.4	3.2	3.2	1.4	4.0	8.0	Q3
SN6505DQDBVRQ1	SOT-23	DBV	6	3000	180.0	8.4	3.23	3.17	1.37	4.0	8.0	Q3
SN6505DQDBVRQ1	SOT-23	DBV	6	3000	180.0	8.4	3.2	3.2	1.4	4.0	8.0	Q3
SN6505DQDBVTQ1	SOT-23	DBV	6	250	180.0	8.4	3.2	3.2	1.4	4.0	8.0	Q3

TAPE AND REEL BOX DIMENSIONS

*All dimensions are nominal

Device	Package Type	Package Drawing	Pins	SPQ	Length (mm)	Width (mm)	Height (mm)
SN6505AQDBVRQ1	SOT-23	DBV	6	3000	210.0	185.0	35.0
SN6505AQDBVTQ1	SOT-23	DBV	6	250	210.0	185.0	35.0
SN6505BQDBVRQ1	SOT-23	DBV	6	3000	213.0	191.0	35.0
SN6505BQDBVRQ1	SOT-23	DBV	6	3000	210.0	185.0	35.0
SN6505BQDBVTQ1	SOT-23	DBV	6	250	210.0	185.0	35.0
SN6505DQDBVRQ1	SOT-23	DBV	6	3000	213.0	191.0	35.0
SN6505DQDBVRQ1	SOT-23	DBV	6	3000	210.0	185.0	35.0
SN6505DQDBVTQ1	SOT-23	DBV	6	250	210.0	185.0	35.0



DBV0006A

PACKAGE OUTLINE

SOT-23 - 1.45 mm max height

SMALL OUTLINE TRANSISTOR

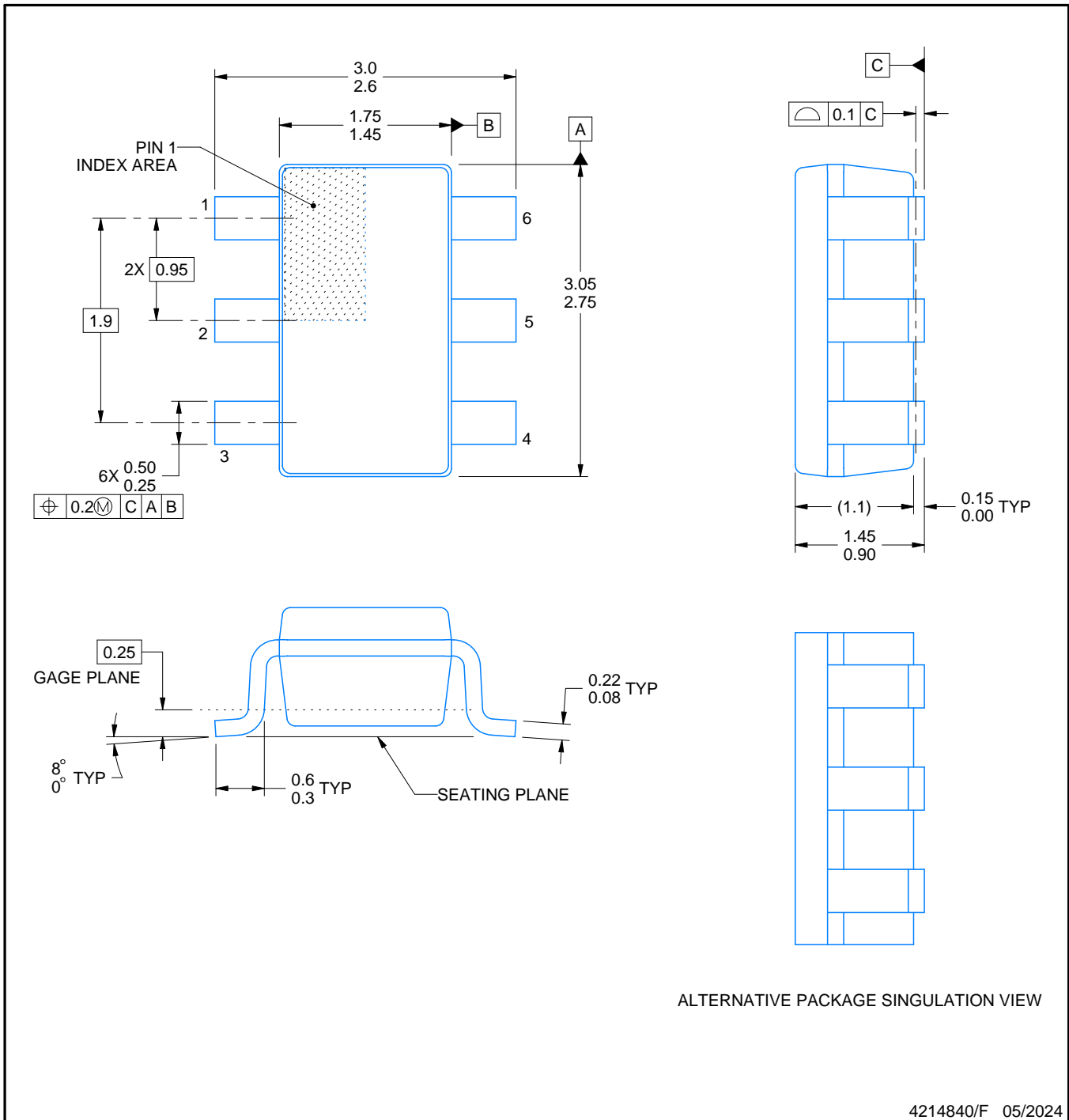

4214840/F 05/2024

NOTES:

1. All linear dimensions are in millimeters. Any dimensions in parenthesis are for reference only. Dimensioning and tolerancing per ASME Y14.5M.
2. This drawing is subject to change without notice.
3. Body dimensions do not include mold flash or protrusion. Mold flash and protrusion shall not exceed 0.25 per side.
4. Leads 1,2,3 may be wider than leads 4,5,6 for package orientation.
5. Reference JEDEC MO-178.

EXAMPLE BOARD LAYOUT

DBV0006A

SOT-23 - 1.45 mm max height

SMALL OUTLINE TRANSISTOR

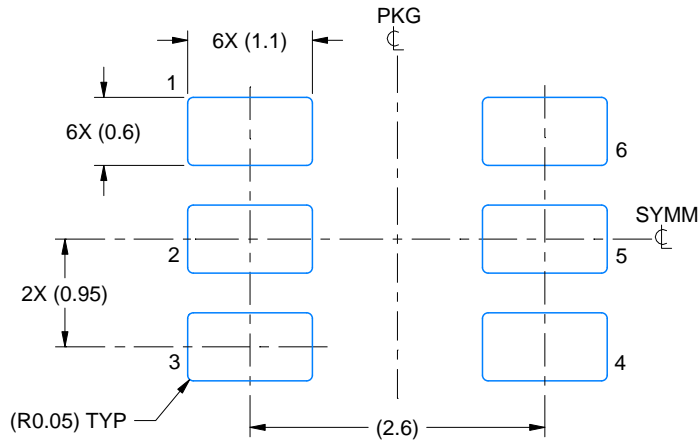

LAND PATTERN EXAMPLE
EXPOSED METAL SHOWN
SCALE:15X

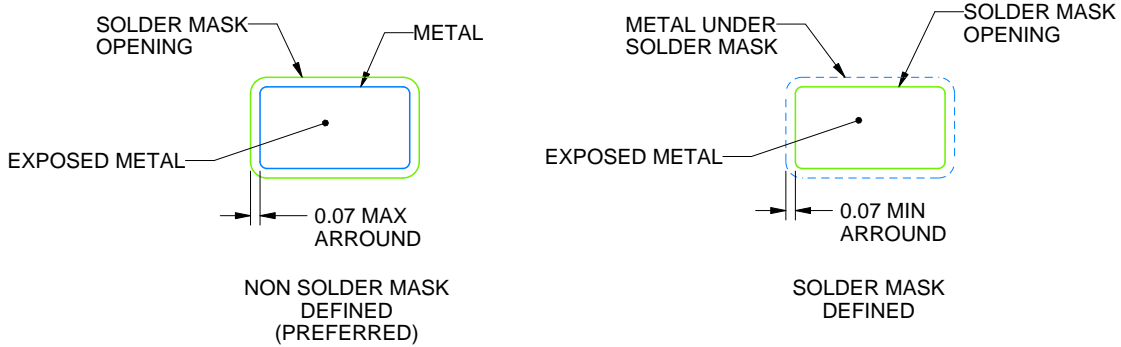

SOLDER MASK DETAILS

4214840/F 05/2024

NOTES: (continued)

- 6. Publication IPC-7351 may have alternate designs.
- 7. Solder mask tolerances between and around signal pads can vary based on board fabrication site.

EXAMPLE STENCIL DESIGN

DBV0006A

SOT-23 - 1.45 mm max height

SMALL OUTLINE TRANSISTOR

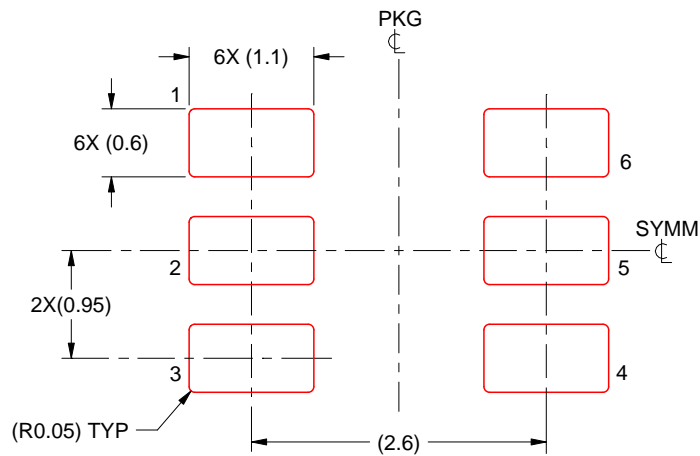

SOLDER PASTE EXAMPLE
BASED ON 0.125 mm THICK STENCIL
SCALE:15X

4214840/F 05/2024

NOTES: (continued)

8. Laser cutting apertures with trapezoidal walls and rounded corners may offer better paste release. IPC-7525 may have alternate design recommendations.
9. Board assembly site may have different recommendations for stencil design.

IMPORTANT NOTICE AND DISCLAIMER

TI PROVIDES TECHNICAL AND RELIABILITY DATA (INCLUDING DATA SHEETS), DESIGN RESOURCES (INCLUDING REFERENCE DESIGNS), APPLICATION OR OTHER DESIGN ADVICE, WEB TOOLS, SAFETY INFORMATION, AND OTHER RESOURCES "AS IS" AND WITH ALL FAULTS, AND DISCLAIMS ALL WARRANTIES, EXPRESS AND IMPLIED, INCLUDING WITHOUT LIMITATION ANY IMPLIED WARRANTIES OF MERCHANTABILITY, FITNESS FOR A PARTICULAR PURPOSE OR NON-INFRINGEMENT OF THIRD PARTY INTELLECTUAL PROPERTY RIGHTS.

These resources are intended for skilled developers designing with TI products. You are solely responsible for (1) selecting the appropriate TI products for your application, (2) designing, validating and testing your application, and (3) ensuring your application meets applicable standards, and any other safety, security, regulatory or other requirements.

These resources are subject to change without notice. TI grants you permission to use these resources only for development of an application that uses the TI products described in the resource. Other reproduction and display of these resources is prohibited. No license is granted to any other TI intellectual property right or to any third party intellectual property right. TI disclaims responsibility for, and you will fully indemnify TI and its representatives against, any claims, damages, costs, losses, and liabilities arising out of your use of these resources.

TI's products are provided subject to [TI's Terms of Sale](#) or other applicable terms available either on [ti.com](https://www.ti.com) or provided in conjunction with such TI products. TI's provision of these resources does not expand or otherwise alter TI's applicable warranties or warranty disclaimers for TI products.

TI objects to and rejects any additional or different terms you may have proposed.

Mailing Address: Texas Instruments, Post Office Box 655303, Dallas, Texas 75265
Copyright © 2024, Texas Instruments Incorporated

Looking for pricing, stock, or lifecycle information?

Click below to explore more details on WIN SOURCE:

- ⊖ [View DF11-2428SCA on WIN SOURCE](#)
- ⊖ [Hirose Electric Co Ltd Information](#)

Optimize Your Supply Chain with WIN SOURCE Solutions

- ✓ Global Sourcing Solution
- ✓ Obsolete Management
- ✓ Cost Control Management
- ✓ Shortage Management
- ✓ Alternative Solution
- ✓ Excess Inventory Management