



**THE DATASHEET OF
DF17(1.0H)-70DP-0.5V(57)**



0.5mm Pitch Board to Board Connector

DF17 Series

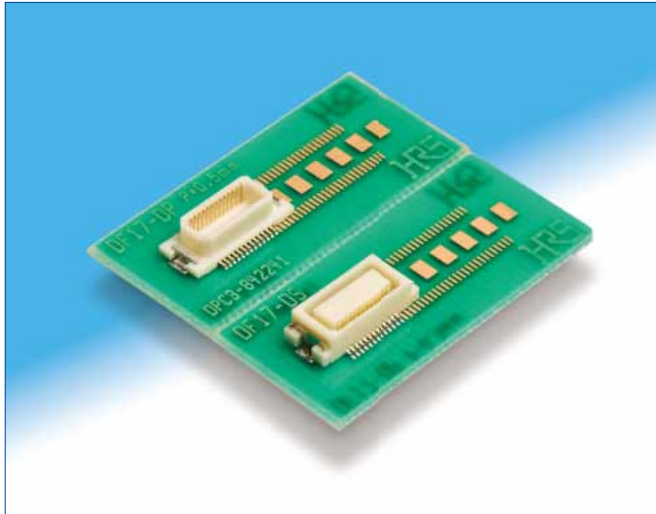

■ Features

1. Withstands Drop Impact or Shock

- All 4 sides covered by box design
- Bellows contacts strong against vibration
- Convex on receptacle increases strength enhance shock-proof, pinch-proof and scoop-proof performance. (Fig.1)(Fig.2)

2. With Metal Fitting available

In order to grade up the strength against the mechanical stress, the metal fitting specification is also available.

3. Wide Variety of No. of Positions

The connectors are lined up per 10 contacts from 20 to 80 pos. to take countermeasures for multi-signalization.

4. Stacking Height 4 to 8mm

The stacking height can be selected (per millimeter) between 4mm and 8mm in combination of the receptacle with the header.

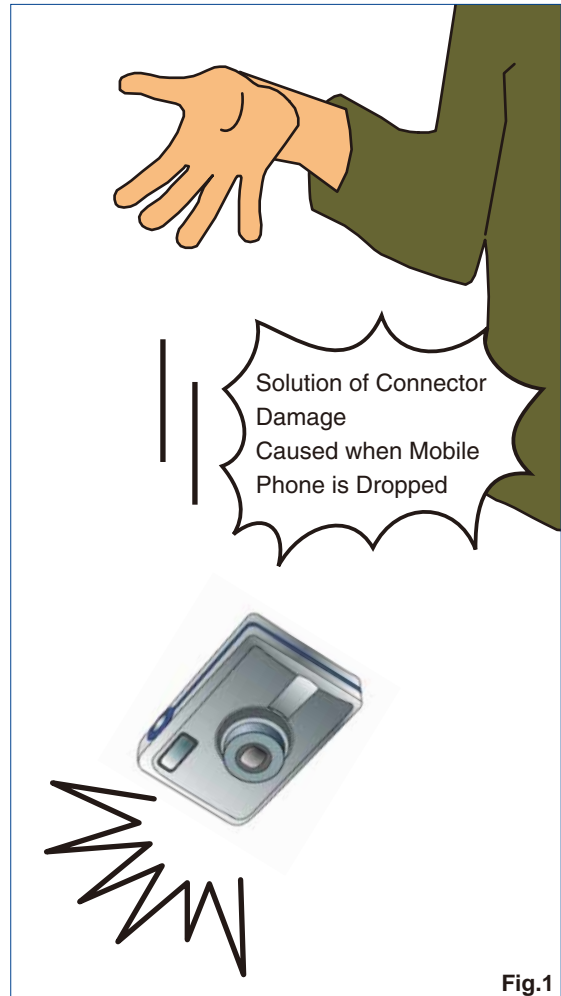

Fig.1

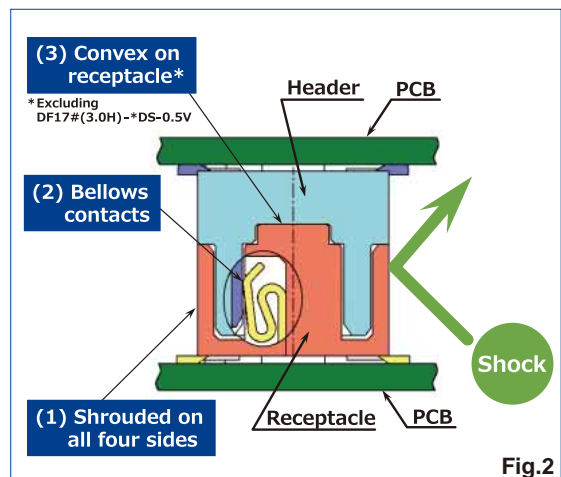
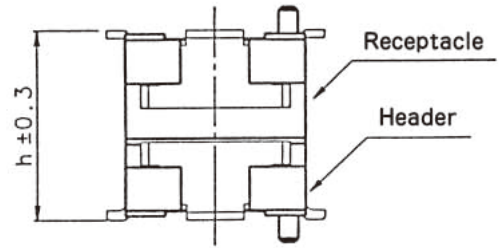
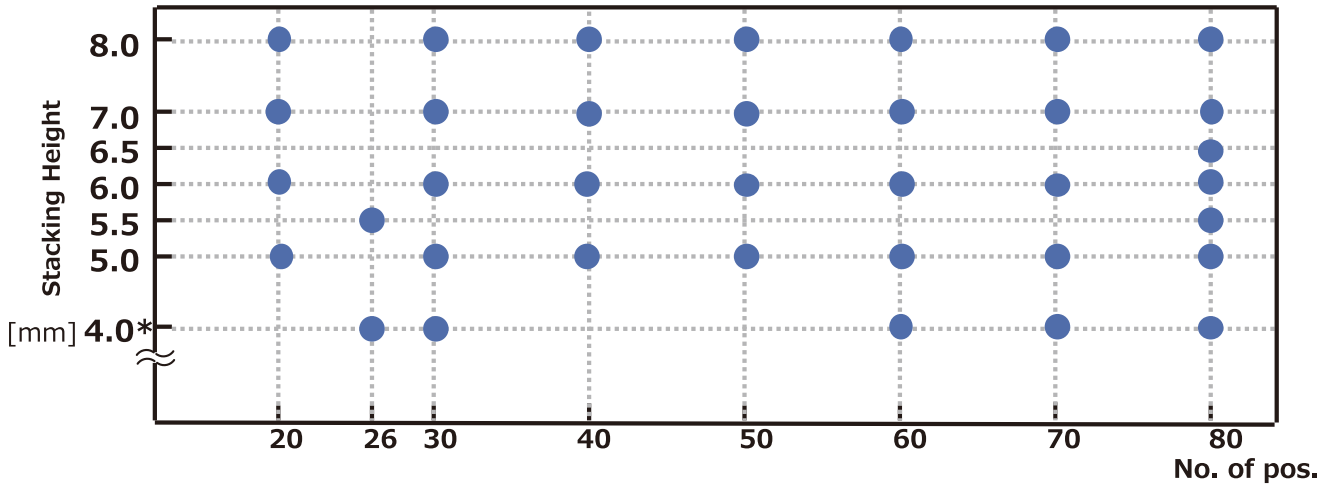





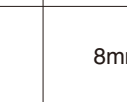



Fig.2



		DF17#(□)-*DS-0.5V	
		3.0	4.0
DF17#(□)-*DP-0.5V	2.0		
	5mm	5mm	6mm
	2.5		
5.5mm	5.5mm	6.5mm	
4.0			
7mm	7mm	8mm	

		DF17(3.0H)-*DS-0.5V	
			
DF17(1.0H)-*DP-0.5V			
	4mm		

Note : The stacking height doesn't include the solder paste thickness.

Applications

Mobile phones, LCD, miniature equipment and so on

Product Specifications

Rating	Current rating Voltage rating	0.3A 50V AC	Operating Temperature Range Operating Humidity Range	-35 to 85°C (Note 1) 40 to 80%	Storage Temperature Range Storage Humidity Range	-10 to 60°C (Note 2) 40 to 70%
--------	----------------------------------	----------------	---	-----------------------------------	---	-----------------------------------

Items	Specifications	Conditions
1. Insulation Resistance	500MΩ min.	100V DC
2. Withstanding voltage	No flashover or insulation breakdown.	150V AC/1 minute
3. Contact Resistance	60mΩ max.	100mA
4. Vibration	No electrical discontinuity of 1μs or more	Frequency : 10 to 55 Hz, single amplitude of 0.75mm, 2 hours in each of the 3 directions.
5. Humidity (Steady state)	Contact resistance : 60mΩ max. Insulation resistance : 250MΩ min.	96 hours at temperature of 40°C and humidity of 90% to 95%
6. Temperature Cycle	Contact resistance : 60mΩ max. Insulation resistance : 500MΩ min.	(-55°C : 30 minutes 5 to 35°C : 10 minutes 85°C : 30 minutes 5 to 35°C : 10 minutes) 5 cycles
7. Durability (Mating/un-mating)	Contact resistance : 60mΩ	50 cycles
8. Resistance to Soldering heat	No deformation of components affecting performance.	Reflow : At the recommended temperature profile Manual soldering : 350°C for 3 seconds

Note 1 : Includes temperature rise caused by current flow.

Note 2 : The term "storage" refers to products stored for long period of time prior to mounting and use. Operating Temperature Range and Humidity range covers non conducting condition of installed connectors in storage, shipment or during transportation.

Note 3 : Information contained in this catalog represents general requirements for this Series. Contact us for the drawings and specifications for a specific part number shown.

Materials / Finish

Product	Part	Material	Finish	Remarks
Receptacle	Insulator	Polyamide	White	UL94V-0
	Contact	Phosphor copper	Gold plated (Note 1)	————
	Solder tab	Phosphor copper	Tin-lead plated	————
Header	Insulator	Polyamide	White	UL94V-0
	Contact	Phosphor copper	Gold plated (Note 2)	————
	Solder tab	Phosphor copper	Tin-lead plated	————

Note1 : DF17(0.3)-*DS-0.5V : Contact area : gold plating/lead area : flash gold plated

DF17(4.0)-*DS-0.5V : Contact area : gold plating/lead area : tin plated

DF17(4.0)-*DP-0.5V : Contact area : gold plating/lead area : tin plated

Note2 : The header gold plated product : Contact area : gold plating/lead area : tin plated

DF17(1.0H)-*DS-0.5V only : Contact area : gold plating/lead area : flash gold plated

Product Number Structure

Refer to the chart below when determining the product specifications from the product number.

Please select from the product numbers listed in this catalog when placing orders.

●Receptacle/Header

DF17 **#** **(**)** - *** DS - 0.5 V** **(**)**

①
②
③
④
⑤
⑥
⑦
⑧

① Series Name : DF17 ② Type <table border="1" style="margin-left: 20px;"> <thead> <tr> <th></th> <th>Solder tab</th> <th>Boss</th> </tr> </thead> <tbody> <tr> <td>DF17</td> <td style="text-align: center;">○</td> <td style="text-align: center;">○</td> </tr> <tr> <td>DF17B</td> <td style="text-align: center;">○</td> <td style="text-align: center;">×</td> </tr> </tbody> </table>		Solder tab	Boss	DF17	○	○	DF17B	○	×	④ Number of Pos. 20, 26, 30, 40, 50, 60, 70, 80 contacts ⑤ Connector Type DS : Receptacle DP : Header ⑥ Contact Pitch : 0.5mm ⑦ Contact Style V : Straight SMT ⑧ Packaging Type (57) : Gold plated,embossed tape packaging
	Solder tab	Boss								
DF17	○	○								
DF17B	○	×								
③ Product height The stacking height can be determined by adding the figures in parentheses to receptacle and header.										

Receptacle With Solder Tab

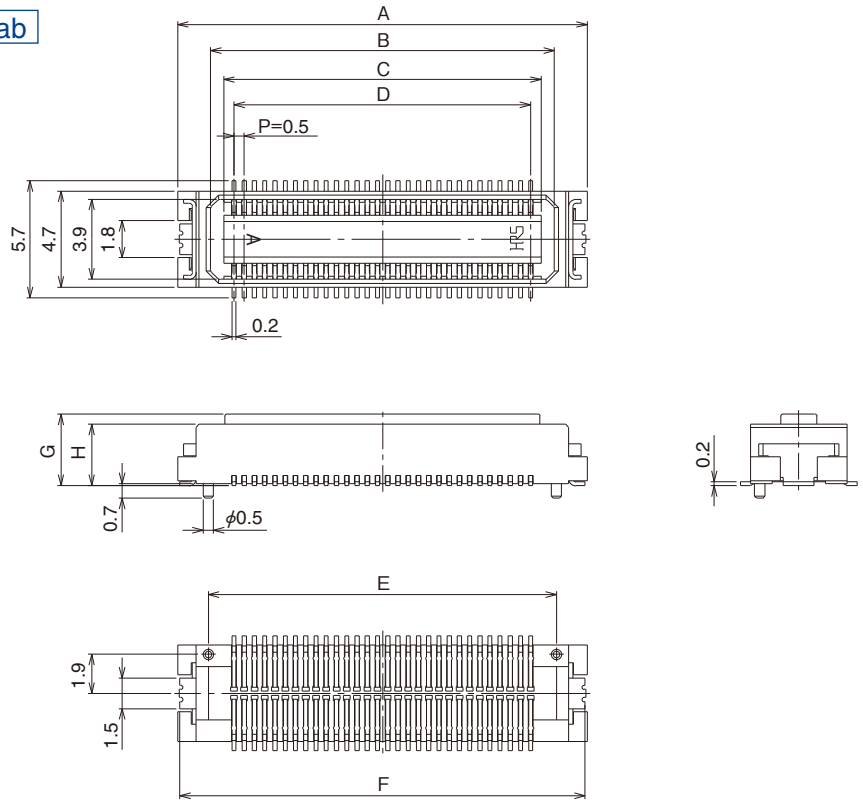

● Stacking Height : 4mm

Part No.	HRS No.	Number of Pos.	A	B	C	D	E	F	G	H	RoHS
DF17(3.0H)-26DS-0.5V(57)	683-0253-2 57	26	11.5	8.3	7.0	6.0	8.5	11.3	3.0	3.0	YES
DF17(3.0H)-30DS-0.5V(57)	683-0268-0 57	30	12.5	9.3	8.0	7.0	9.5	12.3			
DF17(3.0H)-60DS-0.5V(57)	683-0361-5 57	60	20.0	16.8	15.5	14.5	17.0	19.8			
DF17(3.0H)-70DS-0.5V(57)	683-0393-1 57	70	22.5	19.3	18.0	17.0	19.5	22.3			
DF17(3.0H)-80DS-0.5V(57)	683-0369-7 57	80	25.0	21.8	20.5	19.5	22.0	24.8			

● Stacking Height : 5mm, 7mm

Part No.	HRS No.	Number of Pos.	A	B	C	D	E	F	G	H	RoHS
DF17(3.0)-20DS-0.5V(57)	683-0002-2 57	20	10.0	6.8	5.5	4.5	7.0	9.8	3.5	3.0	YES
DF17(3.0)-26DS-0.5V(57)	683-0241-3 57	26	11.5	8.3	7.0	6.0	8.5	11.3			
DF17(3.0)-30DS-0.5V(57)	683-0003-5 57	30	12.5	9.3	8.0	7.0	9.5	12.3			
DF17(3.0)-40DS-0.5V(57)	683-0004-8 57	40	15.0	11.8	10.5	9.5	12.0	14.8			
DF17(3.0)-50DS-0.5V(57)	683-0005-0 57	50	17.5	14.3	13.0	12.0	14.5	17.3			
DF17(3.0)-60DS-0.5V(57)	683-0006-3 57	60	20.0	16.8	15.5	14.5	17.0	19.8			
DF17(3.0)-70DS-0.5V(57)	683-0007-6 57	70	22.5	19.3	18.0	17.0	19.5	22.3			
DF17(3.0)-80DS-0.5V(57)	683-0008-9 57	80	25.0	21.8	20.5	19.5	22.0	24.8			

● Stacking Height : 6mm, 8mm

Part No.	HRS No.	Number of Pos.	A	B	C	D	E	F	G	H	RoHS
DF17(4.0)-20DS-0.5V(57)	683-0042-7 57	20	10.0	6.8	5.5	4.5	7.0	9.8	4.5	4.0	YES
DF17(4.0)-30DS-0.5V(57)	683-0043-0 57	30	12.5	9.3	8.0	7.0	9.5	12.3			
DF17(4.0)-40DS-0.5V(57)	683-0044-2 57	40	15.0	11.8	10.5	9.5	12.0	14.8			
DF17(4.0)-50DS-0.5V(57)	683-0045-5 57	50	17.5	14.3	13.0	12.0	14.5	17.3			
DF17(4.0)-60DS-0.5V(57)	683-0046-8 57	60	20.0	16.8	15.5	14.5	17.0	19.8			
DF17(4.0)-70DS-0.5V(57)	683-0047-0 57	70	22.5	19.3	18.0	17.0	19.5	22.3			
DF17(4.0)-80DS-0.5V(57)	683-0048-3 57	80	25.0	21.8	20.5	19.5	22.0	24.8			

Note 1 : In regard to this product, the embossed tape packaging is the standard packaging. (1000 pcs./ reel.)

Note 2 : If the without boss specification is required, please contact HRS sales department.

Header With Solder Tab

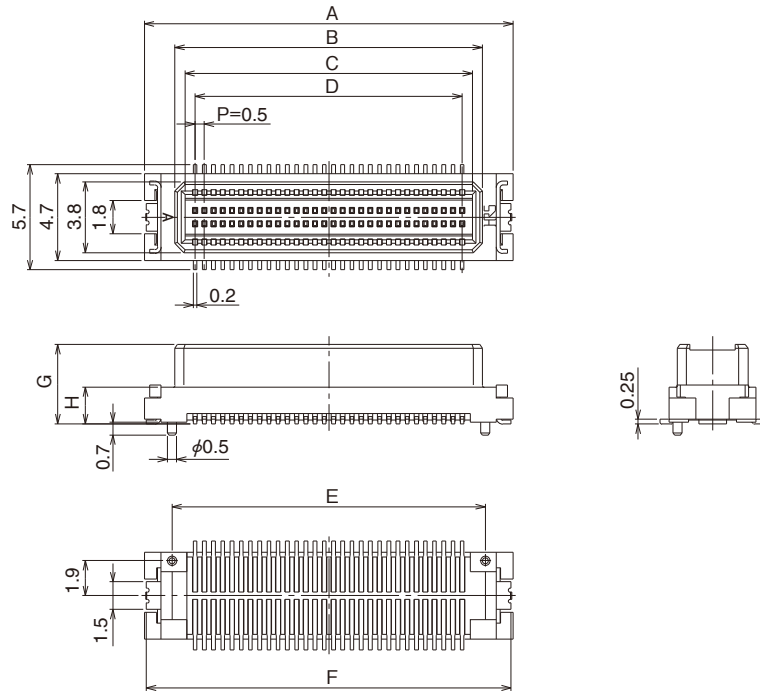

● Stacking Height : 4mm

Part No.	HRS No.	Number of Pos.	A	B	C	D	E	F	G	H	RoHS
DF17(1.0H)-26DP-0.5V(57)	683-0257-3 57	26	11.5	8.2	7.1	6.0	8.5	11.3	3.3	1.0	YES
DF17(1.0H)-30DP-0.5V(57)	683-0272-7 57	30	12.5	9.2	8.1	7.0	9.5	12.3			
DF17(1.0H)-60DP-0.5V(57)	683-0365-6 57	60	20.0	16.7	15.6	14.5	17.0	19.8			
DF17(1.0H)-70DP-0.5V(57)	683-0397-2 57	70	22.5	19.2	18.1	17.0	19.5	22.3			
DF17(1.0H)-80DP-0.5V(57)	683-0373-4 57	80	25.0	21.7	20.6	19.5	22.0	24.8			

● Stacking Height : 5mm, 6mm

Part No.	HRS No.	Number of Pos.	A	B	C	D	E	F	G	H	RoHS
DF17(2.0)-20DP-0.5V(57)	683-0082-1 57	20	10.0	6.7	5.6	4.5	7.0	9.8	4.3	2.0	YES
DF17(2.0)-30DP-0.5V(57)	683-0083-4 57	30	12.5	9.2	8.1	7.0	9.5	12.3			
DF17(2.0)-40DP-0.5V(57)	683-0084-7 57	40	15.0	11.7	10.6	9.5	12.0	14.8			
DF17(2.0)-50DP-0.5V(57)	683-0085-0 57	50	17.5	14.2	13.1	12.0	14.5	17.3			
DF17(2.0)-60DP-0.5V(57)	683-0086-2 57	60	20.0	16.7	15.6	14.5	17.0	19.8			
DF17(2.0)-70DP-0.5V(57)	683-0087-5 57	70	22.5	19.2	18.1	17.0	19.5	22.3			
DF17(2.0)-80DP-0.5V(57)	683-0088-8 57	80	25.0	21.7	20.6	19.5	22.0	24.8			

● Stacking Height : 7mm, 8mm

Part No.	HRS No.	Number of Pos.	A	B	C	D	E	F	G	H	RoHS
DF17(4.0)-20DP-0.5V(57)	683-0122-4 57	20	10.0	6.7	5.6	4.5	7.0	9.8	6.3	4.0	YES
DF17(4.0)-30DP-0.5V(57)	683-0123-7 57	30	12.5	9.2	8.1	7.0	9.5	12.3			
DF17(4.0)-40DP-0.5V(57)	683-0124-0 57	40	15.0	11.7	10.6	9.5	12.0	14.8			
DF17(4.0)-50DP-0.5V(57)	683-0125-2 57	50	17.5	14.2	13.1	12.0	14.5	17.3			
DF17(4.0)-60DP-0.5V(57)	683-0126-5 57	60	20.0	16.7	15.6	14.5	17.0	19.8			
DF17(4.0)-70DP-0.5V(57)	683-0127-8 57	70	22.5	19.2	18.1	17.0	19.5	22.3			
DF17(4.0)-80DP-0.5V(57)	683-0128-0 57	80	25.0	21.7	20.6	19.5	22.0	24.8			

● Stacking Height : 5.5mm, 6.5mm

Part No.	HRS No.	Number of Pos.	A	B	C	D	E	F	G	H	RoHS
DF17(2.5)-26DP-0.5V(57)	683-0245-4 57	26	11.5	8.2	7.1	6.0	8.5	11.3	4.8	2.5	YES
DF17(2.5)-80DP-0.5V(57)	683-0168-5 57	80	25.0	21.7	20.6	19.5	22.0	24.8			

Note 1 : In regard to this product, the embossed tape packaging is the standard packaging. (1000 pcs./reel.)

Note 2 : If the without boss specification is required, please contact HRS sales department.

PCB Mounting Pattern

- Receptacle
- Header

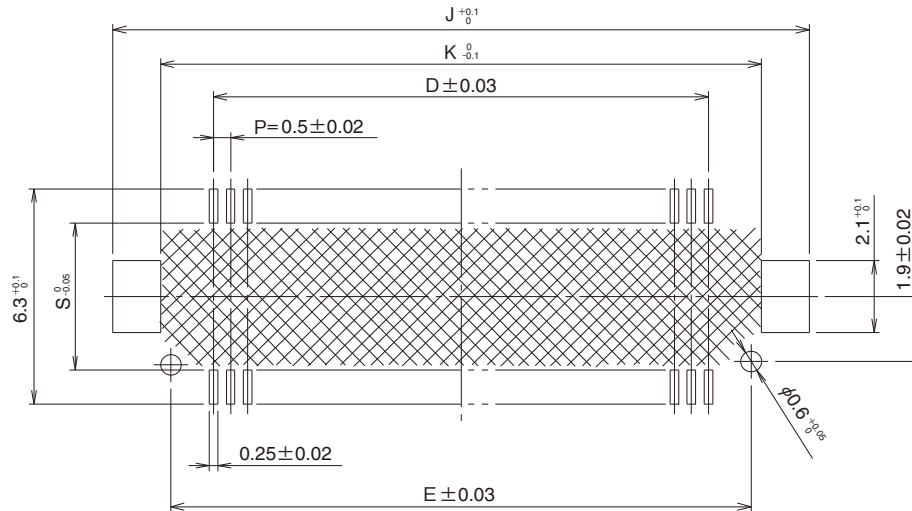

Number of Pos.	D	E	J	K
20	4.5	7.0	10.4	7.6
26	6.0	8.5	11.9	9.1
30	7.0	9.5	12.9	10.1
40	9.5	12.0	15.4	12.6
50	12.0	14.5	17.9	15.1
60	14.5	17.0	20.4	17.6
70	17.0	19.5	22.9	20.1
80	19.5	22.0	25.4	22.6

S	
Receptacle	4.3
Header	4

* The recommended solder paste thickness is 150μm.

Note 1 : If the pattern is included in the shaded area, and not treated with resist, it could touch the connector contact.

Note 2 : If the boss isn't included, the boss hole shown in the above figure isn't required.

■ Packaging Specification

● Embossed Carrier Tape Dimensions

■ Receptacle

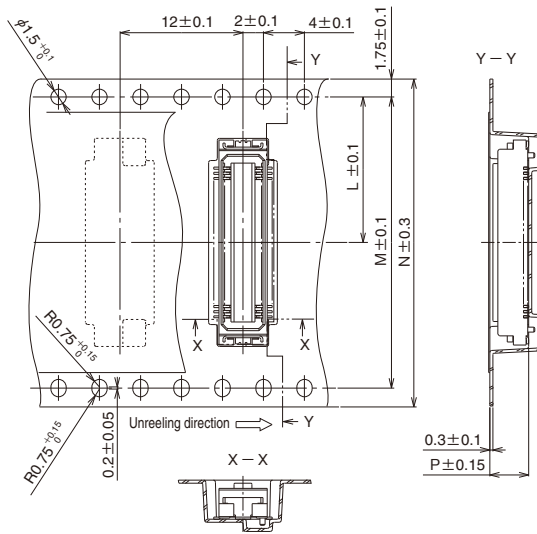

Connector	L	M	P	Q	R
DF17#(3.0)-20DS-0.5V	11.5	24	3.8	25.5	330
DF17#(3.0)-30DS-0.5V	11.5	24	3.8	25.5	330
DF17#(3.0)-40DS-0.5V	11.5	24	3.8	25.5	330
DF17#(3.0)-26DS-0.5V	11.5	24	3.8	25.5	330

Connector	L	M	N	P	Q	R
DF17#(3.0)-50DS-0.5V	14.2	28.4	32	3.8	33.5	330
DF17#(3.0)-60DS-0.5V	14.2	28.4	32	3.8	33.5	330
DF17#(3.0)-70DS-0.5V	20.2	40.4	44	3.8	45.5	330
DF17#(3.0)-80DS-0.5V	20.2	40.4	44	3.8	45.5	330

Connector	L	N	P	Q	R
DF17#(4.0)-20DS-0.5V	11.5	24	4.8	25.5	330
DF17#(4.0)-30DS-0.5V	11.5	24	4.8	25.5	330
DF17#(4.0)-40DS-0.5V	11.5	24	4.8	25.5	330

Connector	L	M	N	P	Q	R
DF17#(4.0)-50DS-0.5V	14.2	28.4	32	4.8	33.5	330
DF17#(4.0)-60DS-0.5V	14.2	28.4	32	4.8	33.5	330
DF17#(4.0)-70DS-0.5V	20.2	40.4	44	4.8	45.5	330
DF17#(4.0)-80DS-0.5V	20.2	40.4	44	4.8	45.5	330

Connector	L	M	N	P	Q	R
DF17#(3.0)-26DS-0.5V	11.5	-	24	3.3	25.5	330
DF17#(3.0)-30DS-0.5V	11.5	-	24	3.3	25.5	330
DF17#(3.0)-60DS-0.5V	14.2	28.4	32	3.3	33.5	330
DF17#(3.0)-70DS-0.5V	20.2	40.4	44	3.3	45.5	330
DF17#(3.0)-80DS-0.5V	20.2	40.4	44	3.3	45.5	330

● Reel Dimensions

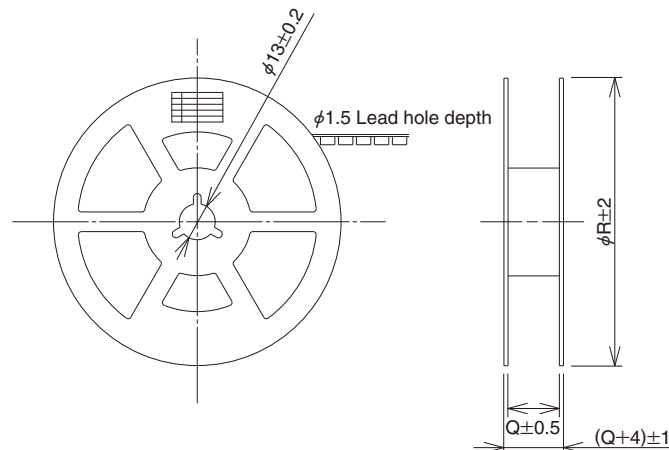

Header

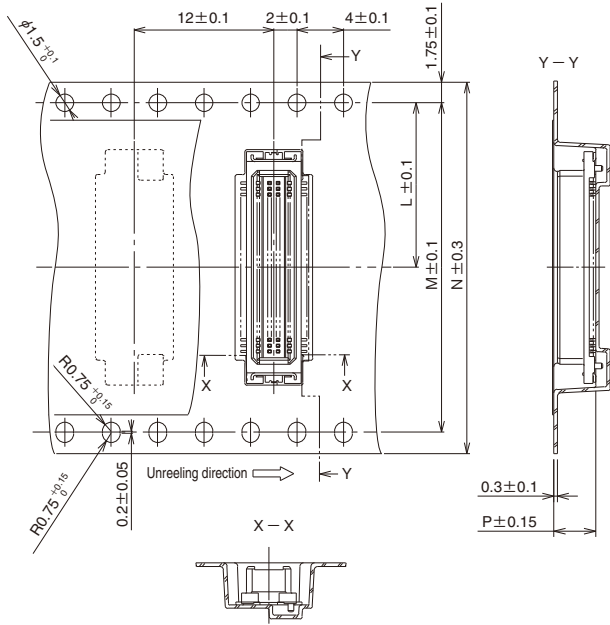

Connector	L	N	P	Q	R
DF17#(2.0)-20DP-0.5V	11.5	24	4.6	25.5	330
DF17#(2.0)-30DP-0.5V	11.5	24	4.6	25.5	330
DF17#(2.0)-40DP-0.5V	11.5	24	4.6	25.5	330
DF17#(2.5)-26DP-0.5V	11.5	24	5.1	25.5	330
DF17#(2.5)-80DP-0.5V	20.2	44	5.1	45.5	330

Connector	L	M	N	P	Q	R
DF17#(2.0)-50DP-0.5V	14.2	28.4	32	4.6	33.5	330
DF17#(2.0)-60DP-0.5V	14.2	28.4	32	4.6	33.5	330
DF17#(2.0)-70DP-0.5V	20.2	40.4	44	4.6	45.5	330
DF17#(2.0)-80DP-0.5V	20.2	40.4	44	4.6	45.5	330

Connector	L	N	P	Q	R
DF17#(4.0)-20DP-0.5V	11.5	24	6.6	25.5	380
DF17#(4.0)-30DP-0.5V	11.5	24	6.6	25.5	380
DF17#(4.0)-40DP-0.5V	11.5	24	6.6	25.5	380

Connector	L	M	N	P	Q	R
DF17#(4.0)-50DP-0.5V	14.2	28.4	32	6.6	33.5	380
DF17#(4.0)-60DP-0.5V	14.2	28.4	32	6.6	33.5	380
DF17#(4.0)-70DP-0.5V	20.2	40.4	44	6.6	45.5	380
DF17#(4.0)-80DP-0.5V	20.2	40.4	44	6.6	45.5	380

Connector	L	M	N	P	Q	R
DF17(1.0H)-26DP-0.5V	11.5	-	24	3.6	25.5	330
DF17(1.0H)-30DP-0.5V	11.5	-	24	3.6	25.5	330
DF17(1.0H)-60DP-0.5V	14.2	28.4	32	3.6	33.5	330
DF17(1.0H)-70DP-0.5V	20.2	40.4	44	3.6	45.5	330
DF17(1.0H)-80DP-0.5V	20.2	40.4	44	3.6	45.5	330

Reel Dimensions

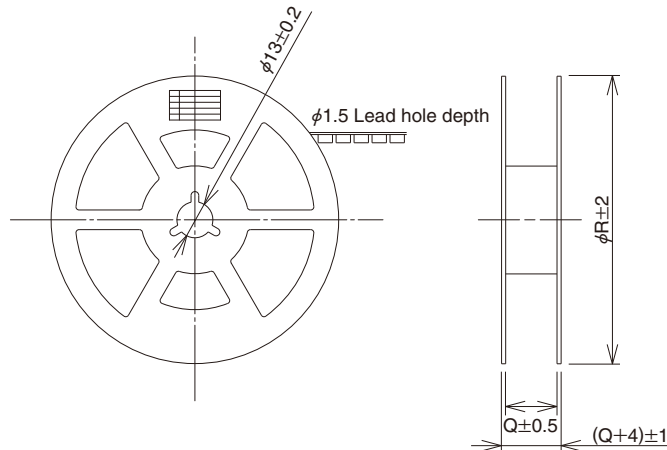

■Precautions

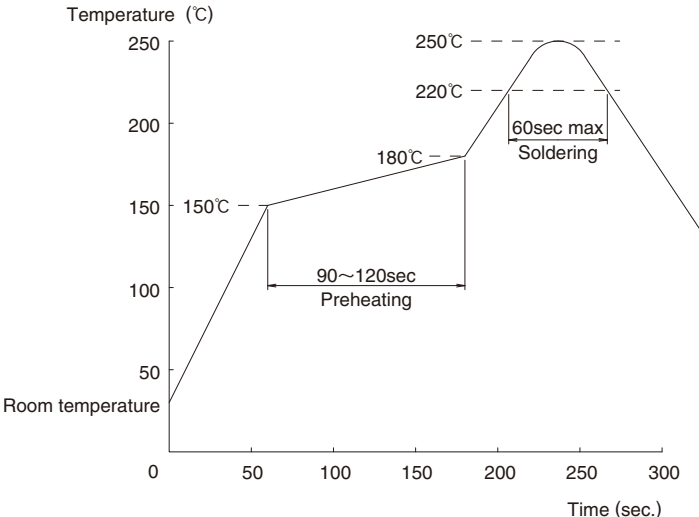
<p>1. Recommended Temperature Profile (SMT)</p>	 <p>Note1 : Up to 2 cycles of Reflow soldering are possible under the same conditions, provided that there is a return to normal temperature between the first and second cycle.</p> <p>Note2 : The temperature profile indicates the board surface temperature at the point of contacts with the connector terminals.</p>
<p>2. Recommended Manual Soldering Condition (SMT)</p>	<p>Soldering iron temperature: $350\pm 3^{\circ}\text{C}$ Soldering time: Within 2 seconds</p>
<p>3. Recommended Screen Thickness (SMT)</p>	<p>0.15mm</p>
<p>4. Board Warp(SMT)</p>	<p>Max 0.02mm in the connector center area, based on the both connector edges</p>
<p>5. Cleaning Condition</p>	<p>Refer to the "Nylon Connector Use Hand book".</p>
<p>6. Cautions</p>	<ul style="list-style-type: none"> ■ The header is designed in a structure where contacts are exposed. Touching it with bare hands would cause contact failure or electrostatic element damage. ■ Where no board is mounted, the insertion or extraction will cause damage or contact deformation. ■ Avoid retaining the board with the connector only, and fix the board by any other means than the connector. ■ Excessive scoop insertion or extraction may result in damage. ■ In the manual soldering process, don't carry out the flux coating which will cause a flux blister on the connector. ■ The color phase of this product may be slightly different from that of the formed product according to the manufacturing lot. However, the difference doesn't affect the performance.

HIROSE ELECTRIC CO.,LTD.

2-6-3,Nakagawa Chuoh,Tsuzuki-Ku,Yokohama-Shi 224-8540,JAPAN
<https://www.hirose.com/>

Looking for pricing, stock, or lifecycle information?

Click below to explore more details on WIN SOURCE:

- [View DF17\(1.0H\)-70DP-0.5V\(57\) on WIN SOURCE](#)
- [Hirose Electric Co Ltd Information](#)

Optimize Your Supply Chain with WIN SOURCE Solutions

- ✓ Global Sourcing Solution
- ✓ Obsolete Management
- ✓ Cost Control Management
- ✓ Shortage Management
- ✓ Alternative Solution
- ✓ Excess Inventory Management