



**THE DATASHEET OF
HIF3BA-14D-2.54R**



TMUX1108 5V / $\pm 2.5V$, Low-Leakage-Current, 8:1 Precision Multiplexer

1 Features

- Wide supply range: $\pm 2.5V$, 1.08V to 5.5V
- Low leakage current: 3pA
- Low charge injection: 1pC
- Low on-resistance: 2.5Ω
- $-40^{\circ}C$ to $+125^{\circ}C$ operating temperature
- [1.8V logic compatible](#)
- [Fail-safe logic](#)
- [Rail to rail operation](#)
- [Bidirectional signal path](#)
- Break-before-make switching action
- ESD protection HBM: 2000V

2 Applications

- [Ultrasound scanners](#)
- [Patient monitoring and diagnostics](#)
- [Optical networking](#)
- [Optical test equipment](#)
- [Remote radio unit](#)
- [ATE test equipment](#)
- [Factory automation and industrial process controls](#)
- [Programmable logic controllers \(PLC\)](#)
- [Analog input modules](#)
- [Digital multimeters](#)
- [Battery monitoring systems](#)

3 Description

The TMUX1108 is a precision complementary metal-oxide semiconductor (CMOS) multiplexer (MUX). The TMUX1108 offers a single channel, 8:1 configuration. A wide operating supply of 1.08V to 5.5V makes this device an excellent choice for a wide array of applications from medical equipment to industrial systems. The device supports bidirectional analog and digital signals on the source (Sx) and drain (D) pins ranging from GND to V_{DD} . All logic inputs have [1.8V logic compatible](#) thresholds, allowing for both TTL and CMOS logic compatibility when operating in the valid supply voltage range. [Fail-Safe Logic](#) circuitry allows voltages on the control pins to be applied before the supply pin, protecting the device from potential damage.

The TMUX1108 is part of the precision switches and multiplexers family of devices. These devices have very low on and off leakage currents and low charge injection, allowing them to be used in high precision measurement applications. A low supply current of 8nA and small package options enable use in portable applications.

Package Information

PART NUMBER ⁽¹⁾	PACKAGE ⁽²⁾	PACKAGE SIZE ⁽³⁾
TMUX1108	PW (TSSOP, 16)	5mm × 6.4mm
	RSV (QFN, 16)	2.6mm × 1.8mm

- (1) See [Device Comparison](#)
- (2) For more information, see [Section 11](#)
- (3) The package size (length × width) is a nominal value and includes pins, where applicable.

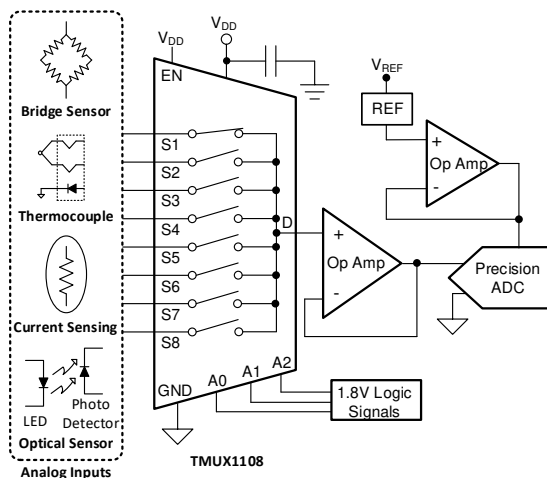

Application Example

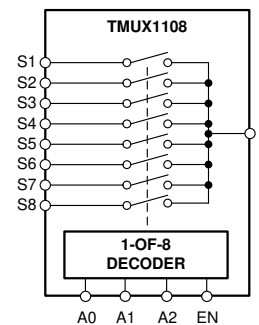

Block Diagram



Table of Contents

1 Features	1	7.2 Functional Block Diagram.....	21
2 Applications	1	7.3 Feature Description.....	21
3 Description	1	7.4 Device Functional Modes.....	23
4 Device Comparison Table	2	8 Application and Implementation	24
5 Pin Configuration and Functions	2	8.1 Application Information.....	24
6 Specifications	4	8.2 Typical Application.....	24
6.1 Absolute Maximum Ratings.....	4	8.3 Power Supply Recommendations.....	25
6.2 ESD Ratings.....	4	8.4 Layout.....	26
6.3 Recommended Operating Conditions.....	4	9 Device and Documentation Support	27
6.4 Thermal Information.....	5	9.1 Documentation Support.....	27
6.5 Electrical Characteristics ($V_{DD} = 5V \pm 10\%$).....	5	9.2 Receiving Notification of Documentation Updates.....	27
6.6 Electrical Characteristics ($V_{DD} = 3.3V \pm 10\%$).....	7	9.3 Support Resources.....	27
6.7 Electrical Characteristics ($V_{DD} = 2.5V \pm 10\%$, $V_{SS} = -2.5V \pm 10\%$).....	8	9.4 Trademarks.....	27
6.8 Electrical Characteristics ($V_{DD} = 1.8V \pm 10\%$).....	9	9.5 Electrostatic Discharge Caution.....	27
6.9 Electrical Characteristics ($V_{DD} = 1.2V \pm 10\%$).....	11	9.6 Glossary.....	27
6.10 Typical Characteristics.....	13	10 Revision History	27
7 Detailed Description	16	11 Mechanical, Packaging, and Orderable Information	28
7.1 Overview.....	16		

4 Device Comparison Table

PRODUCT	DESCRIPTION
TMUX1108	8:1, 1-Channel, single-ended multiplexer

5 Pin Configuration and Functions

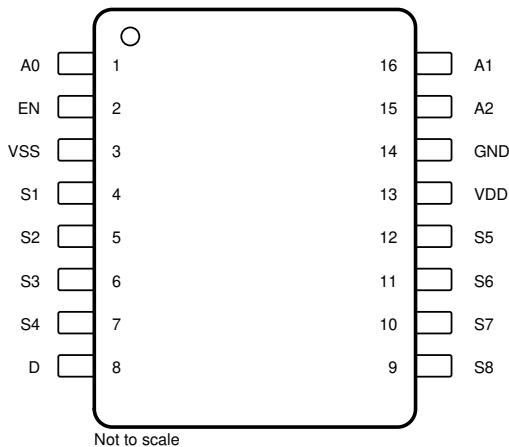

Figure 5-1. TMUX1108: PW Package, 16-Pin TSSOP (Top View)

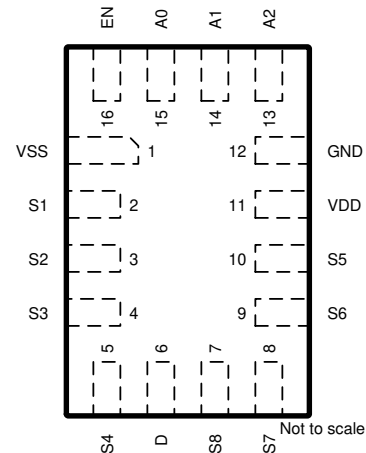

Figure 5-2. TMUX1108: RSV Package, 16-Pin QFN (Top View)

Table 5-1. Pin Functions

PIN			TYPE ⁽¹⁾	DESCRIPTION
NAME	TSSOP	UQFN		
A0	1	15	I	Address line 0
EN	2	16	I	Active high logic input. When this pin is low, all switches are turned off. When this pin is high, the A[2:0] logic inputs determine which switch is turned on.
VSS	3	1	P	Negative power supply. This pin is the most negative power-supply potential. For reliable operation, connect a decoupling capacitor ranging from 0.1µF to 10µF between V _{SS} and GND. V _{SS} can be connected to ground for single supply applications.
S1	4	2	I/O	Source pin 1. Can be an input or output.
S2	5	3	I/O	Source pin 2. Can be an input or output.
S3	6	4	I/O	Source pin 3. Can be an input or output.
S4	7	5	I/O	Source pin 4. Can be an input or output.
D	8	6	I/O	Drain pin. Can be an input or output.
S8	9	7	I/O	Source pin 8. Can be an input or output.
S7	10	8	I/O	Source pin 7. Can be an input or output.
S6	11	9	I/O	Source pin 6. Can be an input or output.
S5	12	10	I/O	Source pin 5. Can be an input or output.
VDD	13	11	P	Positive power supply. This pin is the most positive power-supply potential. For reliable operation, connect a decoupling capacitor ranging from 0.1µF to 10µF between V _{DD} and GND.
GND	14	12	P	Ground (0V) reference
A2	15	13	I	Address line 2
A1	16	14	I	Address line 1

(1) I = input, O = output, I/O = input and output, P = power

6 Specifications

6.1 Absolute Maximum Ratings

over operating free-air temperature range (unless otherwise noted)^{(1) (2) (3)}

		MIN	MAX	UNIT
$V_{DD}-V_{SS}$	Supply voltage	-0.5	6	V
V_{DD}		-0.5	6	V
V_{SS}		-3.0	0.3	V
V_{SEL} or V_{EN}	Logic control input pin voltage (EN, A0, A1, A2)	-0.5	6	V
I_{SEL} or I_{EN}	Logic control input pin current (EN, A0, A1, A2)	-30	30	mA
V_S or V_D	Source or drain voltage (Sx, D)	-0.5	$V_{DD}+0.5$	V
I_S or I_D (CONT)	Source or drain continuous current (Sx, D)	$I_{DC} \pm 10\%$ ⁽⁴⁾	$I_{DC} \pm 10\%$ ⁽⁴⁾	mA
I_S or I_D (PEAK)	Source and drain peak current: (1 ms period maximum, 10% duty cycle maximum) (Sx, SxA, SxB, D, DA, DB)	$I_{peak} \pm 10\%$ ⁽⁴⁾	$I_{peak} \pm 10\%$ ⁽⁴⁾	mA
T_{stg}	Storage temperature	-65	150	°C
P_{tot}	Total power dissipation ^{(5) (6)}		500	mW
T_J	Junction temperature		150	°C

- (1) Stresses beyond those listed under *Absolute Maximum Rating* may cause permanent damage to the device. These are stress ratings only, which do not imply functional operation of the device at these or any other conditions beyond those indicated under *Recommended Operating Condition*. Exposure to absolute-maximum-rated conditions for extended periods may affect device reliability.
- (2) The algebraic convention, whereby the most negative value is a minimum and the most positive value is a maximum.
- (3) All voltages are with respect to ground, unless otherwise specified.
- (4) Refer to Recommended Operating Conditions for I_{DC} and I_{Peak} ratings.
- (5) For TSSOP package: P_{tot} derates linearly above $T_A=90^\circ\text{C}$ by $8.41\text{mW}/^\circ\text{C}$
- (6) For QFN package: P_{tot} derates linearly above $T_A=82^\circ\text{C}$ by $7.43\text{mW}/^\circ\text{C}$

6.2 ESD Ratings

			VALUE	UNIT
$V_{(ESD)}$	Electrostatic discharge	Human body model (HBM), per ANSI/ESDA/ JEDEC JS-001, all pins ⁽¹⁾	±2000	V
		Charged device model (CDM), per JEDEC specification JESD22-C101, all pins ⁽²⁾	±750	

- (1) JEDEC document JEP155 states that 500-V HBM allows safe manufacturing with a standard ESD control process.
- (2) JEDEC document JEP157 states that 250-V CDM allows safe manufacturing with a standard ESD control process.

6.3 Recommended Operating Conditions

over operating free-air temperature range (unless otherwise noted)

			MIN	NOM	MAX	UNIT
V_{DD}	Positive power supply voltage (single)		1.08		5.5	V
V_{SS}	Negative power supply voltage (dual)		-2.75		0	V
$V_{DD} - V_{SS}$	Supply rail voltage difference		1.08		5.5	V
V_S or V_D	Signal path input/output voltage (source or drain pin) (Sx, D)		V_{SS}		V_{DD}	V
V_{SEL} or V_{EN}	Address or enable pin voltage		0		5.5	V
T_A	Ambient temperature		-40		125	°C
I_{DC}	Continuous current through switch	$T_J = 25^\circ\text{C}$		150		mA
		$T_J = 85^\circ\text{C}$		120		mA
		$T_J = 125^\circ\text{C}$		60		mA
		$T_J = 130^\circ\text{C}$		50		mA

6.3 Recommended Operating Conditions (continued)

over operating free-air temperature range (unless otherwise noted)

			MIN	NOM	MAX	UNIT
I_{peak}	Peak current through switch(1 ms period maximum, 10% duty cycle maximum)	$T_j = 25^\circ\text{C}$		300		mA
		$T_j = 85^\circ\text{C}$		300		mA
		$T_j = 125^\circ\text{C}$		180		mA
		$T_j = 130^\circ\text{C}$		160		mA

6.4 Thermal Information

THERMAL METRIC ⁽¹⁾		DEVICE	DEVICE	UNIT
		PW (TSSOP)	RSV (QFN)	
		16 PINS	16 PINS	
$R_{\theta JA}$	Junction-to-ambient thermal resistance	118.9	134.6	$^\circ\text{C}/\text{W}$
$R_{\theta JC(top)}$	Junction-to-case (top) thermal resistance	49.3	74.3	$^\circ\text{C}/\text{W}$
$R_{\theta JB}$	Junction-to-board thermal resistance	65.2	62.8	$^\circ\text{C}/\text{W}$
Ψ_{JT}	Junction-to-top characterization parameter	7.6	4.3	$^\circ\text{C}/\text{W}$
Ψ_{JB}	Junction-to-board characterization parameter	64.6	61.1	$^\circ\text{C}/\text{W}$
$R_{\theta JC(bot)}$	Junction-to-case (bottom) thermal resistance	N/A	N/A	$^\circ\text{C}/\text{W}$

(1) For more information about traditional and new thermal metrics, see the [Semiconductor and IC Package Thermal Metrics](#) application report.

6.5 Electrical Characteristics ($V_{DD} = 5V \pm 10\%$)

at $T_A = 25^\circ\text{C}$, $V_{DD} = 5V$ (unless otherwise noted)

PARAMETER		TEST CONDITIONS	TA	MIN	TYP	MAX	UNIT
ANALOG SWITCH							
R_{ON}	On-resistance	$V_S = 0V$ to V_{DD} $I_{SD} = 10\text{mA}$	25°C		2.5	4	Ω
			-40°C to $+85^\circ\text{C}$			4.5	Ω
			-40°C to $+125^\circ\text{C}$			4.9	Ω
ΔR_{ON}	On-resistance matching between channels	$V_S = 0V$ to V_{DD} $I_{SD} = 10\text{mA}$	25°C		0.13		Ω
			-40°C to $+85^\circ\text{C}$			0.4	Ω
			-40°C to $+125^\circ\text{C}$			0.5	Ω
$R_{ON FLAT}$	On-resistance flatness	$V_S = 0V$ to V_{DD} $I_{SD} = 10\text{mA}$	25°C		0.85		Ω
			-40°C to $+85^\circ\text{C}$			1.6	Ω
			-40°C to $+125^\circ\text{C}$			1.6	Ω
$I_{S(OFF)}$	Source off leakage current ⁽¹⁾	$V_{DD} = 5V$ Switch Off $V_D = 4.5V / 1.5V$ $V_S = 1.5V / 4.5V$	25°C	-0.08	± 0.005	0.08	nA
			-40°C to $+85^\circ\text{C}$	-0.3		0.3	nA
			-40°C to $+125^\circ\text{C}$	-0.9		0.9	nA
$I_{D(OFF)}$	Drain off leakage current ⁽¹⁾	$V_{DD} = 5V$ Switch Off $V_D = 4.5V / 1.5V$ $V_S = 1.5V / 4.5V$	25°C	-0.1	± 0.01	0.1	nA
			-40°C to $+85^\circ\text{C}$	-1		1	nA
			-40°C to $+125^\circ\text{C}$	-5.5		5.5	nA
$I_{D(ON)}$ $I_{S(ON)}$	Channel on leakage current	$V_{DD} = 5V$ Switch On $V_D = V_S = 2.5V$	25°C	-0.025	± 0.003	0.025	nA
			-40°C to $+85^\circ\text{C}$	-0.5		0.5	nA
			-40°C to $+125^\circ\text{C}$	-0.95		0.95	nA
$I_{D(ON)}$ $I_{S(ON)}$	Channel on leakage current	$V_{DD} = 5V$ Switch On $V_D = V_S = 4.5V / 1.5V$	25°C	-0.1	± 0.01	0.1	nA
			-40°C to $+85^\circ\text{C}$	-0.75		0.75	nA
			-40°C to $+125^\circ\text{C}$	-4		4	nA

6.5 Electrical Characteristics (V_{DD} = 5V ±10 %) (continued)

at T_A = 25°C, V_{DD} = 5V (unless otherwise noted)

PARAMETER		TEST CONDITIONS	TA	MIN	TYP	MAX	UNIT
LOGIC INPUTS (EN, A0, A1, A2)							
V _{IH}	Input logic high		–40°C to +125°C	1.49		5.5	V
V _{IL}	Input logic low		–40°C to +125°C	0		0.87	V
I _{IH} I _{IL}	Input leakage current		25°C		±0.005		µA
I _{IH} I _{IL}	Input leakage current		–40°C to +125°C			±0.05	µA
C _{IN}	Logic input capacitance		25°C		1		pF
C _{IN}	Logic input capacitance		–40°C to +125°C			2	pF
POWER SUPPLY							
I _{DD}	V _{DD} supply current	Logic inputs = 0V or 5.5V	25°C		0.008		µA
			–40°C to +125°C			1	µA
DYNAMIC CHARACTERISTICS							
t _{TRAN}	Transition time between channels	V _S = 3V R _L = 200Ω, C _L = 15pF	25°C		14		ns
			–40°C to +85°C			18	ns
			–40°C to +125°C			19	ns
t _{OPEN} (BBM)	Break before make time	V _S = 3V R _L = 200Ω, C _L = 15pF	25°C		8		ns
			–40°C to +85°C	1			ns
			–40°C to +125°C	1			ns
t _{ON(EN)}	Enable turn-on time	V _S = 3V R _L = 200Ω, C _L = 15pF	25°C		12		ns
			–40°C to +85°C			19	ns
			–40°C to +125°C			20	ns
t _{OFF(EN)}	Enable turn-off time	V _S = 3V R _L = 200Ω, C _L = 15pF	25°C		6		ns
			–40°C to +85°C			8	ns
			–40°C to +125°C			9	ns
Q _C	Charge Injection	V _S = 1V R _S = 0Ω, C _L = 1nF	25°C		–1		pC
O _{ISO}	Off Isolation	R _L = 50Ω, C _L = 5pF f = 1MHz	25°C		–65		dB
		R _L = 50Ω, C _L = 5pF f = 10MHz	25°C		–45		dB
X _{TALK}	Crosstalk	R _L = 50Ω, C _L = 5pF f = 1MHz	25°C		–65		dB
		R _L = 50Ω, C _L = 5pF f = 10MHz	25°C		–45		dB
BW	Bandwidth	R _L = 50Ω, C _L = 5pF	25°C		90		MHz
C _{SOFF}	Source off capacitance	f = 1MHz	25°C		7		pF
C _{DOFF}	Drain off capacitance	f = 1MHz	25°C		60		pF
C _{SON} C _{DON}	On capacitance	f = 1MHz	25°C		65		pF

(1) When V_S is 4.5V, V_D is 1.5V, and vice versa.

6.6 Electrical Characteristics ($V_{DD} = 3.3V \pm 10\%$)

at $T_A = 25^\circ\text{C}$, $V_{DD} = 3.3V$ (unless otherwise noted)

PARAMETER		TEST CONDITIONS	TA	MIN	TYP	MAX	UNIT
ANALOG SWITCH							
R_{ON}	On-resistance	$V_S = 0V$ to V_{DD} $I_{SD} = 10\text{mA}$	25°C		4	8.75	Ω
			-40°C to +85°C			9.5	Ω
			-40°C to +125°C			9.75	Ω
ΔR_{ON}	On-resistance matching between channels	$V_S = 0V$ to V_{DD} $I_{SD} = 10\text{mA}$	25°C		0.13		Ω
			-40°C to +85°C			0.4	Ω
			-40°C to +125°C			0.5	Ω
R_{ON} $FLAT$	On-resistance flatness	$V_S = 0V$ to V_{DD} $I_{SD} = 10\text{mA}$	25°C		1.9		Ω
			-40°C to +85°C			2	Ω
			-40°C to +125°C			2.2	Ω
$I_{S(OFF)}$	Source off leakage current	$V_{DD} = 3.3V$ Switch Off $V_D = 3V / 1V$ $V_S = 1V / 3V$	25°C	-0.05	± 0.001	0.05	nA
			-40°C to +85°C			0.1	nA
			-40°C to +125°C			0.5	nA
$I_{D(OFF)}$	Drain off leakage current	$V_{DD} = 3.3V$ Switch Off $V_D = 3V / 1V$ $V_S = 1V / 3V$	25°C	-0.1	± 0.005	0.1	nA
			-40°C to +85°C			0.5	nA
			-40°C to +125°C			1.5	nA
$I_{D(ON)}$ $I_{S(ON)}$	Channel on leakage current	$V_{DD} = 3.3V$ Switch On $V_D = V_S = 3V / 1V$	25°C	-0.1	± 0.005	0.1	nA
			-40°C to +85°C			0.5	nA
			-40°C to +125°C			1.5	nA
LOGIC INPUTS (EN, A0, A1, A2)							
V_{IH}	Input logic high		-40°C to +125°C	1.35		5.5	V
V_{IL}	Input logic low		-40°C to +125°C	0		0.8	V
I_{IH} I_{IL}	Input leakage current		25°C		± 0.005		μA
			-40°C to +125°C			± 0.05	μA
C_{IN}	Logic input capacitance		25°C		1		pF
C_{IN}	Logic input capacitance		-40°C to +125°C			2	pF
POWER SUPPLY							
I_{DD}	V_{DD} supply current	Logic inputs = 0V or 5.5V	25°C		0.006		μA
			-40°C to +125°C			1	μA
DYNAMIC CHARACTERISTICS							
t_{TRAN}	Transition time between channels	$V_S = 2V$ $R_L = 200\Omega$, $C_L = 15\text{pF}$	25°C		15		ns
			-40°C to +85°C			23	ns
			-40°C to +125°C			23	ns
t_{OPEN} (BBM)	Break before make time	$V_S = 2V$ $R_L = 200\Omega$, $C_L = 15\text{pF}$	25°C		8		ns
			-40°C to +85°C		1		ns
			-40°C to +125°C		1		ns
$t_{ON(EN)}$	Enable turn-on time	$V_S = 2V$ $R_L = 200\Omega$, $C_L = 15\text{pF}$	25°C		14		ns
			-40°C to +85°C			25	ns
			-40°C to +125°C			25	ns
$t_{OFF(EN)}$	Enable turn-off time	$V_S = 2V$ $R_L = 200\Omega$, $C_L = 15\text{pF}$	25°C		7		ns
			-40°C to +85°C			12	ns
			-40°C to +125°C			12	ns

6.6 Electrical Characteristics ($V_{DD} = 3.3V \pm 10\%$) (continued)

 at $T_A = 25^\circ C$, $V_{DD} = 3.3V$ (unless otherwise noted)

PARAMETER		TEST CONDITIONS	TA	MIN	TYP	MAX	UNIT
Q_C	Charge Injection	$V_S = 1V$ $R_S = 0\Omega$, $C_L = 1nF$	$25^\circ C$		-2		pC
O_{ISO}	Off Isolation	$R_L = 50\Omega$, $C_L = 5pF$ $f = 1MHz$	$25^\circ C$		-65		dB
		$R_L = 50\Omega$, $C_L = 5pF$ $f = 10MHz$	$25^\circ C$		-45		dB
X_{TALK}	Crosstalk	$R_L = 50\Omega$, $C_L = 5pF$ $f = 1MHz$	$25^\circ C$		-65		dB
		$R_L = 50\Omega$, $C_L = 5pF$ $f = 10MHz$	$25^\circ C$		-45		dB
BW	Bandwidth	$R_L = 50\Omega$, $C_L = 5pF$	$25^\circ C$		90		MHz
C_{SOFF}	Source off capacitance	$f = 1MHz$	$25^\circ C$		7		pF
C_{DOFF}	Drain off capacitance	$f = 1MHz$	$25^\circ C$		60		pF
C_{SON} C_{DON}	On capacitance	$f = 1MHz$	$25^\circ C$		65		pF

6.7 Electrical Characteristics ($V_{DD} = 2.5V \pm 10\%$), ($V_{SS} = -2.5V \pm 10\%$)

 at $T_A = 25^\circ C$, $V_{DD} = +2.5V$, $V_{SS} = -2.5V$ (unless otherwise noted)

PARAMETER		TEST CONDITIONS	TA	MIN	TYP	MAX	UNIT	
ANALOG SWITCH								
R_{ON}	On-resistance	$V_S = V_{SS}$ to V_{DD} $I_{SD} = 10mA$	$25^\circ C$		2.5	4	Ω	
			$-40^\circ C$ to $+85^\circ C$			4.5	Ω	
			$-40^\circ C$ to $+125^\circ C$			4.9	Ω	
ΔR_{ON}	On-resistance matching between channels	$V_S = V_{SS}$ to V_{DD} $I_{SD} = 10mA$	$25^\circ C$		0.13		Ω	
			$-40^\circ C$ to $+85^\circ C$			0.4	Ω	
			$-40^\circ C$ to $+125^\circ C$			0.5	Ω	
R_{ON} FLAT	On-resistance flatness	$V_S = V_{SS}$ to V_{DD} $I_{SD} = 10mA$	$25^\circ C$		0.85		Ω	
			$-40^\circ C$ to $+85^\circ C$			1.6	Ω	
			$-40^\circ C$ to $+125^\circ C$			1.6	Ω	
$I_{S(OFF)}$	Source off leakage current	$V_{DD} = +2.5V$, $V_{SS} = -2.5V$ Switch Off $V_D = +2V / -1V$ $V_S = -1V / +2V$	$25^\circ C$	-0.08	± 0.005	0.08	nA	
			$-40^\circ C$ to $+85^\circ C$		-0.3		0.3	nA
			$-40^\circ C$ to $+125^\circ C$		-0.9		0.9	nA
$I_{D(OFF)}$	Drain off leakage current	$V_{DD} = +2.5V$, $V_{SS} = -2.5V$ Switch Off $V_D = +2V / -1V$ $V_S = -1V / +2V$	$25^\circ C$	-0.1	± 0.01	0.1	nA	
			$-40^\circ C$ to $+85^\circ C$		-1		1	nA
			$-40^\circ C$ to $+125^\circ C$		-5.5		5.5	nA
$I_{D(ON)}$ $I_{S(ON)}$	Channel on leakage current	$V_{DD} = +2.5V$, $V_{SS} = -2.5V$ Switch On $V_D = V_S = +2V / -1V$	$25^\circ C$	-0.1	± 0.01	0.1	nA	
			$-40^\circ C$ to $+85^\circ C$		-0.75		0.75	nA
			$-40^\circ C$ to $+125^\circ C$		-4		4	nA
LOGIC INPUTS (EN, A0, A1, A2)								
V_{IH}	Input logic high		$-40^\circ C$ to $+125^\circ C$	1.2		2.75	V	
V_{IL}	Input logic low		$-40^\circ C$ to $+125^\circ C$	0		0.73	V	
I_{IH} I_{IL}	Input leakage current		$25^\circ C$		± 0.005		μA	
I_{IH} I_{IL}	Input leakage current		$-40^\circ C$ to $+125^\circ C$			± 0.05	μA	
C_{IN}	Logic input capacitance		$25^\circ C$		1		pF	

6.7 Electrical Characteristics ($V_{DD} = 2.5V \pm 10\%$), ($V_{SS} = -2.5V \pm 10\%$) (continued)

at $T_A = 25^\circ\text{C}$, $V_{DD} = +2.5V$, $V_{SS} = -2.5V$ (unless otherwise noted)

PARAMETER		TEST CONDITIONS	TA	MIN	TYP	MAX	UNIT
C_{IN}	Logic input capacitance		-40°C to $+125^\circ\text{C}$			2	pF
POWER SUPPLY							
I_{DD}	V_{DD} supply current	Logic inputs = 0V or 2.75V	25°C		0.008		μA
			-40°C to $+125^\circ\text{C}$			1	μA
I_{SS}	V_{SS} supply current	Logic inputs = 0V or 2.75V	25°C		0.008		μA
			-40°C to $+125^\circ\text{C}$			1	μA
DYNAMIC CHARACTERISTICS							
t_{TRAN}	Transition time between channels	$V_S = 1.5V$ $R_L = 200\Omega$, $C_L = 15\text{pF}$	25°C		14		ns
			-40°C to $+85^\circ\text{C}$			21	ns
			-40°C to $+125^\circ\text{C}$			21	ns
t_{OPEN} (BBM)	Break before make time	$V_S = 1.5V$ $R_L = 200\Omega$, $C_L = 15\text{pF}$	25°C		8		ns
			-40°C to $+85^\circ\text{C}$		1		ns
			-40°C to $+125^\circ\text{C}$		1		ns
$t_{ON(EN)}$	Enable turn-on time	$V_S = 1.5V$ $R_L = 200\Omega$, $C_L = 15\text{pF}$	25°C		13		ns
			-40°C to $+85^\circ\text{C}$			21	ns
			-40°C to $+125^\circ\text{C}$			21	ns
$t_{OFF(EN)}$	Enable turn-off time	$V_S = 1.5V$ $R_L = 200\Omega$, $C_L = 15\text{pF}$	25°C		8		ns
			-40°C to $+85^\circ\text{C}$			11	ns
			-40°C to $+125^\circ\text{C}$			12	ns
Q_C	Charge Injection	$V_S = -1V$ $R_S = 0\Omega$, $C_L = 1\text{nF}$	25°C		-2.5		pC
O_{ISO}	Off Isolation	$R_L = 50\Omega$, $C_L = 5\text{pF}$ $f = 1\text{MHz}$	25°C		-65		dB
		$R_L = 50\Omega$, $C_L = 5\text{pF}$ $f = 10\text{MHz}$	25°C		-45		dB
X_{TALK}	Crosstalk	$R_L = 50\Omega$, $C_L = 5\text{pF}$ $f = 1\text{MHz}$	25°C		-65		dB
		$R_L = 50\Omega$, $C_L = 5\text{pF}$ $f = 10\text{MHz}$	25°C		-45		dB
BW	Bandwidth	$R_L = 50\Omega$, $C_L = 5\text{pF}$	25°C		85		MHz
C_{SOFF}	Source off capacitance	$f = 1\text{MHz}$	25°C		7		pF
C_{DOFF}	Drain off capacitance	$f = 1\text{MHz}$	25°C		60		pF
C_{SON} C_{DON}	On capacitance	$f = 1\text{MHz}$	25°C		65		pF

6.8 Electrical Characteristics ($V_{DD} = 1.8V \pm 10\%$)

at $T_A = 25^\circ\text{C}$, $V_{DD} = 1.8V$ (unless otherwise noted)

PARAMETER		TEST CONDITIONS	TA	MIN	TYP	MAX	UNIT
ANALOG SWITCH							
R_{ON}	On-resistance	$V_S = 0V$ to V_{DD} $I_{SD} = 10\text{mA}$	25°C		40		Ω
			-40°C to $+85^\circ\text{C}$			80	Ω
			-40°C to $+125^\circ\text{C}$			80	Ω
ΔR_{ON}	On-resistance matching between channels	$V_S = 0V$ to V_{DD} $I_{SD} = 10\text{mA}$	25°C		0.3		Ω
			-40°C to $+85^\circ\text{C}$			1.5	Ω
			-40°C to $+125^\circ\text{C}$			1.5	Ω

6.8 Electrical Characteristics ($V_{DD} = 1.8V \pm 10\%$) (continued)

at $T_A = 25^\circ\text{C}$, $V_{DD} = 1.8V$ (unless otherwise noted)

PARAMETER		TEST CONDITIONS	TA	MIN	TYP	MAX	UNIT
$I_{S(OFF)}$	Source off leakage current	$V_{DD} = 1.98V$ Switch Off $V_D = 1.62V / 1V$ $V_S = 1V / 1.62V$	25°C	-0.05	±0.003	0.05	nA
			-40°C to +85°C	-0.1		0.1	nA
			-40°C to +125°C	-0.5		0.5	nA
$I_{D(OFF)}$	Drain off leakage current	$V_{DD} = 1.98V$ Switch Off $V_D = 1.62V / 1V$ $V_S = 1V / 1.62V$	25°C	-0.1	±0.005	0.1	nA
			-40°C to +85°C	-0.3		0.3	nA
			-40°C to +125°C	-1.5		1.5	nA
$I_{D(ON)}$ $I_{S(ON)}$	Channel on leakage current	$V_{DD} = 1.98V$ Switch On $V_D = V_S = 1.62V / 1V$	25°C	-0.1	±0.003	0.1	nA
			-40°C to +85°C	-0.5		0.5	nA
			-40°C to +125°C	-2		2	nA
LOGIC INPUTS (EN, A0, A1, A2)							
V_{IH}	Input logic high		-40°C to +125°C	1.07		5.5	V
V_{IL}	Input logic low		-40°C to +125°C	0		0.68	V
I_{IH} I_{IL}	Input leakage current		25°C	±0.005			µA
			-40°C to +125°C			±0.05	µA
C_{IN}	Logic input capacitance		25°C	1			pF
C_{IN}	Logic input capacitance		-40°C to +125°C			2	pF
POWER SUPPLY							
I_{DD}	V_{DD} supply current	Logic inputs = 0V or 5.5V	25°C	0.001			µA
			-40°C to +125°C			0.85	µA
DYNAMIC CHARACTERISTICS							
t_{TRAN}	Transition time between channels	$V_S = 1V$ $R_L = 200\Omega$, $C_L = 15pF$	25°C	28			ns
			-40°C to +85°C			48	ns
			-40°C to +125°C			48	ns
t_{OPEN} (BBM)	Break before make time	$V_S = 1V$ $R_L = 200\Omega$, $C_L = 15pF$	25°C	16			ns
			-40°C to +85°C	1			ns
			-40°C to +125°C	1			ns
$t_{ON(EN)}$	Enable turn-on time	$V_S = 1V$ $R_L = 200\Omega$, $C_L = 15pF$	25°C	28			ns
			-40°C to +85°C			48	ns
			-40°C to +125°C			48	ns
$t_{OFF(EN)}$	Enable turn-off time	$V_S = 1V$ $R_L = 200\Omega$, $C_L = 15pF$	25°C	16			ns
			-40°C to +85°C			27	ns
			-40°C to +125°C			27	ns
Q_C	Charge Injection	$V_S = 1V$ $R_S = 0\Omega$, $C_L = 1nF$	25°C	-0.5			pC
O_{ISO}	Off Isolation	$R_L = 50\Omega$, $C_L = 5pF$ $f = 1MHz$	25°C	-65			dB
		$R_L = 50\Omega$, $C_L = 5pF$ $f = 10MHz$	25°C	-45			dB
X_{TALK}	Crosstalk	$R_L = 50\Omega$, $C_L = 5pF$ $f = 1MHz$	25°C	-65			dB
		$R_L = 50\Omega$, $C_L = 5pF$ $f = 10MHz$	25°C	-45			dB
BW	Bandwidth	$R_L = 50\Omega$, $C_L = 5pF$	25°C	80			MHz
C_{SOFF}	Source off capacitance	$f = 1MHz$	25°C	7			pF

6.8 Electrical Characteristics ($V_{DD} = 1.8V \pm 10\%$) (continued)

at $T_A = 25^\circ\text{C}$, $V_{DD} = 1.8V$ (unless otherwise noted)

PARAMETER		TEST CONDITIONS	TA	MIN	TYP	MAX	UNIT
C_{DOFF}	Drain off capacitance	$f = 1\text{MHz}$	25°C		65		pF
C_{SON} C_{DON}	On capacitance	$f = 1\text{MHz}$	25°C		70		pF

6.9 Electrical Characteristics ($V_{DD} = 1.2V \pm 10\%$)

PARAMETER		TEST CONDITIONS	TA	MIN	TYP	MAX	UNIT
ANALOG SWITCH							
R_{ON}	On-resistance	$V_S = 0V$ to V_{DD} $I_{SD} = 10\text{mA}$	25°C		70		Ω
			-40°C to $+85^\circ\text{C}$			105	Ω
			-40°C to $+125^\circ\text{C}$			105	Ω
ΔR_{ON}	On-resistance matching between channels	$V_S = 0V$ to V_{DD} $I_{SD} = 10\text{mA}$	25°C		0.15		Ω
			-40°C to $+85^\circ\text{C}$			1.5	Ω
			-40°C to $+125^\circ\text{C}$			1.5	Ω
$I_{S(OFF)}$	Source off leakage current ⁽¹⁾	$V_{DD} = 1.32V$ Switch Off $V_D = 1V / 0.8V$ $V_S = 0.8V / 1V$	25°C	-0.05	± 0.003	0.05	nA
			-40°C to $+85^\circ\text{C}$	-0.1		0.1	nA
			-40°C to $+125^\circ\text{C}$	-0.5		0.5	nA
$I_{D(OFF)}$	Drain off leakage current ⁽¹⁾	$V_{DD} = 1.32V$ Switch Off $V_D = 1V / 0.8V$ $V_S = 0.8V / 1V$	25°C	-0.1	± 0.003	0.1	nA
			-40°C to $+85^\circ\text{C}$	-0.3		0.3	nA
			-40°C to $+125^\circ\text{C}$	-1.5		1.5	nA
$I_{D(ON)}$ $I_{S(ON)}$	Channel on leakage current	$V_{DD} = 1.32V$ Switch On $V_D = V_S = 1V / 0.8V$	25°C	-0.1	± 0.003	0.1	nA
			-40°C to $+85^\circ\text{C}$	-0.3		0.3	nA
			-40°C to $+125^\circ\text{C}$	-1.5		1.5	nA
LOGIC INPUTS (EN, A0, A1, A2)							
V_{IH}	Input logic high		-40°C to $+125^\circ\text{C}$	0.96		5.5	V
V_{IL}	Input logic low		-40°C to $+125^\circ\text{C}$	0		0.36	V
I_{IH} I_{IL}	Input leakage current		25°C		± 0.005		μA
			-40°C to $+125^\circ\text{C}$			± 0.05	μA
C_{IN}	Logic input capacitance		25°C		1		pF
C_{IN}	Logic input capacitance		-40°C to $+125^\circ\text{C}$			2	pF
POWER SUPPLY							
I_{DD}	V_{DD} supply current	Logic inputs = 0V or 5.5V	25°C		0.001		μA
			-40°C to $+125^\circ\text{C}$			0.7	μA
DYNAMIC CHARACTERISTICS							
t_{TRAN}	Transition time between channels	$V_S = 1V$ $R_L = 200\Omega$, $C_L = 15\text{pF}$	25°C		60		ns
			-40°C to $+85^\circ\text{C}$			210	ns
			-40°C to $+125^\circ\text{C}$			210	ns
t_{OPEN} (BBM)	Break before make time	$V_S = 1V$ $R_L = 200\Omega$, $C_L = 15\text{pF}$	25°C		28		ns
			-40°C to $+85^\circ\text{C}$		1		ns
			-40°C to $+125^\circ\text{C}$		1		ns
$t_{ON(EN)}$	Enable turn-on time	$V_S = 1V$ $R_L = 200\Omega$, $C_L = 15\text{pF}$	25°C		60		ns
			-40°C to $+85^\circ\text{C}$			190	ns
			-40°C to $+125^\circ\text{C}$			190	ns

6.9 Electrical Characteristics ($V_{DD} = 1.2V \pm 10\%$) (continued)

PARAMETER		TEST CONDITIONS	TA	MIN	TYP	MAX	UNIT
$t_{OFF(EN)}$	Enable turn-off time	$V_S = 1V$ $R_L = 200\Omega, C_L = 15pF$	25°C		45		ns
			-40°C to +85°C			150	ns
			-40°C to +125°C			150	ns
Q_C	Charge Injection	$V_S = 1V$ $R_S = 0\Omega, C_L = 1nF$	25°C		-0.5		pC
O_{ISO}	Off Isolation	$R_L = 50\Omega, C_L = 5pF$ $f = 1MHz$	25°C		-65		dB
		$R_L = 50\Omega, C_L = 5pF$ $f = 10MHz$	25°C		-45		dB
X_{TALK}	Crosstalk	$R_L = 50\Omega, C_L = 5pF$ $f = 1MHz$	25°C		-65		dB
		$R_L = 50\Omega, C_L = 5pF$ $f = 10MHz$	25°C		-45		dB
BW	Bandwidth	$R_L = 50\Omega, C_L = 5pF$	25°C		80		MHz
C_{SOFF}	Source off capacitance	$f = 1MHz$	25°C		7		pF
C_{DOFF}	Drain off capacitance	$f = 1MHz$	25°C		65		pF
C_{SON} C_{DON}	On capacitance	$f = 1MHz$	25°C		70		pF

(1) When V_S is 1V, V_D is 0.8V, and vice versa.

6.10 Typical Characteristics

at $T_A = 25^\circ\text{C}$, $V_{DD} = 5\text{V}$ (unless otherwise noted)

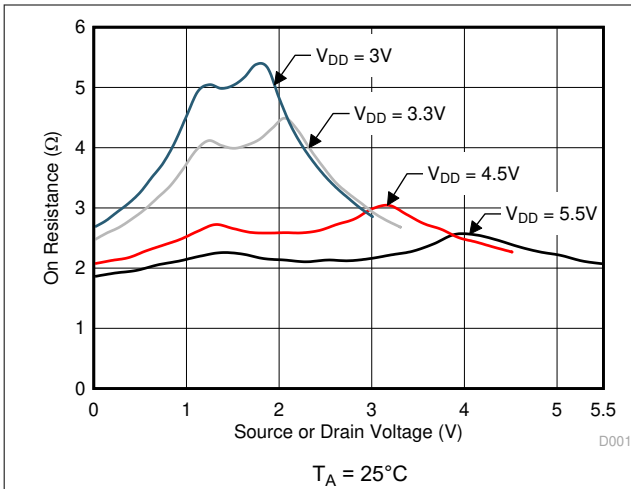

Figure 6-1. On-Resistance vs Source or Drain Voltage

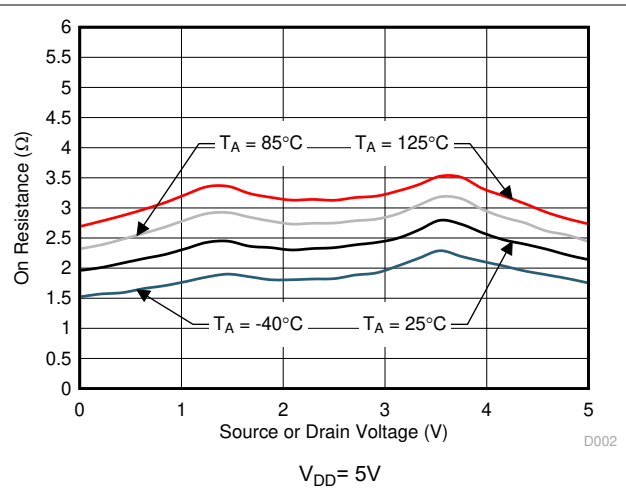

Figure 6-2. On-Resistance vs Temperature

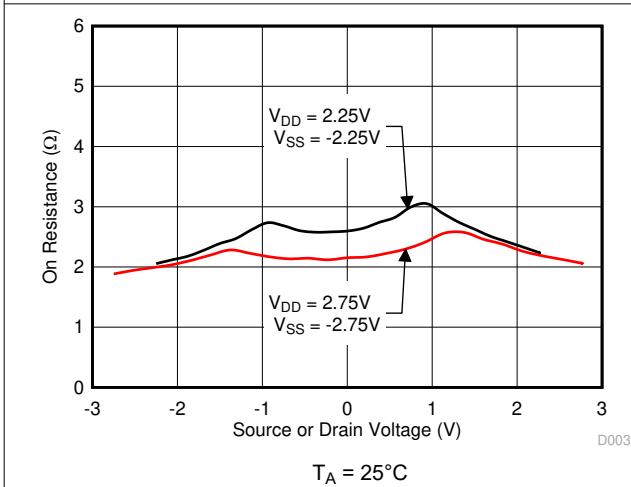

Figure 6-3. On-Resistance vs Source or Drain Voltage

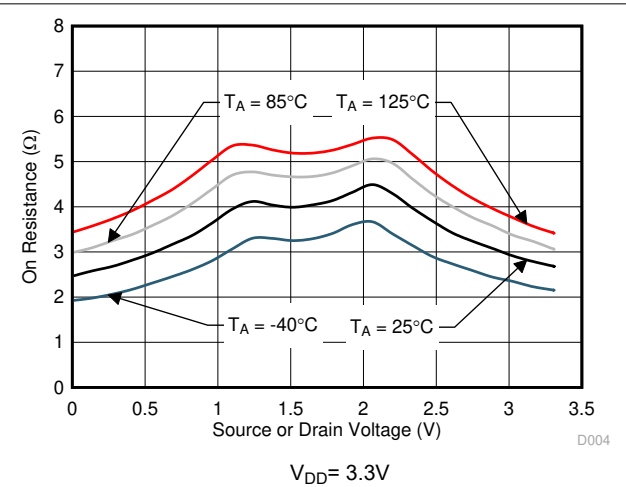

Figure 6-4. On-Resistance vs Temperature

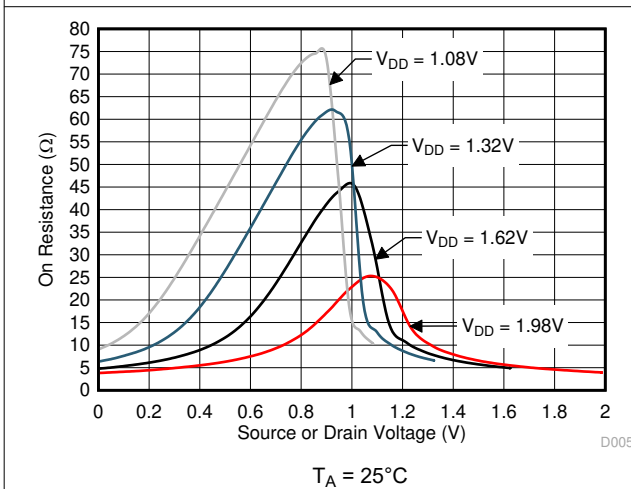

Figure 6-5. On-Resistance vs Source or Drain Voltage

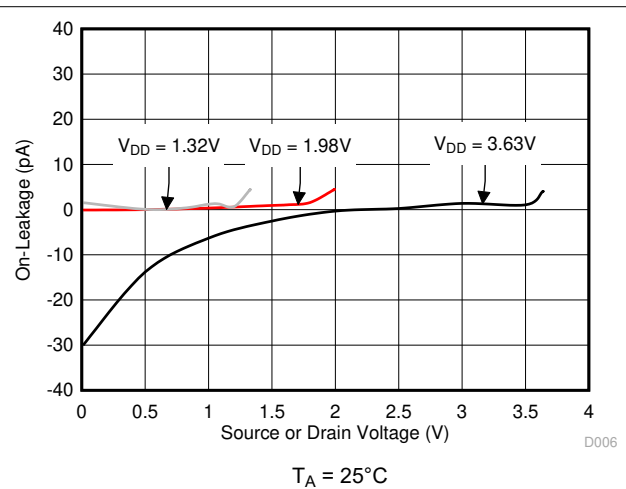

Figure 6-6. On-Leakage vs Source or Drain Voltage

6.10 Typical Characteristics (continued)

at $T_A = 25^\circ\text{C}$, $V_{DD} = 5\text{V}$ (unless otherwise noted)

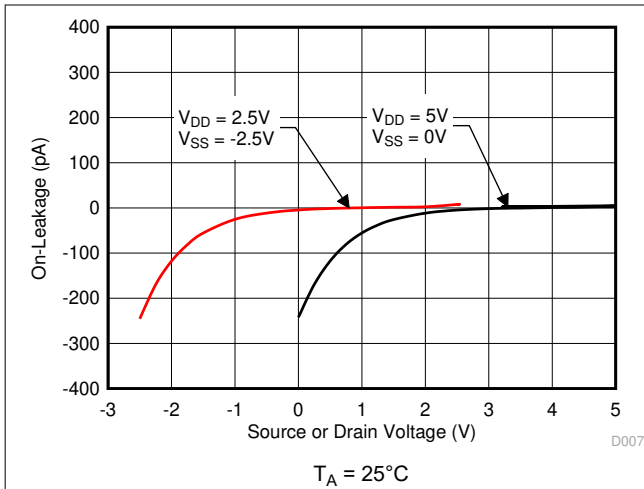

Figure 6-7. On-Leakage vs Source or Drain Voltage

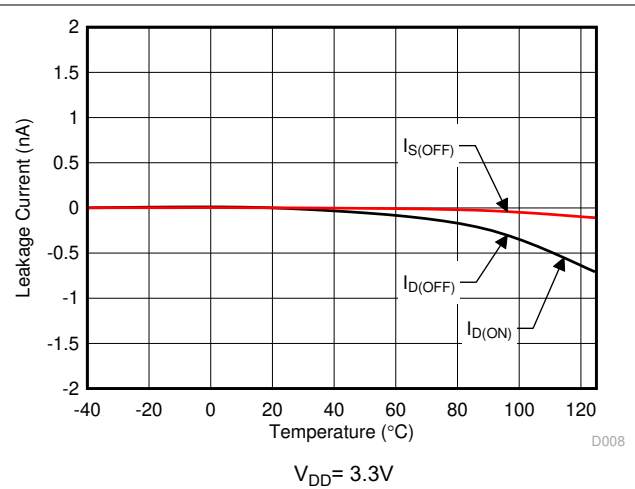

Figure 6-8. Leakage Current vs Temperature

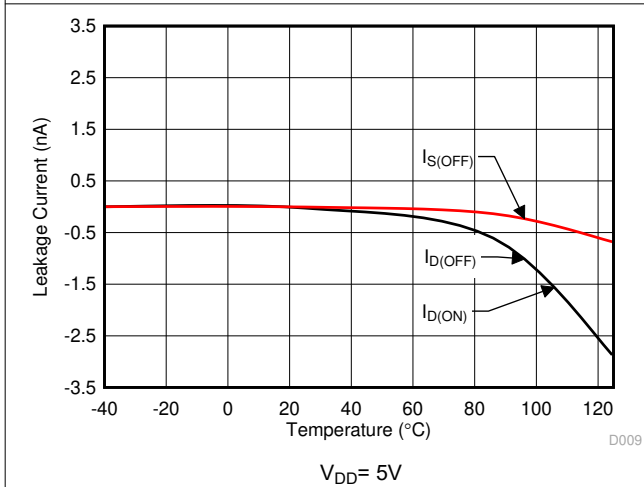

Figure 6-9. Leakage Current vs Temperature

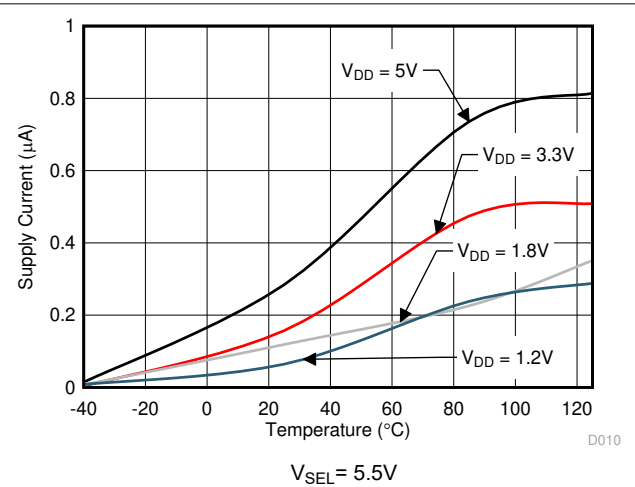

Figure 6-10. Supply Current vs Temperature

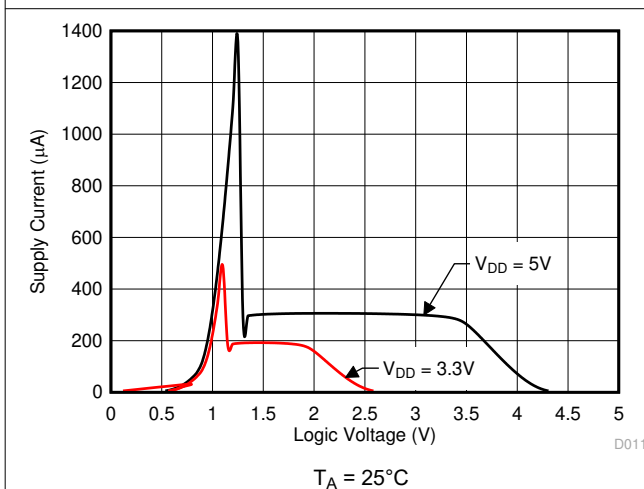

Figure 6-11. Supply Current vs Logic Voltage

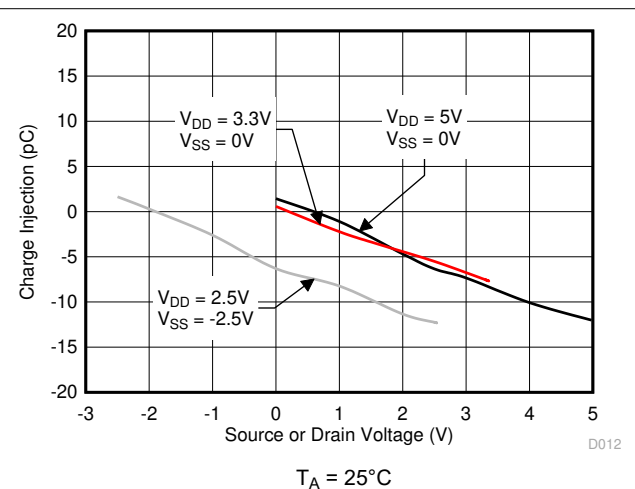

Figure 6-12. Charge Injection vs Source or Drain Voltage

6.10 Typical Characteristics (continued)

at $T_A = 25^\circ\text{C}$, $V_{DD} = 5\text{V}$ (unless otherwise noted)

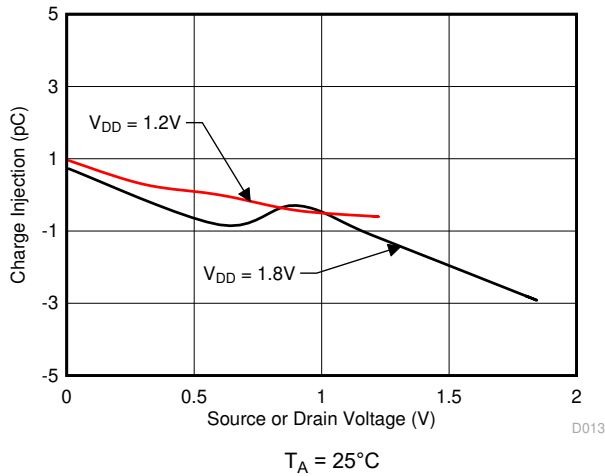

Figure 6-13. Charge Injection vs Source or Drain Voltage

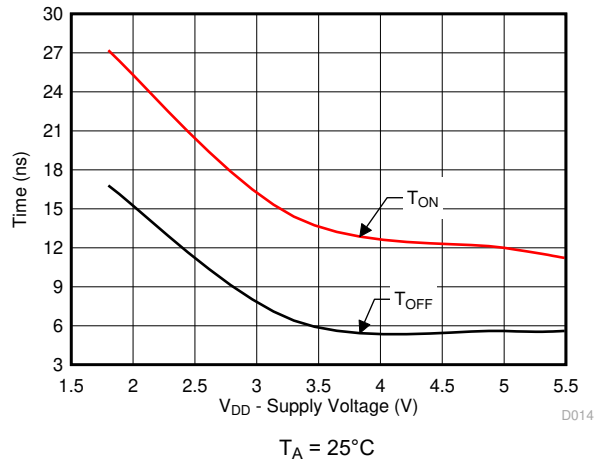

Figure 6-14. T_{ON} (EN) and T_{OFF} (EN) vs Supply Voltage

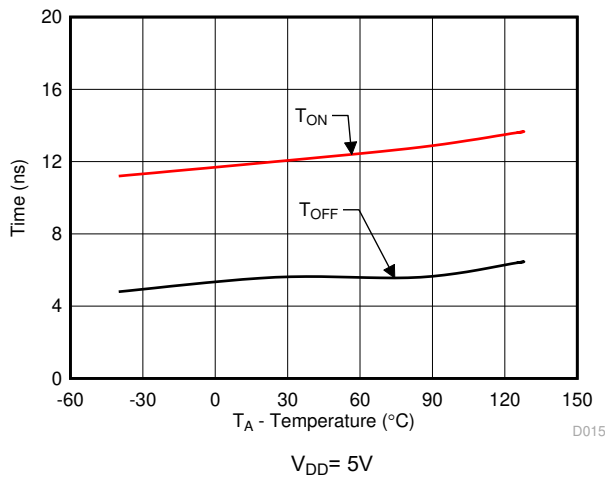

Figure 6-15. T_{ON} (EN) and T_{OFF} (EN) vs Temperature

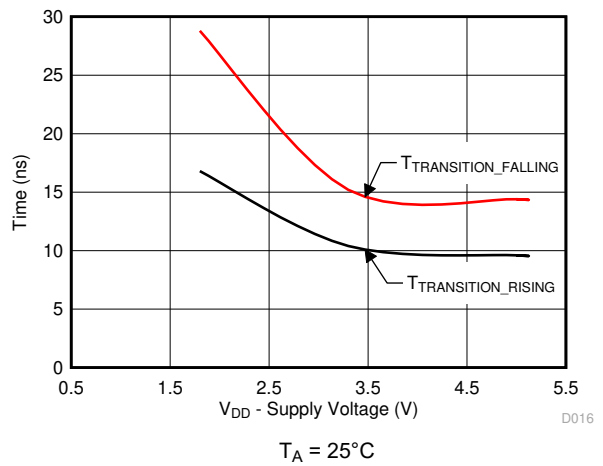

Figure 6-16. $T_{TRANSITION}$ vs Supply Voltage

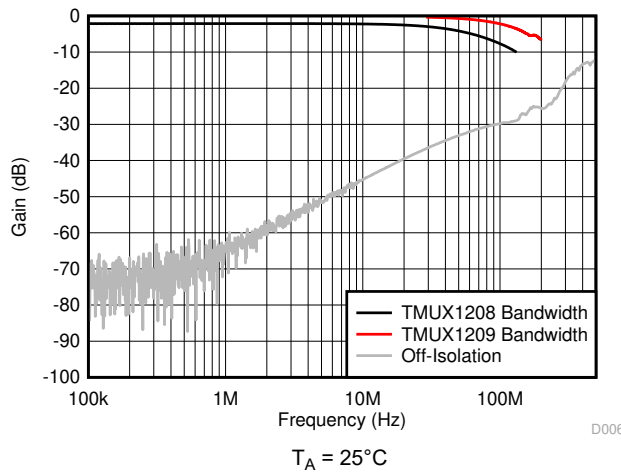

Figure 6-17. Frequency Response

7 Detailed Description

7.1 Overview

7.1.1 On-Resistance

The on-resistance of a device is the ohmic resistance between the source (Sx) and drain (D) pins of the device. The on-resistance varies with input voltage and supply voltage. The symbol R_{ON} is used to denote on-resistance. The measurement setup used to measure R_{ON} is shown in Figure 7-1. Voltage (V) and current (I_{SD}) are measured using this setup, and R_{ON} is computed with $R_{ON} = V / I_{SD}$:

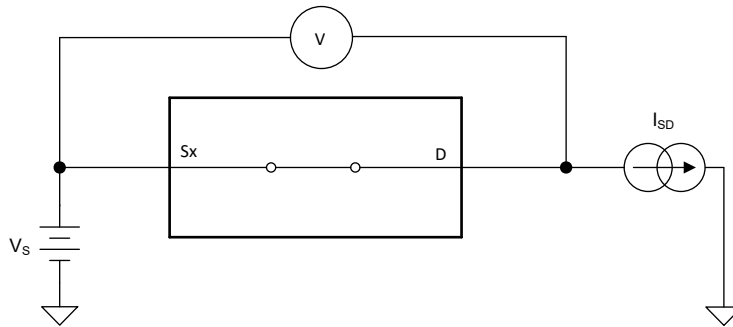

Figure 7-1. On-Resistance Measurement Setup

7.1.2 Off-Leakage Current

There are two types of leakage currents associated with a switch during the off state:

1. Source off-leakage current
2. Drain off-leakage current

Source leakage current is defined as the leakage current flowing into or out of the source pin when the switch is off. This current is denoted by the symbol $I_{S(OFF)}$.

Drain leakage current is defined as the leakage current flowing into or out of the drain pin when the switch is off. This current is denoted by the symbol $I_{D(OFF)}$.

The setup used to measure both off-leakage currents is shown in Figure 7-2.

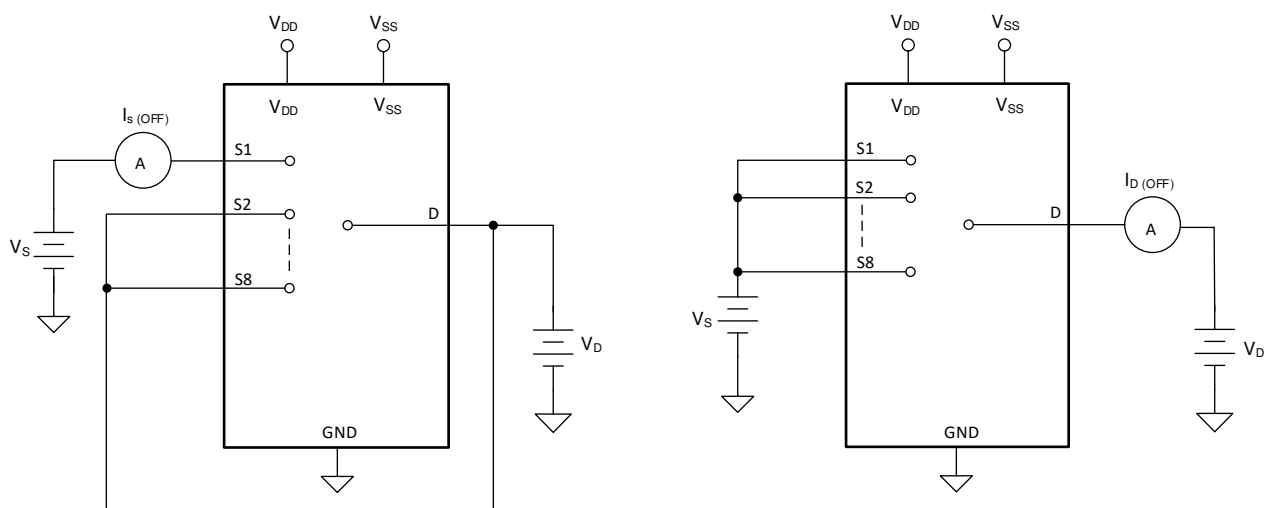

Figure 7-2. Off-Leakage Measurement Setup

7.1.3 On-Leakage Current

Source on-leakage current is defined as the leakage current flowing into or out of the source pin when the switch is on. This current is denoted by the symbol $I_{S(ON)}$.

Drain on-leakage current is defined as the leakage current flowing into or out of the drain pin when the switch is on. This current is denoted by the symbol $I_{D(ON)}$.

Either the source pin or drain pin is left floating during the measurement. Figure 7-3 shows the circuit used for measuring the on-leakage current, denoted by $I_{S(ON)}$ or $I_{D(ON)}$.

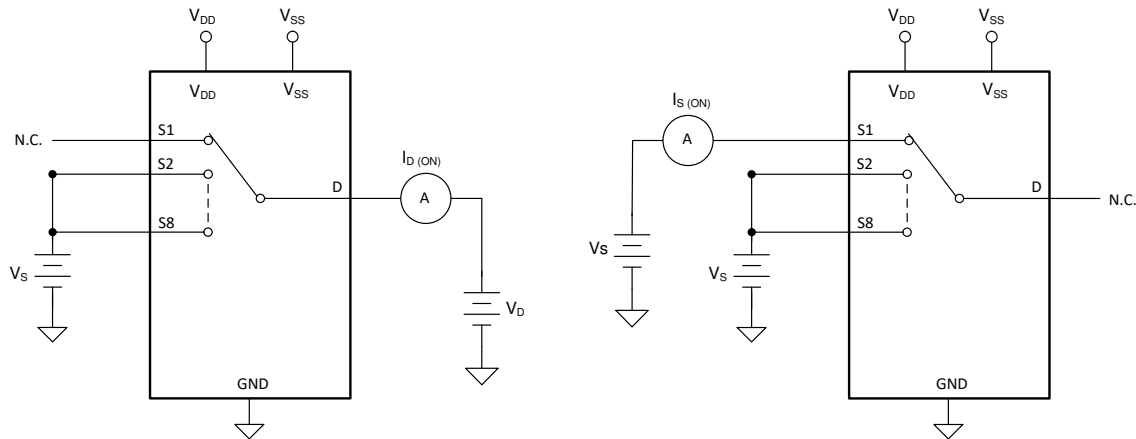

Figure 7-3. On-Leakage Measurement Setup

7.1.4 Transition Time

Transition time is defined as the time taken by the output of the device to rise or fall 10% after the address signal has risen or fallen past the logic threshold. The 10% transition measurement is utilized to provide the timing of the device, system level timing can then account for the time constant added from the load resistance and load capacitance. Figure 7-4 shows the setup used to measure transition time, denoted by the symbol $t_{TRANSITION}$.

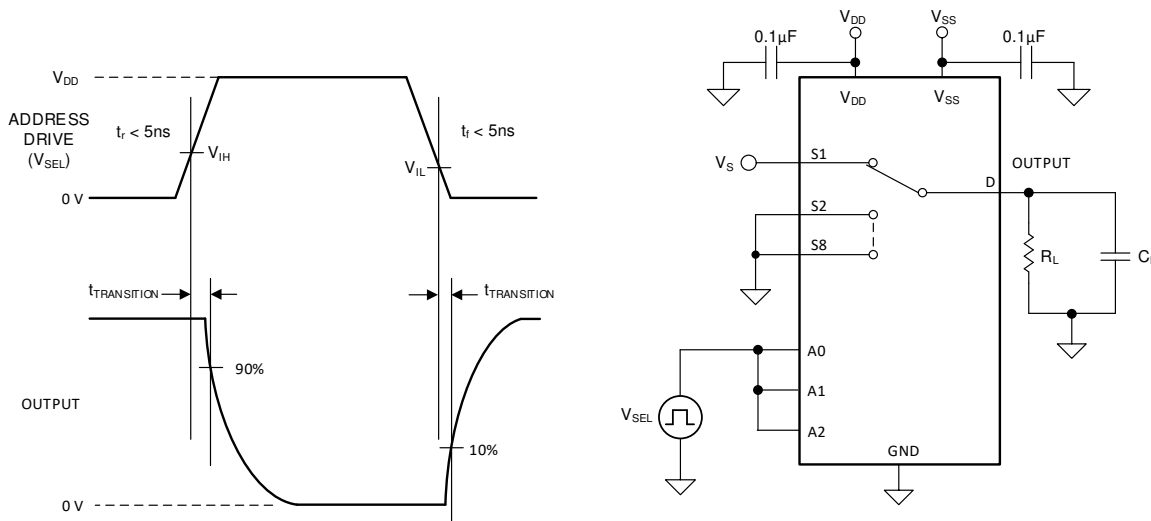

Figure 7-4. Transition-Time Measurement Setup

7.1.5 Break-Before-Make Delay

Break-before-make delay is a safety feature that prevents two inputs from connecting when the device is switching. The output first breaks from the on-state switch before making the connection with the next on-state switch. The time delay between the *break* and the *make* is known as break-before-make delay. Figure 7-5 shows the setup used to measure break-before-make delay, denoted by the symbol $t_{OPEN(BBM)}$.

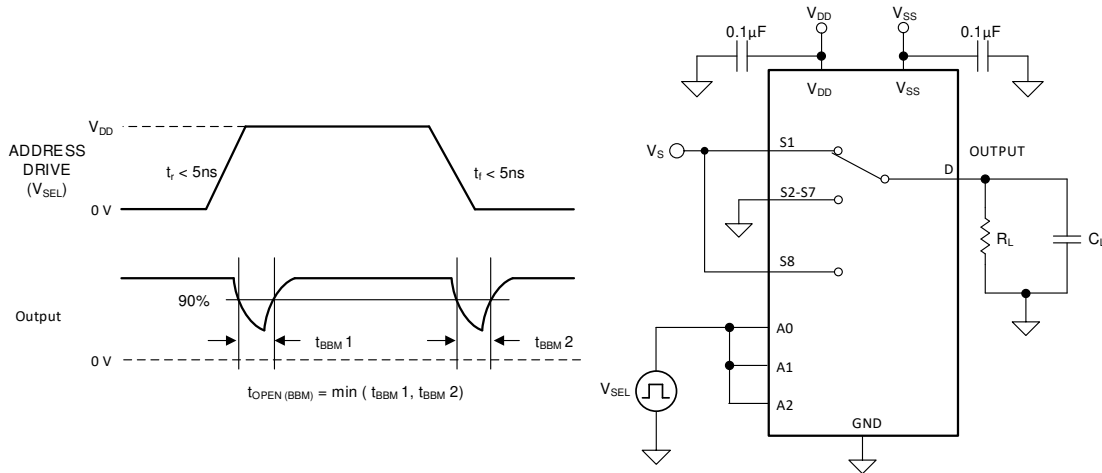

Figure 7-5. Break-Before-Make Delay Measurement Setup

7.1.6 Turn-On and Turn-Off Time

Turn-on time is defined as the time taken by the output of the device to rise to 10% after the enable has risen past the logic threshold. The 10% measurement is utilized to provide the timing of the device, system level timing can then account for the time constant added from the load resistance and load capacitance. Figure 7-6 shows the setup used to measure turn-on time, denoted by the symbol $t_{ON(EN)}$.

Turn-off time is defined as the time taken by the output of the device to fall to 90% after the enable has fallen past the logic threshold. The 90% measurement is utilized to provide the timing of the device, system level timing can then account for the time constant added from the load resistance and load capacitance. Figure 7-6 shows the setup used to measure turn-off time, denoted by the symbol $t_{OFF(EN)}$.

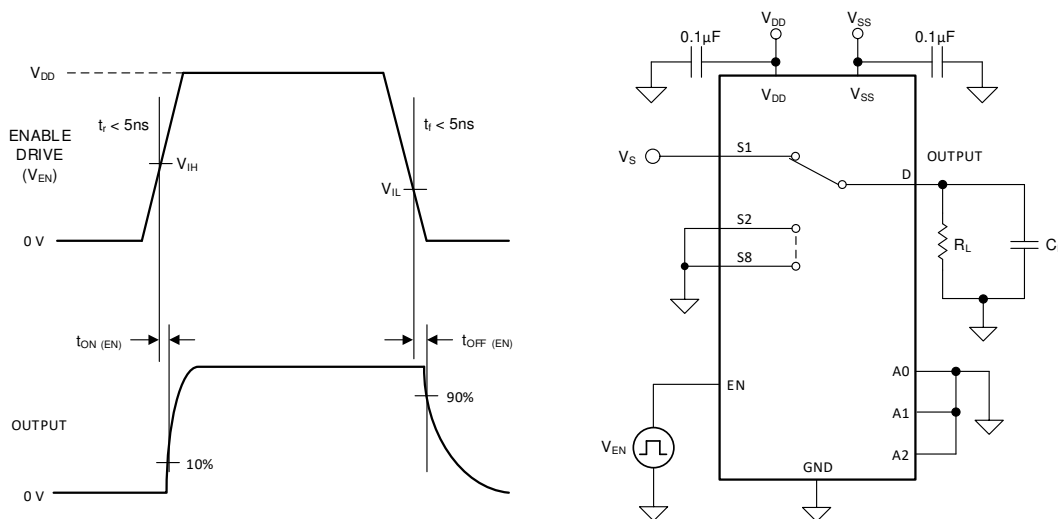

Figure 7-6. Turn-On and Turn-Off Time Measurement Setup

7.1.7 Charge Injection

The TMUX1108 has a transmission-gate topology. Any mismatch in capacitance between the NMOS and PMOS transistors results in a charge injected into the drain or source during the falling or rising edge of the gate signal. The amount of charge injected into the source or drain of the device is known as charge injection, and is denoted by the symbol Q_C . Figure 7-7 shows the setup used to measure charge injection from source (Sx) to drain (D).

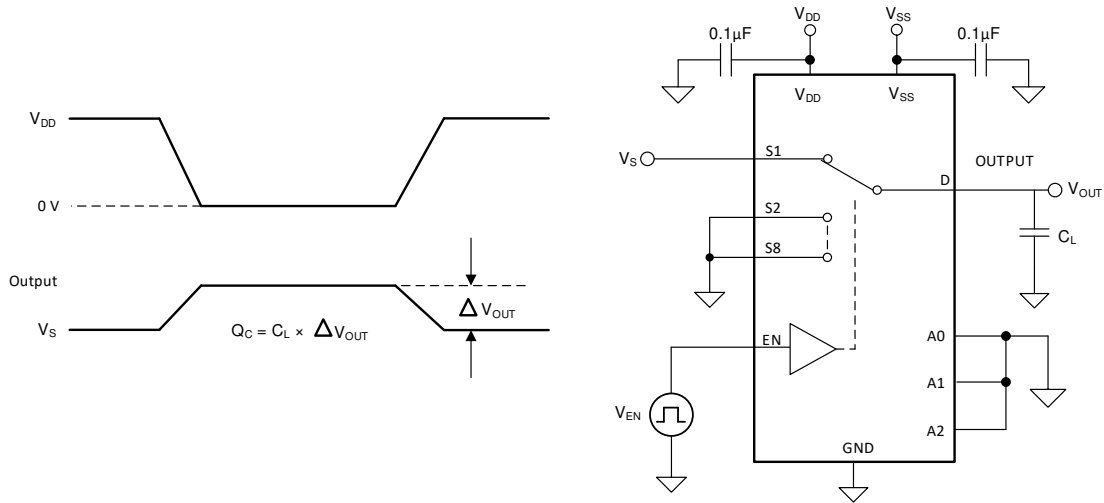

Figure 7-7. Charge-Injection Measurement Setup

7.1.8 Off Isolation

Off isolation is defined as the ratio of the signal at the drain pin (D) of the device when a signal is applied to the source pin (Sx) of an off-channel. Figure 7-8 shows the setup used to measure off isolation. Use the off isolation equation to compute off isolation.

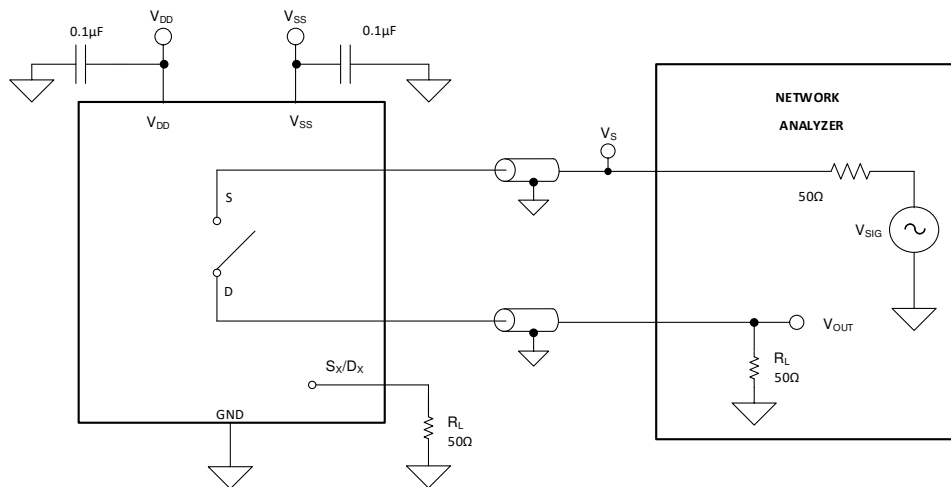

Figure 7-8. Off Isolation Measurement Setup

$$\text{Off Isolation} = 20 \cdot \text{Log} \left(\frac{V_{\text{OUT}}}{V_{\text{S}}} \right) \quad (1)$$

7.1.9 Crosstalk

Crosstalk is defined as the ratio of the signal at the drain pin (D) of a different channel, when a signal is applied at the source pin (Sx) of an on-channel. [Figure 7-9](#) shows the setup used to measure, and the equation used to compute crosstalk.

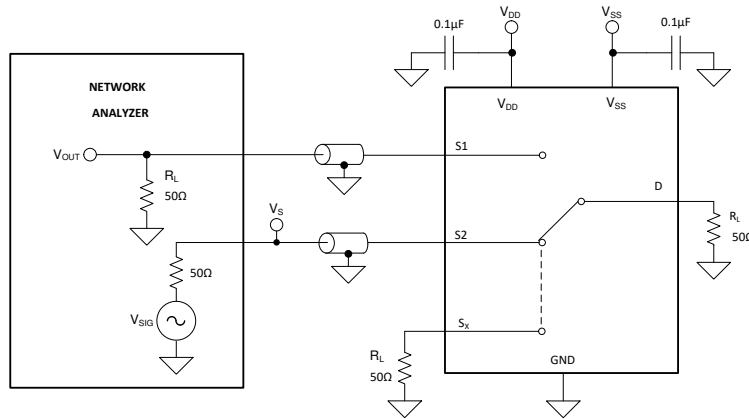

Figure 7-9. Crosstalk Measurement Setup

$$\text{Channel-to-Channel Crosstalk} = 20 \cdot \text{Log} \left(\frac{V_{\text{OUT}}}{V_S} \right) \tag{2}$$

7.1.10 Bandwidth

Bandwidth is defined as the range of frequencies that are attenuated by less than 3 dB when the input is applied to the source pin (Sx) of an on-channel, and the output is measured at the drain pin (D) of the device. [Figure 7-10](#) shows the setup used to measure bandwidth.

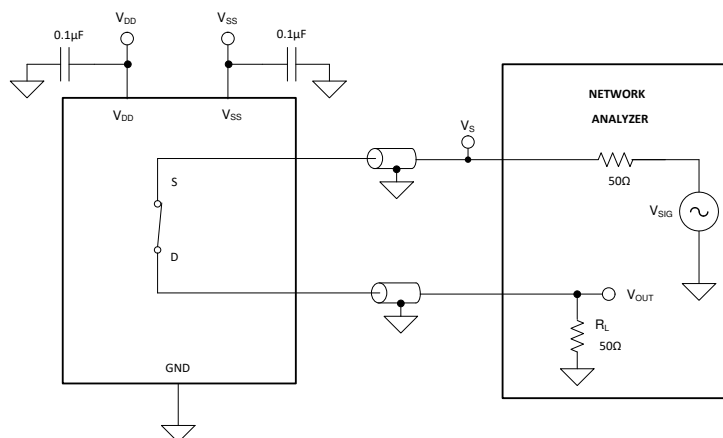

Figure 7-10. Bandwidth Measurement Setup

7.2 Functional Block Diagram

The TMUX1108 is an 8:1, single-ended (1-ch.), analog mux. Each channel is turned on or turned off based on the state of the address lines and enable pin.

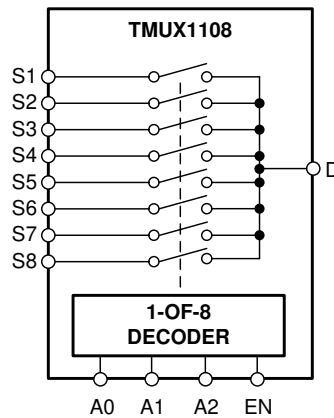

Figure 7-11. TMUX1108 Functional Block Diagram

7.3 Feature Description

7.3.1 Bidirectional Operation

The TMUX1108 conducts equally well from source (S_x) to drain (D) or from drain (D) to source (S_x). Each channel has very similar characteristics in both directions and supports both analog and digital signals.

7.3.2 Rail to Rail Operation

The valid signal path input/output voltage for TMUX1108 ranges from V_{SS} to V_{DD}.

7.3.3 1.8V Logic Compatible Inputs

The TMUX1108 has 1.8V logic compatible control for all logic control inputs. The logic input thresholds scale with supply but still provide 1.8V logic control when operating at 5.5V supply voltage. 1.8V logic level inputs allows the TMUX1108 to interface with processors that have lower logic I/O rails and eliminates the need for an external translator, which saves both space and BOM cost. For more information on 1.8V logic implementations refer to [Simplifying Design with 1.8V logic Muxes and Switches](#).

7.3.4 Fail-Safe Logic

The TMUX1108 support Fail-Safe Logic on the control input pins (EN, A0, A1, A2) allowing for operation up to 5.5V, regardless of the state of the supply pin. This feature allows voltages on the control pins to be applied before the supply pin, protecting the device from potential damage. Fail-Safe Logic minimizes system complexity by removing the need for power supply sequencing on the logic control pins. For example, the Fail-Safe Logic feature allows the select pins of the TMUX1108 to be ramped to 5.5V while V_{DD} = 0V. Additionally, the feature enables operation of the TMUX1108 with V_{DD} = 1.2V while allowing the select pins to interface with a logic level of another device up to 5.5V.

7.3.5 Ultra-low Leakage Current

The TMUX1108 provides extremely low on-leakage and off-leakage currents. The TMUX1108 is capable of switching signals from high source-impedance inputs into a high input-impedance op amp with minimal offset error because of the ultra-low leakage currents. Figure 7-12 shows typical leakage currents of the TMUX1108 versus temperature.

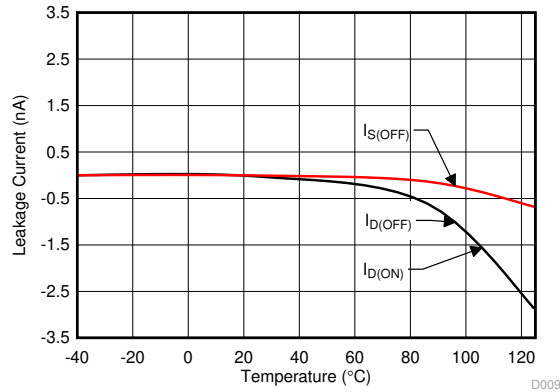

Figure 7-12. Leakage Current vs Temperature

7.3.6 Ultra-low Charge Injection

The TMUX1108 has a transmission gate topology, as shown in Figure 7-13. Any mismatch in the stray capacitance associated with the NMOS and PMOS causes an output level change whenever the switch is opened or closed.

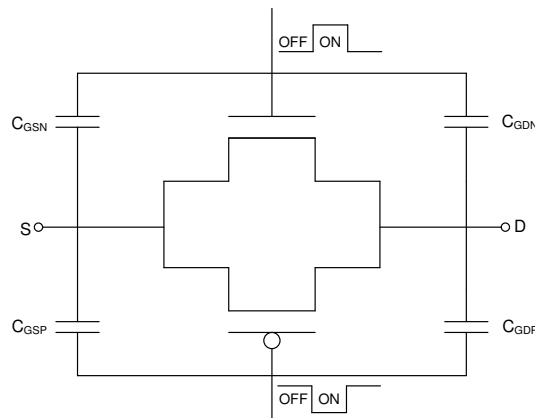

Figure 7-13. Transmission Gate Topology

The TMUX1108 has special charge-injection cancellation circuitry that reduces the source-to-drain charge injection to as low as 1pC at $V_S = 1V$ as shown in Figure 7-14.

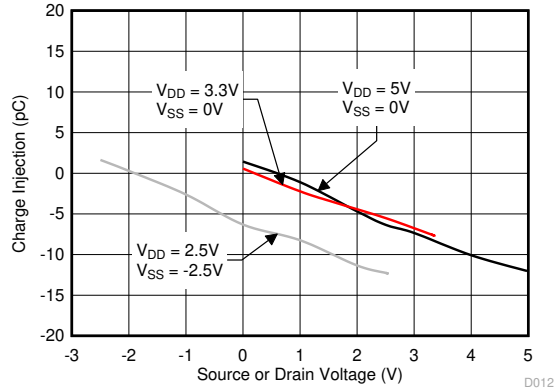

Figure 7-14. Charge Injection vs Source or Drain Voltage

7.4 Device Functional Modes

When the EN pin of the TMUX1108 is pulled high, one of the switches is closed based on the state of the address lines. When the EN pin is pulled low, all the switches are in an open state regardless of the state of the address lines.

7.4.1 Truth Tables

Table 7-1 shows the truth table for the TMUX1108.

Table 7-1. TMUX1108 Truth Table

EN	A2	A1	A0	Selected Channel Connected To Drain (D) Pin
0	X ⁽¹⁾	X ⁽¹⁾	X ⁽¹⁾	All channels are off
1	0	0	0	S1
1	0	0	1	S2
1	0	1	0	S3
1	0	1	1	S4
1	1	0	0	S5
1	1	0	1	S6
1	1	1	0	S7
1	1	1	1	S8

(1) X denotes *do not care*.

8 Application and Implementation

Note

Information in the following applications sections is not part of the TI component specification, and TI does not warrant its accuracy or completeness. TI's customers are responsible for determining suitability of components for their purposes, as well as validating and testing their design implementation to confirm system functionality.

8.1 Application Information

The TMUX11xx family offers ultra-low input/output leakage currents and low charge injection. These devices operate up to 5.5V, and offer true rail-to-rail input and output. The TMUX1108 has a low on-capacitance which allows faster settling time when multiplexing inputs in the time domain. These features make the TMUX11xx a family of precision, robust, high-performance analog multiplexer for low-voltage applications.

8.2 Typical Application

Figure 8-1 shows a 16-bit, 8 input, multiplexed, data-acquisition system. This example is typical in industrial applications that require low distortion for precision measurements. The circuit uses the ADS8864, a 16-bit, 400-kSPS successive-approximation-resistor (SAR) analog-to-digital converter (ADC), along with a precision amplifier, and an 8 input mux.

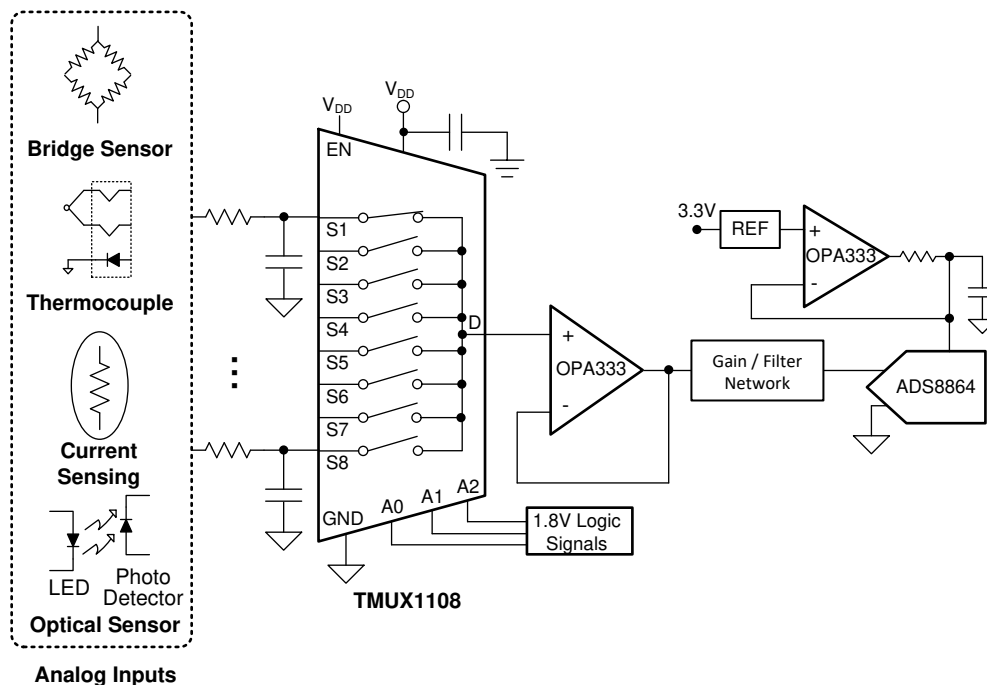

Figure 8-1. Multiplexing Signals to External ADC

8.2.1 Design Requirements

For this design example, use the parameters listed in Table 8-1.

Table 8-1. Design Parameters

PARAMETERS	VALUES
Supply (V_{DD})	3.3V
I/O signal range	0V to V_{DD} (Rail to Rail)
Control logic thresholds	1.8V compatible

8.2.2 Detailed Design Procedure

The TMUX1108 can operate without any external components except for the supply decoupling capacitors. If the device desired power-up state is disabled, the enable pin should have a weak pull-down resistor and be controlled by the MCU via GPIO. All inputs being muxed to the ADC must fall within the recommend operating conditions of the TMUX1108 including signal range and continuous current. For this design with a supply of 3.3V the signal range can be 0V to 3.3V and the maximum continuous current can be 30mA.

The design example highlights a multiplexed, data-acquisition system for highest system linearity and fast settling. The overall system block diagram is shown in [Figure 8-1](#). The circuit is a multichannel, data-acquisition signal chain consisting of an input low-pass filter, mux, mux output buffer, SAR ADC driver, and the reference buffer. The architecture allows fast sampling of multiple channels using a single ADC, providing a low-cost solution.

8.2.3 Application Curve

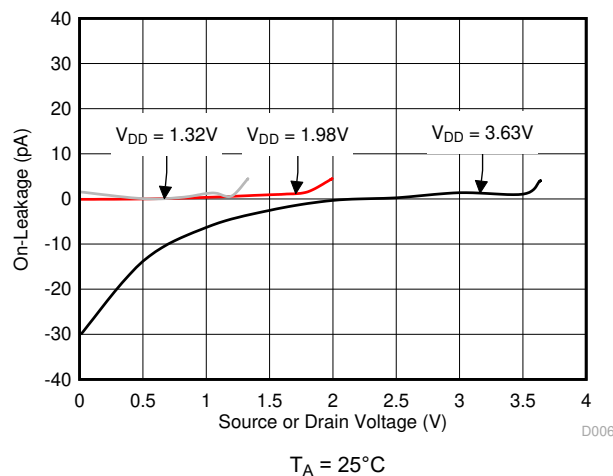

Figure 8-2. On-Leakage vs Source or Drain Voltage

8.3 Power Supply Recommendations

The TMUX1108 operates across a wide supply range of 1.08V to 5.5V. Do not exceed the absolute maximum ratings because stresses beyond the listed ratings can cause permanent damage to the devices.

Power-supply bypassing improves noise margin and prevents switching noise propagation from the V_{DD} supply to other components. Good power-supply decoupling is important to achieve optimum performance. For improved supply noise immunity, use a supply decoupling capacitor ranging from 0.1 μ F to 10 μ F from V_{DD} to ground. Place the bypass capacitors as close to the power supply pins of the device as possible using low-impedance connections. TI recommends using multi-layer ceramic chip capacitors (MLCCs) that offer low equivalent series resistance (ESR) and inductance (ESL) characteristics for power-supply decoupling purposes. For very sensitive systems or systems in harsh noise environments, connecting the capacitors to the device pins without vias may offer superior noise immunity. The use of multiple vias in parallel lowers the overall inductance and is beneficial for connections to ground planes.

8.4 Layout

8.4.1 Layout Guidelines

When a PCB trace turns a corner at a 90° angle, a reflection can occur. A reflection occurs primarily because of the change of width of the trace. At the apex of the turn, the trace width increases to 1.414 times the width. This increase upsets the transmission-line characteristics, especially the distributed capacitance and self-inductance of the trace which results in the reflection. Not all PCB traces can be straight and therefore some traces must turn corners. [Figure 8-3](#) shows progressively better techniques of rounding corners. Only the last example (BEST) maintains constant trace width and minimizes reflections.

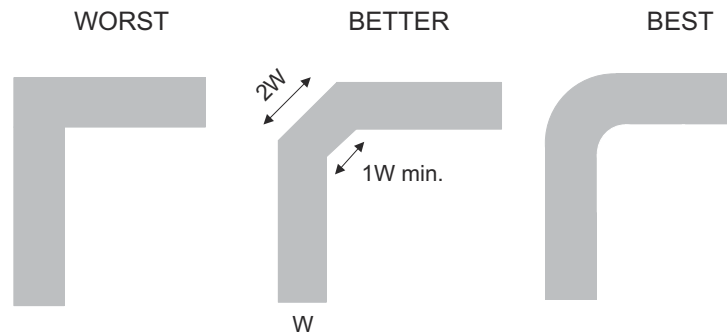

Figure 8-3. Trace Example

Route high-speed signals using a minimum of vias and corners which reduces signal reflections and impedance changes. When a via must be used, increase the clearance size around it to minimize its capacitance. Each via introduces discontinuities in the signal's transmission line and increases the chance of picking up interference from the other layers of the board. Be careful when designing test points, through-hole pins are not recommended at high frequencies.

[Figure 8-4](#) shows an example of a PCB layout with the TMUX1108. Some key considerations are as follows:

- Decouple the V_{DD} pin with a 0.1 μ F capacitor, placed as close to the pin as possible. Ensure that the capacitor voltage rating is sufficient for the V_{DD} supply.
- Keep the input lines as short as possible.
- Use a solid ground plane to help reduce electromagnetic interference (EMI) noise pickup.
- Do not run sensitive analog traces in parallel with digital traces. Avoid crossing digital and analog traces if possible, and only make perpendicular crossings when necessary.

8.4.2 Layout Example

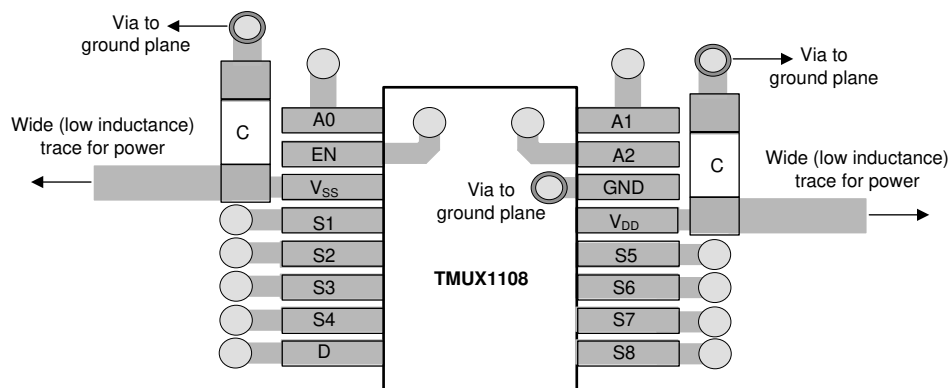

Figure 8-4. TMUX1108 Layout Example

9 Device and Documentation Support

9.1 Documentation Support

9.1.1 Related Documentation

For related documentation, see the following

- Texas Instruments, [Improve Stability Issues with Low CON Multiplexers](#).
- Texas Instruments, [Simplifying Design with 1.8V logic Muxes and Switches](#).
- Texas Instruments, [Eliminate Power Sequencing with Powered-off Protection Signal Switches](#).
- Texas Instruments, [System-Level Protection for High-Voltage Analog Multiplexers](#).
- Texas Instruments, [QFN/SON PCB Attachment](#).
- Texas Instruments, [Quad Flatpack No-Lead Logic Packages](#).

9.2 Receiving Notification of Documentation Updates

To receive notification of documentation updates, navigate to the device product folder on [ti.com](#). Click on *Notifications* to register and receive a weekly digest of any product information that has changed. For change details, review the revision history included in any revised document.

9.3 Support Resources

[TI E2E™ support forums](#) are an engineer's go-to source for fast, verified answers and design help — straight from the experts. Search existing answers or ask your own question to get the quick design help you need.

Linked content is provided "AS IS" by the respective contributors. They do not constitute TI specifications and do not necessarily reflect TI's views; see TI's [Terms of Use](#).

9.4 Trademarks

TI E2E™ is a trademark of Texas Instruments.
All trademarks are the property of their respective owners.

9.5 Electrostatic Discharge Caution



This integrated circuit can be damaged by ESD. Texas Instruments recommends that all integrated circuits be handled with appropriate precautions. Failure to observe proper handling and installation procedures can cause damage.

ESD damage can range from subtle performance degradation to complete device failure. Precision integrated circuits may be more susceptible to damage because very small parametric changes could cause the device not to meet its published specifications.

9.6 Glossary

[TI Glossary](#) This glossary lists and explains terms, acronyms, and definitions.

10 Revision History

NOTE: Page numbers for previous revisions may differ from page numbers in the current version.

Changes from Revision A (November 2018) to Revision B (February 2024) Page

- | | |
|---|---|
| • Updated Is or Id (Continuous Current) values..... | 4 |
| • Added Ipeak values to Recommended Operating Conditions table..... | 4 |

Changes from Revision * (November 2018) to Revision A (November 2018) Page

- | | |
|--|---|
| • Added footnotes to <i>Absolute Maximum Ratings</i> : table..... | 4 |
| • Added RSV (QFN) thermal information to <i>Thermal Information</i> : table..... | 5 |
| • Added footnote to clarify test conditions | 7 |
| • Changed leakage current test conditions for dual supply..... | 8 |

11 Mechanical, Packaging, and Orderable Information

The following pages include mechanical, packaging, and orderable information. This information is the most current data available for the designated devices. This data is subject to change without notice and revision of this document. For browser-based versions of this data sheet, refer to the left-hand navigation.

PACKAGING INFORMATION

Orderable Device	Status (1)	Package Type	Package Drawing	Pins	Package Qty	Eco Plan (2)	Lead finish/ Ball material (6)	MSL Peak Temp (3)	Op Temp (°C)	Device Marking (4/5)	Samples
TMUX1108PWR	ACTIVE	TSSOP	PW	16	2000	RoHS & Green	NIPDAU	Level-1-260C-UNLIM	-40 to 125	TM1108	Samples
TMUX1108RSVR	ACTIVE	UQFN	RSV	16	3000	RoHS & Green	NIPDAU	Level-1-260C-UNLIM	-40 to 125	1B2	Samples

(1) The marketing status values are defined as follows:

ACTIVE: Product device recommended for new designs.

LIFEBUY: TI has announced that the device will be discontinued, and a lifetime-buy period is in effect.

NRND: Not recommended for new designs. Device is in production to support existing customers, but TI does not recommend using this part in a new design.

PREVIEW: Device has been announced but is not in production. Samples may or may not be available.

OBSOLETE: TI has discontinued the production of the device.

(2) **RoHS:** TI defines "RoHS" to mean semiconductor products that are compliant with the current EU RoHS requirements for all 10 RoHS substances, including the requirement that RoHS substance do not exceed 0.1% by weight in homogeneous materials. Where designed to be soldered at high temperatures, "RoHS" products are suitable for use in specified lead-free processes. TI may reference these types of products as "Pb-Free".

RoHS Exempt: TI defines "RoHS Exempt" to mean products that contain lead but are compliant with EU RoHS pursuant to a specific EU RoHS exemption.

Green: TI defines "Green" to mean the content of Chlorine (Cl) and Bromine (Br) based flame retardants meet JS709B low halogen requirements of <=1000ppm threshold. Antimony trioxide based flame retardants must also meet the <=1000ppm threshold requirement.

(3) MSL, Peak Temp. - The Moisture Sensitivity Level rating according to the JEDEC industry standard classifications, and peak solder temperature.

(4) There may be additional marking, which relates to the logo, the lot trace code information, or the environmental category on the device.

(5) Multiple Device Markings will be inside parentheses. Only one Device Marking contained in parentheses and separated by a "~" will appear on a device. If a line is indented then it is a continuation of the previous line and the two combined represent the entire Device Marking for that device.

(6) Lead finish/Ball material - Orderable Devices may have multiple material finish options. Finish options are separated by a vertical ruled line. Lead finish/Ball material values may wrap to two lines if the finish value exceeds the maximum column width.

Important Information and Disclaimer:The information provided on this page represents TI's knowledge and belief as of the date that it is provided. TI bases its knowledge and belief on information provided by third parties, and makes no representation or warranty as to the accuracy of such information. Efforts are underway to better integrate information from third parties. TI has taken and continues to take reasonable steps to provide representative and accurate information but may not have conducted destructive testing or chemical analysis on incoming materials and chemicals. TI and TI suppliers consider certain information to be proprietary, and thus CAS numbers and other limited information may not be available for release.

In no event shall TI's liability arising out of such information exceed the total purchase price of the TI part(s) at issue in this document sold by TI to Customer on an annual basis.

TAPE AND REEL INFORMATION

QUADRANT ASSIGNMENTS FOR PIN 1 ORIENTATION IN TAPE

*All dimensions are nominal

Device	Package Type	Package Drawing	Pins	SPQ	Reel Diameter (mm)	Reel Width W1 (mm)	A0 (mm)	B0 (mm)	K0 (mm)	P1 (mm)	W (mm)	Pin1 Quadrant
TMUX1108PWR	TSSOP	PW	16	2000	330.0	12.4	6.9	5.6	1.6	8.0	12.0	Q1
TMUX1108RSVR	UQFN	RSV	16	3000	178.0	13.5	2.1	2.9	0.75	4.0	12.0	Q1

TAPE AND REEL BOX DIMENSIONS

*All dimensions are nominal

Device	Package Type	Package Drawing	Pins	SPQ	Length (mm)	Width (mm)	Height (mm)
TMUX1108PWR	TSSOP	PW	16	2000	356.0	356.0	35.0
TMUX1108RSVR	UQFN	RSV	16	3000	189.0	185.0	36.0

EXAMPLE BOARD LAYOUT

RSV0016A

UQFN - 0.55 mm max height

ULTRA THIN QUAD FLATPACK - NO LEAD

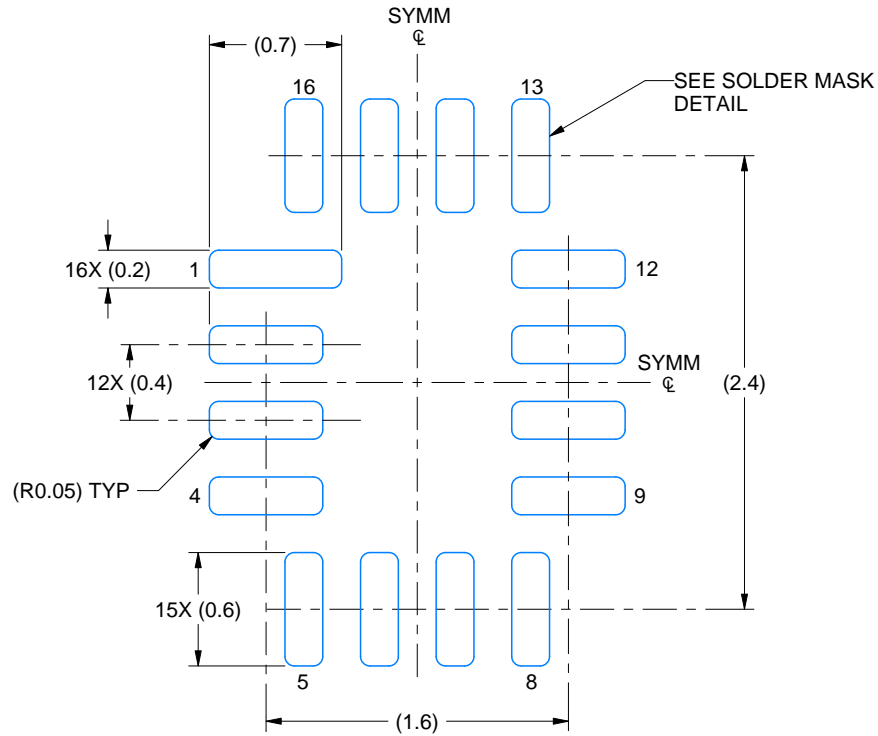

LAND PATTERN EXAMPLE
EXPOSED METAL SHOWN
SCALE: 25X

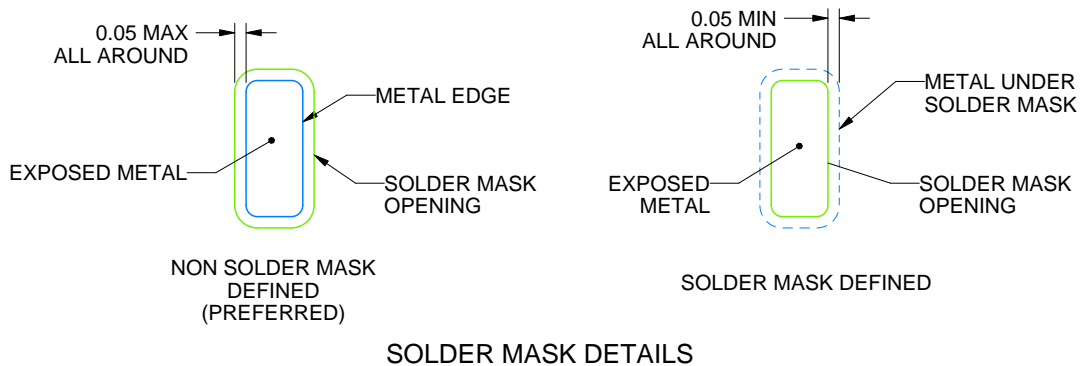

4220314/C 02/2020

NOTES: (continued)

3. For more information, see Texas Instruments literature number SLUA271 (www.ti.com/lit/slua271).

EXAMPLE STENCIL DESIGN

RSV0016A

UQFN - 0.55 mm max height

ULTRA THIN QUAD FLATPACK - NO LEAD

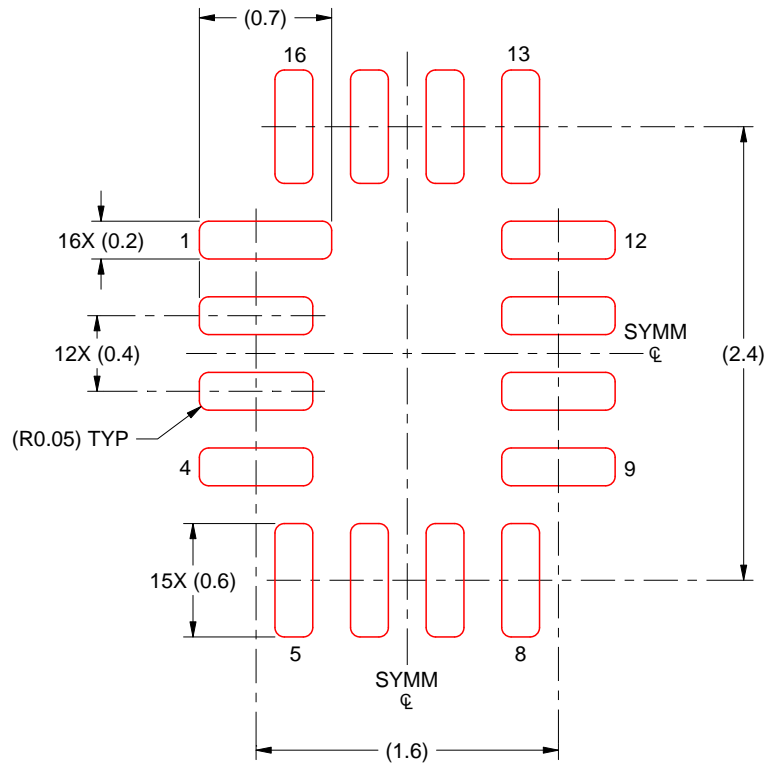

SOLDER PASTE EXAMPLE
BASED ON 0.125 MM THICK STENCIL
SCALE: 25X

4220314/C 02/2020

NOTES: (continued)

4. Laser cutting apertures with trapezoidal walls and rounded corners may offer better paste release. IPC-7525 may have alternate design recommendations.



4220204/A 02/2017

NOTES:

1. All linear dimensions are in millimeters. Any dimensions in parenthesis are for reference only. Dimensioning and tolerancing per ASME Y14.5M.
2. This drawing is subject to change without notice.
3. This dimension does not include mold flash, protrusions, or gate burrs. Mold flash, protrusions, or gate burrs shall not exceed 0.15 mm per side.
4. This dimension does not include interlead flash. Interlead flash shall not exceed 0.25 mm per side.
5. Reference JEDEC registration MO-153.

EXAMPLE BOARD LAYOUT

PW0016A

TSSOP - 1.2 mm max height

SMALL OUTLINE PACKAGE



LAND PATTERN EXAMPLE
EXPOSED METAL SHOWN
SCALE: 10X



4220204/A 02/2017

NOTES: (continued)

- 6. Publication IPC-7351 may have alternate designs.
- 7. Solder mask tolerances between and around signal pads can vary based on board fabrication site.

EXAMPLE STENCIL DESIGN

PW0016A

TSSOP - 1.2 mm max height

SMALL OUTLINE PACKAGE

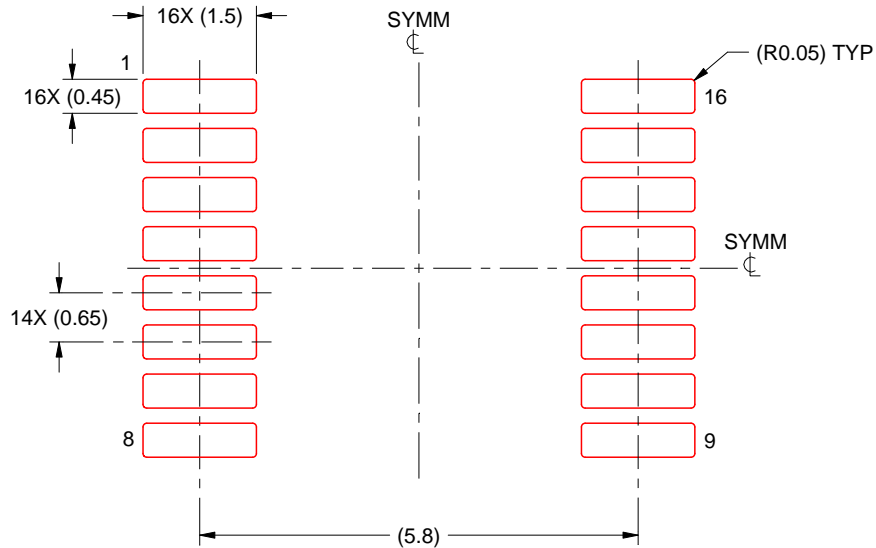

SOLDER PASTE EXAMPLE
BASED ON 0.125 mm THICK STENCIL
SCALE: 10X

4220204/A 02/2017

NOTES: (continued)

8. Laser cutting apertures with trapezoidal walls and rounded corners may offer better paste release. IPC-7525 may have alternate design recommendations.
9. Board assembly site may have different recommendations for stencil design.

IMPORTANT NOTICE AND DISCLAIMER

TI PROVIDES TECHNICAL AND RELIABILITY DATA (INCLUDING DATA SHEETS), DESIGN RESOURCES (INCLUDING REFERENCE DESIGNS), APPLICATION OR OTHER DESIGN ADVICE, WEB TOOLS, SAFETY INFORMATION, AND OTHER RESOURCES "AS IS" AND WITH ALL FAULTS, AND DISCLAIMS ALL WARRANTIES, EXPRESS AND IMPLIED, INCLUDING WITHOUT LIMITATION ANY IMPLIED WARRANTIES OF MERCHANTABILITY, FITNESS FOR A PARTICULAR PURPOSE OR NON-INFRINGEMENT OF THIRD PARTY INTELLECTUAL PROPERTY RIGHTS.

These resources are intended for skilled developers designing with TI products. You are solely responsible for (1) selecting the appropriate TI products for your application, (2) designing, validating and testing your application, and (3) ensuring your application meets applicable standards, and any other safety, security, regulatory or other requirements.

These resources are subject to change without notice. TI grants you permission to use these resources only for development of an application that uses the TI products described in the resource. Other reproduction and display of these resources is prohibited. No license is granted to any other TI intellectual property right or to any third party intellectual property right. TI disclaims responsibility for, and you will fully indemnify TI and its representatives against, any claims, damages, costs, losses, and liabilities arising out of your use of these resources.

TI's products are provided subject to [TI's Terms of Sale](#) or other applicable terms available either on [ti.com](https://www.ti.com) or provided in conjunction with such TI products. TI's provision of these resources does not expand or otherwise alter TI's applicable warranties or warranty disclaimers for TI products.

TI objects to and rejects any additional or different terms you may have proposed.

Mailing Address: Texas Instruments, Post Office Box 655303, Dallas, Texas 75265
Copyright © 2024, Texas Instruments Incorporated

Looking for pricing, stock, or lifecycle information?

Click below to explore more details on WIN SOURCE:

- ⊖ [View HIF3BA-14D-2.54R on WIN SOURCE](#)
- ⊖ [Hirose Electric Co Ltd Information](#)

Optimize Your Supply Chain with WIN SOURCE Solutions

- ✓ Global Sourcing Solution
- ✓ Obsolete Management
- ✓ Cost Control Management
- ✓ Shortage Management
- ✓ Alternative Solution
- ✓ Excess Inventory Management