



**THE DATASHEET OF  
OQ021250000G**





PRODUCT NUMBER	SERIES NAME	PITCH
20020107-CXXXXXXLF	06-350	3.50 mm

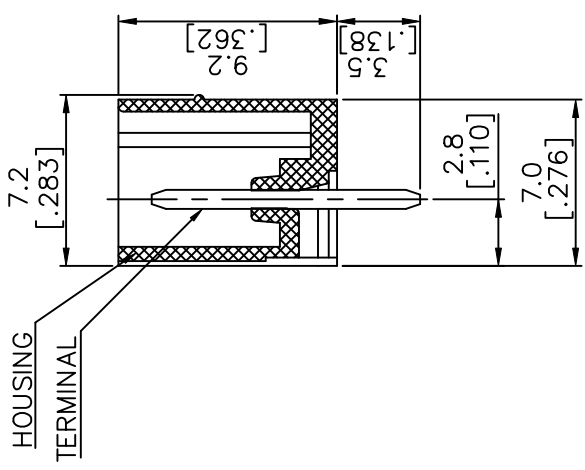
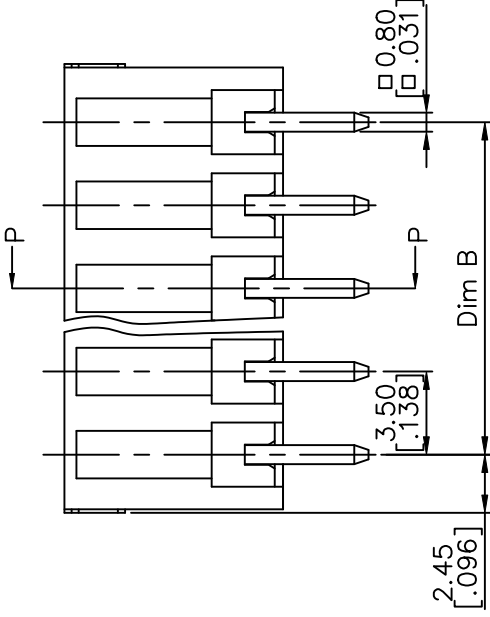
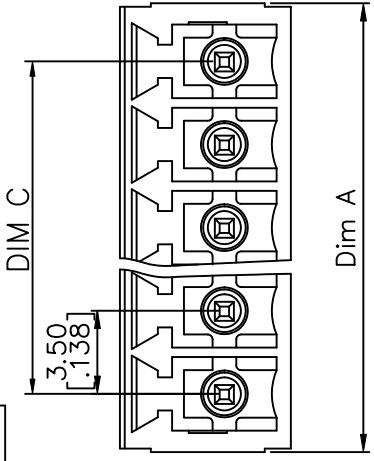

SECTION P-P

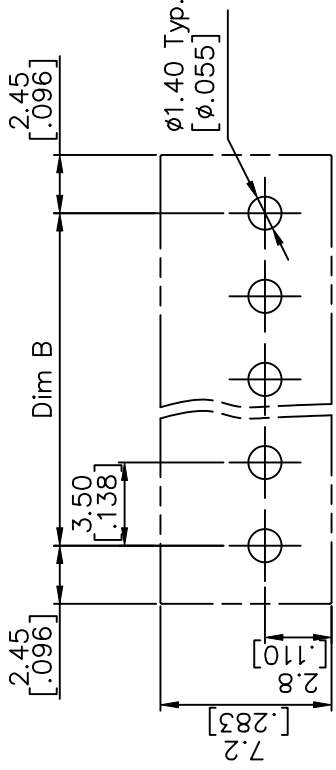

RECOMMENDED P.C.B LAYOUT

mat'l. code	surface	tr
	ASME Y14.5	AS
itr	ecn no	dr date
k		
	tolerances unless	
	angles	X.X
		X.XX
	X±1*	
	dr	BEER FU
	engr	BEER FU
	chr	GARY HSIEN
	appd	JOSEPH HSIAO
sheet	revision	
index	sheet	

PRODUCT NUMBER	SERIES NAME	PITCH
20020107-DXXXXXXLF	06-381	3.81 mm

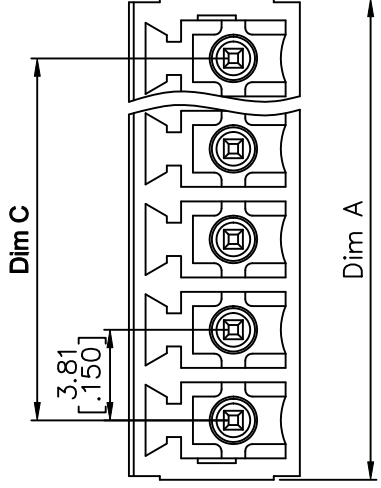

HOUSING  
TERMINAL

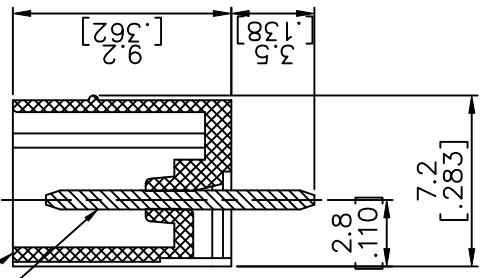
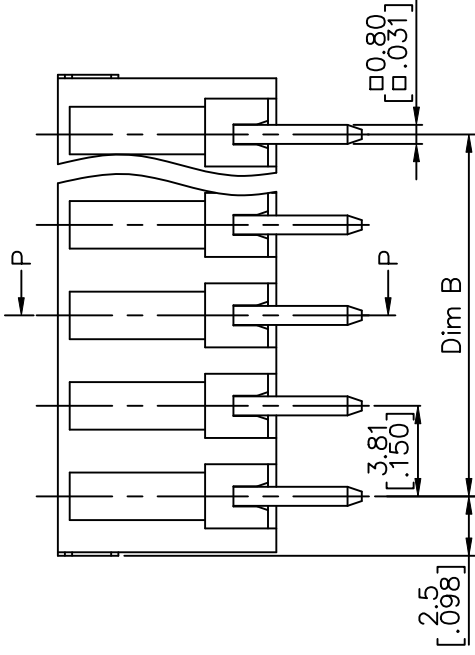

SECTION P-P

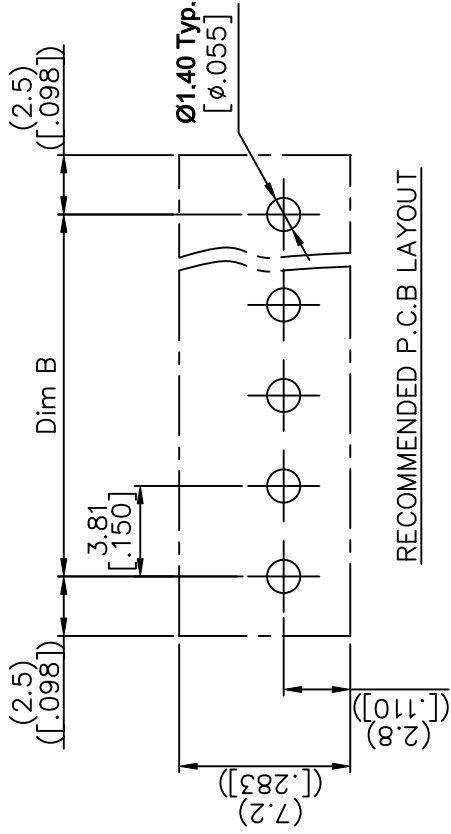

RECOMMENDED P.C.B LAYOUT

mat'l. code	tr	ecn	no	dr	date	surface	tc
	k					ASME Y14.5	AS
						tolerances unless	
						angles	X.X
						X±1°	X.XX
						dr	BEER FU
						engr	BEER FU
						chr	GARY HSI
						appd	JOSEPH HS
sheet	revision						
index	sheet						

PRODUCT NUMBER	SERIES NAME	PITCH
20020107-GXXXXXLF	06-500	5.00 mm

N = NI
DIMENS
Dim A
Dim B
Dim C
Pole
2p-
7p-
13p-
17p-

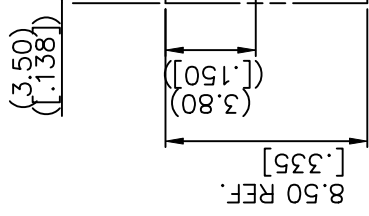
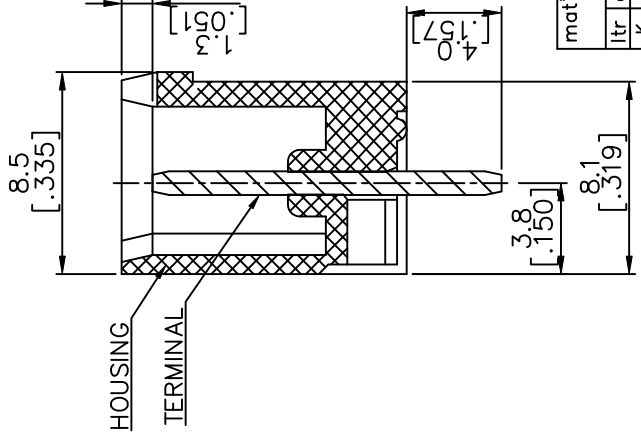
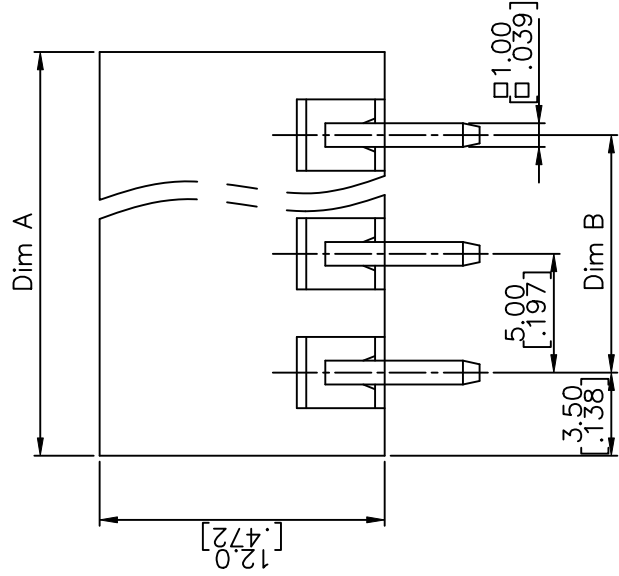
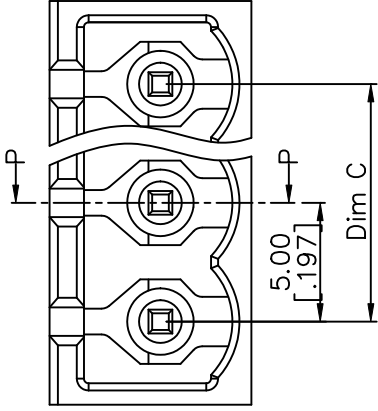

8.50 REF.  
[.335]

SECTION P-P

mat'l. code	tr	ecn	no	dr	date	surface	tc
	k					ASME Y14.5	ASME Y14.5
						tolerances unless	tolerances unless
						angles	angles
						X±1*	X.X
						X±1*	X.XX
						dr	BEER FU
						engr	BEER FU
						chr	GARY HSIEN
						appd	JOSEPH HS
sheet						revision	
index						sheet	

PRODUCT NUMBER	SERIES NAME	PITCH
20020107-HXXXXXLF	06-508	5.08 mm

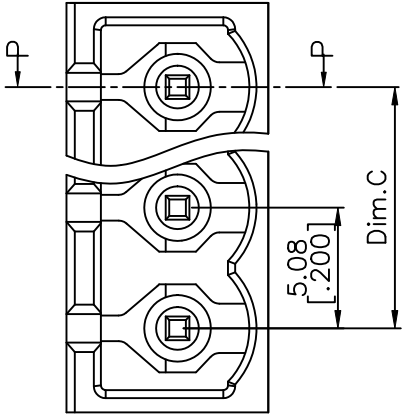

N = NUM	DIMENSIO
Dim A	N
Dim B	(0
Dim C	(0
Poles	
2p-6p	
7p-12	
13p-11	
17p-2	

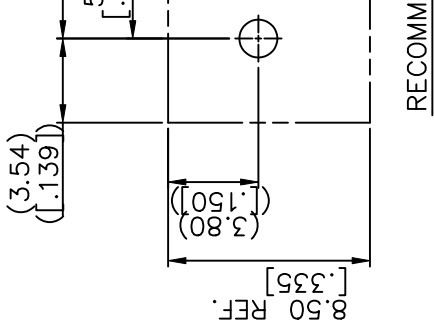
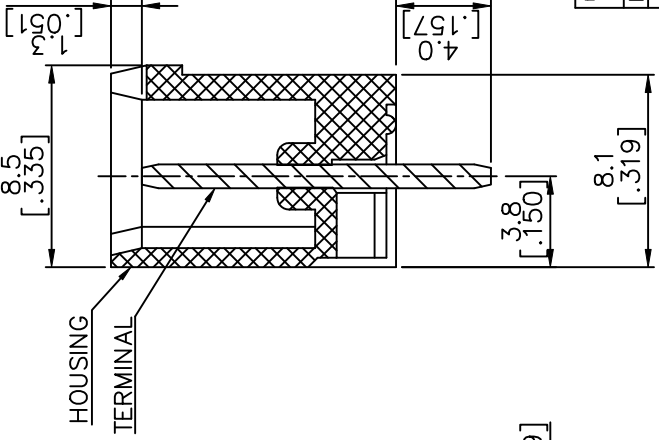
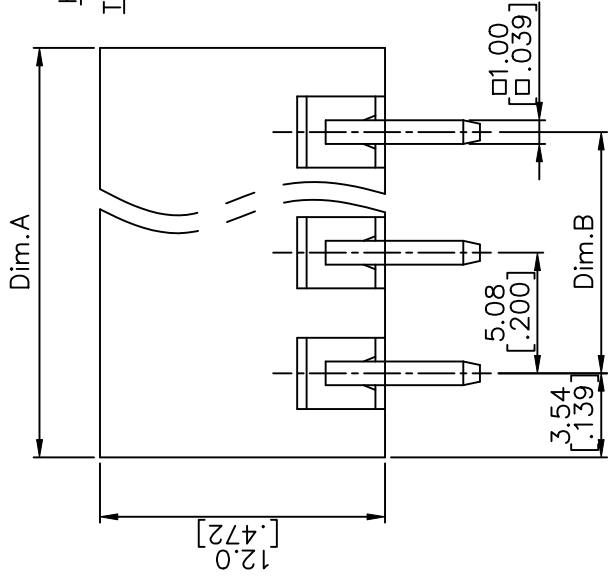

mat'l. code	surface	tolerances unless
itr	ASME Y14.5	ASME Y14.5
ecn		
no		
dr		
date		
k		
	angles	X.X
		X.X
		X.XX
	dr	BEER FU
	engr	BEER FU
	chr	GARY HSIEN
	appd	JOSEPH HS
sheet	revision	
index	sheet	

## Looking for pricing, stock, or lifecycle information?

Click below to explore more details on WIN SOURCE:

-  [View OQ0212500000G on WIN SOURCE](#)
-  [Amphenol Anytek Information](#)

## Optimize Your Supply Chain with WIN SOURCE Solutions

-  Global Sourcing Solution
-  Obsolete Management
-  Cost Control Management
-  Shortage Management
-  Alternative Solution
-  Excess Inventory Management