



# THE DATASHEET OF LTV-0501





# Photocouplers

## LTV-0501

### Data Sheet

Created Date : 01/ 02/ 2012  
Revision : 1.0, 01/ 02/ 2012



Lite-on Technology Corp.  
Optoelectronics SBG  
<http://www.liteon.com/opto>



## Photocouplers LTV-0501

### 1. DESCRIPTION

The LTV-0501 consists of a high efficient AlGaAs Light Emitting Diode and a high speed optical detector. This design provides excellent AC and DC isolation between the input and output sides of the Optocoupler. Connection for the bias of the photodiode improves the speed that of a conventional phototransistor coupler by reducing the base-collector capacitances. A guaranteed common mode transient immunity is up to 1KV/ $\mu$ sec.

#### 1.1 Features

- SO8 package
- High speed – 1MBd typical
- Available in Dual-in-line, Wide lead spacing, Surface mounting package.
- Storable output.

#### 1.2 Applications

- High Voltage Isolation
- Isolation in line receivers
- Feedback element in switching mode power supplier
- Power transistor isolation in motor drives
- Interface between Microprocessor system, computer and their periphe
- Replace pulse transformers.
- Replace slower optocoupler isolators.

#### 1.3 Functional Diagram

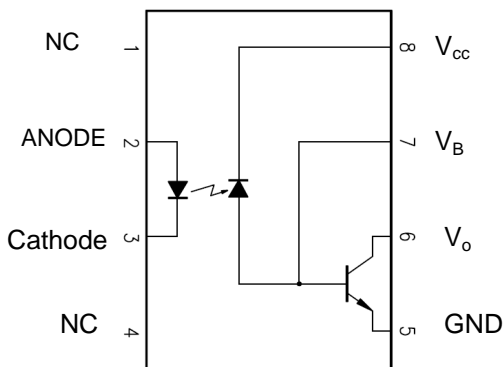

Truth Table (Positive Logic)

LED	OUT
ON	L
OFF	H

A 0.1 $\mu$ F bypass Capacitor must be connected between Pin8 and Pin5

**Photocouplers  
LTV-0501**

**2. PACKAGE DIMENSIONS**

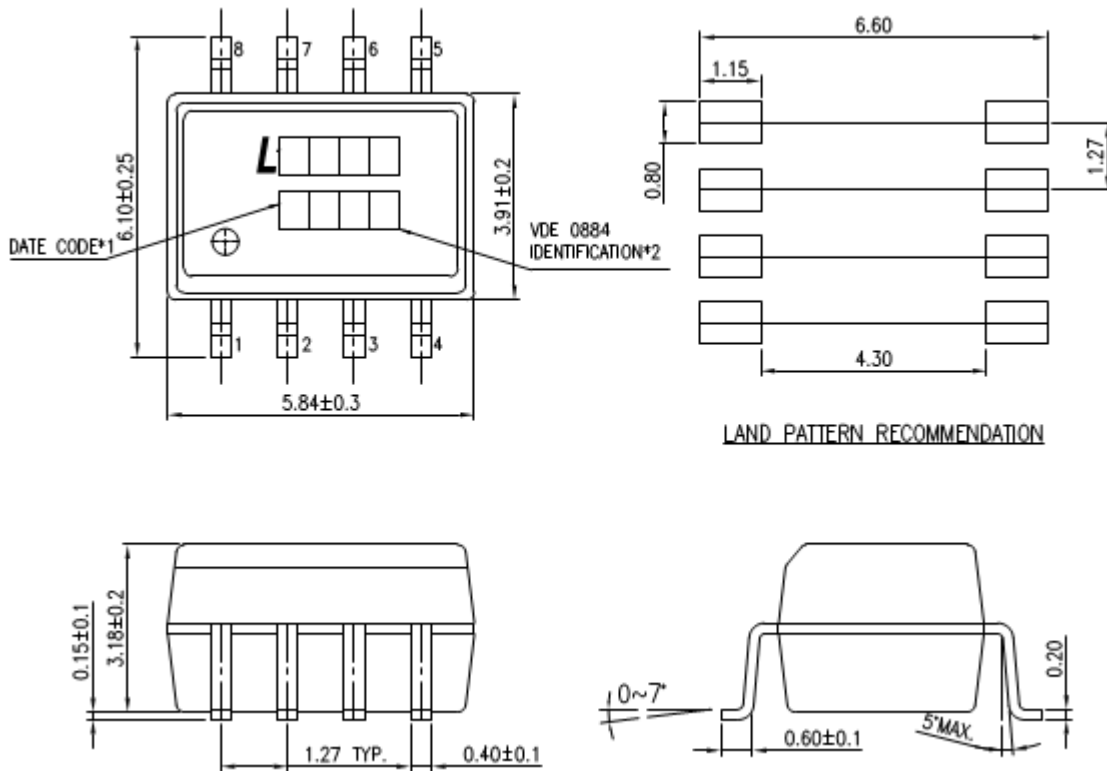

Part No : LTV-0501

**Notes :**

1. Date code
2. "V" to represent VDE0884
3. Date code
4. Dimensions are all in Millimeters.

## Photocouplers LTV-0501

### 3. TAPING DIMENSIONS

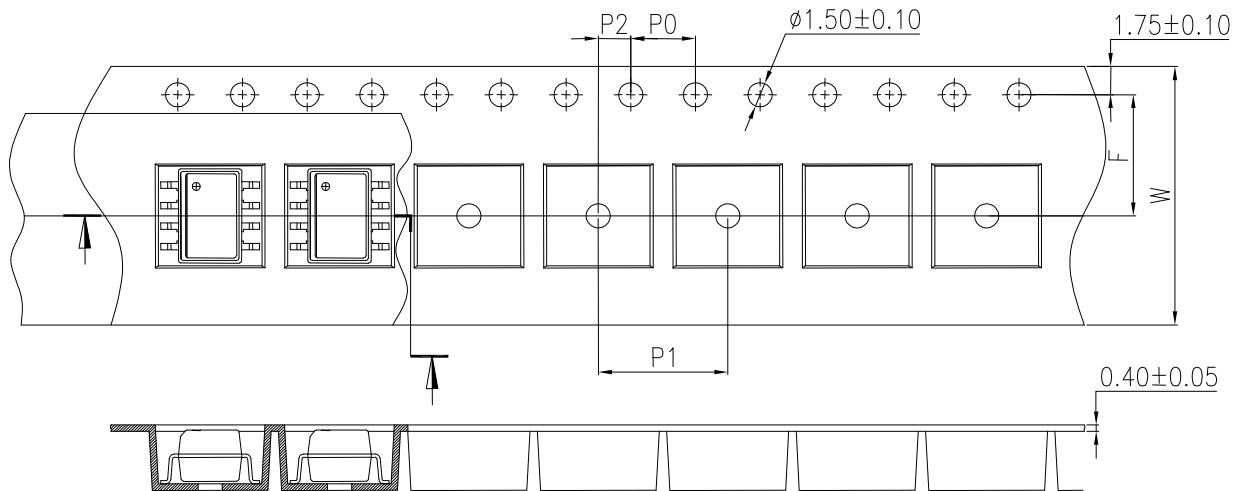

Description	Symbol	Dimension in mm (inch)
Tape wide	W	16±0.3 (0.63)
Pitch of sprocket holes	P <sub>0</sub>	4±0.1 (0.15)
Distance of compartment	F	7.5±0.1 (0.295)
	P <sub>2</sub>	2±0.1 (0.079)
Distance of compartment to compartment	P <sub>1</sub>	8±0.1 (0.47)

### Quantities Per Reel

Package Type	LTV-0501
Quantities (pcs)	2000

## Photocouplers LTV-0501

### 4. RATING AND CHARACTERISTICS

#### 4.1 Absolute Maximum Ratings at Ta=25°C \*1

	Parameter	Symbol	Rating	Unit
Input	Average Forward Input Current	$I_F$	25	mA
	Reverse Input Voltage	$V_R$	5	V
	Power Dissipation	$P_I$	45	mW
Output	Output Collector Current	$I_O$	8	mA
	Output Collector Voltage	$V_O$	-0.5~15	V
	Output Collector Power Dissipation	$P_O$	100	mW
	Isolation Voltage	$V_{iso}$	3750	$V_{rms}$
	Supply Voltage	$V_{CC}$	-0.5~15	V
	Operating Temperature	$T_{opr}$	-55 ~ +100	°C
	Storage Temperature	$T_{stg}$	-55 ~ +125	°C
	Lead Solder Temperature *2	$T_{sol}$	260	°C

1. Ambient temperature = 25°C, unless otherwise specified. Stresses exceeding the absolute maximum ratings can cause permanent damage to the device. Exposure to absolute maximum ratings for long periods of time can adversely affect reliability.
2. 260°C for 10 seconds. Refer to Lead Free Reflow Profile.

## Photocouplers LTV-0501

### 4.2 ELECTRICAL OPTICAL CHARACTERISTICS at Ta=25°C

Parameter	Symbol	Min.	Typ.	Max.	Unit	Test Conition
<b>Input</b>						
Input Forward Voltage	$V_F$	—	—	1.8	V	$I_F=16\text{mA}$ , $T_A=25^\circ\text{C}$
Input Reverse Voltage	$BV_R$	5.0	—	—	V	$I_R = 10\mu\text{A}$
<b>Detector</b>						
Current transfer ratio	CTR	19	24	50	%	$I_F=16\text{mA}$ ; $V_{CC}=4.5\text{V}$ ; $T_A=25^\circ\text{C}$ ; $V_o=0.4\text{V}$
		15	25	—		$I_F=16\text{mA}$ ; $V_{CC}=4.5\text{V}$ ; $T_A=25^\circ\text{C}$ ; $V_o=0.5\text{V}$
Logic low output voltage output voltage	$V_{OL}$	—	0.1	0.4	V	$I_F=16\text{mA}$ ; $V_{CC}=4.5\text{V}$ ; $I_o=3.0\text{mA}$ ; $T_A=25^\circ\text{C}$
		—	0.1	0.5		$I_F=16\text{mA}$ ; $V_{CC}=4.5\text{V}$ ; $I_o=2.4\text{mA}$ ; $T_A=25^\circ\text{C}$
Logic high output current	$I_{OH}$	—	0.003	0.5	$\mu\text{A}$	$I_F=0\text{mA}$ , $V_o=V_{CC}=5.5\text{V}$ $T_A=25^\circ\text{C}$
		—	0.01	1		$I_F=0\text{mA}$ , $V_o=V_{CC}=15\text{V}$ $T_A=25^\circ\text{C}$
		—	—	50		$V_o = V_{CC} = 15\text{V}$
Logic low supply current	$I_{ccl}$	—	50	200	$\mu\text{A}$	$I_F=16\text{mA}$ , $V_o=\text{open}$ ( $V_{CC}=15\text{V}$ )
Logic high supply current	$I_{cch}$	—	0.02	1	$\mu\text{A}$	$I_F=0\text{mA}$ , $V_o=\text{open}$ ; $T_A=25^\circ\text{C}$ ( $V_{CC}=15\text{V}$ )

\*All Typical at  $T_A=25^\circ\text{C}$

## Photocouplers LTV-0501

### 5. SWITCHING SPECIFICATION

$T_A=0\sim 70^{\circ}\text{C}$ ,  $V_{CC}=5\text{V}$ , unless otherwise specified.

Parameter	Symbol	Min.	Typ.	Max.	Unit	Test Conition
Propagation Delay Time to Low Output Level	$t_{PHL}$	—	0.2	0.8	$\mu\text{s}$	$T_A=25^{\circ}\text{C}$ ( $R_L=1.9\text{K}\Omega$ , $I_F=16\text{mA}$ )
Propagation Delay Time to High Output Level	$t_{PLH}$	—	0.6	0.8	$\mu\text{s}$	$T_A=25^{\circ}\text{C}$ ( $R_L=1.9\text{K}\Omega$ , $I_F=16\text{mA}$ )
Logic High Common Mode Transient Immunity	$ CM_H $	—	1	—	$\text{KV}/\mu\text{s}$	$I_F=0\text{mA}$ ; $V_{CM}=10\text{Vp-p}$ ; $C_L = 15\text{ pF}$ ; $T_A=25\text{C}$
Logic Low Common Mode Transient Immunity	$ CM_L $	—	1	—	$\text{KV}/\mu\text{s}$	$I_F=0\text{mA}$ ; $V_{CM}=10\text{Vp-p}$ ; $C_L = 15\text{ pF}$ ; $T_A=25\text{C}$

\*All Typical at  $T_A=25^{\circ}\text{C}$

### 6. ISOLATION CHARACTERISTIC

Parameter	Symbol	Min.	Typ.	Max.	Unit	Test Conition
Input-Output Insulation Leakage Current	$I_{I-O}$	—	—	1.0	$\mu\text{A}$	45% RH, $t = 5\text{s}$ , $V_{I-O} = 3\text{kV DC}$ , $T_A = 25^\circ\text{C}$
Withstand Insulation Test Voltage	$V_{ISO}$	3750	—	—	$V_{RMS}$	$RH \leq 50\%$ , $t = 1\text{min}$ , $T_A = 25^\circ\text{C}$
Input-Output Resistance	$R_{I-O}$	—	$10^{12}$	—	$\Omega$	$V_{I-O} = 500\text{V DC}$

\*All Typical at  $T_A = 25^\circ\text{C}$

#### Notes

1. A 0.1 $\mu\text{F}$  or bigger bypass capacitor for  $V_{CC}$  is needed as shown in Fig.1
2. Current Transfer Ratio is defined as the ratio of output collector current  $I_O$ , to the forward LED input current  $I_F$ , times 100.
3. The 1.9K $\Omega$  load represents 1TTL unit load of 1.6mA and the 5.6K $\Omega$  pull-up resistor.
4. The 4.1K $\Omega$  load represents 1LSTTL unit load of 0.36mA and the 6.1K $\Omega$  pull-up resistor.

# Photocouplers LTV-0501

## 7. CHARACTERISTICS CURVES

Figure 1: DC and pulsed transfer characteristics

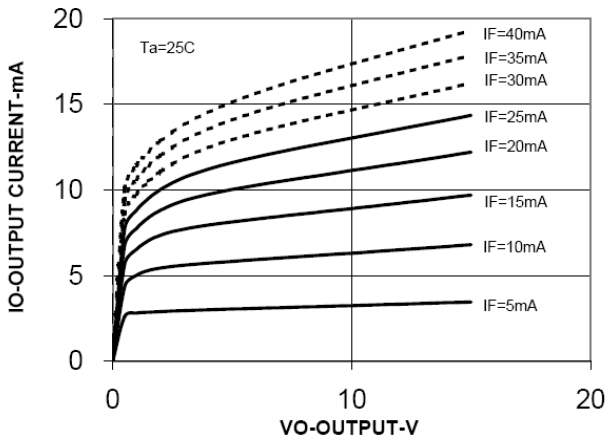

Figure 2: Input current vs. forward voltage

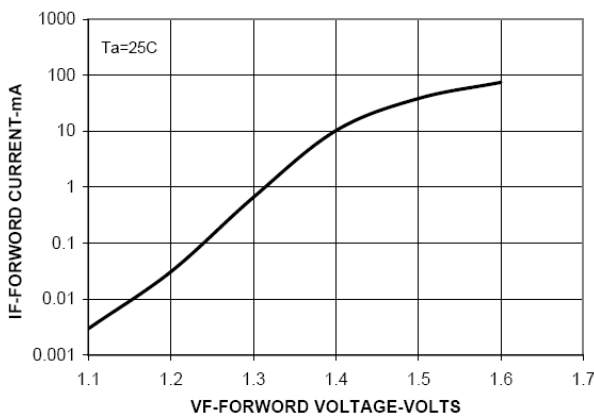

Figure 3: Logic high output current vs. temperature

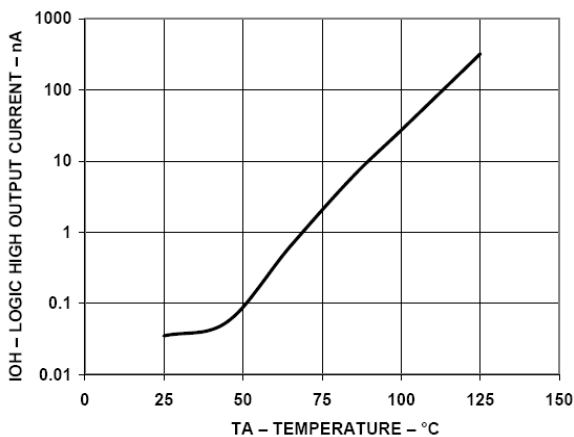

Figure 4: Current transfer ratio vs. input current

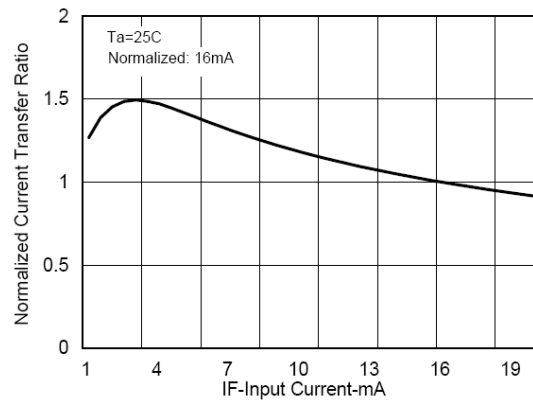

Figure 5: Current transfer ratio vs. temperature

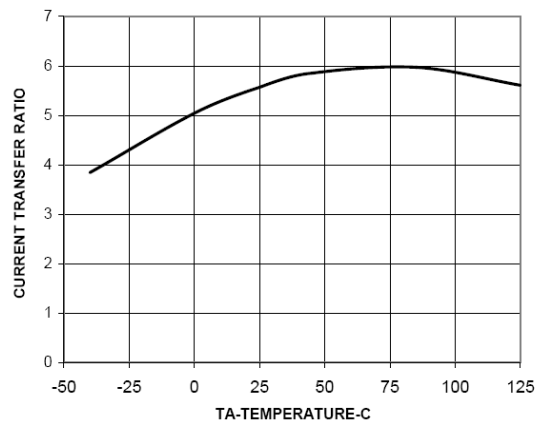
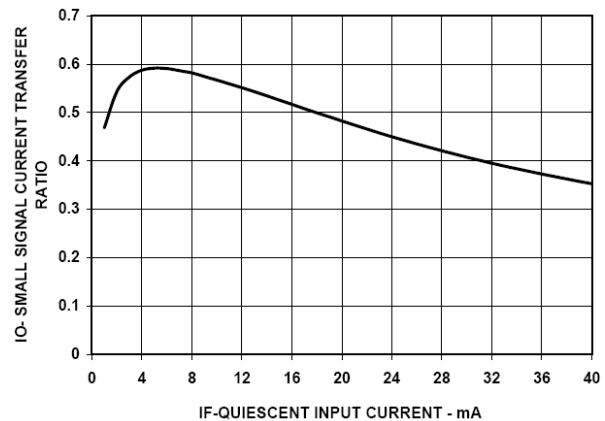

Figure 6: Small-signal current transfer ratio vs. quiescent current



Photocouplers  
LTV-0501

Figure 7: Propagation delay time vs. temperature

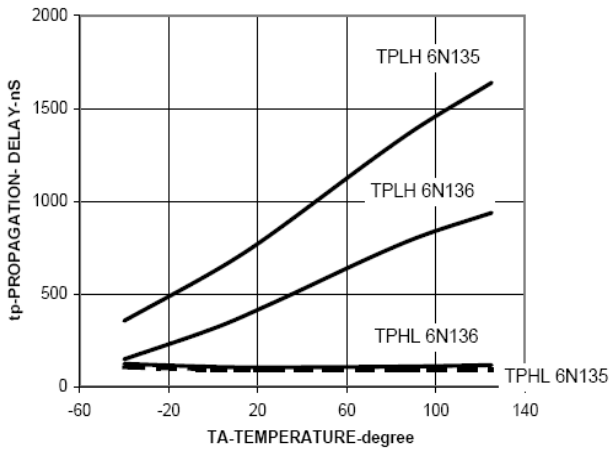
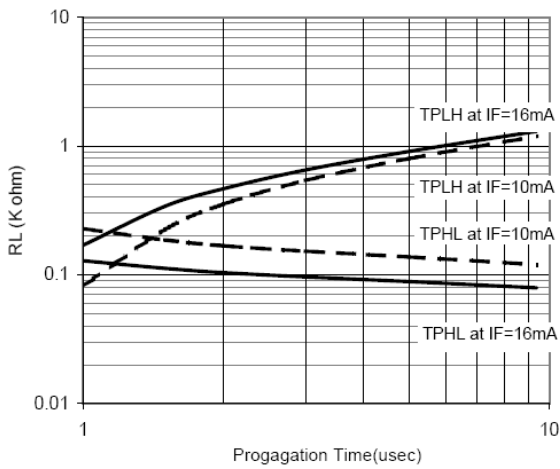

Figure 8: Propagation delay time vs. load resistance



8. Switching Time Test Circuit

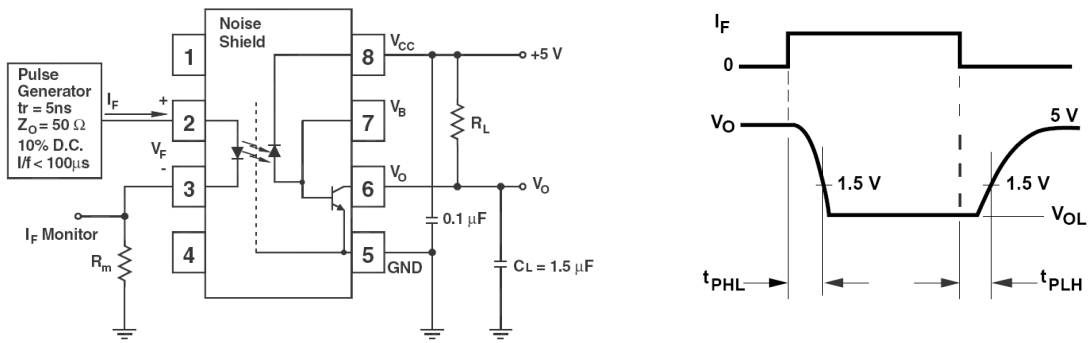

Figure 1: Single Channel Test Circuit for  $t_{PHL}$  and  $t_{PLH}$

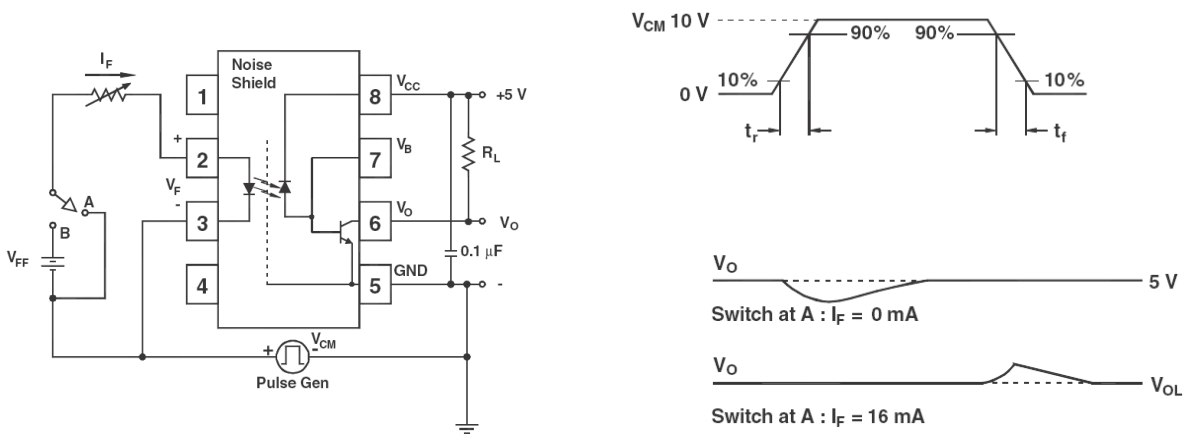

Figure 2: Single Channel Test Circuit for Common Mode Transient Immunity

## 9. TEMPERATURE PROFILE OF SOLDERING

### 9.1 IR Reflow soldering (JEDEC-STD-020C compliant)

One time soldering reflow is recommended within the condition of temperature and time profile shown below. Do not solder more than three times.

Profile item	Conditions
Preheat	
- Temperature Min ( $T_{Smin}$ )	150°C
- Temperature Max ( $T_{Smax}$ )	200°C
- Time (min to max) (ts)	90±30 sec
Soldering zone	
- Temperature ( $T_L$ )	217°C
- Time ( $t_L$ )	60 sec
Peak Temperature ( $T_P$ )	260°C
Ramp-up rate	3°C / sec max.
Ramp-down rate	3~6°C / sec

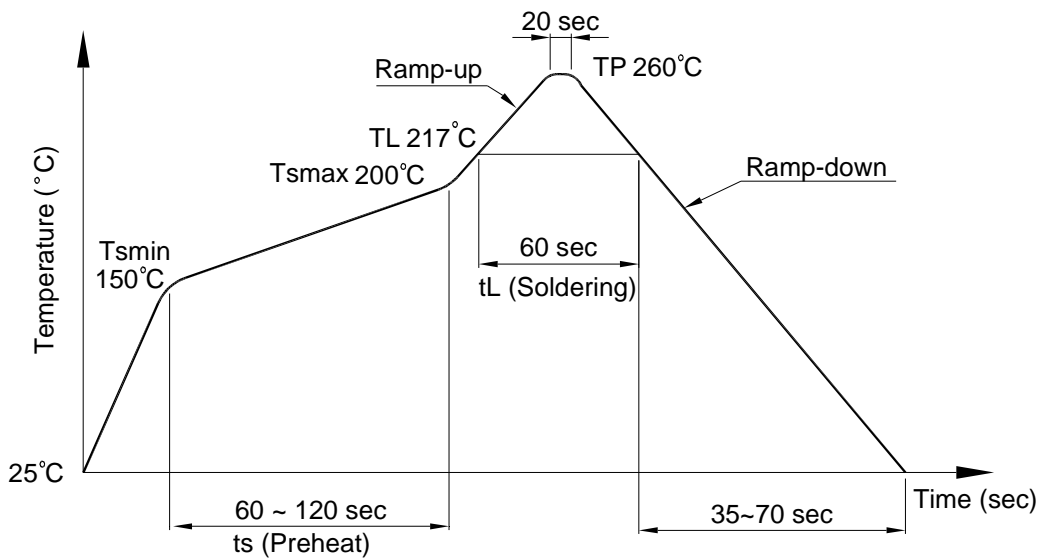

**Photocouplers  
LTV-0501**

**9.2 Wave soldering (JEDEC22A111 compliant)**

One time soldering is recommended within the condition of temperature.

Temperature:  $260 \pm 0/-5^{\circ}\text{C}$

Time: 10 sec.

Preheat temperature: 25 to  $140^{\circ}\text{C}$

Preheat time: 30 to 80 sec.

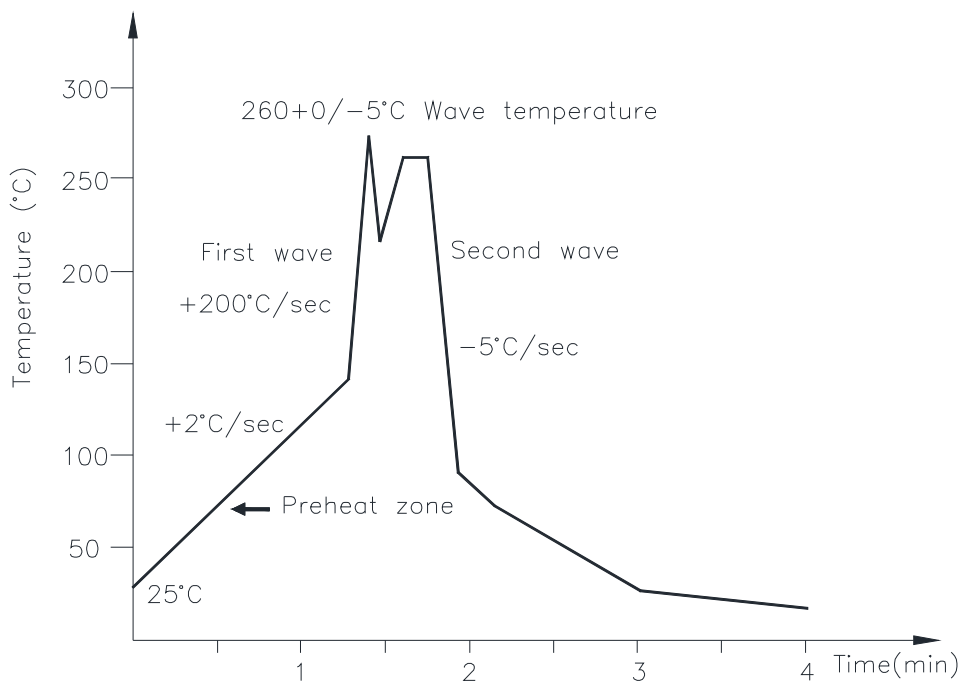

**9.3 Hand soldering by soldering iron**

Allow single lead soldering in every single process. One time soldering is recommended.

Temperature:  $380 \pm 0/-5^{\circ}\text{C}$

Time: 3 sec max.



**10. Notes:**

Specifications of the products displayed herein are subject to change without notice.

The products shown in this publication are designed for the general use in electronic applications such as office automation equipment, communications devices, audio/visual equipment, electrical instrumentation and application. For equipment/devices where high reliability or safety is required, such as space applications, nuclear power control equipment, medical equipment, etc, please contact our sales representatives.

## Looking for pricing, stock, or lifecycle information?

Click below to explore more details on WIN SOURCE:

-  [View LTV-0501 on WIN SOURCE](#)
-  [Lite-On Inc. Information](#)

## Optimize Your Supply Chain with WIN SOURCE Solutions

-  Global Sourcing Solution
-  Obsolete Management
-  Cost Control Management
-  Shortage Management
-  Alternative Solution
-  Excess Inventory Management