



**THE DATASHEET OF  
FOD8173**



# FOD8173, FOD8173T

## 3.3 V/5 V, 20 Mbit/sec, Logic Gate Optocoupler in Stretched Body SOP 6-Pin

### Description

The FOD8173 series packaged in a stretched body 6-pin small outline plastic package, consists of an aluminum gallium arsenide (AlGaAs) light emitting diode and a CMOS detector IC comprises an integrated photodiode, a high speed transimpedance amplifier and a voltage comparator with a totem-pole output driver. The electrical and switching characteristics are guaranteed over the extended industrial temperature range of  $-40^{\circ}\text{C}$  to  $100^{\circ}\text{C}$  and a  $V_{\text{DD}}$  range of 3 V to 5.5 V.

### Features

- FOD8173T – 8 mm Creepage and Clearance Distance, and 0.4 mm insulation distance to achieve reliable and high voltage insulation
- High Noise Immunity characterized by common mode transient immunity (CMTI)
- 20 kV/ $\mu\text{s}$  Minimum CMTI
- 3.3 V and 5 V CMOS Compatibility
- Specifications Guaranteed Over 3 V to 5.5 V supply voltage and  $-40$  to  $100^{\circ}\text{C}$  extended industrial temperature range
- High Speed
  - ◆ 20 Mbit/sec Data Rate (NRZ)
  - ◆ 55 ns max. Propagation Delay
  - ◆ 20 ns max. Pulse Width Distortion
- Safety and regulatory pending approvals
  - ◆ UL1577, 5,000 VAC<sub>RMS</sub> for 1 min.
  - ◆ DIN-EN/IEC60747-5-5, 1,140 V peak working insulation voltage for FOD8173T

### Typical Applications

- Microprocessor System Interface
  - ◆ SPI, I2C
- Industrial Field Bus Communications
  - ◆ DeviceNet, CAN, RS485
- Programmable Logic Control
- Isolated Data Acquisition System
- Voltage Level Translator



ON Semiconductor®

[www.onsemi.com](http://www.onsemi.com)



Stretched  
SOP 6 PINS

### MARKING DIAGRAM

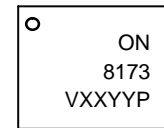

- ON = Corporate Name
- 8173 = Device Number
- V = DIN EN/IEC60747-5-5 Option
- XX = Two Digit Year Code
- YY = Digit Work Week
- P = Assembly Package Code

### PIN CONNECTIONS

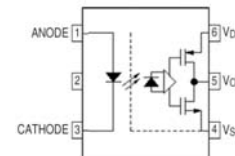

### TRUTH TABLE

LED	$V_{\text{O}}$
Off	High
On	Low

### ORDERING INFORMATION

See detailed ordering and shipping information on page 9 of this data sheet.

# FOD8173, FOD8173T

## SAFETY AND INSULATIONS RATING

As per DIN EN/IEC 60747-5-5, this optocoupler is suitable for “safe electrical insulation” only within the safety limit data. Compliance with the safety ratings shall be ensured by means of protective circuits.

**Table 1.**

Parameter		Characteristics	
		FOD8173	FOD8173T
Installation Classifications per DIN VDE 0110/1.89 Table 1, For Rated mains Voltage	< 150 VRMS	I-IV	I-IV
	< 300 VRMS	I-IV	I-IV
	< 450 VRMS	I-III	I-IV
	< 600 VRMS	I-III	I-III
Climatic Classification		40/100/21	40/100/21
Pollution Degree (DIN VDE 0110/1.89)		2	2
Comparative Tracking Index		175	175

**Table 2.**

Symbol	Parameter	Characteristics		Unit
		FOD8173	FOD8173T	
V <sub>PR</sub>	Input-to-Output Test Voltage, Method B, VIORM x 1.875 = VPR, 100% Production Test with tm = 1 s, Partial Discharge < 5 pC	1,671	2,137	Vpeak
	Input-to-Output Test Voltage, Method A, VIORM x 1.6 = VPR, Type and Sample Test with tm = 10 s, Partial Discharge < 5 pC	1,426	1,824	Vpeak
V <sub>IORM</sub>	Maximum Working Insulation Voltage	891	1,140	Vpeak
V <sub>IOTM</sub>	Highest Allowable Over-Voltage	6,000	8,000	Vpeak
	External Creepage	≥ 8.0	≥ 8.0	mm
	External Clearance	≥ 7.0	≥ 8.0	mm
DTI	Distance Through Insulation (Insulation Thickness)	≥ 0.4	≥ 0.4	mm
T <sub>S</sub>	Safety Limit Values – Maximum Values Allowed in the Event of a Failure, Case Temperature	150	150	°C
I <sub>S,INPUT</sub>	Input Current	200	200	mA
P <sub>S,OUTPUT</sub>	Output Power	300	300	mW
R <sub>IO</sub>	Insulation Resistance at T <sub>S</sub> , VIO = 500 V	>10 <sup>9</sup>	>10 <sup>9</sup>	Ω

# FOD8173, FOD8173T

**Table 3. ABSOLUTE MAXIMUM RATINGS (T<sub>A</sub> = 25°C unless otherwise specified)**

Symbol	Parameter	Value	Units
T <sub>STG</sub>	Storage Temperature	-40 to +125	°C
T <sub>OPR</sub>	Operating Temperature	-40 to +100	°C
T <sub>J</sub>	Junction Temperature	-40 to +125	°C
T <sub>SOL</sub>	Lead Solder Temperature (Refer to Reflow Temperature Profile)	260 for 10sec	°C
<b>Input Characteristics</b>			
I <sub>F</sub>	Average Forward Input Current	20	mA
V <sub>R</sub>	Reverse Input Voltage	5.0	V
P <sub>DI</sub>	Input Power Dissipation (Note 1)	40	mW
<b>Output Characteristics</b>			
V <sub>DD</sub>	Supply Voltage	0 to 6.0	V
V <sub>O</sub>	Output Voltage	-0.5 to V <sub>DD</sub> + 0.5	V
I <sub>O</sub>	Average Output Current	10	mA
P <sub>DO</sub>	Output Power Dissipation (Note 1)	70	mW

Stresses exceeding those listed in the Maximum Ratings table may damage the device. If any of these limits are exceeded, device functionality should not be assumed, damage may occur and reliability may be affected.

## RECOMMENDED OPERATING CONDITIONS

The Recommended Operating Conditions table defines the conditions for actual device operation. Recommended operating conditions are specified to ensure optimal performance to the datasheet specifications. ON Semiconductor does not recommend exceeding them or designing to Absolute Maximum Ratings.

**Table 4.**

Symbol	Parameter	Min.	Max.	Unit
T <sub>A</sub>	Ambient Operating Temperature	-40	+100	°C
V <sub>DD</sub>	Supply Voltages (Note 2)	3.0	5.5	V
V <sub>FL</sub>	Logic Low Input Voltage	0	0.8	V
I <sub>OL</sub>	Logic Low Output Current	0	7	mA
I <sub>FH</sub>	Logic High Input Current	5.0	16	mA

**Table 5. ISOLATION CHARACTERISTICS**

(Apply over all recommended conditions, typical value is measured at T<sub>A</sub> = 25°C)

Symbol	Parameter	Conditions	Min.	Typ.	Max.	Units
V <sub>ISO</sub>	Input-Output Isolation Voltage	T <sub>A</sub> = 25°C, R.H. < 50%, t = 1.0min, I <sub>I-O</sub> ≤ 20μA (Notes 3, 4)	5,000			V <sub>ACRMS</sub>
R <sub>ISO</sub>	Isolation Resistance	V <sub>I-O</sub> = 500V (Note 3)		10 <sup>11</sup>		Ω
C <sub>ISO</sub>	Isolation Capacitance	V <sub>I-O</sub> = 0V, freq=1.0Mhz (Note 3)		1.0		pF

1. No derating required to 100°C.
2. 0.1 μF bypass capacitor must be connected between 4 and 6.
3. Device is considered a two terminal device: Pins 1, 2 and 3 are shorted together and Pins 4, 5, and 6 are shorted together.
4. 5,000 V<sub>ACRMS</sub> for 1 minute duration is equivalent to 6,000 V<sub>ACRMS</sub> for 1 second duration.

# FOD8173, FOD8173T

**Table 6. ELECTRICAL CHARACTERISTICS**

(Apply over all recommended conditions,  $T_A = -40^{\circ}\text{C}$  to  $+100^{\circ}\text{C}$ ,  $3.0\text{V} \leq V_{DD} \leq 5.5\text{V}$ , unless otherwise specified. Typical value is measured at  $T_A = 25^{\circ}\text{C}$  and  $V_{DD} = 3.3\text{V}$ .)

Symbol	Parameter	Conditions	Min.	Typ.	Max.	Units
<b>INPUT CHARACTERISTICS</b>						
$V_F$	Forward Voltage	$I_F = 10\text{ mA}$	1.0	1.35	1.80	V
$BV_R$	Input Reverse Breakdown Voltage	$I_R = 10\ \mu\text{A}$	5.0	18		V
$I_{FHL}$	Threshold Input Current			2.8	5.0	mA
<b>OUTPUT CHARACTERISTICS</b>						
$V_{OL}$	Logic Low Output Voltage	$I_O = 20\ \mu\text{A}$ , $I_F = 10\text{ mA}$		0.0027	0.01	V
		$I_O = 4\text{ mA}$ , $I_F = 10\text{ mA}$		0.27	0.8	
$V_{OH}$	Logic High Output Voltage	$V_{DD} = 3.3\text{ V}$ , $I_O = -20\ \mu\text{A}$ , $I_F = 0\text{ mA}$	$V_{DD} - 0.1$	3.3		V
		$V_{DD} = 3.3\text{ V}$ , $I_O = -4\text{ mA}$ , $I_F = 0\text{ mA}$	$V_{DD} - 0.5$	3.1		
		$V_{DD} = 5.0\text{ V}$ , $I_O = -20\ \mu\text{A}$ , $I_F = 0\text{ mA}$	$V_{DD} - 0.1$	5.0		
		$V_{DD} = 5.0\text{ V}$ , $I_O = -4\text{ mA}$ , $I_F = 0\text{ mA}$	$V_{DD} - 0.5$	4.9		
$I_{DDL}$	Logic Low Output Supply Current	$I_F = 10\text{ mA}$ , $V_{DD} = 3.3\text{ V}$		3.3	4.8	mA
		$I_F = 10\text{ mA}$ , $V_{DD} = 5.0\text{ V}$		4.0	5.0	
$I_{DDH}$	Logic High Output Supply Current	$I_F = 0\text{ mA}$ , $V_{DD} = 3.3\text{ V}$		3.3	4.8	
		$I_F = 0\text{ mA}$ , $V_{DD} = 5.0\text{ V}$		4.0	5.0	

**Table 7. SWITCHING CHARACTERISTICS**

(Apply over all recommended conditions, ( $T_A = -40^{\circ}\text{C}$  to  $+100^{\circ}\text{C}$ ,  $3.0\text{V} \leq V_{DD} \leq 5.5\text{V}$ ,  $I_F = 5\text{ mA}$ ), unless otherwise specified. Typical value is measured at  $T_A = 25^{\circ}\text{C}$  and  $V_{DD} = 3.3\text{V}$ .)

Symbol	Parameter	Conditions	Min.	Typ.	Max.	Units
Date Rate (Note 5)					20	Mbit/sec
$t_{PW}$	Pulse Width		50			ns
$t_{PHL}$	Propagation Delay Time to Logic Low Output	$C_L = 15\text{ pF}$		25	55	ns
$t_{PLH}$	Propagation Delay Time to Logic High Output	$C_L = 15\text{ pF}$		25	55	ns
PWD	Pulse Width Distortion, $ t_{PHL} - t_{PLH} $	$C_L = 15\text{ pF}$		5.5	20	ns
$t_R$	Output Rise Time (10% – 90%)	$C_L = 15\text{ pF}$		7.0		ns
$t_F$	Output Fall Time (90% – 10%)	$C_L = 15\text{ pF}$		7.0		ns
$ CM_H $	Common Mode Transient Immunity at Output High	$I_F = 0\text{ mA}$ , $V_O > 0.8V_{DD}$ , $V_{CM} = 1000\text{V}$ , $T_A = 25^{\circ}\text{C}$ (Note 6)	20	40		kV/ $\mu\text{s}$
$ CM_L $	Common Mode Transient Immunity at Output Low	$I_F = 5\text{ mA}$ , $V_O < 0.8V_{DD}$ , $V_{CM} = 1000\text{V}$ , $T_A = 25^{\circ}\text{C}$ (Note 6)	20	40		kV/ $\mu\text{s}$

5. Data rate is based on 10 MHz, 50% NRZ pattern with a 50 nsec minimum bit time.

6. Common mode transient immunity at output high is the maximum tolerable positive  $dV_{cm}/dt$  on the leading edge of the common mode impulse signal,  $V_{cm}$ , to assure that the output will remain high. Common mode transient immunity at output low is the maximum tolerable negative  $dV_{cm}/dt$  on the trailing edge of the common pulse signal,  $V_{cm}$ , to assure that the output will remain low.

TYPICAL CHARACTERISTICS

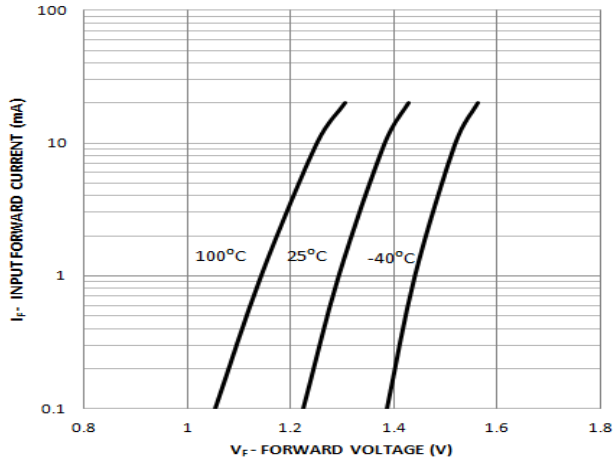

Figure 1. Input Forward Current vs. Forward Voltage

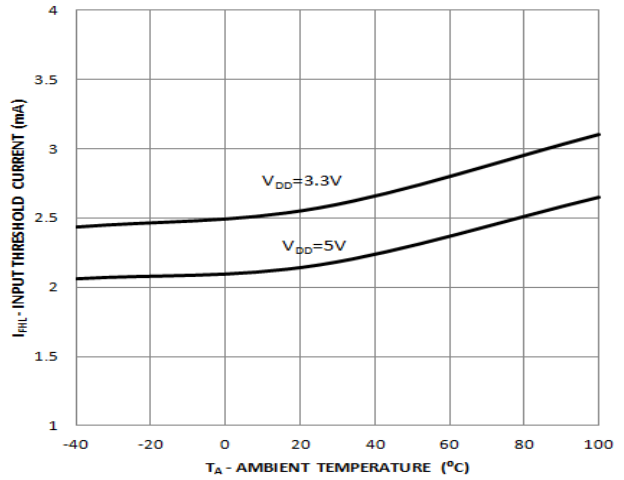

Figure 2. Input Threshold Current vs. Ambient Temperature

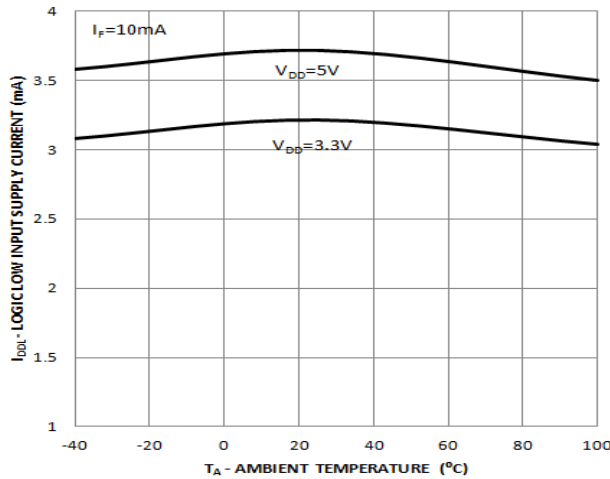

Figure 3. Logic Low Input Supply Current vs. Ambient Temperature

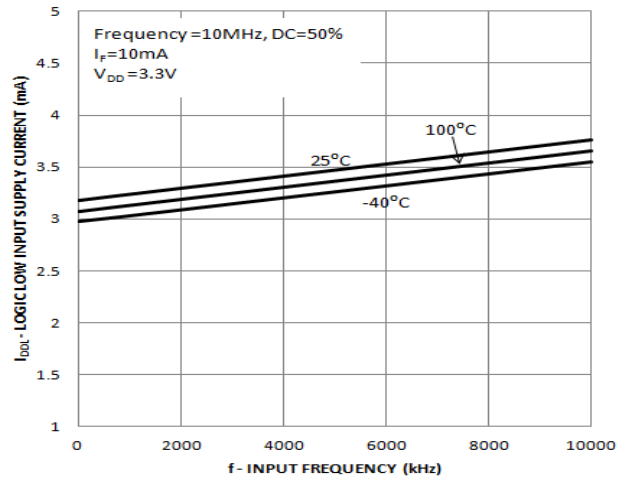

Figure 4. Logic Low Input Supply Current vs. Input Frequency ( $V_{DD} = 3.3 V$ )

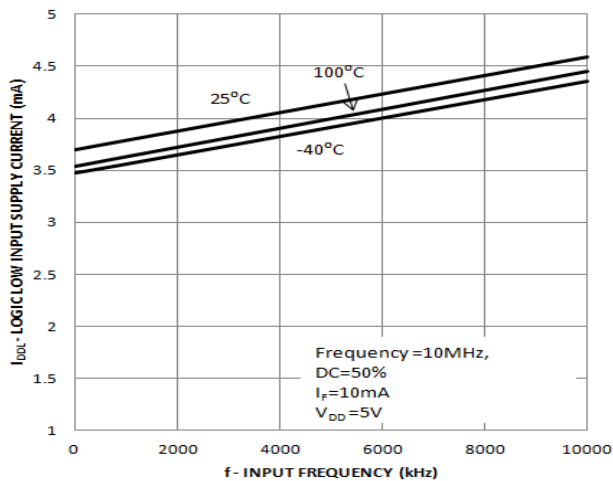

Figure 5. Logic Low Input Supply Current vs. Input Frequency ( $V_{DD} = 5 V$ )

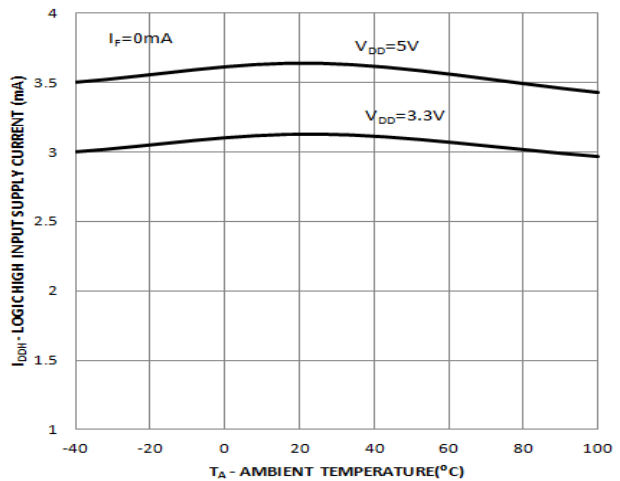

Figure 6. Logic High Input Supply Current vs. Ambient Temperature

# FOD8173, FOD8173T

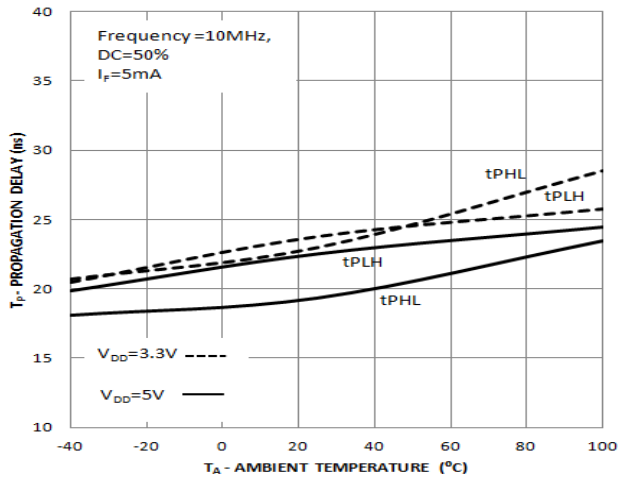

Figure 7. Propagation Delay vs. Ambient Temperature

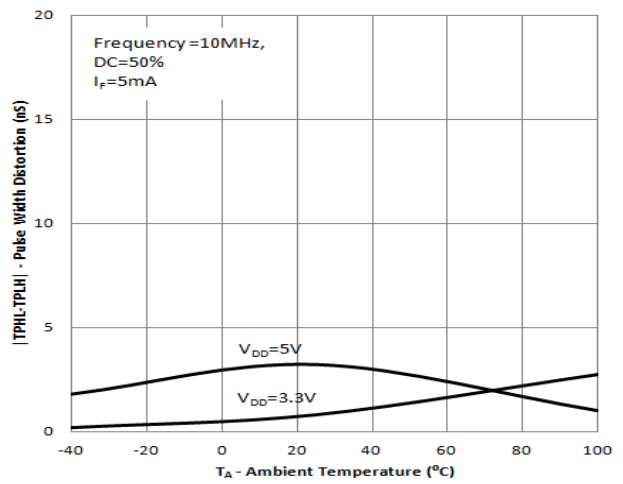

Figure 8. Pulse Width Distortion vs. Ambient Temperature

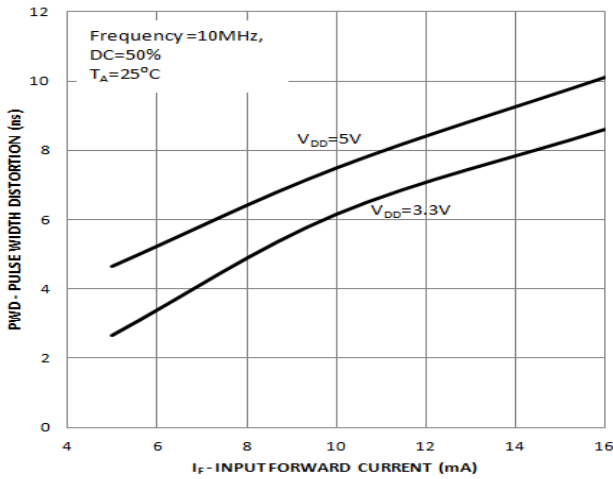

Figure 9. Pulse Width Distortion vs. Input Forward Current

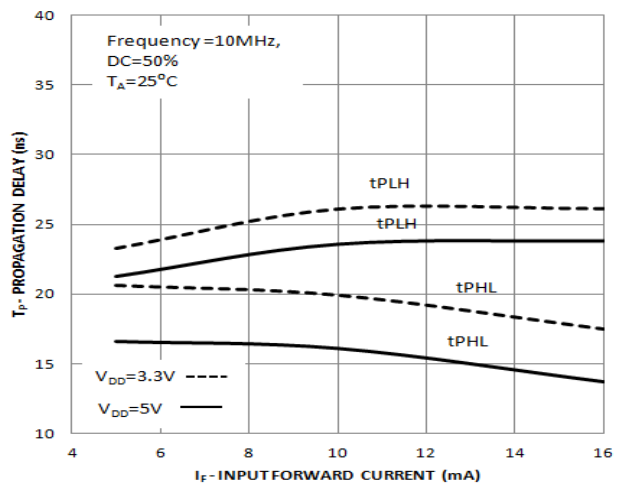

Figure 10. Propagation Delay vs. Input Forward Current

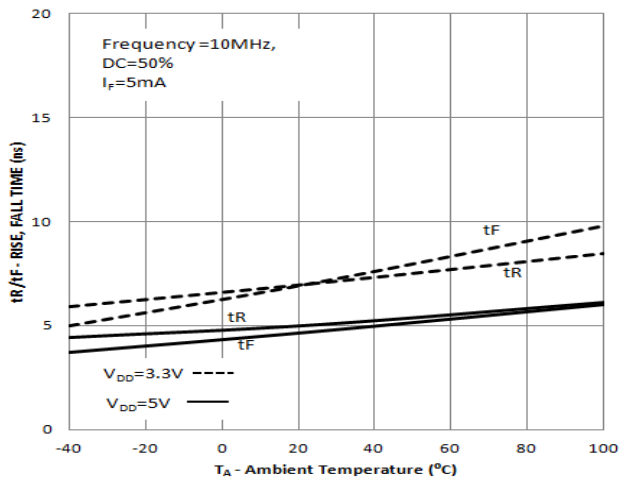

Figure 11. Rise, Fall Time vs. Ambient Temperature

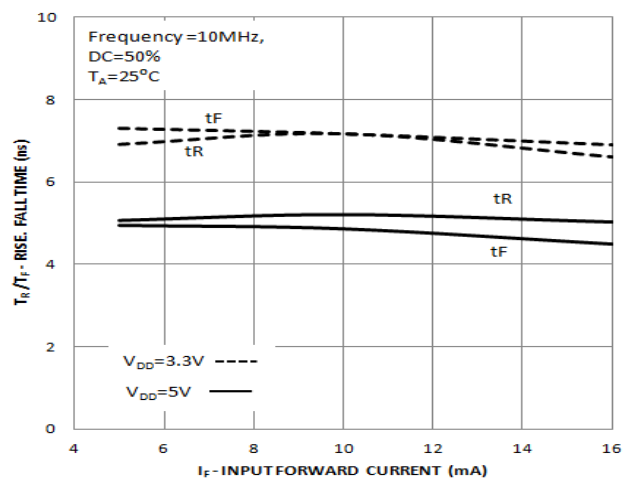

Figure 12. Rise, Fall Time vs. Input Forward Current

# FOD8173, FOD8173T

## SCHEMATICS

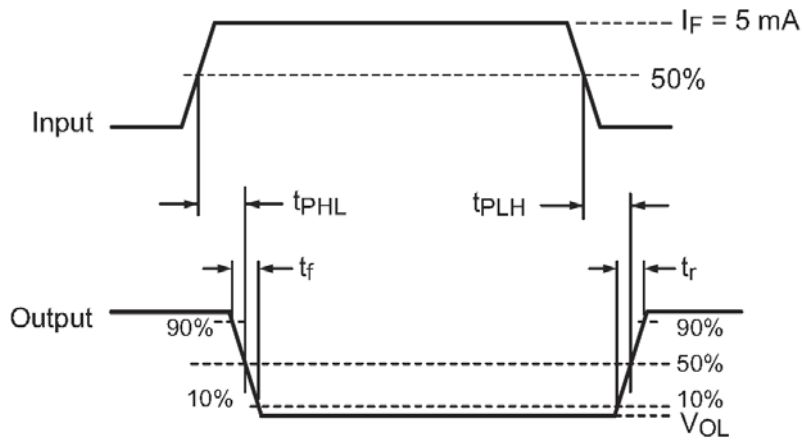
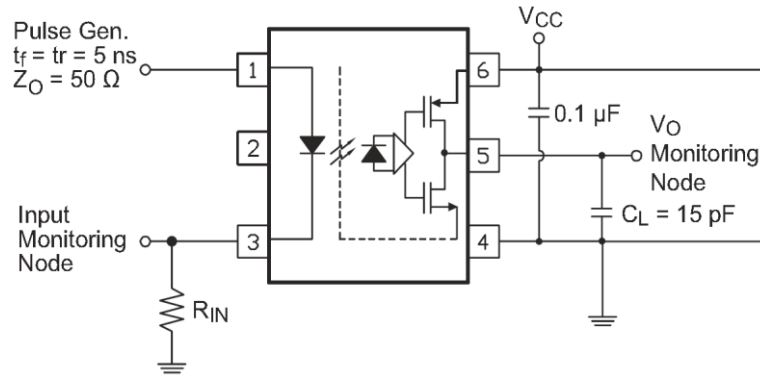

Figure 13. Test Circuit for Propagation Delay Time, Rise Time and Fall Time

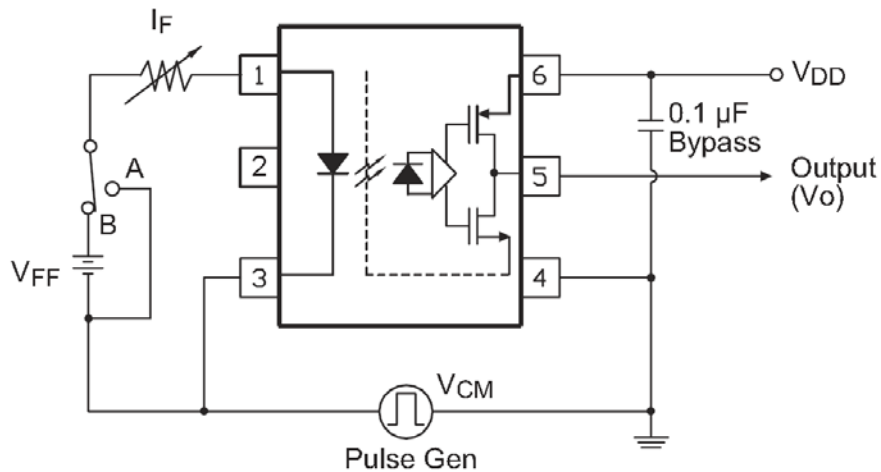

Figure 14. Test Circuit for Instantaneous Common Mode Rejection Voltage

REFLOW PROFILE

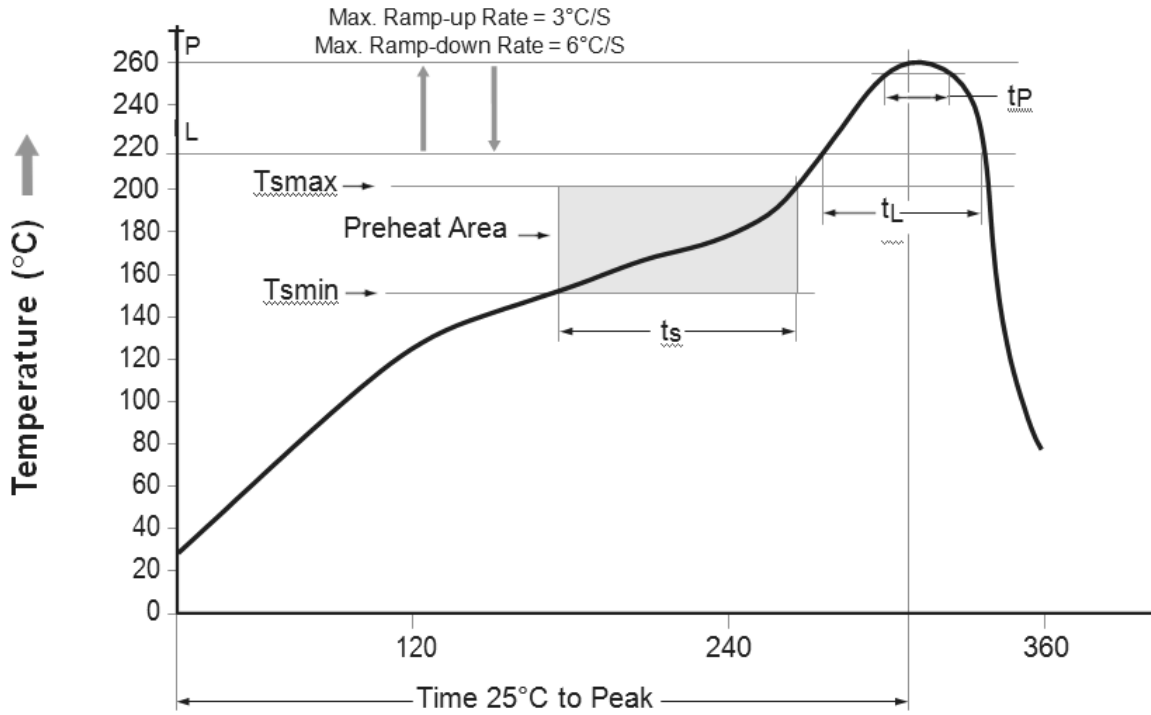

Figure 15. Reflow Profile

Table 8. REFLOW PROFILE

Profile Feature	Pb-Free Assembly Profile
Temperature Min. (T <sub>smín</sub> )	150°C
Temperature Max. (T <sub>smáx</sub> )	200°C
Time (t <sub>s</sub> ) from (T <sub>smín</sub> to T <sub>smáx</sub> )	60 – 120 seconds
Ramp-up Rate (t <sub>L</sub> to t <sub>P</sub> )	3°C/second max
Liquidous Temperature (TL)	217°C
Time (t <sub>L</sub> ) Maintained Above (TL)	60 – 150 seconds
Peak Body Package Temperature	260°C + 0°C / -5°C
Time (t <sub>P</sub> ) within 5°C of 260°C	30 seconds
Ramp-down Rate (TP to TL)	6°C / second max.
Time 25°C to Peak Temperature	8 minutes max.

# FOD8173, FOD8173T

**Table 9. ORDERING INFORMATION**

<b>Part Number</b>	<b>Package</b>	<b>Packing Method</b>
FOD8173	Stretched Body SOP 6–Pin	Tube (100 units per tube)
FOD8173R2	Stretched Body SOP 6–Pin	Tape and Reel (1,000 units per reel)
FOD8173V	Stretched Body SOP 6–Pin, DIN EN/IEC60747–5–5 Option (pending)	Tube (100 units per tube)
FOD8173R2V	Stretched Body SOP 6–Pin, DIN EN/ IEC60747–5–5 Option (pending)	Tape and Reel (1,000 units per reel)
FOD8173T	Stretched Body SOP 6–Pin, Wide Lead	Tube (100 units per tube)
FOD8173TR2	Stretched Body SOP 6–Pin, Wide Lead	Tape and Reel (1,000 units per reel)
FOD8173TV	Stretched Body SOP 6–Pin, Wide Lead, DIN EN/IEC60747–5–5 Option (pending)	Tube (100 units per tube)
FOD8173TR2V	Stretched Body SOP 6–Pin, Wide Lead, DIN EN/ IEC60747–5–5 Option (pending)	Tape and Reel (1,000 units per reel)

**MECHANICAL CASE OUTLINE**  
**PACKAGE DIMENSIONS**

ON Semiconductor®



**SOIC6 W**  
**CASE 751EM**  
**ISSUE O**

DATE 30 SEP 2016

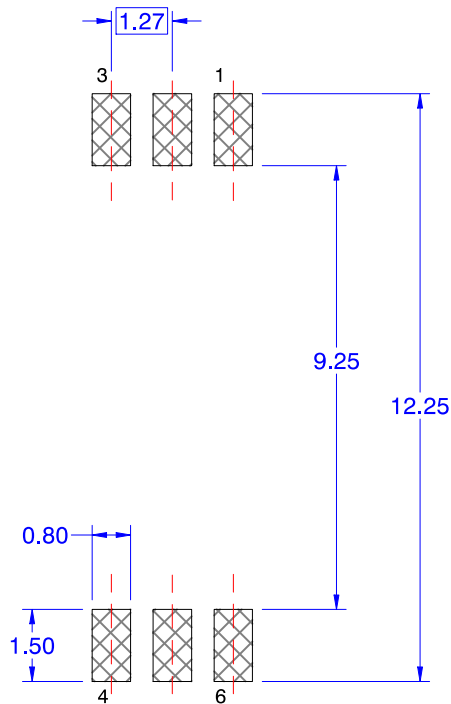
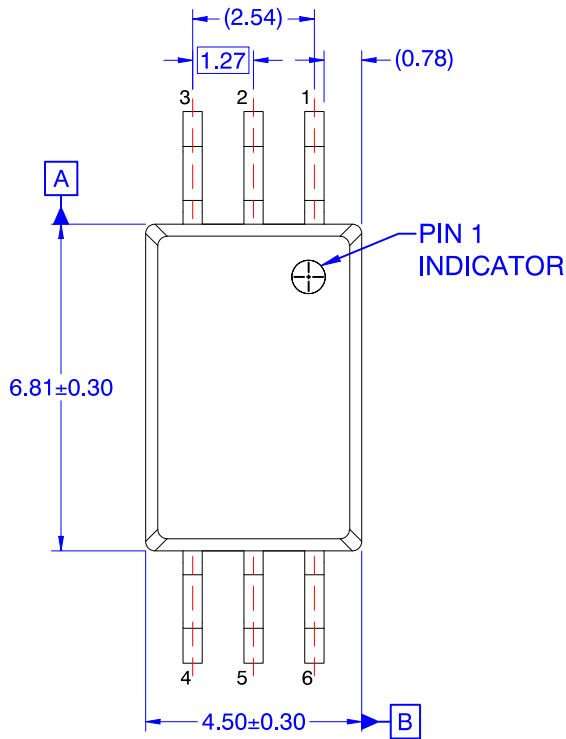

**RECOMMENDED LAND PATTERN**

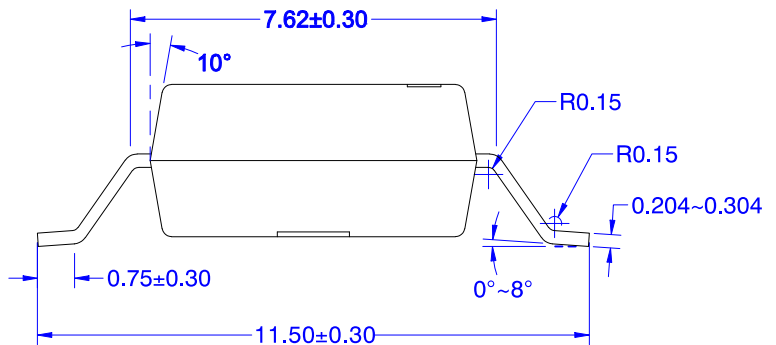
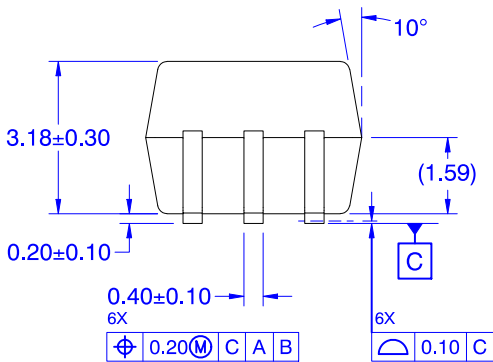

- NOTES: UNLESS OTHERWISE SPECIFIED**
- A) NO STANDARD APPLIES TO THIS PACKAGE
  - B) ALL DIMENSIONS ARE IN MILLIMETERS.
  - C) DIMENSIONS DO NOT INCLUDE BURRS OR MOLD FLASH, AND TIE BAR EXTRUSION.
  - D) DIMENSIONING AND TOLERANCING PER ASME Y14.5M-2009.

<b>DOCUMENT NUMBER:</b>	<b>98AON13749G</b>	Electronic versions are uncontrolled except when accessed directly from the Document Repository. Printed versions are uncontrolled except when stamped "CONTROLLED COPY" in red.
<b>DESCRIPTION:</b>	<b>SOIC6 W</b>	<b>PAGE 1 OF 1</b>

ON Semiconductor and are trademarks of Semiconductor Components Industries, LLC dba ON Semiconductor or its subsidiaries in the United States and/or other countries. ON Semiconductor reserves the right to make changes without further notice to any products herein. ON Semiconductor makes no warranty, representation or guarantee regarding the suitability of its products for any particular purpose, nor does ON Semiconductor assume any liability arising out of the application or use of any product or circuit, and specifically disclaims any and all liability, including without limitation special, consequential or incidental damages. ON Semiconductor does not convey any license under its patent rights nor the rights of others.

**onsemi**, **Onsemi**, and other names, marks, and brands are registered and/or common law trademarks of Semiconductor Components Industries, LLC dba "**onsemi**" or its affiliates and/or subsidiaries in the United States and/or other countries. **onsemi** owns the rights to a number of patents, trademarks, copyrights, trade secrets, and other intellectual property. A listing of **onsemi**'s product/patent coverage may be accessed at [www.onsemi.com/site/pdf/Patent-Marking.pdf](http://www.onsemi.com/site/pdf/Patent-Marking.pdf). **onsemi** reserves the right to make changes at any time to any products or information herein, without notice. The information herein is provided "as-is" and **onsemi** makes no warranty, representation or guarantee regarding the accuracy of the information, product features, availability, functionality, or suitability of its products for any particular purpose, nor does **onsemi** assume any liability arising out of the application or use of any product or circuit, and specifically disclaims any and all liability, including without limitation special, consequential or incidental damages. Buyer is responsible for its products and applications using **onsemi** products, including compliance with all laws, regulations and safety requirements or standards, regardless of any support or applications information provided by **onsemi**. "Typical" parameters which may be provided in **onsemi** data sheets and/or specifications can and do vary in different applications and actual performance may vary over time. All operating parameters, including "Typicals" must be validated for each customer application by customer's technical experts. **onsemi** does not convey any license under any of its intellectual property rights nor the rights of others. **onsemi** products are not designed, intended, or authorized for use as a critical component in life support systems or any FDA Class 3 medical devices or medical devices with a same or similar classification in a foreign jurisdiction or any devices intended for implantation in the human body. Should Buyer purchase or use **onsemi** products for any such unintended or unauthorized application, Buyer shall indemnify and hold **onsemi** and its officers, employees, subsidiaries, affiliates, and distributors harmless against all claims, costs, damages, and expenses, and reasonable attorney fees arising out of, directly or indirectly, any claim of personal injury or death associated with such unintended or unauthorized use, even if such claim alleges that **onsemi** was negligent regarding the design or manufacture of the part. **onsemi** is an Equal Opportunity/Affirmative Action Employer. This literature is subject to all applicable copyright laws and is not for resale in any manner.

## ADDITIONAL INFORMATION

### TECHNICAL PUBLICATIONS:

Technical Library: [www.onsemi.com/design/resources/technical-documentation](http://www.onsemi.com/design/resources/technical-documentation)  
onsemi Website: [www.onsemi.com](http://www.onsemi.com)

### ONLINE SUPPORT: [www.onsemi.com/support](http://www.onsemi.com/support)

For additional information, please contact your local Sales Representative at [www.onsemi.com/support/sales](http://www.onsemi.com/support/sales)



## Looking for pricing, stock, or lifecycle information?

Click below to explore more details on WIN SOURCE:

 [View FOD8173](#) on WIN SOURCE

 [ON Semiconductor](#) Information

## Optimize Your Supply Chain with WIN SOURCE Solutions

-  Global Sourcing Solution
-  Obsolete Management
-  Cost Control Management
-  Shortage Management
-  Alternative Solution
-  Excess Inventory Management