

ASMT- Mx2x / ASMT- MxEx Moonstone™ 3W Power LED Light Source



Data Sheet



Description

The Moonstone™ 3W Power LED Light Source is a high performance energy efficient device which can handle high thermal and high driving current. The exposed pad design has excellent heat transfer from the package to the motherboard.

The Cool White Power LED is available in various color temperature ranging from 4000K to 10000K and Warm White Power LED ranging from 2600K to 4000K.

The low profile package design is suitable for a wide variety of applications especially where height is a constraint.

The package is compatible with reflow soldering. This will give more freedom and flexibility to the light source designer.

Applications

- Sign backlight
- Safety, exit and emergency sign lightings
- Specialty lighting such as task lighting and reading lights
- Retail display
- Commercial lighting
- Accent or marker lightings, strip or step lightings
- Portable lightings, bicycle head lamp, torch lights.
- Decorative lighting
- Architectural lighting
- Pathway lighting
- Street lighting
- Pedestrian street lighting
- Tunnel lighting

Features

- Available in Cool White & Warm White color
- Energy efficient
- Exposed pad for excellent heat transfer
- Suitable for reflow soldering process
- High current operation
- Long operation life
- Wide viewing angle
- Silicone encapsulation
- Non-ESD sensitive (threshold > 16KV)
- MSL 4 products
- Available in both electrically isolated and non-isolated metal heat slug

Specifications

- InGaN Technology
- 4.3 V (max) at 700 mA
- 120° viewing angle

Package Dimensions

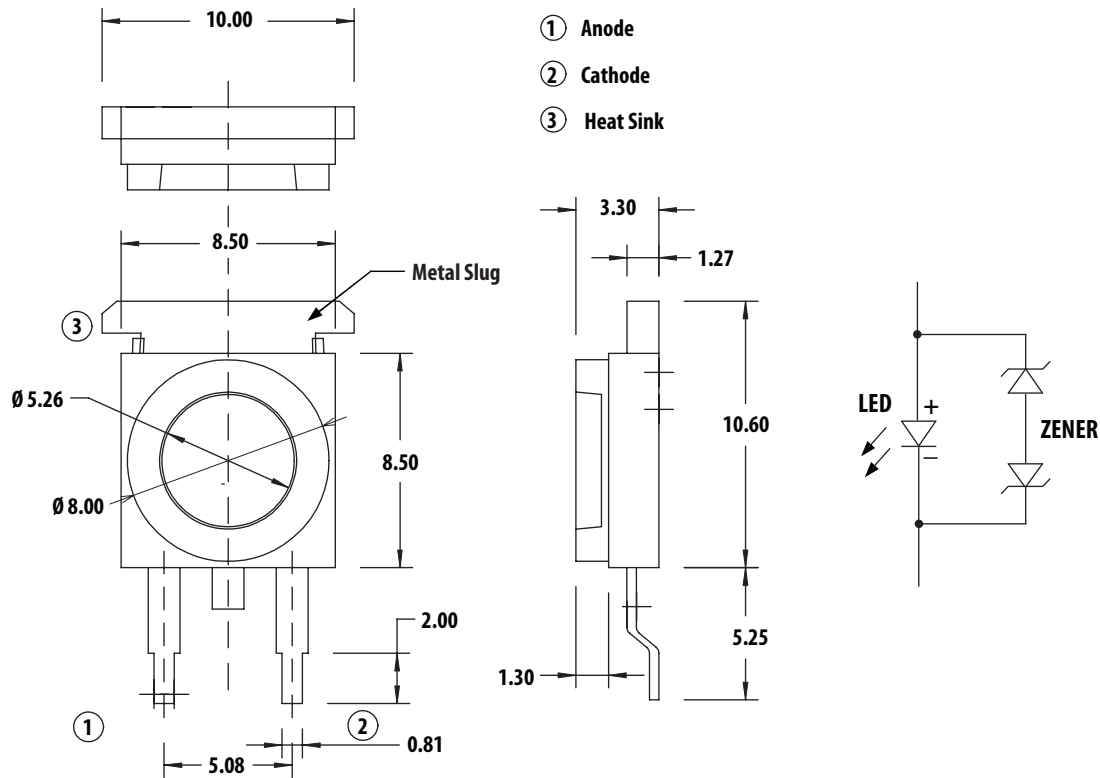

Notes:

1. All dimensions are in millimeters.
2. Unless otherwise stated, the tolerance for dimension is ± 0.1 mm.
3. Metal slug is connected to anode for electrically non-isolated option.

Device Selection Guide ($T_J = 25^\circ\text{C}$)

Color	Part Number	Luminous Flux, $\Phi_V^{[1,2]}$ (lm)			Test Current (mA)	Die Technology	Electrically Isolated Metal Slug
		Min.	Typ.	Max.			
Cool White	ASMT-MW20	124	145	161	700	InGaN	No
	ASMT-MW22						Yes
Warm White	ASMT-MY20	95	125	161	700	InGaN	No
	ASMT-MY22						Yes
Cool White Diffused	ASMT-MWE0	95	125	161	700	InGaN	No
	ASMT-MWE2						Yes
Warm White Diffused	ASMT-MYE0	95	110	161	700	InGaN	No
	ASMT-MYE2						Yes

Notes:

1. Φ_V is the total luminous flux output as measured with an integrating sphere at 25ms mono pulse condition.
2. Flux tolerance is $\pm 10\%$.

Part Numbering System

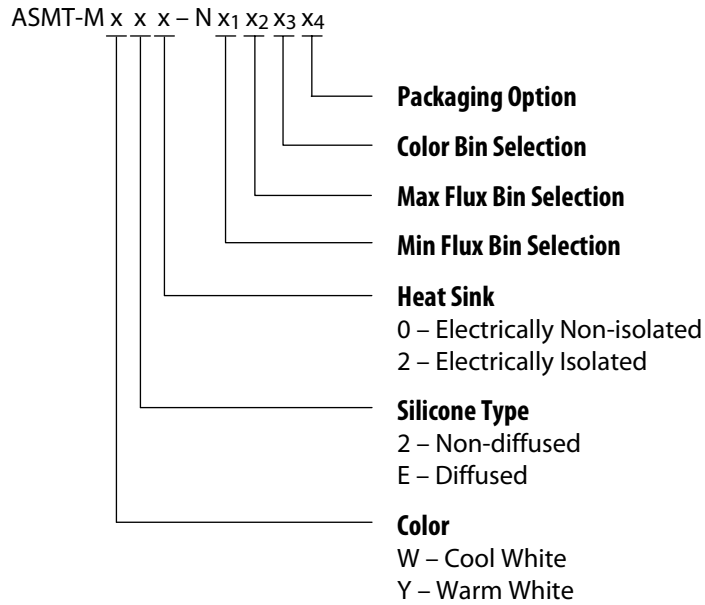

Note:

1. Please refer to Page 7 for selection details.

Absolute Maximum Ratings

Parameter	ASMT-Mx2x / ASMT-MxEx	Units
DC Forward Current ^[1]	700	mA
Peak Pulsing Current ^[2]	1000	mA
Power Dissipation	3010	mW
Reverse Voltage	5	V
LED Junction Temperature	125	°C
Operating Metal Slug Temperature Range at 700mA	-40 to +95	°C
Storage Temperature Range	-40 to +120	°C
Soldering Temperature	Refer to Figure 8	

Note:

1. Derate linearly based on Figure 6.
2. Pulse condition: duty factor = 10%, Frequency = 1 kHz.

Optical Characteristics at 700 mA ($T_J = 25^\circ\text{C}$)

Part Number	Color	Correlated Color Temperature, CCT (Kelvin)		Viewing Angle $2\theta_{1/2}$ ^[1] (°)	Luminous Efficiency (lm/W)
		Min.	Max.	Typ.	Typ.
ASMT-MW20 ASMT-MW22	Cool White	4000	10000	120	52
ASMT-MY20 ASMT-MY22	Warm White	2600	4000	120	45
ASMT-MWE0 ASMT-MWE2	Cool White Diffused	4000	10000	120	45
ASMT-MYE0 ASMT-MYE2	Warm White Diffused	2600	4000	120	41

Notes:

- $\theta_{1/2}$ is the off-axis angle where the luminous intensity is $1/2$ the peak intensity.

Electrical Characteristic at 700 mA ($T_J = 25^\circ\text{C}$)

Dice Type	Forward Voltage, V_F (Volts) at $I_F = 700$ mA			Thermal Resistance, $R\theta_{j-ms}$ ($^\circ\text{C}/\text{W}$) ^[1]	Temperature Coefficient of Forward Voltage ($\text{mV}/^\circ\text{C}$), $\Delta V_F/\Delta T_J$
	Min.	Typ.	Max.	Typ.	Typ.
InGaN	3.6	4.0	4.3	10	-1.5 to -3.5

Note:

- $R\theta_{j-ms}$ is the Thermal Resistance from LED junction to metal slug.

Typical Characteristic at 350 mA ($T_J = 25^\circ\text{C}$)

Part Number	Color	Luminous Flux, Φ_V (lm)	Forward Voltage, V_F (Volts)
		Typ.	Typ.
ASMT-MW20 ASMT-MW22	Cool White	80	3.6
ASMT-MY20 ASMT-MY22	Warm White	70	3.6
ASMT-MWE0 ASMT-MWE2	Cool White Diffused	70	3.6
ASMT-MYE0 ASMT-MYE2	Warm White Diffused	65	3.6

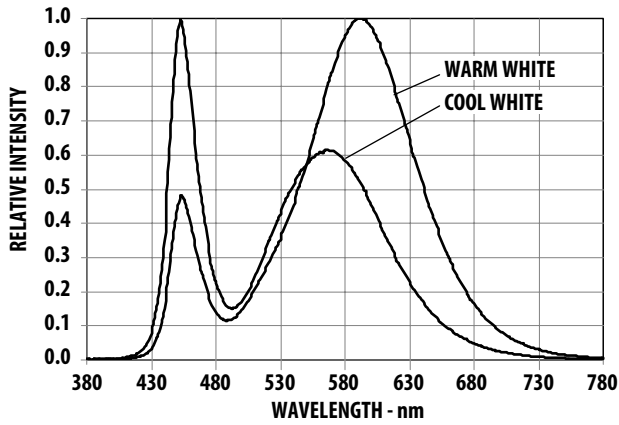

Figure 1. Relative Intensity vs. Wavelength.

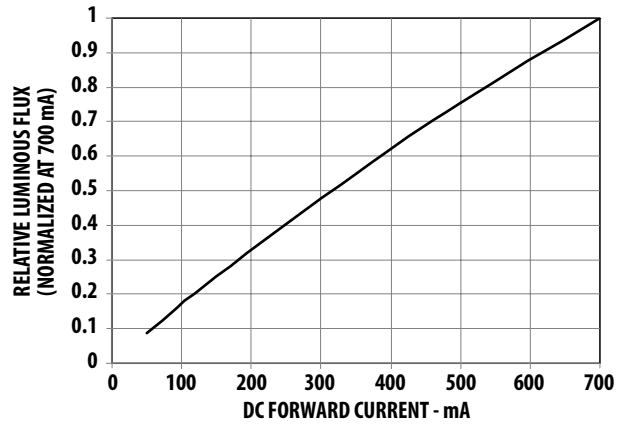

Figure 2. Relative Luminous Flux vs. Forward Current.

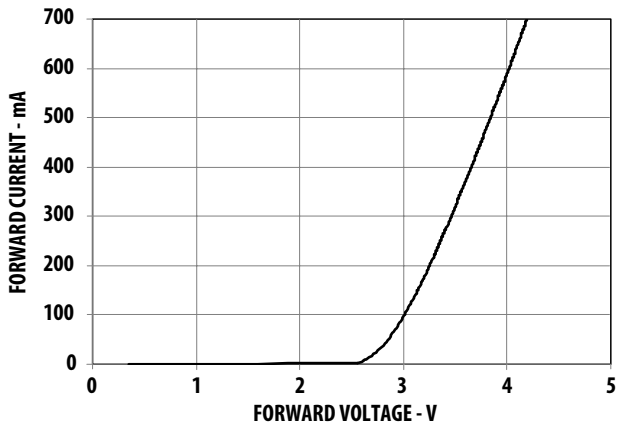

Figure 3. Forward Current vs. Forward Voltage.

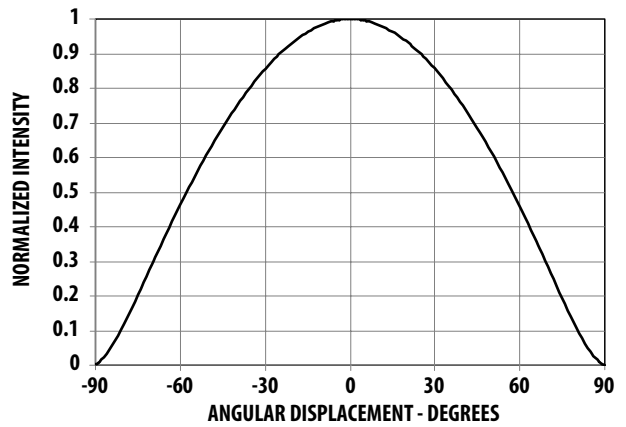

Figure 4. Radiation Pattern.

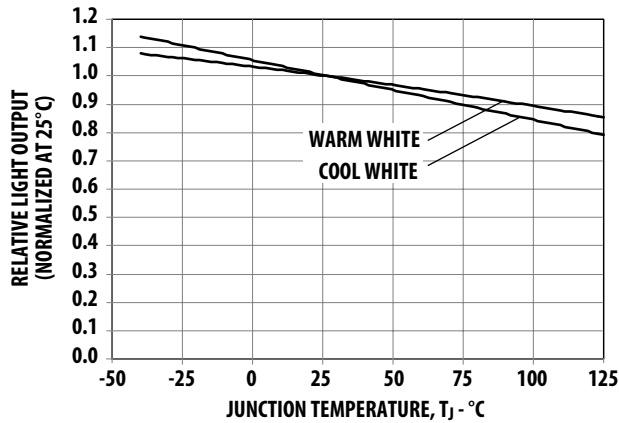

Figure 5. Relative Light Output vs. Junction Temperature.

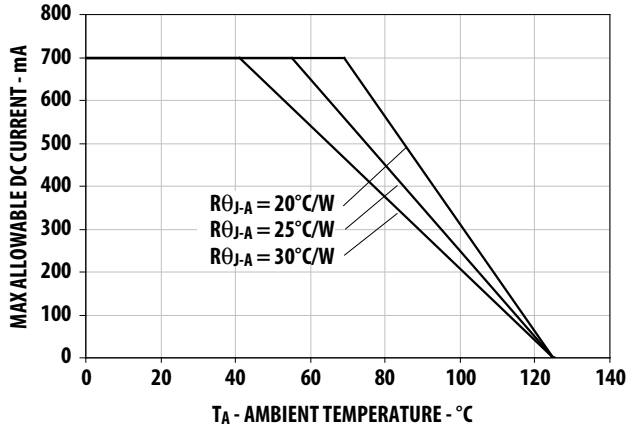

Figure 6. Maximum Forward Current vs. Ambient Temperature. Derated based on $T_{JMAX} = 125^{\circ}\text{C}$, $R_{\theta J-A} = 20^{\circ}\text{C/W}$, 25°C/W and 30°C/W .

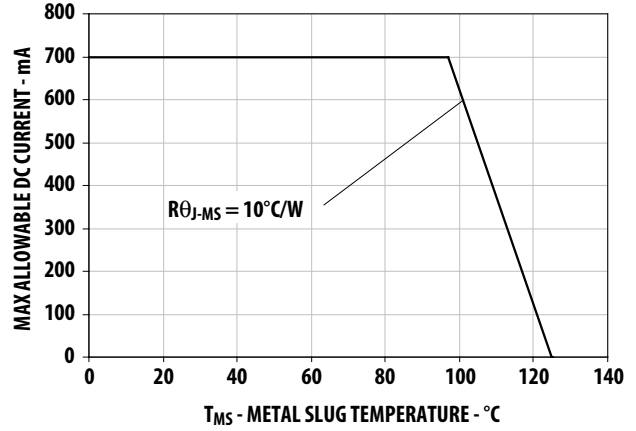

Figure 7. Maximum Forward Current vs. Metal Slug Temperature. Derated based on $T_{JMAX} = 125^{\circ}\text{C}$, $R_{\theta J-MS} = 10^{\circ}\text{C/W}$.

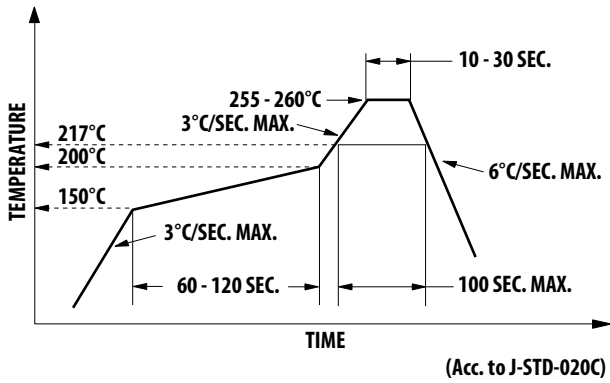

Figure 8. Recommended Reflow Soldering. (Acc. to J-STD-020C)

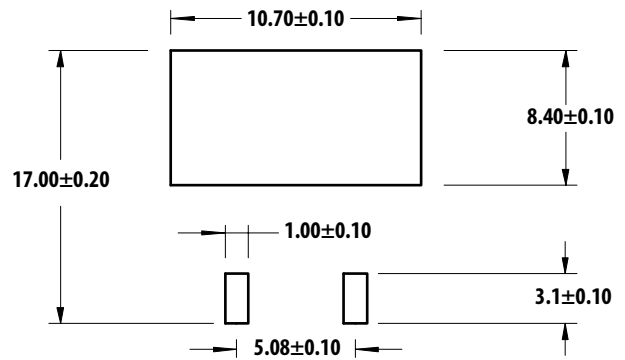

Figure 9. Recommended soldering land pattern.

Option Selection Details

ASMT-Mxxx – N x₁ x₂ x₃ x₄

x₁ – Minimum Flux Bin

x₂ – Maximum Flux Bin

x₃ – Color Bin Selection

x₄ – Packaging Option

Color Bin Selections [x₃]

Individual reel will contain parts from one full bin only.

Cool White

0	Full Distribution
A	A only
B	B only
C	C only
D	D only
E	E only
F	F only
G	G only
H	H only
L	A and G only
M	B and H only
N	A and C only
P	B and D only
Q	E and C only
R	F and D only
S	G and H only
U	E and F only
W	C and D only
Z	A and B only
1	A, B, C and D only
2	G, H, A and B only
4	C, D, E and F only

Flux Bin Limit [x₁ x₂]

Bin	Luminous Flux (lm) at I_F = 700mA	
	Min.	Max.
L	73.0	95.0
M	95.0	124.0
N	124.0	161.0

Tolerance for each bin limits is ±10%.

Warm White

0	Full Distribution
A	A only
B	B only
C	C only
D	D only
E	E only
F	F only
N	A and C only
P	B and D only
Q	E and C only
R	F and D only
U	E and F only
W	C and D only
Z	A and B only
V	D and E only
1	A, B, C and D only
4	C, D, E and F only

Color Bin Limit

Cool White	Color Limits (Chromaticity Coordinates)	Color Limits (Chromaticity Coordinates)			
		X	Y	X	Y
Bin A	X	0.367	0.362	0.329	0.329
	Y	0.400	0.372	0.345	0.369
Bin B	X	0.362	0.356	0.329	0.329
	Y	0.372	0.330	0.302	0.345
Bin C	X	0.329	0.329	0.305	0.301
	Y	0.369	0.345	0.322	0.342
Bin D	X	0.329	0.329	0.311	0.305
	Y	0.345	0.302	0.285	0.322
Bin E	X	0.303	0.307	0.283	0.274
	Y	0.333	0.311	0.284	0.301
Bin F	X	0.307	0.311	0.290	0.283
	Y	0.311	0.285	0.265	0.284
Bin G	X	0.388	0.379	0.362	0.367
	Y	0.417	0.383	0.372	0.400
Bin H	X	0.379	0.369	0.356	0.362
	Y	0.383	0.343	0.330	0.372

Tolerance: ± 0.01

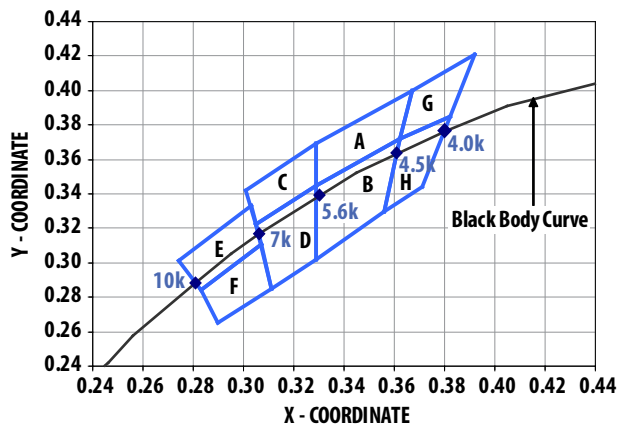

Figure 10a. Color bins (Cool White).

Warm White	Color Limits (Chromaticity Coordinates)	Color Limits (Chromaticity Coordinates)			
		X	Y	X	Y
Bin A	X	0.452	0.488	0.470	0.438
	Y	0.434	0.447	0.414	0.403
Bin B	X	0.438	0.470	0.452	0.424
	Y	0.403	0.414	0.384	0.376
Bin C	X	0.407	0.418	0.452	0.438
	Y	0.393	0.422	0.434	0.403
Bin D	X	0.395	0.407	0.438	0.424
	Y	0.362	0.393	0.403	0.376
Bin E	X	0.381	0.387	0.418	0.407
	Y	0.377	0.404	0.422	0.393
Bin F	X	0.373	0.381	0.407	0.395
	Y	0.349	0.377	0.393	0.362

Tolerance: ± 0.01

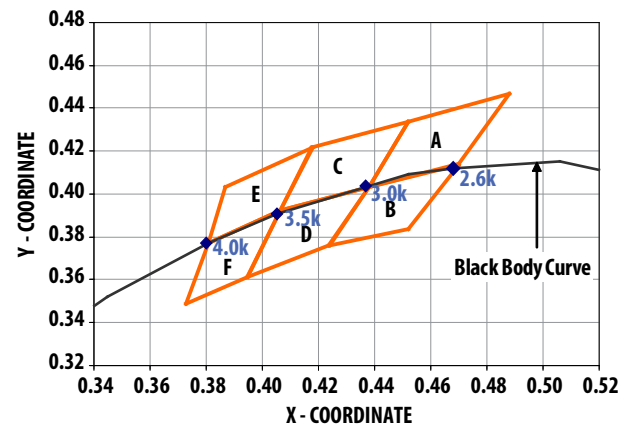

Figure 10b. Color bins (Warm White).

Packaging Option [x₄]

Selection	Option
0	Tube
1	Tape and Reel

Example

ASMT-MW20-NLNZO

ASMT-MW20-Nxxxx – Cool White, Electrically Non-isolated Heat Sink, Non-diffused

- X₁ = L – Minimum Flux Bin L
- X₂ = N – Maximum Flux Bin N
- X₃ = Z – Color Bin A and B only
- X₄ = 0 – Tube Option

Packing Tube – Option 0

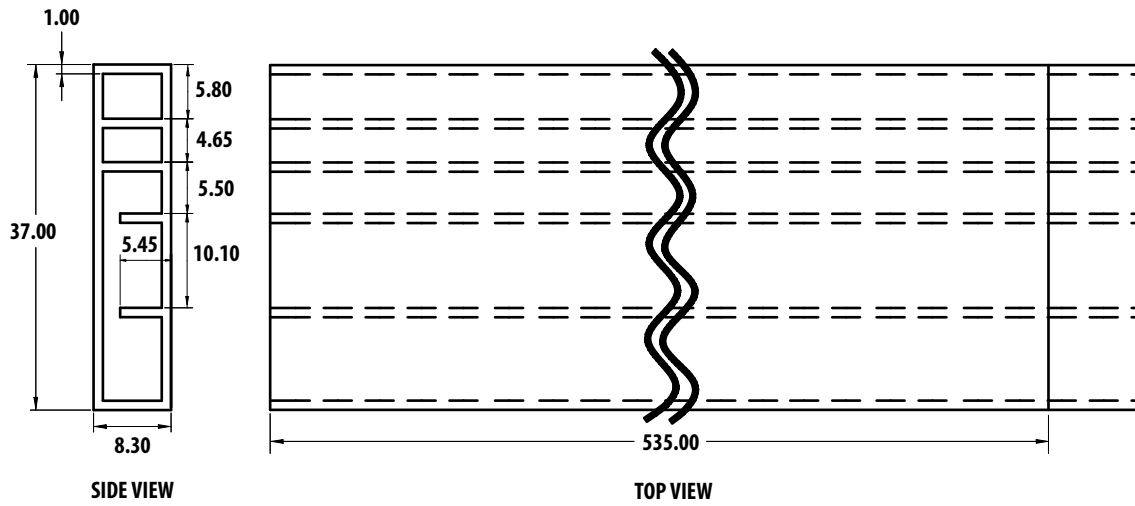
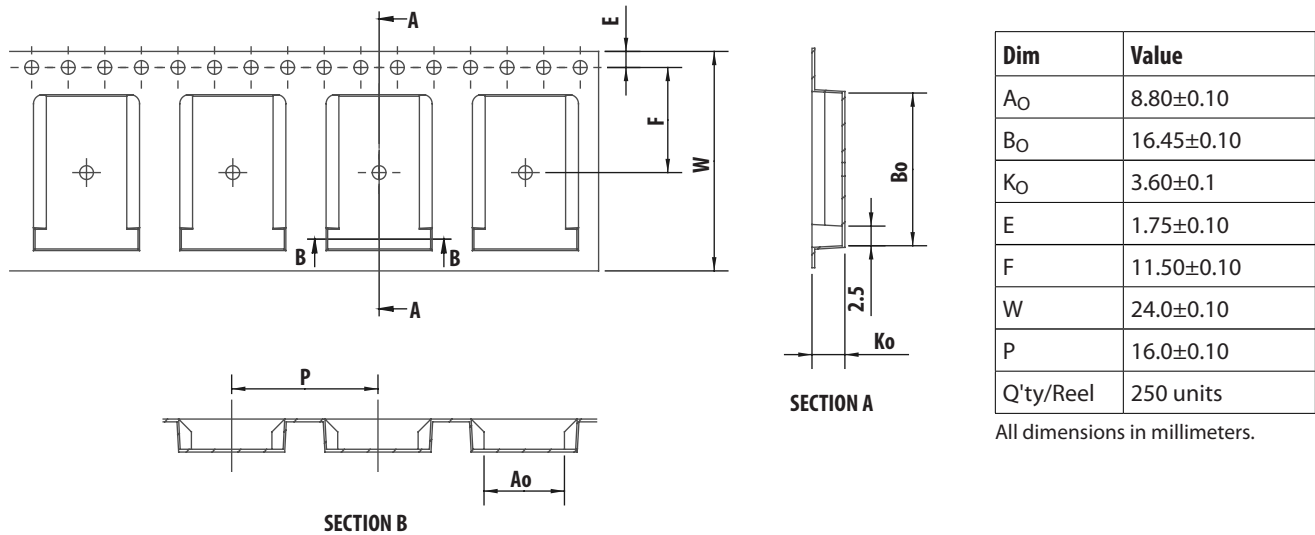

Figure 11. Tube dimensions

Tape & Reel – Option 1



All dimensions in millimeters.

Figure 12. Carrier tape dimensions

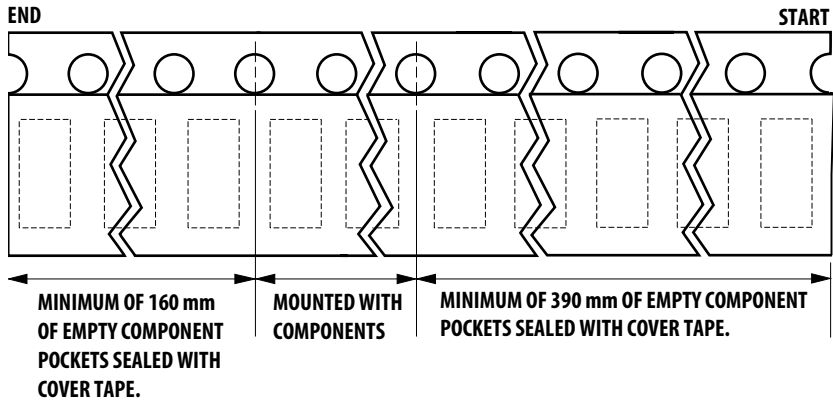

Figure 13. Carrier tape leader and trailer dimensions.

Reel Dimension

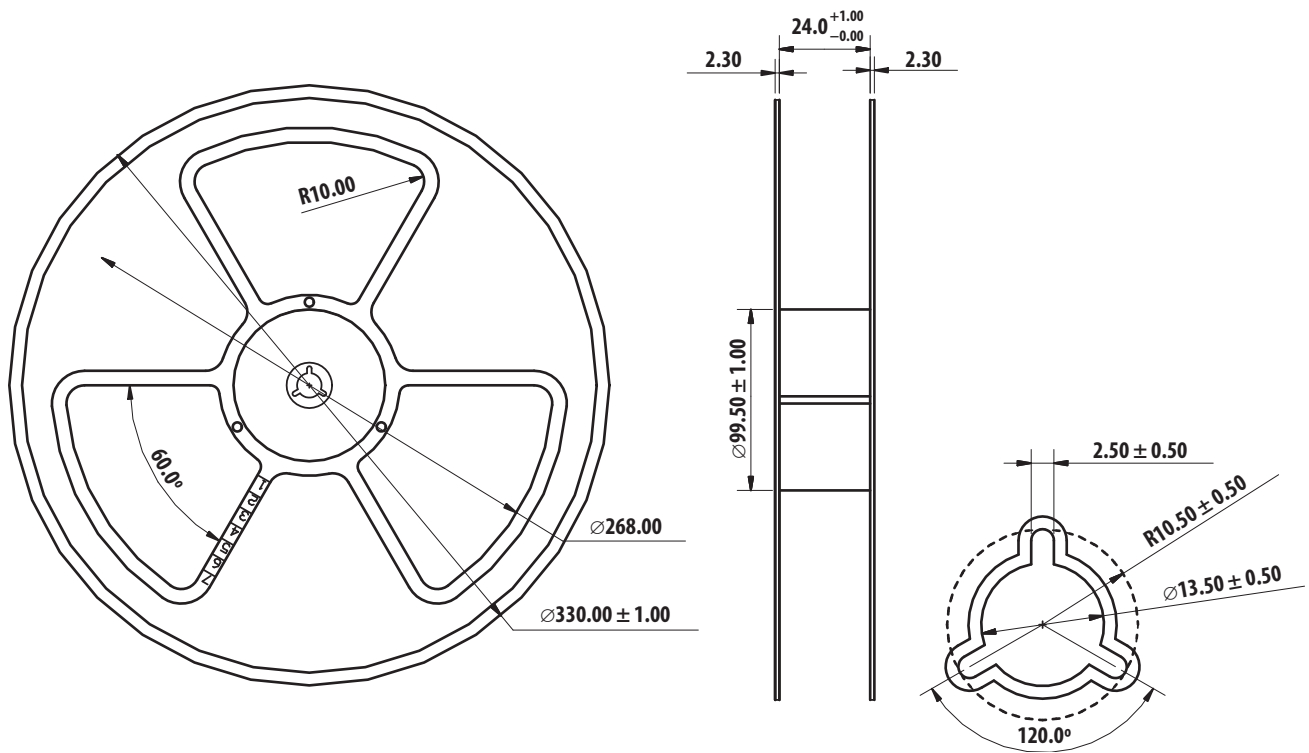

Figure 14. Reel dimensions.

Handling Precaution

The encapsulation material of the product is made of silicone for better reliability of the product. As silicone is a soft material, please do not press on the silicone or poke a sharp object onto the silicone. These might damage the product and cause premature failure. During assembly or handling, the unit should be held on the body only. Please refer to Avago Application Note AN 5288 for detail information.

Moisture Sensitivity

This product is qualified as Moisture Sensitive Level 4 per Jedec J-STD-020. Precautions when handling this moisture sensitive product is important to ensure the reliability of the product. Do refer to Avago Application Note AN5305 Handling of Moisture Sensitive Surface Mount Devices for details.

A. Storage before use

- Unopen moisture barrier bag (MBB) can be stored at $40^{\circ}\text{C}/90\%RH$ for 12 months. If the actual shelf life has exceeded 12 months and the humidity indicator card (HIC) indicates that baking is not required, then it is safe to reflow the LEDs per the original MSL rating.
- It is not recommended to open the MBB prior to assembly (e.g. for IQC).

B. Control after opening the MBB

- The humidity indicator card (HIC) shall be read immediately upon opening of MBB.
- The LEDs must be kept at $30^{\circ}\text{C}/60\%RH$ at all time and all high temperature related process including soldering, curing or rework need to be completed within 72 hours.

C. Control for unfinished reel

- For any unused LEDs, they need to be stored in sealed MBB with desiccant or desiccator at $5\%RH$.

D. Control of assembly boards

- If the PCB soldered with the LEDs is to be subjected to other high temperature processes, the PCB need to be stored in sealed MBB with desiccant or desiccator at $5\%RH$ to ensure no LEDs have exceeded their floor life of 72 hours.

E. Baking is required if

- HIC "10%" indicator is not blue and "5%" indicator is pink.
- The LEDs are exposed to condition of $30^{\circ}\text{C}/60\%RH$ at any time.
- The LEDs floor life exceeded 72hrs.

Recommended baking condition: $60\pm 5^{\circ}\text{C}$ for 20hrs.

DISCLAIMER: Avago's products and software are not specifically designed, manufactured or authorized for sale as parts, components or assemblies for the planning, construction, maintenance or direct operation of a nuclear facility or for use in medical devices or applications. Customer is solely responsible, and waives all rights to make claims against avago or its suppliers, for all loss, damage, expense or liability in connection with such use.

For product information and a complete list of distributors, please go to our web site: www.avagotech.com

Avago, Avago Technologies, and the A logo are trademarks of Avago Technologies in the United States and other countries. Data subject to change. Copyright © 2005-2009 Avago Technologies. All rights reserved. AV02-1452EN - April 3, 2009

AVAGO
TECHNOLOGIES

Looking for pricing, stock, or lifecycle information?

Click below to explore more details on WIN SOURCE:

- ⊖ [View ASMT-MW22-NNN00 on WIN SOURCE](#)
- ⊖ [Broadcom Limited Information](#)

Optimize Your Supply Chain with WIN SOURCE Solutions

- ✓ Global Sourcing Solution
- ✓ Obsolete Management
- ✓ Cost Control Management
- ✓ Shortage Management
- ✓ Alternative Solution
- ✓ Excess Inventory Management