

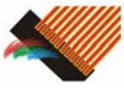

THE DATASHEET OF 913





JINWANG

PRODUCT SPECIFICATION

MODEL: JW035PD01

VERSION: 1.0

ISSUED DATE: 10/26/2006

CUSTOMER'S APPROVAL	
BY	
DATE	

JING WANG OPTOELECTRONICS CO., LTD.	
PREPARED BY	DATE
APPROVED BY	DATE

Note:

1. **JINWANG OPTOELECTRONICS CO., LTD** reserves the right to make changes without further notice to any products herein to improve reliability, function or design.
2. All rights are reserved. No one is permitted to reproduce or duplicate the whole or part of this document without permission of **JINWANG OPTOELECTRONICS CO., LTD.**

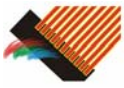

Record of Revisions

Rev.	Date	Description of change
1.0	Oct.26, 2006	JW035PD01 specification was first issued.

1. OVERVIEW

CLAA035QVA01 is 3.5" (8.76cm) color TFT-LCD (Thin Film Transistor Liquid Crystal Display) module composed of LCD panel, driver ICs , control circuit , and backlight.

The 3.5" screen produces 320 ×RGB×240 resolution image. By applying 8 bits digital data, 16.7 million color images are displayed on the 3.5" diagonal screen. The Driver for LED backlight is not included in this module.

General specifications are summarized in the following table:

ITEM	ECIFICATION
Display Area (mm)	70.08(W) x 52.56(H)
Number of Pixels	320 ×3(H) ×240(V)
Pixel Pitch (mm)	0.219(H) ×0.219(V)
Color Pixel Arrangement	RGB vertical strip
Display Mode	Normally White
Number of color	16.7M
Viewing Direction	6 o'clock
Brightness(cd/m ²)	250(typ)
Viewing Angle CR ≥ 10	120 degree (H) , 100 degree (V)
Electrical Interface	Digital 24bits RGB
Power Consumption(W)	0.43 (Typ.)
Outline Dimension (mm)	76.9(H) × 63.9(V) × 3.3(D)
weight(g)	34g
BL unit	6pcs LED
Surface Treatment	Anti-Glare , Surface hardness: 3H

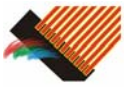

2. ABSOLUTE MAXIMUM RATINGS

The following values are maximum operation conditions. If exceeded, it may cause faulty operation or damage.

(GND=AVSS=0V)

ITEM	SYMBOL	MIN.	MAX.	UNIT	NOTE
Power Supply Voltage for Digital	VCC	-0.3	4	V	
Power Supply Voltage for Analog	AVDD	-0.3	7	V	
Gate On Voltage	VGH	-0.3	25	V	
Gate Off Voltage	VGL	-15	0.3	V	
Static Electricity	VESDc	-200	200	V	Note1
	VESDm	-15	15	KV	
LED forward current	If		30	mA	Note2
LED pulse forward current	Ip		100	mA	
LED reverse voltage	Vr		5	V	
Operation Temperature	T _{op}	-30	75	°C	
Storage Temperature	T _{stg}	-40	85	°C	

Note1 : To test conditions is to stand on IEC 61000-4-2 ◦

VESDc : To contact discharge for Input Connector ◦

VESDm : To contact discharge for module ◦

Note2 : condition: 1 pcs LED 、 1/10 duty 、 0.1msec width ◦

3. ELECTRICAL CHARACTERISTICS

3.1. TFT LCD (Power Supply Voltage)

(GND=AVSS=0V)

Parameter	SYMBOL	Min	Typ	Max	Unit	Remarks
Power Supply Voltage for Digital	VCC	3	3.3	3.6	V	
Power Supply Voltage for Analog	AVDD	4.5	5	5.5	V	
Gate On Voltage	VGH	17	18	19	V	
Gate Off Voltage	VGL	-6.6	-6	-5.4	V	
Common Voltage	VCAC	4.8	5.2	6	Vp-p	[Note1]
	VCDC	1.5	1.6	1.7	V	[Note2]
Input Signal Voltage	VIH	0.7VCC	-	VCC	V	
	VIL	0	-	0.3VCC	V	

[Note1] : Brightness level is adjusted by varying this amplitude VCAC

[Note2] : Please adjust VCDC to make the flicker level be minimum.

3.2. TFT-LCD (consumption Current)

(GND=AVSS=0V)

Parameter	SYMBOL	Condition	Min	Typ	Max	Unit	Remarks
Gate on Current	IVGH	VGH =18V	-	0.05	0.1	mA	[Note1]
Gate off Current	IVGL	VGL= -6V	-	0.05	0.1	mA	[Note1]
Digital Current	IVCC	VCC = 3.3V	-	1.5	2	mA	[Note1]
Analog Current	IAVDD	AVDD = 5V	-	4	4.5	mA	[Note1]
Total Power Consumption	PC		-	26.2	31.5	mW	[Note1]

[Note1] : Typ. specification : 256 Gray test Pattern

Max. specification : Black test Pattern



(a)256 Gray Pattern

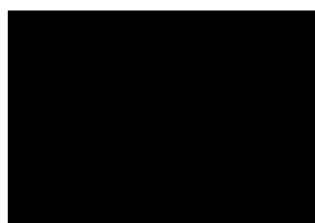

(b)Black Pattern

3.3. Backlight system

ITEM	SYMBOL	MIN	TYP	MAX	UNIT	NOTE
LED Voltage	VL	18	20.4	22.8	V	
LED Current	IL		20		mA	
Power consumption	WL		408		mW	

3.4. Power on/off sequence

Power On : VCC→AVDD/VGL→VGH→Data

Power Off : Data→VGH→AVDD/VGL→VCC

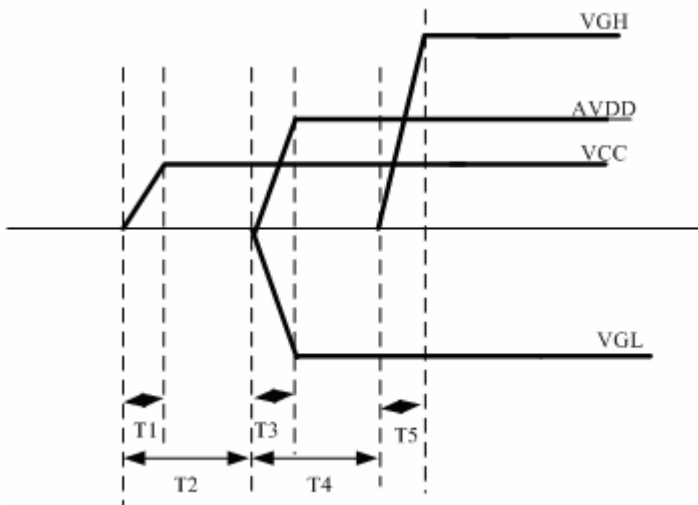

- T1 ≤ 10ms
- T2 ≤ 20ms
- T3 ≤ 10ms
- T4 ≤ 20ms
- T5 ≤ 10ms

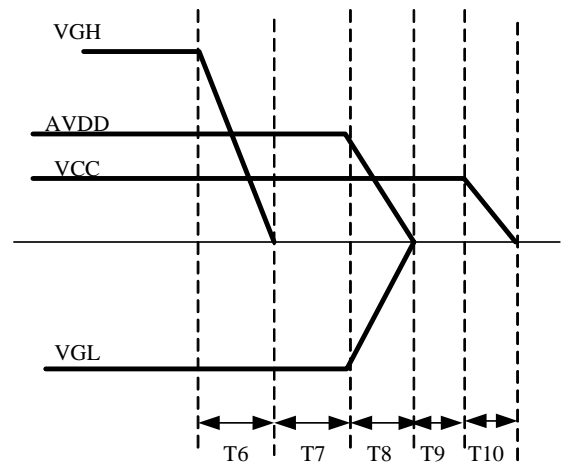

- T6 ≤ 10ms
- T7 ≤ 10ms
- T8 ≤ 10ms
- T9 ≤ 10ms
- T10 ≤ 10ms

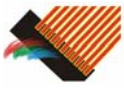

4. INPUT SIGNAL TIMING

4.1. Timing Specification

characteristics		SYMBOL	MIN	TYP	MAX	UNIT	NOTE
DCLK	Period	T _{OSC}	125	160	197	ns	
	Dot Clock	F _{OSC}	5.08	6.25	8	MHz	
DE MODE	Data setup time	T _{SU}	12	-	-	ns	
	Data hold time	T _{HD}	12	-	-	ns	
	Horizontal Period	T _H	370	400	440	T _{OSC}	
	Horizontal Valid	T _{HV}	320				
	Horizontal Blank	T _{HBK}	50	80			120
	Vertical Period	T _{VP}	250	260	280	T _H	
	Vertical Valid	T _{VV}	240				
	Vertical Blank	T _{VBK}	10	20			40
	Vertical Frequency	F _V	55	60	65	Hz	
SYNC MODE	Horizontal Period	T _H	370	400	440	T _{OSC}	
	Horizontal Pulse Width	T _{HS}	5	20	30		
	Horizontal Pulse Width + Back Proch	T _{HPWB}	25	45	75		
	Horizontal Front Proch	T _{HFP}	25	35	45		
	Horizontal Valid	T _{HV}	320				
	Horizontal pulse width	T _{HS}	5	30	-	T _{OSC}	
	Horizontal rising time	T _{Cr}	-	-	700	ns	
	Horizontal falling time	T _{Cf}	-	-	300	ns	
	Vertical Period	T _{VP}	250	260	280	T _H	
	Vertical Pulse Width	T _{VS}	1	3	5		
	Vertical Pulse Width + Back Proch	T _{VPWB}	5	10	15		
	Vertical Front Proch	T _{VFP}	5	10	25		
	Vertical Valid	T _{VV}	240				
	Vertical Frequency	F _V	55	60	65	Hz	
	Vertical pulse width	T _{VS}	1	3	5	T _H	
	Vertical rising time	T _{Vr}	-	-	700	ns	
Vertical falling time	T _{Vf}	-	-	1.5	us		

Note : This module must operate for DE and SYNC mode.

4.2. Timing Chart

(1) CLK, DATA, DEN waveform timing

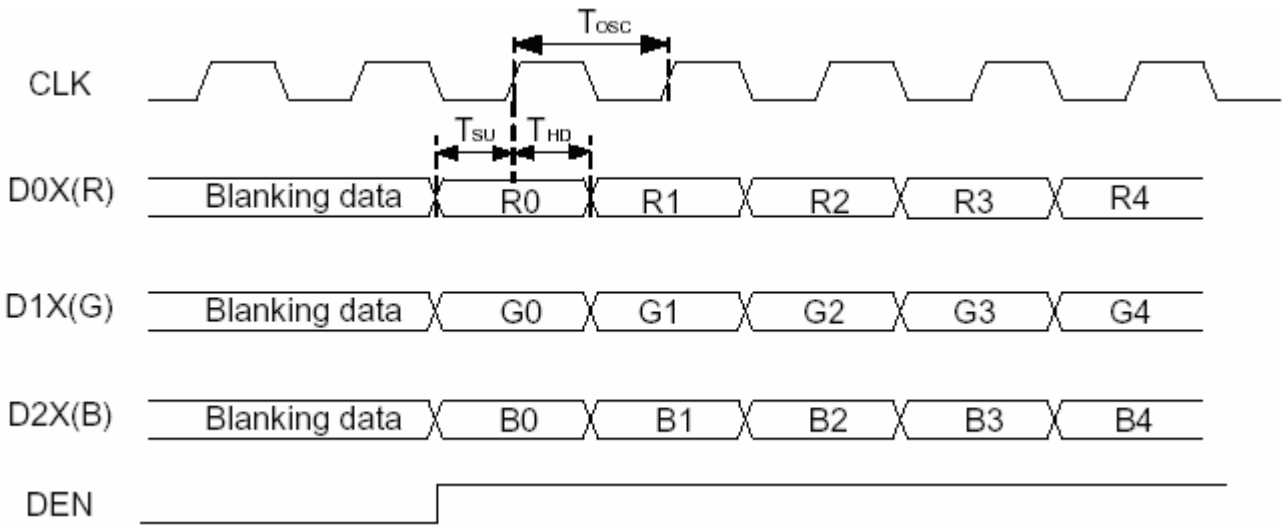

(2) HIS, IVS waveform timing

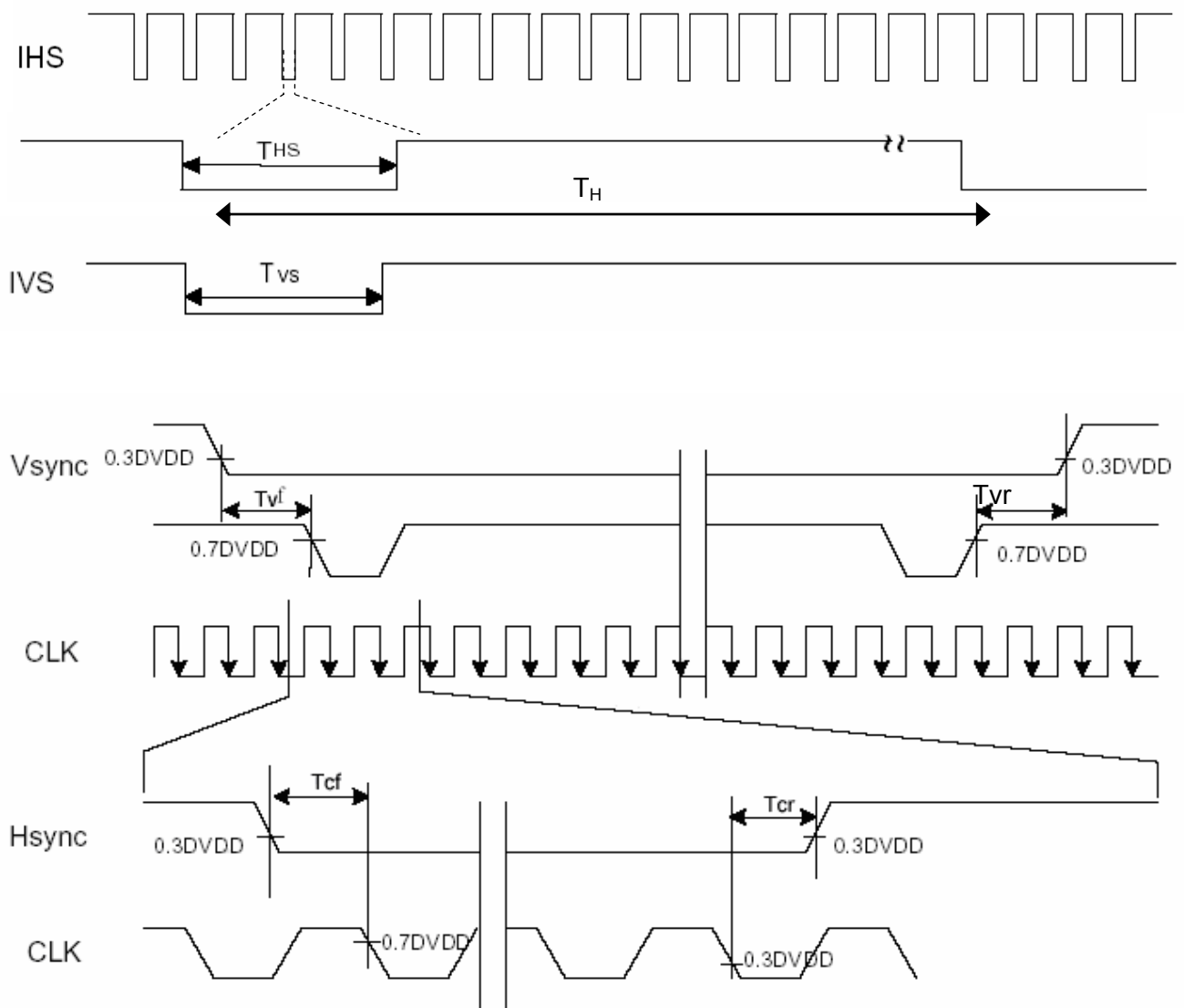

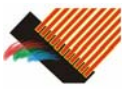

(3) Color data definition

COLOR	INPUT DATA	R DATA								G DATA								B DATA							
		R7	R6	R5	R4	R3	R2	R1	R0	G7	G6	G5	G4	G3	G2	G1	G0	B7	B6	B5	B4	B3	B2	B1	B0
		MSB							LSB	MSB							LSB	MSB							LSB
BASIC COLOR	BLACK	0	0	0	0	0	0	0	0	0	0	0	0	0	0	0	0	0	0	0	0	0	0	0	0
	RED(255)	1	1	1	1	1	1	1	1	0	0	0	0	0	0	0	0	0	0	0	0	0	0	0	0
	GREEN(255)	0	0	0	0	0	0	0	0	1	1	1	1	1	1	1	1	0	0	0	0	0	0	0	0
	BLUE(255)	0	0	0	0	0	0	0	0	0	0	0	0	0	0	0	0	1	1	1	1	1	1	1	1
	CYAN	0	0	0	0	0	0	0	0	1	1	1	1	1	1	1	1	1	1	1	1	1	1	1	1
	MAGENTA	1	1	1	1	1	1	1	1	0	0	0	0	0	0	0	0	1	1	1	1	1	1	1	1
	YELLOW	1	1	1	1	1	1	1	1	1	1	1	1	1	1	1	1	0	0	0	0	0	0	0	0
	WHITE	1	1	1	1	1	1	1	1	1	1	1	1	1	1	1	1	1	1	1	1	1	1	1	1
RED	RED(0)	0	0	0	0	0	0	0	0	0	0	0	0	0	0	0	0	0	0	0	0	0	0	0	0
	RED(1)	0	0	0	0	0	0	0	1	0	0	0	0	0	0	0	0	0	0	0	0	0	0	0	0
	RED(2)	0	0	0	0	0	0	1	0	0	0	0	0	0	0	0	0	0	0	0	0	0	0	0	0
	RED(254)	1	1	1	1	1	1	1	0	0	0	0	0	0	0	0	0	0	0	0	0	0	0	0	0
	RED(255)	1	1	1	1	1	1	1	1	0	0	0	0	0	0	0	0	0	0	0	0	0	0	0	0
GREEN	GREEN(0)	0	0	0	0	0	0	0	0	0	0	0	0	0	0	0	0	0	0	0	0	0	0	0	0
	GREEN(1)	0	0	0	0	0	0	0	0	0	0	0	0	0	0	0	1	0	0	0	0	0	0	0	0
	GREEN(2)	0	0	0	0	0	0	0	0	0	0	0	0	0	0	1	0	0	0	0	0	0	0	0	0
	GREEN(254)	0	0	0	0	0	0	0	0	1	1	1	1	1	1	1	0	0	0	0	0	0	0	0	0
	GREEN(255)	0	0	0	0	0	0	0	0	1	1	1	1	1	1	1	1	0	0	0	0	0	0	0	0
BLUE	BLUE(0)	0	0	0	0	0	0	0	0	0	0	0	0	0	0	0	0	0	0	0	0	0	0	0	0
	BLUE(1)	0	0	0	0	0	0	0	0	0	0	0	0	0	0	0	0	0	0	0	0	0	0	0	1
	BLUE(2)	0	0	0	0	0	0	0	0	0	0	0	0	0	0	0	0	0	0	0	0	0	0	1	0
	BLUE(254)	0	0	0	0	0	0	0	0	0	0	0	0	0	0	0	0	1	1	1	1	1	1	1	0
	BLUE(255)	0	0	0	0	0	0	0	0	0	0	0	0	0	0	0	0	1	1	1	1	1	1	1	1

[Remark] :

*1) Definition of gray scale:

Color (n): n means level of gray scale. Larger n means brighter level.

*2) Data: 1= High, 0 = Low

5.INTERFACE CONNECTION

Pin No.	SYMBOL	I/O	Function	Note
1	LED-	-		
2	LED-	-		
3	LED+	I	Backlight positive voltage.	
4	LED+	I	Backlight positive voltage.	
5	DUMMY	-		
6	DUMMY	-		
7	POL	O	Polarity select for line inversion.	Note1
8	RESET	I	Hardware global reset.	Note2
9	SPENA	I	Serial port data enable.	Note3
10	SPCLK	I	Serial port clock.	
11	SPDAT	I/O	Serial port data.	
12	B0	I	Digital blue data input.	
13	B1	I	Digital blue data input.	
14	B2	I	Digital blue data input.	
15	B3	I	Digital blue data input.	
16	B4	I	Digital blue data input.	
17	B5	I	Digital blue data input.	
18	B6	I	Digital blue data input.	
19	B7	I	Digital blue data input.	
20	G0	I	Digital green data input.	
21	G1	I	Digital green data input.	
22	G2	I	Digital green data input.	
23	G3	I	Digital green data input.	
24	G4	I	Digital green data input.	
25	G5	I	Digital green data input.	
26	G6	I	Digital green data input.	
27	G7	I	Digital green data input.	
28	R0	I	Digital red data input.	
29	R1	I	Digital red data input.	
30	R2	I	Digital red data input.	
31	R3	I	Digital red data input.	
32	R4	I	Digital red data input.	
33	R5	I	Digital red data input.	
34	R6	I	Digital red data input.	
35	R7	I	Digital red data input.	
36	HSYNC	I	Horizontal sync input.	
37	VSYNC	I	Vertical sync input.	
38	DCLK	I	Clock input.	
39	VDD	I	Analog power.	
40	VDD	I	Analog power.	
41	VCC	I	Digital power.	
42	VCC	I	Digital power.	
43	DUMMY	-		
44	DUMMY	-		
45	VGL	I	Gate driver negative voltage	
46	DUMMY	-		
47	VGH	I	Gate driver positive voltage	

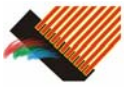

48	DUMMY	-		
49	DUMMY	-		
50	DUMMY	-		
51	VCOM	I	Voltage applied to color filter substrate.	Note4
52	ENB	I	Data enable control.	
53	GND	-		
54	VSS	-		

Note1 : The function of POL is polarity select for line inversion control signal.

POL	H	L
Output voltage polarity	positive	negative

Note2 : RESETB pin normally pull high.
Hardware global reset. Low active.

Note3 : SPCLK for serial port clock. Normally pull high.
SPDAT for serial port Data input/output.
SPENA for serial port Data Enable signal. Normally pull high.

Note4 : Suggestion VCOM circuit

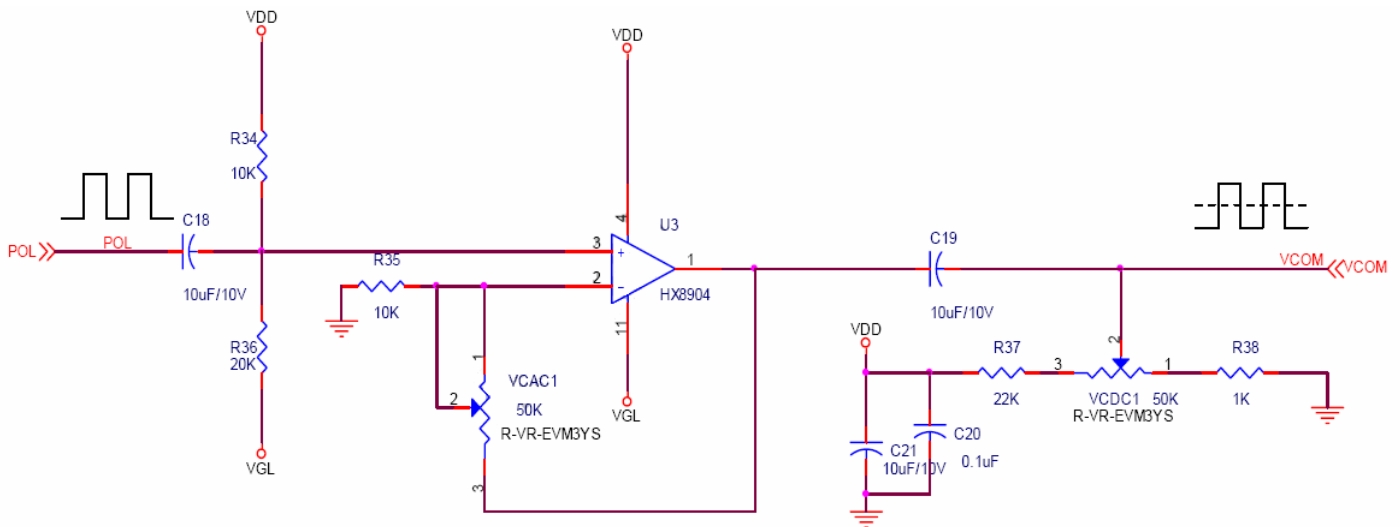

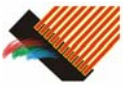

JINWANG

6. MECHANICAL DIMENSION

6.1. Front Side

Unit : mm

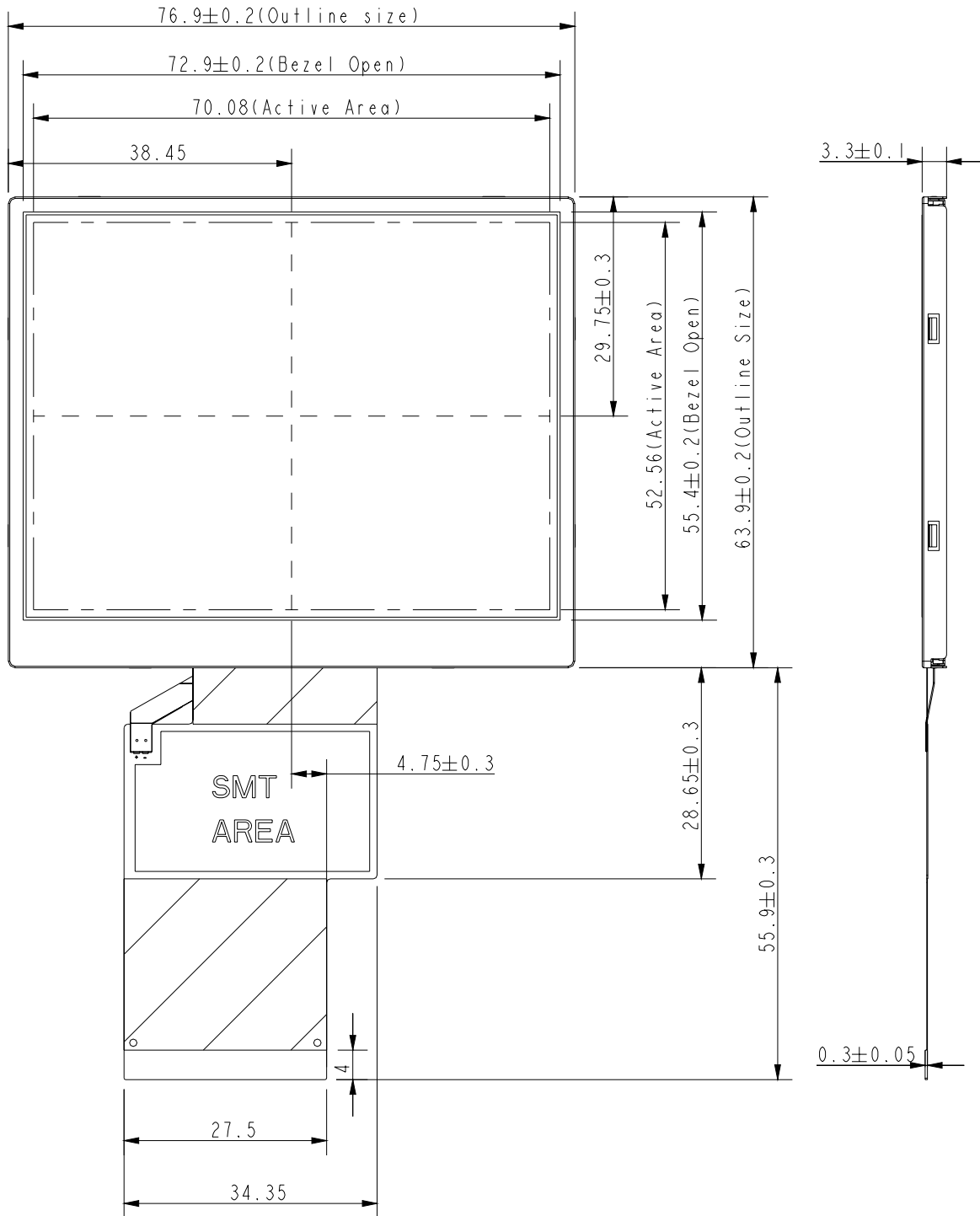

6.2.Rear Side

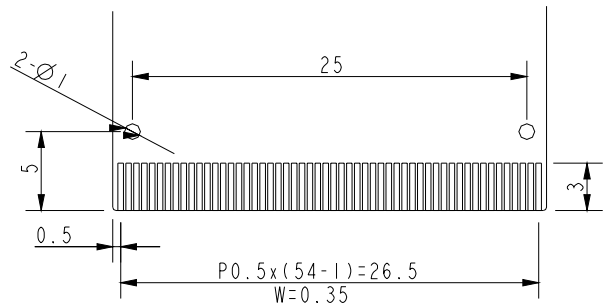
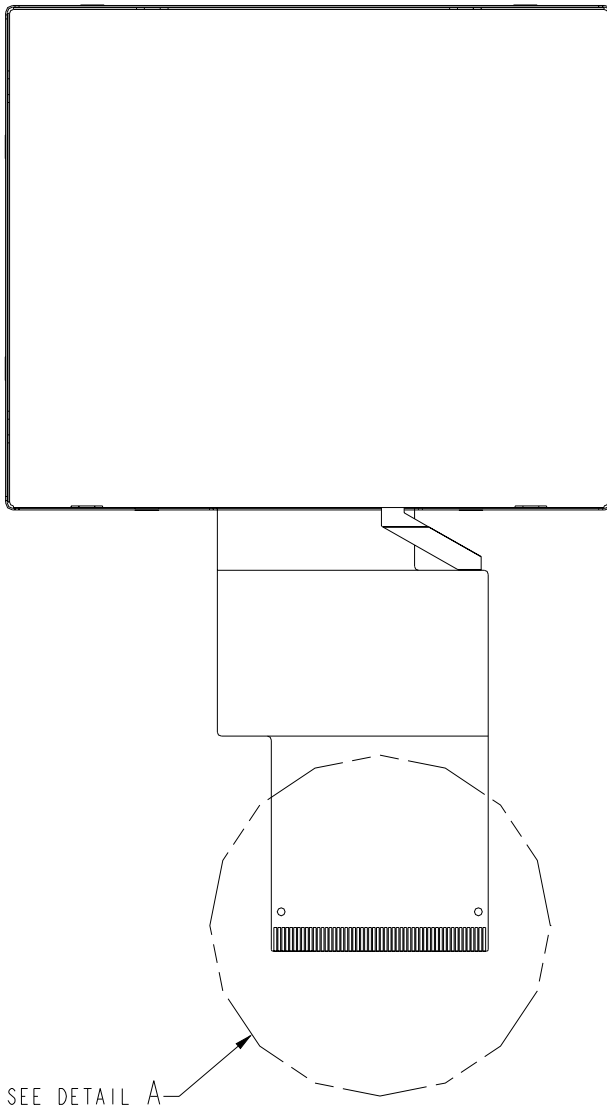

DETAIL A
SCALE 2:1

7. OPTICAL CHARACTERISTICS

Ta=25°C

ITEM	SYMBOL	CONDITION	MIN.	TYP.	MAX.	UNIT	Remarks
Contrast Ratio (center)	CR	Point-5	240	300	--	--	*1)
Luminance	center Luminance	L	200	250	--	cd/m ²	*2)
	Uniformity	ΔL	80	--	--	%	*2)
Response Time	tr+tf		--	25	--	ms	*3)
Viewing Angle	Horizontal	CR ≥ 10 Point-5	110	120	--	°	*4)
	Vertical		90	100	--	°	*4)
Color Coordinate	Red	Rx Ry	0.561 0.286	0.601 0.326	0.641 0.366	--	*2)*3)
	Green	Gx Gy	0.289 0.531	0.329 0.571	0.369 0.611		
	Blue	Bx By	0.107 0.060	0.147 0.100	0.187 0.140		
	White	Wx Wy	0.267 0.280	0.307 0.320	0.347 0.360		
	Gamut		--	54.6%	--		

[Note] : These items are measured by BM-5A (TOPCON) in the dark room. IL= 20.0mA ; View Cone : 1°

*1 Definition of contrast ratio :

1) Contrast Ratio (CR) = (White) Luminance of ON ÷ (Black) Luminance of OFF

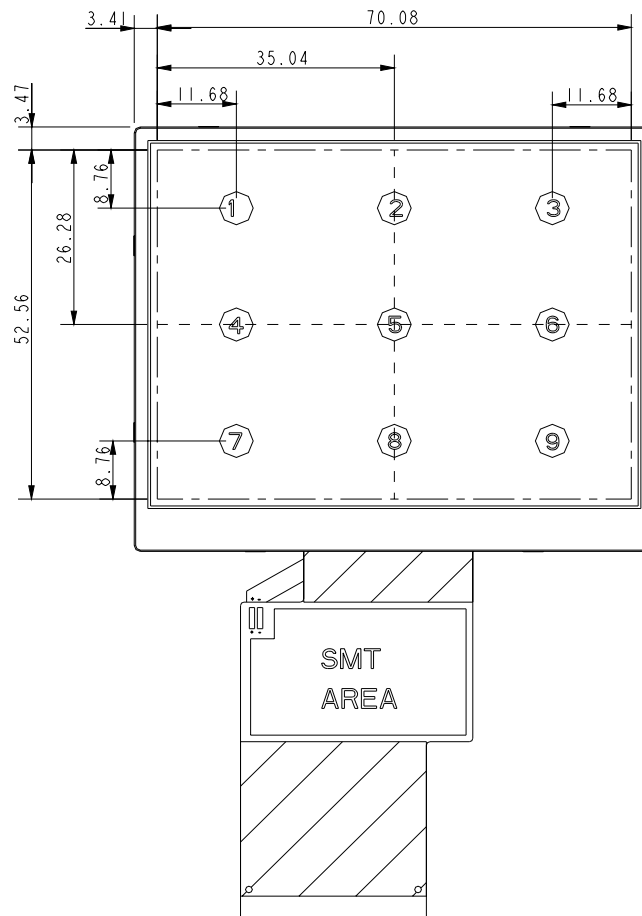

Fig.1 Measuring point

***2 Definition of Center Luminance & Luminance Uniformity :**

- 1) Center Luminance (L) = Measure the luminance on the center point as figure 7-1 #5 point
 - 2) Measure maximum luminance and minimum luminance on the 9 points as figure 7-1 (#1~#9 point). Luminance Uniformity is calculated with the following formula :
- $$L = [L \Delta (\text{MIN}) / L (\text{MAX})] \times 100\%$$

***3 Definition of Response Time. (White - Black)**

The response time is defined as the time interval between the 10% and 90% amplitudes.

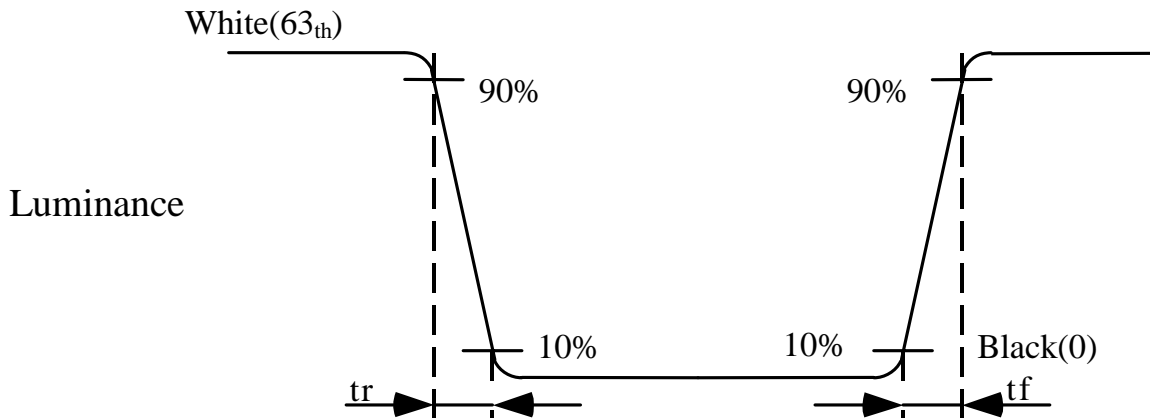

Fig.2 Definition of Response Time (White - Black)

***4 Definition of Viewing Angle(θ, ψ) : (by EZ-CONTRAST (ELDIM) in the dark room.)**

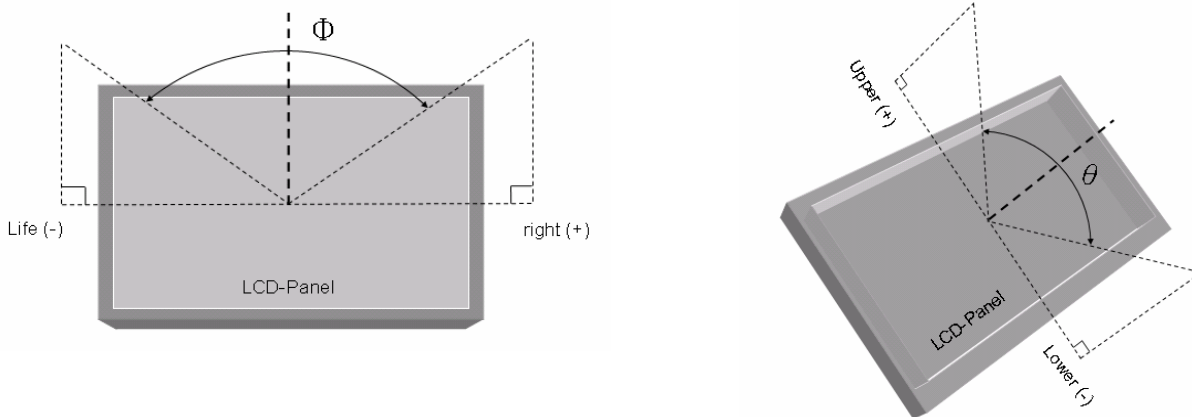
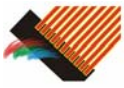

Fig.3 Definition of Viewing Angle



8. RELIABILITY TEST CONDITIONS

(1) Temperature and Humidity

TEST ITEMS	CONDITIONS
HIGH TEMPERATURE OPERATION	75° C ; 240Hrs
HIGH TEMPERATURE STORAGE	85° C ; 240Hrs
HIGH TEMPERATURE AND HIGH HUMIDITY OPERATION	60° C ; 90%RH ; 240Hrs
LOW TEMPERATURE OPERATION	-30° C ; 240Hrs
LOW TEMPERATURE STORAGE	-40° C ; 240Hrs
THERMAL SHOCK (No operation)	-30° C (0.5Hr)~85° C (0.5Hr) 200 CYCLE

(2) Shock & Vibration

TEST ITEMS	CONDITIONS
SHOCK (NON-OPERATION)	<ul style="list-style-type: none"> ● Shock level: 980m/s²(equal to 100G). ● Waveform: half sinusoidal wave,6ms. ● Number of shocks: one shock input in each direction of three mutually perpendicular axes for a total of three shock inputs.
VIBRATION (NON-OPERATION)	<ul style="list-style-type: none"> ● Frequency range:8~33.3Hz ● Stoke : 1.3 mm ● Vibration: sinusoidal wave, perpendicular axis(both x,z axis: 2Hrs , and y axis: 4Hrs). ● Sweep: 2.9G,33.3 Hz -400 Hz ● Cycle: 15 min

(3) ESD

TEST ITEM	CONDITIONS	Note
ESD	150pF , 330Ω , ±8Kv & ±15kV air & contact test	(1)
	200pF , 0Ω , ±200V contact test	(2)

[NOTE] : Measure point :(1)LCD glass and metal bezel (2)IF connector pins

(4) Judgment standard

The judgment of the above test should be made as follow:

Pass : Normal display image with no obvious non-uniformity and no line defect. Partial transformation of the module parts should be ignored.

Fail : No display image, obvious non-uniformity, or line defects.

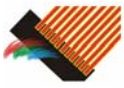

9. HANDLING PRECAUTIONS FOR TFT-LCD MODULE

Please pay attention to the followings in handling- TFT-LCD products :

(A) ASSEMBLY PRECAUTION

- (1) Please use the mounting hole on the module side in installing and do not beading or wrenching LCD in assembling. And please do not drop, bend or twist LCD module in handling.
- (2) Please design display housing in accordance with the following guide lines.
 - (2.1) Housing case must be destined carefully so as not to put stresses on LCD all sides and not to wrench module. The stresses may cause non-uniformity even if there is no non-uniformity statically.
 - (2.2) Keep sufficient clearance between LCD module back surface and housing when the LCD module is mounted. Approximately 1.0 mm of the clearance in the design is recommended taking into account the tolerance of LCD module thickness and mounting structure height on the housing.
 - (2.3) When some parts, such as, FPC cable and ferrite plate, are installed underneath the LCD module, still sufficient clearance is required, such as 0.5mm. This clearance is, especially, to be reconsidered when the additional parts are implemented for EMI countermeasure.
 - (2.4) Design the inverter location and connector position carefully so as not to give stress to lamp cable, or not to interface the LCD module by the lamp cable.
 - (2.5) Keep sufficient clearance between LCD module and the others parts, such as inverter and speaker so as not to interface the LCD module. Approximately 1.0mm of the clearance in the design is recommended.
- (3) Please do not push or scratch LCD panel surface with any-thing hard. And do not soil LCD panel surface by touching with bare hands. (Polarizer film, surface of LCD panel is easy to be flawed.)
- (4) Please do not press any parts on the rear side such as source TCP, gate TCP, control circuit board and FPCs during handling LCD module. If pressing rear part is unavoidable, handle the LCD module with care not to damage them.
- (5) Please wipe out LCD panel surface with absorbent cotton or soft cloth in case of it being soiled.
- (6) Please wipe out drops of adhesives like saliva and water on LCD panel surface immediately. They might damage to cause panel surface variation and color change.
- (7) Please do not take a LCD module to pieces and reconstruct it. Resolving and reconstructing modules may cause them not to work well.
- (8) Please do not touch metal frames with bare hands and soiled gloves. A color change of the metal frames can happen during a long preservation of soiled LCD modules.
- (9) Please pay attention to handling lead wire of backlight so that it is not tugged in connecting wit inverter.

(B) OPERATING PRECAUTIONS

- (1) Please be sure to turn off the power supply before connecting and disconnecting signal input cable.
- (2) Please do not change variable resistance settings in LCD module. They are adjusted to the most suitable value. If they are changed, it might happen LCD does not satisfy the characteristics specification.
- (3) Please consider that LCD backlight takes longer time to become stable of radiation characteristics in low temperature than in room temperature.
- (4) A condensation might happen on the surface and inside of LCD module in case of sudden change of ambient temperature.
- (5) Please pay attention to displaying the same pattern for very long time. Image might stick on LCD. If then, time going on can make LCD work well.

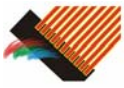

- (6) Please obey the same caution descriptions as ones that need to pay attention to ordinary electronic parts.

(C) PRECAUTIONS WITH ELECTROSTATICS

- (1) This LCD module uses CMOS-IC on circuit board and TFT-LCD panel, and so it is easy to be affected by electrostatics. Please be careful with electrostatics by the way of your body connecting to the ground and so on.
- (2) Please remove protection film very slowly on the surface of LCD module to prevent from electrostatics occurrence.

(D) STORAGE PRECAUTIONS

- (1) When you store LCDs for a long time, it is recommended to keep the temperature between 0°C-40°C without the exposure of sunlight and to keep the humidity less than 90%RH.
- (2) Please do not leave the LCDs in the environment of high humidity and high temperature such as 60°C 90%RH.
- (3) Please do not leave the LCDs in the environment of low temperature; below -20°C.

(E) SAFETY PRECAUTIONS

- (1) When you waste LCDs, it is recommended to crush damaged or unnecessary LCDs into pieces and wash them off with solvents such as acetone and ethanol, which should later be burned.
- (2) If any liquid leaks out of a damaged-glass cell and comes in contact with the hands, wash off thoroughly with soap and water.

(F) OTHERS

- (1) A strong incident light into LCD panel might cause display characteristics' changing inferior because of polarizer film, color filter, and other materials becoming inferior. Please do not expose LCD module direct sunlight and strong UV rays.
- (2) Please pay attention to a panel side of LCD module not to contact with other materials in preserving it alone.
- (3) For the packaging box, please pay attention to the followings:
 - (3.1) Packaging box and inner case for LCD are designed to protect the LCDs from the damage or scratching during transportation. Please do not open except picking LCDs up from the box.
 - (3.2) Please do not pile them up more than 5 boxes. (They are not designed so.) And please do not turn over.
 - (3.3) Please handle packaging box with care not to give them sudden shock and vibrations. And also please do not throw them up.
 - (3.4) Packing box and inner case for LCDs are made of cardboard. So please pay attention not to get them wet. (Such like keeping them in high humidity or wet place can occur getting them wet.)

Looking for pricing, stock, or lifecycle information?

Click below to explore more details on WIN SOURCE:

-  [View 913 on WIN SOURCE](#)
-  [Adafruit Industries LLC Information](#)

Optimize Your Supply Chain with WIN SOURCE Solutions

-  Global Sourcing Solution
-  Obsolete Management
-  Cost Control Management
-  Shortage Management
-  Alternative Solution
-  Excess Inventory Management