



**THE DATASHEET OF
AC0805JR-0712KL**



UCC20520 4-A, 6-A, 5.7-kV_{RMS} Isolated Dual-Channel Gate Driver with Single Input

1 Features

- Single input, dual output
- Operating temperature range: –40 to 125°C
- Switching parameters:
 - 19-ns typical propagation delay
 - 10-ns minimum pulse width
 - 5-ns maximum delay matching
 - 6-ns maximum pulse-width distortion
- Common-mode transient immunity (CMTI) greater than 100-V/ns
- Surge immunity up to 12.8-kV
- Isolation barrier life >40 Years
- 4-A peak source, 6-A peak sink output
- TTL and CMOS compatible inputs
- 3-V to 18-V input VCCI range to interface with both digital and analog controllers
- Up to 25-V VDD output drive supply
- Programmable dead time
- Rejects input pulses and noise transients shorter than 5-ns
- Fast disable for power sequencing
- Industry standard wide body SOIC-16 (DW) package
- Safety-related and regulatory approvals:
 - 8000-V_{PK} isolation per DIN V VDE V 0884-11:2017-01
 - 5700-V_{RMS} isolation for 1 minute per UL 1577
 - CSA certification per IEC 60950-1, IEC 62368-1, IEC 61010-1 and IEC 60601-1 end equipment standards
 - CQC certification per GB4943.1-2011

2 Applications

- Isolated converters in offline AC-to-DC power supplies
- Server, telecom, IT and industrial infrastructures
- Motor drive and DC-to-AC solar inverters
- LED lighting
- Inductive heating
- Uninterruptible power supply (UPS)
- HEV and BEV battery chargers

3 Description

The UCC20520 is an isolated single input, dual-channel gate driver with 4-A source and 6-A sink peak current. It is designed to drive power MOSFETs, IGBTs, and SiC MOSFETs up to 5-MHz with best-in-class propagation delay and pulse-width distortion.

The input side is isolated from the two output drivers by a 5.7-kV_{RMS} reinforced isolation barrier, with a minimum of 100-V/ns common-mode transient immunity (CMTI). Internal functional isolation between the two secondary-side drivers allows a working voltage of up to 1500-V_{DC}.

This driver can be used for half-bridge driver with programmable dead time (DT). A disable pin shuts down both outputs simultaneously when it is set high, and allows normal operation when left open or grounded. As a fail-safe measure, primary-side logic failures force both outputs low.

The device accepts VDD supply voltages up to 25-V. A wide input VCCI range from 3-V to 18-V makes the driver suitable for interfacing with both analog and digital controllers. All the supply voltage pins have under voltage lock-out (UVLO) protection.

With all these advanced features, the UCC20520 enables high efficiency, high power density, and robustness in a wide variety of power applications.

Device Information

PART NUMBER	PACKAGE ⁽¹⁾	BODY SIZE (NOM)
UCC20520	DW SOIC (16)	10.30 mm × 7.50 mm

(1) For all available packages, see the orderable addendum at the end of the data sheet.

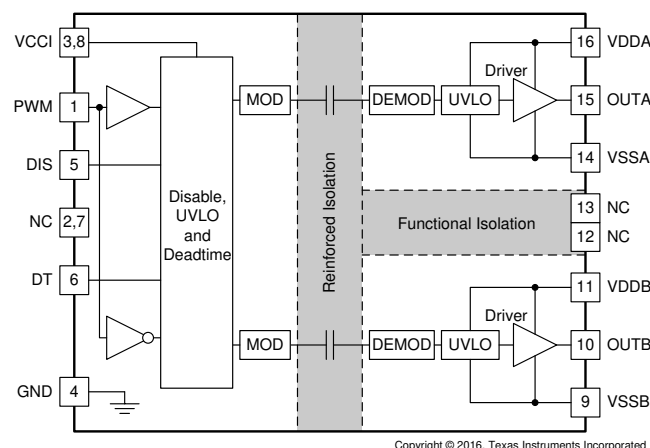

Functional Block Diagram

Table of Contents

1 Features	1	7.3 PWM Input and Disable Response Time.....	15
2 Applications	1	7.4 Programmable Dead Time.....	16
3 Description	1	7.5 CMTI Testing.....	16
4 Revision History	2	8 Detailed Description	17
5 Pin Configuration and Functions	3	8.1 Overview.....	17
6 Specifications	4	8.2 Functional Block Diagram.....	17
6.1 Absolute Maximum Ratings.....	4	8.3 Feature Description.....	18
6.2 ESD Ratings.....	4	8.4 Device Functional Modes.....	21
6.3 Recommended Operating Conditions.....	4	9 Application and Implementation	23
6.4 Thermal Information.....	5	9.1 Application Information.....	23
6.5 Power Ratings.....	5	9.2 Typical Application.....	23
6.6 Insulation Specifications.....	6	10 Layout	35
6.7 Safety-Related Certifications.....	7	10.1 Layout Guidelines.....	35
6.8 Safety-Limiting Values.....	7	10.2 Layout Example.....	36
6.9 Electrical Characteristics.....	8	11 Device and Documentation Support	38
6.10 Switching Characteristics.....	9	11.1 Documentation Support.....	38
6.11 Insulation Characteristics Curves.....	10	11.2 Receiving Notification of Documentation Updates..	38
6.12 Typical Characteristics.....	11	11.3 Support Resources.....	38
7 Parameter Measurement Information	15	11.4 Trademarks.....	38
7.1 Propagation Delay and Pulse Width Distortion.....	15	11.5 Electrostatic Discharge Caution.....	38
7.2 Rising and Falling Time.....	15	11.6 Glossary.....	38

4 Revision History

Changes from Revision * (November 2016) to Revision A (January 2022)	Page
• Updated the numbering format for tables, figures, and cross-references throughout the document.....	1
• Changed maximum pulse-width distortion value in <i>Features</i> from "5 ns" to "6 ns".....	1
• Changed maximum pulse width distortion specification in <i>Section 6.10</i> from "5 ns" to "6 ns".....	9
• Updated bench test waveform colors for better readability only. No data or measurement changes.	33

5 Pin Configuration and Functions

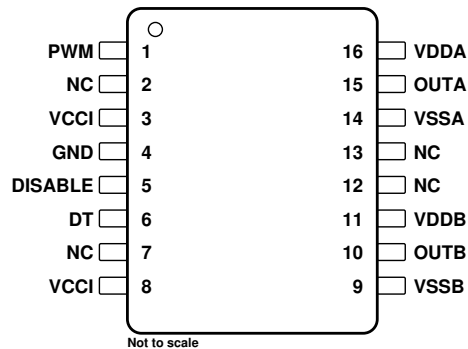

Figure 5-1. DW Package, 16-Pin SOIC (Top View)

Table 5-1. Pin Functions

PIN		TYPE ¹	DESCRIPTION
NAME	NO.		
DISABLE	5	I	Disables both driver outputs if asserted high, enables if set low or left open. This pin is pulled low internally if left open. It is recommended to tie this pin to ground if not used to achieve better noise immunity.
DT	6	I	Programmable dead time function. Tying DT to VCCI disables the DT function with dead time ≈ 0 ns. Leaving DT open sets the dead time to <15 ns. Placing a 500- Ω to 500-k Ω resistor (R_{DT}) between DT and GND adjusts dead time according to: DT (in ns) = $10 \times R_{DT}$ (in k Ω). It is recommended to parallel a ceramic capacitor, ≥ 2.2 -nF, with R_{DT} to achieve better noise immunity.
GND	4	P	Primary-side ground reference. All signals in the primary side are referenced to this ground.
NC	2	–	No connection.
NC	7	–	No connection.
NC	12	–	No connection.
NC	13	–	No connection.
OUTA	15	O	Output of driver A. Connect to the gate of the A channel FET or IGBT. Output A is in phase with PWM input with a propagation delay
OUTB	10	O	Output of driver B. Connect to the gate of the B channel FET or IGBT. Output B is always complementary to output A with a programmed dead time.
PWM	1	I	PWM input has a TTL/CMOS compatible input threshold. This pin is pulled low internally if left open.
VCCI	3	P	Primary-side supply voltage. Locally decoupled to GND using a low ESR/ESL capacitor located as close to the device as possible.
VCCI	8	P	Primary-side supply voltage. This pin is internally shorted to pin 3.
VDDA	16	P	Secondary-side power for driver A. Locally decoupled to VSSA using a low ESR/ESL capacitor located as close to the device as possible.
VDDB	11	P	Secondary-side power for driver B. Locally decoupled to VSSB using a low ESR/ESL capacitor located as close to the device as possible.
VSSA	14	P	Ground for secondary-side driver A. Ground reference for secondary side A channel.
VSSB	9	P	Ground for secondary-side driver B. Ground reference for secondary side B channel.

1. I = input, O = output, I/O = input or output, FB = feedback, G = ground, P = power

6 Specifications

6.1 Absolute Maximum Ratings

over operating free-air temperature range (unless otherwise noted)⁽¹⁾

	MIN	MAX	UNIT
VCCI to GND	-0.3	20	V
VDDA-VSSA, VDDDB-VSSB	-0.3	30	V
OUTA to VSSA, OUTB to VSSB	-0.3	$V_{VDDA}+0.3$, $V_{VDDDB}+0.3$	V
OUTA to VSSA, OUTB to VSSB, Transient for 200 ns	-2	$V_{VDDA}+0.3$, $V_{VDDDB}+0.3$	V
PWM, DIS, DT to GND	-0.3	$V_{VCCI}+0.3$	V
PWM Transient for 50 ns	-5	$V_{VCCI}+0.3$	V
VSSA-VSSB, VSSB-VSSA		1500	V
Junction temperature, T_J ⁽²⁾	-40	150	°C
Storage temperature, T_{stg}	-65	150	°C

- (1) Stresses beyond those listed under *Absolute Maximum Ratings* may cause permanent damage to the device. These are stress ratings only, which do not imply functional operation of the device at these or any other conditions beyond those indicated under *Recommended Operating Conditions*. Exposure to absolute-maximum-rated conditions for extended periods may affect device reliability.
- (2) To maintain the recommended operating conditions for T_J , see the [Section 6.4](#).

6.2 ESD Ratings

		VALUE	UNIT
$V_{(ESD)}$ Electrostatic discharge	Human-body model (HBM), per ANSI/ESDA/JEDEC JS-001 ⁽¹⁾	±4000	V
	Charged-device model (CDM), per JEDEC specification JESD22-C101 ⁽²⁾	±1500	

- (1) JEDEC document JEP155 states that 500-V HBM allows safe manufacturing with a standard ESD control process.
- (2) JEDEC document JEP157 states that 250-V CDM allows safe manufacturing with a standard ESD control process.

6.3 Recommended Operating Conditions

Over operating free-air temperature range (unless otherwise noted)

		MIN	MAX	UNIT
VCCI	VCCI Input supply voltage	3	18	V
VDDA, VDDDB	Driver output bias supply	9.2	25	V
T_A	Ambient Temperature	-40	125	°C
T_J	Junction Temperature	-40	130	°C

6.4 Thermal Information

THERMAL METRIC ⁽¹⁾		UCC20520	UNIT
		DW-16 (SOIC)	
R _{θJA}	Junction-to-ambient thermal resistance	78.1	°C/W
R _{θJC(top)}	Junction-to-case (top) thermal resistance	11.1	°C/W
R _{θJB}	Junction-to-board thermal resistance	48.4	°C/W
Ψ _{JT}	Junction-to-top characterization parameter	12.5	°C/W
Ψ _{JB}	Junction-to-board characterization parameter	48.4	°C/W

(1) For more information about traditional and new thermal metrics, see the *Semiconductor and IC Package Thermal Metrics* application report, [SPRA953](#).

6.5 Power Ratings

		VALUE	UNIT
P _D	Power dissipation by UCC20520DW	1.05	W
P _{DI}	Power dissipation by primary side of UCC20520DW	0.05	W
P _{DA} , P _{DB}	Power dissipation by secondary driver side of UCC20520DW		
		0.5	W

VCCI = 18 V, VDDA/B = 12 V, PWM = 3.3 V, 3 MHz 50% duty cycle square wave 1-nF load

6.6 Insulation Specifications

PARAMETER		TEST CONDITIONS	VALUE	UNIT
CLR	External clearance ⁽¹⁾	Shortest terminal to terminal distance through air	> 8	mm
CPG	External creepage ⁽¹⁾	Shortest terminal to terminal distance across the package surface	> 8	mm
DTI	Distance through insulation	Distance through internal isolation (internal clearance)	>21	μm
CTI	Comparative tracking index	DIN EN 60112 (VDE 0303-11); IEC 60112	> 600	V
	Material group	According to IEC 60664-1	I	
	Overvoltage category per IEC 60664-1	Rated mains voltage ≤ 600 V _{RMS}	I-IV	
		Rated mains voltage ≤ 1000 V _{RMS}	I-III	
DIN V VDE 0884-10 (VDE V 0884-10): 2006-2012⁽²⁾				
V _{IORM}	Maximum repetitive peak isolation voltage	AC voltage (bipolar)	2121	V _{PK}
V _{IOWM}	Maximum isolation working voltage	Time dependent dielectric breakdown (TDDB) test, (See Figure 6-1)	1500	V _{RMS}
			2121	V _{DC}
V _{IOTM}	Maximum transient isolation voltage	V _{TEST} = V _{IOTM} t = 60 sec (qualification) t = 1 sec (100% production)	8000	V _{PK}
V _{IOSM}	Maximum surge isolation voltage ⁽³⁾	Test method per IEC 60065, 1.2/50 μs waveform, V _{TEST} = 1.6 × V _{IOSM} = 12800 V _{PK} (qualification)	8000	V _{PK}
q _{pd}	Apparent charge ⁽⁴⁾	Method a, After Input/Output safety test subgroup 2/3. V _{ini} = V _{IOTM} , t _{ini} = 60s; V _{pd(m)} = 1.2 X V _{IORM} = 2545 V _{PK} , t _m = 10s	<5	pC
		Method a, After environmental tests subgroup 1. V _{ini} = V _{IOTM} , t _{ini} = 60s; V _{pd(m)} = 1.6 X V _{IORM} = 3394 V _{PK} , t _m = 10s	<5	
		Method b1; At routine test (100% production) and preconditioning (type test) V _{ini} = V _{IOTM} ; t _{ini} = 1s; V _{pd(m)} = 1.875 * V _{IORM} = 3977 V _{PK} , t _m = 1s	<5	
C _{IO}	Barrier capacitance, input to output ⁽⁵⁾	V _{IO} = 0.4 sin (2πft), f = 1 MHz	1.2	pF
R _{IO}	Isolation resistance, input to output	V _{IO} = 500 V at T _A = 25°C	> 10 ¹²	Ω
		V _{IO} = 500 V at 100°C ≤ T _A ≤ 125°C	> 10 ¹¹	
		V _{IO} = 500 V at T _S = 150°C	> 10 ⁹	
	Pollution degree		2	
	Climatic category		40/125/21	
UL 1577				
V _{ISO}	Withstand isolation voltage	V _{TEST} = V _{ISO} = 5700 V _{RMS} , t = 60 sec. (qualification), V _{TEST} = 1.2 × V _{ISO} = 6840V _{RMS} , t = 1 sec (100% production)	5700	V _{RMS}

- (1) Creepage and clearance requirements should be applied according to the specific equipment isolation standards of an application. Care should be taken to maintain the creepage and clearance distance of a board design to ensure that the mounting pads of the isolator on the printed-circuit board do not reduce this distance. Creepage and clearance on a printed-circuit board become equal in certain cases. Techniques such as inserting grooves and/or ribs on a printed circuit board are used to help increase these specifications.
- (2) This coupler is suitable for basic electrical insulation only within the maximum operating ratings. Compliance with the safety ratings shall be ensured by means of suitable protective circuits.
- (3) Testing is carried out in air or oil to determine the intrinsic surge immunity of the isolation barrier.
- (4) Apparent charge is electrical discharge caused by a partial discharge (pd).
- (5) All pins on each side of the barrier tied together creating a two-terminal device.

6.7 Safety-Related Certifications

VDE	CSA	UL	CQC
Certified according to DIN VDE V 0884-10 (VDE V 0884-10):2006-12 and DIN EN 60950-1 (VDE 0805 Teil 1):2011-01	Approved under CSA Component Acceptance Notice 5A, IEC 60950-1 and IEC 60601-1	Certified according to UL 1577 component recognition program	Certified according to GB 4943.1-2011
Reinforced insulation maximum transient isolation voltage, 8000 V _{PK} ; maximum repetitive peak isolation voltage, 2121 V _{PK} ; maximum surge isolation voltage, 8000 V _{PK}	Reinforced insulation per CSA 60950-1-07+A1+A2 and IEC 60950-1 2nd Ed.	Single protection, 5700 V _{RMS}	Reinforced insulation, Altitude ≤ 5000 m, Tropical climate, 400 V _{RMS} maximum working voltage
Certification number: 40040142	Agency qualification planned	File number: E181974	Certification number: CQC16001155011

6.8 Safety-Limiting Values

Safety limiting intends to prevent potential damage to the isolation barrier upon failure of input or output circuitry. A failure of the I/O can allow low resistance to ground or the supply and, without current limiting, dissipate sufficient power to overheat the die and damage the isolation barrier potentially leading to secondary system failures.

PARAMETER	TEST CONDITIONS	SIDE	MIN	TYP	MAX	UNIT
I _S Safety output supply current	R _{θJA} = 78.1°C/W, VDDA/B = 12 V, T _A = 25°C, T _J = 150°C See Figure 6-2	DRIVER A, DRIVER B			64	mA
	R _{θJA} = 78.1°C/W, VDDA/B = 25 V, T _A = 25°C, T _J = 150°C	DRIVER A, DRIVER B			31	mA
P _S Safety supply power	R _{θJA} = 78.1°C/W, T _A = 25°C, T _J = 150°C See Figure 6-3	INPUT			50	mW
		DRIVER A			775	
		DRIVER B			775	
		TOTAL			1600	
T _S Safety temperature					150	°C

The maximum safety temperature is the maximum junction temperature specified for the device. The power dissipation and junction-to-air thermal impedance of the device installed in the application hardware determines the junction temperature. The assumed junction-to-air thermal resistance in the [Section 6.4](#) table is that of a device installed on a High-K test board for leaded surface mount packages. The power is the recommended maximum input voltage times the current. The junction temperature is then the ambient temperature plus the power times the junction-to-air thermal resistance.

6.9 Electrical Characteristics

$V_{VCCI} = 3.3\text{ V}$ or $V_{VCCI} = 5\text{ V}$, $0.1\text{-}\mu\text{F}$ capacitor from VCCI to GND, $V_{VDDA} = V_{VDDB} = 12\text{ V}$, $1\text{-}\mu\text{F}$ capacitor from VDDA and VDDB to VSSA and VSSB, $T_A = -40^\circ\text{C}$ to $+125^\circ\text{C}$, (unless otherwise noted)

PARAMETER		TEST CONDITIONS	MIN	TYP	MAX	UNIT
SUPPLY CURRENTS						
I_{VCCI}	VCCI quiescent current	DISABLE = VCCI		1.5	2.0	mA
I_{VDDA}, I_{VDDB}	VDDA and VDDB quiescent current	DISABLE = VCCI		1.0	1.8	mA
I_{VCCI}	VCCI operating current	(f = 500 kHz) current per channel, $C_{OUT} = 100\text{ pF}$		2.5		mA
I_{VDDA}, I_{VDDB}	VDDA and VDDB operating current	(f = 500 kHz) current per channel, $C_{OUT} = 100\text{ pF}$		2.5		mA
VCCI SUPPLY UNDERVOLTAGE LOCKOUT THRESHOLDS						
V_{VCCI_ON}	Rising threshold VCCI_ON		2.55	2.7	2.85	V
V_{VCCI_OFF}	Falling threshold VCCI_OFF		2.35	2.5	2.65	V
V_{VCCI_HYS}	Threshold hysteresis			0.2		V
VDDA/VDDB SUPPLY UNDERVOLTAGE LOCKOUT THRESHOLDS						
V_{VDDA_ON}, V_{VDDB_ON}	Rising threshold VDDA_ON, VDDB_ON		8	8.5	9	V
$V_{VDDA_OFF}, V_{VDDB_OFF}$	Falling threshold VDDA_OFF, VDDB_OFF		7.5	8	8.5	V
$V_{VDDA_HYS}, V_{VDDB_HYS}$	Threshold hysteresis			0.5		V
PWM AND DISABLE						
V_{PWMH}, V_{DISH}	Input high voltage		1.6	1.8	2	V
V_{PWML}, V_{DISL}	Input low voltage		0.8	1	1.2	V
V_{PWM_HYS}, V_{DIS_HYS}	Input hysteresis			0.8		V
V_{PWM}	Negative transient, ref to GND, 50 ns pulse	Not production tested, bench test only	-5			V

$V_{VCCI} = 3.3\text{ V}$ or $V_{VCCI} = 5\text{ V}$, $0.1\text{-}\mu\text{F}$ capacitor from VCCI to GND, $V_{VDDA} = V_{VDDB} = 12\text{ V}$, $1\text{-}\mu\text{F}$ capacitor from VDDA and VDDB to VSSA and VSSB, $T_A = -40^\circ\text{C}$ to $+125^\circ\text{C}$, (unless otherwise noted)

PARAMETER		TEST CONDITIONS	MIN	TYP	MAX	UNIT
OUTPUT						
I_{OA+}, I_{OB+}	Peak output source current	$C_{VDD} = 10\ \mu\text{F}$, $C_{LOAD} = 0.18\ \mu\text{F}$, $f = 1\ \text{kHz}$, bench measurement		4		A
I_{OA-}, I_{OB-}	Peak output sink current	$C_{VDD} = 10\ \mu\text{F}$, $C_{LOAD} = 0.18\ \mu\text{F}$, $f = 1\ \text{kHz}$, bench measurement		6		A
R_{OHA}, R_{OHB}	Output resistance at high state	$I_{OUT} = -10\ \text{mA}$, $T_A = 25^\circ\text{C}$, R_{OHA} , R_{OHB} do not represent drive pull-up performance. See t_{RISE} in Section 6.10 and Section 8.3.4 for details.		5		Ω
R_{OLA}, R_{OLB}	Output resistance at low state	$I_{OUT} = 10\ \text{mA}$, $T_A = 25^\circ\text{C}$		0.55		Ω
V_{OHA}, V_{OHB}	Output voltage at high state	$V_{VDDA}, V_{VDDB} = 12\ \text{V}$, $I_{OUT} = -10\ \text{mA}$, $T_A = 25^\circ\text{C}$		11.95		V
V_{OLA}, V_{OLB}	Output voltage at low state	$V_{VDDA}, V_{VDDB} = 12\ \text{V}$, $I_{OUT} = 10\ \text{mA}$, $T_A = 25^\circ\text{C}$		5.5		mV
DEADTIME AND OVERLAP PROGRAMMING						
Dead time		Pull DT pin to VCCI		0		ns
		DT pin is left open, min spec characterized only, tested for outliers		8	15	ns
		$R_{DT} = 20\ \text{k}\Omega$	160	200	240	ns

6.10 Switching Characteristics

$V_{VCCI} = 3.3\text{ V}$ or 5 V , $0.1\text{-}\mu\text{F}$ capacitor from VCCI to GND, $V_{VDDA} = V_{VDDB} = 12\text{ V}$, $1\text{-}\mu\text{F}$ capacitor from VDDA and VDDB to VSSA and VSSB, $T_A = -40^\circ\text{C}$ to $+125^\circ\text{C}$, (unless otherwise noted).

PARAMETER		TEST CONDITIONS	MIN	TYP	MAX	UNIT
t_{RISE}	Output rise time, 20% to 80% measured points	$C_{OUT} = 1.8\ \text{nF}$		6	16	ns
t_{FALL}	Output fall time, 90% to 10% measured points	$C_{OUT} = 1.8\ \text{nF}$		7	12	ns
t_{PWmin}	Minimum pulse width	Output off for less than minimum, $C_{OUT} = 0\ \text{pF}$			20	ns
t_{PDHL}	Propagation delay from INx to OUTx falling edges			19	30	ns
t_{PDLH}	Propagation delay from INx to OUTx rising edges			19	30	ns
t_{PWD}	Pulse width distortion $ t_{PDLH} - t_{PDHL} $				6	ns
t_{DM}	Propagation delays matching between VOUTA, VOUTB	$f = 100\ \text{kHz}$			5	ns
CMTI	Static common-mode transient immunity (See Section 7.5)	Slew rate of GND versus VSSA and VSSB, PWM is tied to GND or VCCI	100			V/ns

6.11 Insulation Characteristics Curves

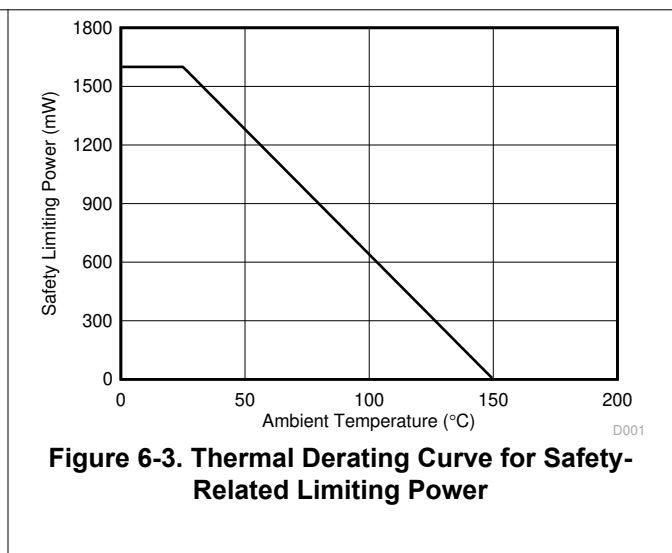
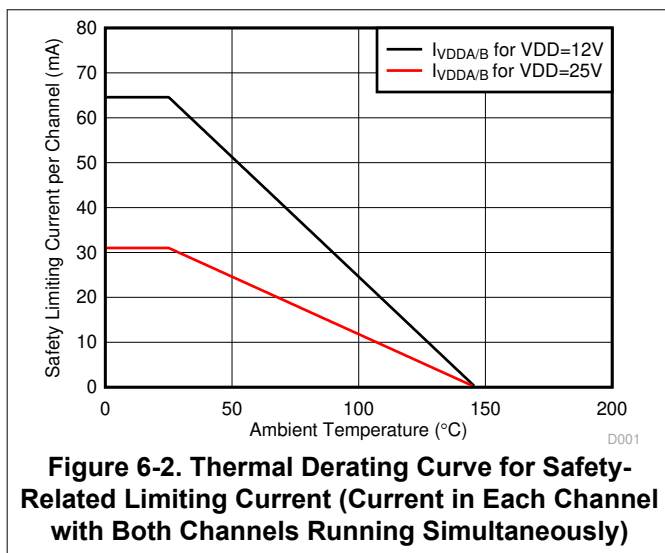
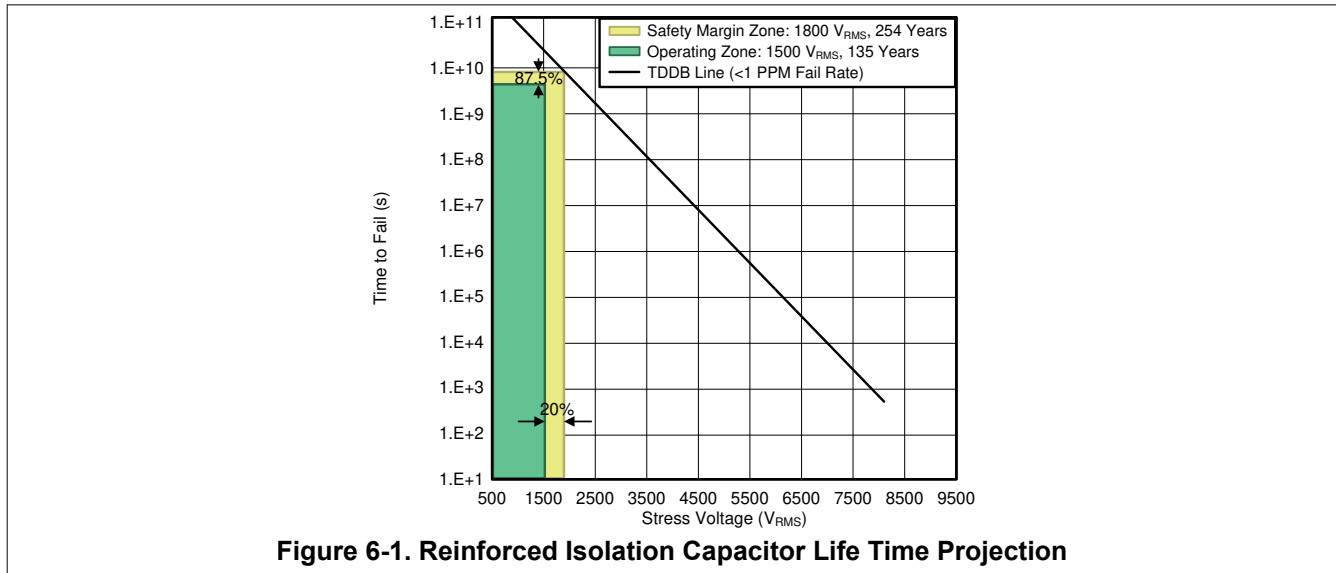

6.12 Typical Characteristics

VDDA = VDDB= 12 V, VCCI = 3.3 V, T_A = 25°C, No load unless otherwise noted.

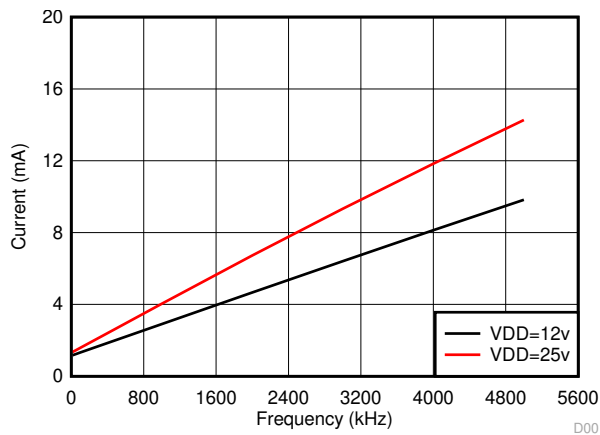

No load

Figure 6-4. Per Channel Current Consumption vs. Frequency

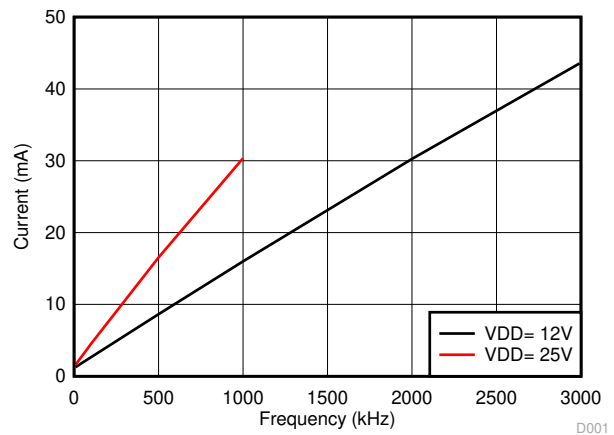

C_{LOAD} = 1 nF

Figure 6-5. Per Channel Current Consumption (I_{VDDA/B}) vs. Frequency

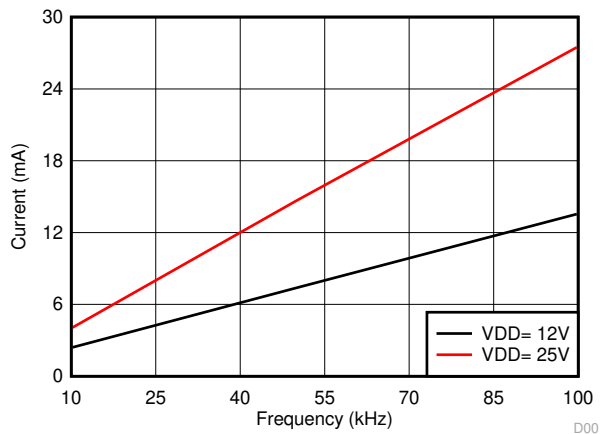

C_{LOAD} = 10 nF

Figure 6-6. Per Channel Current Consumption (I_{VDDA/B}) vs. Frequency

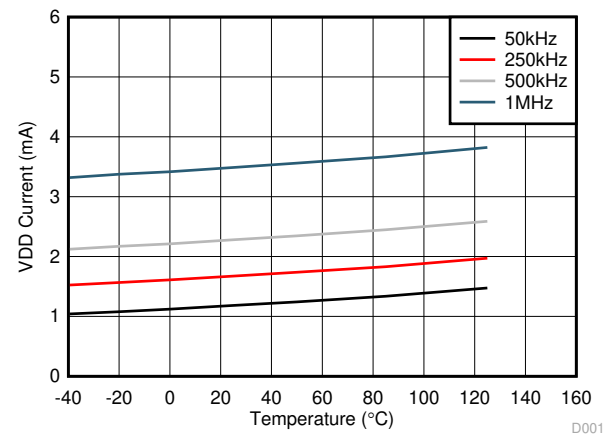

No load

Figure 6-7. Per Channel (I_{VDDA/B}) Supply Current Vs. Temperature

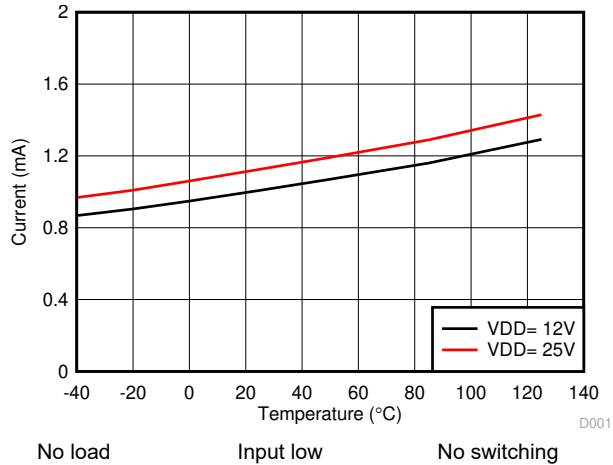

Figure 6-8. Per Channel ($I_{VDDA/B}$) Quiescent Supply Current vs Temperature

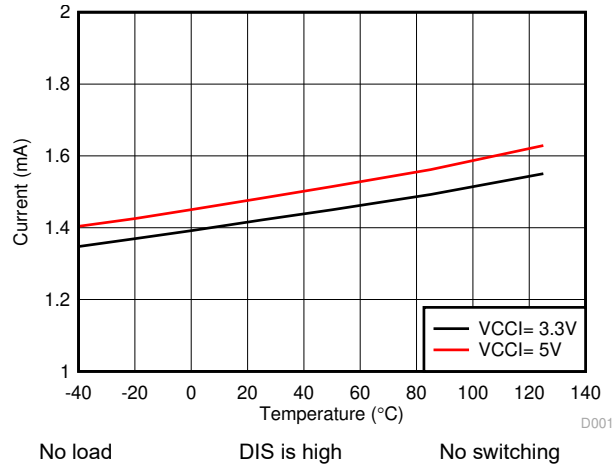

Figure 6-9. I_{VCCI} Quiescent Supply Current vs Temperature

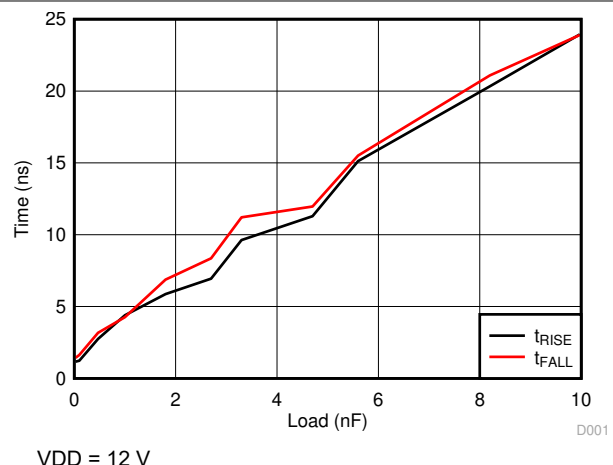

Figure 6-10. Rising and Falling Times vs. Load

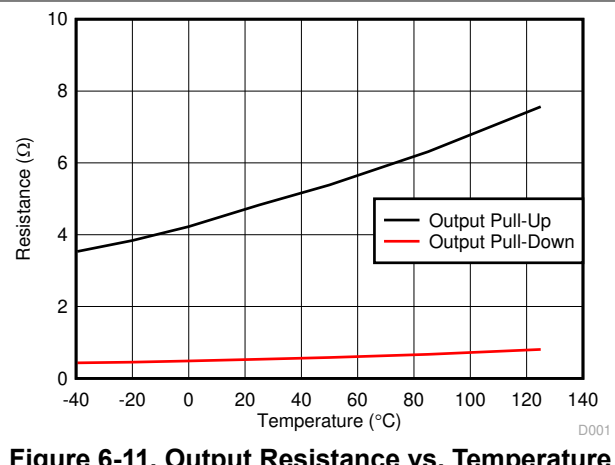

Figure 6-11. Output Resistance vs. Temperature

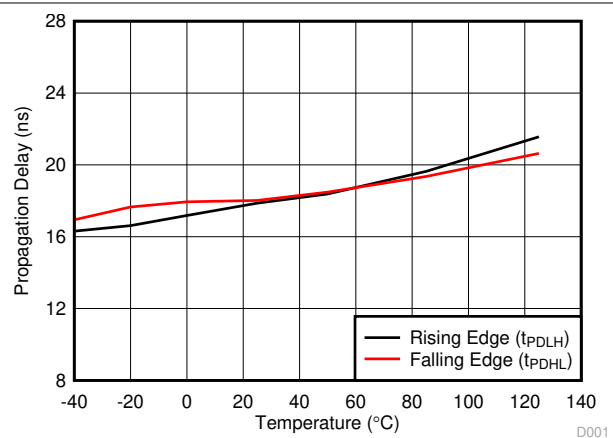

Figure 6-12. Propagation Delay vs. Temperature

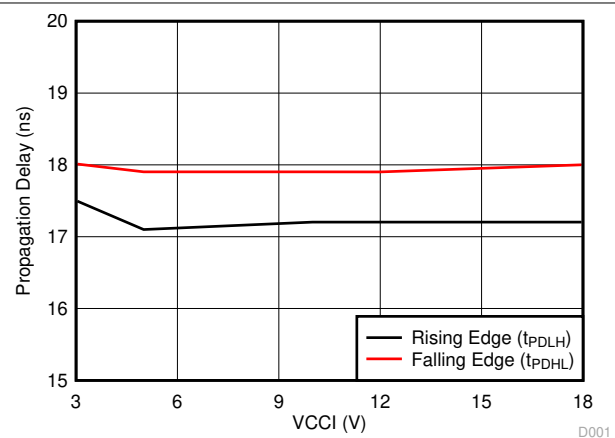
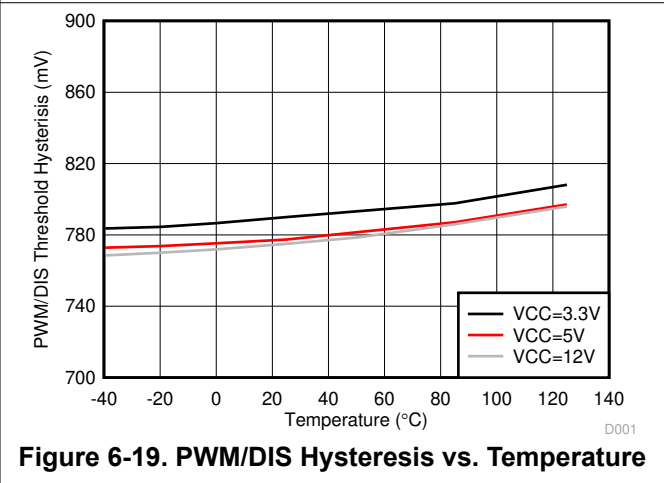
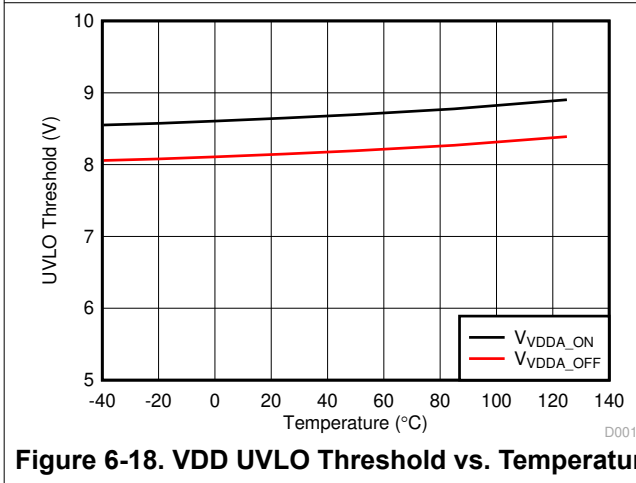
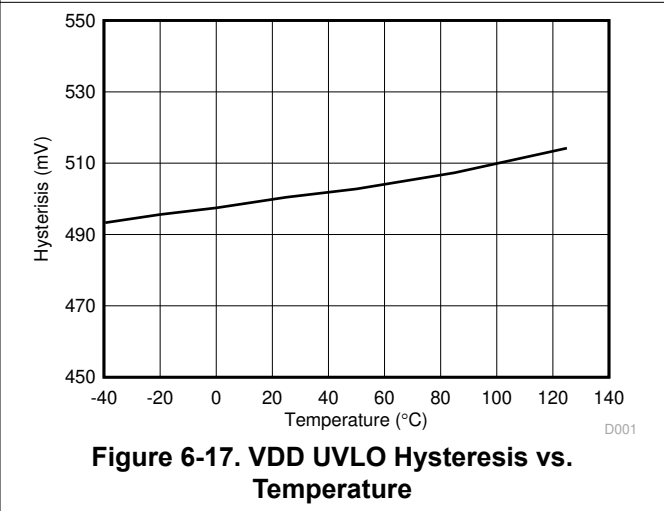
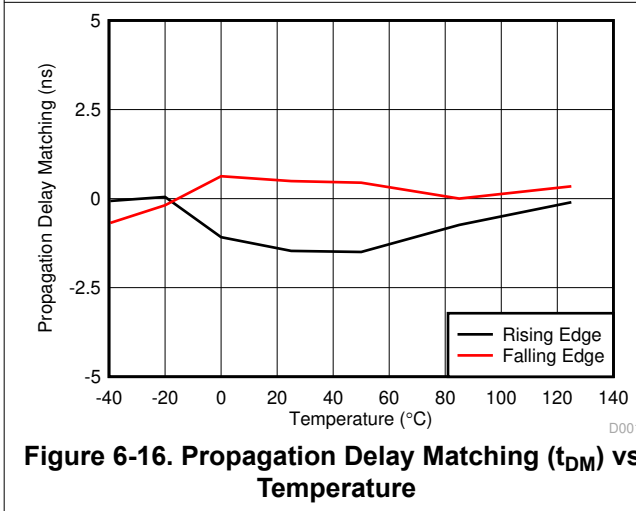
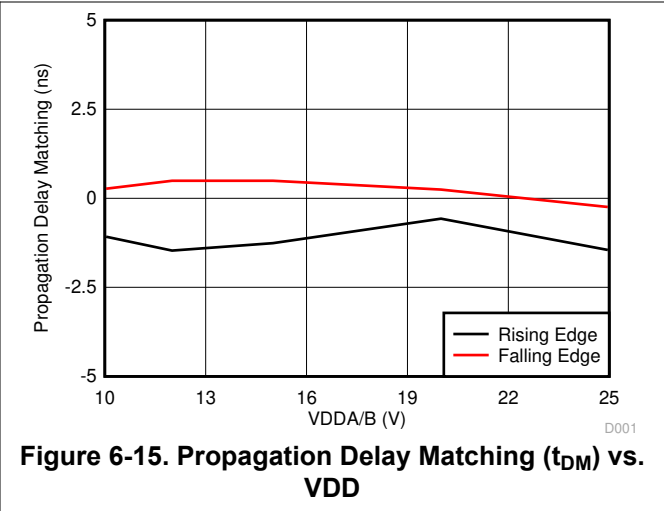
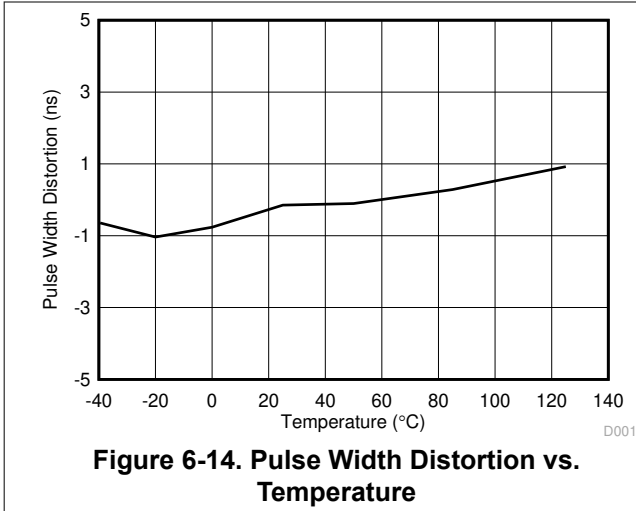

Figure 6-13. Propagation Delay vs. VCCI



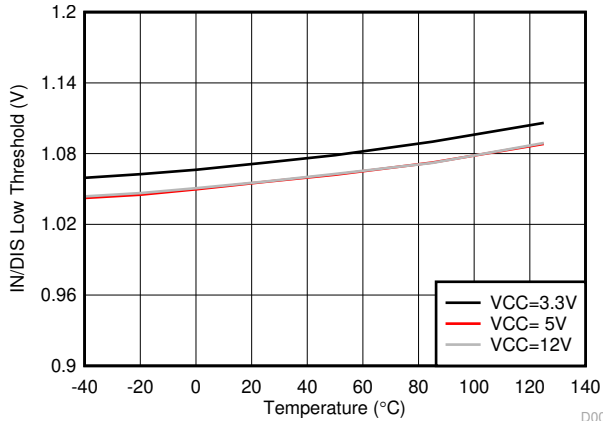

Figure 6-20. PWM/DIS Low Threshold

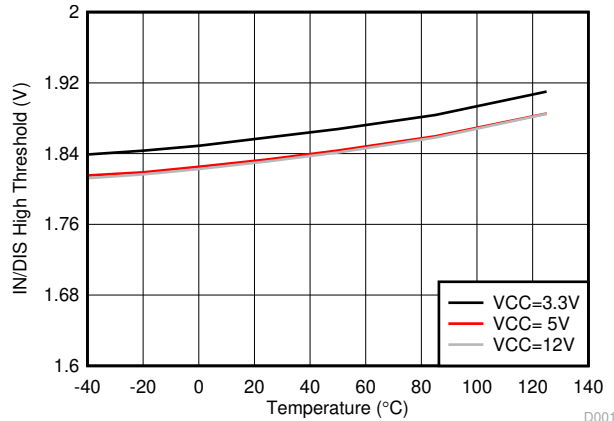

Figure 6-21. PWM/DIS High Threshold

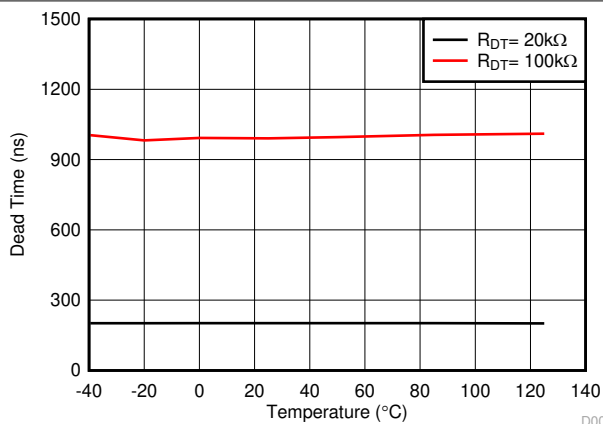

Figure 6-22. Dead Time vs. Temperature

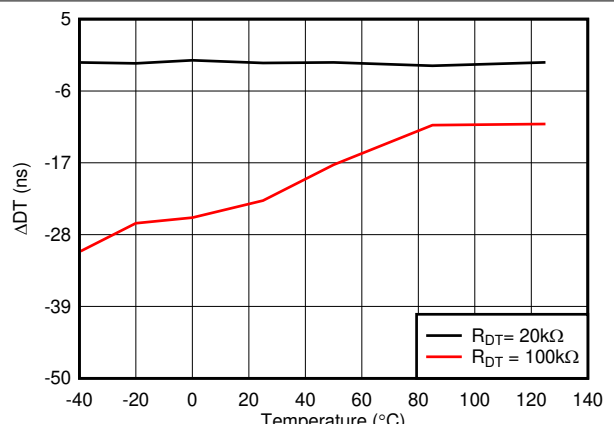

Figure 6-23. Dead Time Matching vs. Temperature

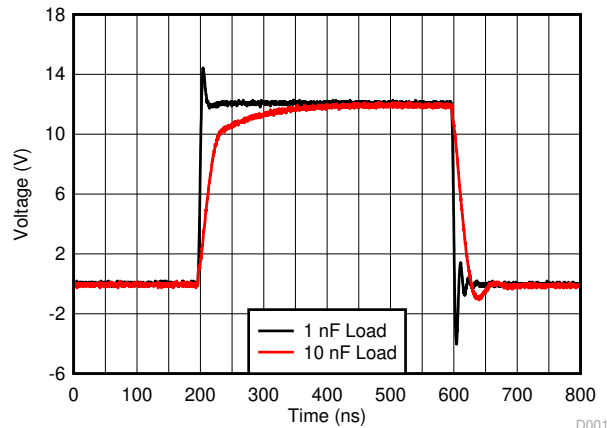

Figure 6-24. Typical Output Voltage

7 Parameter Measurement Information

7.1 Propagation Delay and Pulse Width Distortion

Figure 7-1 shows how one calculates pulse width distortion (t_{PWD}) and delay matching (t_{DM}) from the propagation delays of channels A and B. It can be measured by disabling the dead time function by shorting the DT Pin to VCC.

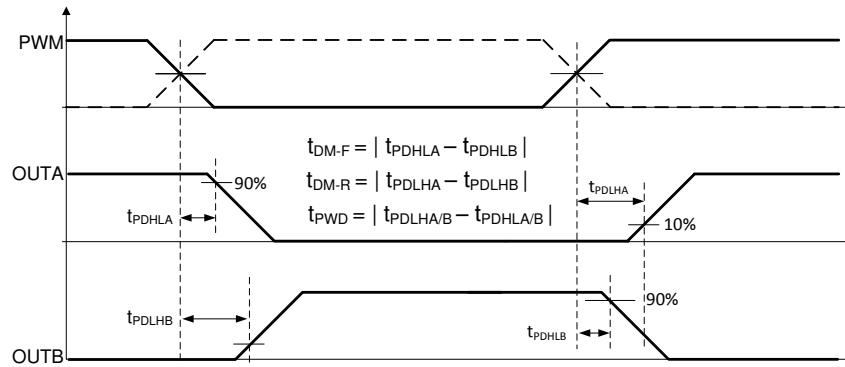

Figure 7-1. Propagation Delay Matching and Pulse Width Distortion

7.2 Rising and Falling Time

Figure 7-2 shows the criteria for measuring rising (t_{RISE}) and falling (t_{FALL}) times. For more information on how short rising and falling times are achieved see Section 8.3.4

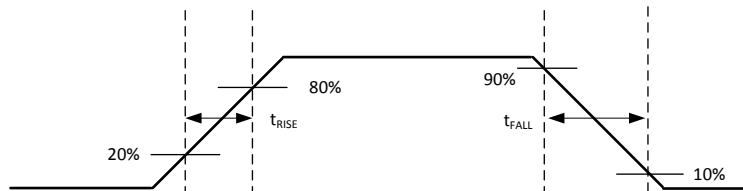

Figure 7-2. Rising and Falling Time Criteria

7.3 PWM Input and Disable Response Time

Figure 7-3 shows the response time of the disable function. For more information, see Section 8.4.1 .

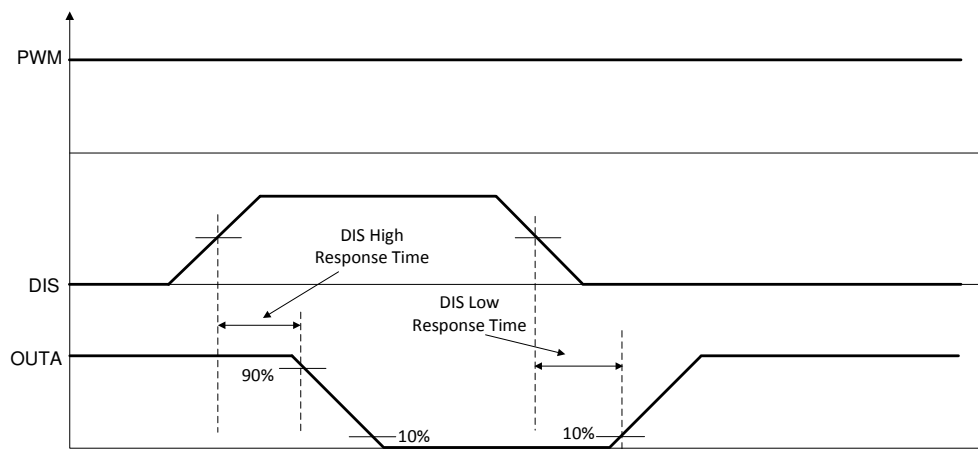

Figure 7-3. Disable Pin Timing

7.4 Programmable Dead Time

Leaving the DT pin open or tying it to GND through an appropriate resistor (R_{DT}) sets a dead-time interval. For more details on dead time, refer to [Section 8.4.2](#).

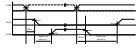
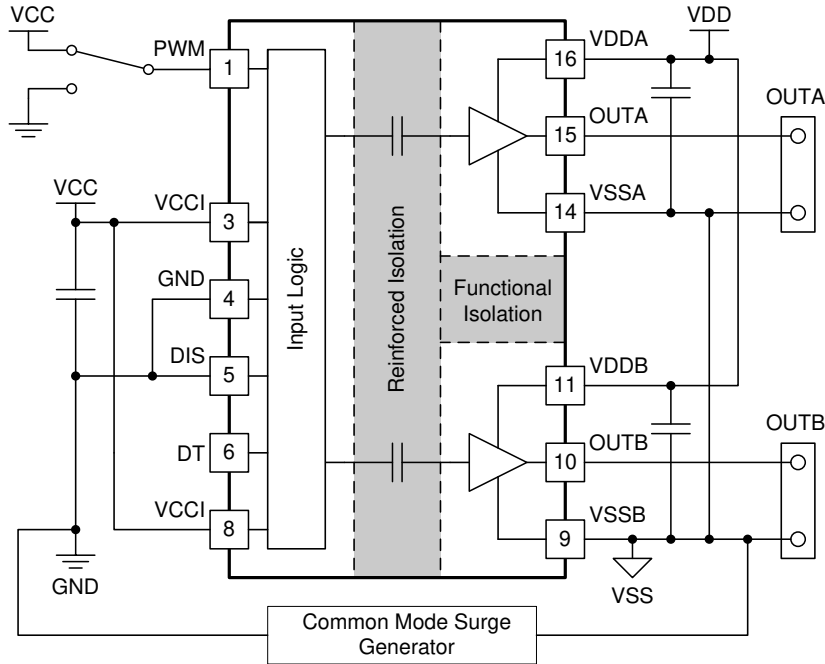

Figure 7-4. Dead-Time Switching Parameters

7.5 CMTI Testing

Figure 7-5 is a simplified diagram of the CMTI testing configuration.



Copyright © 2016, Texas Instruments Incorporated

Figure 7-5. Simplified CMTI Testing Setup

8 Detailed Description

8.1 Overview

In order to switch power transistors rapidly and reduce switching power losses, high-current gate drivers are often placed between the output of control devices and the gates of power transistors. There are several instances where controllers are not capable of delivering sufficient current to drive the gates of power transistors. This is especially the case with digital controllers, since the input signal from the digital controller is often a 3.3-V logic signal capable of only delivering a few mA.

The UCC20520 is a flexible dual gate driver which can be configured to fit a variety of power supply and motor drive topologies, as well as drive several types of transistors, including SiC MOSFETs. UCC20520 has many features that allow it to integrate well with control circuitry and protect the gates it drives such as: resistor-programmable dead time (DT) control, a DISABLE pin, and under voltage lock out (UVLO) for both input and output voltages. The UCC20520 also holds its OUTA low when the PWM is left open or when the PWM pulse is not wide enough. The driver input PWM is CMOS and TTL compatible for interfacing to digital and analog power controllers alike. Importantly, Channel A is in phase with PWM input and Channel B is always complimentary with Channel A with programmed deadtime.

8.2 Functional Block Diagram

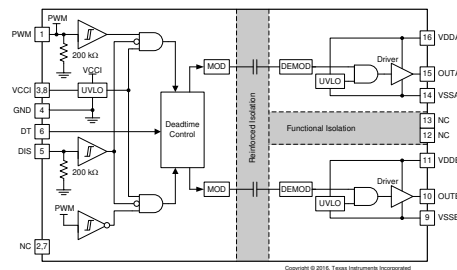

8.3 Feature Description

8.3.1 VDD, VCCI, and Under Voltage Lock Out (UVLO)

The UCC20520 has an internal under voltage lock out (UVLO) protection feature on the supply circuit blocks between the VDD and VSS pins for both outputs. When the VDD bias voltage is lower than V_{VDD_ON} at device start-up or lower than V_{VDD_OFF} after start-up, the VDD UVLO feature holds the effected outputs low, regardless of the status of the input pin (PWM).

When the output stages of the driver are in an unbiased or UVLO condition, the driver outputs are held low by an active clamp circuit that limits the voltage rise on the driver outputs (Illustrated in Figure 8-1). In this condition, the upper PMOS is resistively held off by R_{HI_Z} while the lower NMOS gate is tied to the driver output through R_{CLAMP} . In this configuration, the output is effectively clamped to the threshold voltage of the lower NMOS device, typically less than 1.5V, when no bias power is available.

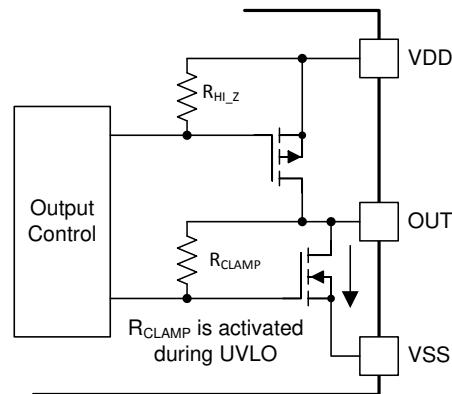

Figure 8-1. Simplified Representation of Active Pull Down Feature

The VDD UVLO protection has a hysteresis feature (V_{VDD_HYS}). This hysteresis prevents chatter when there is ground noise from the power supply. Also this allows the device to accept small drops in bias voltage, which is bound to happen when the device starts switching and operating current consumption increases suddenly.

The input side of the UCC20520 also has an internal under voltage lock out (UVLO) protection feature. The device isn't active unless the voltage, VCCI, is going to exceed V_{VCCI_ON} on start up. And a signal will cease to be delivered when that pin receives a voltage less than V_{VCCI_OFF} . And, just like the UVLO for VDD, there is hysteresis (V_{VCCI_HYS}) to ensure stable operation.

All versions of the UCC20520 can withstand an absolute maximum of 30 V for VDD, and 20 V for VCCI.

Table 8-1. UCC20520 VCCI UVLO Feature Logic

CONDITION	INPUT	OUTPUTS	
	PWM	OUTA	OUTB
VCCI-GND < V _{VCCI_ON} during device start up	H	L	L
VCCI-GND < V _{VCCI_ON} during device start up	L	L	L
VCCI-GND < V _{VCCI_OFF} after device start up	H	L	L
VCCI-GND < V _{VCCI_OFF} after device start up	L	L	L

Table 8-2. UCC20520 VDD UVLO Feature Logic

CONDITION	INPUT	OUTPUTS	
	PWM	OUTA	OUTB
VDD-VSS < V _{VDD_ON} during device start up	H	L	L
VDD-VSS < V _{VDD_ON} during device start up	L	L	L
VDD-VSS < V _{VDD_OFF} after device start up	H	L	L
VDD-VSS < V _{VDD_OFF} after device start up	L	L	L

8.3.2 Input and Output Logic Table

Table 8-3. INPUT/OUTPUT Logic Table⁽¹⁾

Assume VCCI, VDDA, VDDDB are powered up. See [Section 8.3.1](#) for more information on UVLO operation modes.

INPUT PWM	DISABLE	OUTPUTS		NOTE
		OUTA	OUTB	
L or Left Open	L or Left Open	L	H	Output transitions occur after the dead time expires. See Section 8.4.2
H	L or Left Open	H	L	
X	H	L	L	-

(1) "X" means L, H or left open.

8.3.3 Input Stage

The input pins (PWM and DIS) of UCC20520 are based on a TTL and CMOS compatible input-threshold logic that is totally isolated from the VDD supply voltage. The input pins are easy to drive with logic-level control signals (Such as those from 3.3-V micro-controllers), since UCC20520 has a typical high threshold (V_{PWMH}) of 1.8 V and a typical low threshold of 1 V, which vary little with temperature (see [Figure 6-20](#), [Figure 6-21](#)). A wide hysteresis (V_{PWM_HYS}) of 0.8 V makes for good noise immunity and stable operation. If any of the inputs are ever left open, internal pull-down resistors force the pin low. These resistors are typically 200 kΩ (See [Section 8.2](#)). However, it is still recommended to ground an input if it is not being used.

Since the input side of UCC20520 is isolated from the output drivers, the input signal amplitude can be larger or smaller than VDD, provided that it doesn't exceed the recommended limit. This allows greater flexibility when integrating with control signal sources, and allows the user to choose the most efficient VDD for their chosen gate. That said, the amplitude of any signal applied to PWM must *never* be at a voltage higher than VCCI.

8.3.4 Output Stage

The UCC20520's output stages features a pull-up structure which delivers the highest peak-source current when it is most needed, during the Miller plateau region of the power-switch turn on transition (when the power switch drain or collector voltage experiences dV/dt). The output stage pull-up structure features a P-channel MOSFET and an additional *Pull-Up* N-channel MOSFET in parallel. The function of the N-channel MOSFET is to provide a brief boost in the peak-sourcing current, enabling fast turn on. This is accomplished by briefly turning on the N-channel MOSFET during a narrow instant when the output is changing states from low to high. The on-resistance of this N-channel MOSFET (R_{NMOS}) is approximately $1.47\ \Omega$ when activated.

The R_{OH} parameter is a DC measurement and it is representative of the on-resistance of the P-channel device only. This is because the *Pull-Up* N-channel device is held in the off state in DC condition and is turned on only for a brief instant when the output is changing states from low to high. Therefore the effective resistance of the UCC20520 pull-up stage during this brief turn-on phase is much lower than what is represented by the R_{OH} parameter. Therefore, the value of R_{OH} belies the fast nature of the UCC20520's turn-on time.

The pull-down structure in UCC20520 is simply composed of an N-channel MOSFET. The R_{OL} parameter, which is also a DC measurement, is representative of the impedance of the pull-down state in the device. Both outputs of the UCC20520 are capable of delivering 4-A peak source and 6-A peak sink current pulses. The output voltage swings between VDD and VSS provides rail-to-rail operation, thanks to the MOS-out stage which delivers very low drop-out.

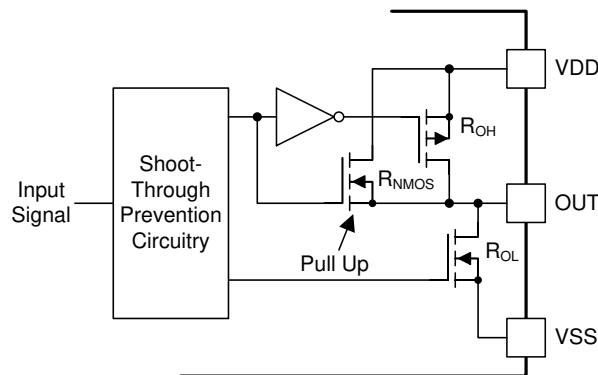

Figure 8-2. Output Stage

8.3.5 Diode Structure in UCC20520

Figure 8-3 illustrates the multiple diodes involved in the ESD protection components of the UCC20520. This provides a pictorial representation of the absolute maximum rating for the device.

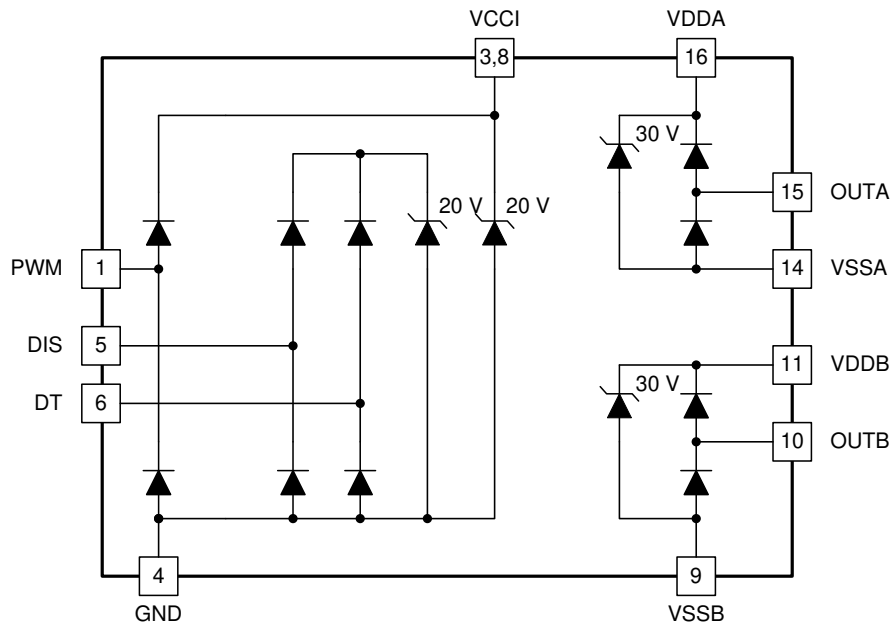

Figure 8-3. ESD Structure

8.4 Device Functional Modes

8.4.1 Disable Pin

Setting the DISABLE pin high shuts down both outputs simultaneously. Grounding (or left open) the DISABLE pin allows UCC20520 to operate normally. The DISABLE response time is in the range of 20ns and quite responsive, which is as fast as propagation delay. The DISABLE pin is only functional (and necessary) when VCCI stays above the UVLO threshold. It is recommended to tie this pin to ground if the DISABLE pin is not used to achieve better noise immunity.

8.4.2 Programmable Dead Time (DT) Pin

UCC20520 allows the user to adjust dead time (DT) in the following ways:

8.4.2.1 Tying the DT Pin to VCC

If DT pin is tied to VCC, dead time function between OUTA and OUTB is disabled and the deadtime between the two output channels is around 0ns.

8.4.2.2 DT Pin Left Open or Connected to a Programming Resistor between DT and GND Pins

If the DT pin is left open, the dead time duration (t_{DT}) is set to <15 ns. One can program t_{DT} by placing a resistor, R_{DT} , between the DT pin and GND. The appropriate R_{DT} value can be determined from Equation 1, where R_{DT} is in $k\Omega$ and t_{DT} in ns:

8.4.2.3

$$t_{DT} \approx 10 \times R_{DT} \quad (1)$$

The steady state voltage at DT pin is around 0.8V, and the DT pin current will be less than 10uA when $R_{DT}=100k\Omega$. Therefore, It is recommended to parallel a ceramic capacitor, 2.2nF or above, with R_{DT} to achieve better noise immunity and better deadtime matching between two channels, especially when the dead time is larger than 300ns. The major consideration is that the current through the R_{DT} is used to set the dead time, and this current decreases as R_{DT} increases.

PWM input signal's falling edge activates the programmed dead time for the other signal. The output signals' dead time is always set to the driver's programmed dead time. Various driver dead time logic operating conditions are illustrated and explained in Figure 8-4:

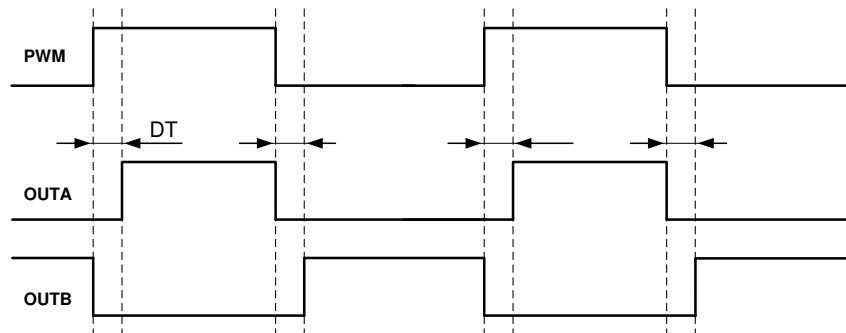

Figure 8-4. Input and Output Logic Relationship with Dead Time

9 Application and Implementation

Note

Information in the following applications sections is not part of the TI component specification, and TI does not warrant its accuracy or completeness. TI's customers are responsible for determining suitability of components for their purposes, as well as validating and testing their design implementation to confirm system functionality.

9.1 Application Information

The UCC20520 effectively combines both isolation and buffer-drive functions. The flexible, universal capability of the UCC20520 (with up to 18-V VCCI and 25-V VDDA/VDDB) allows the device to be used as a low-side, high-side, high-side/low-side or half-bridge driver for MOSFETs, IGBTs or SiC MOSFETs. With integrated components, advanced protection features (UVLO, dead time, and disable) and optimized switching performance; the UCC20520 enables designers to build smaller, more robust designs for enterprise, telecom, automotive, and industrial applications with a faster time to market.

9.2 Typical Application

Figure 9-1 shows a reference design with UCC20520 driving a typical half-bridge configuration which can be used in several popular power converter topologies such as synchronous buck, synchronous boost, half-bridge/full bridge isolated topologies, and three-phase motor drive applications.

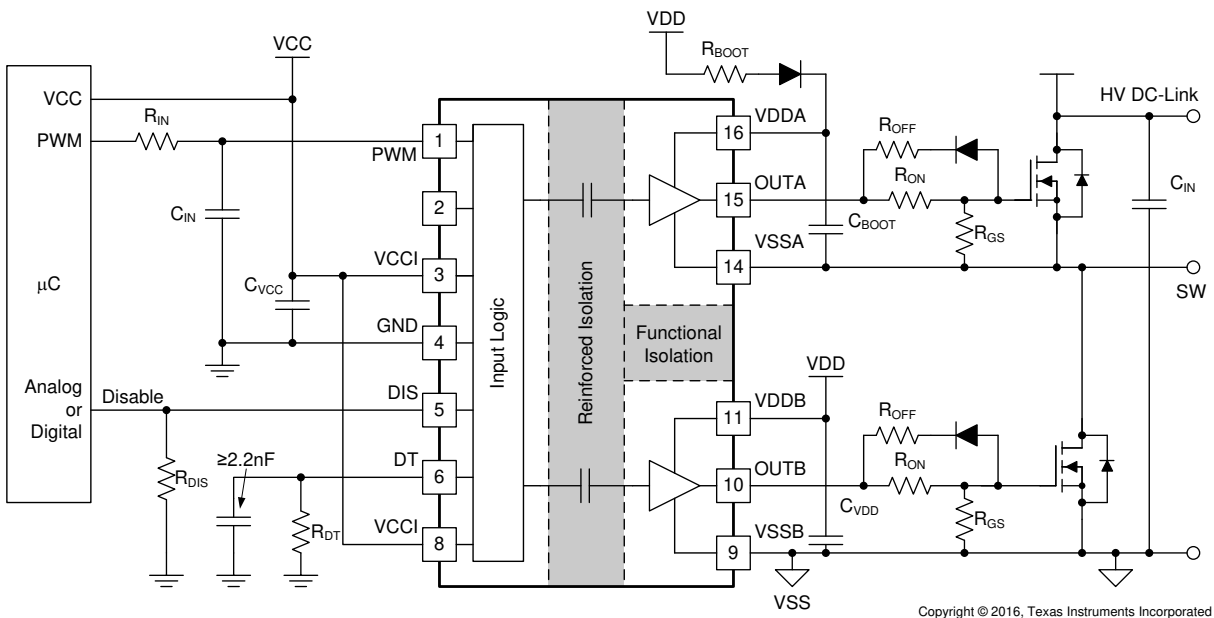

Figure 9-1. Typical Application

9.2.1 Design Requirements

Table 9-1 lists reference design parameters for the example application: UCC20520 driving 1200-V SiC-MOSFETs in a high side-low side configuration.

Table 9-1. UCC20520 Design Requirements

PARAMETER	VALUE	UNITS
Power transistor	C2M0080120D	-
VCC	5.0	V
VDD	20	V
Input signal amplitude	0 ↔ 3.3	V
Switching frequency (f_s)	100	kHz
DC link voltage	800	V

9.2.2 Detailed Design Procedure

9.2.2.1 Designing PWM Input Filter

It is recommended that users avoid shaping the signals to the gate driver in an attempt to slow down (or delay) the signal at the output. However, a small input R_{IN} - C_{IN} filter can be used to filter out the ringing introduced by non-ideal layout or long PCB traces.

Such a filter should use an R_{IN} in the range of 0 Ω to 100 Ω and a C_{IN} between 10 pF and 100 pF. In the example, an $R_{IN} = 51 \Omega$ and a $C_{IN} = 33$ pF are selected, with a corner frequency of approximately 100 MHz.

When selecting these components, it is important to pay attention to the trade-off between good noise immunity and propagation delay.

9.2.2.2 Select External Bootstrap Diode and its Series Resistor

The bootstrap capacitor is charged by VDD through an external bootstrap diode every cycle when the low side transistor turns on. Charging the capacitor involves high-peak currents, and therefore transient power dissipation in the bootstrap diode may be significant. Conduction loss also depends on the diode's forward voltage drop. Both the diode conduction losses and reverse recovery losses contribute to the total losses in the gate driver circuit.

When selecting external bootstrap diodes, it is recommended that one choose high voltage, fast recovery diodes or SiC Schottky diodes with a low forward voltage drop and low junction capacitance in order to minimize the loss introduced by reverse recovery and related grounding noise bouncing. In the example, the DC-link voltage is 800 V_{DC}. The voltage rating of the bootstrap diode should be higher than the DC-link voltage with a good margin. Therefore, a 1200-V SiC diode, C4D02120E, is chosen in this example.

A bootstrap resistor, R_{BOOT} , is used to reduce the inrush current in D_{BOOT} and limit the ramp up slew rate of voltage of VDDA-VSSA during each switching cycle, especially when the VSSA(SW) pin has an excessive negative transient voltage. The recommended value for R_{BOOT} is between 1 Ω and 20 Ω depending on the diode used. In the example, a current limiting resistor of 2.2 Ω is selected to limit the inrush current of bootstrap diode. The estimated worst case peak current through D_{Boot} is,

$$I_{D_{Boot}(pk)} = \frac{V_{DD} - V_{BDF}}{R_{Boot}} = \frac{20V - 2.5V}{2.2\Omega} \approx 8A \quad (2)$$

where

- V_{BDF} is the estimated bootstrap diode forward voltage drop at 8 A.

9.2.2.3 Gate Driver Output Resistor

The external gate driver resistors, R_{ON}/R_{OFF} , are used to:

1. Limit ringing caused by parasitic inductances/capacitances.
2. Limit ringing caused by high voltage/current switching dv/dt , di/dt , and body-diode reverse recovery.
3. Fine-tune gate drive strength, i.e. peak sink and source current to optimize the switching loss.
4. Reduce electromagnetic interference (EMI).

As mentioned in [Section 8.3.4](#), the UCC20520 has a pull-up structure with a P-channel MOSFET and an additional *pull-up* N-channel MOSFET in parallel. The combined peak source current is 4 A. Therefore, the peak source current can be predicted with:

$$I_{OA+} = \min\left(4A, \frac{V_{DD} - V_{BDF}}{R_{NMOS} \parallel R_{OH} + R_{ON} + R_{GFET_Int}}\right) \quad (3)$$

$$I_{OB+} = \min\left(4A, \frac{V_{DD}}{R_{NMOS} \parallel R_{OH} + R_{ON} + R_{GFET_Int}}\right) \quad (4)$$

where

- R_{ON} : External turn-on resistance.
- R_{GFET_INT} : Power transistor internal gate resistance, found in the power transistor datasheet.
- I_{O+} = Peak source current – The minimum value between 4 A, the gate driver peak source current, and the calculated value based on the gate drive loop resistance.

In this example:

$$I_{OA+} = \frac{V_{DD} - V_{BDF}}{R_{NMOS} \parallel R_{OH} + R_{ON} + R_{GFET_Int}} = \frac{20V - 0.8V}{1.47\Omega \parallel 5\Omega + 2.2\Omega + 4.6\Omega} \approx 2.4A \quad (5)$$

$$I_{OB+} = \frac{V_{DD}}{R_{NMOS} \parallel R_{OH} + R_{ON} + R_{GFET_Int}} = \frac{20V}{1.47\Omega \parallel 5\Omega + 2.2\Omega + 4.6\Omega} \approx 2.5A \quad (6)$$

Therefore, the high-side and low-side peak source current is 2.4 A and 2.5 A respectively. Similarly, the peak sink current can be calculated with:

$$I_{OA-} = \min\left(6A, \frac{V_{DD} - V_{BDF} - V_{GDF}}{R_{OL} + R_{OFF} \parallel R_{ON} + R_{GFET_Int}}\right) \quad (7)$$

$$I_{OB-} = \min\left(6A, \frac{V_{DD} - V_{GDF}}{R_{OL} + R_{OFF} \parallel R_{ON} + R_{GFET_Int}}\right) \quad (8)$$

where

- R_{OFF} : External turn-off resistance;
- V_{GDF} : The anti-parallel diode forward voltage drop which is in series with R_{OFF} . The diode in this example is an MSS1P4.
- I_{O-} : Peak sink current – the minimum value between 6 A, the gate driver peak sink current, and the calculated value based on the gate drive loop resistance.

In this example,

$$I_{OA-} = \frac{V_{DD} - V_{BDF} - V_{GDF}}{R_{OL} + R_{OFF} \parallel R_{ON} + R_{GFET_Int}} = \frac{20V - 0.8V - 0.75V}{0.55\Omega + 0\Omega + 4.6\Omega} \approx 3.6A \quad (9)$$

$$I_{OB-} = \frac{V_{DD} - V_{GDF}}{R_{OL} + R_{OFF} \parallel R_{ON} + R_{GFET_Int}} = \frac{20V - 0.75V}{0.55\Omega + 0\Omega + 4.6\Omega} \approx 3.7A \quad (10)$$

Therefore, the high-side and low-side peak sink current is 3.6 A and 3.7 A respectively.

Importantly, the estimated peak current is also influenced by PCB layout and load capacitance. Parasitic inductance in the gate driver loop can slow down the peak gate drive current and introduce overshoot and undershoot. Therefore, it is strongly recommended that the gate driver loop should be minimized. On the other hand, the peak source/sink current is dominated by loop parasitics when the load capacitance (C_{ISS}) of the power transistor is very small (typically less than 1 nF), because the rising and falling time is too small and close to the parasitic ringing period.

9.2.2.4 Estimate Gate Driver Power Loss

The total loss, P_G , in the gate driver subsystem includes the power losses of the UCC20520 (P_{GD}) and the power losses in the peripheral circuitry, such as the external gate drive resistor. Bootstrap diode loss is not included in P_G and not discussed in this section.

P_{GD} is the key power loss which determines the thermal safety-related limits of the UCC20520, and it can be estimated by calculating losses from several components.

The first component is the static power loss, P_{GDQ} , which includes quiescent power loss on the driver as well as driver self-power consumption when operating with a certain switching frequency. P_{GDQ} is measured on the bench with no load connected to OUTA and OUTB at a given V_{CCI} , V_{DDA}/V_{DDB} , switching frequency and ambient temperature. Figure 6-4 shows the per output channel current consumption vs. operating frequency with no load. In this example, $V_{VCCI} = 5V$ and $V_{VDD} = 20V$. The current on each power supply, with PWM switching from 0 V to 3.3 V at 100 kHz is measured to be $I_{VCCI} = 2.5mA$, and $I_{VDDA} = I_{VDDB} = 1.5mA$. Therefore, the P_{GDQ} can be calculated with

$$P_{GDQ} = V_{VCCI} \times I_{VCCI} + V_{VDDA} \times I_{DDA} + V_{VDDB} \times I_{DDB} \approx 72mW \quad (11)$$

The second component is switching operation loss, P_{GDO} , with a given load capacitance which the driver charges and discharges the load during each switching cycle. Total dynamic loss due to load switching, P_{GSW} , can be estimated with

$$P_{GSW} = 2 \times V_{DD} \times Q_G \times f_{SW} \quad (12)$$

where

- Q_G is the gate charge of the power transistor.

If a split rail is used to turn on and turn off, then V_{DD} is going to be equal to difference between the positive rail to the negative rail.

So, for this example application:

$$P_{GSW} = 2 \times 20V \times 60nC \times 100kHz = 240mW \quad (13)$$

Q_G represents the total gate charge of the power transistor switching 800 V at 20 A, and is subject to change with different testing conditions. The UCC20520 gate driver loss on the output stage, P_{GDO} , is part of P_{GSW} . P_{GDO} will be equal to P_{GSW} if the external gate driver resistances are zero, and all the gate driver loss is dissipated inside the UCC20520. If there are external turn-on and turn-off resistance, the total loss will be distributed between the gate driver pull-up/down resistances and external gate resistances. Importantly, the pull-up/down resistance is a linear and fixed resistance if the source/sink current is not saturated to 4 A/6 A, however, it will be non-linear if the source/sink current is saturated. Therefore, P_{GDO} is different in these two scenarios.

Case 1 - Linear Pull-Up/Down Resistor:

$$P_{GDO} = P_{GSW} \times \left(\frac{R_{OH} \parallel R_{NMOS}}{R_{OH} \parallel R_{NMOS} + R_{ON} + R_{GFET_Int}} + \frac{R_{OL}}{R_{OL} + R_{OFF} \parallel R_{ON} + R_{GFET_Int}} \right) \quad (14)$$

In this design example, all the predicted source/sink currents are less than 4 A/6 A, therefore, the UCC20520 gate driver loss can be estimated with:

$$P_{GDO} = 240\text{mW} \times \left(\frac{5\Omega \parallel 1.47\Omega}{5\Omega \parallel 1.47\Omega + 2.2\Omega + 4.6\Omega} + \frac{0.55\Omega}{0.55\Omega + 0\Omega + 4.6\Omega} \right) \approx 60\text{mW} \quad (15)$$

Case 2 - Nonlinear Pull-Up/Down Resistor:

$$P_{GDO} = 2 \times f_{SW} \times \left[4\text{A} \times \int_0^{T_{R_Sys}} (V_{DD} - V_{OUTA/B}(t)) dt + 6\text{A} \times \int_0^{T_{F_Sys}} V_{OUTA/B}(t) dt \right] \quad (16)$$

where

- $V_{OUTA/B}(t)$ is the gate driver OUTA and OUTB pin voltage during the turn on and off transient, and it can be simplified that a constant current source (4 A at turn-on and 6 A at turn-off) is charging/discharging a load capacitor. Then, the $V_{OUTA/B}(t)$ waveform will be linear and the T_{R_Sys} and T_{F_Sys} can be easily predicted.

For some scenarios, if only one of the pull-up or pull-down circuits is saturated and another one is not, the P_{GDO} will be a combination of Case 1 and Case 2, and the equations can be easily identified for the pull-up and pull-down based on the above discussion. Therefore, total gate driver loss dissipated in the gate driver UCC20520, P_{GD} , is:

$$P_{GD} = P_{GDQ} + P_{GDO} \quad (17)$$

which is equal to 127 mW in the design example.

9.2.2.5 Estimating Junction Temperature

The junction temperature (T_J) of the UCC20520 can be estimated with:

$$T_J = T_C + R_{\theta JC} \times P_{GD} \quad (18)$$

where

- T_C is the UCC20520 case-top temperature measured with a thermocouple or some other instrument, $R_{\theta JC}$ is the Junction-to-case-top thermal resistance from the [Section 6.4](#) table. Importantly, $R_{\theta JA}$, the junction to ambient thermal impedance provided in the Thermal Information table, is developed based on JEDEC standard PCB board and it is subject to change when the PCB board layout is different.

9.2.2.6 Selecting VCCI, VDDA/B Capacitor

Bypass capacitors for VCCI, VDDA, and VDDB are essential for achieving reliable performance. It is recommended that one choose low ESR and low ESL surface-mount multi-layer ceramic capacitors (MLCC) with sufficient voltage ratings, temperature coefficients and capacitance tolerances. Importantly, DC bias on an MLCC will impact the actual capacitance value. For example, a 25-V, 1- μ F X7R capacitor is measured to be only 500 nF when a DC bias of 15 V_{DC} is applied.

9.2.2.6.1 Selecting a VCCI Capacitor

A bypass capacitor connected to VCCI supports the transient current needed for the primary logic and the total current consumption, which is only a few mA. Therefore, a 50-V MLCC with over 100 nF is recommended for this application. If the bias power supply output is a relatively long distance from the VCCI pin, a tantalum or electrolytic capacitor, with a value over 1 μ F, should be placed in parallel with the MLCC.

9.2.2.6.2 Selecting a VDDA (Bootstrap) Capacitor

A VDDA capacitor, also referred to as a *bootstrap capacitor* in bootstrap power supply configurations, allows for gate drive current transients up to 6 A, and needs to maintain a stable gate drive voltage for the power transistor.

The total charge needed per switching cycle can be estimated with

$$Q_{\text{Total}} = Q_G + \frac{I_{\text{VDD}} @ 100\text{kHz (No Load)}}{f_{\text{SW}}} = 60\text{nC} + \frac{1.5\text{mA}}{100\text{kHz}} = 75\text{nC} \quad (19)$$

where

- Q_G : Gate charge of the power transistor.
- I_{VDD} : The channel self-current consumption with no load at 100kHz.

Therefore, the absolute minimum C_{Boot} requirement is:

$$C_{\text{Boot}} = \frac{Q_{\text{Total}}}{\Delta V_{\text{VDDA}}} = \frac{75\text{nC}}{0.5\text{V}} = 150\text{nF} \quad (20)$$

where

- ΔV_{VDDA} is the voltage ripple at VDDA, which is 0.5 V in this example.

In practice, the value of C_{Boot} is greater than the calculated value. This allows for the capacitance shift caused by the DC bias voltage and for situations where the power stage would otherwise skip pulses due to load transients. Therefore, it is recommended to include a safety-related margin in the C_{Boot} value and place it as close to the VDD and VSS pins as possible. A 50-V 1- μ F capacitor is chosen in this example.

$$C_{\text{Boot}} = 1\mu\text{F} \quad (21)$$

To further lower the AC impedance for a wide frequency range, it is recommended to have bypass capacitor with a low capacitance value, in this example a 100 nF, in parallel with C_{Boot} to optimize the transient performance.

Note

Too large C_{BOOT} is not good. C_{BOOT} may not be charged within the first few cycles and V_{BOOT} could stay below UVLO. As a result, the high-side FET does not follow input signal command. Also during initial C_{BOOT} charging cycles, the bootstrap diode has highest reverse recovery current and losses.

9.2.2.6.3 Select a VDDB Capacitor

Channel B has the same current requirements as Channel A, Therefore, a VDDB capacitor (Shown as C_{VDD} in [Figure 9-1](#)) is needed. In this example with a bootstrap configuration, the VDDB capacitor will also supply current for VDDA through the bootstrap diode. A 50-V, 10- μ F MLCC and a 50-V, 220-nF MLCC are chosen for C_{VDD} . If the bias power supply output is a relatively long distance from the VDDB pin, a tantalum or electrolytic capacitor, with a value over 10 μ F, should be used in parallel with C_{VDD} .

9.2.2.7 Dead Time Setting Guidelines

For power converter topologies utilizing half-bridges, the dead time setting between the top and bottom transistor is important for preventing shoot-through during dynamic switching.

The UCC20520 dead time specification in the electrical table is defined as the time interval from 90% of one channel's falling edge to 10% of the other channel's rising edge (see [Figure 7-4](#)). This definition ensures that the dead time setting is independent of the load condition, and guarantees linearity through manufacture testing. However, this dead time setting may not reflect the dead time in the power converter system, since the dead time setting is dependent on the external gate drive turn-on/off resistor, DC-Link switching voltage/current, as well as the input capacitance of the load transistor.

Here is a suggestion on how to select an appropriate dead time for UCC20520:

$$DT_{\text{Setting}} = DT_{\text{Req}} + T_{F_Sys} + T_{R_Sys} - T_{D(\text{on})} \quad (22)$$

where

- DT_{setting} : UCC20520 dead time setting in ns, $DT_{\text{Setting}} = 10 \times RDT(\text{in k}\Omega)$.
- DT_{Req} : System required dead time between the real V_{GS} signal of the top and bottom switch with enough margin, or ZVS requirement.
- T_{F_Sys} : In-system gate turn-off falling time at worst case of load, voltage/current conditions.
- T_{R_Sys} : In-system gate turn-on rising time at worst case of load, voltage/current conditions.
- $T_{D(\text{on})}$: Turn-on delay time, from 10% of the transistor gate signal to power transistor gate threshold.

In the example, DT_{Setting} is set to 250 ns.

It should be noted that the UCC20520 dead time setting is decided by the DT pin configuration (See [Section 8.4.2](#)), and it cannot automatically fine-tune the dead time based on system conditions, i.e. zero voltage switching conditions. It is recommended to parallel a ceramic capacitor, 2.2nF or above, with R_{DT} to achieve better noise immunity and deadtime matching.

9.2.2.8 Application Circuits with Output Stage Negative Bias

When parasitic inductances are introduced by non-ideal PCB layout and long package leads (e.g. TO-220 and TO-247 type packages), there could be ringing in the gate-source drive voltage of the power transistor during high di/dt and dv/dt switching. If the ringing is over the threshold voltage, there is the risk of unintended turn-on and even shoot-through. Applying a negative bias on the gate drive is a popular way to keep such ringing below the threshold. Below are a few examples of implementing negative gate drive bias.

Figure 9-2 shows the first example with negative bias turn-off on the channel-A driver using a Zener diode on the isolated power supply output stage. The negative bias is set by the Zener diode voltage. If the isolated power supply, V_A , is equal to 25 V, the turn-off voltage will be -5.1 V and turn-on voltage will be 25 V $- 5.1$ V ≈ 20 V. The channel-B driver circuit is the same as channel-A, therefore, this configuration needs two power supplies for a half-bridge configuration, and there will be steady state power consumption from R_Z .

9.2.2.9

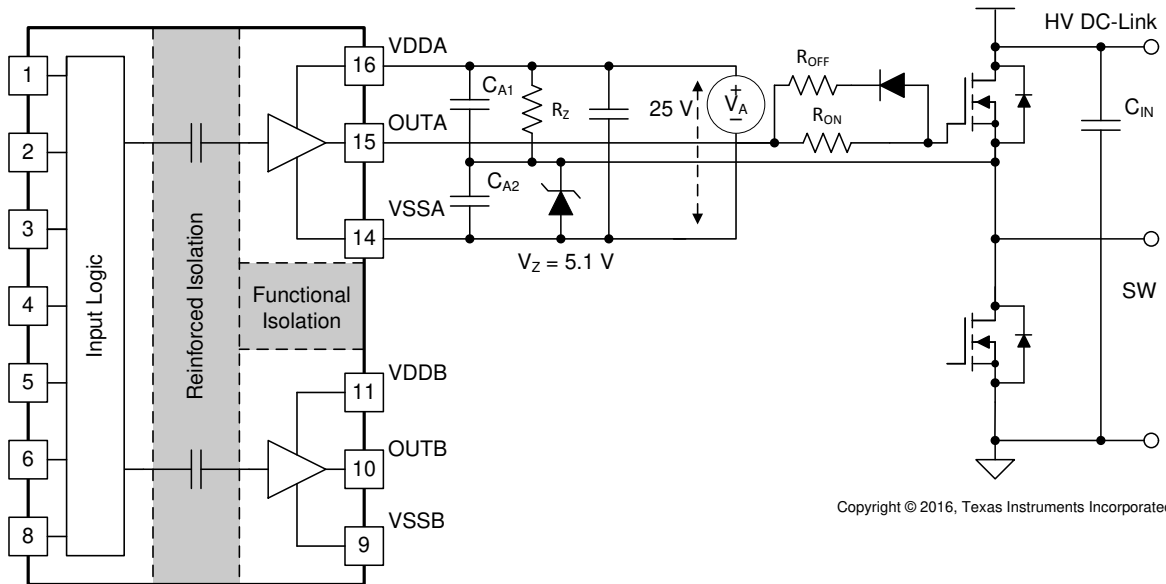

Copyright © 2016, Texas Instruments Incorporated

Figure 9-2. Negative Bias with Zener Diode on Iso-Bias Power Supply Output

Figure 9-3 shows another example which uses two supplies (or single-input-double-output power supply). Power supply V_{A+} determines the positive drive output voltage and V_{A-} determines the negative turn-off voltage. The configuration for channel B is the same as channel A. This solution requires more power supplies than the first example, however, it provides more flexibility when setting the positive and negative rail voltages.

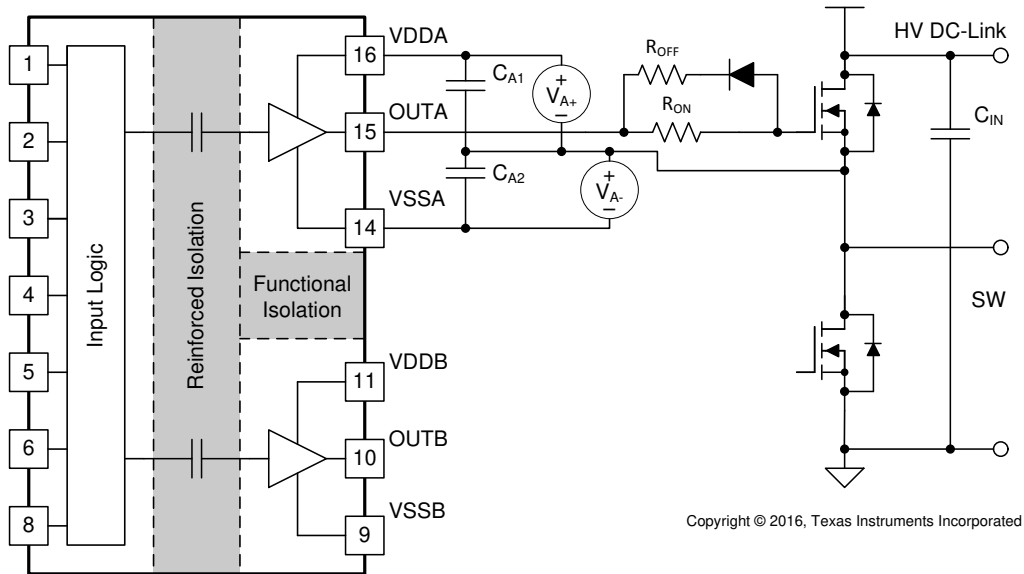

Copyright © 2016, Texas Instruments Incorporated

Figure 9-3. Negative Bias with Two Iso-Bias Power Supplies

The last example, shown in [Figure 9-4](#), is a single power supply configuration and generates negative bias through a Zener diode in the gate drive loop. The benefit of this solution is that it only uses one power supply and the bootstrap power supply can be used for the high side drive. This design requires the least cost and design effort among the three solutions. However, this solution has limitations:

1. The negative gate drive bias is not only determined by the Zener diode, but also by the duty cycle, which means the negative bias voltage will change when the duty cycle changes. Therefore, converters with a fixed duty cycle (~50%) such as variable frequency resonant converters or phase shift converters which favor this solution.
2. The high side VDDA-VSSA must maintain enough voltage to stay in the recommended power supply range, which means the low side switch must turn-on or have free-wheeling current on the body (or anti-parallel) diode for a certain period during each switching cycle to refresh the bootstrap capacitor. Therefore, a 100% duty cycle for the high side is not possible unless there is a dedicated power supply for the high side, like in the other two example circuits.

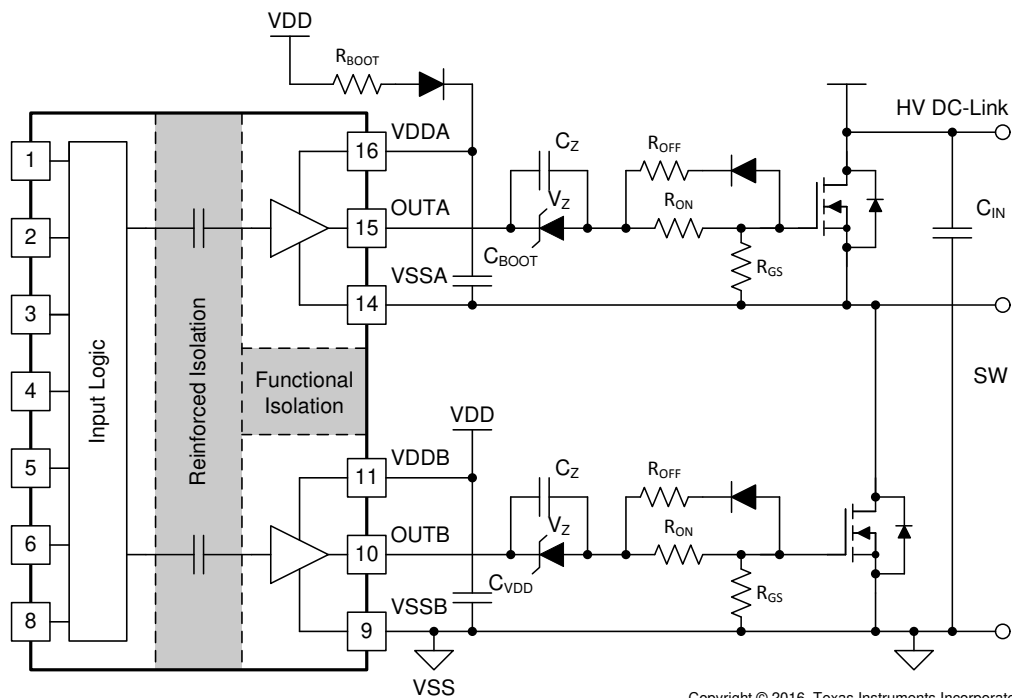

Figure 9-4. Negative Bias with Single Power Supply and Zener Diode in Gate Drive Path

9.2.3 Application Curves

Figure 9-5 and Figure 9-6 shows the bench test waveforms for the design example shown in Figure 9-1 under these conditions: VCC = 5 V, VDD = 20 V, $f_{SW} = 100$ kHz, $V_{DC-Link} = 0$ V.

Channel 1 (Blue): UCC20520 PWM pin signal.

Channel 2 (Red): Gate-source signal on the high side power transistor.

Channel 3 (Green): Gate-source signal on the low side power transistor.

In Figure 9-5, PWM is sent with 50% duty-cycle signals. The gate drive signals on the power transistor have a 250-ns dead time, shown in the measurement section of Figure 9-5.

Figure 9-6 shows a zoomed-in version of the waveform of Figure 9-5, with measurements for propagation delay and rising/falling time. Cursors are also used to measure dead time. Importantly, the output waveform is measured between the power transistors' gate and source pins, and is not measured directly from the driver OUTA and OUTB pins. Due to the split on and off resistors (R_{ON}, R_{OFF}) and different sink and source currents, different rising (16 ns) and falling time (9 ns) are observed in Figure 9-6.

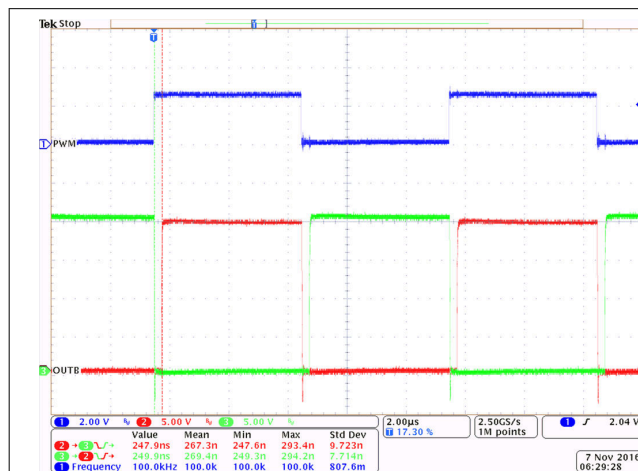

Figure 9-5. Bench Test Waveform for PWM and OUTA/B

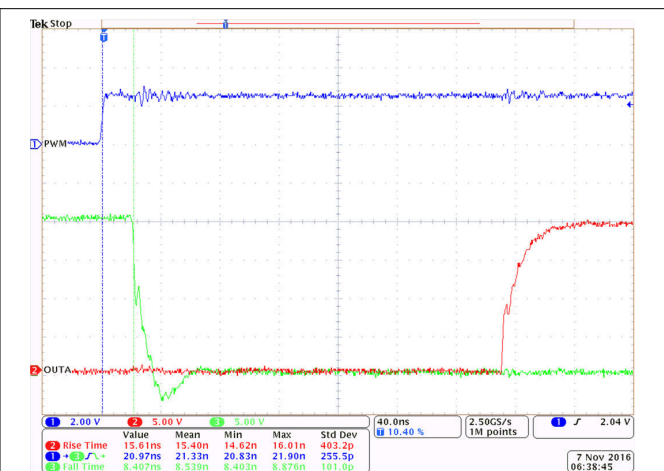

Figure 9-6. Zoomed-In bench-test waveform

Power Supply Recommendations

The recommended input supply voltage (VCCI) for UCC20520 is between 3-V and 18-V. The recommended output bias supply voltage (VDDA/VDDDB) range is between 9.2-V to 25-V. The lower end of this bias supply range is governed by the internal under voltage lockout (UVLO) protection feature of each device. One mustn't let VDD or VCCI fall below their respective UVLO thresholds (For more information on UVLO see [Section 8.3.1](#)). The upper end of the VDDA/VDDDB range depends on the maximum gate voltage of the power device being driven by UCC20520.

A local bypass capacitor should be placed between the VDD and VSS pins. This capacitor should be positioned as close to the device as possible. A low ESR, ceramic surface mount capacitor is recommended. It is further suggested that one place two such capacitors: one with a value of between 220 nF and 10 μ F for device biasing, and an additional 100-nF capacitor in parallel for high frequency filtering.

Similarly, a bypass capacitor should also be placed between the VCCI and GND pins. Given the small amount of current drawn by the logic circuitry within the input side of UCC20520, this bypass capacitor has a minimum recommended value of 100 nF.

10 Layout

10.1 Layout Guidelines

To achieve optimum performance for the UCC20520, pay close attention to PCB layout in order.

Component Placement:

- Low-ESR and low-ESL capacitors must be connected close to the device between the VCCI and GND pins and between the VDD and VSS pins to support high peak currents when turning on the external power transistor.
- To avoid large negative transients on the switch node VSSA (HS) pin, the parasitic inductances between the source of the top transistor and the source of the bottom transistor must be minimized.
- It is recommended to place the dead time setting resistor, R_{DT} , and its bypassing capacitor close to DT pin of UCC20520.

Grounding Considerations:

- It is essential to confine the high peak currents that charge and discharge the transistor gates to a minimal physical area. This will decrease the loop inductance and minimize noise on the gate terminals of the transistors. The gate driver must be placed as close as possible to the transistors.
- Pay attention to high current path that includes the bootstrap capacitor, bootstrap diode, local VSSB-referenced bypass capacitor, and the low-side transistor body/anti-parallel diode. The bootstrap capacitor is recharged on a cycle-by-cycle basis through the bootstrap diode by the VDD bypass capacitor. This recharging occurs in a short time interval and involves a high peak current. Minimizing this loop length and area on the circuit board is important for ensuring reliable operation.

High-Voltage Considerations:

- To ensure isolation performance between the primary and secondary side, one should avoid placing any PCB traces or copper below the driver device. A PCB cutout is recommended in order to prevent contamination that may compromise the UCC20520's isolation performance.
- For half-bridge, or high-side/low-side configurations, where the channel A and channel B drivers could operate with a DC-link voltage up to 1500 V_{DC}, one should try to increase the creepage distance of the PCB layout between the high and low-side PCB traces.

Thermal Considerations:

- A large amount of power may be dissipated by the UCC20520 if the driving voltage is high, the load is heavy, or the switching frequency is high (Refer to [Section 9.2.2.4](#) for more details). Proper PCB layout can help dissipate heat from the device to the PCB and minimize junction to board thermal impedance (θ_{JB}).
- Increasing the PCB copper connecting to VDDA, VDDB, VSSA and VSSB pins is recommended (See [Figure 10-2](#) and [Figure 10-3](#)). However, high voltage PCB considerations mentioned above must be maintained.
- If there are multiple layers in the system, it is also recommended to connect the VDDA, VDDB, VSSA and VSSB pins to internal ground or power planes through multiple vias of adequate size. However, keep in mind that there shouldn't be any traces/coppers from different high voltage planes overlapping.

10.2 Layout Example

Figure 10-1 shows a 2-layer PCB layout example with the signals and key components labeled.

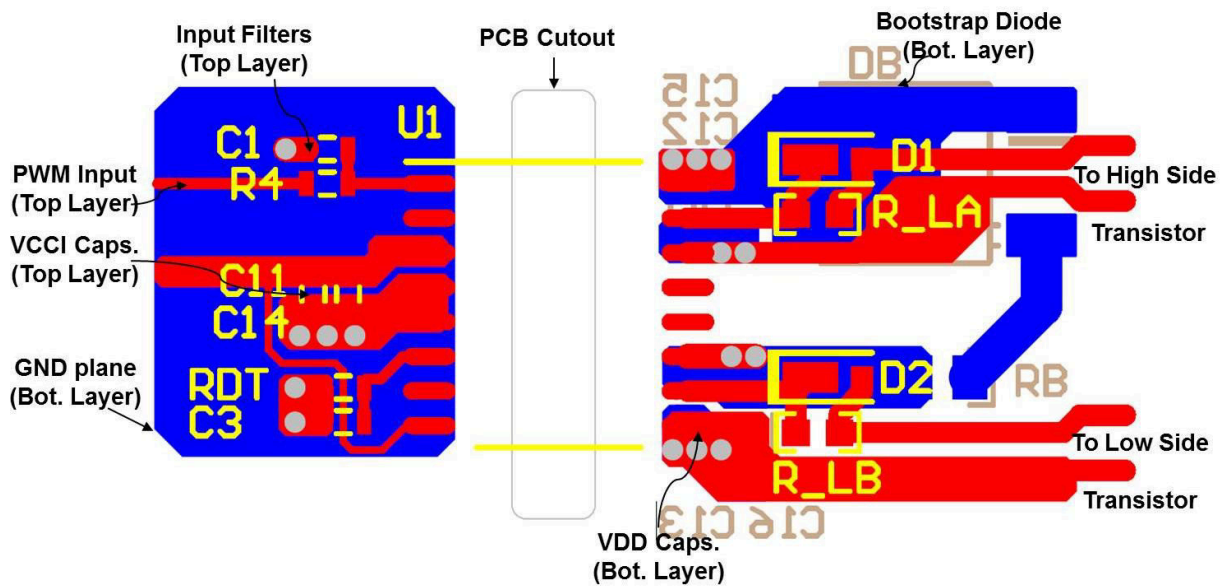

Figure 10-1. Layout Example

Figure 10-2 and Figure 10-3 shows top and bottom layer traces and copper.

Note

There are no PCB traces or copper between the primary and secondary side, which ensures isolation performance.

PCB traces between the high-side and low-side gate drivers in the output stage are increased to maximize the creepage distance for high-voltage operation, which will also minimize cross-talk between the switching node VSSA (SW), where high dv/dt may exist, and the low-side gate drive due to the parasitic capacitance coupling.

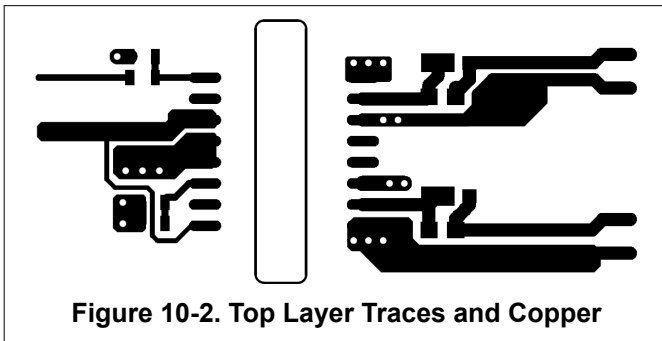

Figure 10-2. Top Layer Traces and Copper

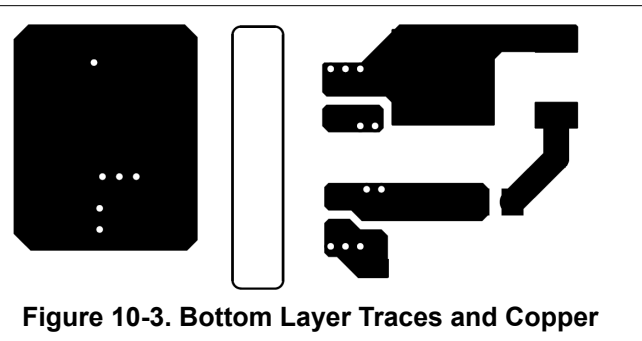

Figure 10-3. Bottom Layer Traces and Copper

Figure 10-4 and Figure 10-5 are 3D layout pictures with top view and bottom views.

Note

The location of the PCB cutout between the primary side and secondary sides, which ensures isolation performance.

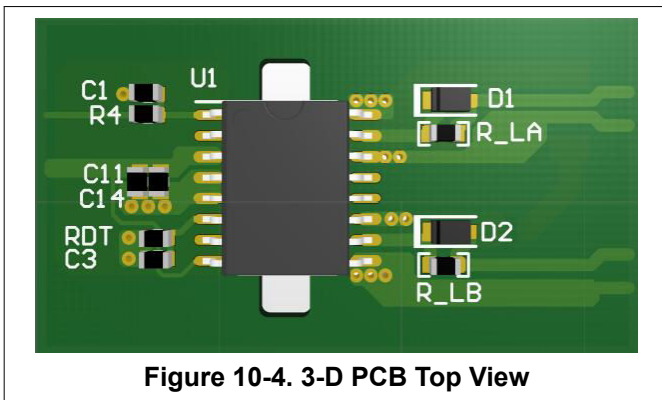

Figure 10-4. 3-D PCB Top View

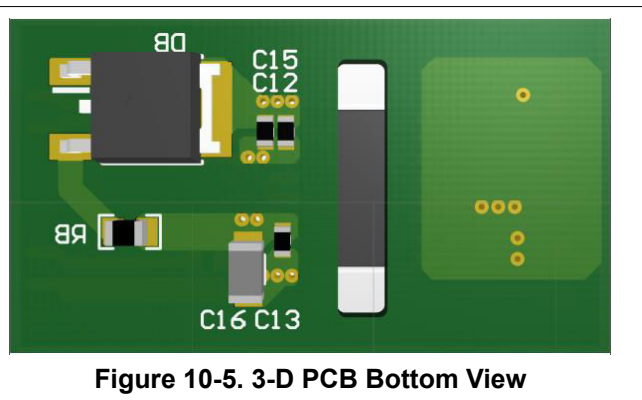

Figure 10-5. 3-D PCB Bottom View

11 Device and Documentation Support

11.1 Documentation Support

11.1.1 Related Documentation

For related documentation see the following:

- [Isolation Glossary](#)

11.2 Receiving Notification of Documentation Updates

To receive notification of documentation updates, navigate to the device product folder on [ti.com](#). Click on *Subscribe to updates* to register and receive a weekly digest of any product information that has changed. For change details, review the revision history included in any revised document.

11.3 Support Resources

TI E2E™ [support forums](#) are an engineer's go-to source for fast, verified answers and design help — straight from the experts. Search existing answers or ask your own question to get the quick design help you need.

Linked content is provided "AS IS" by the respective contributors. They do not constitute TI specifications and do not necessarily reflect TI's views; see TI's [Terms of Use](#).

11.3.1 Certifications

UL Online Certifications Directory, "[FPPT2.E181974 Nonoptical Isolating Devices - Component](#)" Certificate Number: 20160516-E181974, (SLUQ001)

VDE Online Certifications Directory, "[Certificate of Conformity with Factory Surveillance](#)" Certificate Number: 40040142

CQC Online Certifications Directory, "[GB4943.1-2011, Digital Isolator Certificate](#)" Certificate Number: CQC16001155011

11.4 Trademarks

TI E2E™ is a trademark of Texas Instruments.

All trademarks are the property of their respective owners.

11.5 Electrostatic Discharge Caution



This integrated circuit can be damaged by ESD. Texas Instruments recommends that all integrated circuits be handled with appropriate precautions. Failure to observe proper handling and installation procedures can cause damage.

ESD damage can range from subtle performance degradation to complete device failure. Precision integrated circuits may be more susceptible to damage because very small parametric changes could cause the device not to meet its published specifications.

11.6 Glossary

[TI Glossary](#) This glossary lists and explains terms, acronyms, and definitions.

Mechanical, Packaging, and Orderable Information

The following pages include mechanical, packaging, and orderable information. This information is the most current data available for the designated devices. This data is subject to change without notice and revision of this document. For browser-based versions of this data sheet, refer to the left-hand navigation.

PACKAGING INFORMATION

Orderable Device	Status (1)	Package Type	Package Drawing	Pins	Package Qty	Eco Plan (2)	Lead finish/ Ball material (6)	MSL Peak Temp (3)	Op Temp (°C)	Device Marking (4/5)	Samples
UCC20520DW	LIFEBUY	SOIC	DW	16	40	RoHS & Green	NIPDAU	Level-2-260C-1 YEAR	-40 to 125	UCC20520	
UCC20520DWR	ACTIVE	SOIC	DW	16	2000	RoHS & Green	NIPDAU	Level-2-260C-1 YEAR	-40 to 125	UCC20520	Samples

(1) The marketing status values are defined as follows:

ACTIVE: Product device recommended for new designs.

LIFEBUY: TI has announced that the device will be discontinued, and a lifetime-buy period is in effect.

NRND: Not recommended for new designs. Device is in production to support existing customers, but TI does not recommend using this part in a new design.

PREVIEW: Device has been announced but is not in production. Samples may or may not be available.

OBSOLETE: TI has discontinued the production of the device.

(2) **RoHS:** TI defines "RoHS" to mean semiconductor products that are compliant with the current EU RoHS requirements for all 10 RoHS substances, including the requirement that RoHS substance do not exceed 0.1% by weight in homogeneous materials. Where designed to be soldered at high temperatures, "RoHS" products are suitable for use in specified lead-free processes. TI may reference these types of products as "Pb-Free".

RoHS Exempt: TI defines "RoHS Exempt" to mean products that contain lead but are compliant with EU RoHS pursuant to a specific EU RoHS exemption.

Green: TI defines "Green" to mean the content of Chlorine (Cl) and Bromine (Br) based flame retardants meet JS709B low halogen requirements of <=1000ppm threshold. Antimony trioxide based flame retardants must also meet the <=1000ppm threshold requirement.

(3) MSL, Peak Temp. - The Moisture Sensitivity Level rating according to the JEDEC industry standard classifications, and peak solder temperature.

(4) There may be additional marking, which relates to the logo, the lot trace code information, or the environmental category on the device.

(5) Multiple Device Markings will be inside parentheses. Only one Device Marking contained in parentheses and separated by a "~" will appear on a device. If a line is indented then it is a continuation of the previous line and the two combined represent the entire Device Marking for that device.

(6) Lead finish/Ball material - Orderable Devices may have multiple material finish options. Finish options are separated by a vertical ruled line. Lead finish/Ball material values may wrap to two lines if the finish value exceeds the maximum column width.

Important Information and Disclaimer:The information provided on this page represents TI's knowledge and belief as of the date that it is provided. TI bases its knowledge and belief on information provided by third parties, and makes no representation or warranty as to the accuracy of such information. Efforts are underway to better integrate information from third parties. TI has taken and continues to take reasonable steps to provide representative and accurate information but may not have conducted destructive testing or chemical analysis on incoming materials and chemicals. TI and TI suppliers consider certain information to be proprietary, and thus CAS numbers and other limited information may not be available for release.

In no event shall TI's liability arising out of such information exceed the total purchase price of the TI part(s) at issue in this document sold by TI to Customer on an annual basis.

GENERIC PACKAGE VIEW

DW 16

SOIC - 2.65 mm max height

7.5 x 10.3, 1.27 mm pitch

SMALL OUTLINE INTEGRATED CIRCUIT

This image is a representation of the package family, actual package may vary.
Refer to the product data sheet for package details.

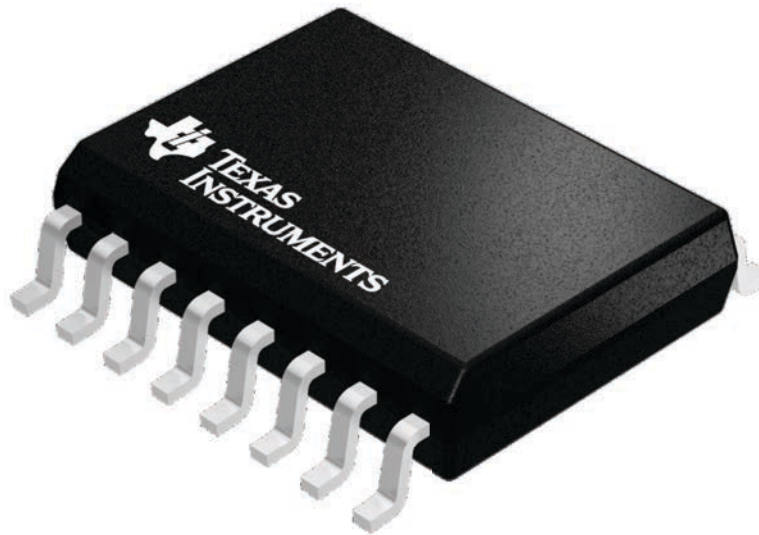

4224780/A



DW0016B

PACKAGE OUTLINE SOIC - 2.65 mm max height

SOIC

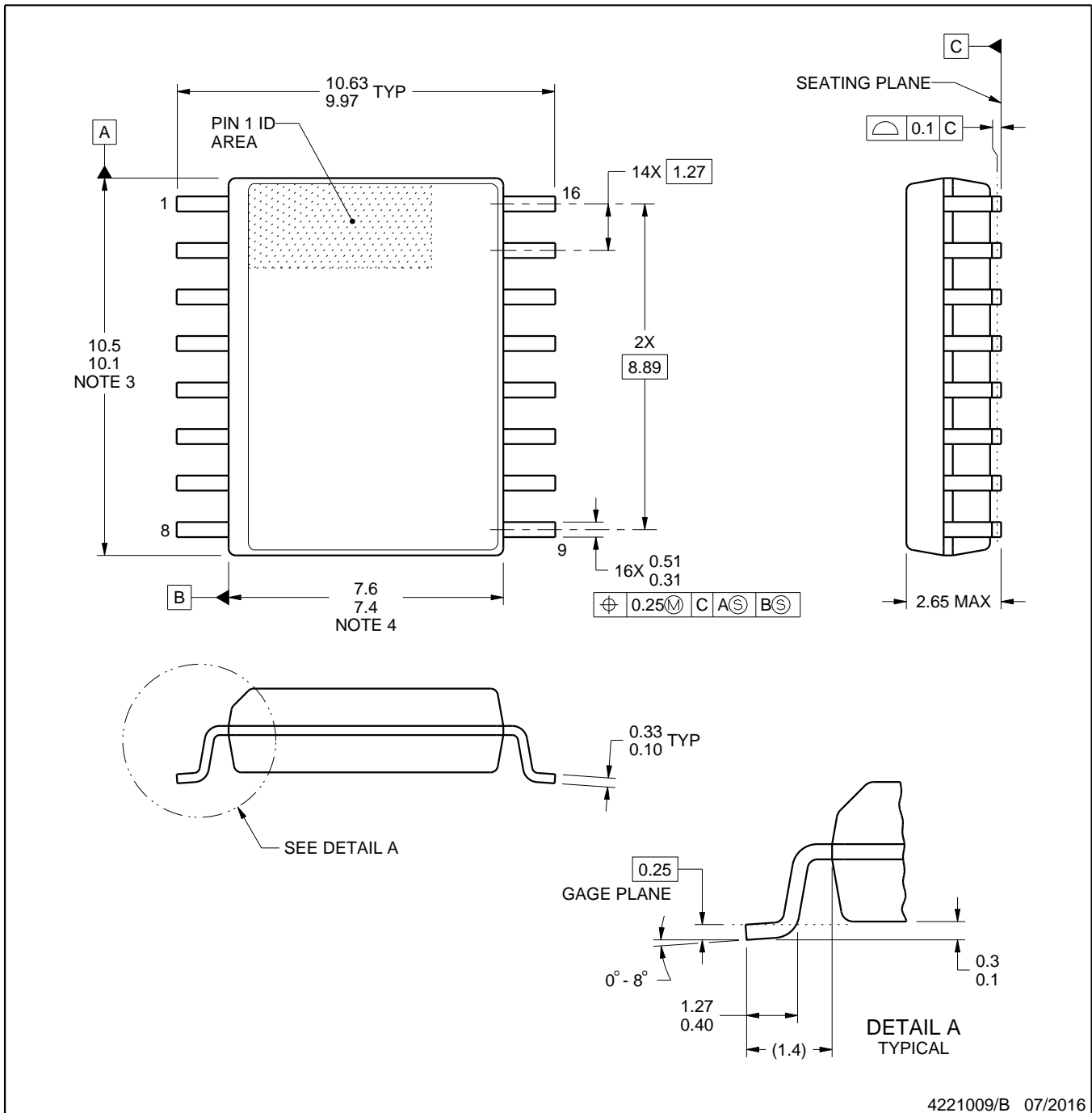

4221009/B 07/2016

NOTES:

1. All linear dimensions are in millimeters. Dimensions in parenthesis are for reference only. Dimensioning and tolerancing per ASME Y14.5M.
2. This drawing is subject to change without notice.
3. This dimension does not include mold flash, protrusions, or gate burrs. Mold flash, protrusions, or gate burrs shall not exceed 0.15 mm, per side.
4. This dimension does not include interlead flash. Interlead flash shall not exceed 0.25 mm, per side.
5. Reference JEDEC registration MS-013.

EXAMPLE BOARD LAYOUT

DW0016B

SOIC - 2.65 mm max height

SOIC

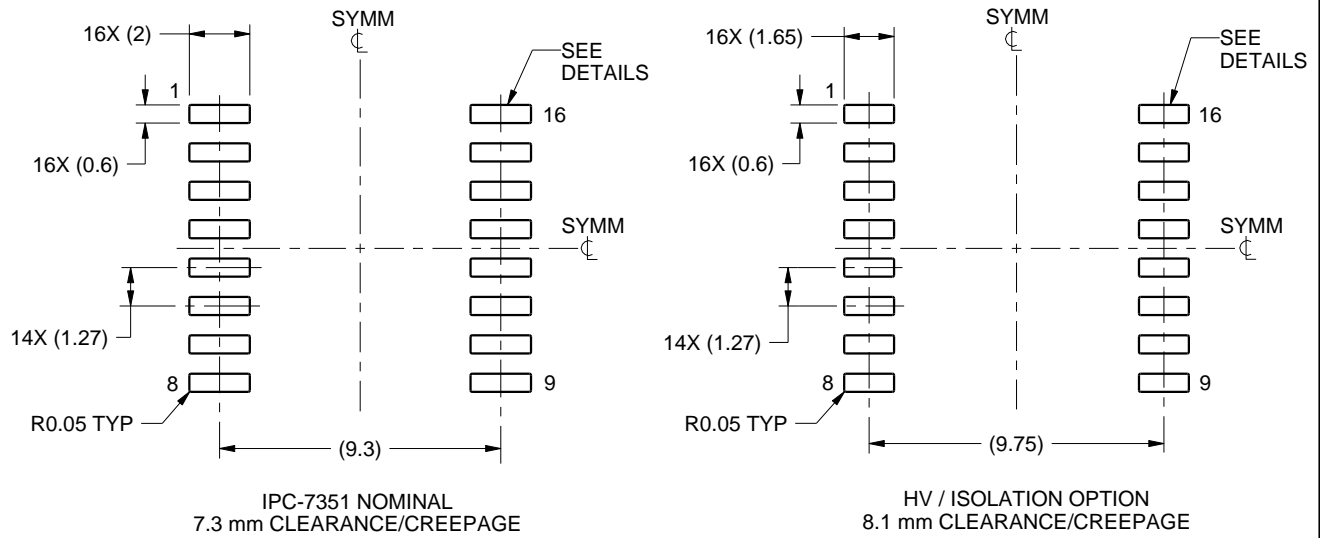

LAND PATTERN EXAMPLE
SCALE:4X

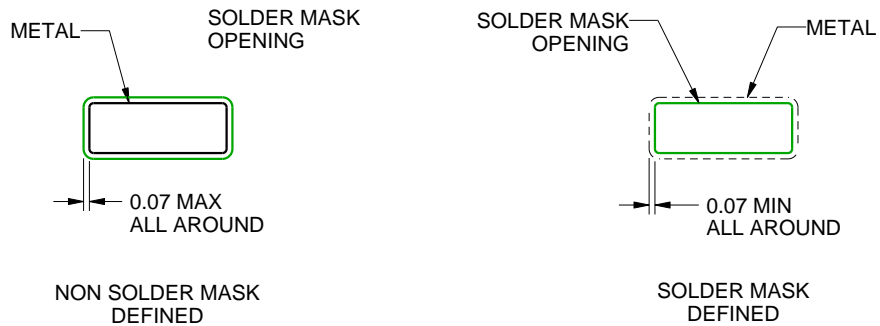

SOLDER MASK DETAILS

4221009/B 07/2016

NOTES: (continued)

- 6. Publication IPC-7351 may have alternate designs.
- 7. Solder mask tolerances between and around signal pads can vary based on board fabrication site.

EXAMPLE STENCIL DESIGN

DW0016B

SOIC - 2.65 mm max height

SOIC

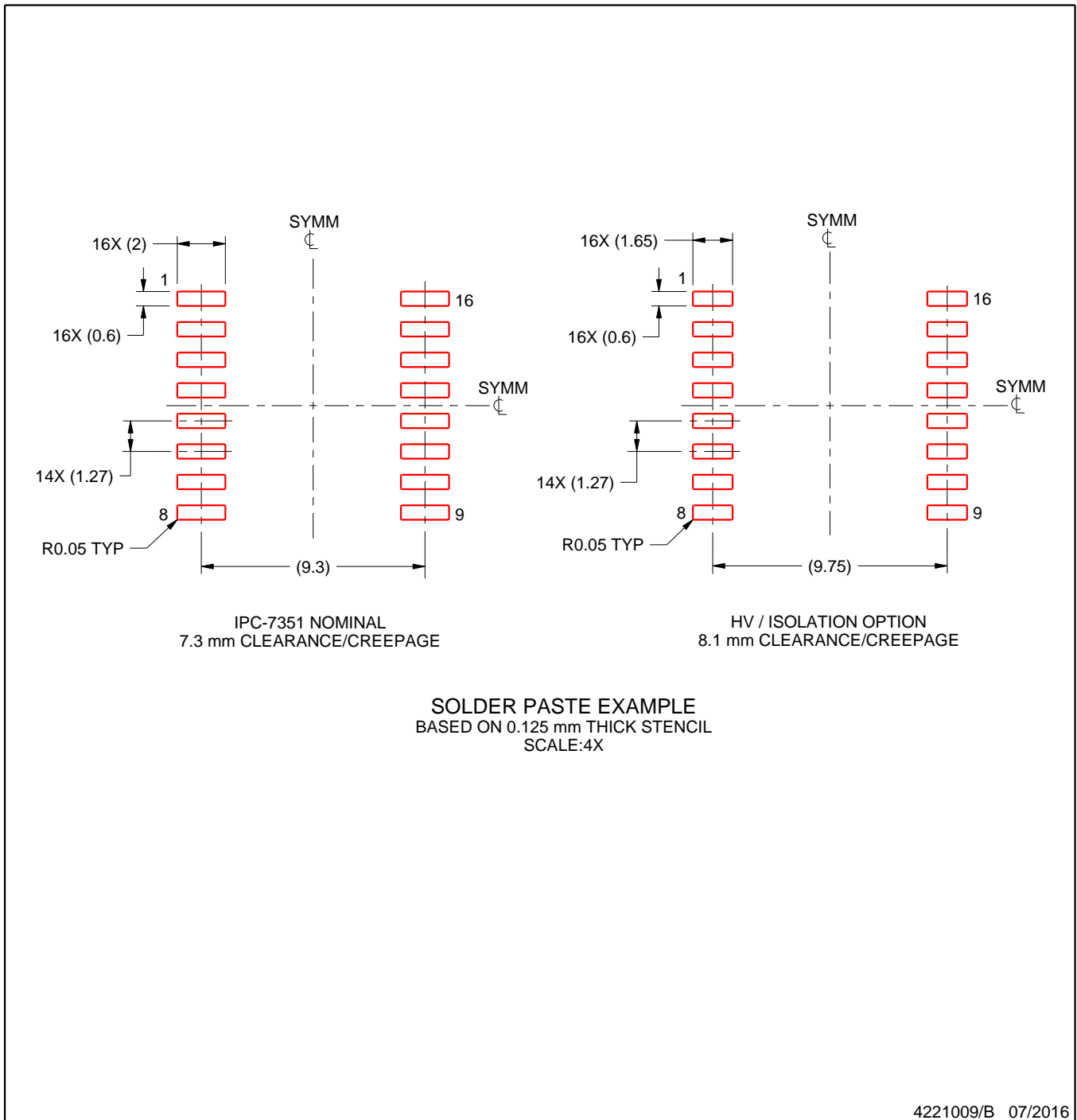

NOTES: (continued)

8. Laser cutting apertures with trapezoidal walls and rounded corners may offer better paste release. IPC-7525 may have alternate design recommendations.
9. Board assembly site may have different recommendations for stencil design.

IMPORTANT NOTICE AND DISCLAIMER

TI PROVIDES TECHNICAL AND RELIABILITY DATA (INCLUDING DATA SHEETS), DESIGN RESOURCES (INCLUDING REFERENCE DESIGNS), APPLICATION OR OTHER DESIGN ADVICE, WEB TOOLS, SAFETY INFORMATION, AND OTHER RESOURCES "AS IS" AND WITH ALL FAULTS, AND DISCLAIMS ALL WARRANTIES, EXPRESS AND IMPLIED, INCLUDING WITHOUT LIMITATION ANY IMPLIED WARRANTIES OF MERCHANTABILITY, FITNESS FOR A PARTICULAR PURPOSE OR NON-INFRINGEMENT OF THIRD PARTY INTELLECTUAL PROPERTY RIGHTS.

These resources are intended for skilled developers designing with TI products. You are solely responsible for (1) selecting the appropriate TI products for your application, (2) designing, validating and testing your application, and (3) ensuring your application meets applicable standards, and any other safety, security, regulatory or other requirements.

These resources are subject to change without notice. TI grants you permission to use these resources only for development of an application that uses the TI products described in the resource. Other reproduction and display of these resources is prohibited. No license is granted to any other TI intellectual property right or to any third party intellectual property right. TI disclaims responsibility for, and you will fully indemnify TI and its representatives against, any claims, damages, costs, losses, and liabilities arising out of your use of these resources.

TI's products are provided subject to [TI's Terms of Sale](#) or other applicable terms available either on [ti.com](https://www.ti.com) or provided in conjunction with such TI products. TI's provision of these resources does not expand or otherwise alter TI's applicable warranties or warranty disclaimers for TI products.

TI objects to and rejects any additional or different terms you may have proposed.

Mailing Address: Texas Instruments, Post Office Box 655303, Dallas, Texas 75265
Copyright © 2024, Texas Instruments Incorporated

Looking for pricing, stock, or lifecycle information?

Click below to explore more details on WIN SOURCE:

 [View AC0805JR-0712KL on WIN SOURCE](#)

 [Yageo Information](#)

Optimize Your Supply Chain with WIN SOURCE Solutions

-  Global Sourcing Solution
-  Obsolete Management
-  Cost Control Management
-  Shortage Management
-  Alternative Solution
-  Excess Inventory Management