



THE DATASHEET OF JR200



TRIMMERS ***and non-magnetic components***



PRECISION DEVICES
knowles



COMPEX • DLI • JOHANSON MFG
NOVACAP • SYFER • VOLTRONICS

Introduction to Knowles Precision Devices

Knowles Precision Devices is a premier global source for Capacitors, RF Filters, EMI Filters, Resonators, non-magnetic components and advanced dielectric materials.

An umbrella for the brands of Compex, DLI, Johanson MFG, Novacap, Syfer and Voltronics, Knowles Precision Devices serves a variety of markets including: military, aerospace/avionics, medical equipment, implantable devices, EMI and connector filtering, oil exploration, instrumentation, industrial electronics, automotive, telecoms and data networks.



						
Capacitors: AEC-Q200					•	
Capacitors: Broadband Blocks		•				
Capacitors: Cap Assemblies				•		
Capacitors: Detonation Pulse				•		
Capacitors: High Power		•			•	•
Capacitors: High Q		•			•	•
Capacitors: High Reliability		•		•	•	
Capacitors: High Temperature				•	•	
Capacitors: High Voltage				•	•	
Capacitors: MLC - Leaded		•		•	•	
Capacitors: MLC - SMD				•	•	
Capacitors: Non-Magnetic		•		•	•	•
Capacitors: Non-Magnetic Trimmers			•			•
Capacitors: Planars and Discoidals					•	
Capacitors: Safety Certified				•	•	
Capacitors: Single Layer	•	•				
Capacitors: Trimmers			•			•
Dielectric Substrates		•				
EMI Filters					•	
Non-Magnetic Hardware						•
Non-Magnetic Inductors			•			
Microwave Couplers		•				
Microwave Filters		•				
Microwave Power Dividers		•				
Microwave Resonators		•				
RF: Gain Equalizers		•				
RF: Bias Filter Networks		•				
RF: Self Bias Networks		•				
Thin Film: Build To Print		•				
Heatsink/Standoff	•					
Mounting Shorts	•					



Contents

Half Turn Ceramic SM Chip Trimmers	Half Turn Ceramic Chip Trimmers - Product Guide.....	Johanson-Voltronics	2
	JZ & JZ_HV Series	Voltronics	3
	JR & JR_HV Series.....	Voltronics	4
	Thin-Trim® Trimmers - 9401 & 9701 Series.....	Johanson	5-8
	Cera-Trim® Trimmers - 2320 & 2322 Series.....	Johanson	9
	Seal-Trim® Trimmers - 9610, 9810, 9620 & 9820 Series.....	Johanson	10-11
<hr/>			
Precision Trimmers Air PTFE Non-Magnetic Sapphire	Air & PTFE Trimmers - Product Guide.....	Voltronics	12
	Air Trimmers - Product Guide	Johanson	13
	Air/PTFE Trimmers - Lead Styles.....	Voltronics	14
	Standard Air Trimmers - A Series.....	Voltronics	15
	Air Trimmers	Johanson	16-18
	Air Trimmers - K Series	Voltronics	19
	Air Dielectric Variable Trimmers	Johanson	20
	Non-Magnetic Air Trimmers.....	Johanson	21
	PTFE Trimmers - A1 Series.....	Voltronics	22
	Miniature Trimmers - A4 Series.....	Voltronics	23
	High Voltage PTFE Trimmers - A_HV Series	Voltronics	24
	High Voltage PTFE Trimmers - K_HV Series	Voltronics	25
	Very High Voltage PTFE Trimmers.....	Voltronics	26
	Non-Magnetic PTFE Trimmers - NMNT Series.....	Voltronics	27
	High Voltage Trimmers.....	Johanson	28
	Giga-Trim® Trimmers 9402 & 9401.....	Johanson	29-32
	Non-Magnetic Sapphire Trimmer - V9000	Voltronics	33
	<hr/>		
Precision Trimmers Glass Quartz	Glass & Quartz Trimmers - Specifications	Voltronics	34
	Smallest Sealed Glass Trimmers - S Series.....	Voltronics	35
	Extended Range Glass Trimmers - H Series	Voltronics	36
	Vertical P.C. Mount Glass Trimmers - TF Series	Voltronics	37
	Panel Mount Glass & Quartz Trimmers - TM & QM Series	Voltronics	38-39
	Horizontal Mount Glass & Quartz Trimmers - TP & QP Series	Voltronics	40-41
	Differential Glass Trimmers	Voltronics	42
	Split Stator Glass Trimmers	Voltronics	42
	Tuning Tools	Voltronics	43
	<hr/>		
Precision Microwave Tuners	Microwave Tuning Elements	Johanson	44
	Dielectric Tuning Elements	Johanson	45
	Metallic Tuning Elements.....	Johanson	46
	Tuning Screw Torque Bushings.....	Johanson	47
	Tuning Rotors	Johanson	48
	Dyna-Trim™ - Resonator Tuners	Johanson	49
<hr/>			
Non-Magnetic Capacitors	Multilayer Capacitors - High Q, C0G/NP0 & X7R.....	Syfer-Voltronics	50-51
	Non-Magnetic Capacitors, High Power RF - High Q.....	Syfer-Voltronics	52-53
<hr/>			
Non-Magnetic Variable Inductors	Non-Magnetic Variable Inductors	Johanson	54
<hr/>			
Non-Magnetic Fasteners and Hardware	Screws, Nuts, Washers and Custom Parts.....	Voltronics	55





Half Turn Ceramic SM Chip Trimmers - Product Guide

Voltronics Product Line	Actual Size Length x Width x Height	Part Number	Cap. Range Min. - Max. pF	Temperature Coefficient	SRF GHz	Mounting	Page
JZ & JZ_HV*	0.177 x 0.126 x 0.059 in 4.5 x 3.2 x 1.5 mm	JZ030	1.5 - 3.0	0±200	2.1	Surface	3
		JZ060	2.0 - 6.0	0±300	1.5		
		JZ080	3.0 - 8.0	-750±500	1.25		
		JZ100	2.0 - 10.0	0±300	1.16		
		JZ150	3.0 - 15.0	0±500	0.92		
		JZ200	4.5 - 20.0	0±500	0.81		
		JZ300	5.5 - 30.0	-1500±1000	0.7		
		JZ400	8.0 - 40.0	-1500±1000	0.6		
JZ500	8.0 - 50.0	-1500±1000	0.53				

* Note: We now offer the series in a HIGH VOLTAGE VERSION. The JZ_HV series specifications are identical to the specifications listed above with this important exception: DC Working Voltage 350DC, Withstanding Voltage 750.



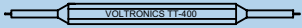

JR & JR_HV*	0.138 x 0.122 x 0.045 in 3.5 x 3.1 x 1.15 mm	JR030	1.5 - 3.0	0±200	2.9	Surface	4
		JR060	2.0 - 6.0	0±300	2.05		
		JR080	3.0 - 8.0	-750±500	1.8		
		JR100	2.0 - 10.0	0±300	1.6		
		JR150	3.0 - 15.0	0±500	1.3		
		JR200	4.5 - 20.0	0±500	1.15		
		JR300	5.5 - 30.0	-1500±1000	0.92		
		JR400	8.0 - 40.0	-1500±1000	0.84		
		JR500	8.0 - 50.0	-1500±1000	-		

Voltronics Tuning Tools

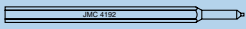

Trimmer Series	Dia.	Voltronics Part Number	
JZ & JZ_HV JR & JR_HV	0.45	TT-400 	TT-900 

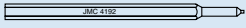
Johanson Product Line	Housing Size	Capacitance	Tuning Resolution	Min. Q @ 100 MHz	Colour Codes
Thin-Trim®	0.125" (3.18mm)	0.25 to 4pF	90°	>1000	Red / Black / Blue / Brown
Cera-Trim®	0.180" x 0.167" (4.57 x 4.24mm)	0.6 to 25pF	180°	300 to 3000	Red / Black / Blue / Green / Amber
Seal-Trim®	0.270" (6.86mm)	1 to 50pF	180°	>200 to >1000	-

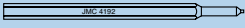
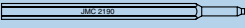
Johanson Tuning Tools

Trimmer Series	Johanson Part Number		
Thin-Trim®	4192 	4193 	
Cera-Trim®	4192 		
Seal-Trim®	4193 	4192 	2190 

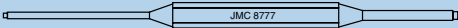
Johanson Tuning Tools

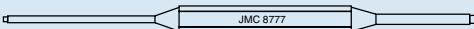
Trimmer Series	Dia.	Johanson Part Number	
5200 5300 5400 5500 5600 5700	.130	8777 	
		8764 	
5800	.078	8777 	



Dimensions - Drawing tolerances where not specified $\pm 0.008"/0.2\text{mm}$

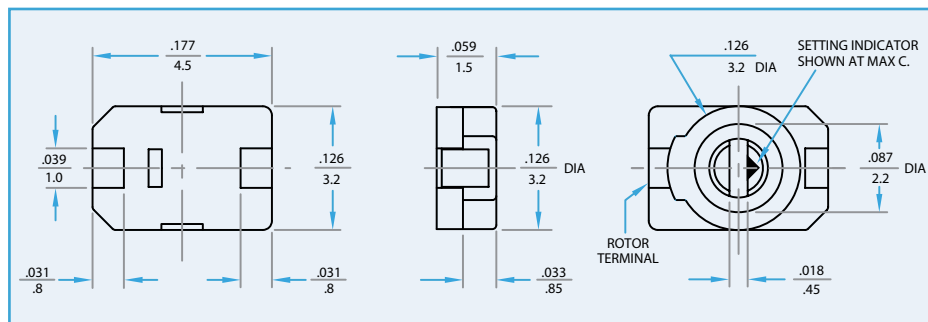

General specifications

Part No. JZ Series	JZ030	JZ060	JZ080	JZ100	JZ150	JZ200	JZ300	JZ400	JZ500
DC Working Voltage	125	125	125	125	125	125	125	125	125
DC Withstanding Voltage	250	250	250	250	250	250	250	250	250

Part No. JZ_HV Series	JZ030HV	JZ060HV	JZ080HV	JZ100HV	JZ150HV	JZ200HV	JZ300HV	JZ400HV
DC Working Voltage	350	350	350	350	350	350	350	350
DC Withstanding Voltage	700	700	700	700	700	700	700	700

Capacitance (pF)	Minimum Maximum	1.5 3.0	2.0 6.0	3.0 8.0	2.0 10.0	3.0 15.0	4.5 20.0	5.5 30.0	8.0 40.0	8.0 50.0
Marking Color*		Black	Blue	Violet	White	Pink	Red	Orange	Yellow	Green
Temperature Coefficient (ppm/°C)		0 ± 200	0 ± 300	-750 ± 500	0 ± 300	0 ± 500	0 ± 500	-1500 ± 1000	-1500 ± 1000	-1500 ± 1000
Approximate Self Resonant Frequency at Maximum Rated Capacitance	JZ & JZ_HV Series	2.1GHz	1.5GHz	1.25GHz	1.16GHz	0.92GHz	0.81GHz	0.70GHz	0.60GHz	0.53GHz
Insulation Resistance		10 ⁴ MΩ								
Operating Temperature		-40°C to +85°C (Tunable temp range -25°C to +85°C)								
Torque		0.14 to 1.0 in-oz								
Packaging		All parts furnished on 12mm tape and reel. 1,000 pcs. per reel.								

* HV parts are indicated by a second, green dot.

Solder Pad Layout

Recommended thickness of solder paste 0.15mm

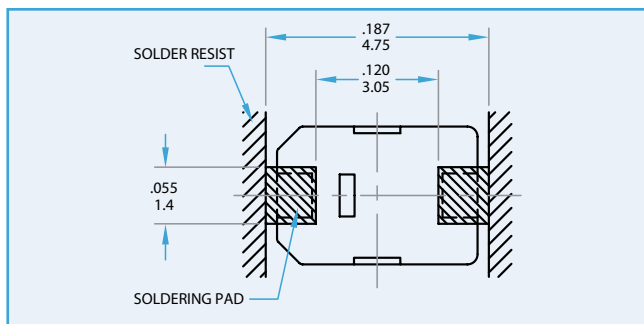

Recommended Reflow Solder Temperature Profile

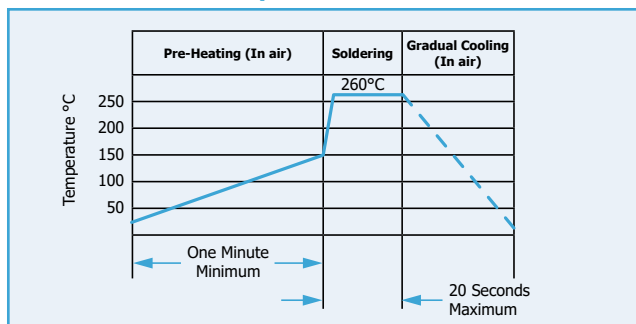

Recommended Tuning Tools

Ceramic Tipped: TT-400

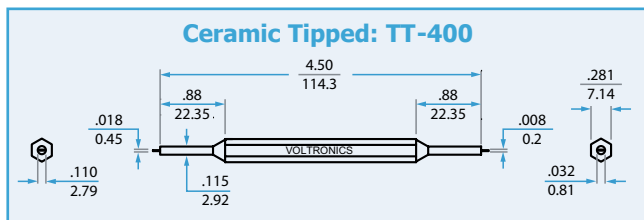

Ceramic Tipped: TT-900

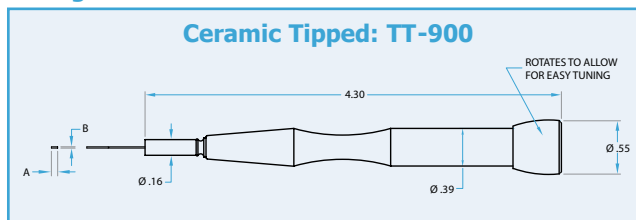

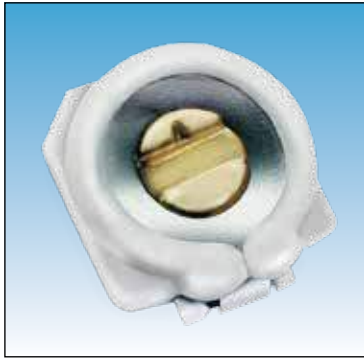

Dimensions - Drawing tolerances where not specified $\pm 0.008"/0.2\text{mm}$

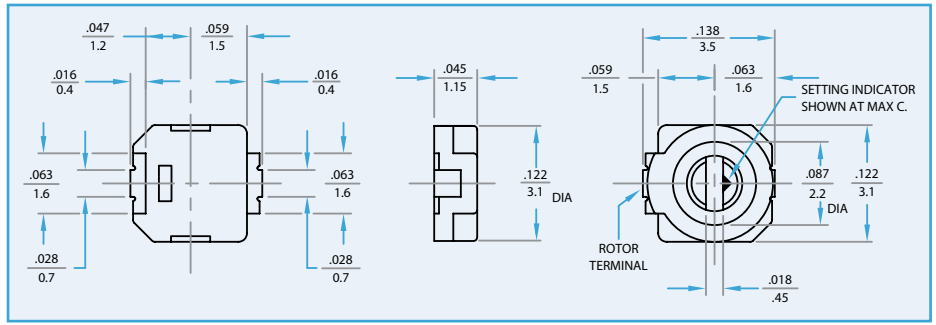

General specifications

Part No. JR Series	JR030	JR060	JR080	JR100	JR150	JR200	JR300	JR400	JR500
DC Working Voltage	125	125	125	125	125	125	125	125	125
DC Withstanding Voltage	250	250	250	250	250	250	250	250	250

Part No. JR_HV Series	JR030HV	JR060HV	JR080HV	JR100HV	JR150HV	JR200HV	JR300HV	JR400HV
DC Working Voltage	350	350	350	350	350	350	350	350
DC Withstanding Voltage	700	700	700	700	700	700	700	700

Capacitance (pF)	Minimum Maximum	1.5 3.0	2.0 6.0	3.0 8.0	2.0 10.0	3.0 15.0	4.5 20.0	5.5 30.0	8.0 40.0	8.0 50.0
Marking Color*		Black	Blue	Violet	White	Pink	Red	Orange	Yellow	Green
Temperature Coefficient (ppm/°C)		0 ± 200	0 ± 300	-750 ± 500	0 ± 300	0 ± 500	0 ± 500	-1500 ± 1000	-1500 ± 1000	-1500 ± 1000
Approximate Self Resonant Frequency at Maximum Rated Capacitance	JR & JR_HV Series	2.9GHz	2.05GHz	1.8GHz	1.6GHz	1.3GHz	1.15GHz	0.92GHz	0.84GHz	-
Insulation Resistance		10 ⁴ MΩ								
Operating Temperature		-40°C to +85°C (Tunable temp range -25°C to +85°C)								
Torque		0.6 in-oz max.								
Packaging		All parts furnished on 12mm tape and reel. 1,000 pcs. per reel.								

* HV parts are indicated by a second, green dot.

Solder Pad Layout

Recommended thickness of solder paste 0.15mm

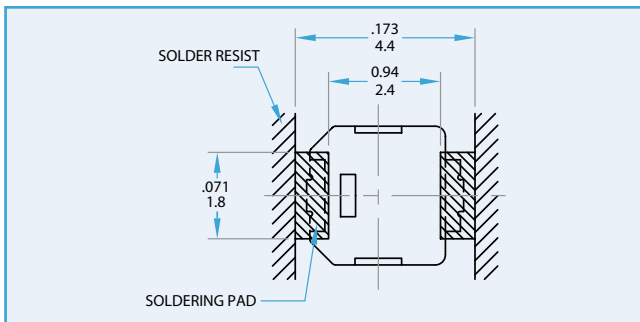

Recommended Reflow Solder Temperature Profile

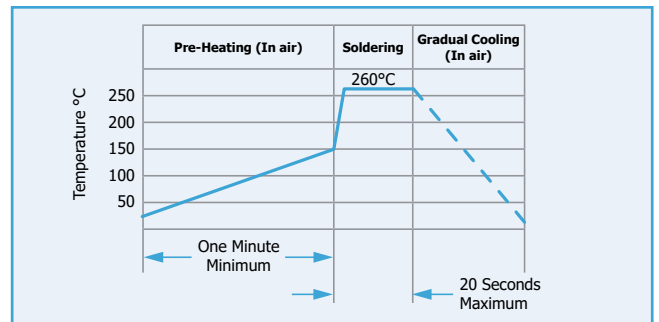

Recommended Tuning Tools

Ceramic Tipped: TT-400

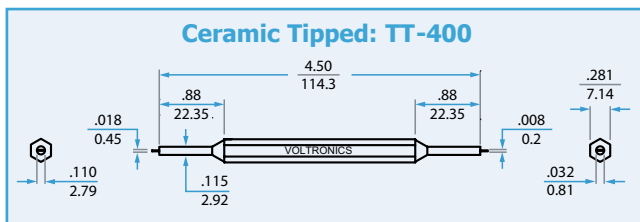

Ceramic Tipped: TT-900

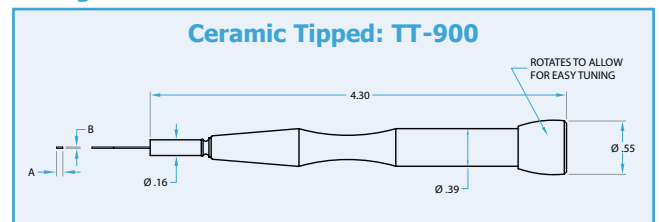

The Thin-Trim® 9401 Series capacitors are an advanced development in miniaturized trimmers for applications in circuits where size and performance are critical. These one-half turn ceramic capacitors feature high Q performance up to 2GHz and beyond.

The 9401 Series construction incorporates a butterfly electrode pattern which provides a series parallel capacitor with extremely low ESR and ESL. Johanson's square drive tuning mechanism insures captive, non-slip, tamper-proof adjustments eliminating backlash problems.

Characteristics

Rated voltage: 250 VDC (test voltage 500 VDC)

- Insulation resistance: $>10^4$ M Ω
- Operating temperature range: -55°C to +125°C
- Torque: 0.05 to 0.5 oz. in.
- Vibration: 15g, 10-2000 Hz
- Shock: 100g, 6 milliseconds
- Setting drift: $<1\%$
- Moisture resistance: MIL-STD-202, Method 106
- Resistant to soldering heat: MIL-STD-202, Method 210, Test C
- Solderability: MIL-STD-202, Method 208
- Resistant to cleaning solvents: MIL-STD-202, Method 215

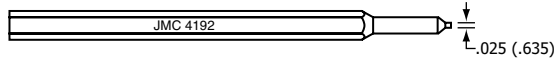

JMC Square Drive Tuning Tool 4192

Applications

- RF amplifier
- LC Filters and Networks
- Broadband Wireless LAN
- Medical Devices
- Cordless and Cellular phones
- DR/Crystal Oscillator
- Microstrip line filters

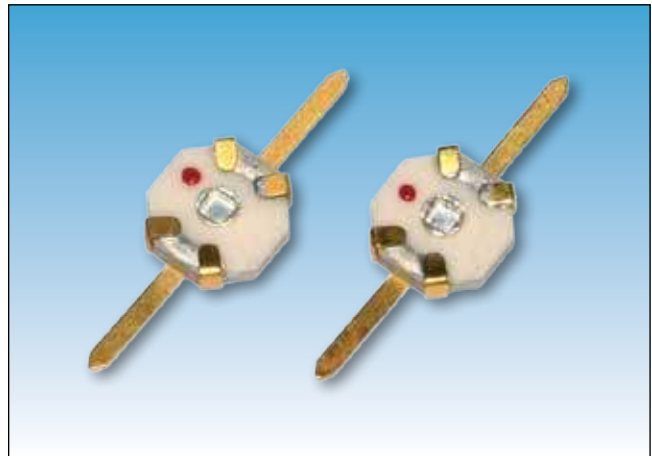

Packaging

Tape and reel available for SL products
Add suffix to JMC P/N for reel packaging
R1 = 1500 pieces, R4 = 6000 pieces

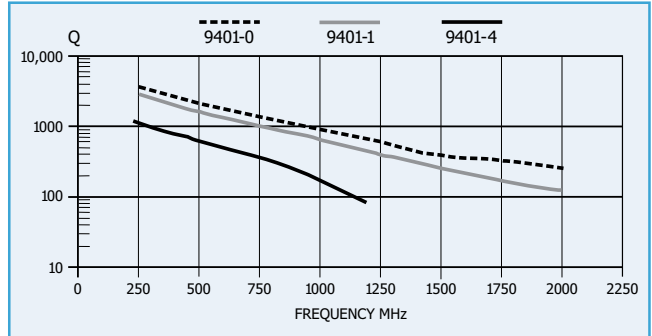

Series	Housing Size	Capacitance	Tuning Resolution	Min. Q @ 100 MHz	Color Code	Drawing Figure
9401-0	0.125" (3.18mm)	0.25 to 0.7pF	90°	>1000	Red	A
9401-0SL-1	0.125" (3.18mm)	0.25 to 0.7pF	90°	>1000	Red	B
9401-1	0.125" (3.18mm)	0.5 to 1.3pF	90°	>1000	Black	A
9401-1SL-1	0.125" (3.18mm)	0.5 to 1.3pF	90°	>1000	Black	B
9401-2	0.125" (3.18mm)	0.6 to 2pF	90°	>1000	Blue	A
9401-2SL-1	0.125" (3.18mm)	0.6 to 2pF	90°	>1000	Blue	B
9401-4	0.125" (3.18mm)	1.5 to 4pF	90°	>500	Brown	A
9401-4SL-1	0.125" (3.18mm)	1.5 to 4pF	90°	>500	Brown	B

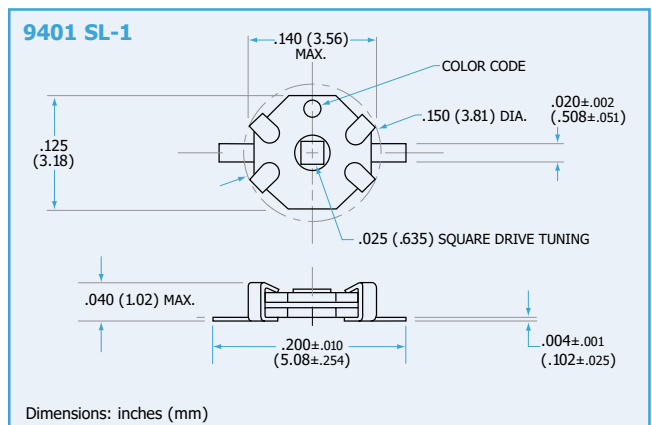
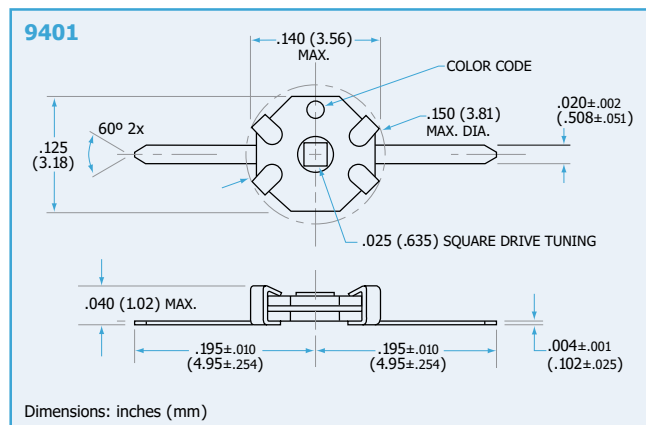

Thin-Trim® 9402 & 9410 Series capacitors are an advanced development in miniaturized trimmer capacitors for applications in circuits where size and performance are critical.

The Thin-Trim® capacitor embodies a radical reduction in size and weight over standard ceramic capacitors, with a proportional improvement in electrical characteristics. The capacitor consists of a metallic rotor suspended under spring pressure between two metalized dielectric disks. In addition to physically securing the assembly, the springs serve as both the internal electrical connection and the external terminals, simplifying the construction and further reducing size. The incorporation of the Johanson square drive tuning mechanism insures captive, non-slip, tamper-proof adjustments which are not subject to backlash problems associated with screwdriver type adjustments.

Characteristics

Rated voltage: 250 VDC (test voltage 500 VDC)

- Insulation resistance: $>10^4$ M Ω
- Operating temperature range: -55°C to +125°C
- Torque: 0.05 to 1.0 oz. in.
0.2 to 2.0 oz. in. for 9410
- Vibration: 15g, 10-2000 Hz
- Shock: 100g, 6 milliseconds
- Setting drift: <1%
- Moisture resistance: MIL-STD-202, Method 106
- Resistant to soldering heat: MIL-STD-202, Method 210, Test C
- Solderability: MIL-STD-202, Method 208
- Resistant to cleaning solvents: MIL-STD-202, Method 215

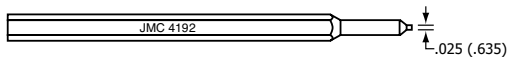

JMC Square Drive Tuning Tool 4192 for 9402

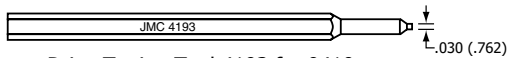

JMC Square Drive Tuning Tool 4193 for 9410

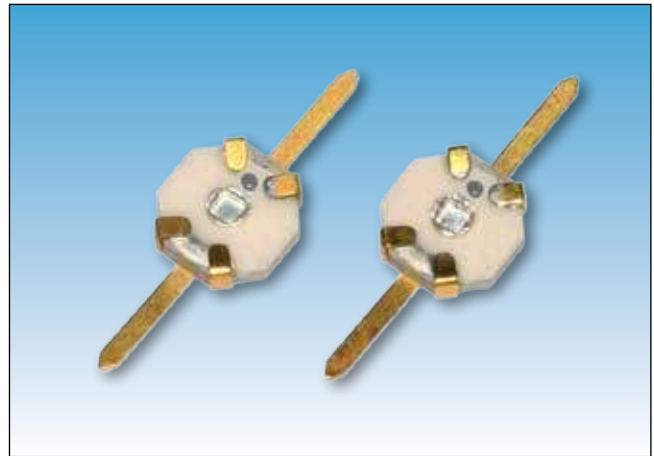

Packaging

Tape and reel available for 9402-SL & 9410-SL products
Add suffix to JMC P/N for reel packaging
9410-SL R7 = 3000 pieces

Applications

- RF amplifier
- LC Filters and Networks
- Broadband Wireless LAN
- Medical Devices
- Cordless and Cellular phones
- DR/Crystal Oscillator
- Microstrip line filters

Series	Housing Size	Capacitance	Tuning Resolution	Min. Q @ 100 MHz	Color Code	Drawing Figure
9402-0	0.125" (3.18mm)	0.5 to 2.5pF	180°	3000	Red	A
9402-0SL-1	0.125" (3.18mm)		180°			B
9402-1	0.125" (3.18mm)	1.0 to 5.0pF	180°	1000	Black	A
9402-1SL-1	0.125" (3.18mm)		180°			B
9402-2	0.125" (3.18mm)	2.5 to 10pF	180°	1000	Blue	A
9402-2SL-1	0.125" (3.18mm)		180°			B
9402-4	0.125" (3.18mm)	3.0 to 12pF	180°	500	Brown	A
9402-4SL-1	0.125" (3.18mm)		180°			B
9402-6	0.125" (3.18mm)	6.0 to 25pF	180°	300	Yellow	A
9402-6SL-1	0.125" (3.18mm)		180°			B
9402-8	0.125" (3.18mm)	5.0 to 15pF	180°	750	None	A
9402-8SL-1	0.125" (3.18mm)		180°			B
9402-9	0.125" (3.18mm)	5.0 to 18pF	180°	500	Grey	A
9402-9SL-1	0.125" (3.18mm)		180°			B
9410-0	0.200" (5.08mm)	1.0 to 4.5pF	180°	1000	Red	C
9410-0SL-1	0.200" (5.08mm)		180°			D
9410-1	0.200" (5.08mm)	2.5 to 10pF	180°	1000	Black	C
9410-1SL-1	0.200" (5.08mm)		180°			D
9410-2	0.200" (5.08mm)	4.0 to 18pF	180°	700	Blue	C
9410-2SL-1	0.200" (5.08mm)		180°			D
9410-3	0.200" (5.08mm)	6.0 to 35pF	180°	200	Orange	C
9410-3SL-1	0.200" (5.08mm)		180°			D
9410-4	0.200" (5.08mm)	7.0 to 40pF	180°	200	Brown	C
9410-4SL-1	0.200" (5.08mm)		180°			D
9410-5	0.200" (5.08mm)	8.0 to 50pF	180°	200	Green	C
9410-5SL-1	0.200" (5.08mm)		180°			D
9410-25	0.200" (5.08mm)	5.0 to 25pF	180°	200	Yellow	C
9410-25SL-1	0.200" (5.08mm)		180°			D

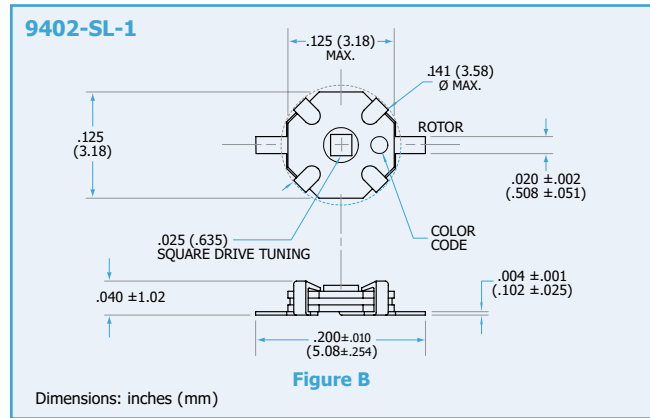
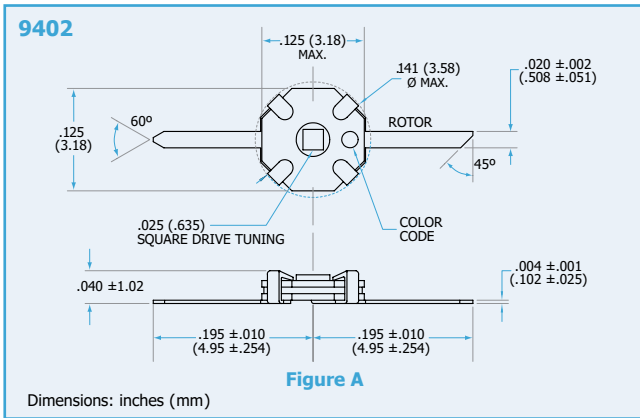

Q VS. Frequency 9402 Series

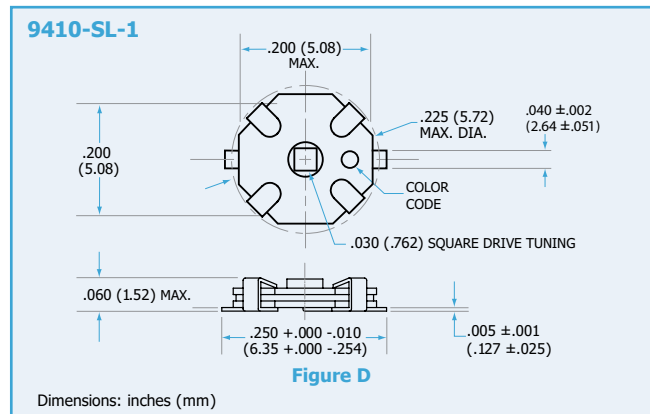
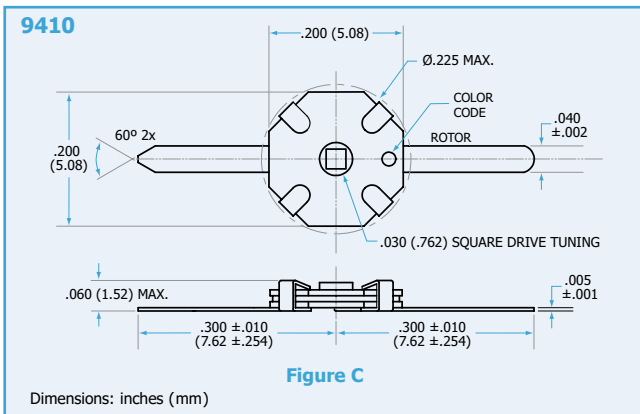
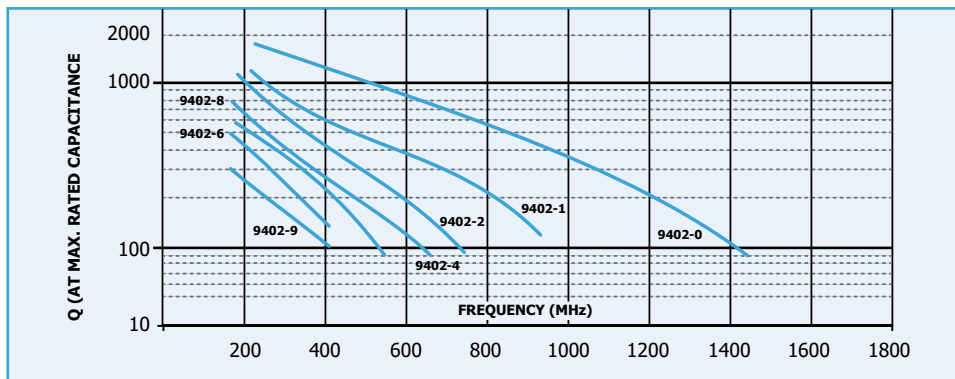

Q VS. Frequency 9410 Series

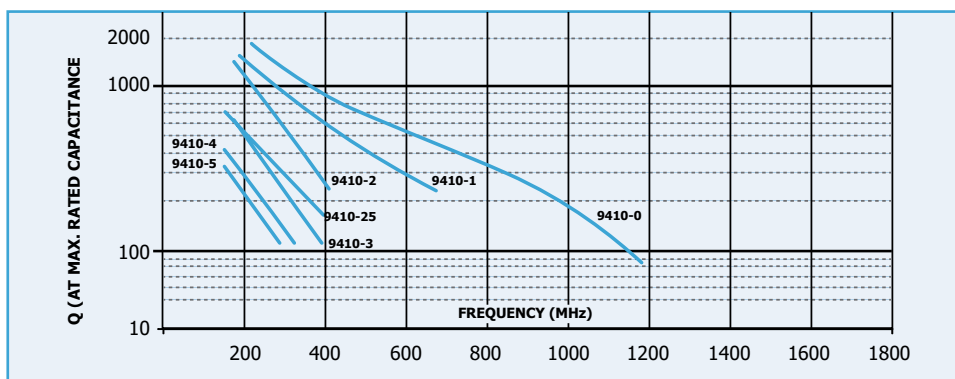

Thin-Trim® 9702 & 9710 Series capacitors are an advanced development in miniaturized trimmer capacitors for applications in circuits where size and performance are critical.

The Thin-Trim® capacitor embodies a radical reduction in size and weight over standard ceramic capacitors, with a proportional improvement in electrical characteristics. The capacitor consists of two metallic rotor suspended under spring pressure between two metalized dielectric disks. In addition to physically securing the assembly, the springs serve as both the internal electrical connection and the external terminals, simplifying the construction and further reducing size. The incorporation of the Johanson square drive tuning mechanism insures captive, non-slip, tamper-proof adjustments which are not subject to backlash problems associated with screwdriver type adjustments.

Characteristics

Rated voltage: 250 VDC (test voltage 500 VDC)

- Insulation resistance: $>10^4$ M Ω
- Operating temperature range: -55°C to +125°C
- Torque: 0.05 to 1.0 oz. in. for 9702
0.2 to 2.0 oz. in. for 9710
- Vibration: 15g, 10-2000 Hz
- Shock: 100g, 6 milliseconds
- Setting drift: $<1\%$
- Moisture resistance: MIL-STD-202, Method 106
- Resistant to soldering heat: MIL-STD-202, Method 210, Test C
- Solderability: MIL-STD-202, Method 208
- Resistant to cleaning solvents: MIL-STD-202, Method 215
- RoHS compliant

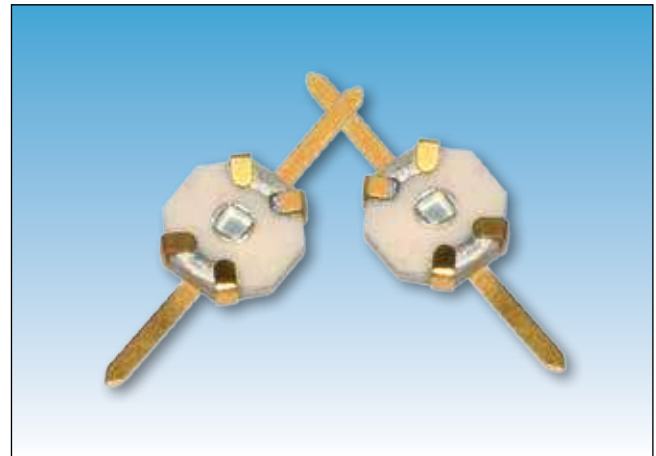

Packaging

Tape and reel available for 9702 & 9710 products
Add suffix to JMC P/N for reel packaging

Applications

- RF amplifier
- LC Filters and Networks
- Broadband Wireless LAN
- Medical Devices
- Cordless and Cellular phones
- DR/Crystal Oscillator
- Microstrip line filters

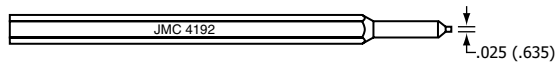

JMC Square Drive Tuning Tool 4192 for 9702

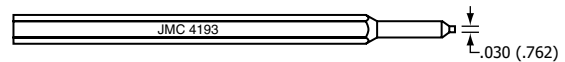

JMC Square Drive Tuning Tool 4193 for 9710

Series	Housing Size	Capacitance	Tuning Resolution	Min. Q @ 100 MHz	Drawing Figure
9702-0	0.125" (3.18mm)	0.5 to 2.5pF	180°	3000	A
9710-0	0.200" (5.08mm)	1.0 to 4.5pF	180°	1000	B
9702-1	0.125" (3.18mm)	1.0 to 5.0pF	180°	1000	A
9702-2	0.125" (3.18mm)	2.5 to 10pF	180°	1000	A
9710-1	0.200" (5.08mm)		180°	1000	B
9702-4	0.125" (3.18mm)	3.0 to 12pF	180°	500	A
9710-2	0.200" (5.08mm)	4.0 to 18pF	180°	700	B
9702-8	0.125" (3.18mm)	5.0 to 15pF	180°	750	A
9702-5	0.125" (3.18mm)	5.0 to 20pF	180°	500	A
9710-7	0.200" (5.08mm)	5.0 to 25pF	180°	500	B
9710-3	0.200" (5.08mm)	6.0 to 35pF	180°	200	B
9702-9	0.125" (3.18mm)	7.0 to 18pF	180°	500	A
9710-4	0.200" (5.08mm)	7.0 to 40pF	180°	200	B
9702-6	0.125" (3.18mm)	8.0 to 25pF	180°	300	A
9710-5	0.200" (5.08mm)	10.0 to 50pF	180°	200	B

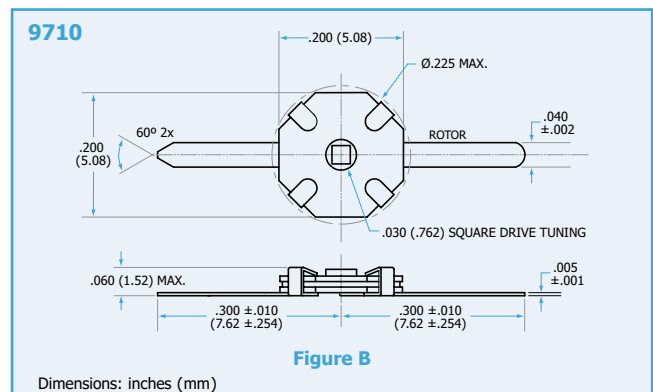
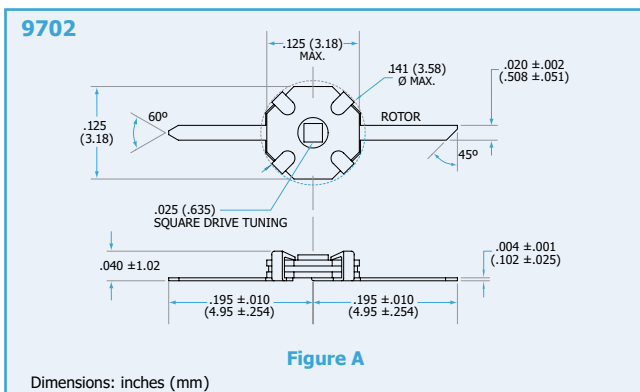

Cera-Trim® is a high performance surface mount trimmer capacitor designed specifically to withstand harsh environments. These capacitors deliver exceptional performance through microwave frequencies at operating temperatures of -55°C to +125°C. The square drive tuning mechanism provides and assures complete compatibility with automated tuning devices for positive non-slip tamper-proof adjustments.

The Cera-Trim® design makes it possible to utilize tape and reel. The alumina housing provides mechanical strength with outstanding electrical and heat resistant properties. The rugged construction renders it resistant to penetration of solder fluxes and cleaning solvents. Recommended handling instructions outlining soldering procedures are available in Johanson specification R-360.

Characteristics

Rated voltage: 250 VDC (test voltage 500 VDC)

- Insulation resistance: $>10^4$ MΩ
- Operating temperature range: -55°C to +125°C
- Vibration: 15g, 10-2000 Hz, MIL-STD-202, Method 204, Condition B
- Shock: 100g, 6 milliseconds, MIL-STD-202, Method 213, Condition I
- Moisture resistance: MIL-STD-202, Method 106
- Resistant to soldering heat and flux: 260°C for 10 seconds
- Solderability: MIL-STD-202, Method 208
- Withstands up to 5 minutes total immersion in typical cleaning solvents at room temperature
- Conforms with specification MIL-C-81
- RoHS compliant Series

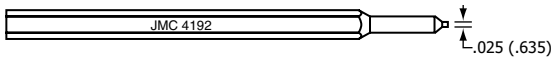

JMC Square Drive Tuning Tool 4192 for 2320 & 2322 Series



Packaging

Add suffix to JMC P/N for reel packaging
R1 = 500 pieces, R2 = 2,500 pieces

Applications

- RF amplifier
- LC Filters and Networks
- Broadband Wireless LAN
- Medical Devices
- Cordless and Cellular phones
- DR/Crystal Oscillator
- Microstrip line filters

2320 Series	2322 RoHS Series	Housing Size	2320 Capacitance	2322 RoHS Capacitance	Tuning Resolution	Min. Q @ 100MHz	Color Codes Std./RoHS	Drawing Figure
2320-0	2322-0G	0.180" x 0.167" (4.57 x 4.24mm)	0.6 to 2.5pF	0.6 to 2.5pF	180°	3000	Red/Red	A
2320-0SL	2322-0GSL	0.180" x 0.167" (4.57 x 4.24mm)	0.6 to 2.5pF	0.6 to 2.5pF	180°	3000	Red/Red	B
2320-1	2322-1G	0.180" x 0.167" (4.57 x 4.24mm)	1.0 to 5pF	1.0 to 5pF	180°	1000	Black/Blue	B
2320-1SL	2322-1GSL	0.180" x 0.167" (4.57 x 4.24mm)	1.0 to 5pF	1.0 to 5pF	180°	1000	Black/Blue	A
2320-2	2322-2G	0.180" x 0.167" (4.57 x 4.24mm)	2.5 to 10pF	2.5 to 10pF	180°	1000	Blue/Black	A
2320-2SL	2322-2GSL	0.180" x 0.167" (4.57 x 4.24mm)	2.5 to 10pF	2.5 to 10pF	180°	1000	Blue/Black	B
2320-3	2322-3G	0.180" x 0.167" (4.57 x 4.24mm)	5 to 18pF	7.5 to 18pF	180°	500	Green/Clear	B
2320-3SL	2322-3GSL	0.180" x 0.167" (4.57 x 4.24mm)	5 to 18pF	7.5 to 18pF	180°	500	Green/Clear	A
2320-4	2322-4G	0.180" x 0.167" (4.57 x 4.24mm)	6.5 to 25pF	8.5 to 25pF	180°	300	Amber/Green	A
2320-4SL	2322-4GSL	0.180" x 0.167" (4.57 x 4.24mm)	6.5 to 25pF	8.5 to 25pF	180°	300	Amber/Green	B

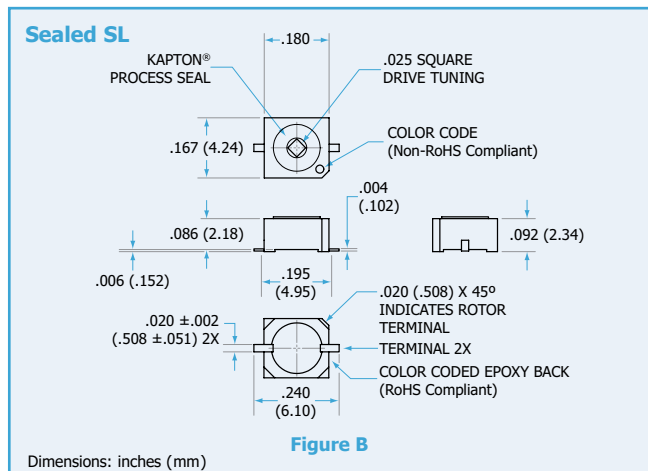
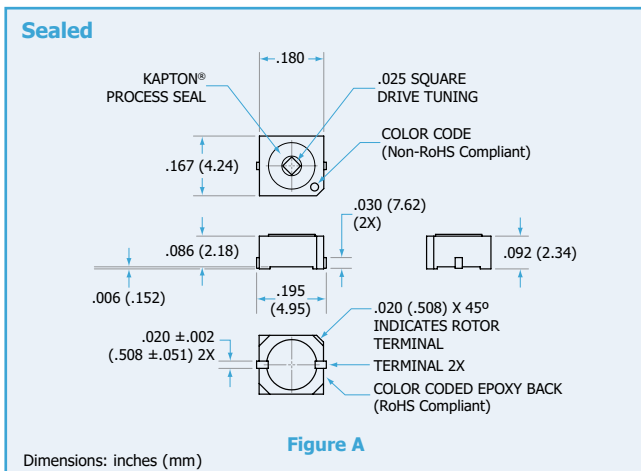

The Seal-Trim® is a high performance Thin-Trim® trimmer ceramic capacitor encapsulated in a polymer housing. This design resists intrusion of dirt, dust, solder flux and cleaning agents during assembly and atmospheric contamination during use. These capacitors offer low drift rates and high Q, making them ideal for higher frequency applications beyond the limits of ordinary ceramic trimmer capacitors. The incorporation of the Johanson square drive tuning mechanism insures captive non-slip, tamper-proof adjustments which are not subject to backlash problems associated with screwdriver type adjustment slots.

Characteristics

Rated voltages:

250 VDC (test voltage 500 VDC) for 9610, 9620, 9810 & 9820
 400 VDC (test voltage 800 VDC) for 9694

- Insulation resistance: $>10^4 \text{ M}\Omega$
- Operating temperature range: -55°C to $+125^\circ\text{C}$
- Torque: 0.2 to 2.0 for 9610, 9694
 0.05 to 1.0 for 9620
- Vibration: 15g, 10-2000 Hz, MIL-STD-202, Method 204
- Shock: 100g, 6 milliseconds, MIL-STD-202, Method 21
- Setting drift: $<1\%$; $<2\%$ for 9616, 9694
- Moisture resistance: MIL-STD-202, Method 106
- Resistant to soldering heat: MIL-STD-202, Method 210, Test C
- Solderability: MIL-STD-202, Method 208



- Resistant to cleaning solvents: MIL-STD-202, Method 215
- RoHS compliant Series

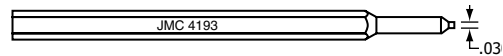

JMC Drive Tuning Tool 4193 for 9610, 9620, 9810 & 9820 Series

9610 Series	9810 RoHS Series	Housing Size	9610 Capacitance	9810 RoHS Capacitance	Tuning Resolution	Min. Q @ 100 MHz	Drawing Figure
9610	9810	0.270" (6.86mm)	1 to 4.5pF	1 to 4.5pF	180°	>1000	A
9610-SL	9810-SL	0.270" (6.86mm)			180°		B
9611	9811	0.270" (6.86mm)	2.5 to 10pF	2.5 to 10pF	180°	>1000	A
9611-SL	9811-SL	0.270" (6.86mm)			180°		B
9612	9812	0.270" (6.86mm)	4 to 18pF	4 to 18pF	180°	>700	A
9612-SL	9812-SL	0.270" (6.86mm)			180°		B
9613	9813	0.270" (6.86mm)	6 to 35pF	6 to 35pF	180°	>200	A
9613-SL	9813-SL	0.270" (6.86mm)			180°		B
9614	9814	0.270" (6.86mm)	7 to 40pF	7 to 40pF	180°	>200	A
9614-SL	9814-SL	0.270" (6.86mm)			180°		B
9615	9815	0.270" (6.86mm)	5 to 25pF	5 to 25pF	180°	>200	A
9615-SL	9815-SL	0.270" (6.86mm)			180°		B
9616	9816	0.270" (6.86mm)	8 to 50pF	10.5 to 50pF	180°	>200	A
9616-SL	9816-SL	0.270" (6.86mm)			180°		B

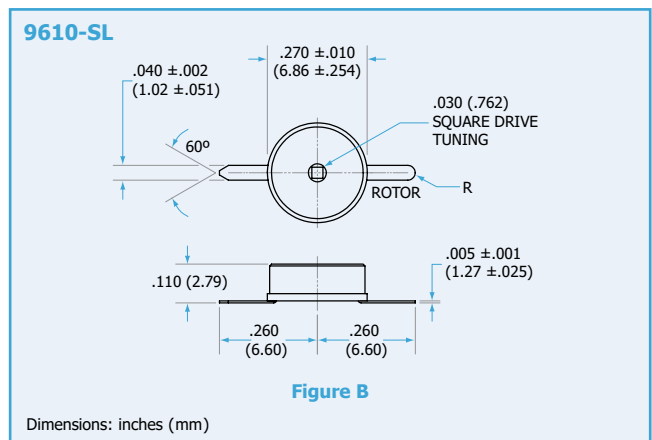
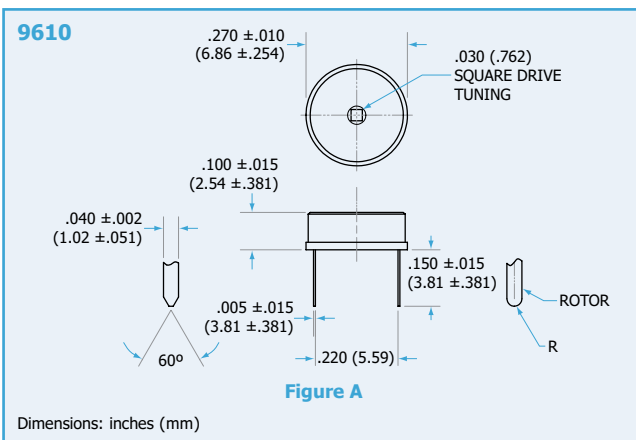





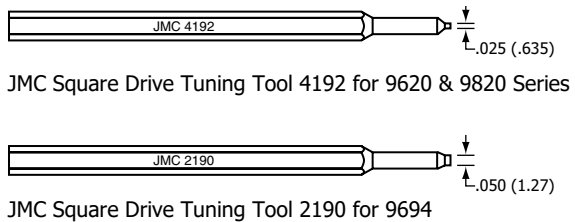
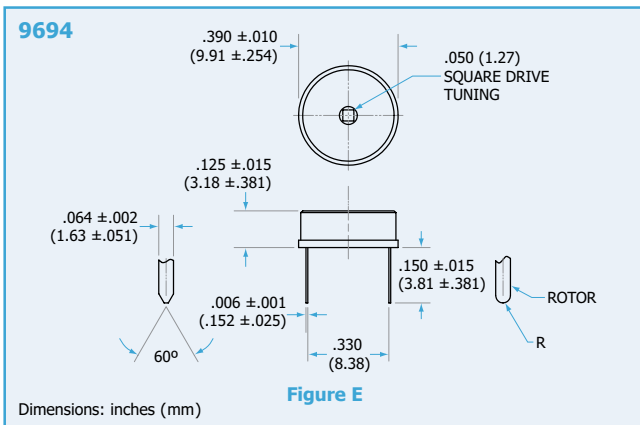
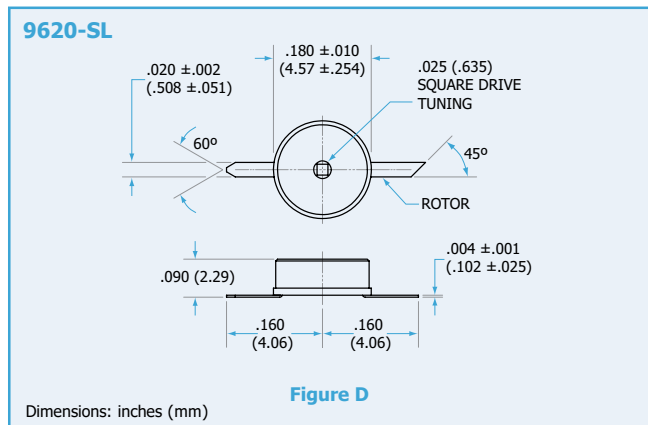
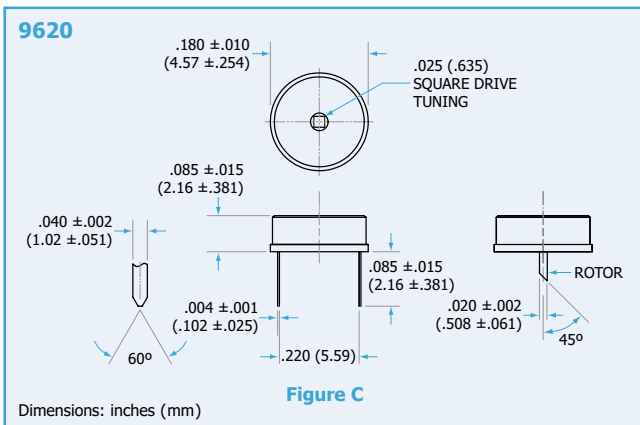





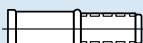

9620 Series	9820 RoHS Series	Disk Size	9620 Capacitance	9820 RoHS Capacitance	Tuning Resolution	Min. Q @ 100 MHz	Drawing Figure
9620	9820	0.180" (4.57mm)	0.5 to 2.5pF	0.5 to 2.5pF	180°	>1000	C
9620-SL	9820-SL	0.180" (4.57mm)			180°		D
9621	9821	0.180" (4.57mm)	1.0 to 5.0pF	1.0 to 5.0pF	180°	>1000	C
9621-SL	9821-SL	0.180" (4.57mm)			180°		D
9622	9822	0.180" (4.57mm)	2.5 to 10pF	2.5 to 10pF	180°	>1000	C
9622-SL	9822-SL	0.180" (4.57mm)			180°		D
9626	9826	0.180" (4.57mm)	6 to 25pF	8.5 to 25pF	180°	>300	C
9626-SL	9826-SL	0.180" (4.57mm)			180°		D
9628	9828	0.180" (4.57mm)	5 to 15pF	5 to 15pF	180°	>750	C
9628-SL	9828-SL	0.180" (4.57mm)			180°		D
9629	9829	0.180" (4.57mm)	5 to 20pF	7.5 to 20pF	180°	>500	C
9629-SL	9829-SL	0.180" (4.57mm)			180°		D
9694	-	0.390" (9.91mm)	7.5 to 50pF	-	180°	>1000 @ 1 MHz	E



Product Selection Guide - Consult Factory for Complete Catalog

Product Line	Description	Series	Maximum Capacitance	Maximum DC Working Voltage	Typical minimum Q value	Page
A1_4/8  A1_12 	Miniature PTFE Dielectric	NM or A4_HV	12pF	1000	2000 - 4000	22
A4_3  A4_5 		NM or A1_HV	5pF	1000	2000 - 3000	23
A_HV 	High Voltage PTFE Dielectric	NM or A_HV	30pF	1000	2000	24
A_HV Ext Range 		NM or A_HV	55pF ext. range	1000	780 - 2000	24
K_HV 		NM or K_HV	15pF	1000	780 - 2000	25
NT 	20kV PTFE Dielectric	NM NT	95pF	10000	2000	27
GLASS  	Glass Dielectric	NM HTM NM TF NM TM NM TP	250pF 36pF 130pF 180pF	1250 1000 1250 1250	250 - 1000	34
QUARTZ 	Quartz Dielectric	NM QM	24pF	1250	2000	34

Note: Most of the above trimmer capacitors can be ordered as non-magnetic - see non-magnetic section.

Johanson Part No.	Capacitance Range (pF)	Number of Turns	Working Voltage (VDC)	Tuning Torque (oz. in)	Q @ 100 MHz	Page
5200	0.8 to 10pF	>6	250	1 - 5	>5000	17
5201						16
5202						17
5302	1 to 10pF	>10	500	1 - 6	>2000	17
5400	1 to 14pF	>6	250	1 - 5	>3000	17
5401						16
5402						17
5451	1 to 16pF	>6	250	1 - 5	>3000	16
5453	1.5 to 16pF					18
5500	1 to 20pF	>12	250	1 - 5	>1500	17
5501						16
5502						17
5600	1 to 30pF	>20	250	1 - 5	>800	17
5601						16
5602						17
5700	0.6 to 6pF	>7	250	0.4 - 4	>10000	16
5701						16
5702						17
5750	0.8 to 10pF	>8	250	0.4 - 4	>7500	16
5751						16
5752						17
5753	1 to 10pF					18
5800	0.35 to 3.5pF	>9	250	0.3 - 3	>10000	17
5801						16
5802						17
5850	0.5 to 5pF	>12	250	0.3 - 3	>7500	17
5851						16
5852						17
5853	0.6 to 5pF					18
8050	0.7 to 6pF	>7	250	0.4 - 4	>10000	18
8051	0.6 to 3.5pF	>10		0.3 - 3		
8052	1 to 10pF	>6		1 - 5	>5000	
8053	1.5 to 14pF	>6			>3000	
8054	1.5 to 20pF	>12			>1500	
8090	1 to 10pF	>6	250	1 - 5	>2000	
8091						
8092	1.5 to 14pF					
8093						

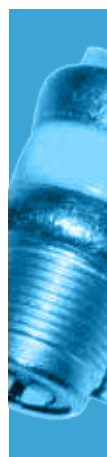



P Lead Style

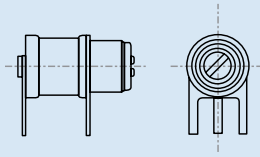

B Lead Style

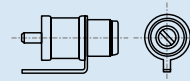

F Lead Style



M Lead Style

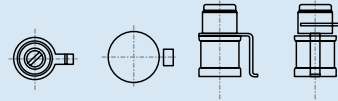

T Lead Style

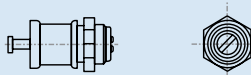

C Lead Style

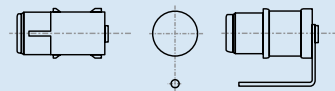

J Lead Style

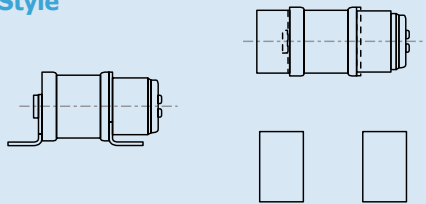

D Lead Style

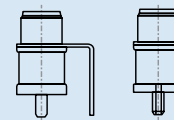

T Lead Style with L option

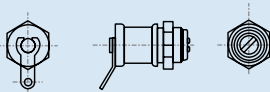

E Lead Style

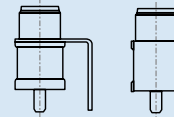

Note: All bushing threads are .234" -64

Extended Metal Shaft

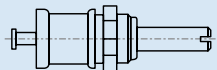

Insulated Bushing

Insert "I" in Part Number, i.e. AIT10L

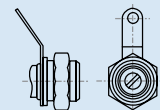

The only internally sealed Air Trimmer

Voltronics' concentric ring Air Trimmer capacitors are designed for use at frequencies up to 1.5 GHz. They are ideal for applications such as mobile radios, aerospace communication, crystal oscillators and filters, radar, cable TV and innumerable other commercial and military programs. The unique internal O-ring seal make wave soldering and vapor degreasing possible without the need to attach a separate cap.

"A" Series - Solder sealed and qualified to MIL-C-14409.

Other features include:

- Ten full linear turns
- Internal stops
- Extreme stability under shock and vibration
- Screw head does not move in and out
- Extended shaft option of metal or plastic
- Long life with no dynamic tuning noise

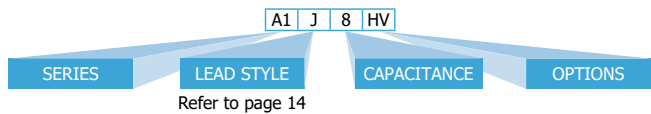

Note:

All parts shown here can be ordered as non-magnetic: Add "NM" to Part Number, i.e., NMAP10

General Specifications	A_5	A_10	A_14
Capacitance Range	1.0 - 5pF	1.0 - 10pF	1.0 - 14pF
Q (min) at 100MHz @ Max. C*	5,000	5,000	3,000
DC Working Voltage	250	250	125
DC Withstanding Voltage	500	500	250
Temperature Coefficient	50±50 ppm/°C / -50±50 ppm/°C	50±50 ppm/°C / -50±50 ppm/°C	50±50 ppm/°C / -50±50 ppm/°C
Insulation Resistance @ 25°C	10 ⁶ MΩ	10 ⁶ MΩ	10 ⁶ MΩ
Seal	40 pounds/in ²	40 pounds/in ²	40 pounds/in ²
Operating Temperature	- 65°C to +125°C	- 65°C to +125°C	- 65°C to +125°C
Rotational Life	10000 Turns	10000 Turns	10000 Turns
Tuning Torque	0.5 to 5.0 in-oz	0.5 to 5.0 in-oz	0.5 to 5.0 in-oz
Shock	1,500g, 0.5 millisecs.	1,500g, 0.5 millisecs.	1,500g, 0.5 millisecs.
Vibration	50g at 10 - 2000 Hz	50g at 10 - 2000 Hz	50g at 10 - 2000 Hz

* Self-resonant frequency and Q are assured with no terminals on parts.

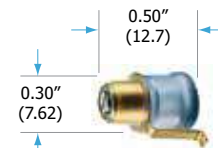
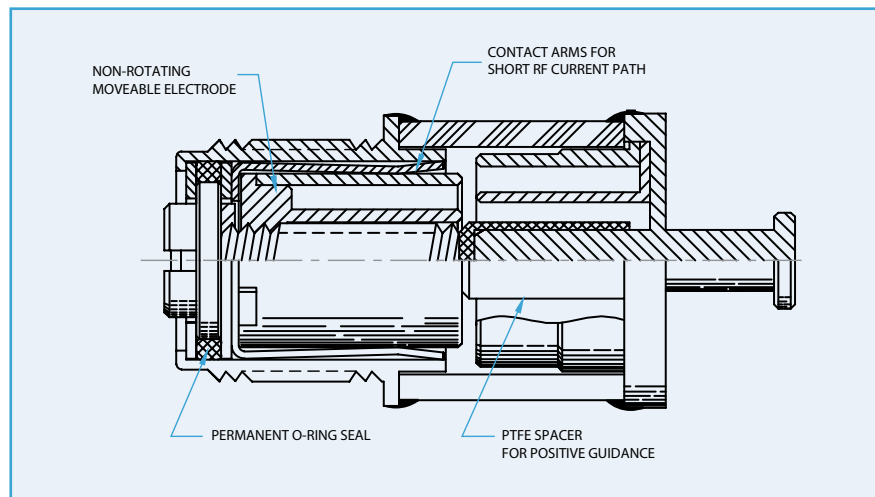

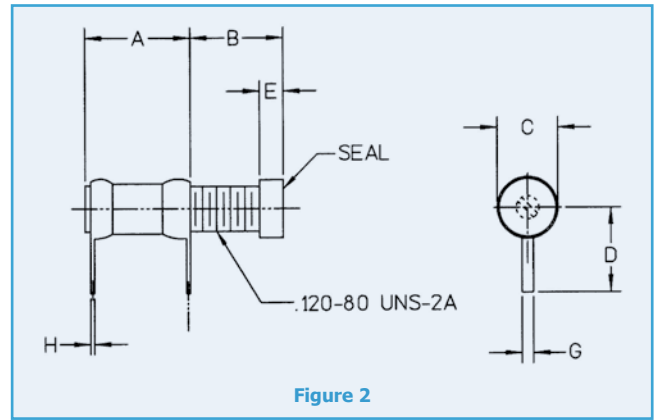
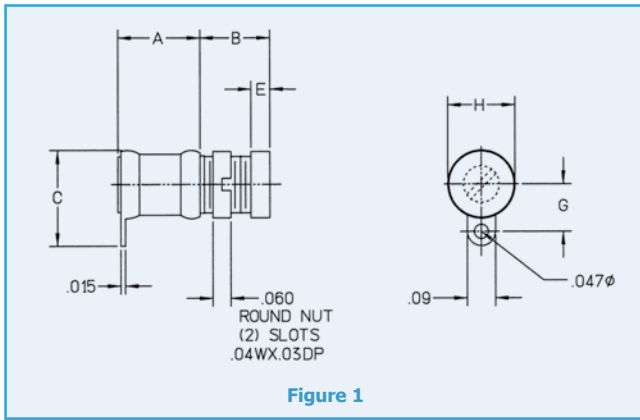

Part Number	Cap Range (pF)	Min. Q @ 100 MHz	Dimensions								Fig.
			A	B	C	D	E	F	G	(UNS-2A)	
5801	0.35 to 3.5	>10000	0.28	0.215	.160 .150	0.22	0.06	-	0.03	.120-80	2
5851	0.5 to 5.0	>7500	0.28	0.245	.160 .150	0.22	0.06	-	0.03	.120-80	2
5700	0.6 to 6.0	>10000	0.27	0.21	.235 .215	-	0.06	0.32	0.16	.190-64	1
5750	0.8 to 10.0	>7500	0.27	0.23	.235 .215	-	0.06	0.32	0.16	.190-64	1

Dimensions (inches)

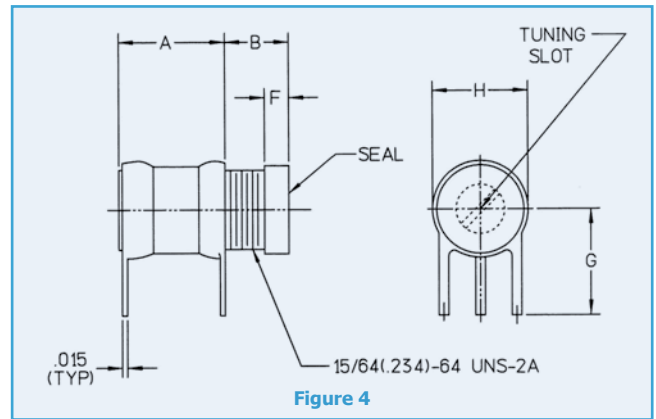
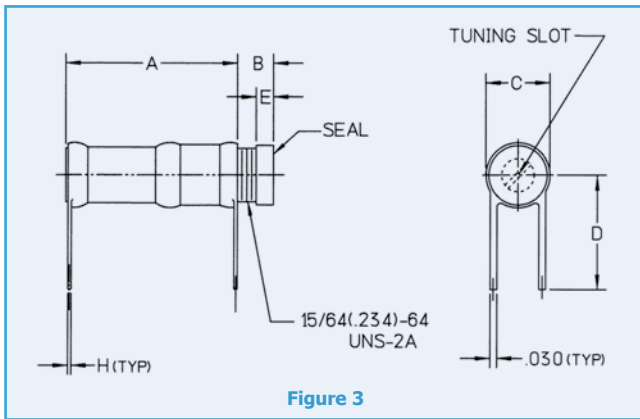

Part Number	Cap Range (pF)	Min. Q @ 100 MHz	Dimensions							Fig.
			A	B	C	D	E	F	(UNS-2A)	
5701	0.6 to 6.0	>10000	0.29	0.19	.235 .215	0.25	0.06	-	.190-64	4
5201 5751	0.8 to 10.0	>5000 >7500	0.32 0.29	0.19 0.22	.295 .275 .235 .215	0.31 0.25	0.08 0.06	-	.234-64 .190-64	4
5401	1.0 to 14.0	>3000	0.32	0.19	.310 .290	0.50	0.08	-	.234-64	4
5451	1.0 to 16.0	>3000	0.32	0.19	.235 .215	0.31	0.08	-	.234-64	4
5501	1.0 to 20.0	>1500	0.58	0.16	.295 .275	0.50	0.08	-	.234-64	4
5601	1.0 to 30.0	>800	0.76	0.16	.295 .275	0.50	0.08	-	.234-64	3

Dimensions (inches)

Note: All Air Trimmers are available with or without hardware. Hardware may be purchased separately.

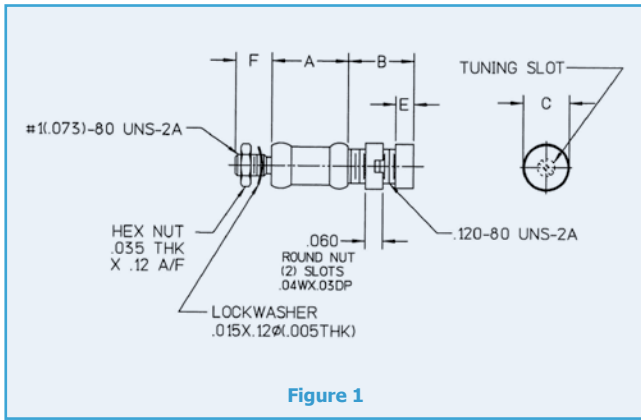

Figure 1

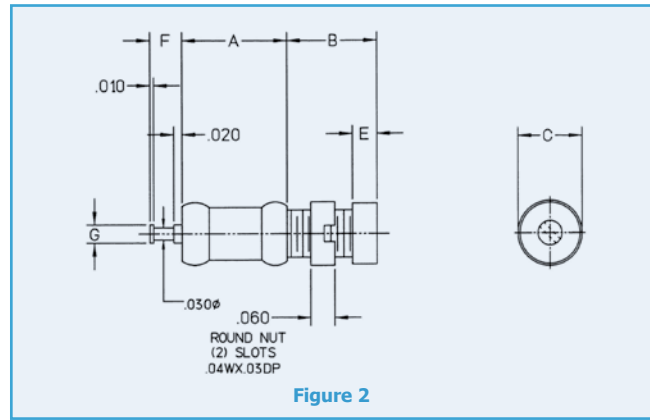

Figure 2

Part Number	Cap Range (pF)	Min. Q @ 100 MHz	Dimensions								Fig.	
			A	B	C	D	E	F	G	(UNS-2A)		
5800 5802	0.35 to 3.5	>10000	0.27	0.23	.160 .150	-	0.06	0.125 0.08	-	0.045	.120-80	1 2
5850 5852	0.5 to 5.0	>7500	0.27	0.26	.160 .150	-	0.06	0.125 0.08	-	0.045	.120-80	1 2
5702	0.6 to 6.0	>10000	0.27	0.21	.235 .215	-	0.06	0.08	0.06		.190-64	2
5752	0.8 to 10.0	>7500	0.27	0.23	.235 .215	-	0.06	0.08	0.06		.190-64	2

Dimensions (inches)

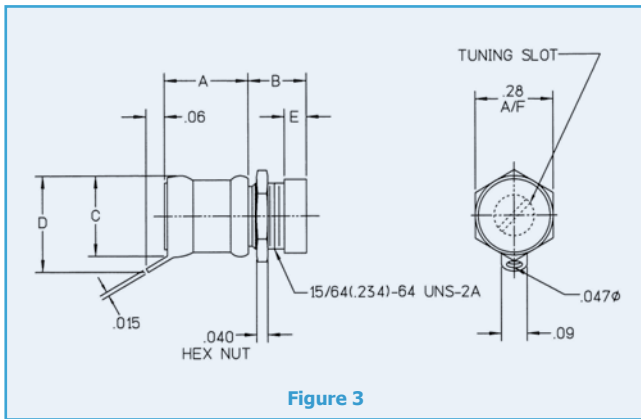

Figure 3

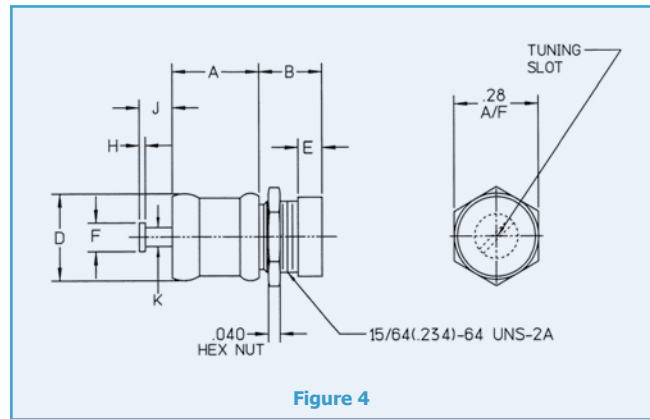
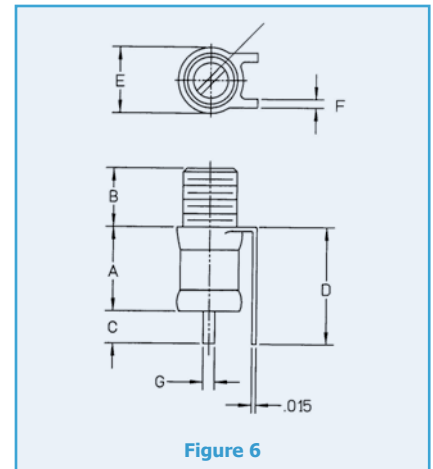
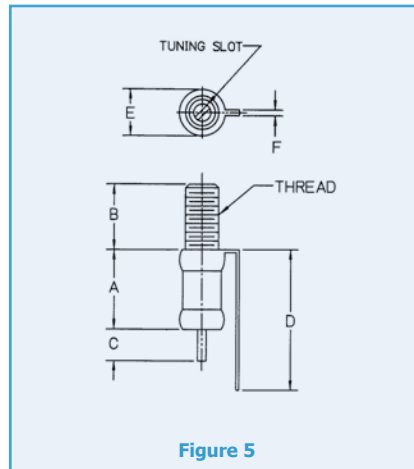
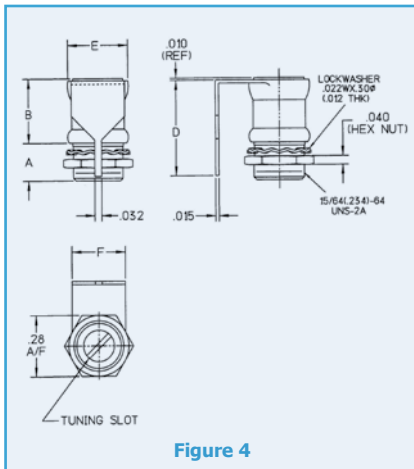
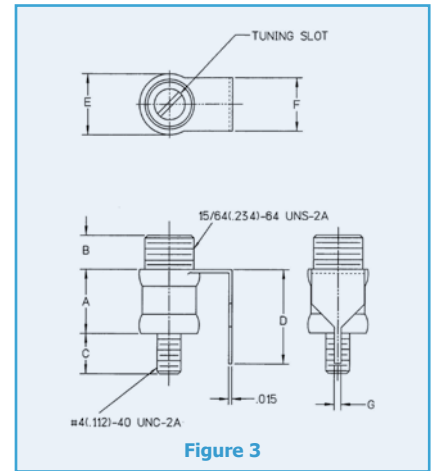
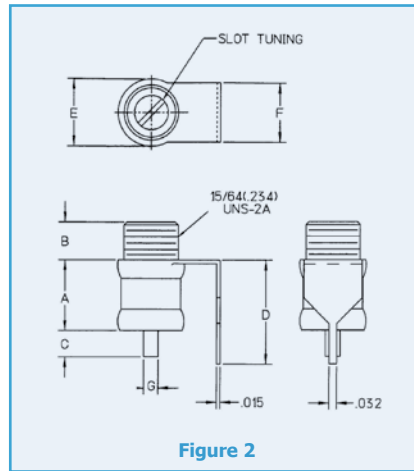
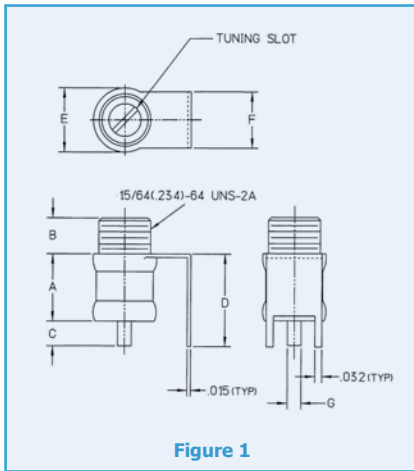

Figure 4

Part Number	Cap Range (pF)	Min. Q @ 100 MHz	Dimensions								Fig.	
			A	B	C	D	E	F	G	(UNS-2A)		
5200 5202	0.8 to 10.0	>5000	0.30 0.29	0.21	.295 .275	0.35 -	0.08	-	0.06	0.09	.234-64	3 4
5302	1.0 to 10.0	>2000	0.42	0.30	.375 .355	-	0.11	0.09	0.125		.312-64	4
5400 5402	1.0 to 14.0	>3000	0.30 0.29	0.21	.295 .275	0.35 -	0.08	-	0.06	0.09	.234-64	3 4
5500 5502	1.0 to 20.0	>1500	0.49	0.25	.295 .275	0.35 -	0.08	-	0.06	0.09	.234-64	3 4
5600 5602	1.0 to 30.0	>800	0.68	0.25	.295 .275	0.35 -	0.08	-	0.06	0.09	.234-64	3 4

Dimensions (inches)

Note: All Air Trimmers are available with or without hardware. Hardware may be purchased separately.



Part Number	Cap Range (pF)	Min. Q @ 100 MHz	Dimensions								Fig.
			A	B	C	D	E	F	G	(UNS-2A)	
8051	0.6 to 3.5	>10000	0.28	0.195	0.11	0.48	.160 .150	0.02	0.30	.120-80	5
5853	0.6 to 5.0	>7500	0.28	0.225	0.11	0.48	.160 .150	0.02	0.30	.120-80	5
8050	0.7 to 6.0	>10000	0.29	0.17	0.11	0.40	.235 .215	0.03	0.40	.190-64	5
5753	1.0 to 10.0	>7500	0.29	0.20	0.11	0.40	.235 .215	0.03	0.40	.190-64	6
8052	1.0 to 10.0	>5000	0.30	0.16	0.11	0.40	.295 .275	0.04	0.62	.234-64	5
8090	1.0 to 10.0	>2000	0.30	0.16	0.188	0.44	.295 .275	0.25	0.32	.234-64	3
8053	1.5 to 14.0	>3000	0.30	0.16	0.11	0.40	.295 .275	0.24	0.62	.234-64	5
8091	1.5 to 14.0	>2000	0.30	0.175	-	0.44	.295 .275	0.25	-	.234-64	4
8092	1.5 to 14.0	>2000	0.30	0.16	0.11	0.41	.295 .275	0.25	0.62	.234-64	1
8093	1.5 to 14.0	>2000	0.30	0.16	0.11	0.44	.295 .275	0.25	0.32	.234-64	2
5453	1.5 to 16.0	>3000	0.30	0.19	0.11	0.43	.295 .275	0.03	0.62	.234-64	6
8054	1.5 to 20.0	>1500	0.58	0.125	0.11	0.70	.295 .275	0.04	0.62	.234-64	5

Dimensions (inches)

Note: All Air Trimmers are available with or without hardware. Hardware may be purchased separately.

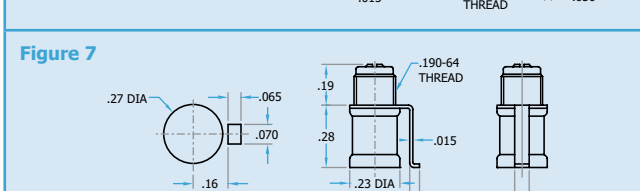
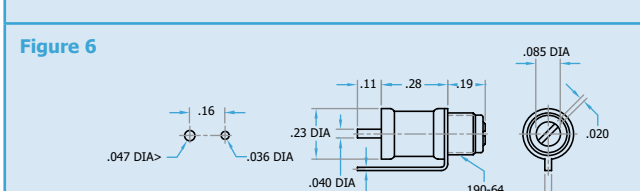
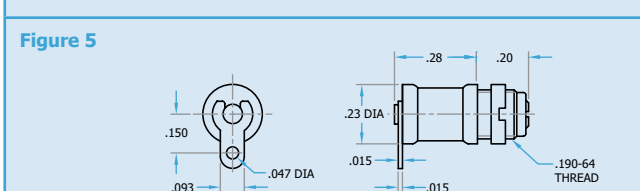
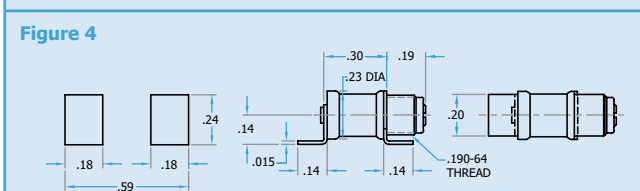
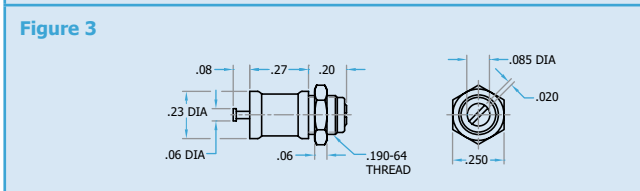
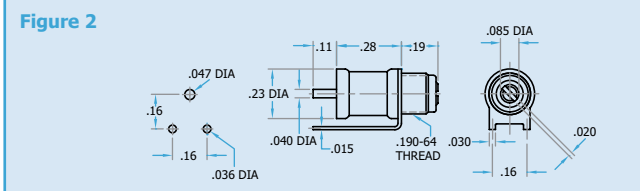
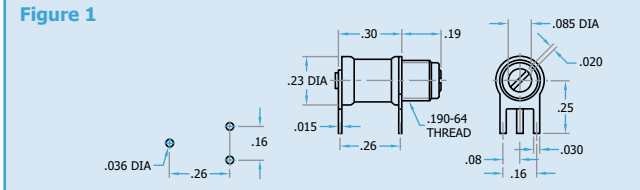

Note: All bushing threads are .190"-64

Part Number	Capacitance (pF)		
	"K" Series	From Below	To Above
KP8		0.6	8.0
KP10		0.6	10.0
KF8		0.6	8.0
KF10		0.6	10.0
KT8		0.6	8.0
KT10		0.6	10.0
KJ8		0.6	8.0
KJ10		0.6	10.0
KT8L		0.6	8.0
KT10L		0.6	10.0
KG8		0.6	8.0
KG10		0.6	10.0
KM8		0.6	8.0
KM10		0.6	10.0

Note: All bushing threads are .190"-64

IN	MM	IN	MM	IN	MM	IN	MM
0.015	0.38	0.067	1.70	0.160	4.06	0.260	6.60
0.030	0.76	0.070	1.78	0.180	4.57	0.270	6.86
0.036	0.91	0.080	2.03	0.190	4.83	0.280	7.11
0.040	1.02	0.093	2.36	0.200	5.08	0.300	7.62
0.045	1.14	0.110	2.79	0.230	5.84	0.590	14.99
0.060	1.52	0.140	3.56	0.240	6.10		
0.065	1.65	0.150	3.81	0.250	6.35		

Recommended Tuning Tool: TT-100 or TT-500

Air Dielectric Variable Trimmers



Description

- Concentric tubular design
- Torque mechanism insures low ESR and low dynamic noise resulting in high Q
- Available in PC, panel mount, vertical mount and surface mount terminations
- High Reliability testing available

Characteristics

- Rated voltage: 250 VDC (5300 series 500 VDC)
- Insulation resistance: $>10^6$ M Ω @ 500 VDC
- Contact resistance: $<.01$ Ω
- Operating temperature: -65°C to $+125^{\circ}\text{C}$
- Vibration: 60g, 10-2000 Hz
- Shock: 1500g, .5 milliseconds
- 574°F solder used in construction

Note: The use of a Johanson tuning tool is recommended. Improper screwdriver size will cause internal thread damage.

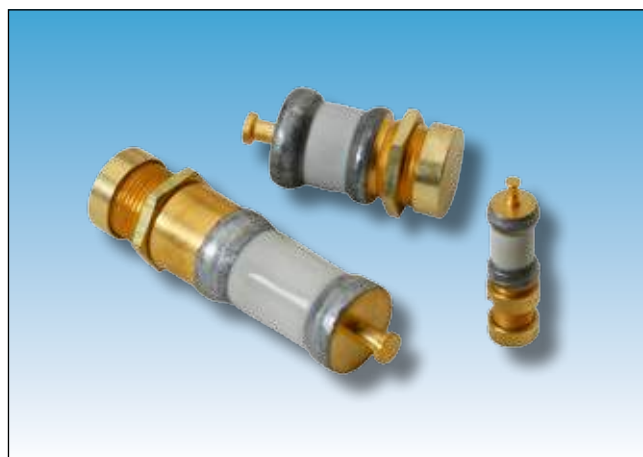

Applications

- RF amplifiers and oscillators
- Impedance matching
- Interstage coupling
- Filter tuning
- Crystal trimming

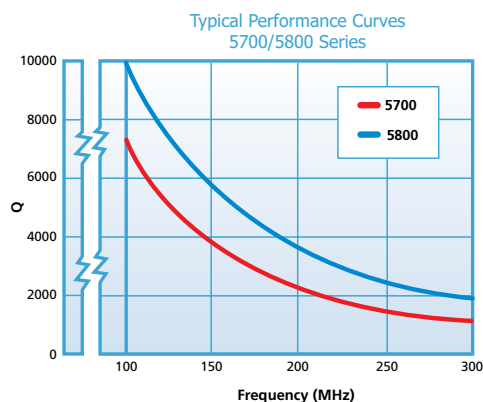
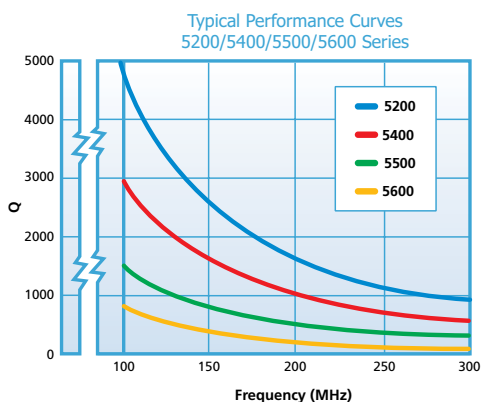

Tuning Tools

Trimmer Series	Diameter	Johanson Part Number	Diagram
5200 5300 5400 5500 5600 5700	.130	8777	
		8764	
5800	.078	8777	

Non-Magnetic Air Trimmers



Description

- Non-Magnetic construction
- High stability and Q
- 250 VDC working voltage
- Utilizes self-locking constant torque drive mechanism

Recommended Tuning Tool

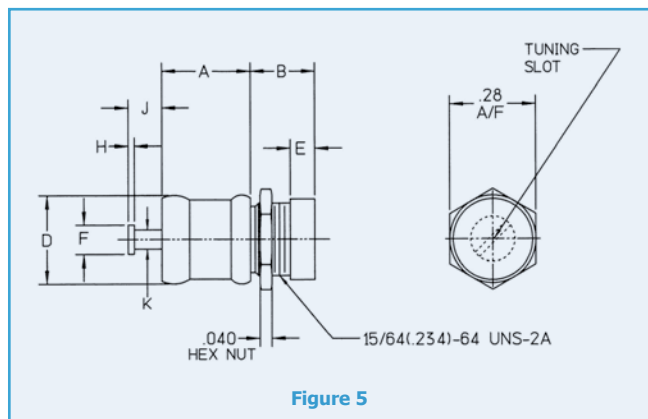
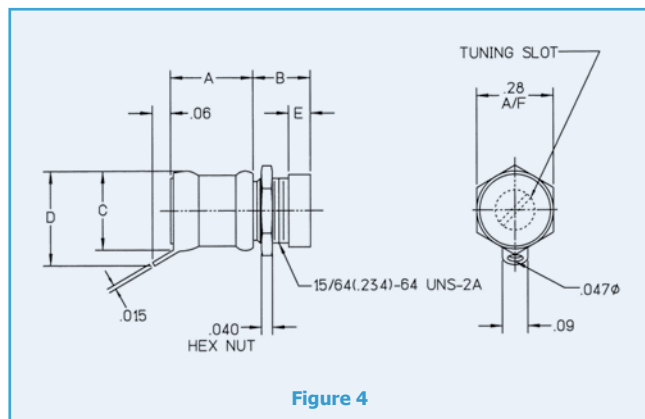
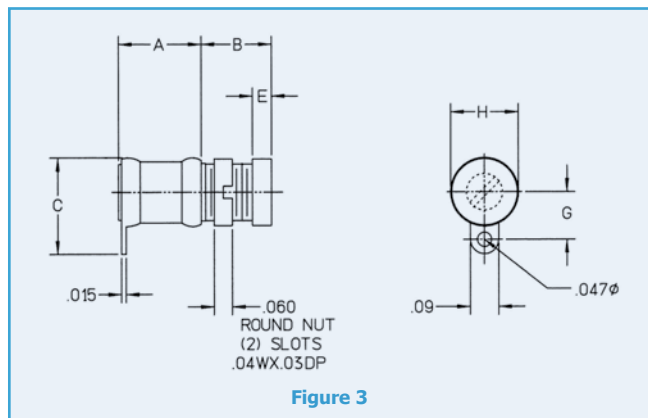
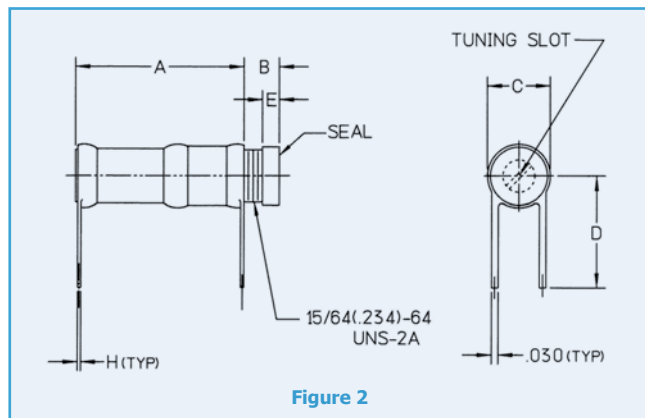
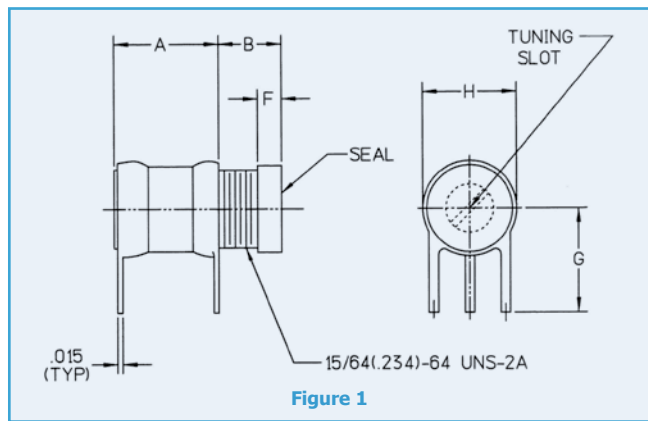
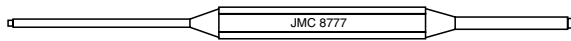

* 5862 & 5762 are supplied with a round nut instead of a hexagon.

Part Number	Cap Range (pF)	Min. Q @ 100 MHz	Dimensions								Fig.
			A	B	C	D	E	F	G	(UNS-2A)	
5862	0.4 to 3.5	>10000	0.27	0.225	.160 .150	-	0.06	0.03	0.045	.120-80	5*
5760	0.6 to 6.0	>10000	0.27	0.21	.235	-	0.06	-	-	.190-64	3
5761			0.29	0.19	.215	0.22	-	-	-		1
5762			0.27	0.21	-	0.04	0.06	-	-		5*
5240	0.8 to 10.0	>4000	0.30	0.21	.295	0.35	-	-	-	.234-64	4
5241			0.32	0.19	.275	0.31	0.08	-	-		1
5242			0.29	0.21	-	0.06	0.09	-	-		5
5640	1.0 to 30.0	>800	0.68	0.25	.295	0.35	-	-	-	.234-64	4
5641			0.76	0.16	.275	0.50	0.08	-	-		2
5642			0.68	0.25	-	0.06	0.09	-	-		5

Dimensions (inches)

Note: All Air Trimmers are available with or without hardware. Hardware may be purchased separately.

PTFE Trimmers - A1 Series

The Voltronics A1 Series of high reliability solid dielectric trimmer capacitors is an ideal economical replacement for conventional miniature air and sapphire dielectric trimmers and assures no intermittent noiseless performance.

High reliability solid dielectric, positive tuning stops and up to 13 full turns of linear tuning make the A1 Series an outstanding performer: 40 psi sealed, high voltage and non-magnetic versions are readily available.

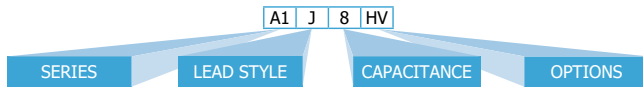

Options

The "HV" Option - high voltage applications: Add "HV" to the part number, i.e., A1T4HV.

Specifications are as follows:

Capacitance	DC Volts Working	DC Volts Withstanding
4pF	1,000	2,000
8pF	500	1,000
11pF	500	1,000

Non-Magnetic Option:

Most parts shown can be ordered as non-magnetic. Add "NM" to the part number, i.e., NMA1J8.

Sealed Option:

All parts shown can be ordered as 40 psi sealed. Add "S" to the part number, i.e., A1M4S.

Tape & Reel Options:

Consult Factory - M & J style only
Recommended Tuning Tool: TT-400



General Specifications	A1_4	A1_8	A1_12
Capacitance Range	0.5 to 4pF	0.5 to 8pF	0.6 to 11pF
DC Working Voltage	250	125	125
DC Withstanding Voltage	500	250	250
Self-Resonant Frequency*	2.3 GHz at 4pF	1.7 GHz at 8pF	1.2 GHz at 11pF
Number of Turns	7	7	13
Q (min) at 100 MHz @ Max. C*	4000	3000	2000
Temperature Coefficient	0±50 ppm/°C	0±100 ppm/°C	0±150 ppm/°C
Insulation Resistance @ 25° C	10 ⁶ MΩ		
Operating Temperature	-65°C to +125°C		
Tuning Torque	0.3 to 1.0 in - oz		
Shock	1,500g, 0.5 millisecs.		
Vibration	50g at 10 - 2000 Hz		

* Self-resonant frequency and Q are assured with no terminals on parts.

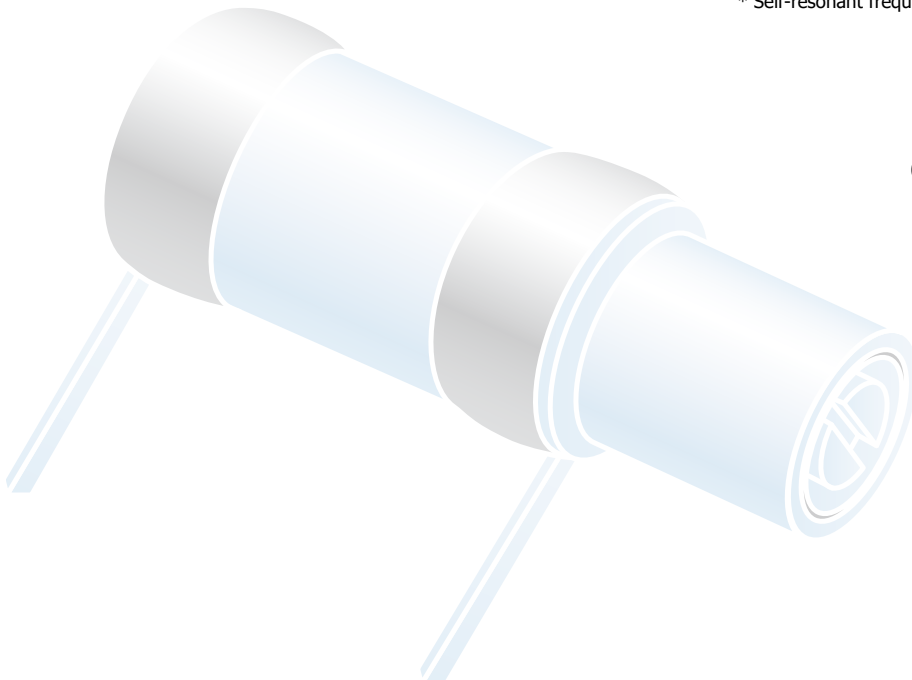
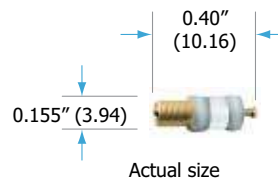

Miniature PTFE Trimmers - A4 Series

The Voltronics A4 Series unique design using minimal parts simplifies the manufacturing process to effect one of the most economical high performance trimmer capacitors available in the industry.

The Voltronics A4 Series also features a high reliability solid dielectric, positive tuning stops and up to 5 full turns of linear tuning in the shortest length of any similar trimmer capacitor. The Voltronics A4 is an ideal choice for tuning and impedance matching, high frequency and high power amplifier circuits.

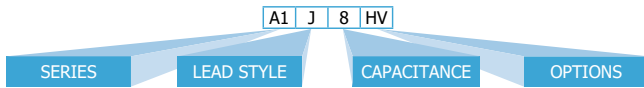

Options

The "HV" Option - high voltage applications:
Add "HV" to the part number, i.e., A1T4HV.

Specifications are as follows:

Part No.	DC Volts Working	DC Volts Withstanding
A4_3 HV	500	1,000
A4_5 HV	500	1,000

Non-Magnetic Option -

All parts can be ordered as non-magnetic. Add "NM" to the part number, i.e. NMA4J3

Tape and Reel Options: Consult Factory - M style only

SD Option -

For applications requiring high reliability but lower voltage

Part No.	Working Voltage	Withstanding Voltage
K_1SD	250	500
A or K_4SD	250	500
A_25SD	125	250
A_30*	250	500
A_40SD	250	500
A_55SD	125	250

Note: A_30 not available in high voltage configuration

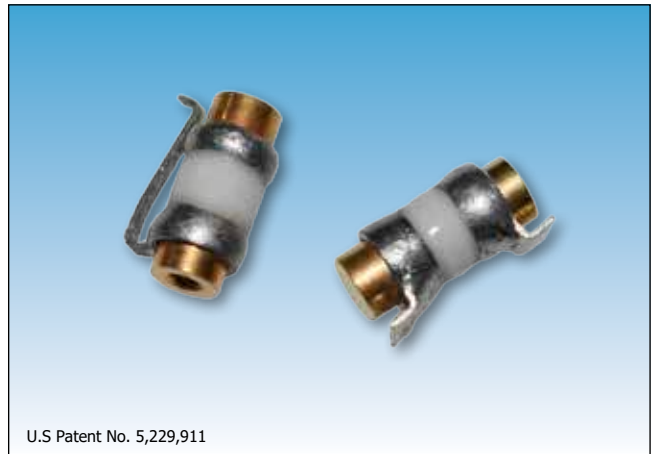
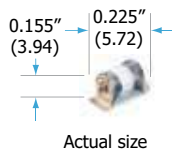

General Specifications	A4_3	A4_5
Capacitance	0.45 to 3pF	0.6 to 5pF
DC Working Voltage	125	125
DC Withstanding Voltage	250	250
Self-Resonant Frequency*	3 GHz at 3pF	1.8 GHz at 5pF
Number of Turns	4	5
Q (min) at 100 MHz @ Max. C*	3000	2000
Temperature Coefficient	0±100 ppm/°C	0±300 ppm/°C
Insulation Resistance @ 25° C	10 ⁶ MΩ	
Operating Temperature	-65°C to +125°C	
Tuning Torque	0.3 to 1.0 in - oz	
Shock	1,500g, 0.5 millisecs.	
Vibration	50g at 10 - 2000 Hz	

* Self-resonant frequency and Q are assured with no terminals on parts.

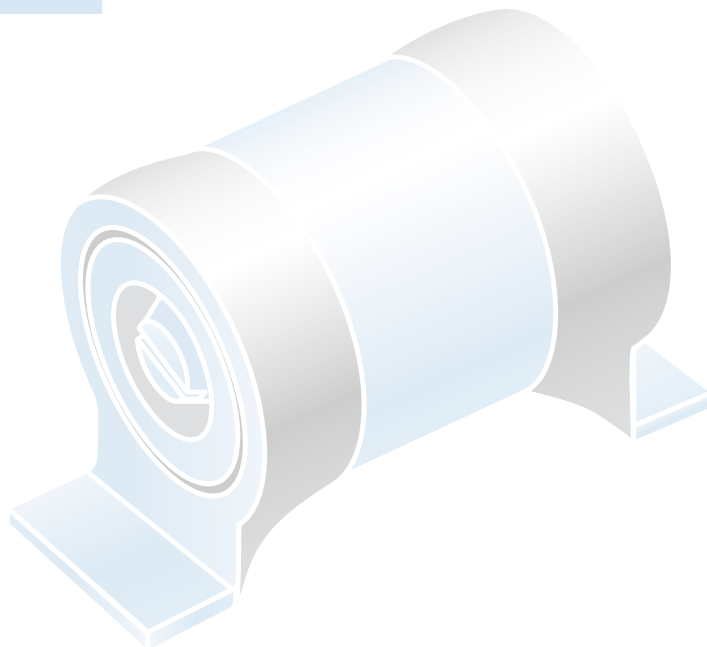

The only internally sealed High Voltage PTFE trimmer

Voltronics' concentric ring PTFE dielectric trimmer capacitors are designed for use at frequencies up to 1.5 GHz. They are ideal for HIGH VOLTAGE applications. The solid internal PTFE dielectric prevents ionization, a major advantage in space, high altitude and high voltage applications. The unique internal O-ring seal makes wave soldering and vapor degreasing possible without the need to attach a separate cap.

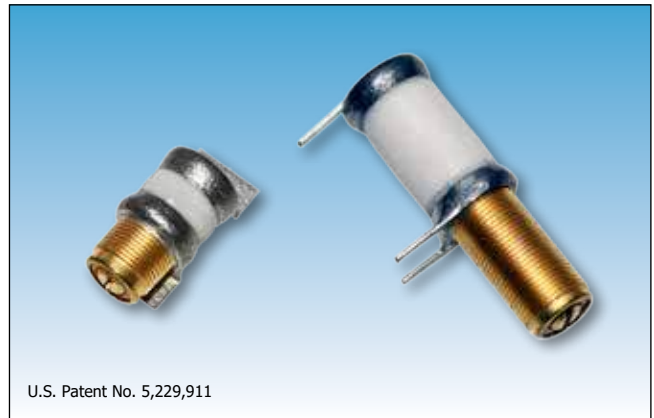
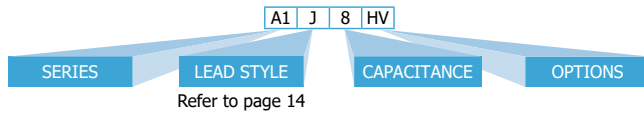

General specifications	A_4HV	A_10 HV	A_15 HV	A_25 HV
Capacitance Range	1 to 4pF	1 to 10pF	1 to 16pF	1 to 23pF
DC Working	1000	1000	1000	750
DC Withstanding	2000	2000	2000	1500
Q (min) at 100MHz @ Max. C*	2000	2000	2000	2000
Temperature Coefficient - 0±100ppm/°C	-50±50 ppm/°C	-50±50 ppm/°C	50±50 ppm/°C	-50±50 ppm/°C
Insulation Resistance @ 25°C	10 ⁶ MΩ	10 ⁶ MΩ	10 ⁶ MΩ	10 ⁶ MΩ
Seal	40 pounds/in ²	40 pounds/in ²	40 pounds/in ²	40 pounds/in ²
Operating Temperature	-65°C to +125°C	-65°C to +125°C	-65°C to +125°C	-65°C to +125°C
Rotational Life	600 Turns	600 Turns	600 Turns	600 Turns
Tuning Torque	.05 to 5.0 in-oz	.05 to 5.0 in-oz	.05 to 5.0 in-oz	.05 to 5.0 in-oz
Shock	1,500g, 0.5 millisecons.	1,500g, 0.5 millisecons.	1,500g, 0.5 millisecons.	1,500g, 0.5 millisecons.
Vibration	50g at 10-2000 Hz	50g at 10-2000 Hz	50g at 10-2000 Hz	50g at 10-2000 Hz

* Self-resonant frequency and Q are assured with no terminals on parts.

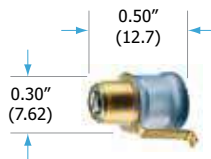

Extended Range

General specifications	A_40HV	A_55HV
Capacitance Range	1.5 to 40pF	1.5 to 55pF
Q (min) at 100MHz @ Max. C*	2000	-
Q (min) at 75MHz @ Max. C*	-	780
Temperature Coefficient	0±100 ppm/°C	0±100 ppm/°C
Insulation Resistance @ 25°C	10 ⁶ MΩ	10 ⁶ MΩ
Seal	40 pounds/in ²	40 pounds/in ²
Operating Temperature	-65°C to +125°C	-65°C to +125°C
Rotational Life	600 Turns	600 Turns
Tuning Torque	.05 to 5.0 in-oz	.05 to 5.0 in-oz
Shock	1,500g, 0.5 millisecons.	1,500g, 0.5 millisecons.
Vibration	50g at 10-2000 Hz	50g at 10-2000 Hz
DC Working Voltage	1000	600
DC Withstanding Voltage	2000	1200

* Self-resonant frequency and Q are assured with no terminals on parts.

Extended metal shaft option: Add "E" to Part Number, i.e., AT40SDE

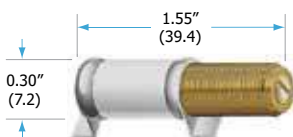

Other features include:

- Ten or 29 linear turns
- Internal stops
- Extreme stability under shock & vibration
- Screw head does not move in and out
- Extended shaft option of metal or plastic
- Long life with no dynamic tuning noise

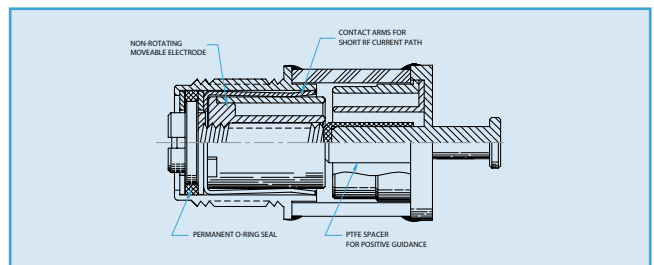

Options

Non-Magnetic Option: All parts can be ordered as non-magnetic. Add "NM" to the part number, i.e. NMAT25HV, NMKP10HV.

Extended Shaft Options:

Add "E" to the part number, i.e. AT10HVE.

Extended Plastic Shaft Options:

Add "EI" to the part number, i.e. EF10HVEI.

SD Option:

For applications requiring high reliability but lower voltage.

Part No.	Working Voltage	Withstanding Voltage
K_1SD	250	500
A or K_4SD	250	500
A_25SD	125	250
A_30*	250	500
A_40SD	250	500
A_55SD	125	250

Note: A_30 not available in high voltage configuration

PTFE Trimmers - K_HV Series



General specifications	K_HV
Q at 1GHz at maximum rated C*	780 (1pF)
Q at 100MHz at maximum rated C*	2000 (4 & 9pF)
Temperature Coefficient	50±50ppm/°C
Insulation Resistance	10 ⁶ MΩ
Seal	40 pounds/in ²
Operating Temperature	-65°C to +125°C
Rotational Life	600 turns
Torque	0.5-5.0 in-oz
Vibration	50g, 10-2000 Hz
Shock	1500g, 0.5 milliseconds.
Drawing tolerances where not specified	XXX ± .005 XX ± .016

* Self-resonant frequency and Q are measured with no terminals on parts.

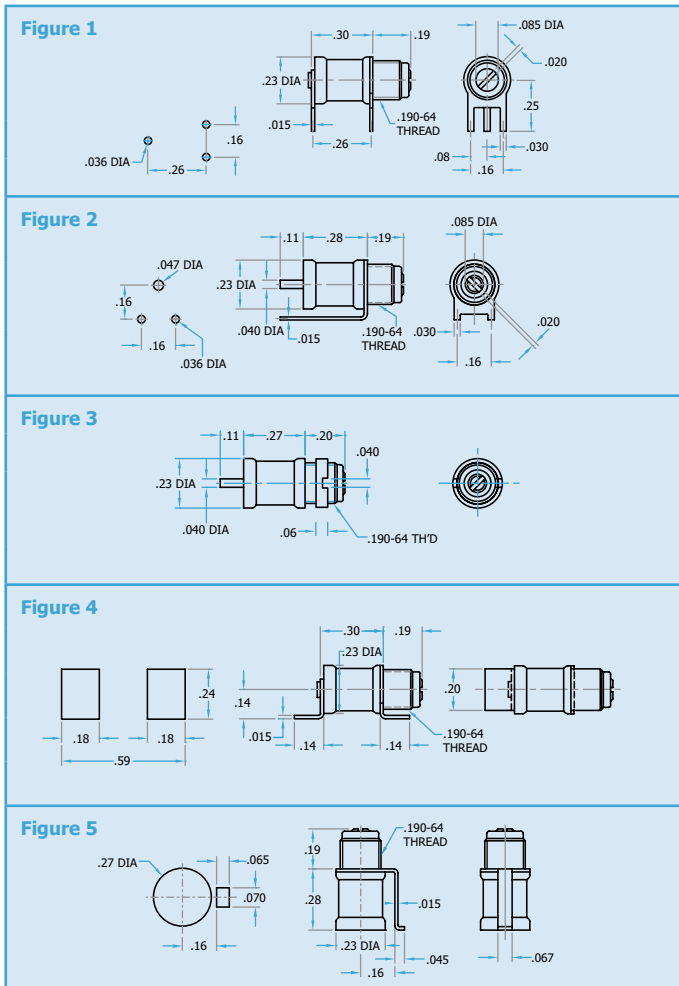

Note: All bushing threads are .190"-64

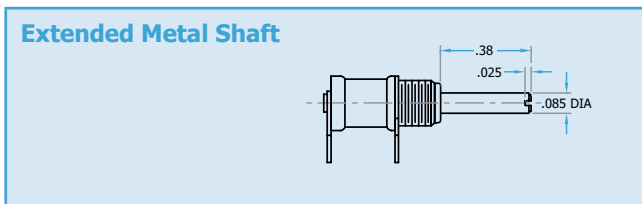

Add "E" to Part Number, i.e., KP10HVE.

Part Number "K" Series	DC Working Voltage	DC Withstanding Voltage	Capacitance (pF)	
			From Below	To Above
KP1HV	1000	2000	0.2	1
KP1SD	250	500	0.2	1
KP4HV	1000	2000	0.6	4
KP4SD	250	500	0.6	4
KP10HV	1000	2000	1.0	9
KF4HV	1000	2000	0.6	4
KF4SD	250	500	0.6	4
KF10HV	1000	2000	1.0	9
KT1HV	1000	2000	0.2	1
KT1SD	250	500	0.2	1
KT4HV	1000	2000	0.6	4
KT4SD	250	500	0.6	4
KT10HV	1000	2000	1.0	9
KJ1HV	1000	2000	0.2	1
KJ1SD	250	500	0.2	1
KJ4HV	1000	2000	0.6	4
KJ4SD	250	500	0.6	4
KJ10HV	1000	2000	1.0	9
KM4HV	1000	2000	0.6	4
KM4SD	250	500	0.6	4
KM10HV	1000	2000	1.0	9

IN	MM	IN	MM	IN	MM	IN	MM
0.015	0.38	0.067	1.70	0.160	4.06	0.280	7.11
0.025	0.63	0.080	2.03	0.190	4.83	0.290	7.37
0.030	0.76	0.085	2.16	0.200	5.08	0.300	7.62
0.036	0.91	0.093	2.36	0.230	5.84	0.380	9.65
0.040	1.02	0.110	2.79	0.240	6.10	0.470	11.94
0.045	1.14	0.140	3.56	0.264	6.71		
0.060	1.52	0.150	3.81	0.270	6.86		

Recommended Tuning Tool: TT-100 or TT-500

Very High Voltage PTFE Trimmers

This range of Voltronics trimmer capacitors provides a further extension in voltage rating to the HV range. Working voltage is 2kV and dielectric withstand voltage is 4kV. The solid internal PTFE dielectric prevents ionization, a major advantage in space, high altitude and high voltage applications. The unique internal O-ring seal makes wave soldering and vapor degreasing possible without the need to attach a separate cap.

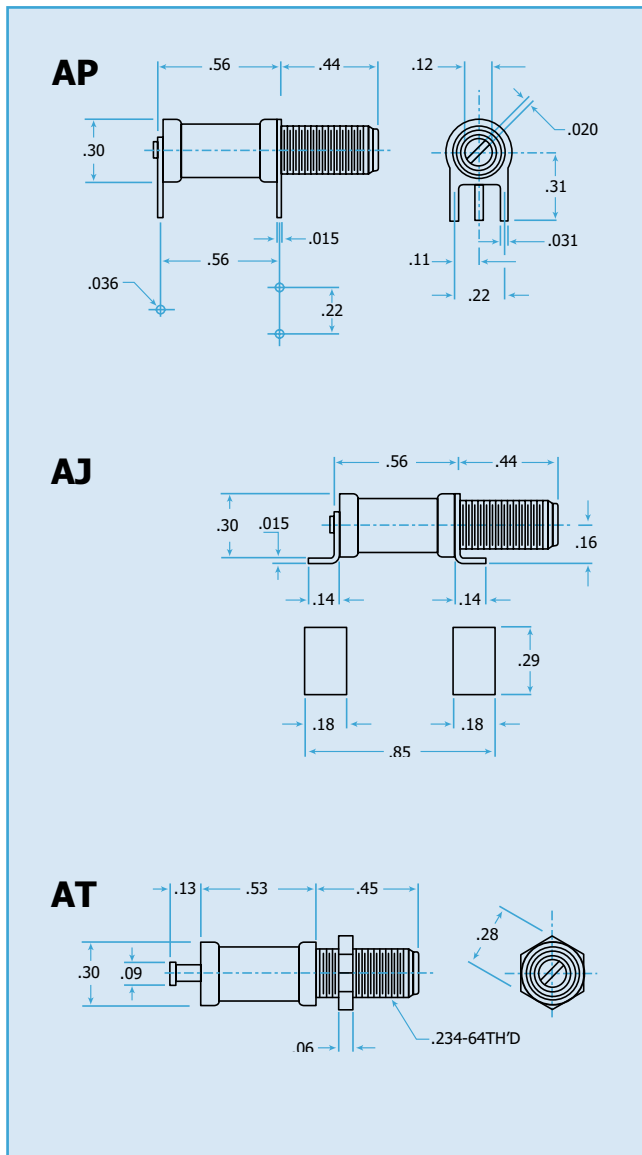
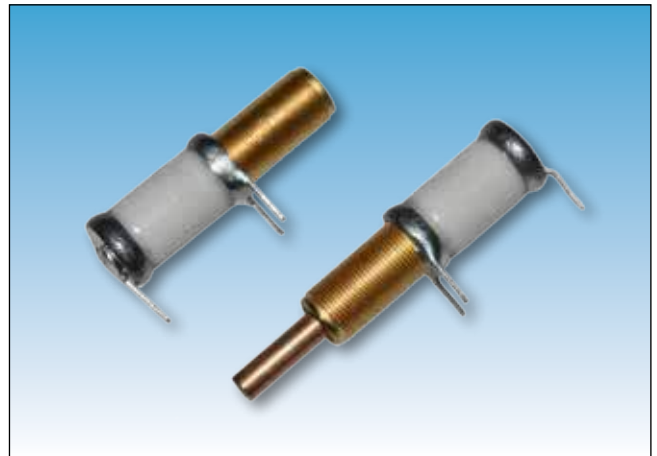

General Specifications	A_10-4	A_20-4
Capacitance Range	0.8 to 10pF	0.8 to 20pF
DC Working Voltage	2000	2000
DC Withstanding Voltage	4000	4000
Self-Resonant Frequency*	4.25 GHz at 2pF	3 GHz at 3pF
Q (min) at 100 MHz @ Max. C*	3000	3000
Temperature Coefficient	0±100 ppm/°C	0±100 ppm/°C
Insulation Resistance @ 25°C	10 ⁶ MΩ	10 ⁶ MΩ
Operating Temperature	-65°C to +125°C	-65°C to +125°C
Tuning Torque	0.5 to 5.0 in-oz	0.5 to 5.0 in-oz
Shock	1500g, 0.5 millisees.	1500g, 0.5 millisees.
Vibration	50g at 10-2000 Hz	50g at 10-2000 Hz
Drawing Tolerances where not specified	XXX ± .005 XX ± .016	XXX ± .005 XX ± .016

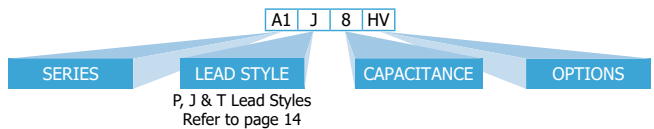

Options:

Extended metal shaft.
Add 'E' to the part number i.e. AT10-4E

Dimensions

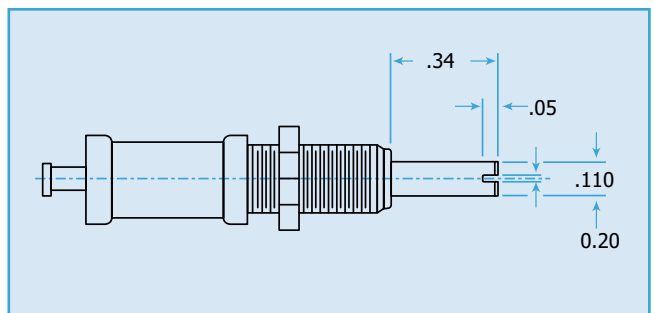

Note: For Non-Magnetic parts add 'NM' to part number, i.e. NMAT10-4

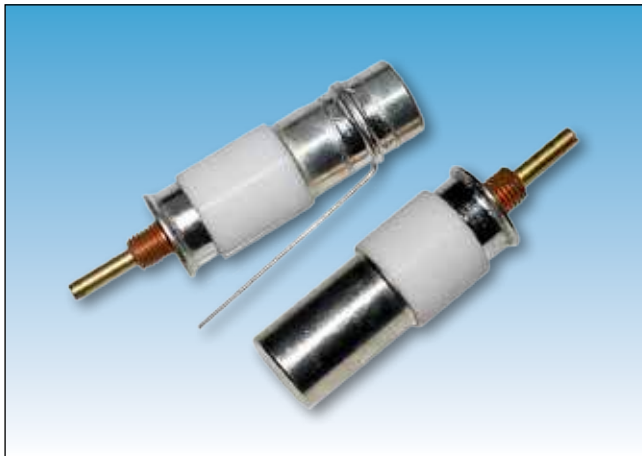

4kV to 10kV

Voltronics NMNT Series of PTFE trimmers are designed for applications requiring greater capacitance and voltage ratings than the popular smaller trimmers but without the large size and expense of vacuum capacitors.

The NMNT Series offers:

- High voltage
- Non-rotating piston, long life and no tuning noise
- Extremely stable under shock and vibration
- Screw head does not move in and out

Proven RF performance and power handling these high performance trimmer capacitors are utilized in MRI body coils, NMR equipment and RF power transfer applications.

Part Number	DC Working Voltage	DC Withstanding Voltage	Capacitance (pF) <	Capacitance (pF) >	"A" Dim ±.06	"B" Dim ±.06
NMNT2-20	10000	20000	1.0	2.0	1.205	1.125
NMNT5-8	4000	8000	1.0	5.0	1.13	0.31
NMNT5-18	8750	17500	1.0	5.0	2.0	0.75
NMNT10-6	3000	6000	1.0	10.0	1.15	0.38
NMNT10-12	6000	12000	2.0	10.0	1.83	.063
NMNT15	2000	4000	1.0	15.0	1.69	0.31
NMNT23-6	3000	6000	3.0	23.0	1.70	0.38
NMNT23-12	6000	12000	3.0	23.0	1.845	0.63
NMNT25-6	3000	6000	5.0	25.0	1.62	.063
NMNT25-15	7500	15000	7.0	25.0	1.77	1.13
NMNT30	3000	6000	4.0	30.0	2.25	1.50
NMNT50	4500	9000	5.0	50.0	2.25	1.50
NMNT70-6	3000	6000	2.5	70.0	3.00	0.70
NMNT70-15	7500	15000	6.5	70.0	3.25	1.63
NMNT85	3000	6000	5.0	85.0	3.25	1.50
NMNT100-4	2500	3600	2.0	95.0	4.25	0.31

Note: Preferred parts. Others available but may be subject to an increased MOQ.

Dimensions

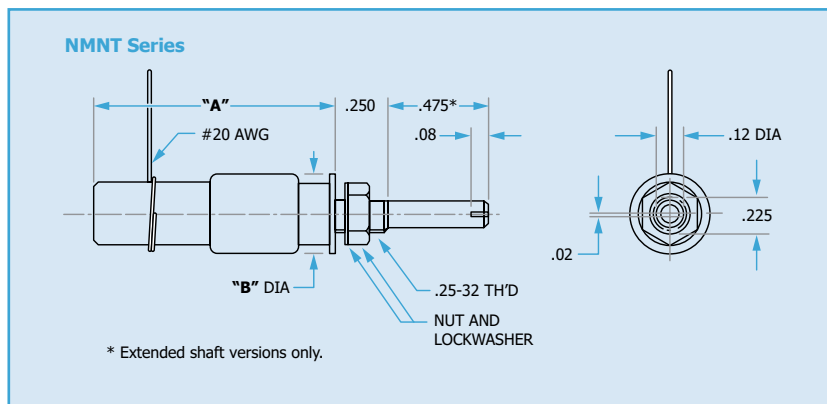

High Voltage Trimmers



Characteristics

- Rated voltage:
1250 VDC - test voltage 2500 VDC (52H02)
1000 VDC - test voltage 2000 VDC (55H01) (55H02) (80H85)
- $Q > 1400 @ 195 \text{ MHz}$ (52H02)
- $Q > 1000 @ 175 \text{ MHz}$ (55H01) (55H02) (80H85)
- Insulation resistance: $> 10^6 \text{ M}\Omega$
- Operating temperature range: -65°C to $+125^\circ\text{C}$
- Torque: 1 to 10 oz. in.
- Contact resistance: $< .01 \Omega$

Recommended Tuning Tool

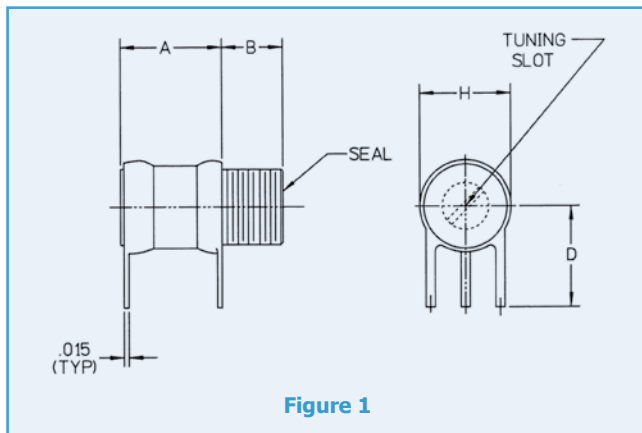
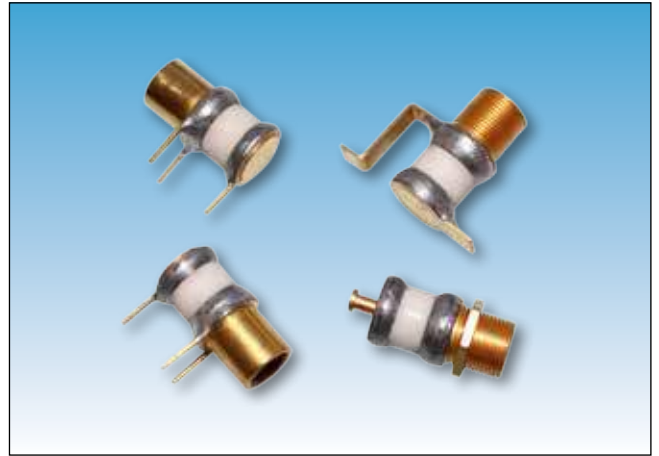
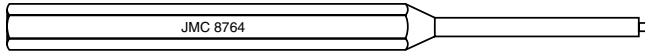

Figure 1

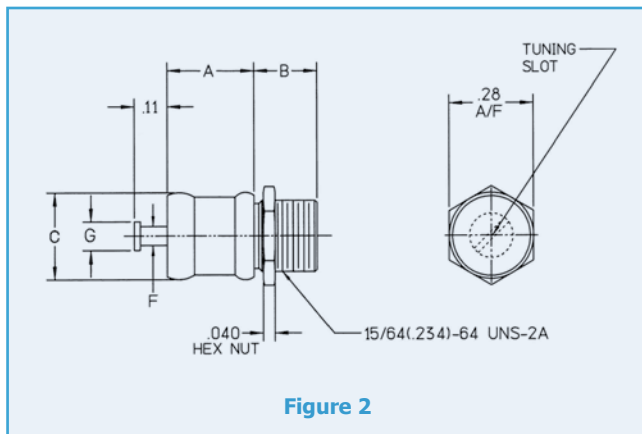

Figure 2

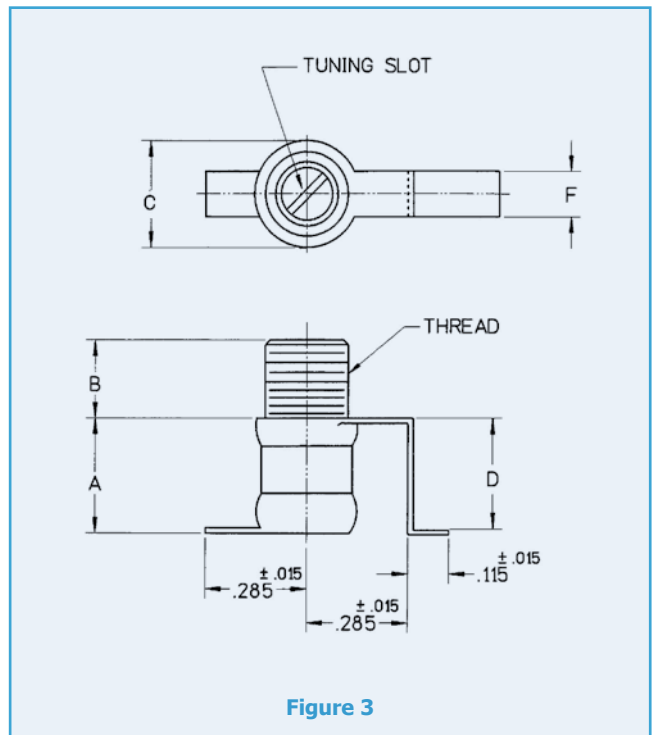

Figure 3

Part Number	Cap Range (pF)	Min. Q @ 175 MHz	Dimensions							Fig.	
			A	B	C	D	E	F	G		
52H01 52H02	1.5 to 10.0	$> 1400^*$	0.31	0.22	.295 .275	0.31 -	-	-	0.06	0.09	1 2
55H01	1.5 to 19.0	> 1000	0.31	0.22	.295 .275	0.31	-	-	-	-	1
55H02	1.5 to 19.0	> 1000	0.31	0.22	.295 .275	-	-	-	0.06	0.09	2
80H85	1.5 to 19.0	> 1000	0.31	0.22	.295 .275	0.32	-	-	0.125	-	2

Notes: Dimensions (inches). *Q @ 195MHz.

Description

- Sapphire dielectric
- Ceramic dielectric
- Zirconia High K dielectric
- High Q
- 500 VDC working voltage
- Select part numbers available on tape and reel
- Utilizes the same constant torque drive mechanism as Johanson air capacitors and tuning elements

Characteristics

- Rated voltage: 500 VDC
- Insulation resistance: $>10^6$ M Ω @ 500 VDC
- Rotational life exceeds Mil-C-14409
- Contact resistance: $<.01$ V
- Operating temperature: -65°C to $+125^{\circ}\text{C}$
- Self resonant frequency: >12 GHz
- Vibration: 60g, 10-2000 Hz
- Shock: 100g, 6 milliseconds

Applications

- Impedance matching
- Crystal trimming
- Interstage coupling
- Base station amplifier



JMC Drive Tuning Tool 8762

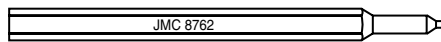

JMC Drive Tuning Tool 8766

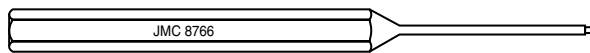

Note: The use of a Johanson tuning tool is recommended. Improper screwdriver size will cause internal thread damage.

Seal Caps

Type	Part No.	Cap type	Material
17273	P4446-2	"Poke-Thru" Seal Cap	Teflon®
27260 Thru 27265	P4445-1	Standard Seal Cap	Teflon®
27270 Thru 27295	P4445	Standard Seal Cap	Teflon®
27260 Thru 27265	P4446-1	"Poke-Thru" Seal Cap	Teflon®
27270 Thru 27295	P4446	"Poke-Thru" Seal Cap	Teflon®
47273 Thru 47285	P4446-2	"Poke-Thru" Seal Cap	Teflon®
57263	P4446-1	"Poke-Thru" Seal Cap	Teflon®

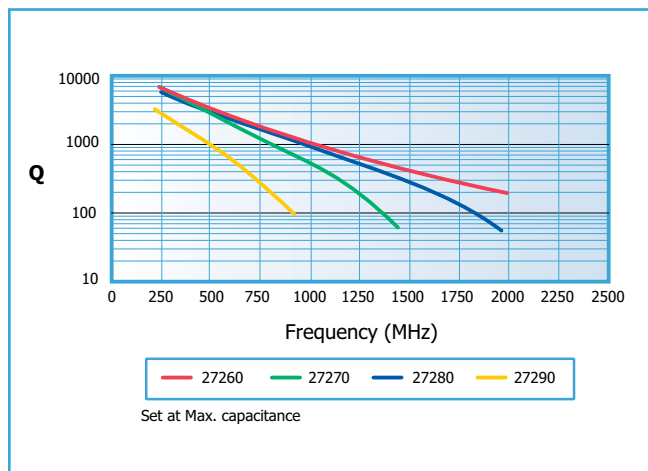



Part No.	Capacitance Range (pF)	Number of Turns	Working Voltage (VDC)	Dielectric	Tuning Torque (oz in)	Q @ 250 MHz	Page Number
17273	0.6 to 4.5	>8	500	Alumina	0.2 to 2	>2000	31
27261	0.3 to 1.2	>5	500	Sapphire	0.1 to 1	>5000	32
27261SL							31
27263							
27264							
27265							
27271	0.6 to 4.5	>8	500	Sapphire	0.2 to 2	>3000	32
27271SL							31
27273							
27274							
27275							
27281	0.4 to 2.5	>4	500	Sapphire	0.2 to 2	>4000	32
27281S L							31
27283							
27284							
27285							
27291	0.8 to 8.0	>16	500	Sapphire	0.2 to 2	>*3000	32
27291SL							31
27293							
27294							
27295							
47273	0.6 to 4.5	>8	500	Alumina	0.2 to 2	>3000	31
47473	2.0 to 6.0	>6				>1500	
47483	0.3 to 2.3	>4				>2000	
47285-3	0.4 to 2.5	>4				>**3000	32
57273	0.8 to 8.0	>8	500	Zirconia	0.2 to 2	>*2000	32
57285-3	0.8 to 4.5	>4				>**1000	32

*Q @ 100 MHz **@ 200 MHz

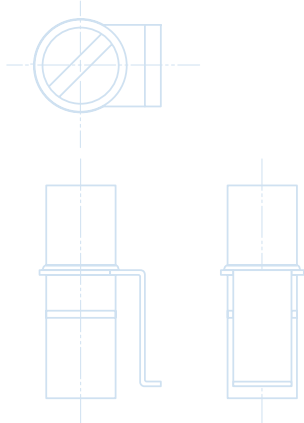

Part No.	Units/Reel	Carrier Tape
27273-3R5	400	24mm
27283-3R10	750	16mm
47275-1R11	500	32mm
47273-11R5	400	24mm
47273R5	400	24mm
47483R10	750	16mm
572733R5	400	24mm

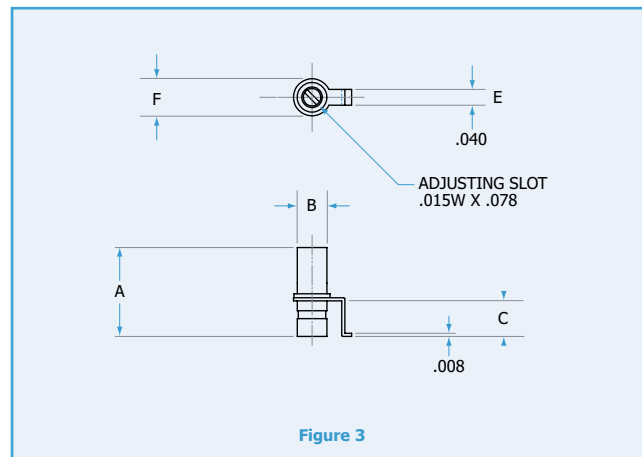
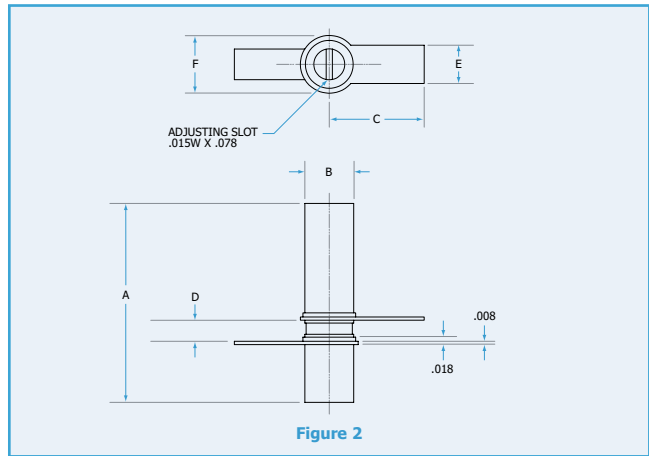
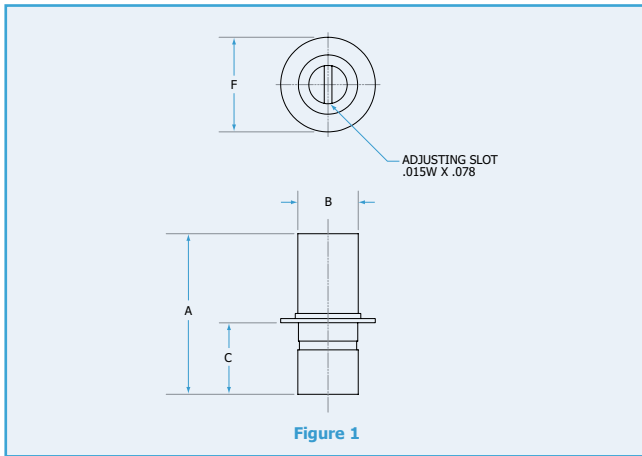

Cap Range	Part No.	A	B	C	D	E	F	Fig.
0.3 to 1.2	27263	0.225	0.075	0.09	-	0.040	0.094	3
0.3 to 2.3	47483	0.230	0.118	0.09	-	0.040	0.15	3
0.4 to 2.5	27273	0.314	0.118	0.09	-	0.040	0.14	3
0.6 to 4.5	17273	0.330	0.118	0.16	-	0.040	0.15	3
	47273	0.330	0.118	0.16	-	0.040	0.15	3
	27283	0.314	0.118	0.16	-	0.040	0.14	3
0.9 to 4.5	57283	0.230	0.118	0.09	-	0.093	0.15	3
0.8 to 8.0	27273	0.330	0.118	0.16	-	0.093	0.15	3
0.8 to 8.0	27293	0.480	0.118	0.25	-	0.040	0.14	3
2.0 to 6.0	47473	0.330	0.118	0.16	-	0.040	0.15	3
0.3 to 1.2	27264	0.225	0.075	0.23	0.056	0.040	0.094	2
0.4 to 2.5	27274	0.225	0.118	0.23	0.056	0.093	0.14	2
0.6 to 4.5	27284	0.314	0.118	0.23	0.060	0.093	0.14	2
0.8 to 8.0	27294	0.480	0.118	0.23	0.051	0.093	0.14	2
0.3 to 1.2	27265	0.225	0.075	0.078	-	-	0.142	1
0.4 to 2.5	27275	0.225	0.118	0.09	-	-	0.185	1
0.6 to 4.5	27285	0.314	0.118	0.16	-	-	0.185	1
0.8 to 8.0	27295	0.480	0.118	0.25	-	-	0.185	1

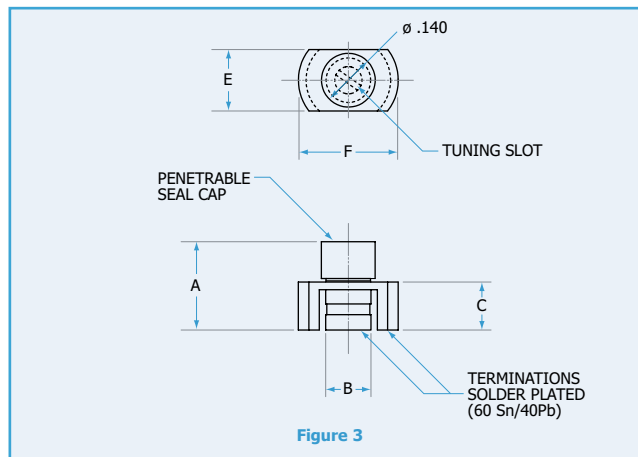
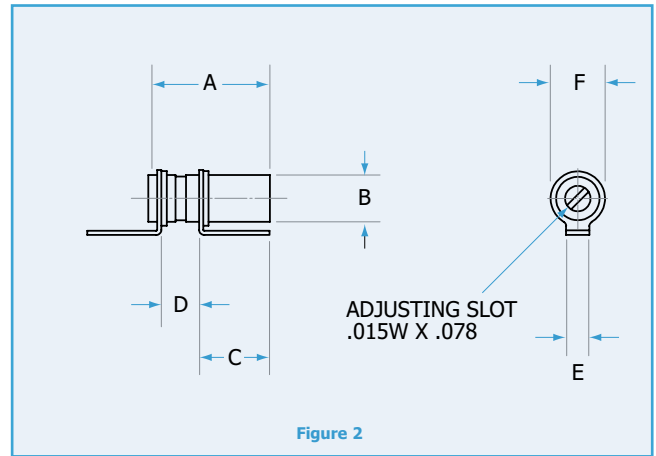
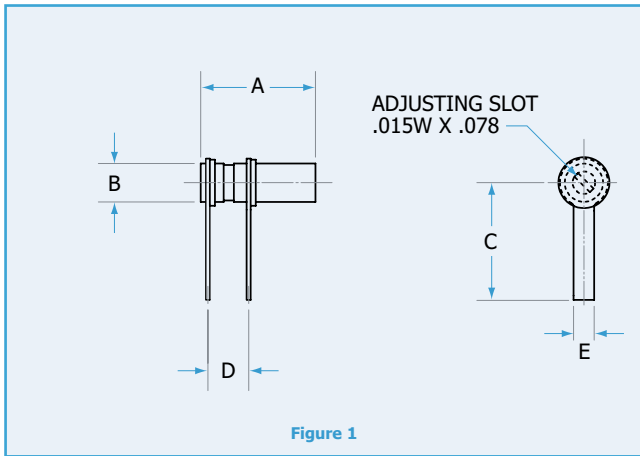

Cap Range	Part No.	A	B	C	D	E	F	G	Fig.
0.3 to 1.2	27261	0.225	0.075	0.23	0.08	0.04	0.094	-	1
0.4 to 2.5	47281	0.225	0.118	0.23	0.08	0.04	0.14	-	1
0.6 to 4.5	27271	0.314	0.118	0.23	0.13	0.04	0.14	-	1
0.8 to 8.0	27291	0.480	0.118	0.23	0.25	0.04	0.14	-	1
0.3 to 1.2	27261SL	0.225	0.075	0.18	0.07	0.04	0.094	-	2
0.4 to 2.5	27281SL	0.225	0.118	0.16	0.07	0.04	0.14	-	2
0.6 to 4.5	27271SL	0.314	0.118	0.16	0.12	0.04	0.14	-	2
0.8 to 8.0	27292SL	0.480	0.118	0.16	0.24	0.04	0.14	-	2
0.4 to 2.5	47285-3	0.230	0.118	0.125	-	0.160	0.260	-	3
0.8 to 4.5	57285-3	0.230	0.118	0.125	-	0.160	0.260	-	3

Non-Magnetic Sapphire Trimmer - V9000



The V9000 trimmer capacitor is a unique design: truly sub miniature at just 0.64" (16.3mm) in length but offers the highest working voltage rating of 2kV and capacitance value, up to 12pF, available in its size.

Using a Sapphire dielectric, for its ideal dielectric constant, it is extremely stable, is chemically inert, moisture resistant and mechanically strong. Recently launched, additional features are still under development, contact Voltronics for our usual custom modifications and adaptations.



General specifications	
Capacitance Range	1.0pF to 12.0pF Typical
DC Working Voltage @ 12.0pF	2000V
DC Withstanding Voltage @ 12.0pF	3000V
Q Factor @ 100 MHz & 12.0 pF	3000 Min
Insulation Resistance	105 MΩ @ 25°C
Temperature Coefficient	500 ± 200 ppm/°C
Mechanical specifications	
Tuning Torque	0.5 in oz to 3.0 in oz
Rotational Life	600 Turns Min
Construction	Non-Magnetic
Environmental	
Operating Temperature	-55°C to +125°C
RoHS Compliant	

Dimensions

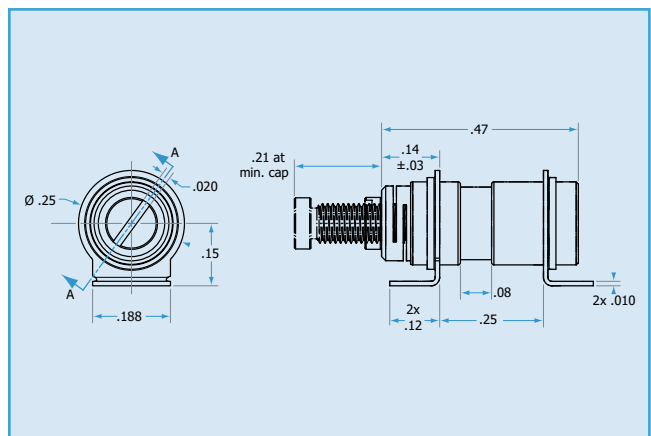

Part No.	DC Working Voltage	DC Withstanding Voltage	Capacitance (pF) <	Capacitance (pF) >
V9000	2000V	3000V	1	12

V9000 cutaway



Solder pad layout

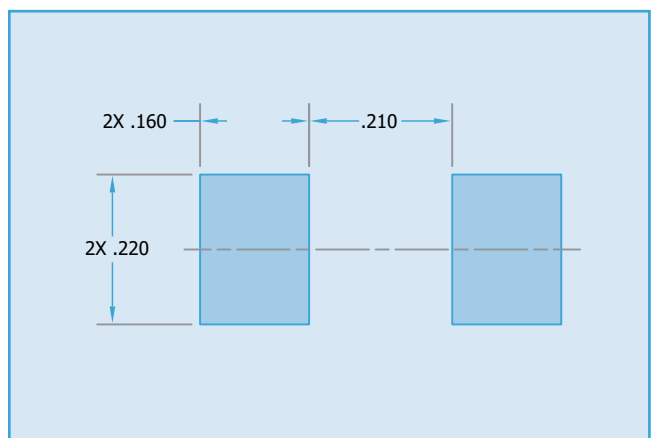

Design Features

The unique Voltronics non-rotating precision trimmer capacitor design offers the following advantages over conventional rotating types:

- Linear tuning with no reversals
- A true high frequency device with high Q's, low RF losses, low constant inductance and high self-resonant frequencies
- A superior seal because the screw head and O-ring do not move in and out
- Greater life - 10,000 cycles minimum
- Much smaller sealed MIL sizes
- Ability to provide extended metal or plastic shafts

Dielectric

The dielectric is a tube which has been precision drawn in a vacuum so that its inner diameter is held within $\pm 0.0002''$. The choices are:

- 1. Annular Band Glass:** A solid tube of a specially selected formulation of glass which is metallized on the outside.
- 2. Embedded Band Glass:** Two tubes of glass fired together with a metallized silver band embedded between them. The inner tube is only 0.005" thick to provide much higher capacitance values.
- 3. Quartz:** A pure-grade silicon oxide offering higher Q and voltage ratings in each size with the trade-off of lower capacitance and higher cost.

General Specifications

(where not specified on detail pages)

Piston Action

Non-rotating.

Blind Hole Tuning

Screw head does not move in and out.

Linearity

$\pm 1\%$ with no capacitance reversals.

Resolution

#2-72 tuning screw for fine tuning - approximate pico-farads per turn in active tuning range:

- | | |
|--------------------------------|-------------|
| 1. Annular band glass | 0.6 to 0.8 |
| 2. Embedded band glass | 2.3 to 3.0 |
| 3. Quartz | 0.3 to 0.36 |
| 4. "H" Series high range glass | 3.9 to 4.2 |

Insulation Resistance

Annular band glass and quartz:
 10^6 M Ω at 25°C to 125°C

Embedded band glass:
 10^6 M Ω at 25°C
 10^5 M Ω at 125°C

Tuning Torque

1 to 8 inch ounces.

Life

Over 10,000 cycles.

Temperature Coefficient

Annular Band Glass: ± 50 ppm/°C
 Embedded Band Glass: ± 150 ppm/°C
 Quartz: 0 to +50 ppm/°C

Dielectric Withstanding Voltage

Twice DC working voltage (listed with each part).

Capacitance Tuning Range

From below minimum to above maximum value listed for each part. Capacitance measured at 1 MHz on Boonton Electronics 7600 bridge using Voltronics V1265 guarded test jig. AM measurements taken with leads perpendicular to unit regardless of final configuration.

Temperature Range

All glass dielectrics: -55°C to 125°C
 Quartz dielectric: -55°C to 150°C

Other Specifications

All other specifications including vibration, shock, moisture and seal (where applicable) per MIL-C-14409D.

Drawing Tolerances (where not specified)

Decimal: XXX $\pm 0.016''$
 XX $\pm 0.03''$

Quality Factor

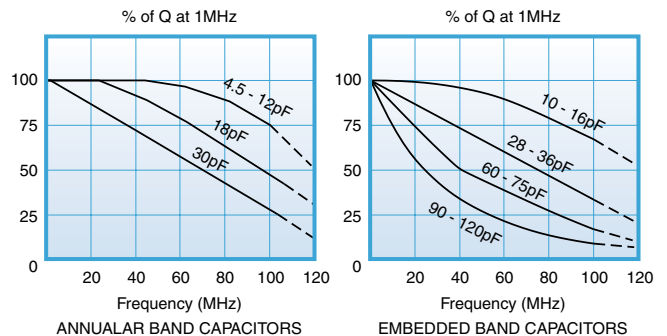

Recommended Tuning Tools: TT-100 or TT-600

Smallest Sealed Glass Trimmers - S Series



The PC17 styles are the only vertically mounted glass trimmers in MIL-C-14409D.

Voltronics "S" Series are up to 40% shorter with 25% more range than any other sealed standard glass RC trimmers. The use of Voltronics' unique non-rotating piston design provides linear tuning, high "Q", long life, and high self-resonant frequencies. The O-ring seal assures protection up to 40 p.s.i. against dust, moisture, flux, solder, and cleaning solvents.

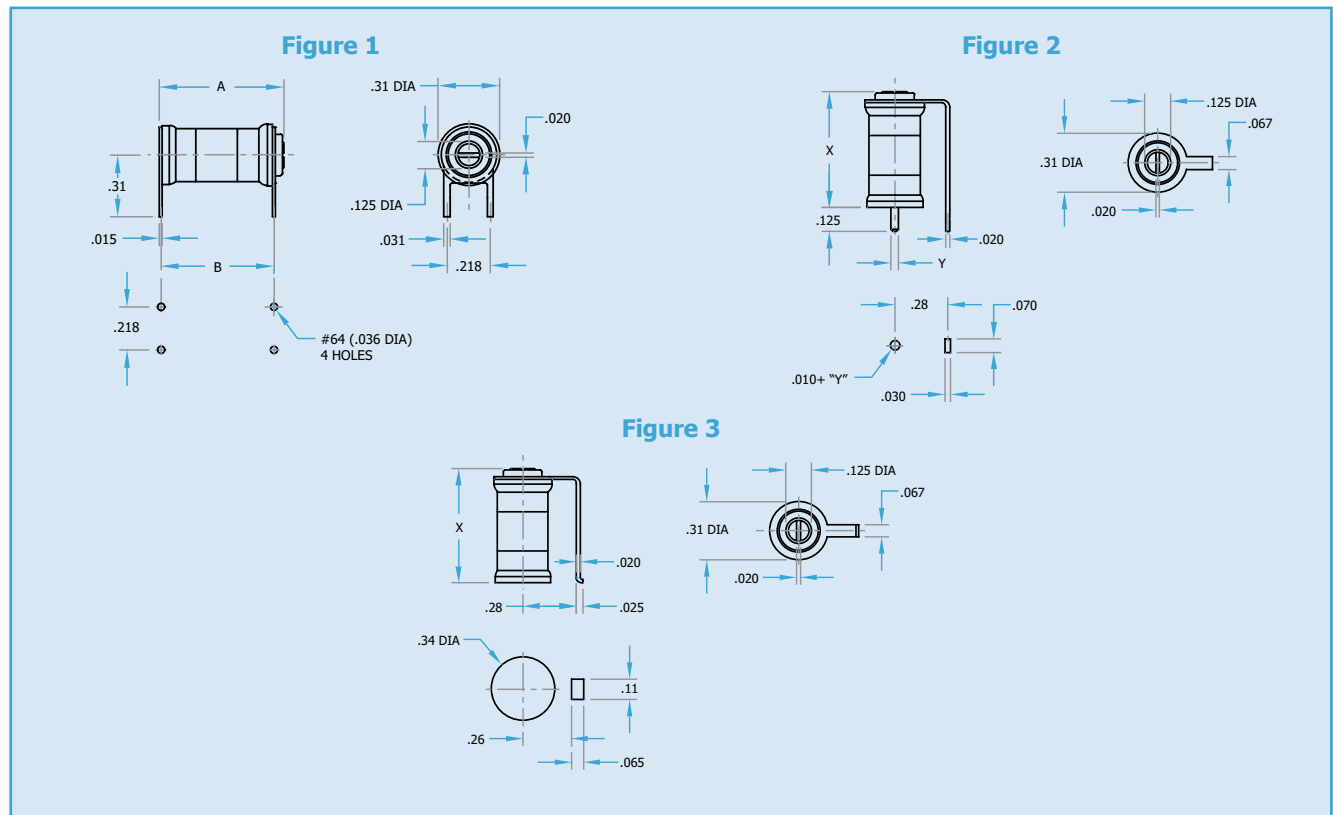
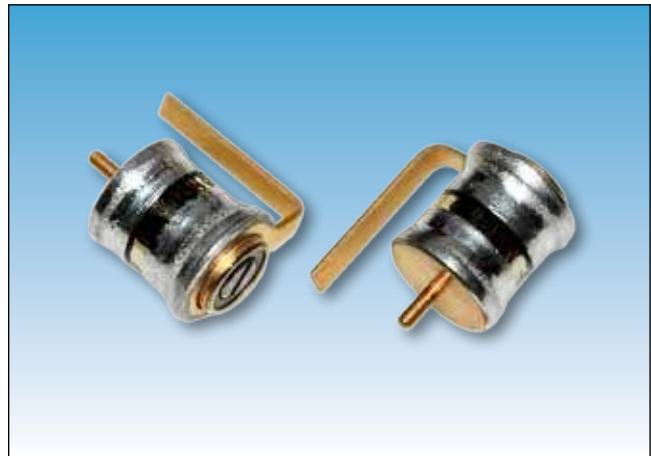

Dielectric	Capacitance Range (pF)		Q (Min.) at 1 MHz	Horizontal Mount Figure 1		Vertical Mount* Figure 2		Surface Mount Figure 3		
	From Below	To Above		Type	A ± .06	B ± .03	Type	X ± .03	Type	X ± .03
EMBEDDED BAND GLASS	1.5	10	800	SP10	.370	.300	SF10A	.340	SM10	.340
	1.5	20	800	SP20	.440	.370	SF20A	.410	SM20	.410
	1.5	30	800	SP30	.520	.450	SF30A	.490	SM30	.490
	1.5	40	800	SP40	.630	.560	SF40A	.600	SM40	.600

"Y" dimension-standard - .040". For non-standard, change "A" in type number to "B" for .063" or "C" for .093".

*SF styles available with dual leads from top similar to AF styles on page 14.

General specifications on page 34 apply except:

1. DC Working Voltage: 250
2. Tuning torque: 0.5 to 5 inch ounces
3. Tolerance: XXX ± .005

Extended Range Glass Trimmers - H Series



The "H" Series increases the standard maximum capacitance values of Voltronics' glass trimmer capacitors by almost 100%. This is achieved by a new and unique technique which makes the wall of the inner glass tube thinner than was previously possible.

General specifications for the "H" Series are the same as those of standard embedded band glass trimmers (see Page 34) with the following exceptions:

DC Working Voltage: 125
Temperature Coefficient: $-150 \pm 150 \text{ ppm}/^\circ\text{C}$

Type	Capacitance Range (pF)		Q (Min.) at 1 MHz	Fig.	A \pm .06	B \pm .03
	From Below	To Above				
Horizontal Printed Circuit						
HSP19	2	19	1000	1	0.37	0.3
HSP34	2	34	900		0.44	0.37
HSP46	2	46	800		0.52	0.45
HSP64	2	64	700		0.63	0.56
HTP96C	2	96	600	2	0.91	0.88
HTP130C	2	130	500		1.16	1.13
HTP210C	2	210	350		1.75	1.73
HTP250C	2	250	250		1.98	1.95
Vertical Printed Circuit						
					A \pm .03	
HSF19	2	19	1000	3	0.34	
HSF34	2	34	900		0.41	
HSF46	2	46	800		0.49	
HSF64	2	64	700		0.6	
Surface Mount						
HSM19	2	19	1000	4	0.34	
HSM34	2	34	900		0.41	
HSM46	2	46	800		0.49	
HSM64	2	64	700		0.6	
Panel Mount						
HTM19C	2	19	1000	5	0.37	
HTM34C	2	34	900		0.45	
HTM46C	2	46	800		0.52	
HTM64C	2	64	700		0.63	
HTM96C	2	96	600		0.92	
HTM130C	2	130	500		1.17	
HTM210C	2	210	350		1.77	
HTM250C	2	250	250		2	

Figure 1

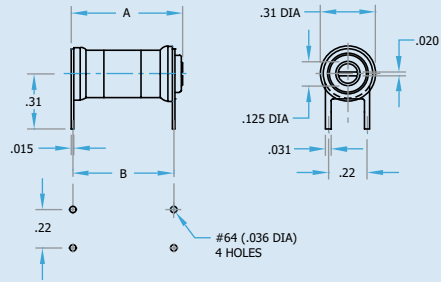

Figure 2

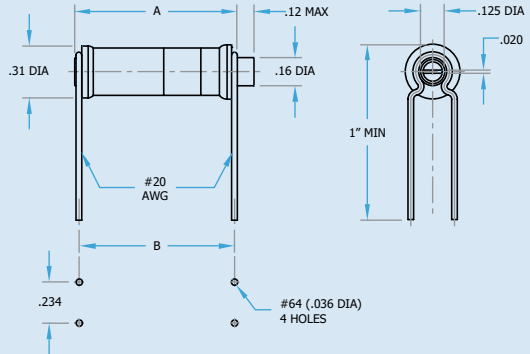

Figure 3

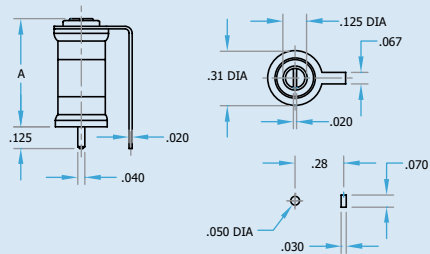

Figure 4

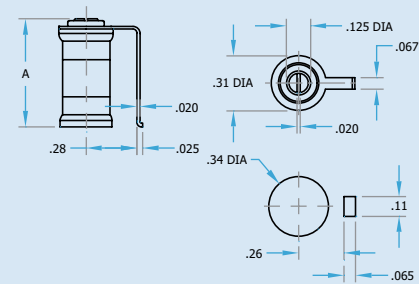
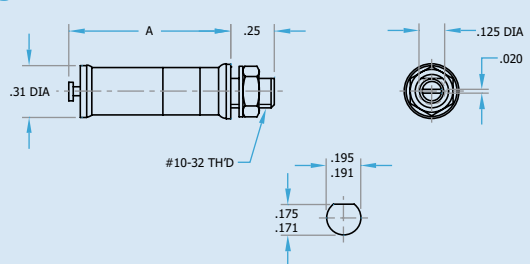
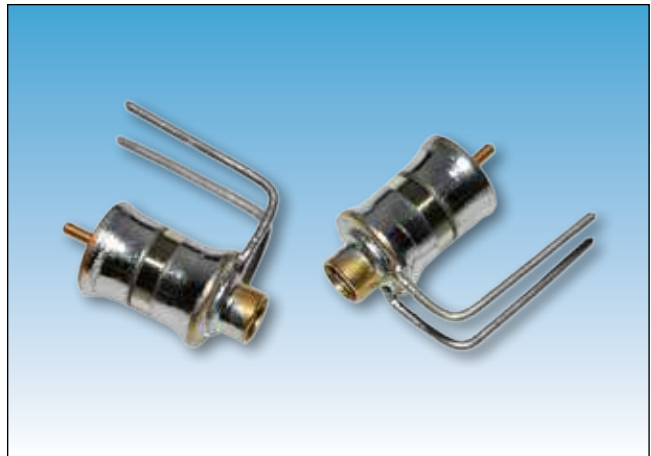
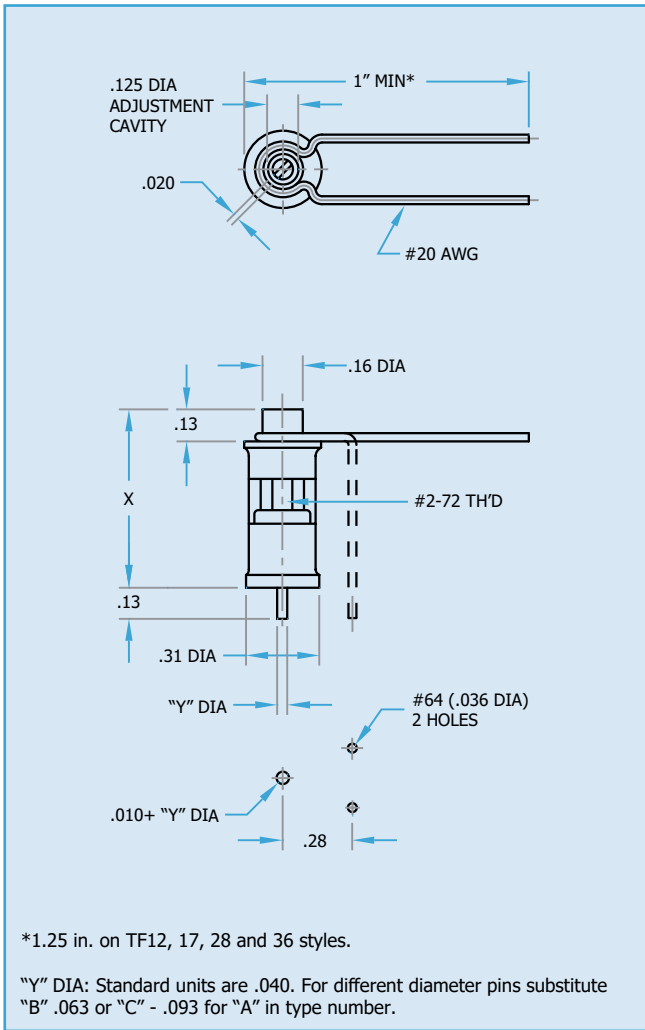

Figure 5





Type	Capacitance Range (pF)		X ± .03	Q (Min.) at 1 MHz	DCWV
	From Below	To Above			
Annular Band					
TF5A	0.8	4.5	0.47	650	750
TF6A	0.8	5.5	0.47	700	750
TF8A	1	8.5	0.62	700	750
TF9A	0.8	8.5	0.7	650	750
TF11A	1	11	0.7	700	750
TF12A	0.8	12	0.9	650	750
TF17A	0.8	16	0.9	700	750
Embedded Band					
TF10A	1.2	10	0.43	800	500
TF14A	1.5	14	0.53	700	1000
TF15A	1.2	16	0.48	800	500
TF16A	1	16	0.53	800	1000
TF22A	2	22	0.58	800	500
TF25A	2	25	0.58	800	500
TF28A	1	28	0.77	700	1000
TF36A	1	36	0.77	800	1000

General specifications on Page 34

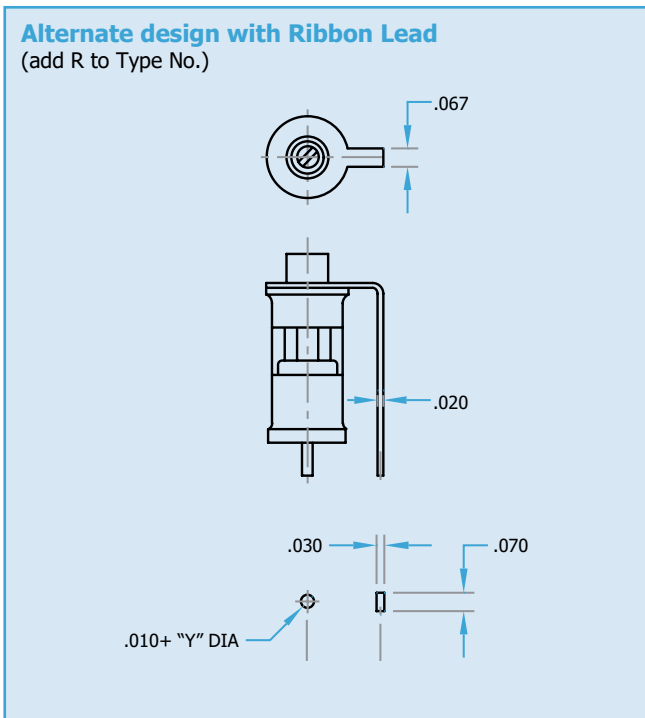

These ranges are panel mount versions of Voltronics' glass and quartz dielectric trimmers. Available sealed or unsealed in Annular Band Glass, Embedded Band Glass and Quartz, the capacitance values are significant, up to 180pF max with 178pF of tunable range. All three dielectric options are also available in MIL Std versions featuring PC38, PC39 and PC48 designations.

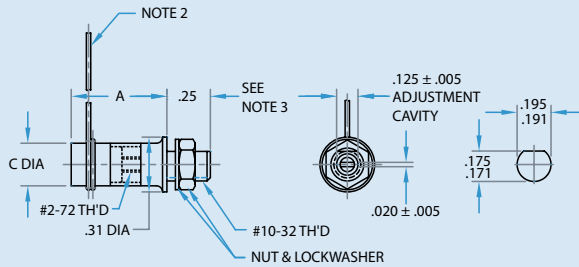

Fig. 1

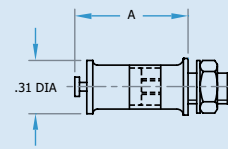

Fig. 2

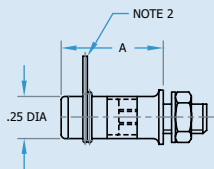

Fig. 3

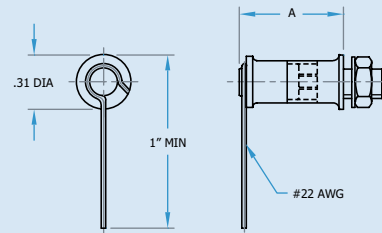
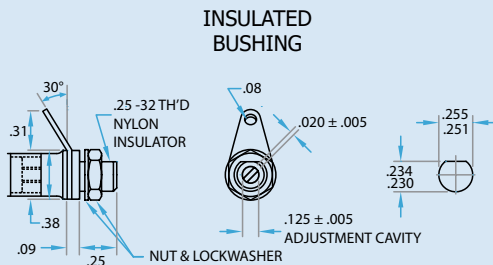

Fig. 4

Notes:

1. Fig. 2, 3 and 4 parts have same end view as Fig. 1.
 2. All leads #22 AWG and 2" Min. long except for all TM5-, TM6-, TM10- and QM2- parts which are #24 AWG.
 3. Mounting bushing #10-32 x .25 long except for all TM10- and TM15- parts which are #10-32 x .16 long.
 4. C diameter of Fig. 1 parts .27 on embedded band units and .25 on all other parts.
- Detailed General Specifications on Page 34.

Optional configurations



Insert "I" Between "T" and "M" in Type Number (eg. TIM9C)

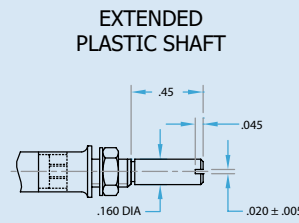

Add "EI" to End of Type Number (eg. TM9EI)

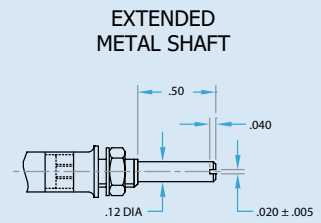

Add "E" to End of Type Number (eg. TM9CE)

Glass Annular Band

Capacitance Range (pF)		Q (Min.) 1 MHz	UNSEALED 750 DCWV (Fig. 1)			SEALED, METAL CAP, TURRET TERMINAL 750 DCWV (Fig. 2)		SEALED, GLASS END 1,250 DCWV (Fig. 3)		
From below	To above		A±.03	Type	MIL Designation	A±.03	Type	A±.03	Type	MIL Designation
0.8	4.5	650	.31	TM5	PC40J4R5**	.41	TM5C	.36	TM5G	PC38J4R5**
0.8	5.5	700	.31	TM6	P050J5R5	.41	TM6C	.36	TM6G	PC48J5R5
0.8	8.5	650	.55	TM9	PC40J8R5**	.63	TM9C	.59	TM9G	PC38J8R5**
1.0	11.0	700	.55	TM11	PC50J110	.63	TM11C	.59	TM11G	PC48J110
0.8	12.0	650	.75	TM12	PC40H120**	.83	TM12C	.81	TM12G	PC38H120**
0.8	16.0	700	.75	TM17	PC50H160	.83	TM17C	.81	TM17G	PC48H160
0.8	18.0	650	1.00	TM18	PC40H180**	1.09	TM18C	1.06	TM18G	PC38H180**
0.8	21.0	700	1.13	TM21	—	1.22	TM21C	—	—	—
0.8	23.0	700	1.00	TM23	PC50H230	1.09	TM23C	1.06	TM23G	PC48H230
0.8	30.0	650	1.59	TM30	PC40H300**	1.69	TM30C	1.66	1M30G	PC38H300**
0.8	38.0	700	1.59	TM38	PC50H380	1.69	TM38C	1.66	TM38G	PC48H380

Glass Embedded Band

Capacitance Range (pF)		Q (Min.) 1 MHz	UNSEALED 1,000 DCWV (Fig. 1)		SEALED, METAL CAP, TURRET TERMINAL 1,000 DCWV (Fig. 2)			SEALED, METAL CAP, 1,000 DCWV (Fig. 4)	
From below	To above		A±.016	Type	A±.03	Type	MIL Designation	A±.03	Type
2.0	10.0	800	.28	TM10*	.37	TM10C*	—	.35	TM10M*
1.5	14.0	700	.38	TM14	.47	TM14C	—	.45	TM14M
1.2	16.0	800	.33	TM15*	.42	TM15C*	—	.40	TM15M*
1.0	16.0	800	.38	TM16	.47	TM16C	PC39G160	.45	TM16M
2.0	25.0	800	.42	TM25	.52	TM25C	—	.50	TM25M
1.0	28.0	700	.61	TM28	.70	TM28C	—	.69	TM28M
1.0	36.0	800	.61	TM36	.70	TM36C	PC39G360	.69	TM36M
1.0	42.0	700	.83	TM42	.92	TM42C	—	.91	TM42M
1.0	52.0	800	.83	TM52	.92	TM52C	PC39G520	.91	TM52M
1.0	60.0	650	1.08	TM60	1.17	TM60C	—	1.16	TM60M
1.0	75.0	700	1.08	TM75	1.17	TM75C	PC39G750	1.16	TM75M
1.0	90.0	600	1.67	TM90	1.77	TM90C	—	1.75	TM90M
1.0	120.0	600	1.67	TM120	1.77	TM120C	P039G121	1.75	TM120M
2.0	180.0	500	1.91	TM180*	2.00	TM180C*	—	1.98	TM180M*

Quartz

Capacitance Range (pF)		Q (Min.) 1 MHz	UNSEALED 750 DCWV (Fig. 1)			SEALED, QUARTZ END 1,250 DCWV (Fig. 3)		
From below	To above		A±.03	Type	MIL Designation	A±.03	Type	MIL Designation
0.6	1.8	2000	.30	QM2	PC40Q1R8	.36	QM2G	PC38Q1R8
0.8	5.5	2000	.55	QM6	P040Q5R5	.63	QM6G	PC38Q5R5
0.6	9.5	2000	.98	QM10	PC40Q9R5	1.06	QM10G	PC38Q9R5
0.8	16.0	2000	1.59	QM16	PC40Q160	1.66	QM16G	PC38Q160

*Parts Rated 500 DCWV

**MIL-C-14409B parts not listed in MIL-C-14409D

These ranges are horizontal mount versions of Voltronics glass and quartz dielectric trimmers. Available sealed or unsealed in Annular Band Glass, Embedded Band Glass and Quartz, the capacitance values are significant, up to 180pF max with 178pF of tunable range. All three dielectric options are also available in MIL Std versions featuring PC42, PC43 and PC52 designsations.

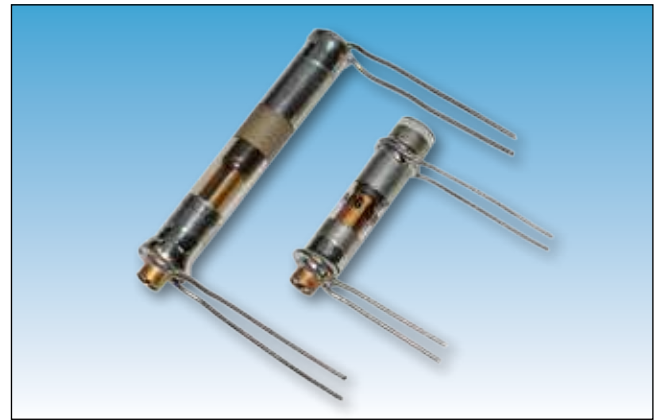

Fig. 1

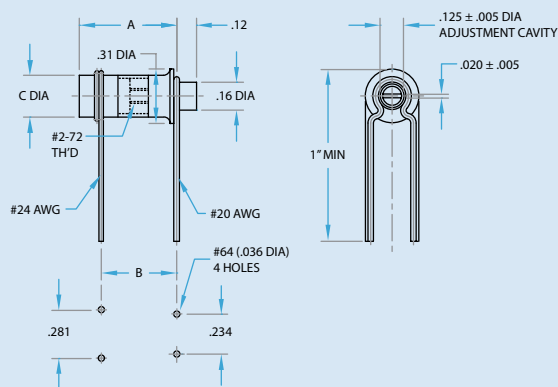

Fig. 2

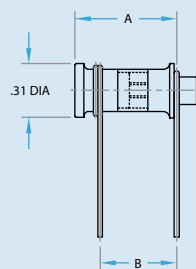

Fig. 3

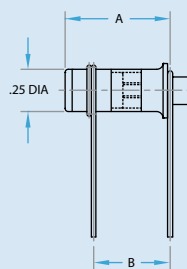
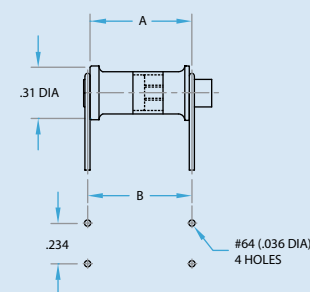

Fig. 4



Notes:

1. All Fig. 2 thru Fig. 4 parts have same end view as Fig. 1. Fig's 2 and 3 have mounting dimensions of Fig. 1
2. C diameter of Fig. 1 parts .27 for embedded band and .25 on all other parts.

Detailed General Specifications on Page 34.

Optional configurations

EXTENDED PLASTIC SHAFT

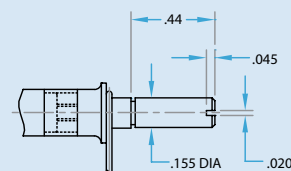

Add "EI" to End of Type Number (eg. TP9CEI)

PRINTED CIRCUIT LUG

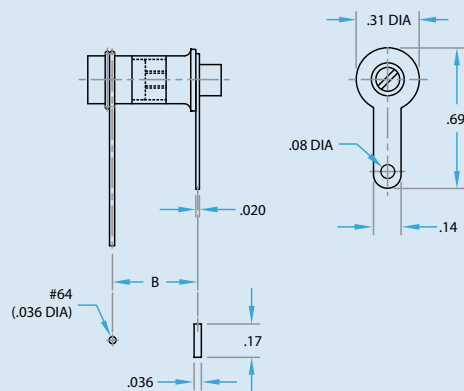

Add "L" to End of Type Number (eg. TP28L)

EXTENDED METAL SHAFT

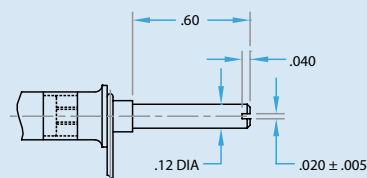

Add "E" to End of Type Number (eg. TP9EI)

Glass Annular Band

Capacitance Range (pF)		Q (Min.)	Unsealed 750 DCWV (Fig. 1)				Sealed, Metal Cap 750 DCWV (Fig. 2)			Sealed, Glass End, 1,250 DCWV						
From Below	To Above		1 MHz	A±.03	B±.03	Type	MIL Designation	A±.03	B±.03	Type	Smaller (Fig. 3)			Larger MIL Size (Fig. 3)		
										A±.03	B±.03	Type	A±.06	B±.03	Type	MIL Designation
0.8	4.5	650	.31	.25	TP5	PC41J4R5**	—	—	—	.39	.25	TP5G	.63	.50	TP5GA	PC42J4R5**
0.8	5.5	700	.31	.25	TP6	PC51J5R5	—	—	—	.39	.25	TP6G	.59	.50	TP6GA	PC52J5R5
0.8	8.5	650	.56	.44	TP9	PC41J8R5**	.58	.44	TP9C	.61	.44	TP9G	.88	.70	TP9GA	PC42J8R5**
1.0	11.0	700	.56	.44	TP11	PC51J110	.58	.44	TP11C	.61	.44	TP11G	.84	.70	TP11GA	PC52J110
0.8	12.0	650	.77	.63	TP12	PC41H120**	.78	.63	TP12C	.83	.63	TP12G	1.08	.84	TP12GA	PC42H120**
0.8	16.0	700	.77	.63	TP17	PC51H160	.78	.63	TP17C	.83	.63	TP17G	1.05	.84	TP17GA	PC52H160
0.8	18.0	650	1.03	.88	TP18	PC41H180**	1.05	.88	TP18C	1.08	.88	TP18G	1.33	1.02	TP18GA	PC42H180**
0.8	21.0	700	1.14	1.00	TP21	—	1.17	1.00	TP21C	—	—	—	—	—	—	—
0.8	23.0	700	1.03	.88	TP23	PC51H230	1.05	.88	TP23C	1.08	.88	TP23G	1.30	1.02	TP23GA	PC52H230
0.8	30.0	650	1.61	1.38	TP30	PC41H300**	1.64	1.38	TP30C	1.67	1.38	TP30G	1.92	1.47	TP30GA	PC42H300**
0.8	38.0	700	1.61	1.38	TP38	PC51H380	1.64	1.38	TP38C	1.67	1.38	TP38G	1.89	1.47	TP38GA	PC52H380



Glass Embedded Band

Capacitance Range (pF)		Q (Min.)	Unsealed 1,000 DCWV (Fig. 1)			Sealed, Metal Cap, Turret Terminal 1,000 DCWV (Fig. 4)			Sealed, Metal Cap, 1,000 DCWV Larger MIL Size (Fig. 4)			
From Below	To Above		1 MHz	A±.03	B±.06	Type	A±.03	B±.06	Type	A±.03	B±.06	Type
2.0	10.0	800	.28	.25	TP10*	.35	.33	TP10C*	—	—	—	—
1.5	14.0	700	.39	.33	TP14	.45	.42	TP14C	.73	.69	TP14CA	—
1.2	16.0	800	.33	.28	TP15*	.41	.39	TP15C*	—	—	—	—
1.0	16.0	800	.39	.33	TP16	.45	.42	TP16C	.73	.69	TP16CA	PC43G160
2.0	25.0	800	.44	.36	TP25	.50	.47	TP25C	—	—	—	—
1.0	28.0	700	.63	.50	TP28	.70	.67	TP28C	.97	.92	TP28CA	—
1.0	36.0	800	.63	.50	TP36	.70	.67	TP36C	.97	.92	TP36CA	PC43G360
1.0	42.0	700	.84	.73	TP42	.91	.88	TP42C	1.19	1.14	TP42CA	—
1.0	52.0	800	.84	.73	TP52	.91	.88	TP52C	1.19	1.14	TP52CA	PC43G520
1.0	60.0	650	1.09	.91	TP60	1.16	1.13	TP60C	1.42	1.38	TP60CA	—
1.0	75.0	700	1.09	.91	TP75	1.16	1.13	TP75C	1.42	1.38	TP75CA	PC43G750
1.0	90.0	600	1.69	1.52	TP90	1.75	1.73	TP90C	2.03	1.98	TP90CA	—
1.0	120.0	600	1.69	1.52	TP120	1.75	1.73	TP120C	2.03	1.98	TP120CA	PC43G121
2.0	180.0	500	1.92	1.73	TP180*	1.98	1.95	TP180C*	—	—	—	—

Quartz

Capacitance Range (pF)		Q (Min.)	Unsealed 750 DCWV (Fig. 1)				Sealed, Quartz End, 1,250 DCWV						
From Below	To Above		1 MHz	A±.03	B±.03	Type	MIL Designation	Smaller (Fig. 3)			Larger MIL Size (Fig. 3)		
							A±.03	B±.03	Type	A±.03	B±.06	Type	MIL Designation
0.8	1.8	2000	.31	.25	QP2	PC41Q1R8	.38	.25	QP2G	.63	.50	QP2GA	PC42Q1R8
0.6	5.5	2000	.56	.44	QP6	PC41Q5R5	.64	.44	QP6G	.89	.70	QP6GA	PC42Q5R5
0.6	9.5	2000	1.00	.88	QP10	PC41Q9R5	1.09	.88	QP10G	1.33	1.02	QP10GA	PC42Q9R5
0.8	16.0	2000	1.61	1.38	QP16	PC41Q160	1.69	1.38	QP16G	1.92	1.47	QP16GA	PC42Q160

*Parts Rated 500 DCWV **MIL-C-14409B parts not listed in MIL-C-14409D

Differential Glass Trimmers

For a differential trimmer capacitor, the capacitance of one element increases while the other decreases, with the sum remaining approximately constant.

DIFFERENTIAL STYLES

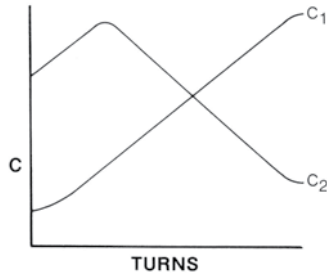

	Fig.	Capacitance Range (pF)				A	B	C
		Min. (1)	Min. (2)	Max. (1) (2)	Typical Crossover			
TM3D	1	1.5	2.0	3	2.4	.31	-	.09
TM8D	1	1.5	2.5	8	5.5	.55	-	.22
TM12D	1	1.5	3.0	12	7.7	.75	-	.31
TM16D	1	1.5	3.5	16	10.1	.94	-	.41
TM28D	1	1.5	5.0	26	16.0	1.44	-	.66
TP3D	2	1.5	2.0	3	2.4	.31	.28	.09
TP8D	2	1.5	2.5	8	5.5	.55	.45	.22
TP12D	2	1.5	3.0	12	7.7	.75	.61	.31
TP16D	2	1.5	3.5	16	10.1	.94	.75	.41
TP28D	2	1.5	5.0	26	16.0	1.44	1.13	.66

Note: For sealed versions, add "G" to part number, ie., TM8DG. The "A" dimension will be 0.11" longer.

Fig. 1

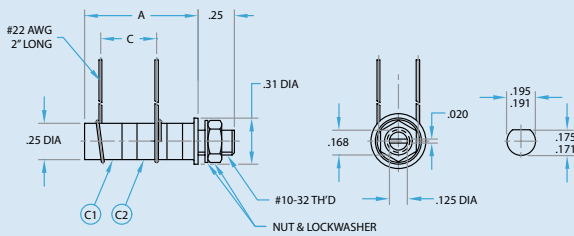
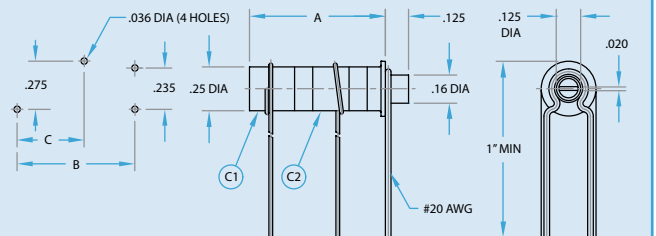

Fig. 2



Split Stator Glass Trimmers

Both elements of a split stator trimmer tune at approximately the same rate.

SPLIT STATOR STYLES

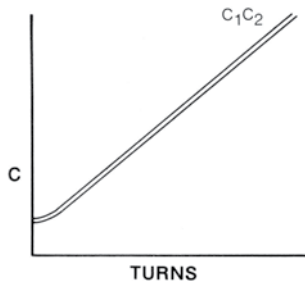

	Fig.	Capacitance Range (pF)				A	B
		Plate/Plate		Plate/Brushing			
		Min.	Max.	Min.	Max.		
TM4S	1	0.8	2.0	0.8	4.2	.55	-
TM9S	1	1.5	4.5	0.8	9.0	1.02	-
TM14S	1	2.0	7.0	1.0	14.0	1.67	-
TP4S	2	0.8	2.0	0.8	4.2	.55	.47
TP9S	2	1.5	4.5	0.8	9.0	1.02	.91
TP14S	2	2.0	7.0	1.0	14.0	1.67	1.53

Note: For sealed versions, add "G" to part number, ie., TM4SG. The "A" dimension will be 0.11" longer.

Fig. 1

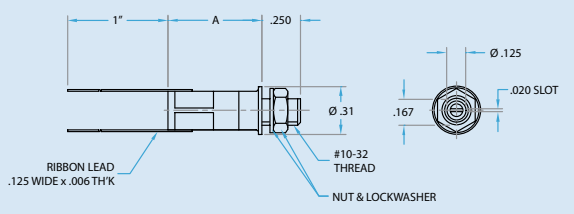
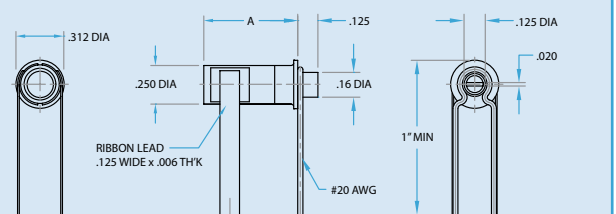

Fig. 2



General Specifications on page 34 apply except:

1. DC Working Voltage: 500
2. Temperature coefficient: 0±100 ppm/°C.

METAL (Fig.1)

Part No.	Tip A	Tip B	Capacitor Series
TT-100	.110 x .018	.070 x .012	A, E, K, KE, DRO, Glass, NT P
TT-200	.110 x .018	.032 x .088	A, E, K, KE, DRO, Glass, NT__
TT-300	.060 x .018	.070 x .012	A1, A3 P
TT-400	.060 x .018	.036 x .012	A1, A3, A2, A4

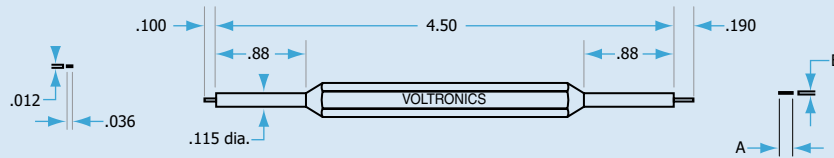

Fig. 1

Ceramic (Fig.2)

Part No.	Tip A	Capacitor Series
TT-500	.07X.016	A1, A3, A, E, K, KE, DRO
TT-600	.10X.016	Glass, NT
TT-700	.050X.016	P
TT-900	.038X.016	A2, A4

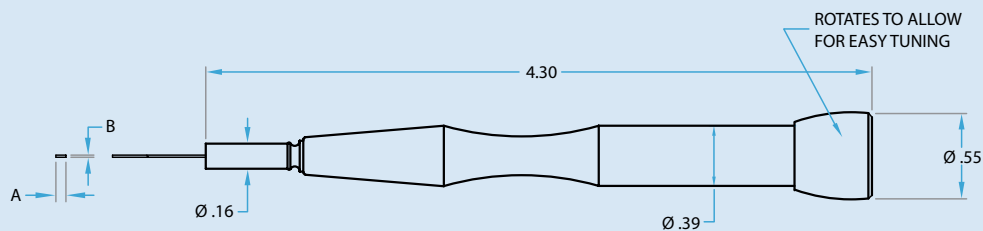

Fig. 2

Notes: The TT-500 thru TT-900 tuning tools are ideal for continual use. They fit into the hand with the rotatable top fixed in the palm. The tips are made of high strength ceramic. Use these tools where metal tips affect tuning.

Microwave Tuning Elements



Johanson Microwave Tuning Elements with the self-locking, constant torque drive mechanism, require no external locking devices and permit "one hand" tuning with virtually no dynamic tuning noise which could otherwise imperil associated solid state devices under "power on" conditions. This self-locking feature and high tuning resolutions assure unparalleled control over the most critical of complex circuit tuning adjustments.

In many instances, the use of Johanson Tuning Elements has halved technical tuning time.

Description

- Variable reactance for microwave circuits
- Available with mounting bushing and/or individual tuning rotor
- High resolution tuning
- Exceeds MIL-PRF-14409 vibration requirements

Features

- Self-locking torque mechanism, no lock nuts required
- Gold and chromate finish
- Available in metallic, dielectric and resistive versions

Applications

- Combine applications
- Interdigital applications
- Impedance transformers
- Impatt and Gunn oscillators
- Microstrip and stripline circuits
- Attenuators
- Coaxial structures
- Waveguide circuitry

Contact factory for "Microwave Product Application Guide" brochure.



Tap Part No.	Thread (UNS-2)	Recommended Tap Drill
7054	.086-56	#51 (.067)
7059	.156-64	9/64 (.1406)
7060	.120-80	#36 (.1065)
7061	.190-64	#17 (.173)
7062	.234-64	7/32 (.2187)
7063	.250-64	15/64 (.2344)
7064	.094-80	#45 (.082)

Recommended Tuning Tools

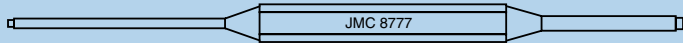
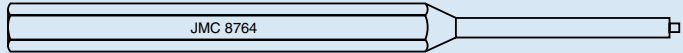
Tuning Element	Diameter	Johanson Part Number
Microwave Type	.130	8777 
Microwave Type	.130	8764 

Note: The use of a Johanson tuning tool is recommended, improper screw driver size will cause internal thread damage.

Dielectric Tuning Elements



Dielectric

Part Number	Dimensions								Mounting		
	A	B	C	D	E	F	G	ROD MAT'L	THD. (UNS-2A)	Torque (oz. in)	Slot
6933-4	0.240	0.168	0.062	0.135	0.035	0.260	0.138	Sapphire	0.120 to 80	10	0.015W x 0.020DP
6933-5		0.130	0.035			0.222	0.100				
6934-3	0.360	1.205	0.152	0.265	0.145	1.309	1.175	Alumina	0.234 to 64	50	0.031W x 0.025DP
6934-4		1.105				1.209	1.075				
6934-5		0.905				1.009	0.875				
6934-6	0.360	0.115	0.152	0.265	0.035	0.219	0.085	Sapphire	0.234 to 64	50	0.031W x 0.025DP
6935-10		0.265			0.145	0.369	0.235				
6935-11	0.360	0.265	0.152	0.265	0.145	0.369	0.235	Alumina	0.234 to 64	50	0.031W x 0.025DP
6935-12		0.525				0.643	0.495				



Resistive

Part Number	Dimensions								Mounting		
	A	B	C	D	E	F	G	ROD MAT'L	THD. (UNS-2A)	Torque (oz. in)	Slot
6950-2	0.240	0.168	0.062	0.135	0.035	0.260	0.138	Eccosorb	0.120 to 80	10	0.015W x 0.020DP
6950-3		0.130	0.078			0.222	0.100				
6952-1	0.360	0.250	0.152	0.265	0.145	0.034	0.220	Eccosorb	0.234 to 64	50	0.031W x 0.025DP
6952-2		0.185				0.289	0.155				

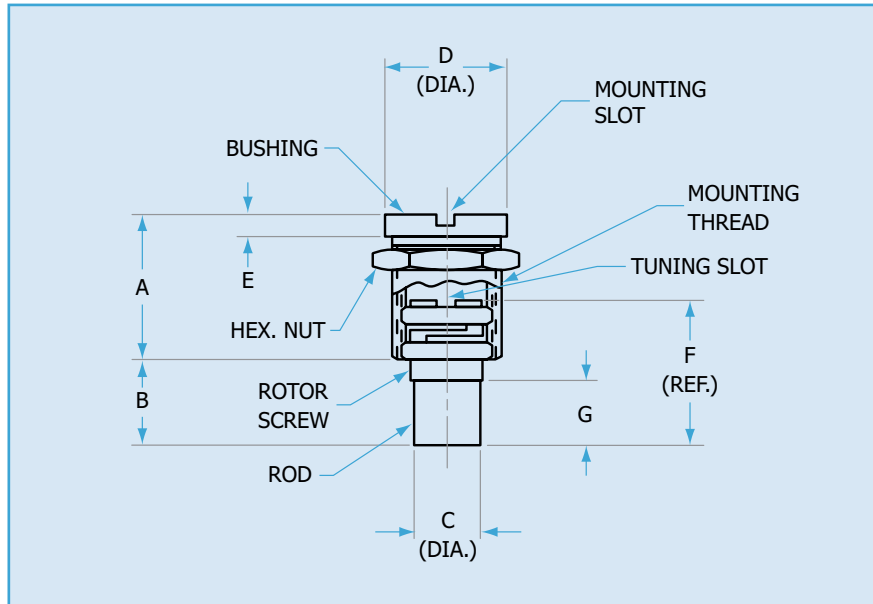

Recommended Tuning Tool

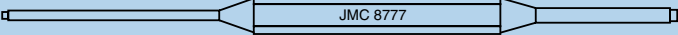
Tuning Element	Diameter	Johanson Part Number
Dielectric & Resistive Type	.130	8777 

Note: The use of a Johanson tuning tool is recommended, improper screw driver size will cause internal thread damage.

Metallic Tuning Elements



Metallic

Part Number	Dimensions								Mounting					
	Fig.	A	B	C	D	E	F	G	THD. (UNS-2A)	Torque (oz. in)	Slot			
6924-9	1	0.240	0.148	0.072	0.135	0.035	0.240	0.035 W x 0.156 A/F	0.120 to 80	10	0.015 W x 0.020 DP			
6924-10		0.120	0.075				0.167							
6924-11		0.240										0.122		
6924-12		0.120	0.030											
6925-4		0.250	0.905	0.125	0.210	0.037	0.250	0.035 W x 0.218 A/F				0.190 to 64	30	0.031 W x 0.020 DP
6925-5		0.125	0.115				0.210							
6926-13		0.210	0.106	0.267	0.145	0.360		0.040 W x 0.281 A/F						
6926-17			0.180				0.265							
6927-2		0.360	0.250	0.267	0.240	0.450		0.035 W x 0.218 A/F						
6927-3			0.255											
6928-6		0.450	0.345	0.125	0.210	0.042	0.552	0.035 W x 0.218 A/F				0.190 to 64	10	0.031 W x 0.020 DP
6929-2		0.552	0.450											
6965-1	0.720	0.500	0.345	0.531	0.040	0.720	0.078 W x 0.562 A/F	0.469 to 32	240	0.031 W x 0.030 DP				

LC Type

Part Number	Dimensions								Mounting		
	Fig.	A	B	C	D	E	F	G	THD. (UNS-2A)	Torque (oz. in)	Slot
6939-2	2	0.482	0.148	0.072	0.187	0.047	0.240	0.232	0.156 to 64	20	0.030 W x 0.025 DP
6940-1		0.555	0.450	0.125	0.265		0.552		0.232		
6941-1		1.230	0.346	0.160	0.280		0.450		0.250 to 64	90	

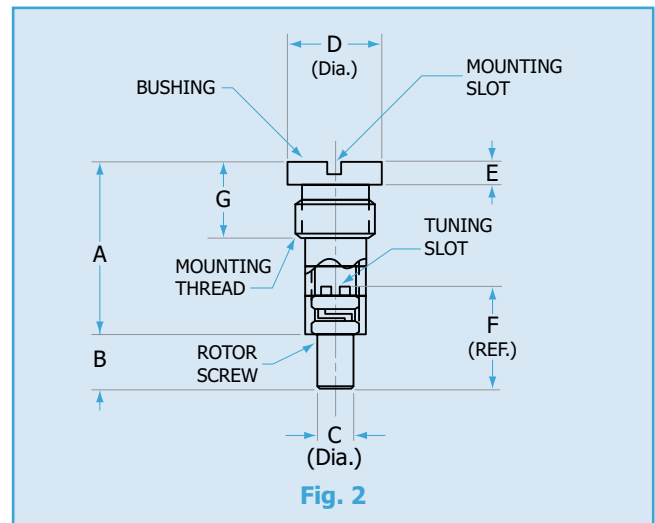
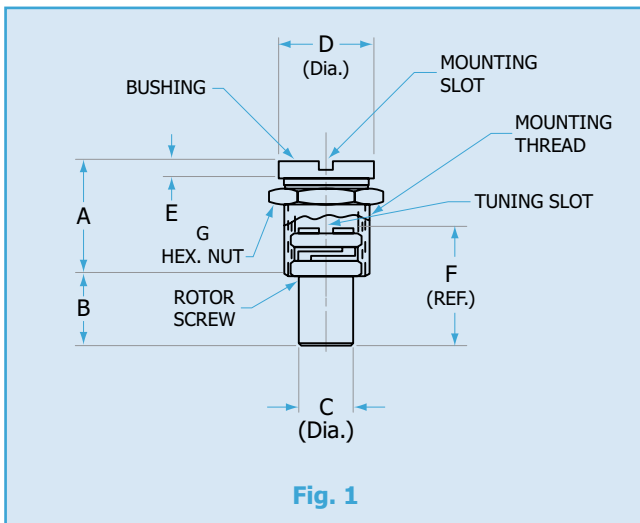

Recommended Tuning Tool

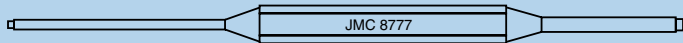
Tuning Element	Diameter	Johanson Part Number
Metallic & LC Type	.130	8777 

Note: The use of a Johanson tuning tool is recommended, improper screw driver size will cause internal thread damage.

Tuning Screw Torque Bushings



Posi-torque Bushings are precision devices designed for applications requiring precision, low loss high resolution tuning.

The self-locking, constant torque drive mechanism eliminates the need for locking nuts and assures stable, noise free adjustment in RF to Microwave frequencies.

Posi-Torque Bushings are universal and can be used with standard SI and US customary screws.



METAL (Fig.1)

Part No.	A	B	C	D	E	F	Thread	Mounting hole (dia.)
LB1020-1	.145	.1247	.112	.030	.035	.130	#0(.060) -80	.1240/.1242
LB1021-1	.175	.1552	.140	.030	.035	.150	#2(.086) -56	1545/1547
LB1020-2	-	.1552	.140	-	.035	.130	#2(.086) -56	1545/1547
LB1022-1	.300	.2697	.250	.035	.090	.300	#4(.112) -40	.2690/.2692
LB1023-1	.330	.2997	.280	.035	.100	.335	#6(.138) -32	.2690/.2692
LB1023-2	-	.2997	.280	-	.100	.300	#6(.138) -32	.2690/.2692
LB1024-1	.380	.3497	.330	.035	.100	.335	#10(.190) -32	.3490/3492
LB1025-1	.440	.4097	.390	.035	.100	.335	¼(.250) -28	.4090/4092
LB1025-2	-	.4097	.390	-	.100	.300	¼(.250) -28	.4090/4092
LB1026-1	.350	.3197	.300	.035	.100	.335	#8(.164) -32	.3190/3192

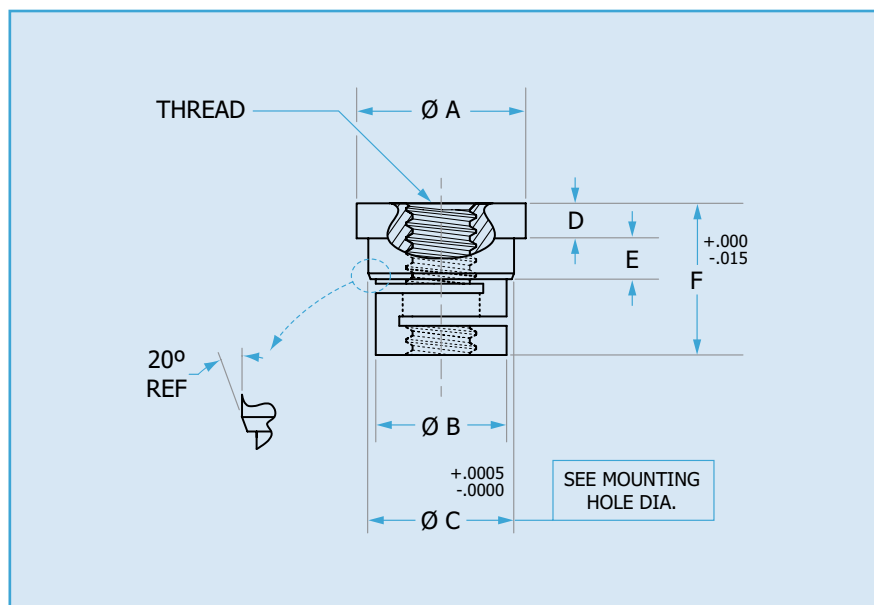

Tuning Rotors



Metallic

Part Number	Dimensions					Mounting			
	Fig.	A	B	C	D	THD. (UNS-2A)	Tap P/N	ROD Mat'l	Slot
L6316-1	1	0.165	0.075	0.072	0.018	0.120 to 80	7060	BRASS	0.015 W x 0.090
L6316-2	2	0.223	0.155	-	0.020				
L6994-2		0.175	0.090	-					
L6995-0	1	0.122	0.030	0.072		0.094 to 80	7064		0.015 W x 0.060
L6995-1		0.167	0.075						
L6995-2		0.240	0.148						
L6995-22		0.217	0.125						
L6996-1		0.250	0.148	0.125		0.156 to 64	7059		0.020 W x 0.120
L6996-5		0.295	0.193						
L6996-6		0.180	0.078						
L6997-0		0.554	0.450					0.160	
L6997-2	0.360	0.256							
L6997-17	0.146	0.042							

LC Type

Part Number	Dimensions					Mounting			
	Fig.	A	B	C	D	THD. (UNS-2A)	Tap P/N	ROD Mat'l	Slot
6930-3	3	0.475	0.345	0.152	0.010	0.190 to 64	7061	ALUMINA	0.020 W x 0.145
6930-5		0.625	0.495						
6930-7		0.884	0.750						
6930-17		0.674	0.490	0.061					
6930-20		0.850	0.716	0.152					
6930-21		0.379	0.195	0.061					

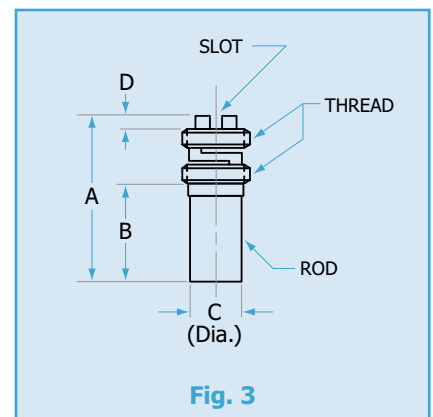
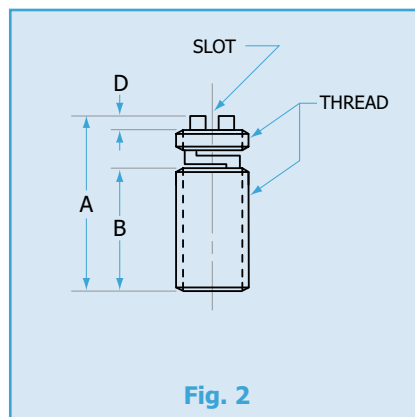
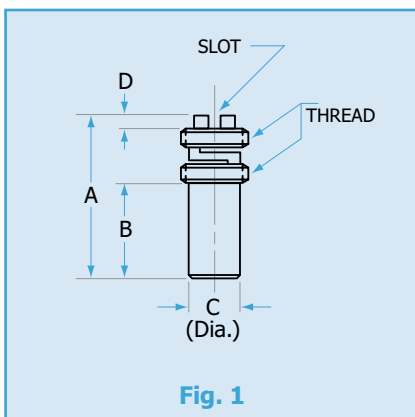

4000 Series

Part Number	Dimensions								NOM. FREQ. (GHz)
	Fig.	A	B	C	D	E	F	G	
4003-1	1	0.360	0.245	0.320	0.02 W x 0.23	0.08 x 0.41	0.375 to 64	0.06 x 0.44	6
4005-1		0.335	0.150	0.210	0.02 W x 0.14	0.08 x 0.28	0.250 to 64	0.060 x 0.31	10
4007-4		0.270	0.084	0.130	0.15 W x 0.09	0.06 x 0.22	0.190 x 64	0.035 x 0.22	18

4010 Series

Part Number	Fig.	A	Rod Material	Disk Material	NOM. FREQ. (GHz)
4010-1	2	0.970	INVAR	BRASS	2
4011-1		0.750			3
4012-1		0.500			4
4012-2		0.625			
4014-1		0.250	INVAR (ONE-PIECE CONSTRUCTION)	9	

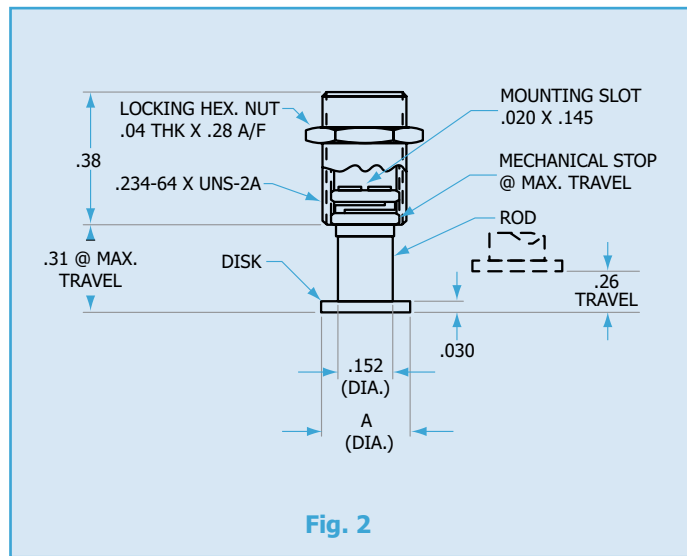
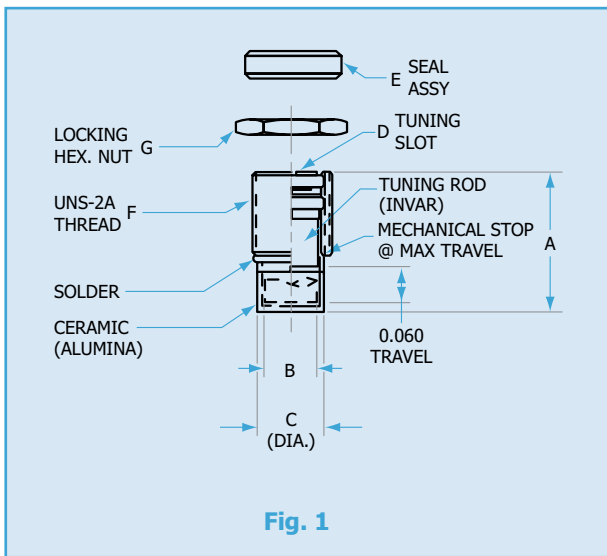



MLC capacitors with silver/palladium (Ag/Pd) terminations have often been used in medical applications where non-magnetic components are required, for example in MRI equipment - however, conventional nickel barrier terminations are not suitable due to their magnetic properties. In addition, RoHS requirement to use lead-free solders would cause an increase in soldering temperatures and cause solder leaching problems for the Ag/Pd termination. This has meant alternatives have had to be found and one solution is to use a copper barrier instead of a nickel barrier, with a tin finish on top. This non-magnetic termination is offered with selected non-magnetic COG/NPO (1B), High Q and X7R (2R1) dielectrics, providing a fully non-magnetic component ($\mu = 1.0000$).

To meet high temperature 260°C soldering reflow profiles as detailed in J-STD-020, COG/NPO (1B) dielectrics are supplied with FlexiCap™ or sintered termination whilst X7R (2R1) dielectrics are supplied only with the FlexiCap™ termination.

Available in chip or ribbon led format for certain case sizes (please consult Sales Office).



COG/NPO (1B), High Q - minimum/maximum capacitance values

Chip Size	0402	0603	0505	0805	1206	1210	1808	1812	2220
Min Cap	0.1pF	0.1pF	0.2pF	0.2pF	0.5pF	0.3pF	1.0pF	1.0pF	2.0pF
50V 63V	22pF	100pF	220pF	470pF	1.5nF	-	-	-	-
100V	15pF	68pF	150pF	330pF	1.0nF	2.2nF	2.2nF	4.7nF	10nF
150V	10pF	47pF	100pF	220pF	680pF	1.5nF	1.5nF	3.3nF	6.8nF
200V 250V	6.8pF	33pF	56pF	150pF	470pF	1.0nF	1.0nF	2.2nF	4.7nF
300V	-	27pF	47pF	120pF	390pF	820pF	820pF	1.8nF	3.9nF
500V				68pF	270pF	680pF	680pF	1.5nF	3.3nF
630V				-	150pF	390pF	390pF	1.0nF	2.2nF
1000V				-	82pF	220pF	220pF	680pF	1.5nF
2000V				-	18pF	68pF	68pF	150pF	470pF
3000V				-	-	-	-	68pF	150pF

Min Capacitance Tolerance
 $\pm 0.05\text{pF}$ ($< 4.7\text{pF}$)
 0.1pF ($\geq 4.7\text{pF}$ & $< 10\text{pF}$)
 $\pm 1\%$ ($\geq 10\text{pF}$)

X7R (2R1) - minimum/maximum capacitance values

Chip Size	0402	0603	0805	1206	1210	1808	1812	2220
Min Cap	47pF	100pF	330pF	680pF	1.5nF	2.2nF	3.3nF	6.8nF
16V	10nF	100nF	330nF	1.0 μ F	1.5 μ F	1.5 μ F	3.3 μ F	5.6 μ F
25V	6.8nF	68nF	220nF	820nF	1.2 μ F	1.2 μ F	2.2 μ F	4.7 μ F
50V 63V	4.7nF	47nF	150nF	470nF	1.0 μ F	680nF	1.5 μ F	3.3 μ F
100V	1.5nF	10nF	47nF	150nF	470nF	330nF	1.0 μ F	1.5 μ F
200V 250V	680pF	5.6nF	27nF	100nF	220nF	180nF	470nF	1.0 μ F
500V	-	1.5nF	8.2nF	33nF	100nF	100nF	270nF	560nF
630V			4.7nF	10nF	27nF	33nF	150nF	330nF
1000V			3.3nF	4.7nF	15nF	18nF	56nF	120nF
1200V			-	3.3nF	10nF	10nF	33nF	82nF
1500V			-	2.7nF	6.8nF	6.8nF	22nF	47nF
2000V			-	2.2nF	4.7nF	4.7nF	10nF	27nF

Min Capacitance Tolerance
 $\pm 5\%$

COG/NPO (1B), High Q - High Power RF capacitors - minimum/maximum capacitance values

A range of ultra-low loss High Q ceramic capacitors with COG/NPO (1B) characteristics suitable for high power applications where minimal power loss and very low self heating is demanded.

Common applications include MRI body coils and wireless charging systems operating in the kHz and MHz frequencies.

Available in chip or ribbon led format.

Chip size	Case size 11 - 1111		Case size 25 - 2225		Case size 40 - 4040	
	Min.	Max.	Min.	Max.	Min.	Max.
100V	1.8nF	2.2nF				
150V	1.2nF	1.5nF				
200V	5.7nF	10nF	6.2nF	10nF	16nF	27nF
250V	820pF	1.0nF				
500V	470pF	680pF	5.1nF	5.6nF	13nF	15nF
630V	270pF	390pF	3.6nF	4.7nF	11nF	12nF
1kV	82pF	220pF	1.1nF	3.3nF	5.6nF	10nF
2kV	0.3pF	68pF	510pF	1.0nF	1.6nF	5.1nF
3kV			110pF	470pF	910pF	1.5nF
3.6kV			1pF	47*/100pF	-	-
4kV					620pF	820pF
5kV					360pF	560pF
6kV					160pF	330pF
7.0/7.2kV					1pF	56**/150pF

*47pF max. for dual rated @2.5kVac 30MHz
 **56pF max. for dual rated @5kVac 30MHz.

Non-Magnetic Caps - COG/NP0 (1B), High Q, X7R (2R1)



Surface Mount See MLC Caps catalogue for dimensions.

Ribbon Leaded Silver plated copper ribbon attached with HMP solder - (MP greater than 260°C).

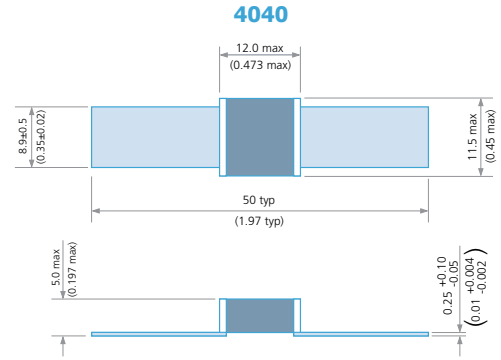
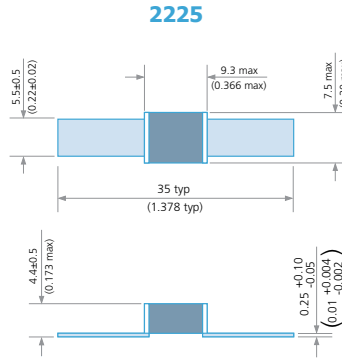
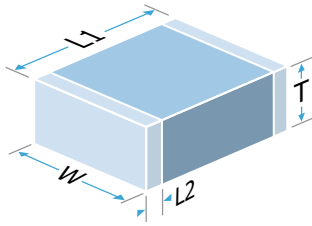

Ordering information - Syfer Non-Magnetic capacitors

Chip size	Termination or Coating (Ribbon Leaded)	Voltage	Capacitance in picofarads (pF)	Capacitance tolerance	Dielectric	Packing	Lead Options	Suffix code
1206	2	500	0223	J	Q	T	-	-
4040	2	7K0	0470	G	Q	B	-	AF9
2225	B	3K0	6P80	G	Q	B	R	W221
0402*	2 = Sintered silver with copper barrier*	50 = 50V	<10pF Insert a P for the decimal point, eg 2P20 = 2.2pF.	<4.7pF H = ±0.05pF B = ±0.1pF C = ±0.25pF D = ±0.5pF	C = COG/NP0 (1B) Q = High Q X = X7R (2R1)	T = 178mm (7") reel R = 330mm (13") reel B = Bulk pack - tubs or trays	R = Ribbon leaded Blank = SM chip	W221 = Leaded W211 = Leaded marked **AF9 = SM standard chip **AF9LM = SM marked standard chip
0603	3 = FlexiCap™ with copper barrier.	100 = 100V	>10pF. 1st digit is 0. 2nd and 3rd digits are significant figures of capacitance code. The 4th digit is number of 0's following eg. 0470 = 47pF 0512 = 5100pF	≥4.7pF ~ <10pF B = ±0.1pF C = ±0.25pF D = ±0.5pF				
0805	4 = Sintered silver with copper barrier*	1K0 = 1kV	Values <1pF in 0.1pF steps, above this values are E24 series	>10pF F = ±1% G = ±2% J = ±5% K = ±10% M = ±20%				
1206	5 = Sintered silver with copper barrier*	2K0 = 2kV						
1111		3K0 = 3kV						
1210		4K0 = 4kV						
1808		5K0 = 5kV						
1812		6K0 = 6kV						
2220		7K0 = 7kV						
2225†	Ribbon Leaded B = Uncoated							
4040†	V = Coated with modified silicone laquer							

Note: *0402 - COG/NP0 (1B) and High Q only. †Ribbon Leads available. **AF9 and AF9LM suffix code only available in 1111, 2225 and 4040 chip sizes.



Ordering information - Voltronics Non-Magnetic capacitors

Chip size	Capacitance	Tolerance	Voltage	Termination	Material	Lead/Packaging
11	470	J	1000	W	F	R
4 0402*	OR1 0.1pF	A ±0.05pF	50 = 50V	W = Ag/Cu/Sn	Q = High Q 0±30ppm/°C	R = Ribbon
5 0505	100 10pF	B ±0.1pF	100 = 100V	S = Pd/Ag	X = X7R (2R1)	T* = Tape & Reel
6 0603*	101 100pF	C ±0.25pF	1000 = 1000V	M = Poly/Cu/Sn		B* = Bulk
8 0805*	102 1000pF	D ±0.5pF		2 = Ag/Cu/Sn - (Q dielectric only)		
11 1111†		F ±1%		3 = Poly/Cu/Sn - (X dielectric only)		
12 1206*		G ±2%		B = Silver - (Q ribbon only)		
13 1210*		J ±5%		V = Silver, laquer Coated - (Q ribbon only)		
18 1812*		K ±10%				
22 2220*		M ±20%				
25 2225†						
38 3838†						
40 4040†						

Note: *Q and X dielectric only. †Ribbon Leads available.



Made from highly stable, low loss dielectric formulations, these traditional porcelain MLCs are known for their high RF power handling capability. Available in all industry common case sizes. The special silver-palladium termination and the proprietary ceramic formulations guarantee consistent non-magnetic performance. All MLCs in these series are RoHS compliant. Chips are available either with standard termination or can be fitted with ribbon leads, depending on your application.

Description

- Porcelain Capacitors • Zero TC • Low Noise • Low ESR, High Q
- High Self-resonance • Established Reliability
- Capacitance range 0.1pF to 5.1nF

Functional Applications

- Impedance Matching • DC Blocking • Bypass • Coupling
- Tuning and Feedback

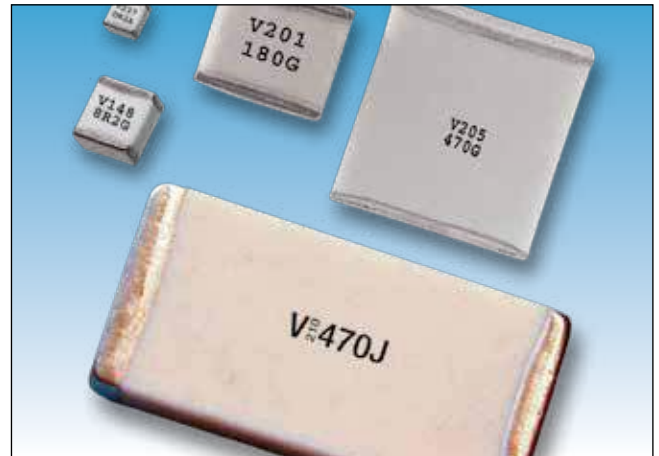

High Power RF capacitors - F & H materials - Minimum/maximum capacitance values

Chip Size	Case size 5 0505		Case size 11 1111		Case size 25 2225		Case size 38 3838	
	Min.	Max.	Min.	Max.	Min.	Max.	Min.	Max.
50V	-	-	680pF	1nF	-	-	-	-
100V	-	-	510pF	620pF	-	-	-	-
200V	36pF	100pF	220pF	470pF	-	-	-	-
250V	0.1pF	33pF	-	-	-	-	-	-
300V	-	-	-	-	2.2nF	2.7nF	-	-
500V	-	-	110pF	200pF	1.5nF	1.8nF	2.7nF	5.1nF
1kV	-	-	0.3pF	100pF	510pF	1.2nF	750pF	2.2nF
1.5kV	-	-	-	-	300pF	470pF	-	-
2kV	-	-	-	-	-	-	-	-
2.5kV	-	-	-	-	0.3pF	270pF	430pF	680pF
3.6kV	-	-	-	-	-	-	110pF	390pF
7.2kV	-	-	-	-	-	-	0.3pF	100pF

Note: Special capacitance values available upon request.

Ordering information - Non-Magnetic capacitors

11	470	J	1000	W	F	R
Chip size	Capacitance	Tolerance	Voltage	Termination	Material	Lead
5 0505	0R1 0.1pF	A ±0.05pF	50 50V	W Ag/Cu/Sn	H AH +90±20ppm/°C	B = Chip
11 1111+	100 10pF	B ±0.1pF	100 100V	S Pd/Ag	F CF 0±15ppm/°C	R =Ribbon
25 2225+	101 100pF	C ±0.25pF	1000 1000V	M Poly/Cu/Sn		
38 3838+	102 1000pF	D ±0.5pF				
		F ±1%				
		G ±2%				
		J ±5%				
		K ±10%				

Note: †Available in chip or ribbon leaded format.

Reeled Quantities

Chip Size	0402	0505	0603	0805	1206	1111 1210	1808	1812	2220	2225
7" Reel	10000	2500	4000	3000	2500	1000/2000	1500	500	500	500
13" Reel	13" reel quantities available on request						6000	2000	2000	2000

Note: Other capacitance values may become available, please contact the Sales Office if you need values other than those shown in the above tables. For dimensions and soldering information, please go to our website www.knowlescapacitors.com.

Typical performance data - chip size 0805 High Q

Typical performance data - chip size 1111 High Q

ESR vs Frequency

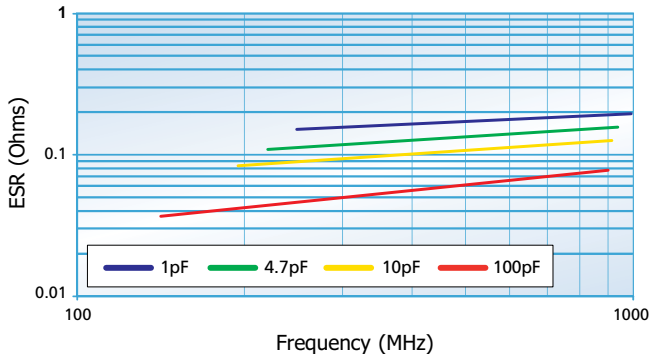

ESR vs Frequency

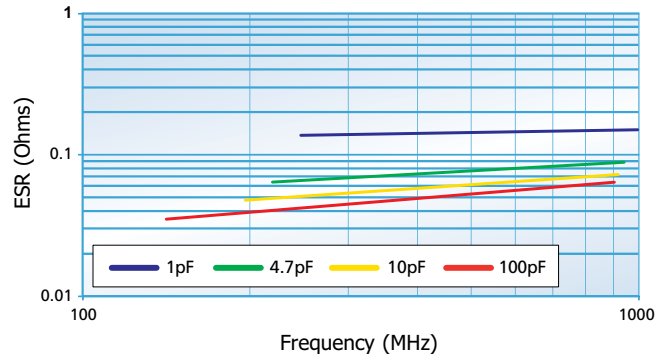

Q vs Capacitance

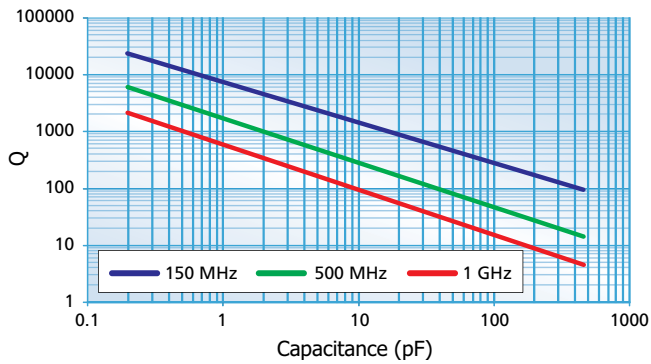

Q vs Capacitance

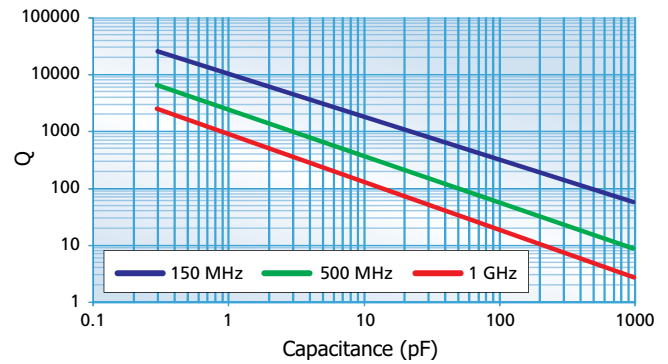

Resonant Frequency vs Capacitance

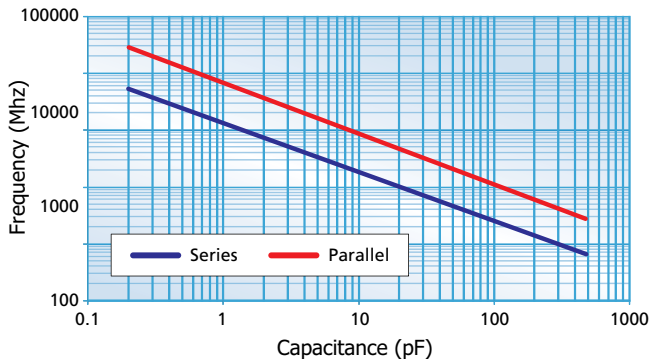

Resonant Frequency vs Capacitance

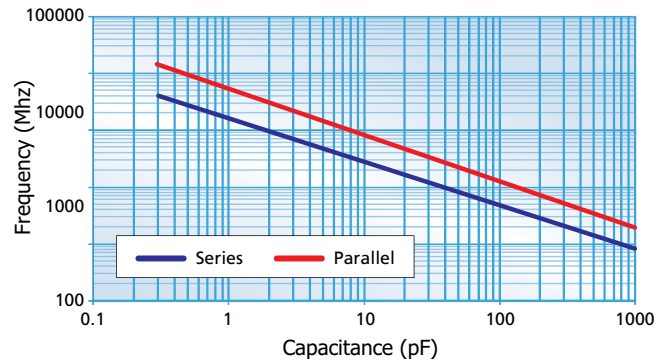

Typical ESR vs Frequency

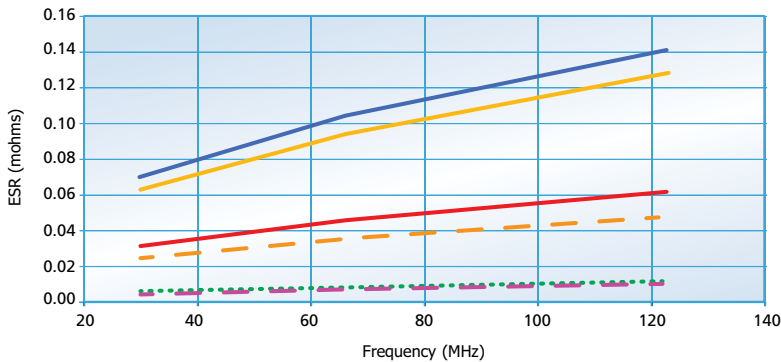

- 4040 56pF
- 4040 18pF
- ... 2225 2.2nF
- 2225 39pF
- 2225 10pF
- - - 4040 5.1nF

ESR Measurement

All ESR figures are measured using a VNA and 2m copper resonant tube and extrapolating to 30MHz by ratio. Measured data can be supplied on request. Measurement of ESR can vary with test method and components should only be compared when tested back-to-back on the same equipment under controlled conditions.

Applications

- MRI / NMR Systems
- Radios / Jammers
- Power Amplifiers
- Radar
- Avionics Instrumentation
- Test Equipment

Characteristics

- Precision machined design. US Patent No. 8,248,198
- 7mm high in SMD, Vertical SMD and thru-hole versions
- Nominal values of 32 to 118nH, 2 to 7 turns
- Q as high as 121 @ 100MHz, SRF 0.7 to 1.2GHz
- Superb shock, vibration and thermal tolerances
- -40°C to +85°C
- Customized version requests welcomed

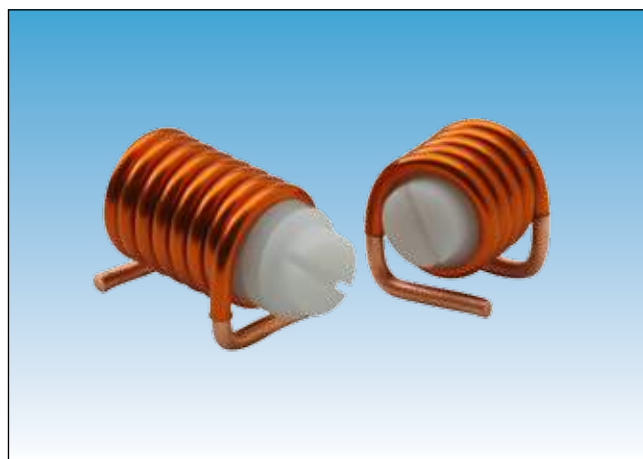

	Part No.	L (nH)				Q (@ 100MHz)	SRF (GHz)	Turns	Thread (mm)
		Min	Nom	Max	No Core				
Surface Mount - Horizontal	JLC02E030TRSM	32	33	34	39	90	1.2	2	6
	JLC03E048TRSM	46	49	52	59	95	1	3	6
	JLC04E065TRSM	60	64	68	78	101	0.9	4	6
	JLC05E088TRSM	74	81	87	99	114	0.9	5	8
	JLC06E110TRSM	94	107	119	123	119	0.7	6	8
	JLC07E130TRSM	104	118	133	142	121	0.7	7	10
	JLC09E160TRSM	122	139	170	191	162	0.58	9	13
	JLC13E250TRSM	185	219	270	294	199	0.43	13	18
	JLC19E375TRSM	281	345	436	457	171	0.31	19	25
	Part No.	L (nH)				Q (@ 100MHz)	SRF (GHz)	Turns	Thread (mm)
		Min	Nom	Max	No Core				
Surface Mount - Vertical	JLC02E030TRVSM	32	33	34	39	90	1.2	2	6
	JLC03E048TRVSM	46	49	52	59	95	1	3	6
	JLC04E065TRVSM	60	64	68	78	101	0.9	4	6
	JLC05E088TRVSM	74	81	87	99	114	0.9	5	8
	JLC06E110TRVSM	94	107	119	123	119	0.7	6	8
	JLC07E130TRVSM	104	118	133	142	121	0.7	7	10
	JLC07E130TRVSM	104	118	133	142	121	0.7	7	10
	Part No.	L (nH)				Q (@ 100MHz)	SRF (GHz)	Turns	Thread (mm)
		Min	Nom	Max	No Core				
Thru Hole Mount - Vertical	JLC02E030TRVPC	32	33	34	39	90	1.2	2	6
	JLC03E048TRVPC	46	49	52	59	95	1	3	6
	JLC04E065TRVPC	60	64	68	78	101	0.9	4	6
	JLC05E088TRVPC	74	81	87	99	114	0.9	5	8
	JLC06E110TRVPC	94	107	119	123	119	0.7	6	8
	JLC07E130TRVPC	104	118	133	142	121	0.7	7	10
	JLC07E130TRVPC	104	118	133	142	121	0.7	7	10

Due to the severe non-magnetism requirements in the magnetic resonance industries, we use only high purity metals that exhibit no measurable magnetism. Commercial brass is simply not acceptable for these applications. Our strict traceability and testing regimes insure this essential parameter.

We can offer sizes, styles and lengths beyond those shown in the tables below – such as Cheese Head, Round Head and Set Screws. We also offer flat washers to complete your needs.

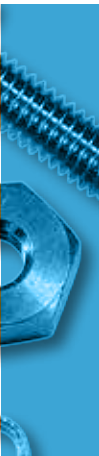

Pan Head

2-56 Thread	
48-109	5/64"
48-107	3/32"
48-105	3/16"
48-100	1/25"
48-106	5/16"
48-101	3/8"
48-102	1/2"
48-101	5/8"
48-104	3/4"
48-108	1"
48-500	Hex Nut
4-40 Thread	
48-115	3/16"
48-110	1/4"
48-116	5/16"
48-111	3/8"
48-112	1/2"
48-117	5/8"
48-113	3/4"
48-114	1"
48-118	2"
48-501	Hex Nut
6-32 Thread	
48-120	1/4"
48-124	3/16"
48-121	3/8"
48-122	1/2"
48-123	3/4"
48-125	1"
48-502	Hex Nut
8-32 Thread	
48-130	1/4"
48-131	3/8"
48-132	1/2"
48-133	3/4"
48-503	Hex Nut
10-32 Thread	
48-140	1/4"
48-141	3/8"
48-142	1/2"
48-143	5/8"
48-144	3/4"
48-145	1"
48-505	Hex Nut
1/4-20 Thread	
48-150	3/8"
48-152	1/2"
48-151	1"
48-153	1-1/4"
48-506	Hex Nut

M2 x .4 Thread	
48-300	6mm
48-301	12mm
48-302	16mm
48-600	Hex Nut
M2.5 x .45 Thread	
48-310	8mm
48-601	Hex Nut
M3 x .5 Thread	
48-320	5mm
48-321	6mm
48-322	7.5mm
48-323	8mm
48-324	10mm
48-325	12mm
48-326	16mm
48-327	20mm
48-602	Hex Nut
M4 x .7 Thread	
48-330	8mm
48-331	10mm
48-332	12mm
48-333	16mm
48-334	20mm
48-335	25mm
48-603	Hex Nut
M5 x .8 Thread	
48-340	8mm
48-341	10mm
48-342	12mm
48-343	16mm
48-344	20mm
48-345	25mm
48-604	Hex Nut

Countersunk Flat Head

2-56 Thread	
48-205	9/64"
48-203	3/16"
48-200	1/4"
48-204	3/8"
48-201	1/2"
48-202	1"
48-500	Hex Nut
4-40 Thread	
48-210	1/4"
48-216	5/16"
48-211	3/8"
48-212	1/2"
48-213	3/4"
48-214	1"
48-215	1-1/4"
48-501	Hex Nut
6-32 Thread	
48-220	1/4"
48-221	3/8"
48-228	7/16"
48-222	1/2"
48-223	3/4"
48-224	1"
48-225	1-1/4"
48-229	1-3/8"
48-226	1-1/2"
48-227	1-3/4"
48-502	Hex Nut
8-32 Thread	
48-230	3/8"
48-231	1/2"
48-232	5/8"
48-233	3/4"
48-503	Hex Nut
10-32 Thread	
48-240	3/8"
48-241	1/2"
48-242	5/8"
48-243	3/4"
48-244	1"
48-245	1-1/4"
48-505	Hex Nut
1/4-20 Thread	
48-250	3/4"
48-506	Hex Nut

M2 x .4 Thread	
48-400	5mm
48-401	10mm
48-600	Hex Nut
M3 x .5 Thread	
48-415	6mm
48-410	8mm
48-411	10mm
48-412	12mm
48-413	16mm
48-414	20mm
48-602	Hex Nut
M4 x .7 Thread	
48-420	8mm
48-421	10mm
48-422	12mm
48-423	16mm
48-424	20mm
48-603	Hex Nut
M5 x .8 Thread	
48-430	8mm
48-431	10mm
48-432	12mm
48-433	16mm
48-434	20mm
48-435	25mm
48-604	Hex Nut

Coils also require inserts, pins and other special shapes that are custom-designed to the customer's specific requirements. The ability to quickly and precisely supply custom designs is part of our heritage and we are eager to sample our high quality hardware based on your requirements. As with the fasteners, we use only high purity metals that exhibit no measurable magnetism.

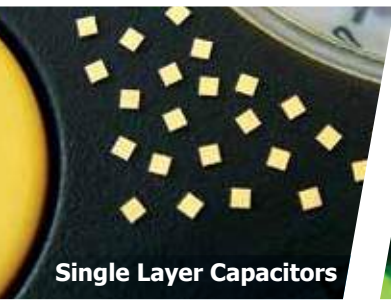

Single Layer Capacitors



Pulse Capacitors



StackiCap™ Capacitors

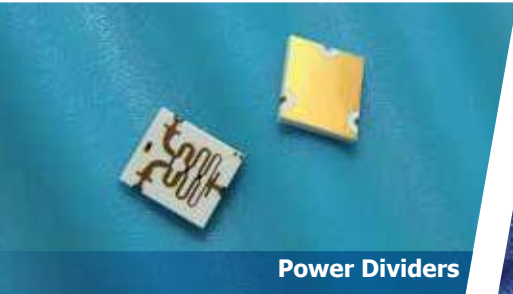

Power Dividers

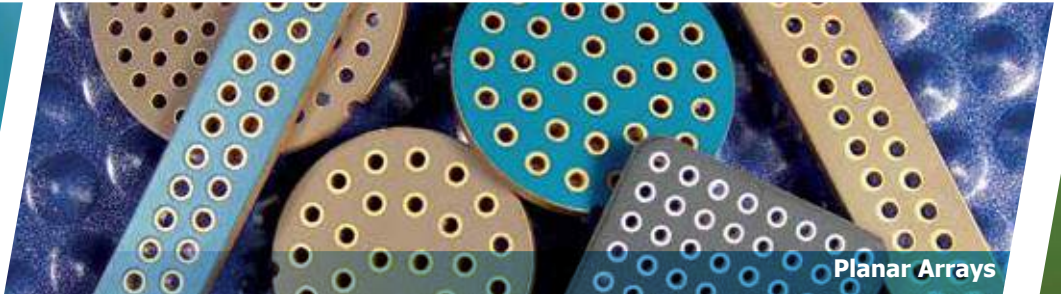

Planar Arrays



Broadband Blocking Capacitors



Feedthrough EMI Filters

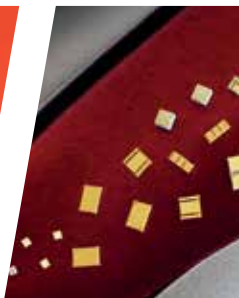

Gain Equalizers



Specialty Products



X2Y 3 terminal EMI chips

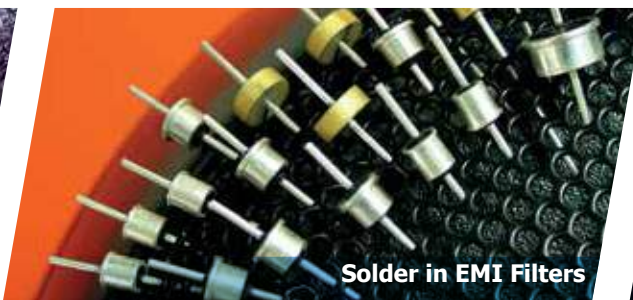

Solder in EMI Filters



Pulse Power Ca

Other products available



Hi-Rel Products

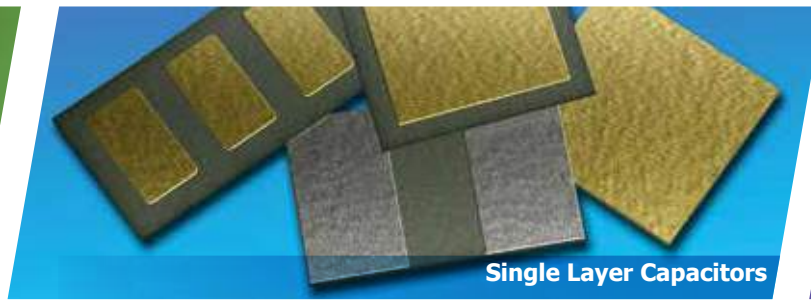

Single Layer Capacitors

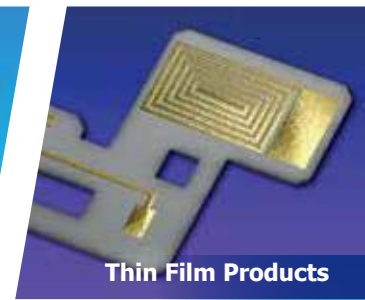

Thin Film Products



Ultra Low ESR Capacitors

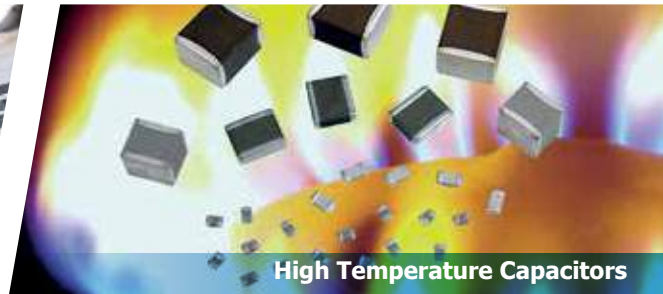

High Temperature Capacitors

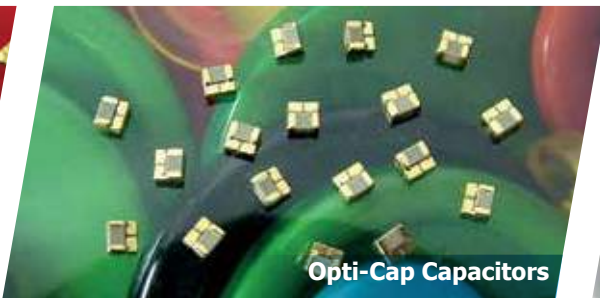

Opti-Cap Capacitors



Safety Certified Capacitors

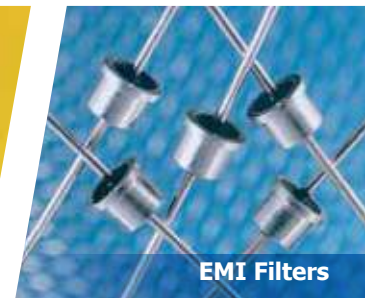

EMI Filters

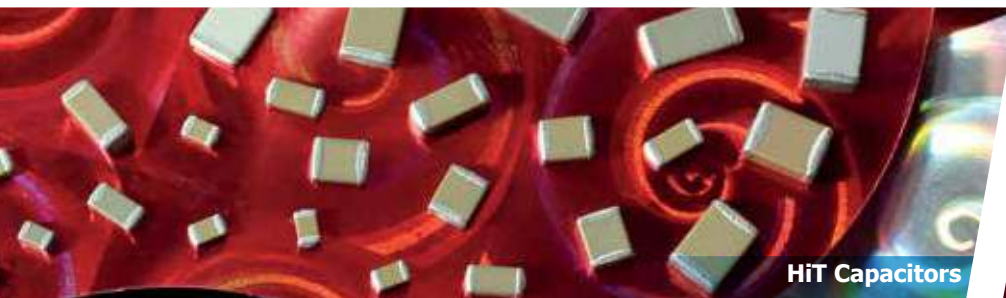

HiT Capacitors

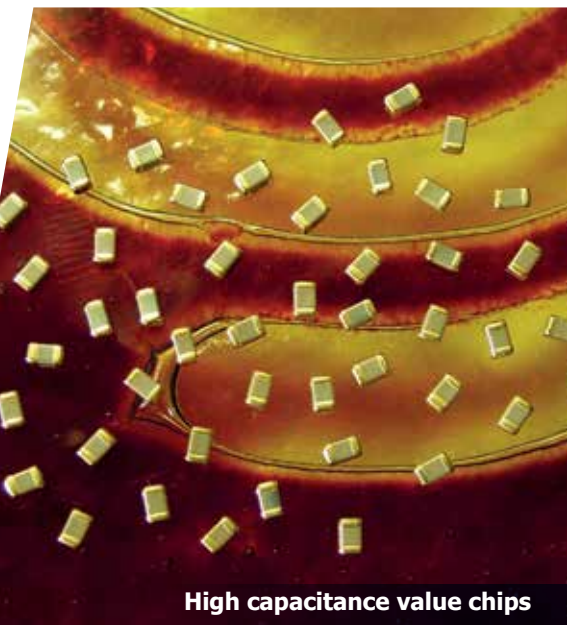

High capacitance value chips



capacitors



Radial Leaded Capacitors

from

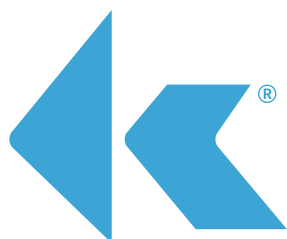

knowles

PRECISION DEVICES

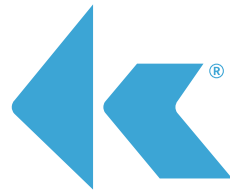

PRECISION DEVICES
knowles

**COMPEX • DLI • JOHANSON MFG
NOVACAP • SYFER • VOLTRONICS**

Asian Sales Office

O: +86 512 62588258

F: +86 512 62589258

KPD-Asia-sales@knowles.com

European Sales Office

O: +44 1603 723300

F: +44 1603 723301

KPD-Europe-sales@knowles.com

North American Sales Office

O: +1 661 295 5920

F: +1 661 295 5928

O: +1 315 655 8710

F: +1 315 655 0445

KPD-NA-sales@knowles.com

Looking for pricing, stock, or lifecycle information?

Click below to explore more details on WIN SOURCE:

- [⊖ View JR200 on WIN SOURCE](#)
- [⊖ Knowles Voltronics Information](#)

Optimize Your Supply Chain with WIN SOURCE Solutions

- ✓ Global Sourcing Solution
- ✓ Obsolete Management
- ✓ Cost Control Management
- ✓ Shortage Management
- ✓ Alternative Solution
- ✓ Excess Inventory Management