



**THE DATASHEET OF  
AC0805JR-0733KL**



# TVB1440 4-Channel Video Re-Driver with Equalization

ECCN: 3E991

## 1 Features

- Compatible with TV Aggregated Video Signaling Electricals
- Compatible to FPD Link 2 Interface
- Suited for Digital TV Chipset and TCON Boards
- Quad Channel Re-Driver Supporting Data Rates from 600 Mbps to 5 Gbps
- 3.3 V and 1.1 V Supply for Low Power Operation
- 175 mW Active Power Consumption for 4 Lane Operation
- 2 mW Shutdown Power
- Highly Configurable Input Equalization with 8 Control Settings
  - 0 dB to 15 dB
- 4 Pre-Emphasis Control Settings
  - 0, 3, 6 and 9 dB
- 4 Output Voltage Swing Control Settings
  - 350, 500, 700 and 1000 mV
- I<sup>2</sup>C Control to Configure the Device for Optimum Performance
- Extended Temperature Range of -40°C to 85°C
- 2 kV HBM and 500 V CDM ESD Protection
- 48-pin QFN 7 mm x 7 mm package.

## 2 Applications

- Digital Television
- Camera
- Video Interfaces Requiring Large Throughputs

## 4 Simplified Schematics

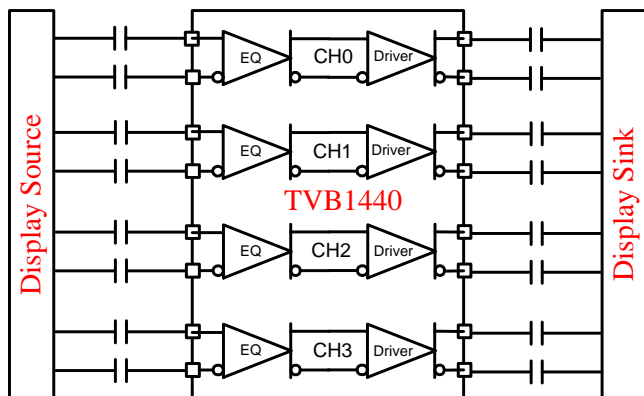

## 3 Description

TVB1440 is a 4 channel re-driver signal conditioner for TV applications allowing signal integrity between TV chipset and TCON boards. I<sup>2</sup>C control provides the wide ranges of flexibility to configure the device for optimal signal conditioning so that video data link between a source and sink can achieve high fidelity. TVB1440 allows larger distance between a video source and sink device through its excellent jitter cleaning capability.

It has selectable control for receive equalization accessible through I2C to compensate for large trace or cable loss at its input resulting improved eye at the output signals. Transmitter in each channel has 4 levels of pre-emphasis and 4 levels of output voltage swing settings which enable optimum video signal performance from the TVB1440 to downstream receiver.

The TVB1440 is optimized for power conscience applications. Apart from its low active power, TVB1440 contains activity detection circuitry on the data link input that transitions to a low-power output disable mode in the absence of a valid input signal. This activity detect circuit can be disabled if desired. The device also has a shutdown mode when exercised results in 2mW.

### Device Information<sup>(1)</sup>

PART NUMBER	PACKAGE	BODY SIZE (NOM)
TVB1440	VQFN (48)	7.00 mm x 7.00 mm

(1) For all available packages, see the orderable addendum at the end of the datasheet.

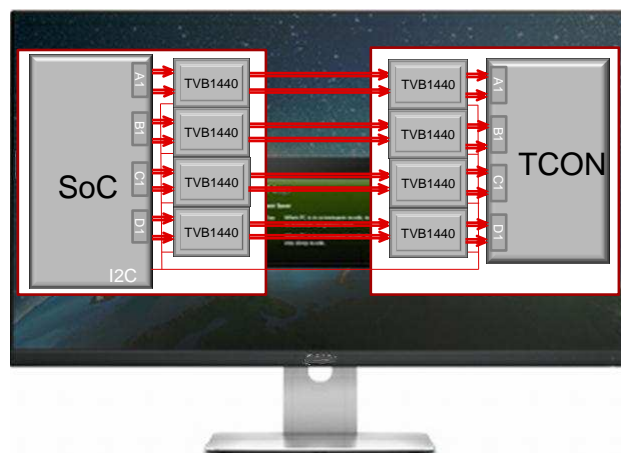

## Table of Contents

<b>1 Features</b> .....	1	8.3 Feature Description.....	9
<b>2 Applications</b> .....	1	8.4 Device Functional Modes.....	9
<b>3 Description</b> .....	1	8.5 Programming.....	9
<b>4 Simplified Schematics</b> .....	1	8.6 Register Maps .....	13
<b>5 Revision History</b> .....	2	<b>9 Application and Implementation</b> .....	14
<b>6 Pin Configuration and Functions</b> .....	3	9.1 Application Information.....	14
<b>7 Specifications</b> .....	4	<b>10 Power Supply Recommendations</b> .....	19
7.1 Absolute Maximum Ratings .....	4	10.1 Power-Up Sequence .....	19
7.2 Handling Ratings .....	4	10.2 Power-Down Sequence .....	19
7.3 Recommended Operating Conditions.....	4	<b>11 Layout</b> .....	20
7.4 Thermal Information .....	5	11.1 Layout Guidelines .....	20
7.5 Electrical Characteristics.....	5	<b>12 Device and Documentation Support</b> .....	22
7.6 Timing Requirements .....	5	12.1 Trademarks .....	22
7.7 Switching Characteristics .....	6	12.2 Electrostatic Discharge Caution.....	22
7.8 Typical Characteristics.....	7	12.3 Export Control Notice.....	22
<b>8 Detailed Description</b> .....	8	12.4 Glossary .....	22
8.1 Overview .....	8	<b>13 Mechanical, Packaging, and Orderable Information</b> .....	22
8.2 Functional Block Diagram .....	8		

## 5 Revision History

### Changes from Original (November 2014) to Revision A

Page

- Changed text in the *Package Specific* section From: "The TVB1440 package has a 5.6 mm x 5.6 mm thermal pad."  
To: "The TVB1440 package has a 4.1 mm x 4.1 mm thermal pad." .....

21

## 6 Pin Configuration and Functions

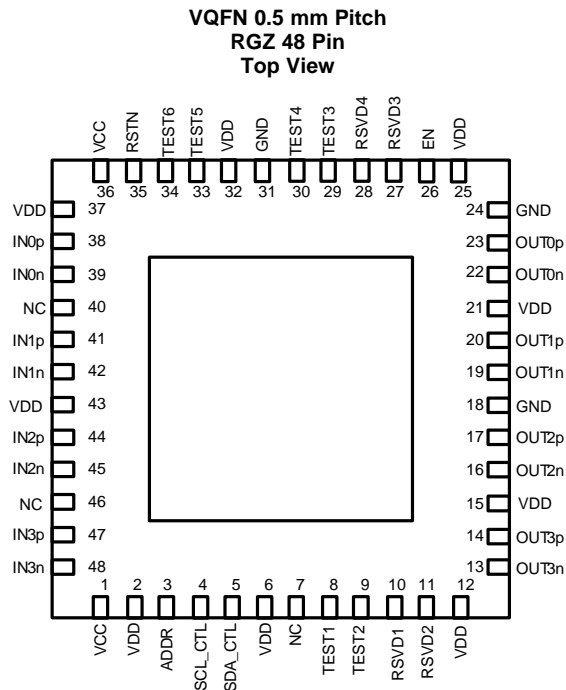

### Pin Functions

PIN			DESCRIPTION
SIGNAL	NO.	I/O	
<b>DATA LANES PINS</b>			
IN0p, IN0n	38, 39	Input (100Ω diff)	Lane 0 Differential Input
IN1p, IN1n	41, 42		Lane 1 Differential Input
IN2p, IN2n	44, 45		Lane 2 Differential Input
IN3p, IN3n	47, 48		Lane 3 Differential Input
OUT0p, OUT0n	23, 22	Output (100Ω diff)	Lane 0 Differential Output
OUT1p, OUT1n	20, 19		Lane 1 Differential Output
OUT2p, OUT2n	17, 16		Lane 2 Differential Output
OUT3p, OUT3n	14, 13		Lane 3 Differential Output
<b>CONTROL PINS</b>			
ADDR	3	3-level Input	I <sup>2</sup> C Target Address Select.
EN	26	I	Device Enable. This input incorporates internal pullup of 200 kΩ.
NC	7, 40, 46		No Connect. These terminals may be left un-connected, or connect to GND.
RSTN	35	I	Active Low Device Reset. This is 1.1V input. This input includes a 150kΩ resistor to the V <sub>DD</sub> core supply. An external capacitor to GND is recommended on the RSTN input to provide a power-up delay. This signal is used to place the TVB1440 into Shutdown mode for the lowest power consumption. When the RSTN input is asserted, all outputs are high-impedance, and inputs are ignored; all I <sup>2</sup> C registers are reset to their default values. At power up, the RSTN input must not be de-asserted until the V <sub>CC</sub> and V <sub>DD</sub> supplies have reached at least the minimum recommended supply voltage level.
RSVD1	10	I	Reserved pins. Please connect the pin to GND through 1K resistor.
RSVD2	11	I	Reserved pins. Please connect the pin to VCC through 1K resistor.
RSVD3	27	I	Reserved pins. Please connect the pin to VCC through 1K resistor.
RSVD4	28	I	Reserved pins. Please connect the pin to GND through 1K resistor.
SCL_CTL SDA_CTL	4 5	I/O	Bidirectional I2C interface to configure TVB1440. This interface is active independent of EN input but inactive when RSTN is low.
TEST1-6	8, 9, 29, 30, 33, 34		Test Outputs. Do not connect.

**TVB1440**

SLASE51A –NOVEMBER 2014–REVISED NOVEMBER 2014

www.ti.com

**Pin Functions (continued)**

PIN			DESCRIPTION
SIGNAL	NO.	I/O	
<b>SUPPLY AND GROUND PINS</b>			
GND	18, 24, 31, PAD		Ground. Reference GND connections include the device package exposed thermal pad.
VDD	2, 6, 12, 15, 21, 25, 32, 37, 43		Low voltage supply for analog and digital core. Nominally 1.1V
VCC	1, 36		3.3V Supply

**7 Specifications****7.1 Absolute Maximum Ratings**over operating free-air temperature range (unless otherwise noted) <sup>(1)</sup>

		MIN	MAX	UNIT
Supply voltage	VCC	-0.3	4	V
	VDD	-0.3	1.3	
Voltage range	HS Link I/O (OUTx, INx) Differential Voltage	-0.3	1.3	V
	RSTN	-0.3	1.3	
	SCL_CTL, SDA_CTL, ADDR, EN	-0.3	4	

(1) Stresses beyond those listed under *Absolute Maximum Ratings* may cause permanent damage to the device. These are stress ratings only, which do not imply functional operation of the device at these or any other conditions beyond those indicated under *Recommended Operating Conditions*. Exposure to absolute-maximum-rated conditions for extended periods may affect device reliability.

**7.2 Handling Ratings**

		MIN	MAX	UNIT
T <sub>STG</sub>	Storage temperature range	-65	150	-C
Electrostatic discharge	Human body model (HBM) <sup>(1)</sup>	-2000	2000	V
	Charged-device model (CDM) <sup>(2)</sup>	-500	500	

(1) JEDEC document JEP155 states that 500-V HBM allows safe manufacturing with a standard ESD control process.

(2) JEDEC document JEP157 states that 250-V CDM allows safe manufacturing with a standard ESD control process.

**7.3 Recommended Operating Conditions**

over operating free-air temperature range (unless otherwise noted)

		MIN	TYP	MAX	UNIT
VCC	Supply Voltage, IO	3		3.6	V
VDD	Supply Voltage, CORE	1		1.26	V
V <sub>IH</sub>	High-level input voltage for ADDR, EN	1.9		3.6	V
V <sub>IL</sub>	Low-level input voltage for ADDR, EN	0		0.8	V
V <sub>IH,RSTN</sub>	High-level input voltage for RSTN (typical hysteresis of 80mV)		0.75		V
V <sub>IL,RSTN</sub>	Low-level input voltage for RSTN (typical hysteresis of 80mV)		0.3		V
T <sub>A</sub>	Operating free-air temperature	0		85	°C
f <sub>scl</sub>	I2C CK frequency at SCL_CTL (standard I2C mode <sup>(1)</sup> )			100	kHz

(1) The local interface through SCL\_CTL and SDA\_CTL should follow standard mode I2C specifications

## 7.4 Thermal Information

THERMAL METRIC <sup>(1)</sup>		TVB1440	UNIT
		RGZ (48 Pin)	
R <sub>θJA</sub>	Junction-to-ambient thermal resistance	35.1	°C/W
R <sub>θJC(top)</sub>	Junction-to-case (top) thermal resistance	21.5	
R <sub>θJB</sub>	Junction-to-board thermal resistance	11.7	
Ψ <sub>JT</sub>	Junction-to-top characterization parameter	1.2	
Ψ <sub>JB</sub>	Junction-to-board characterization parameter	11.9	
R <sub>θJC(bot)</sub>	Junction-to-case (bottom) thermal resistance	6.7	

(1) For more information about traditional and new thermal metrics, see the *IC Package Thermal Metrics* application report, [SPRA953](#).

## 7.5 Electrical Characteristics

over operating free-air temperature range (unless otherwise noted)

PARAMETER		MIN	TYP	MAX	UNIT
I <sub>CC</sub>	Supply current 4 lanes operation <sup>(1)</sup>		130	230	mA
I <sub>STDN</sub>	Shutdown supply current <sup>(1)</sup>		1.5	3	mA
I <sub>OD</sub>	Squelch (output disable) supply current		35	50	mA
V <sub>OD0</sub>	Output differential voltage swing	238	340	442	mVpp
V <sub>OD1</sub>		357	510	663	
V <sub>OD2</sub>		484	690	897	
V <sub>OD3</sub>		700	1000	1300	
PE <sub>0</sub>	Output pre-emphasis		0		dB
PE <sub>1</sub>			3		
PE <sub>2</sub>			6		
PE <sub>3</sub>			9		
R <sub>OUT</sub>	Driver output impedance		50		Ω
I <sub>(TXSHORT)</sub>	Output pins short circuit current limit			50	mA
V <sub>(SQUELCH)</sub>	Squelch threshold voltage for input signals (default)		80		mVpp

(1) Values are V<sub>DD</sub> supply measurements; V<sub>CC</sub> supply measurements are 5 mA (typical) and 8 mA (max), with zero current in shutdown mode.

## 7.6 Timing Requirements

		MIN	TYP	MAX	UNIT
t <sub>ramp1</sub>	Time V <sub>DD</sub> must stable before V <sub>CC</sub> is applied	10			μS
t <sub>ramp2</sub>	Time RSTN must remain asserted until V <sub>CC</sub> /V <sub>DD</sub> voltage has reached minimum recommended operation	100			μS
t <sub>ramp3</sub>	Time device will be available for operation after a valid reset	400			mS

**TVB1440**

SLASE51A –NOVEMBER 2014–REVISED NOVEMBER 2014

www.ti.com

**7.7 Switching Characteristics**

over operating free-air temperature range (unless otherwise noted)

PARAMETER		MIN	TYP	MAX	UNIT
$t_{PD}$	Propagation delay time		300		ps
$t_{sk1}$	Intra-pair output skew (Figure 1)			20	ps
$t_{sk2}$	Inter-pair output skew (Figure 1)			100	ps
$\Delta t_{jit}$	Total peak-to-peak residual jitter $V_{OD0}$ ; $PE_0$ ; $EQ = 8dB$ ; clean source; minimum input and output cabling; PRBS7 data pattern.			15	ps
$t_{sq\_enter}$	Squelch entry time Time from a loss of valid input signal to ML output off	10		120	$\mu S$
$t_{sq\_exit}$	Squelch exit time Time from valid input signal available while in squelch mode to ML outputs on			1	$\mu S$

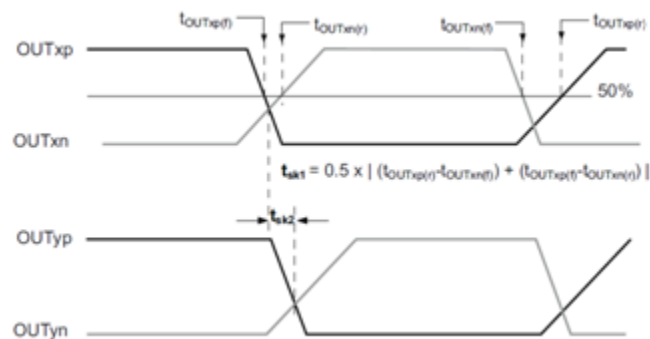
**Figure 1. Output Skew Definitions**

## 7.8 Typical Characteristics

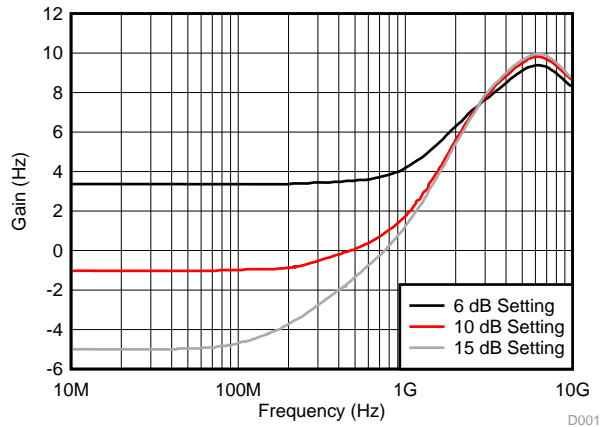

Figure 2. Typical EQ Gain Curves (simulations)

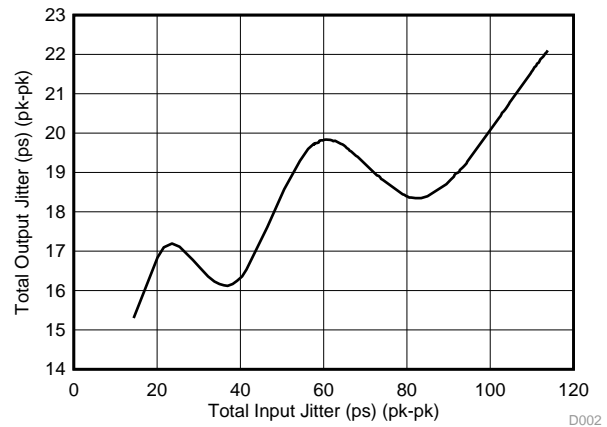

Figure 3. Jitter Performance with Optimal EQ Settings

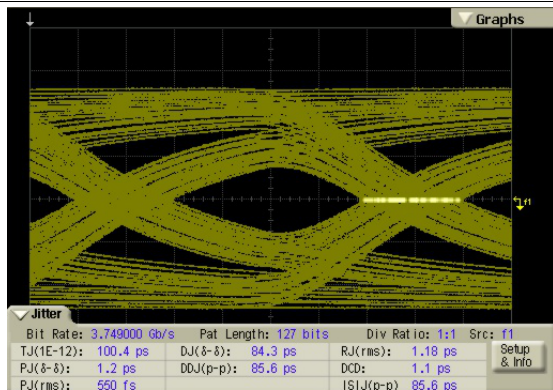

Figure 4. 3.75-Gbps Input With 20 Inch Trace

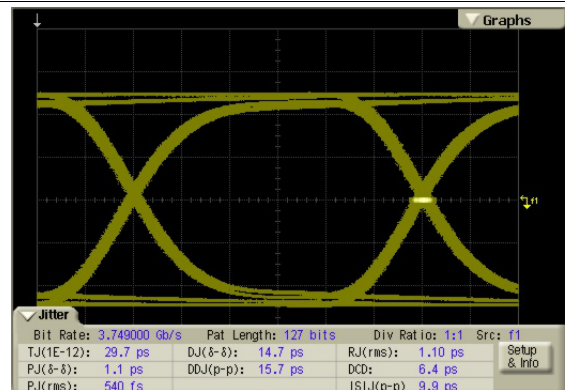

Figure 5. 3.75-Gbps Output with 20 Inch Input Trace and 8-dB EQ Setting

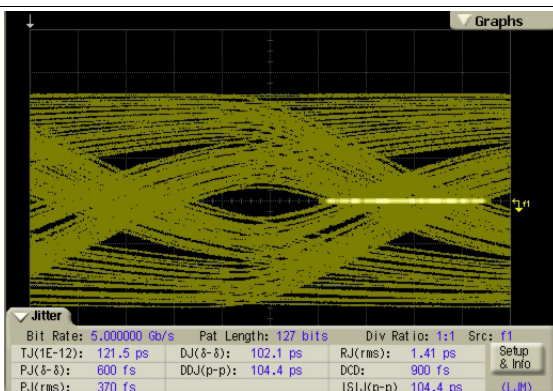

Figure 6. 5-Gbps Input with 20 Inches Trace

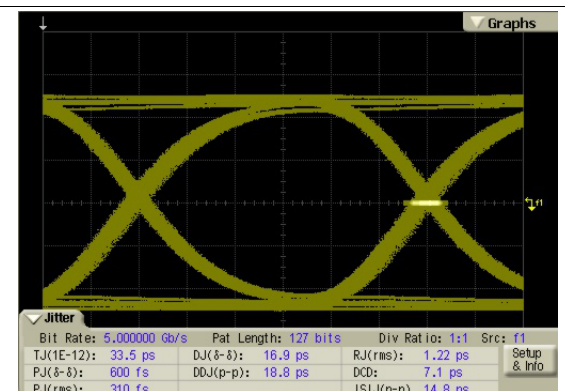

Figure 7. 5-Gbps Output with 20 Inch Input Trace and 13-dB EQ Setting

**TVB1440**

SLASE51A –NOVEMBER 2014–REVISED NOVEMBER 2014

www.ti.com

## 8 Detailed Description

### 8.1 Overview

TVB1440 is a 4 channel HS re-driver signal conditioner for TV applications. I2C control provides the wide ranges of flexibility to configure the device for optimal signal conditioning so that video data link between a source and sink can achieve high fidelity. TVB1440 allows larger distance between a Chipset and TCON boards through its excellent jitter cleaning capability.

The TVB1440 is optimized for power conscience applications. Apart from its low active power, TVB1440 contains activity detection circuitry on the data link input that transitions to a low-power output disable mode in the absence of a valid input signal. This activity detect circuit can be disabled if desired. The device also has a shutdown mode when exercised results in 2 mW.

The TVB1440 receiver and driver provide input and output common mode voltage bias. It is required that both receive and transmit end of the device is ac coupled in application use cases. Suggested value for the ac coupling capacitors is 75-200 nF.

### 8.2 Functional Block Diagram

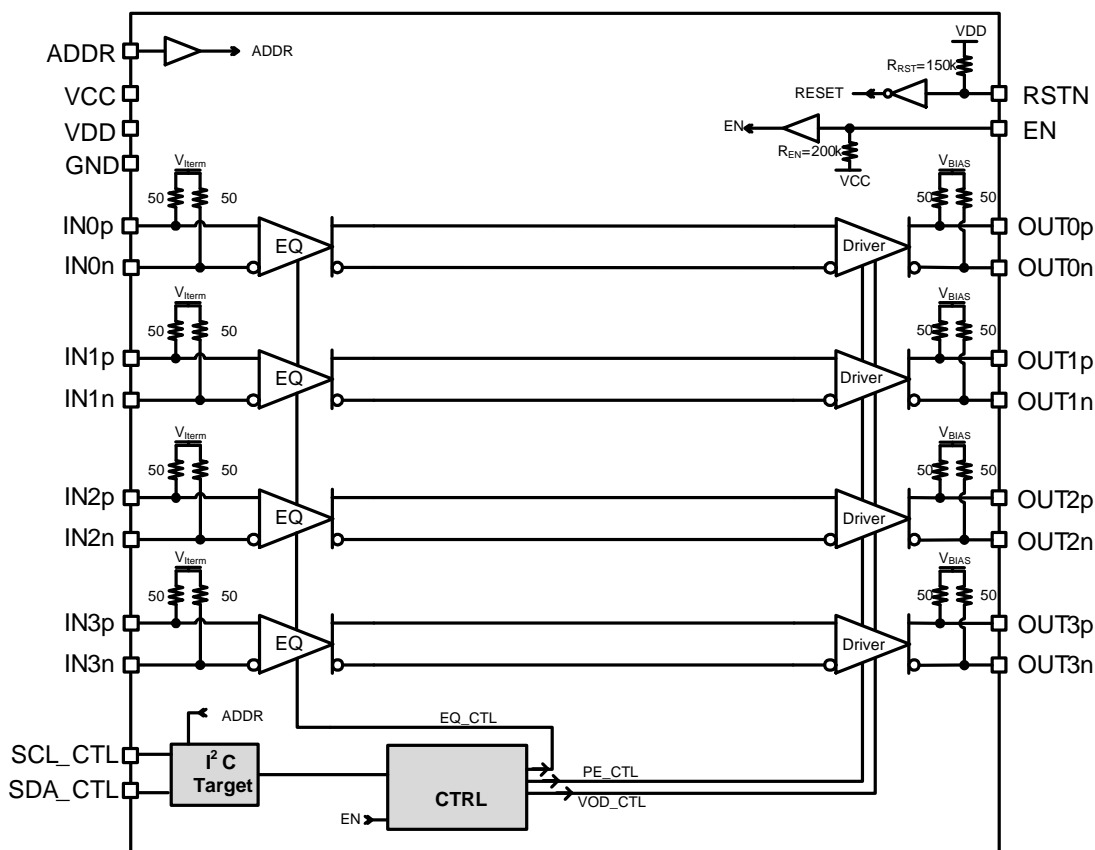

## 8.3 Feature Description

### 8.3.1 Equalization

TVB1440 provides flexible continuous time linear equalization (CTLE) to compensate for large trace or cable loss at its input resulting improved eye at the output signals. It has selectable control for receive equalization accessible through I<sup>2</sup>C.

### 8.3.2 Configurable Output

Transmitter in each channel has 4 levels of pre-emphasis and 4 levels of output voltage swing settings which enable optimum video signal performance from the TVB1440 to downstream receiver.

### 8.3.3 Squelch

TVB1440 has active Squelch feature that allows automatic shutdown of output drivers when it does not have valid input signal. The feature can be disabled through I<sup>2</sup>C if not desired.

## 8.4 Device Functional Modes

### 8.4.1 Active Mode

Normal operation mode. The data lanes of TVB1440 work normally.

### 8.4.2 Shutdown Mode

Device is in lowest power mode. This mode is invoked by de-asserting RSTN or EN low.

### 8.4.3 Squelch Mode

The device does not have valid input signal. Output drivers are turned off.

## 8.5 Programming

### 8.5.1 Local I<sup>2</sup>C Interface

It is required to use the TVB1440's local I<sup>2</sup>C interface to configure the TVB1440's receivers (IN[3:0]P/N) and transmitters (OUT[3:0]P/N). The TVB1440's internal registers are accessed through the SCL\_CTL pin and SDA\_CTL pin. The 7-bit I<sup>2</sup>C slave address of the TVB1440 is determined by the ADDR pin.

**Table 1. TVB1440 I<sup>2</sup>C Slave Address Options**

ADDR	7-BIT I <sup>2</sup> C SLAVE ADDRESS	READ SLAVE ADDRESS	WRITE SLAVE ADDRESS
Low (VIL)	7'b0101100	'h59	'h58
V <sub>CC</sub> /2 (VIM)	7'b0101101	'h5B	'h5A
High (VIH)	7'b0101110	'h5D	'h5C

Before adjusting the TVB1440's registers, a writing a zero to bit 2 of address 04h is required to enable the receiver and transmitter adjustments.

**TVB1440**

SLASE51A –NOVEMBER 2014–REVISED NOVEMBER 2014

[www.ti.com](http://www.ti.com)**8.5.2 Receiver (IN[3:0]P/N) Adjustments****8.5.2.1 Equalization Level**

It is recommended to use the TVB1440 local I<sup>2</sup>C interface to configure the TVB1440 receiver equalization level. Software should then enable equalization control by writing a one to EQ\_I2C\_ENABLE bit (bit 7 at address 05h). After EQ\_I2C\_ENABLE is set, then software can program the equalization for each lane (IN[3:0]) to the appropriate value. Refer to [Table 2](#) for details on equalization settings for each lane.

**Table 2. TVB1440 Equalization Levels**

Address	Bits(s)	Description	Access
04h	2	Receiver and transmitter adjustment. 0 – configure receiver and transmitter using I2C (required) 1 – reserved (default)	RW
05h	2:0	EQ_LEVEL_LANE0. This field selects the EQ gain level for Lane 0 (IN0P/N). 000 – 0 dB 001 – 2 dB (3.75Gbps); 2.5 dB (5Gbps) 010 – 3.5 dB (3.75Gbps); 5 dB (5Gbps) 011 – 5 dB (3.75Gbps); 6 dB (5Gbps) 100 – 6.5 dB (3.75Gbps); 8 dB (5Gbps) 101 – 8 dB (3.75Gbps); 11 dB (5Gbps) 110 – 9.5 dB (3.75Gbps); 13 dB (5Gbps) 111 – 12 dB (3.75Gbps); 15 dB (5Gbps)	RW
05h	7	EQ_I2C_ENABLE. This field allows EQ control through I2C 0 – reserved (default) 1 – EQ level is set by I2C (required)	RW
07h	2:0	EQ_LEVEL_LANE1. This field selects the EQ gain level for Lane 1 (IN1P/N). Bit definition identical to that of EQ_LEVEL_LANE0.	RW
09h	2:0	EQ_LEVEL_LANE2. This field selects the EQ gain level for Lane 2 (IN2P/N). Bit definition identical to that of EQ_LEVEL_LANE0.	RW
0Bh	2:0	EQ_LEVEL_LANE3. This field selects the EQ gain level for Lane 3 (IN3P/N). Bit definition identical to that of EQ_LEVEL_LANE0.	RW

**8.5.2.2 Squelch Level**

The TVB1440 squelch level defaults to 80mVpp. If it is necessary to adjust the squelch level, it can be done by changing the SQUELCH\_SENSITIVITY register located in the TVB1440's Local I2C register space.

**Table 3. Squelch Sensitivity Levels**

Address	Bits(s)	Description	Access
03h	5:4	SQUELCH_SENSITIVITY. Main link squelch sensitivity is selected by this field, and determines the transitions to and from the Output Disable mode. 00 – Main Link IN0P/N squelch detection threshold is set to 40mVpp. 01 – Main Link IN0P/N squelch detection threshold is set to 80mVpp. (Default) 10 – Main Link IN0P/N squelch detection threshold is set to 160mVpp. 11 – Main Link IN0P/N squelch detection threshold is set to 250mVpp.	RW
	3	SQUELCH_ENABLE. 0 – Main Link IN0P/N squelch detection is enabled (default) 1 – Main Link IN0P/N squelch detection is disabled.	RW

### 8.5.3 Main Link Output [OUT[3:0]P/N] Adjustments

The TVB1440 Main link outputs (OUT[3:0]) must be set in link address space by following specified I<sup>2</sup>C access method.

#### 8.5.3.1 LINK Address Space

Access to and from the TVB1440 LINK address space is indirectly addressable through the local I<sup>2</sup>C registers as illustrated in the [Figure 8](#).

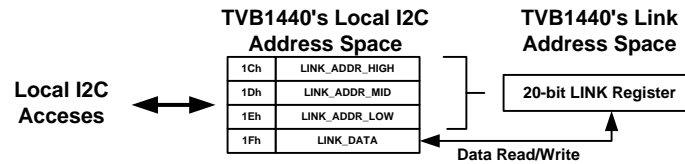

**Figure 8. Accessing TVB1440 LINK Registers**

The configuration of these registers can be performed through the local I<sup>2</sup>C interface, where three registers (from 1Ch to 1Eh) are used as the address to the LINK register and another one (1Fh) as a data to be read/written.

**TVB1440**

SLASE51A –NOVEMBER 2014–REVISED NOVEMBER 2014

www.ti.com

**8.5.4 Example Script**

The script below is for a Total Phase Aardvark I<sup>2</sup>C controller. Details on the Total Phase Aardvark I<sup>2</sup>C controller can be obtained from the [Total Phase website](#). This example is for a 5.0 Gbps data rate with 4 active lanes.

```

<aardvark>
<configure i2c="1" spi="1" gpio="0" tpower="1" pullups="0"/>
<i2c_bitrate khz="100"/>

====Program the device====
<i2c_write addr="0x2D" count="1" radix="16">04 00</i2c_write> />

====Program Link Bandwidth Settings to 5Gbps====LINK 00100h====
<i2c_write addr="0x2D" count="1" radix="16">1C 00</i2c_write> />
<i2c_write addr="0x2D" count="1" radix="16">1D 01</i2c_write> />
<i2c_write addr="0x2D" count="1" radix="16">1E 00</i2c_write> />
<i2c_write addr="0x2D" count="1" radix="16">1F 14</i2c_write> />

====Program Num of Lanes to 4.s====LINK 00101h====
<i2c_write addr="0x2D" count="1" radix="16">1C 00</i2c_write> />
<i2c_write addr="0x2D" count="1" radix="16">1D 01</i2c_write> />
<i2c_write addr="0x2D" count="1" radix="16">1E 01</i2c_write> />
<i2c_write addr="0x2D" count="1" radix="16">1F 04</i2c_write> />

====Program VOD L1 and Pre-Emphasis L0 for Lane 0====LINK 00103h====
<i2c_write addr="0x2D" count="1" radix="16">1C 00</i2c_write> />
<i2c_write addr="0x2D" count="1" radix="16">1D 01</i2c_write> />
<i2c_write addr="0x2D" count="1" radix="16">1E 03</i2c_write> />
<i2c_write addr="0x2D" count="1" radix="16">1F 01</i2c_write> />

====Program VOD L1 and Pre-Emphasis L0 for Lane 1====LINK 00104h====
<i2c_write addr="0x2D" count="1" radix="16">1C 00</i2c_write> />
<i2c_write addr="0x2D" count="1" radix="16">1D 01</i2c_write> />
<i2c_write addr="0x2D" count="1" radix="16">1E 04</i2c_write> />
<i2c_write addr="0x2D" count="1" radix="16">1F 01</i2c_write> />

====Program VOD L1 and Pre-Emphasis L0 for Lane 2====LINK 00105h====
<i2c_write addr="0x2D" count="1" radix="16">1C 00</i2c_write> />
<i2c_write addr="0x2D" count="1" radix="16">1D 01</i2c_write> />
<i2c_write addr="0x2D" count="1" radix="16">1E 05</i2c_write> />
<i2c_write addr="0x2D" count="1" radix="16">1F 01</i2c_write> />

====Program VOD L1 and Pre-Emphasis L0 for Lane 3====LINK 00106h====
<i2c_write addr="0x2D" count="1" radix="16">1C 00</i2c_write> />
<i2c_write addr="0x2D" count="1" radix="16">1D 01</i2c_write> />
<i2c_write addr="0x2D" count="1" radix="16">1E 06</i2c_write> />
<i2c_write addr="0x2D" count="1" radix="16">1F 01</i2c_write> />

====Set Power Mode to Normal====LINK 00600h====
<i2c_write addr="0x2D" count="1" radix="16">1C 00</i2c_write> />
<i2c_write addr="0x2D" count="1" radix="16">1D 06</i2c_write> />
<i2c_write addr="0x2D" count="1" radix="16">1E 00</i2c_write> />
<i2c_write addr="0x2D" count="1" radix="16">1F 01</i2c_write> />

====May want to adjust Squelch Level===
<i2c_write addr="0x2D" count="1" radix="16">03 10</i2c_write> />

====Enable EQ===
<i2c_write addr="0x2D" count="1" radix="16">05 80</i2c_write> />

====Set EQ level to 11dB(5Gbps) for lane 0===
<i2c_write addr="0x2D" count="1" radix="16">05 85</i2c_write> />

====Set EQ level to 11dB(5Gbps) for lane 1===
<i2c_write addr="0x2D" count="1" radix="16">07 05</i2c_write> />

====Set EQ level to 11dB(5Gbps) for lane 2===
<i2c_write addr="0x2D" count="1" radix="16">09 05</i2c_write> />

====Set EQ level to 11dB(5Gbps) for lane 3===
<i2c_write addr="0x2D" count="1" radix="16">0B 05</i2c_write> />
</aardvark>

```

## 8.6 Register Maps

**Table 4. TVB1440 LINK Registers**

LINK Address	NAME	Value Written	Value Read	Description
00100h	LINK_BW_SET	06h	00h	<1.6Gbps per lane
		0Ah	01h	1.6-2.7Gbps per lane
		14h	02h	2.7-5.0Gbps per lane
00101h	LANE_COUNT_SET	00h	00h	All Lanes disabled
		01h	01h	One lane enabled (OUT0).
		02h	03h	Two lanes enabled (OUT[1:0]).
		04h	0Fh	Four lanes enabled (OUT[3:0]).
00103h	LANE0_SET	00h	00h	VOD Level 0 and Pre-emphasis Level 0 for OUT0.
		08h	04h	VOD Level 0 and Pre-emphasis Level 1 for OUT0.
		10h	08h	VOD Level 0 and Pre-emphasis Level 2 for OUT0.
		18h	0Ch	VOD Level 0 and Pre-emphasis Level 3 for OUT0.
		01h	01h	VOD Level 1 and Pre-emphasis Level 0 for OUT0.
		09h	05h	VOD Level 1 and Pre-emphasis Level 1 for OUT0.
		11h	09h	VOD Level 1 and Pre-emphasis Level 2 for OUT0.
		02h	02h	VOD Level 2 and Pre-emphasis Level 0 for OUT0.
		0Ah	06h	VOD Level 2 and Pre-emphasis Level 1 for OUT0.
		03h	03h	VOD Level 3 and Pre-emphasis Level 0 for OUT0
00104h	LANE1_SET	00h	00h	VOD Level 0 and Pre-emphasis Level 0 for OUT1.
		08h	04h	VOD Level 0 and Pre-emphasis Level 1 for OUT1.
		10h	08h	VOD Level 0 and Pre-emphasis Level 2 for OUT1.
		18h	0Ch	VOD Level 0 and Pre-emphasis Level 3 for OUT1.
		01h	01h	VOD Level 1 and Pre-emphasis Level 0 for OUT1.
		09h	05h	VOD Level 1 and Pre-emphasis Level 1 for OUT1.
		11h	09h	VOD Level 1 and Pre-emphasis Level 2 for OUT1.
		02h	02h	VOD Level 2 and Pre-emphasis Level 0 for OUT1.
		0Ah	06h	VOD Level 2 and Pre-emphasis Level 1 for OUT1.
		03h	03h	VOD Level 3 and Pre-emphasis Level 0 for OUT1
00105h	LANE2_SET	00h	00h	VOD Level 0 and Pre-emphasis Level 0 for OUT2.
		08h	04h	VOD Level 0 and Pre-emphasis Level 1 for OUT2.
		10h	08h	VOD Level 0 and Pre-emphasis Level 2 for OUT2.
		18h	0Ch	VOD Level 0 and Pre-emphasis Level 3 for OUT2.
		01h	01h	VOD Level 1 and Pre-emphasis Level 0 for OUT2.
		09h	05h	VOD Level 1 and Pre-emphasis Level 1 for OUT2.
		11h	09h	VOD Level 1 and Pre-emphasis Level 2 for OUT2.
		02h	02h	VOD Level 2 and Pre-emphasis Level 0 for OUT2.
		0Ah	06h	VOD Level 2 and Pre-emphasis Level 1 for OUT2.
		03h	03h	VOD Level 3 and Pre-emphasis Level 0 for OUT2
00106h	LANE3_SET	00h	00h	VOD Level 0 and Pre-emphasis Level 0 for OUT3.
		08h	04h	VOD Level 0 and Pre-emphasis Level 1 for OUT3.
		10h	08h	VOD Level 0 and Pre-emphasis Level 2 for OUT3.
		18h	0Ch	VOD Level 0 and Pre-emphasis Level 3 for OUT3.
		01h	01h	VOD Level 1 and Pre-emphasis Level 0 for OUT3.
		09h	05h	VOD Level 1 and Pre-emphasis Level 1 for OUT3.
		11h	09h	VOD Level 1 and Pre-emphasis Level 2 for OUT3.
		02h	02h	VOD Level 2 and Pre-emphasis Level 0 for OUT3.
		0Ah	06h	VOD Level 2 and Pre-emphasis Level 1 for OUT3.
		03h	03h	VOD Level 3 and Pre-emphasis Level 0 for OUT3
00600h	SET_POWER	01h	00h	Normal Mode
		02h	01h	Power-Down mode.

**TVB1440**

SLASE51A –NOVEMBER 2014–REVISED NOVEMBER 2014

www.ti.com

**9 Application and Implementation****NOTE**

Information in the following applications sections is not part of the TI component specification, and TI does not warrant its accuracy or completeness. TI's customers are responsible for determining suitability of components for their purposes. Customers should validate and test their design implementation to confirm system functionality.

**9.1 Application Information**

TVB1440 is a signal conditioner especially suited for equalizing channel loss due to traces and flexible cable between digital TV chipset and TCON receiver.

**9.1.1 Typical Application**

The device can be helpful improving eye diagram by placing it either end of the flexible cable in digital TV chipset or TCON board or at the both. [Figure 9](#) shows a typical application for TV interface.

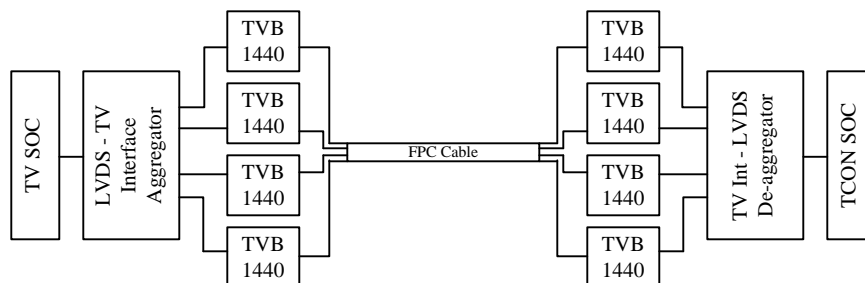

**Figure 9. Typical Application of TVB1440 in 4K2K Digital TV Interface**

**9.1.1.1 Design Requirements**

**Table 5. Design Parameters**

PARAMETER	VALUE
V <sub>DD</sub> Supply	1.1 V
V <sub>CC</sub> Supply	3.3 V
<b>TV Max Resolution Requirement</b>	
Pixel Clock (MHz)	1194
Horizontal Active (pixels)	3840
Vertical Active	2160
Color bit Depth (6bpc, 8bpc, 10bpc)	10 (30 bpc)
Refresh Rate	120 Hz
Panel Configuration (A or B)	B
<b>Channel Requirements</b>	
Input Channel Insertion Loss	Up to 12 dB at 3.75 Gbps
Output Channel Insertion Loss	Up to 12 dB at 3.75 Gbps
<b>TVB1440 Settings</b>	
Number of Lanes (1, 2, or 4)	4
Link Rate (Gbps)	3.75
RX EQ Setting (dB)	6.5 dB
TX VOD Setting (Level 0, 1, 2, or 3)	Level 3 (1000 mVpp)
TX Pre-Emphasis Setting (Level 0, 1, 2, or 3)	Level 0 (0 dB)

### 9.1.1.2 Detailed Design Procedure

#### 9.1.1.2.1 Common 4k2k TV Panel Configuration

A common 4k2k TV is broken into four 1920 x 1080 panels or four 960 x 2160 panels. For this particular implementation, panel configuration B is assumed. It is also assumed that two TVB1440 are used for each panel (one near SOC and one near TCON) for a total of eight TVB1440.

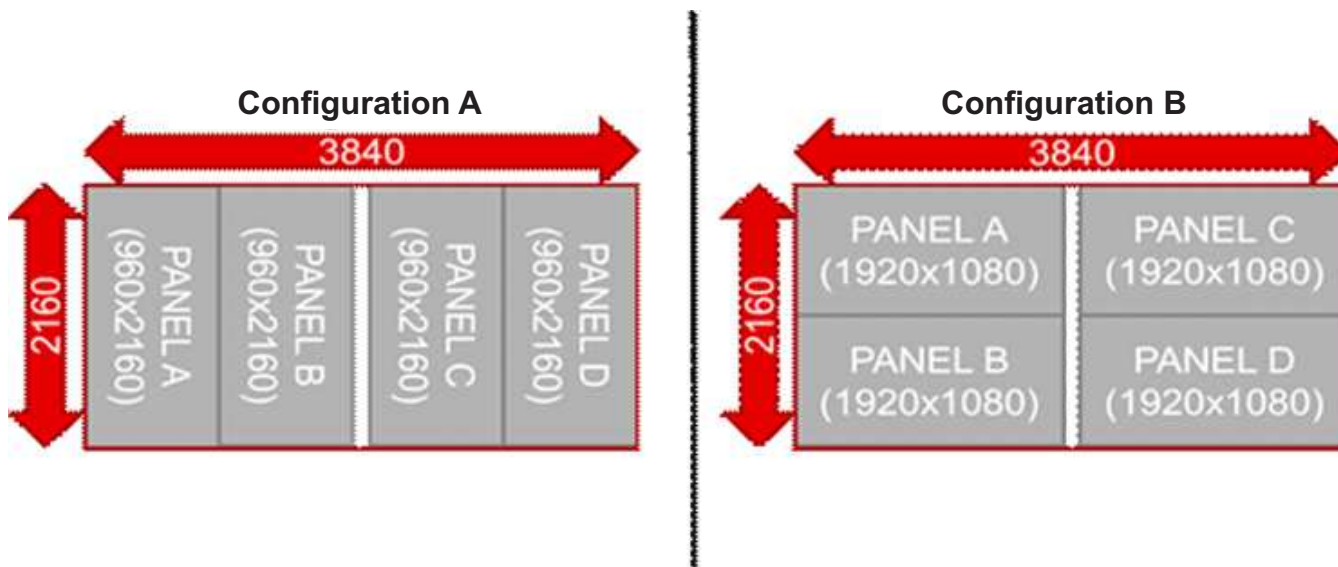

Figure 10. Common Panel Configurations

#### 9.1.1.2.2 1Max Stream Rate

The maximum stream rate can be derived from the maximum TV resolutions pixel clock and color depth. For this example, the maximum pixel clock is 1194 MHz. Because the TV is broken into 4 panels, the actual pixel clock for each panel is 298.5 MHz.

$$\text{Stream Bit Rate} = \text{PixelClock} \times \text{bpp}$$

$$\text{Stream Bit Rate} = 298.5 \times 30$$

$$\text{Stream Bit Rate} = 8.955 \text{ Gbps.}$$

#### 9.1.1.2.3 Encoded Stream Rate

Most high-speed video standards are 8b10b encoded. Because of 8b10b encoding overhead, an additional 20% must be added to the stream bit rate. On top of the 8b10b, there are some additional overhead due to packetization before the 8b10b encode that also must be added to the stream bit rate. For example, a particular video standard may define the actual coded stream rate by the following equation.

$$\text{Encoded\_Stream\_Rate} = \#\_of\_Bytes\_for\_bpp \times 8 \times 1.25 \times \text{PixelClock}$$

$$\text{Encoded\_Stream\_Rate} = \#\_of\_Bytes\_for\_bpp \times 8 \times 1.25 \times \text{PixelClock}$$

$$\text{Encoded\_Stream\_Rate} = 11.94 \text{ Gbps.}$$

**TVB1440**

SLASE51A –NOVEMBER 2014–REVISED NOVEMBER 2014

www.ti.com

**9.1.1.2.4 TVB1440 Configuration**

The TVB1440 must be configured by the SOC using I2C. Because of the limited number of I2C address available on the TVB1440, an I2C switch needs to be incorporated in order to configure each of the TVB1440. Figure 11 shows an example implement using the Texas Instruments TCA9546A 4-channel I2C switch.

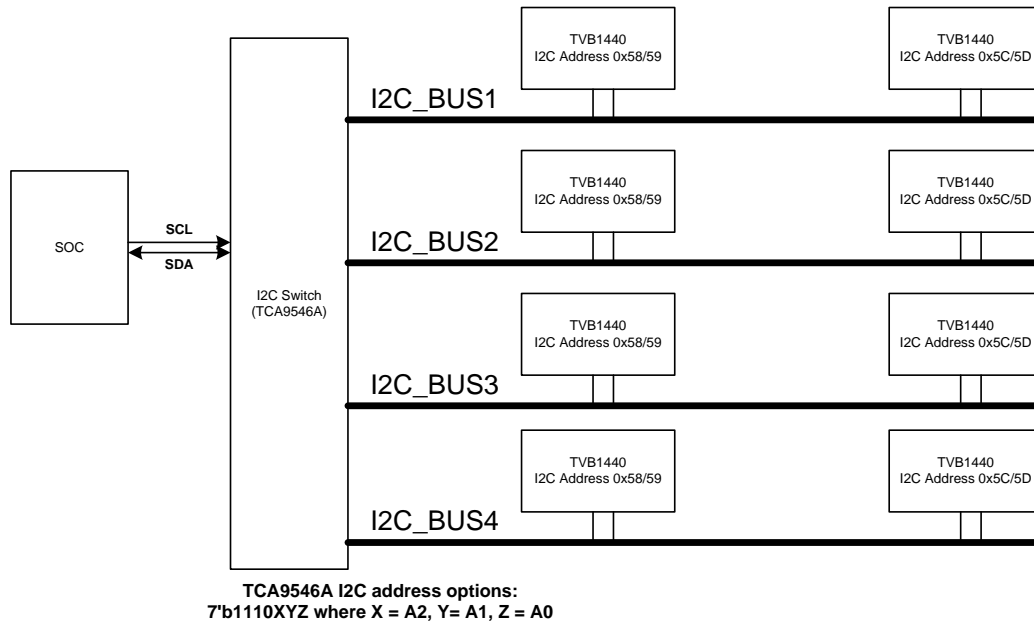
**Figure 11. Example I2C Switch Implementation****9.1.1.2.5 Receiver Equalization Setting**

The TVB1440 has a receiver equalizer that is adjustable from 0dB to 15 dB at 5 Gbps. The common approach to determine the proper equalizer setting is to measure the insertion loss of the channel at the input of the TVB1440 at the Nyquist frequency of the data rate (1.875 GHz for 3.75 Gbps and 2.5 GHz for 5 Gbps). For example, if the input channel is 20 inches of trace with 4 mil width over FR4, the insertion loss at 3.75 Gbps would be -7.3 dB and at 5 Gbps would be -9.1 dB. The register EQ\_LEVEL\_LANEx, where X = 0, 1, 2, or 3 should be programmed to 3'b100 for a 3.75 Gbps data rate and should be programmed to 3'b101. The actual setting may need to be adjusted based on the additional channel parasitics from package, vias, and connectors.

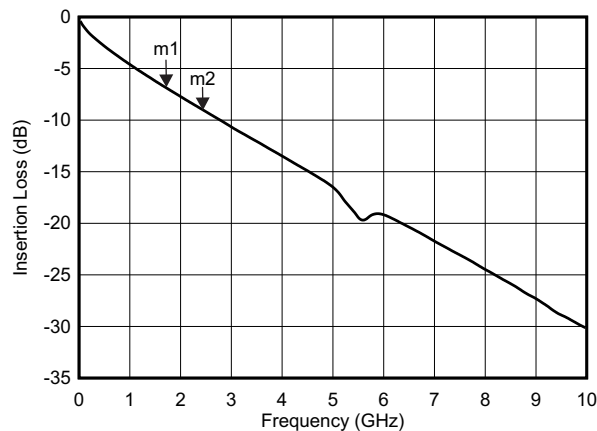

$$m1 \text{ frequency} = 1.876 \text{ GHz} \quad I_L = -7.346$$

$$m2 \text{ frequency} = 2.500 \text{ GHz} \quad I_L = -9.185$$

**Figure 12. Insertion Loss of 20 Inch FR4 Trace With 4-mil Width**

### 9.1.1.2.6 Transmitter Settings

The TVB1440's transmitter controls have four settings for voltage swing and four settings for pre-emphasis. The best transmitter setting to use is a function of the output channel insertion loss and the inputs eye requirement of the device at end of the channel. For the case in which a TVB1440 is at the end of the channel, the output channel's insertion loss should not be greater than the receiver equalization of the TVB1440.

To specify the largest eye opening at the end of the channel, the best voltage swing setting should be either level 2 or level 3. It is also recommended to use either a pre-emphasis level of 0 dB or 3dB. The pre-emphasis setting can be thought of as a way to reduce the amount receiver equalizer required by the device at end channel. For example, a 3.5dB setting could allow for the receive equalization setting for the TVB1440 to be reduced from 12dB to 10dB. If necessary, these settings can be adjusted up or down in order to improve the eye opening at the end of the channel.

### 9.1.1.2.7 RESET

The TVB1440 RSTN input gives control over the device reset and to place the device into shut-down mode. When RSTN is low, all registers are reset to their default values, which means all HS Link ports are disable. When the RSTN pin is released back to high, the device comes out of the shut-down mode. To turn on the HS Link, it is necessary to provision the device registers through the local I<sup>2</sup>C\_CTL interface.

It is critical to transition the RSTN input from a low to a high level after both V<sub>CC</sub> and V<sub>DD</sub> supply voltages have reached the minimum recommended operating voltage. This is achieved by a control signal to the RSTN input, or by an external capacitor connected between RSTN and GND. To insure that the TVB1440 is properly reset, the RSTN pin must be de-asserted for at least 100 μs before being asserted.

The RSTN input includes a 150k resistor from the input to the V<sub>DD</sub> supply. An external capacitor connected between RSTN and GND allows delaying the RSTN signal during power up. When implementing the external capacitor the size of the external capacitor depends on the power up ramp of the V<sub>CC</sub> and V<sub>DD</sub> supplies; a slower ramp-up results in a larger value external capacitor. Approximately 200 nF capacitor is a reasonable first estimate for the size of the external capacitor for most applications.

Both RSTN implementations are shown in [Figure 13](#).

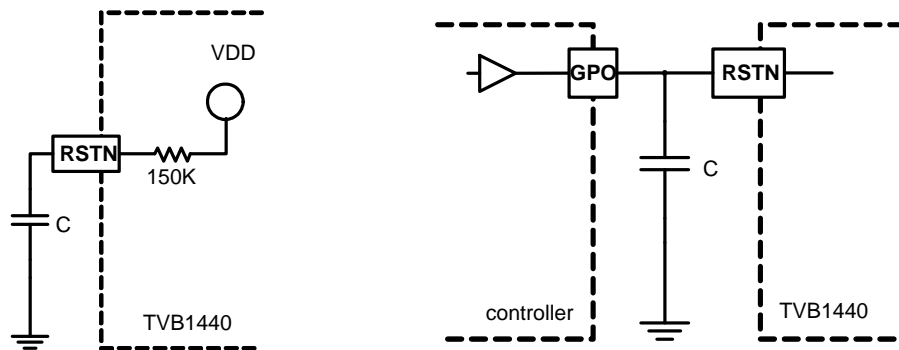

Figure 13. (a) Reset Implementation Using a Capacitor, (b) Microprocessor Drives the Pin

[Figure 14](#) shows a typical schematic implementation either in TV chipset or TCONS receiver board.

**TVB1440**

SLASE51A –NOVEMBER 2014–REVISED NOVEMBER 2014

www.ti.com

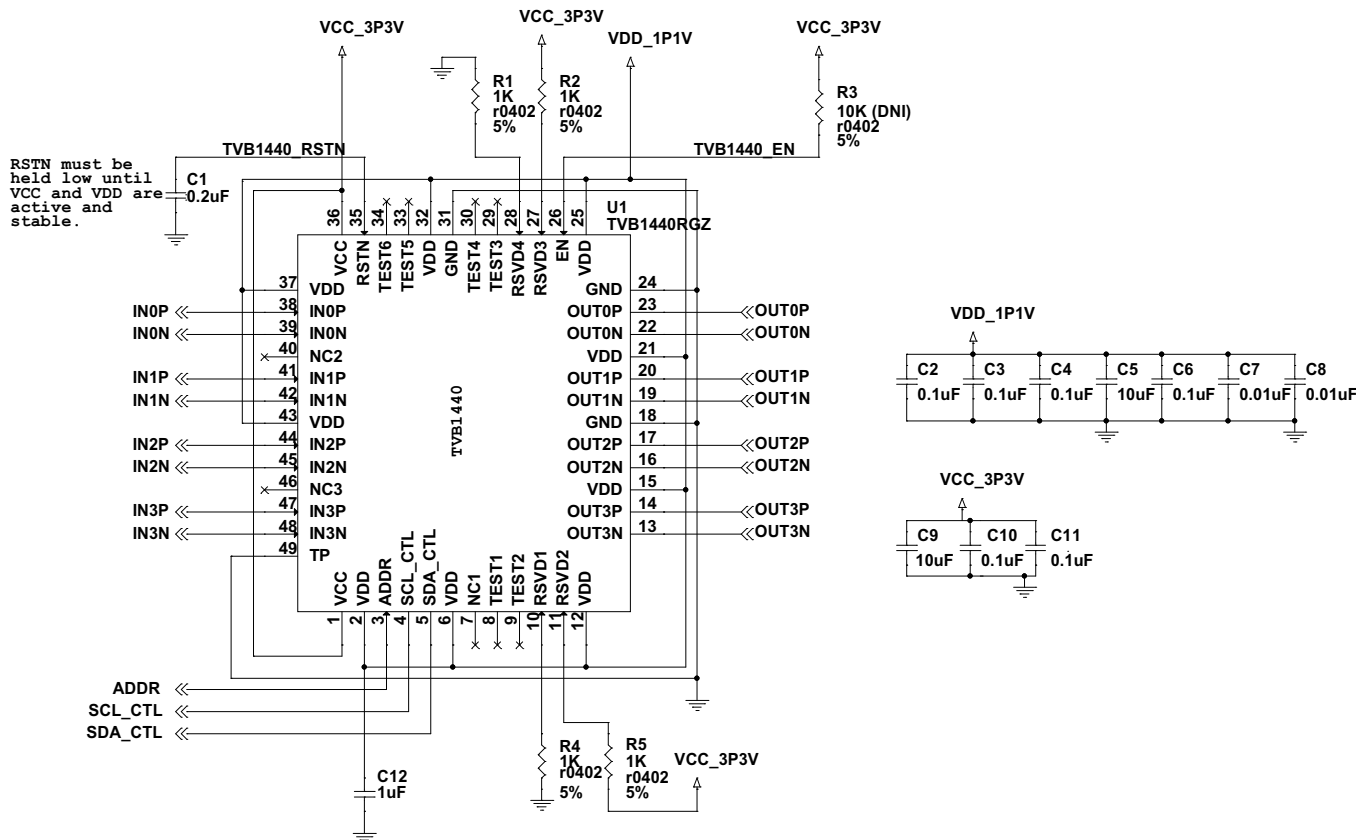

**Figure 14. Schematic Implementation of TVB1440**

## 10 Power Supply Recommendations

The following power-up and power-down sequences describe how the RSTN signal is applied to the TVB1440.

### 10.1 Power-Up Sequence

1. Apply VDD then VCC (recommended both less than 10-ms ramp time). VDD must be asserted first and stable for greater than 10  $\mu$ s before VCC is applied.
2. RSTN must remain asserted until VCC/VDD voltage has reached minimum recommended operation for more than 100  $\mu$ s.
3. De-assert RSTN (Note: This RSTN is a 1.1V interface and is internally connected to VDD through a 150-k $\Omega$  resistor).
4. Device will be available for operation approximately 400 ms after a valid reset.

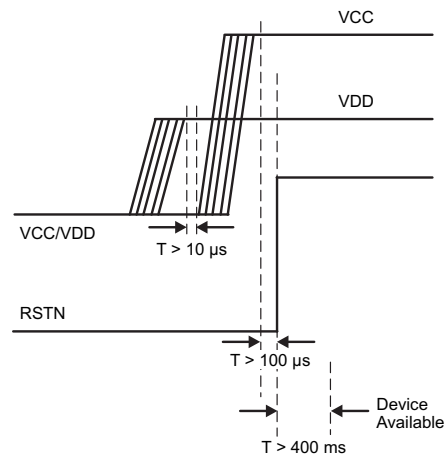

**Figure 15. Power-up Sequence**

### 10.2 Power-Down Sequence

There is no power-down sequence required.

**TVB1440**

SLASE51A –NOVEMBER 2014–REVISED NOVEMBER 2014

www.ti.com

**11 Layout****11.1 Layout Guidelines****11.1.1 Differential Pairs**

This section describes the layout recommendations for all the TVB1440 differential pairs: IN[3:0] and OUT[3:0].

- Must be designed with a differential impedance of  $100\ \Omega \pm 10\%$  or  $50\text{-}\Omega$  single-ended impedance.
- In order to minimize cross talk, it is recommended to keep high speed signals away from each other. Each pair should be separated by at least 5 times the signal trace width.
- Route all differential pairs on the same layer adjacent to a solid ground plane.
- Do not route differential pairs over any plane split.
- Adding test points causes impedance discontinuity and; therefore, negative impacts signal performance. If test points are used, they should be placed in series and symmetrically. They must not be placed in a manner that causes stub on the differential pair.
- Avoid 90 degree turns in trace. The use of bends in differential traces should be kept to a minimum. When bends are used, the number of left and right bends should be as equal as possible and the angle of the bend should be  $\geq 135$  degrees. This minimizes any length mismatch causes by the bends; and therefore, minimizes the impact bends have on EMI.
- Minimize the trace lengths of the differential pair traces. Longer trace lengths require very careful routing to assure proper signal integrity.
- Keep intra-pair skew to a minimum in order to minimize EMI. There should be less than 5 mils difference between a differential pair signal and its complement.
- Minimize the use of vias in the differential pair paths as much as possible. If this is not practical, make sure that the same via type and placement are used for both signals in a pair. It is recommended to keep the vias count to 2 or less.

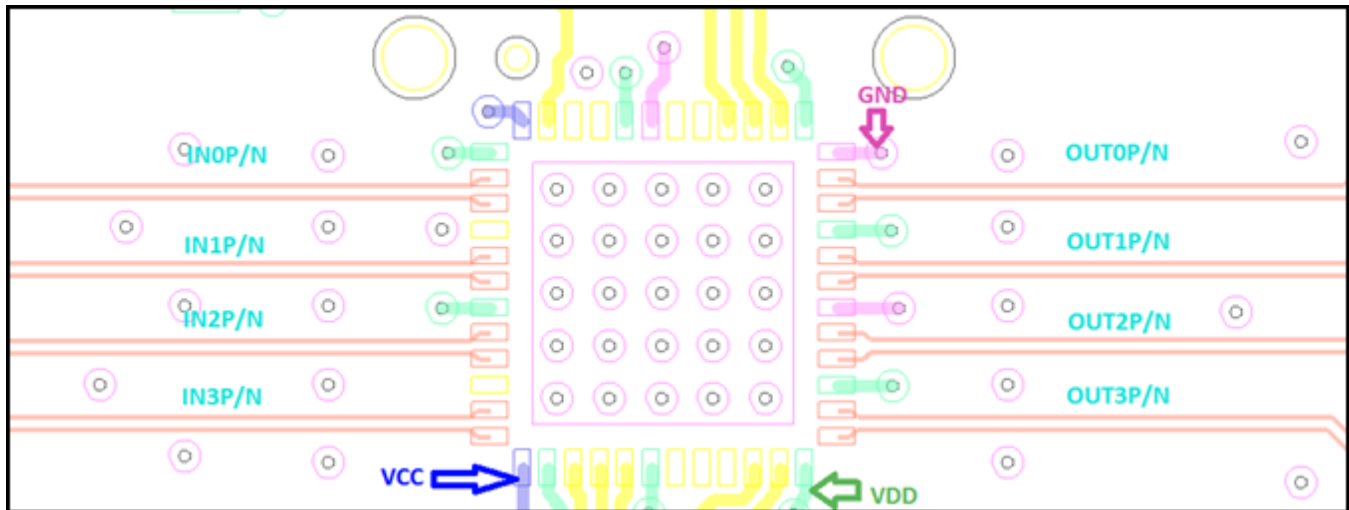
**11.1.2 Layout Example****Figure 16. TBV1440 Layout**

## Layout Guidelines (continued)

### 11.1.3 Placement

- A 100-nF should be placed as close as possible on each  $V_{DD}$  and  $V_{CC}$  power pin.
- The 100-nF capacitors on the IN[3:0] and OUT[3:0] nets should be placed close to the connector.
- The ESD and EMI protection devices (if used) should also be placed as possible to the connector.

### 11.1.4 Package Specific

- The TVB1440 package as a 0.5 mm pin pitch
- The TVB1440 package has a 4.1 mm x 4.1 mm thermal pad. This thermal pad must be connected to ground through a system of vias.
- All vias under device, except for those connected to thermal pad, should be solder masked to avoid any potential issues with thermal pad layouts.

### 11.1.5 Ground

It is recommended that only one board plane be used in the design. This provides the best image plane for signal traces running above the plane. The thermal pad of the TVB1440 should be connected to this plane through a system of vias.

## 12 Device and Documentation Support

### 12.1 Trademarks

All trademarks are the property of their respective owners.

### 12.2 Electrostatic Discharge Caution



These devices have limited built-in ESD protection. The leads should be shorted together or the device placed in conductive foam during storage or handling to prevent electrostatic damage to the MOS gates.

### 12.3 Export Control Notice

Recipient agrees to not knowingly export or re-export, directly or indirectly, any product or technical data (as defined by the U.S., EU, and other Export Administration Regulations) including software, or any controlled product restricted by other applicable national regulations, received from disclosing party under nondisclosure obligations (if any), or any direct product of such technology, to any destination to which such export or re-export is restricted or prohibited by U.S. or other applicable laws, without obtaining prior authorization from U.S. Department of Commerce and other competent Government authorities to the extent required by those laws.

### 12.4 Glossary

[SLYZ022](#) — *TI Glossary*.

This glossary lists and explains terms, acronyms, and definitions.

## 13 Mechanical, Packaging, and Orderable Information

The following pages include mechanical, packaging, and orderable information. This information is the most current data available for the designated devices. This data is subject to change without notice and revision of this document. For browser-based versions of this data sheet, refer to the left-hand navigation.

## PACKAGING INFORMATION

Orderable Device	Status (1)	Package Type	Package Drawing	Pins	Package Qty	Eco Plan (2)	Lead finish/ Ball material (6)	MSL Peak Temp (3)	Op Temp (°C)	Device Marking (4/5)	Samples
TVB1440RGZR	ACTIVE	VQFN	RGZ	48	2500	RoHS & Green	NIPDAU	Level-3-260C-168 HR	0 to 85	TVB1440	<b>Samples</b>

(1) The marketing status values are defined as follows:

**ACTIVE:** Product device recommended for new designs.

**LIFEBUY:** TI has announced that the device will be discontinued, and a lifetime-buy period is in effect.

**NRND:** Not recommended for new designs. Device is in production to support existing customers, but TI does not recommend using this part in a new design.

**PREVIEW:** Device has been announced but is not in production. Samples may or may not be available.

**OBSOLETE:** TI has discontinued the production of the device.

(2) **RoHS:** TI defines "RoHS" to mean semiconductor products that are compliant with the current EU RoHS requirements for all 10 RoHS substances, including the requirement that RoHS substance do not exceed 0.1% by weight in homogeneous materials. Where designed to be soldered at high temperatures, "RoHS" products are suitable for use in specified lead-free processes. TI may reference these types of products as "Pb-Free".

**RoHS Exempt:** TI defines "RoHS Exempt" to mean products that contain lead but are compliant with EU RoHS pursuant to a specific EU RoHS exemption.

**Green:** TI defines "Green" to mean the content of Chlorine (Cl) and Bromine (Br) based flame retardants meet JS709B low halogen requirements of <=1000ppm threshold. Antimony trioxide based flame retardants must also meet the <=1000ppm threshold requirement.

(3) MSL, Peak Temp. - The Moisture Sensitivity Level rating according to the JEDEC industry standard classifications, and peak solder temperature.

(4) There may be additional marking, which relates to the logo, the lot trace code information, or the environmental category on the device.

(5) Multiple Device Markings will be inside parentheses. Only one Device Marking contained in parentheses and separated by a "-" will appear on a device. If a line is indented then it is a continuation of the previous line and the two combined represent the entire Device Marking for that device.

(6) Lead finish/Ball material - Orderable Devices may have multiple material finish options. Finish options are separated by a vertical ruled line. Lead finish/Ball material values may wrap to two lines if the finish value exceeds the maximum column width.

**Important Information and Disclaimer:** The information provided on this page represents TI's knowledge and belief as of the date that it is provided. TI bases its knowledge and belief on information provided by third parties, and makes no representation or warranty as to the accuracy of such information. Efforts are underway to better integrate information from third parties. TI has taken and continues to take reasonable steps to provide representative and accurate information but may not have conducted destructive testing or chemical analysis on incoming materials and chemicals. TI and TI suppliers consider certain information to be proprietary, and thus CAS numbers and other limited information may not be available for release.

In no event shall TI's liability arising out of such information exceed the total purchase price of the TI part(s) at issue in this document sold by TI to Customer on an annual basis.

## TAPE AND REEL INFORMATION



### QUADRANT ASSIGNMENTS FOR PIN 1 ORIENTATION IN TAPE



\*All dimensions are nominal

Device	Package Type	Package Drawing	Pins	SPQ	Reel Diameter (mm)	Reel Width W1 (mm)	A0 (mm)	B0 (mm)	K0 (mm)	P1 (mm)	W (mm)	Pin1 Quadrant
TVB1440RGZR	VQFN	RGZ	48	2500	330.0	16.4	7.3	7.3	1.1	12.0	16.0	Q2

TAPE AND REEL BOX DIMENSIONS



\*All dimensions are nominal

Device	Package Type	Package Drawing	Pins	SPQ	Length (mm)	Width (mm)	Height (mm)
TVB1440RGZR	VQFN	RGZ	48	2500	367.0	367.0	38.0

## GENERIC PACKAGE VIEW

**RGZ 48**

**VQFN - 1 mm max height**

7 x 7, 0.5 mm pitch

PLASTIC QUADFLAT PACK- NO LEAD

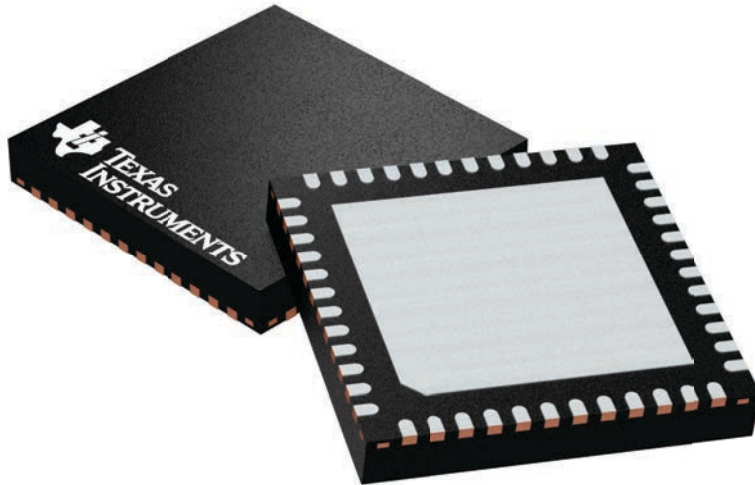

Images above are just a representation of the package family, actual package may vary.  
Refer to the product data sheet for package details.

4224671/A

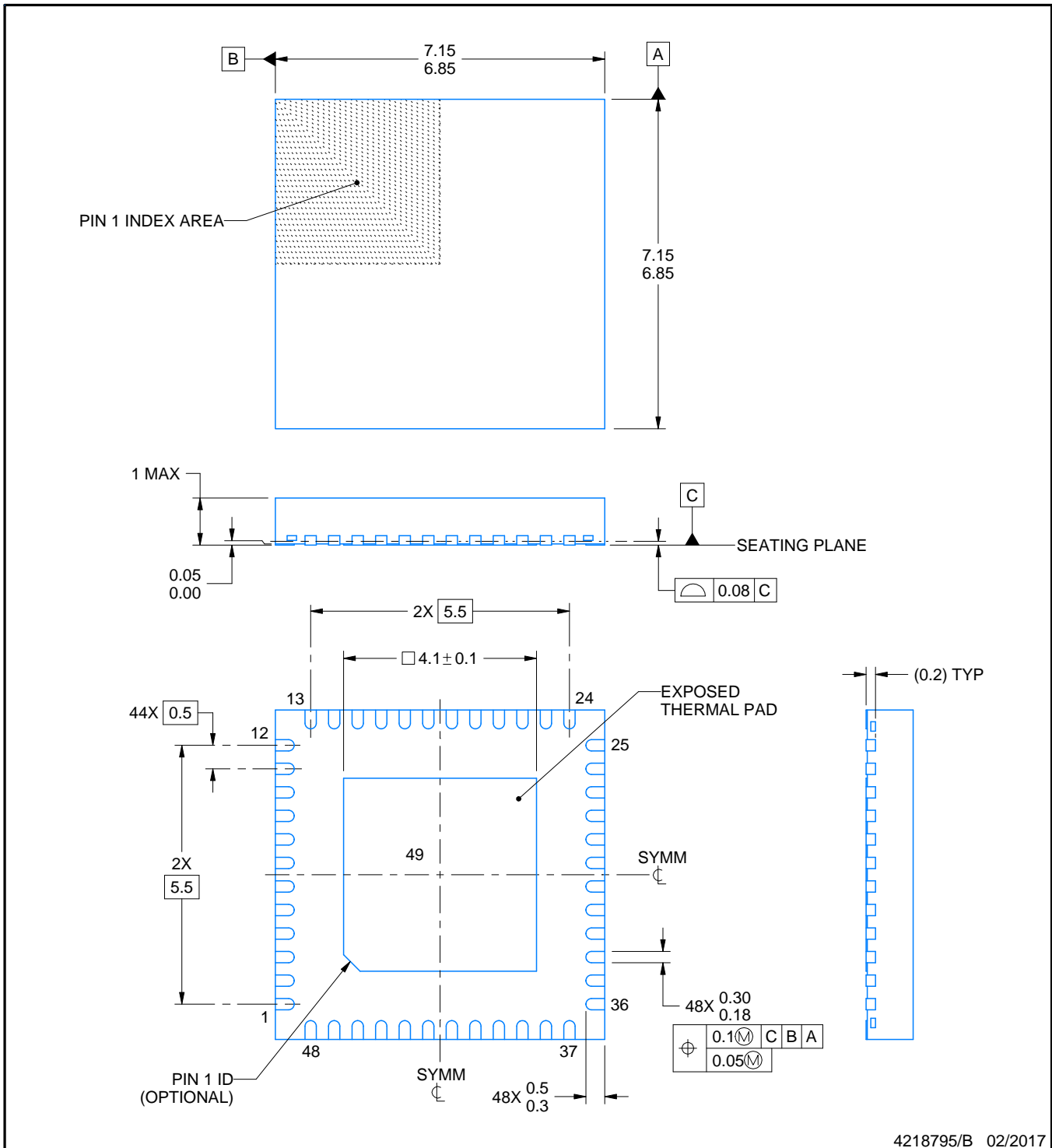
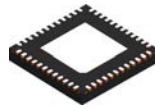

4218795/B 02/2017

NOTES:

1. All linear dimensions are in millimeters. Any dimensions in parenthesis are for reference only. Dimensioning and tolerancing per ASME Y14.5M.
2. This drawing is subject to change without notice.
3. The package thermal pad must be soldered to the printed circuit board for thermal and mechanical performance.

# EXAMPLE BOARD LAYOUT

**RGZ0048B**

**VQFN - 1 mm max height**

PLASTIC QUAD FLATPACK - NO LEAD

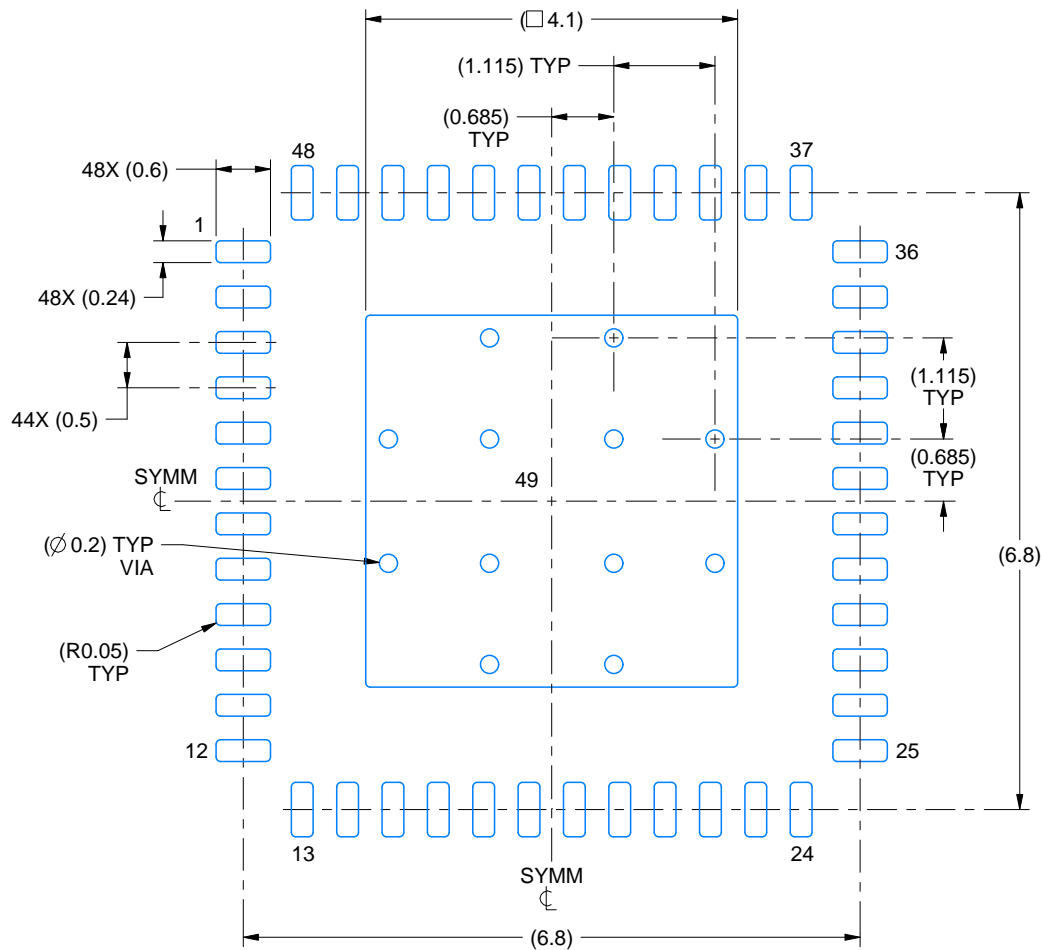

**LAND PATTERN EXAMPLE**  
EXPOSED METAL SHOWN  
SCALE:12X

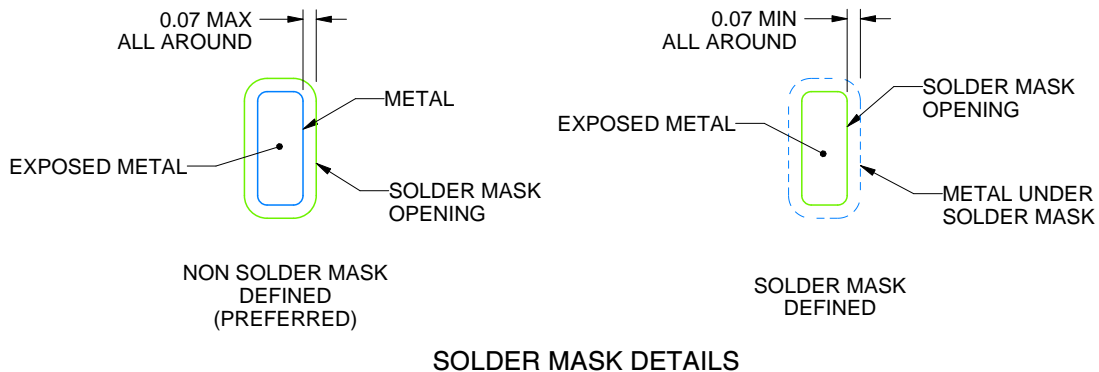

4218795/B 02/2017

NOTES: (continued)

4. This package is designed to be soldered to a thermal pad on the board. For more information, see Texas Instruments literature number SLUA271 ([www.ti.com/lit/sluea271](http://www.ti.com/lit/sluea271)).
5. Vias are optional depending on application, refer to device data sheet. If any vias are implemented, refer to their locations shown on this view. It is recommended that vias under paste be filled, plugged or tented.

# EXAMPLE STENCIL DESIGN

RGZ0048B

VQFN - 1 mm max height

PLASTIC QUAD FLATPACK - NO LEAD

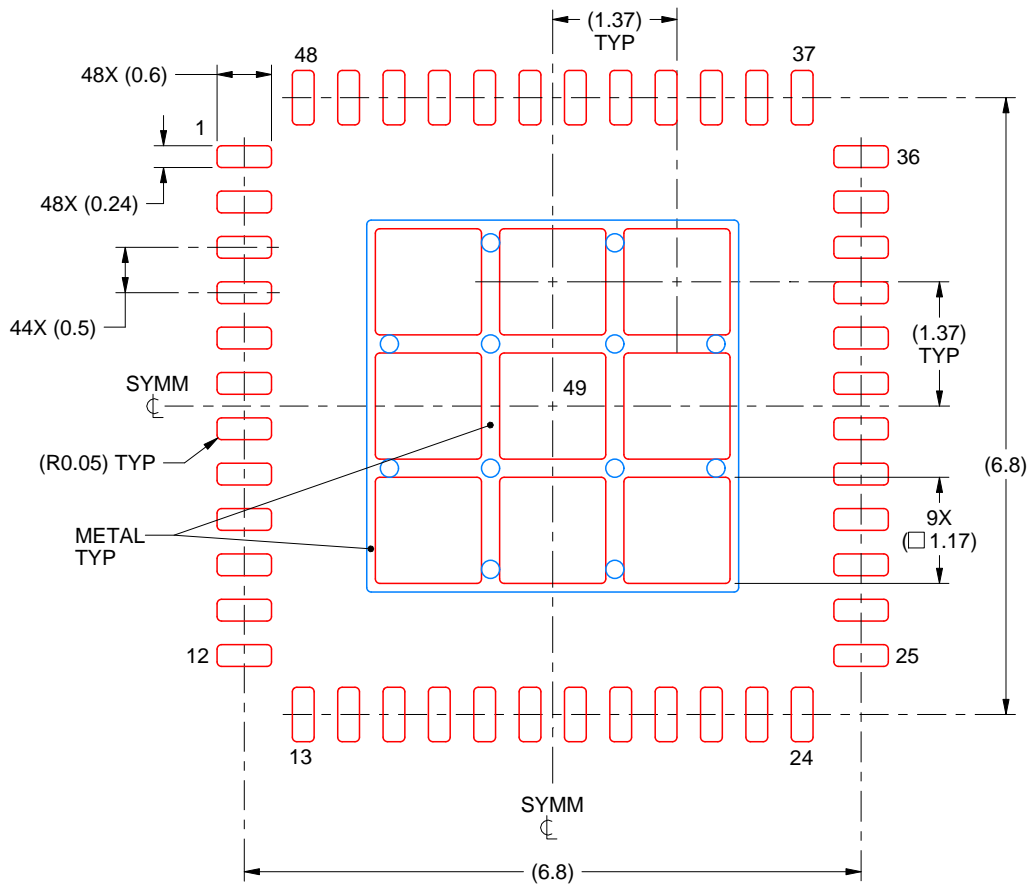

## SOLDER PASTE EXAMPLE BASED ON 0.125 mm THICK STENCIL

EXPOSED PAD 49  
73% PRINTED SOLDER COVERAGE BY AREA UNDER PACKAGE  
SCALE:12X

4218795/B 02/2017

NOTES: (continued)

6. Laser cutting apertures with trapezoidal walls and rounded corners may offer better paste release. IPC-7525 may have alternate design recommendations.

## IMPORTANT NOTICE AND DISCLAIMER

TI PROVIDES TECHNICAL AND RELIABILITY DATA (INCLUDING DATASHEETS), DESIGN RESOURCES (INCLUDING REFERENCE DESIGNS), APPLICATION OR OTHER DESIGN ADVICE, WEB TOOLS, SAFETY INFORMATION, AND OTHER RESOURCES "AS IS" AND WITH ALL FAULTS, AND DISCLAIMS ALL WARRANTIES, EXPRESS AND IMPLIED, INCLUDING WITHOUT LIMITATION ANY IMPLIED WARRANTIES OF MERCHANTABILITY, FITNESS FOR A PARTICULAR PURPOSE OR NON-INFRINGEMENT OF THIRD PARTY INTELLECTUAL PROPERTY RIGHTS.

These resources are intended for skilled developers designing with TI products. You are solely responsible for (1) selecting the appropriate TI products for your application, (2) designing, validating and testing your application, and (3) ensuring your application meets applicable standards, and any other safety, security, or other requirements. These resources are subject to change without notice. TI grants you permission to use these resources only for development of an application that uses the TI products described in the resource. Other reproduction and display of these resources is prohibited. No license is granted to any other TI intellectual property right or to any third party intellectual property right. TI disclaims responsibility for, and you will fully indemnify TI and its representatives against, any claims, damages, costs, losses, and liabilities arising out of your use of these resources.

TI's products are provided subject to TI's Terms of Sale ([www.ti.com/legal/termsofsale.html](http://www.ti.com/legal/termsofsale.html)) or other applicable terms available either on [ti.com](http://ti.com) or provided in conjunction with such TI products. TI's provision of these resources does not expand or otherwise alter TI's applicable warranties or warranty disclaimers for TI products.

Mailing Address: Texas Instruments, Post Office Box 655303, Dallas, Texas 75265  
Copyright © 2020, Texas Instruments Incorporated

## Looking for pricing, stock, or lifecycle information?

Click below to explore more details on WIN SOURCE:

 [View AC0805JR-0733KL on WIN SOURCE](#)

 [Yageo Information](#)

## Optimize Your Supply Chain with WIN SOURCE Solutions

-  Global Sourcing Solution
-  Obsolete Management
-  Cost Control Management
-  Shortage Management
-  Alternative Solution
-  Excess Inventory Management