



**THE DATASHEET OF  
ICS-40619**



## High Dynamic Range Microphone with Differential Output and Low Power

### GENERAL DESCRIPTION

The ICS-40619 is an analog MEMS microphone with very high SNR and a low-power AlwaysOn mode. The ICS-40619 includes a MEMS microphone element, an impedance converter, and a differential output amplifier.

This microphone features a low-power mode, which is activated when the supply voltage is <math><2.0\text{ V}</math>. In this mode, the ICS-40619 operates with  $55\ \mu\text{A}</math>.$

Other high-performance specifications include 132 dB SPL acoustic overload point in high performance mode, tight  $\pm 1\text{ dB}</math> sensitivity tolerance and enhanced immunity to both radiated and conducted RF interference.$

The ICS-40619's electro-acoustic performance matches the bottom port ICS-40618, making this pair of microphones suitable to use together in applications requiring both top and bottom port devices.

The ICS-40619 is available in a small  $3.50\text{ mm} \times 2.65\text{ mm} \times 0.98\text{ mm}</math> top port surface-mount package.$

### APPLICATIONS

- Smartphones
- "AlwaysOn" listening
- Wearable devices
- Still and video cameras
- IoT devices

### FEATURES

SPEC	HIGH PERFORMANCE MODE	LOW-POWER MODE
SNR	67 dBA	67 dBA
Current	165 $\mu\text{A}$	55 $\mu\text{A}$
AOP	132 dB SPL	129 dB SPL

- Differential non-inverting analog output
- $-38\text{ dBV}</math> sensitivity (differential)$
- $\pm 1\text{ dB}</math> sensitivity tolerance$
- Extended frequency response from 50 Hz to 20 kHz
- Enhanced RF immunity
- $-52\text{ dB PSRR}</math>$
- $3.50 \times 2.65 \times 0.98\text{ mm}</math> top port surface-mount package$
- Compatible with Sn/Pb and Pb-free solder processes
- RoHS/WEEE compliant

### FUNCTIONAL BLOCK DIAGRAM

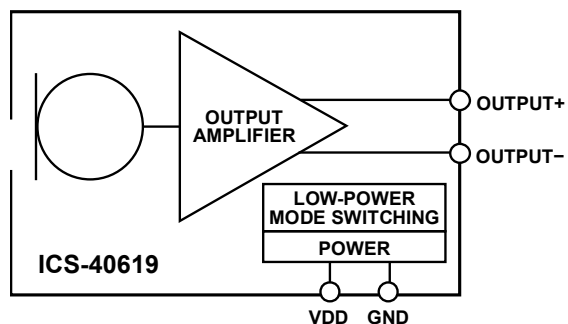

### ORDERING INFORMATION

PART	TEMP RANGE	PACKAGING
ICS-40619	$-40^{\circ}\text{C}$ to $+85^{\circ}\text{C}$	13" Tape and Reel
EV_IC3-40619-FX	—	

**TABLE OF CONTENTS**

General Description ..... 1

Applications ..... 1

Features ..... 1

Functional Block Diagram ..... 1

Ordering Information..... 1

Table of Contents ..... 2

Specifications ..... 3

    Table 1. Electrical Characteristics ..... 3

Absolute Maximum Ratings ..... 5

    Table 2. Absolute Maximum Ratings ..... 5

    ESD Caution ..... 5

    Soldering Profile..... 6

    Table 3. Recommended Soldering Profile\* ..... 6

Pin Configurations And Function Descriptions ..... 7

    Table 4. Pin Function Descriptions..... 7

Typical Performance Characteristics..... 8

Theory Of Operation ..... 9

    Low-Power Mode..... 9

    Balanced Output ..... 9

Applications Information ..... 10

    Codec Connection..... 10

Supporting Documents ..... 11

    Evaluation Board User Guide..... 11

    Application Notes ..... 11

PCB Design And Land Pattern Layout ..... 12

    PCB Material And Thickness ..... 12

Handling Instructions..... 13

    Pick And Place Equipment ..... 13

    Reflow Solder..... 13

    Board Wash ..... 13

Outline Dimensions..... 14

    Ordering Guide ..... 15

    Revision History ..... 16

Compliance Declaration Disclaimer ..... 17

**SPECIFICATIONS**

**TABLE 1. ELECTRICAL CHARACTERISTICS**

T<sub>A</sub> = 25°C, V<sub>DD</sub> = 1.52 to 3.63 V, unless otherwise noted. Typical specifications are not guaranteed.

PARAMETER	CONDITIONS	MIN	TYP	MAX	UNITS	NOTES
<b>PERFORMANCE</b>						
Directionality		Omni				
Output Polarity		Non-Inverted				
Sensitivity	1 kHz, 94 dB SPL, differential	-39	-38	-37	dBV	
<b>HIGH PERFORMANCE MODE</b>						
Signal-to-Noise Ratio (SNR)	20 Hz to 20 kHz, A-weighted		67		dB	
Equivalent Input Noise (EIN)	20 Hz to 20 kHz, A-weighted		27		dB	SPL
Dynamic Range	Derived from EIN and acoustic overload point		105		dB	
Total Harmonic Distortion (THD)	105 dB SPL		0.2		%	
Power Supply Rejection Ratio (PSRR)	1 kHz, 100 mV p-p sine wave superimposed on V <sub>DD</sub> = 2.75 V		-52		dB	
Power Supply Rejection (PSR)	217 Hz, 100 mVp-p square wave superimposed on V <sub>DD</sub> = 2.75 V		-84		dBV	
Acoustic Overload Point	10% THD, V <sub>DD</sub> = 2.75 V		132		dB	SPL
<b>LOW-POWER MODE</b>						
Signal-to-Noise Ratio (SNR)	8 kHz bandwidth, A-weighted		67		dB	
Equivalent Input Noise (EIN)	8 kHz bandwidth, A-weighted		27		dB	SPL
Dynamic Range	Derived from EIN and acoustic overload point		102		dB	
Total Harmonic Distortion (THD)	105 dB SPL		0.2		%	
Power Supply Rejection Ratio (PSRR)	1 kHz, 100 mV p-p sine wave superimposed on V <sub>DD</sub> = 1.8 V		-52		dB	
Power Supply Rejection (PSR)	217 Hz, 100 mVp-p square wave superimposed on V <sub>DD</sub> = 1.8 V		-84		dBV	
Acoustic Overload Point	10% THD, V <sub>DD</sub> = 1.8 V		129		dB	SPL
<b>POWER SUPPLY</b>						
Supply Voltage (V <sub>DD</sub> )	Low-power mode	1.52		2.0	V	
	High performance mode	2.2		3.63	V	
Supply Current (I <sub>s</sub> )	V <sub>DD</sub> = 1.8 V		55	65	μA	
	V <sub>DD</sub> = 2.75 V		165	190	μA	

PARAMETER	CONDITIONS	MIN	TYP	MAX	UNITS	NOTES
<b>OUTPUT CHARACTERISTICS</b>						
Differential Output Impedance	High-performance mode		355		$\Omega$	
	Low-power mode		5.5		k $\Omega$	
Output Common Mode Voltage	OUTPUT+ and OUTPUT-, high-performance mode		1.0		V	
	OUTPUT+ and OUTPUT-, low-power mode		0.8		V	
Output Differential Offset	Between OUTPUT+ and OUTPUT-, high-performance mode		10		mV	
	Between OUTPUT+ and OUTPUT-, low-power mode		10		mV	
Startup Time	Output to within $\pm 0.5$ dB of stable sensitivity		15	20	ms	
Mode Switching Time	High performance mode to low-power mode			1	ms	
	Low-power mode to high performance mode			1	ms	
Output Voltage at AOP	132 dB SPL input		1.0		V rms	
Noise Floor	20 Hz to 20 kHz, A-weighted, rms, high performance mode		-105		dBV	

## ABSOLUTE MAXIMUM RATINGS

Stress above those listed as Absolute Maximum Ratings may cause permanent damage to the device. These are stress ratings only and functional operation of the device at these conditions is not implied. Exposure to the absolute maximum ratings conditions for extended periods may affect device reliability.

**TABLE 2. ABSOLUTE MAXIMUM RATINGS**

PARAMETER	RATING
Supply Voltage ( $V_{DD}$ )	-0.3 V to +3.63 V
Sound Pressure Level	160 dB
Mechanical Shock	10,000 <i>g</i>
Vibration	Per MIL-STD-883 Method 2007, Test Condition B
Temperature Range	
Biased	-40°C to +85°C
Storage	-55°C to +150°C

## ESD CAUTION



ESD (electrostatic discharge) sensitive device. Charged devices and circuit boards can discharge without detection. Although this product features patented or proprietary protection circuitry, damage may occur on devices subjected to high energy ESD. Therefore proper ESD precautions should be taken to avoid performance degradation or loss of functionality.

SOLDERING PROFILE

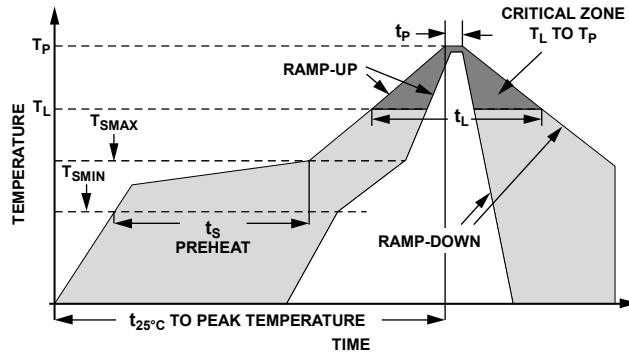

Figure 1. Recommended Soldering Profile Limits

TABLE 3. RECOMMENDED SOLDERING PROFILE\*

PROFILE FEATURE		Sn63/Pb37	Pb-Free
Average Ramp Rate ( $T_L$ to $T_P$ )		1.25°C/sec max	1.25°C/sec max
Preheat	Minimum Temperature ( $T_{SMIN}$ )	100°C	100°C
	Minimum Temperature ( $T_{SMIN}$ )	150°C	200°C
	Time ( $T_{SMIN}$ to $T_{SMAX}$ ), $t_s$	60 sec to 75 sec	60 sec to 75 sec
Ramp-Up Rate ( $T_{SMAX}$ to $T_L$ )		1.25°C/sec	1.25°C/sec
Time Maintained Above Liquidous ( $t_L$ )		45 sec to 75 sec	~50 sec
Liquidous Temperature ( $T_L$ )		183°C	217°C
Peak Temperature ( $T_P$ )		215°C +3°C/-3°C	260°C +0°C/-5°C
Time Within +5°C of Actual Peak Temperature ( $t_p$ )		20 sec to 30 sec	20 sec to 30 sec
Ramp-Down Rate		3°C/sec max	3°C/sec max
Time +25°C ( $t_{25^\circ\text{C}}$ ) to Peak Temperature		5 min max	5 min max

\*The reflow profile in Table 3 is recommended for board manufacturing with InvenSense MEMS microphones. All microphones are also compatible with the J-STD-020 profile

**PIN CONFIGURATIONS AND FUNCTION DESCRIPTIONS**

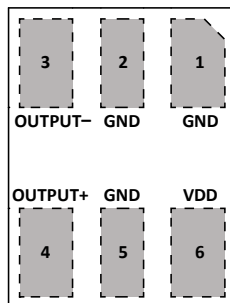

**Figure 2. Pin Configuration (Top View, Terminal Side Down)**

**TABLE 4. PIN FUNCTION DESCRIPTIONS**

PIN	NAME	FUNCTION
1	GND	Ground
2	GND	Ground
3	OUTPUT-	Analog Output Signal-
4	OUTPUT+	Analog Output Signal+
5	GND	Ground
6	VDD	Power Supply

TYPICAL PERFORMANCE CHARACTERISTICS

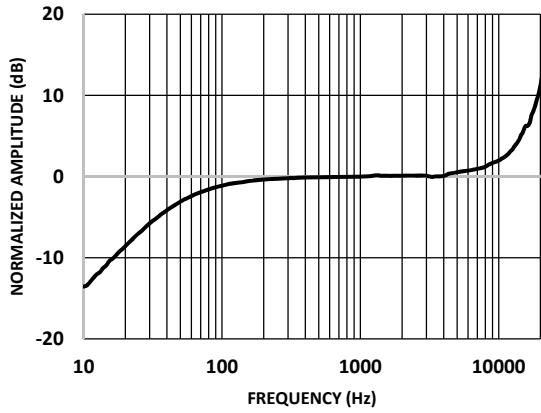

Figure 3. Typical Frequency Response (Measured)

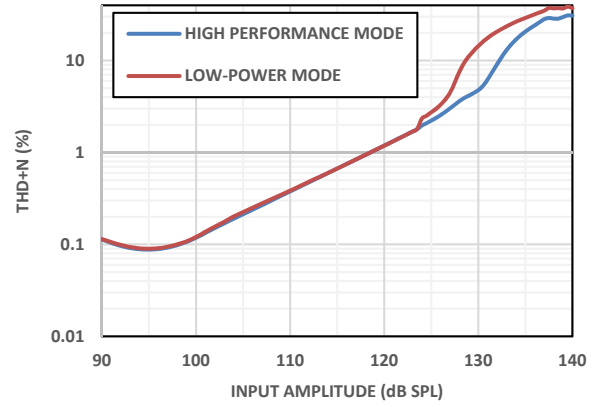

Figure 4. THD + N vs. Input Level

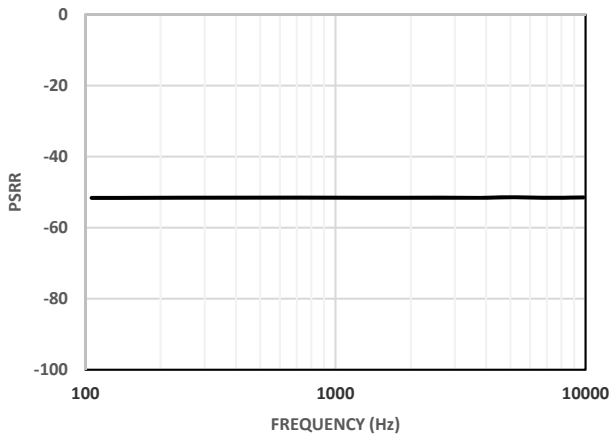

Figure 5. Power-Supply Rejection Ratio (PSRR) vs. Frequency

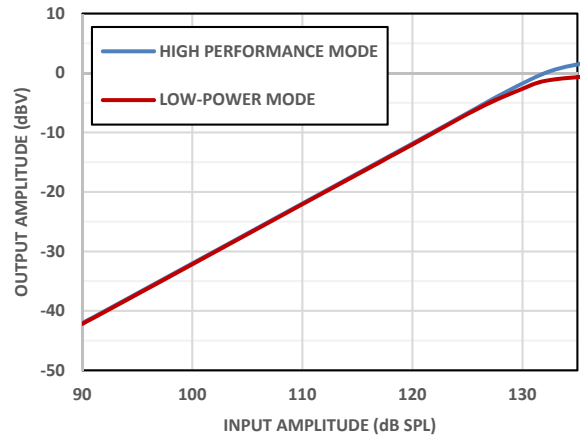

Figure 6. Linearity

## **THEORY OF OPERATION**

### **LOW-POWER MODE**

The ICS-40619 will enter a low-power mode when the supply voltage  $V_{DD}$  falls below 2.0 V. In this mode, the microphone will operate with 55  $\mu$ A supply current. While the microphone is switched between the two modes, the output signals should be muted for a short time.

### **BALANCED OUTPUT**

The ICS-40619 has a balanced differential output with 355  $\Omega$  output impedance in high performance mode and 5.5 k $\Omega$  in low-power mode. This configuration is compatible with a fully-differential codec input and provides the benefits of a balanced signal between the microphone and codec. A balanced analog audio signal provides rejection of common-mode noise that is present on both the positive and negative signals.

## APPLICATIONS INFORMATION

### CODEC CONNECTION

The ICS-40619 output can be connected to a dedicated codec microphone input (see Figure 7) or to a high input impedance gain stage. A 0.1  $\mu\text{F}$  ceramic capacitor placed close to the ICS-40619 supply pin is used for testing and is recommended to adequately decouple the microphone from noise on the power supply. A dc blocking capacitor is required at the output of the microphone. This capacitor creates a high-pass filter with a corner frequency at

$$f_c = 1/(2\pi \times C \times R)$$

where  $R$  is the input impedance of the codec.

A minimum value of 2.2  $\mu\text{F}$  is recommended in Figure 7 for codecs which may have a very low input impedance at some PGA gain settings.

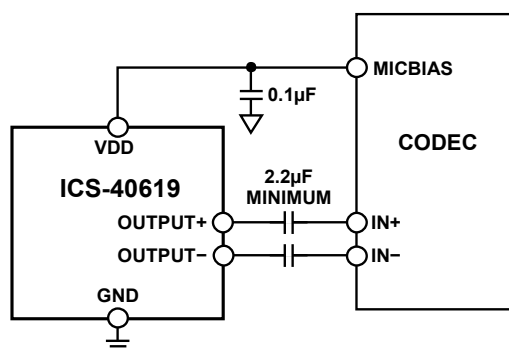

Figure 7. ICS-40619 Connected to a Differential-Input Codec

## **SUPPORTING DOCUMENTS**

For additional information, see the following documents.

### **EVALUATION BOARD USER GUIDE**

AN-000012, *Differential Analog Output MEMS Microphone Flex Evaluation Board*

### **APPLICATION NOTES**

AN-100, *MEMS Microphone Handling and Assembly Guide*

AN-1003, *Recommendations for Mounting and Connecting the InvenSense Bottom-Ported MEMS Microphones*

AN-1112, *Microphone Specifications Explained*

AN-1124, *Recommendations for Sealing InvenSense Bottom-Port MEMS Microphones from Dust and Liquid Ingress*

AN-1140, *Microphone Array Beamforming*

AN-1165, *Op Amps for Microphone Preamp Circuits*

### PCB DESIGN AND LAND PATTERN LAYOUT

Lay out the PCB land pattern for the ICS-40619 at a 1:1 ratio to the solder pads on the microphone package (see Figure 8.) Take care to avoid applying solder paste to the sound hole in the PCB. Figure 9 shows a suggested solder paste stencil pattern layout.

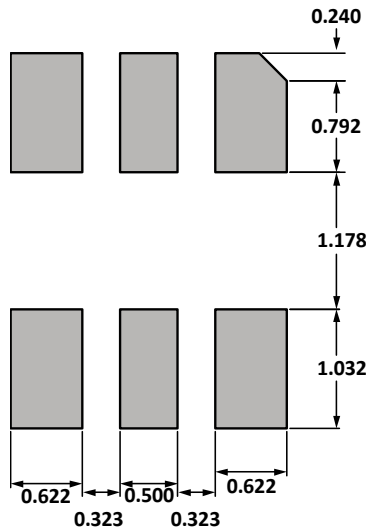

Figure 8. Recommended PCB Land Pattern Layout

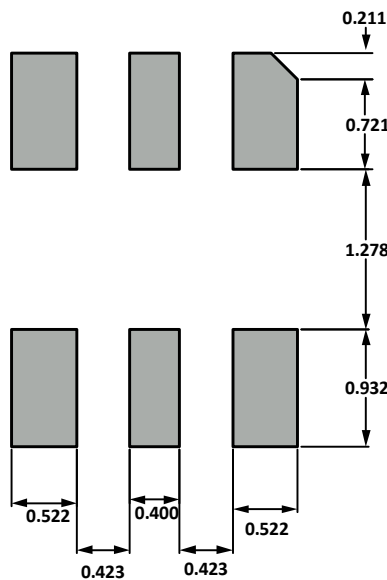

Figure 9. Recommended Solder Paste Stencil Pattern Layout

### PCB MATERIAL AND THICKNESS

The ICS-40619 can be mounted on either a rigid or flexible PCB. A microphone’s lid can be attached directly to the device housing with an adhesive layer. This mounting method offers a reliable seal around the sound port while providing the shortest acoustic path for good sound quality. The sound port can also be routed to the device housing through a port in a rubber boot. This boot should be designed to seal the connection between the microphone’s lid and the rubber completely.

## **HANDLING INSTRUCTIONS**

### **PICK AND PLACE EQUIPMENT**

The MEMS microphone can be handled using standard pick-and-place and chip shooting equipment. Take care to avoid damage to the MEMS microphone structure as follows:

- Use a standard pickup tool to handle the microphone. Because the microphone hole is on the bottom of the package, the pickup tool can make contact with any part of the lid surface.
- Do not pick up the microphone with a vacuum tool that makes contact with the bottom side of the microphone. Do not pull air out of or blow air into the microphone port.
- Do not use excessive force to place the microphone on the PCB.

### **REFLOW SOLDER**

For best results, the soldering profile must be in accordance with the recommendations of the manufacturer of the solder paste used to attach the MEMS microphone to the PCB. It is recommended that the solder reflow profile not exceed the limit conditions specified in Figure 1 and Table 3.

### **BOARD WASH**

When washing the PCB, ensure that water does not make contact with the microphone port. Do not use blow-off procedures or ultrasonic cleaning.

OUTLINE DIMENSIONS

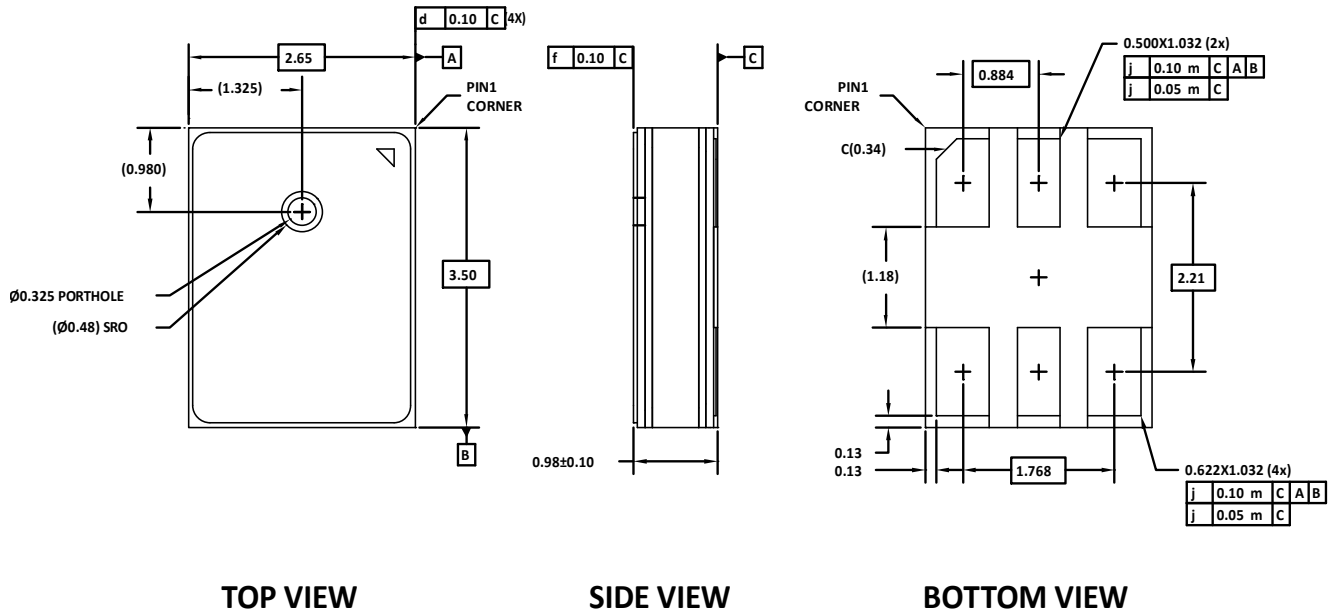

Figure 10. 4-Terminal Chip Array Small Outline No Lead Cavity  
 3.50 mm × 2.65 mm × 0.98 mm Body  
 Dimensions shown in millimeters

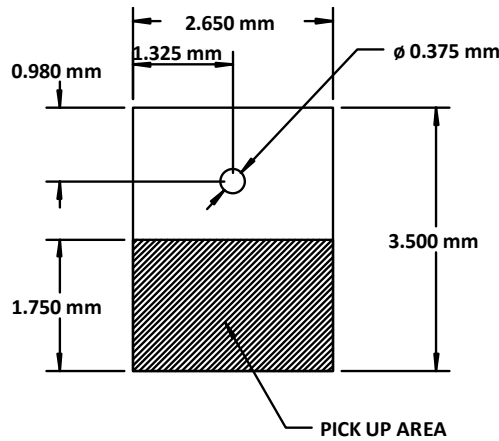

Figure 11. Recommended Vacuum Pick-up Area

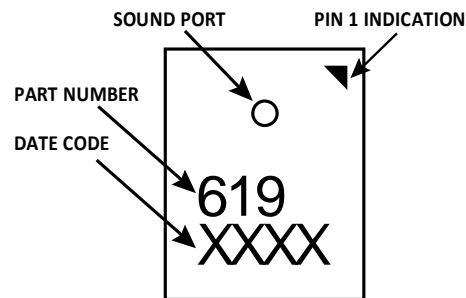

Figure 12. Package Marking Specification (Top View)

**ORDERING GUIDE**

<b>PART</b>	<b>TEMP RANGE</b>	<b>PACKAGE</b>	<b>QUANTITY</b>	<b>PACKAGING</b>
ICS-40619	-40°C to +85°C	6-Terminal LGA_CAV	10,000	13" Tape and Reel
EV_ICs-40619-FX	—	Flexible Evaluation Board	—	

**REVISION HISTORY**

REVISION DATE	REVISION	DESCRIPTION
4/19/2016	1.0	Initial Version

## **COMPLIANCE DECLARATION DISCLAIMER**

InvenSense believes the environmental and other compliance information given in this document to be correct but cannot guarantee accuracy or completeness. Conformity documents substantiating the specifications and component characteristics are on file. InvenSense subcontracts manufacturing, and the information contained herein is based on data received from vendors and suppliers, which has not been validated by InvenSense.

This information furnished by InvenSense is believed to be accurate and reliable. However, no responsibility is assumed by InvenSense for its use, or for any infringements of patents or other rights of third parties that may result from its use. Specifications are subject to change without notice. InvenSense reserves the right to make changes to this product, including its circuits and software, in order to improve its design and/or performance, without prior notice. InvenSense makes no warranties, neither expressed nor implied, regarding the information and specifications contained in this document. InvenSense assumes no responsibility for any claims or damages arising from information contained in this document, or from the use of products and services detailed therein. This includes, but is not limited to, claims or damages based on the infringement of patents, copyrights, mask work and/or other intellectual property rights.

Certain intellectual property owned by InvenSense and described in this document is patent protected. No license is granted by implication or otherwise under any patent or patent rights of InvenSense. This publication supersedes and replaces all information previously supplied. Trademarks that are registered trademarks are the property of their respective companies. InvenSense sensors should not be used or sold in the development, storage, production or utilization of any conventional or mass-destructive weapons or for any other weapons or life threatening applications, as well as in any other life critical applications such as medical equipment, transportation, aerospace and nuclear instruments, undersea equipment, power plant equipment, disaster prevention and crime prevention equipment.

©2016 InvenSense, Inc. All rights reserved. InvenSense, MotionTracking, MotionProcessing, MotionProcessor, MotionFusion, MotionApps, Digital Motion Processor, AAR and the InvenSense logo are trademarks of InvenSense, Inc. Other company and product names may be trademarks of the respective companies with which they are associated.



©2016 InvenSense, Inc. All rights reserved.

## Looking for pricing, stock, or lifecycle information?

Click below to explore more details on WIN SOURCE:

 [View ICS-40619](#) on WIN SOURCE

 [TDK InvenSense](#) Information

## Optimize Your Supply Chain with WIN SOURCE Solutions

-  Global Sourcing Solution
-  Obsolete Management
-  Cost Control Management
-  Shortage Management
-  Alternative Solution
-  Excess Inventory Management