



THE DATASHEET OF DC1728A



1.5A, Low Noise, Negative Linear Regulator with Precision Current Limit

DESCRIPTION

Demonstration circuit 1728A is an adjustable 1.5A negative linear regulator featuring the LT3015. This device supplies up to 1.5A of output current at a typical dropout voltage of 300mV. Operating quiescent current is typically 1.1mA and drops to <math>< 1\mu\text{A}</math> in shutdown. Quiescent current is also well controlled in dropout. In addition to fast transient response, the LT3015 exhibits very low output noise, making it ideal for noise-sensitive applications.

A key feature of the LT3015 is the capability to supply a wide output voltage range. The DC1728A can be set to -1.22V, -2.5V, -5.0V, -12.0V, -15.0V, as well as a user select option. In addition, the DC1728A is capable of delivering up to -1.5A output current, and can be used as a high current negative linear regulator, post regulator for switching supply, variable voltage supply or low output voltage power supply.

Internal protection circuitry includes reverse output protection, precision current limit with foldback and thermal limit with hysteresis.

The LT3015 is available as an adjustable device with a -1.22V reference voltage. Packages include the 5-lead TO-220 and DD-Pak, a thermally enhanced 12-lead MSOP and the low profile 8-lead 0.75mm × 3mm × 3mm DFN.

The LT3015 datasheet gives a complete description of the device, operation and application information. The datasheet should be read in conjunction with this quick start guide for working on or modifying the demo circuit 1728A.

Design files for this circuit board are available at <http://www.linear.com/demo>

LT, LT, LTC, LTM, Linear Technology and the Linear logo are registered trademarks of Linear Technology Corporation. All other trademarks are the property of their respective owners.

PERFORMANCE SUMMARY (T_A = 25°C)

SYMBOL	PARAMETER	CONDITIONS	MIN	TYP	MAX	UNITS
V _{IN}	Input Supply Range	V _{OUT} = -1.22V, I _{OUT1} = -1mA	-1.8		-30	V
V _{OUT}	Output Voltage	Shunt at 1, 2 for JP2	-1.183	-1.22	-1.257	V
V _{OUT}	Output Voltage	Shunt at 3, 4 for JP2	-2.425	-2.5	-2.575	V
V _{OUT}	Output Voltage	Shunt at 5, 6 for JP2	-4.85	-5.0	-5.15	V
V _{OUT}	Output Voltage	Shunt at 7, 8 for JP2	-11.64	-12.0	-12.36	V
V _{OUT}	Output Voltage	Shunt at 9, 10 for JP2	-14.55	-15.0	-15.45	V

DEMONSTRATION CIRCUIT 1728A QUICK START GUIDE

QUICK START PROCEDURE

Demonstration circuit 1728A is easy to set up to evaluate the performance of the LT3015. Refer to Figure 1 for proper measurement equipment setup and follow the procedure below:

NOTE. When measuring the input or output voltage ripple, care must be taken to avoid a long ground lead on the oscilloscope probe. Measure the input or output voltage ripple by touching the probe tip directly across the terminals of the input or output capacitors. See Figure 2 for proper scope probe technique.

1. Place JP1 on the ON position.

NOTE. Put JP1 = 1-2 for ON, JP1 = 1-4 for OFF, or JP1 = 1-3 for User Select.

2. Use JP2 to set the desired output voltage.

3. With power off, connect the input power supply to V_{IN} and GND.

4. Turn on the power at the V_{IN} .

NOTE. Make sure that the V_{IN} voltage does not exceed $-30V$.

5. Check for the proper output voltages.

NOTE. If there is no output, temporarily disconnect the load to make sure that the load is not set too high or is shorted.

6. Once the proper output voltages are established, adjust the loads within the operating range and observe the output voltage regulation, efficiency and other parameters.

NOTE. Make sure that the power dissipation is limited below the thermal limit.

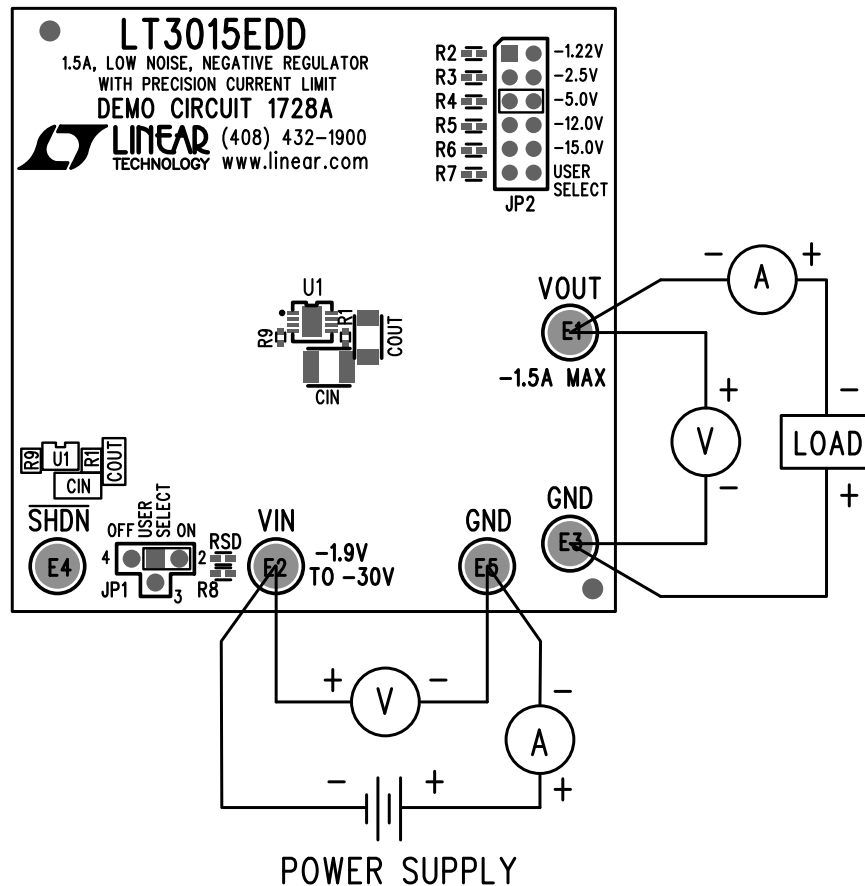

Figure 1. DC1728A Proper Equipment Setup

QUICK START PROCEDURE

Thermal Image

An example thermal image (Figure 3) shows the temperature distribution on the board. The test is done in still air at room temperature with 1.96W power dissipation in the LT3015. This gives the IC case-to-ambient thermal resistance $\theta_{JA} = 23^{\circ}\text{C}/\text{W}$ on the demo board.

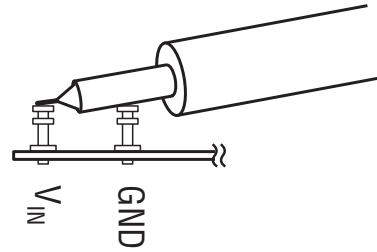

Figure 2. Measuring Input or Output Ripple

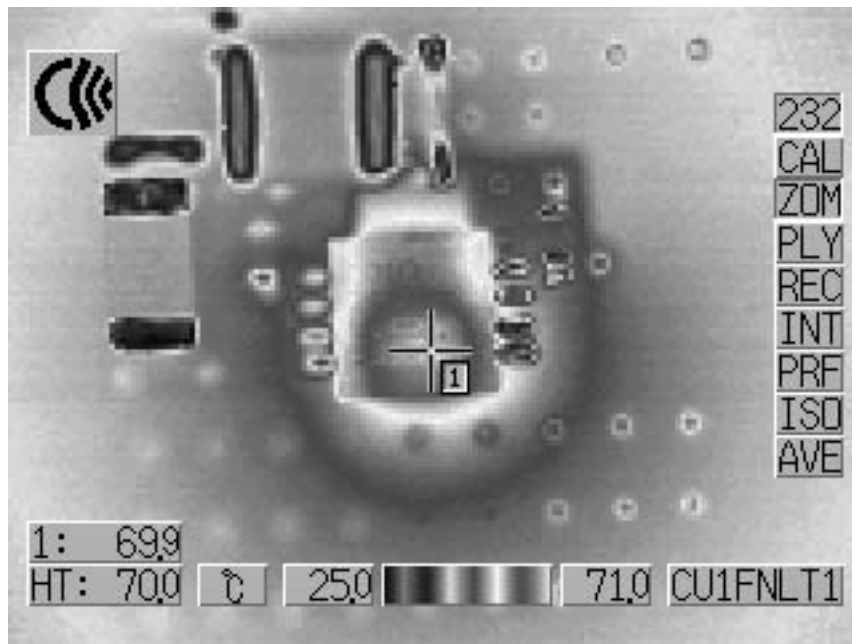

Figure 3. Temperature Rise at 1.96W Dissipation

DEMONSTRATION CIRCUIT 1728A QUICK START GUIDE

PARTS LIST

ITEM	QTY	REFERENCE	PART DESCRIPTION	MANUFACTURER/PART NUMBER
Required Circuit Components				
1	1	C _{IN}	CAP, X7R, 10µF 50V, 10%, 1210	MURATA, GRM32ER71H106K
2	1	C _{OUT}	CAP, X7R, 10µF 25V, 10%, 1206	MURATA, GRM31CR71E106KA12L
3	1	R1	RES., CHIP, 3.48k, 1/16W, 1% 0402	VISHAY, CRCW04023K48FKED
4	2	R2, RSD	RES., CHIP, 0Ω, 0402	VISHAY, CRCW04020000Z0ED
5	1	R3	RES., CHIP, 3.65k, 1/16W, 1% 0402	VISHAY, CRCW04023K65FKED
6	1	R4	RES., CHIP, 11.0k, 1/16W, 1% 0402	VISHAY, CRCW040211K0FKED
7	1	R5	RES., CHIP, 30.9k, 1/16W, 1% 0402	VISHAY, CRCW040230K9FKED
8	1	R6	RES., CHIP, 39.2k, 1/16W, 1% 0402	VISHAY, CRCW040239K2FKED
9	1	R9	RES., CHIP, 100k, 1/16W, 1% 0402	VISHAY, CRCW0402100KFKED
		U1	I.C., LT3015EDD, DFN8DD	LINEAR TECH., LT3015EDD
Additional Demo Board Circuit Components				
1	1	C1	CAP, ALUM., 10µF 50V, CE-BSS	SUNCON, 50CE10BSS
2	0	C2	CAP, 7343	
3	0	R7, R8	RES., CHIP, 0402	
Hardware-For Demo Board Only				
1	5	E1-E5	TP, TURRET, 0.094"	MILL-MAX, 2501-2-00-80-00-00-07-0
2	1	JP1	JMP, 4 PINS, 0.079"	SAMTEC, ASP-157349-01
3	1	JP2	JMP, 2 × 6, 0.079"	SAMTEC, TMM-106-02-L-D
4	2	XJP1, XJP2	SHUNT, .079" CENTER	SAMTEC, 2SN-BK-G

DEMONSTRATION CIRCUIT 1728A QUICK START GUIDE

DEMONSTRATION BOARD IMPORTANT NOTICE

Linear Technology Corporation (LTC) provides the enclosed product(s) under the following **AS IS** conditions:

This demonstration board (DEMO BOARD) kit being sold or provided by Linear Technology is intended for use for **ENGINEERING DEVELOPMENT OR EVALUATION PURPOSES ONLY** and is not provided by LTC for commercial use. As such, the DEMO BOARD herein may not be complete in terms of required design-, marketing-, and/or manufacturing-related protective considerations, including but not limited to product safety measures typically found in finished commercial goods. As a prototype, this product does not fall within the scope of the European Union directive on electromagnetic compatibility and therefore may or may not meet the technical requirements of the directive, or other regulations.

If this evaluation kit does not meet the specifications recited in the DEMO BOARD manual the kit may be returned within 30 days from the date of delivery for a full refund. **THE FOREGOING WARRANTY IS THE EXCLUSIVE WARRANTY MADE BY THE SELLER TO BUYER AND IS IN LIEU OF ALL OTHER WARRANTIES, EXPRESSED, IMPLIED, OR STATUTORY, INCLUDING ANY WARRANTY OF MERCHANTABILITY OR FITNESS FOR ANY PARTICULAR PURPOSE. EXCEPT TO THE EXTENT OF THIS INDEMNITY, NEITHER PARTY SHALL BE LIABLE TO THE OTHER FOR ANY INDIRECT, SPECIAL, INCIDENTAL, OR CONSEQUENTIAL DAMAGES.**

The user assumes all responsibility and liability for proper and safe handling of the goods. Further, the user releases LTC from all claims arising from the handling or use of the goods. Due to the open construction of the product, it is the user's responsibility to take any and all appropriate precautions with regard to electrostatic discharge. Also be aware that the products herein may not be regulatory compliant or agency certified (FCC, UL, CE, etc.).

No License is granted under any patent right or other intellectual property whatsoever. **LTC assumes no liability for applications assistance, customer product design, software performance, or infringement of patents or any other intellectual property rights of any kind.**

LTC currently services a variety of customers for products around the world, and therefore this transaction **is not exclusive**.

Please read the DEMO BOARD manual prior to handling the product. Persons handling this product must have electronics training and observe good laboratory practice standards. **Common sense is encouraged.**

This notice contains important safety information about temperatures and voltages. For further safety concerns, please contact a LTC application engineer.



Mailing Address:

Linear Technology
1630 McCarthy Blvd.
Milpitas, CA 95035

Copyright © 2004, Linear Technology Corporation

Looking for pricing, stock, or lifecycle information?

Click below to explore more details on WIN SOURCE:

-  [View DC1728A on WIN SOURCE](#)
-  [Analog Devices Inc. Information](#)

Optimize Your Supply Chain with WIN SOURCE Solutions

-  Global Sourcing Solution
-  Obsolete Management
-  Cost Control Management
-  Shortage Management
-  Alternative Solution
-  Excess Inventory Management