



### FEATURES

#### Analog input/output

- 16-bit, 400 kSPS ADC
- Voltage, current, and impedance measurement capability
  - Internal and external current and voltage channels
  - Ultralow leakage switch matrix and input mux
  - Input buffers, PGA

#### Voltage DACs

- Two dual output voltage DACs
  - Output range: 0.2 V to 2.4 V ( $\pm 2.2$  V voltage potential to sensor) for 12-bit outputs
- Two bias potentiostat and TIA amplifiers
  - Ultralow power, 1  $\mu$ A per amplifier
- One high speed 12-bit voltage DAC
  - Output range to sensor:  $-607$  mV to  $+607$  mV
  - High speed TIA for impedance measurements
  - Programmable gain amplifier on output

#### Amplifiers, accelerators, and references

- Two low power, low noise amplifiers
  - Suitable for potentiostat bias in electrochemical sensing
- Two low power, low noise TIAs
  - Suitable for measuring sensor current output in the  $\pm 0.00005$   $\mu$ A to  $\pm 3000$   $\mu$ A range
  - Programmable load and gain resistors

#### Analog hardware accelerators

- Digital waveform generator (refer to the [ADuCM355 Hardware Reference Manual](#))
- DFT and digital filters

#### 2.5 V and 1.82 V on-chip, precision voltage references

#### Internal temperature sensor, $\pm 2^\circ\text{C}$ accurate

- Impedance measurement range of  $< 1$   $\Omega$  to 10 M $\Omega$ , 0.016 Hz to 200,000 Hz

#### Voltammetry scan rate up to 2000 steps per second

#### Microcontroller

- 26 MHz Arm Cortex-M3 processor
- Serial wire port supports code download and debugging
- 128 kB flash/64 kB of SRAM

#### Security and safety

- Hardware cyclic redundancy check (CRC) with programmable polynomial generator (refer to the [ADuCM355 Hardware Reference Manual](#))
- Read and write protection of user flash

#### On-chip peripherals

- UART, I<sup>2</sup>C, and SPI serial input/output
- Up to 17 GPIO pins

#### External interrupt option

- General-purpose, wake-up, and watchdog timers

#### Power

- 2.8 V to 3.6 V supply and active measurement range
- Power supply monitor
- Active current consumption: 30  $\mu$ A/MHz for digital section
- Hibernate with bias to external sensor: 8.5  $\mu$ A
- Shutdown mode with no SRAM retention: 2  $\mu$ A

#### Package and temperature range

- 6 mm  $\times$  5 mm, 72-lead LGA package
- Fully specified for  $-40^\circ\text{C}$  to  $+85^\circ\text{C}$  ambient operation

### APPLICATIONS

- Gas detection
- Food quality
- Environmental sensing (air, water, and soil)
- Blood glucose meters
- Life sciences and biosensing analysis
- Bioimpedance measurements
- General amperometry, voltammetry, and impedance spectroscopy functions

### SIMPLIFIED FUNCTIONAL BLOCK DIAGRAM

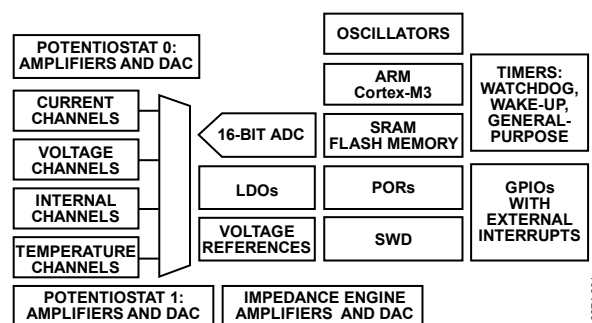

Figure 1.

## TABLE OF CONTENTS

Features .....	1	Absolute Maximum Ratings .....	19
Applications .....	1	Thermal Resistance .....	19
Simplified Functional Block Diagram .....	1	ESD Caution .....	19
Revision History .....	2	Pin Configuration and Function Descriptions .....	20
Functional Block Diagram .....	3	Typical Performance Characteristics .....	24
General Description .....	4	Applications Information .....	26
Specifications .....	5	Recommended Circuit and Component Values .....	26
Microcontroller Electrical Specifications .....	5	Outline Dimensions .....	28
RMS Noise Resolution of ADC .....	15	Ordering Guide .....	28
Timing Specifications .....	16		

## REVISION HISTORY

### 4/2020—Rev. B to Rev. C

Change to Figure 19 .....	27
---------------------------	----

### 6/2019—Rev. A to Rev. B

Changes to Figure 2 .....	3
Changes to Table 1 .....	9
Changes to RMS Noise Resolution of ADC Section and Table 3 .....	15

Changes to Figure 7 .....	20
Change to Table 8 .....	22
Added Figure 16 and Figure 17; Renumbered Sequentially .....	25
Changes to Figure 19 .....	27

### 4/2019—Rev. 0 to Rev. A

Changes to Table 8 .....	21
--------------------------	----

### 3/2019—Revision 0: Initial Version

# FUNCTIONAL BLOCK DIAGRAM

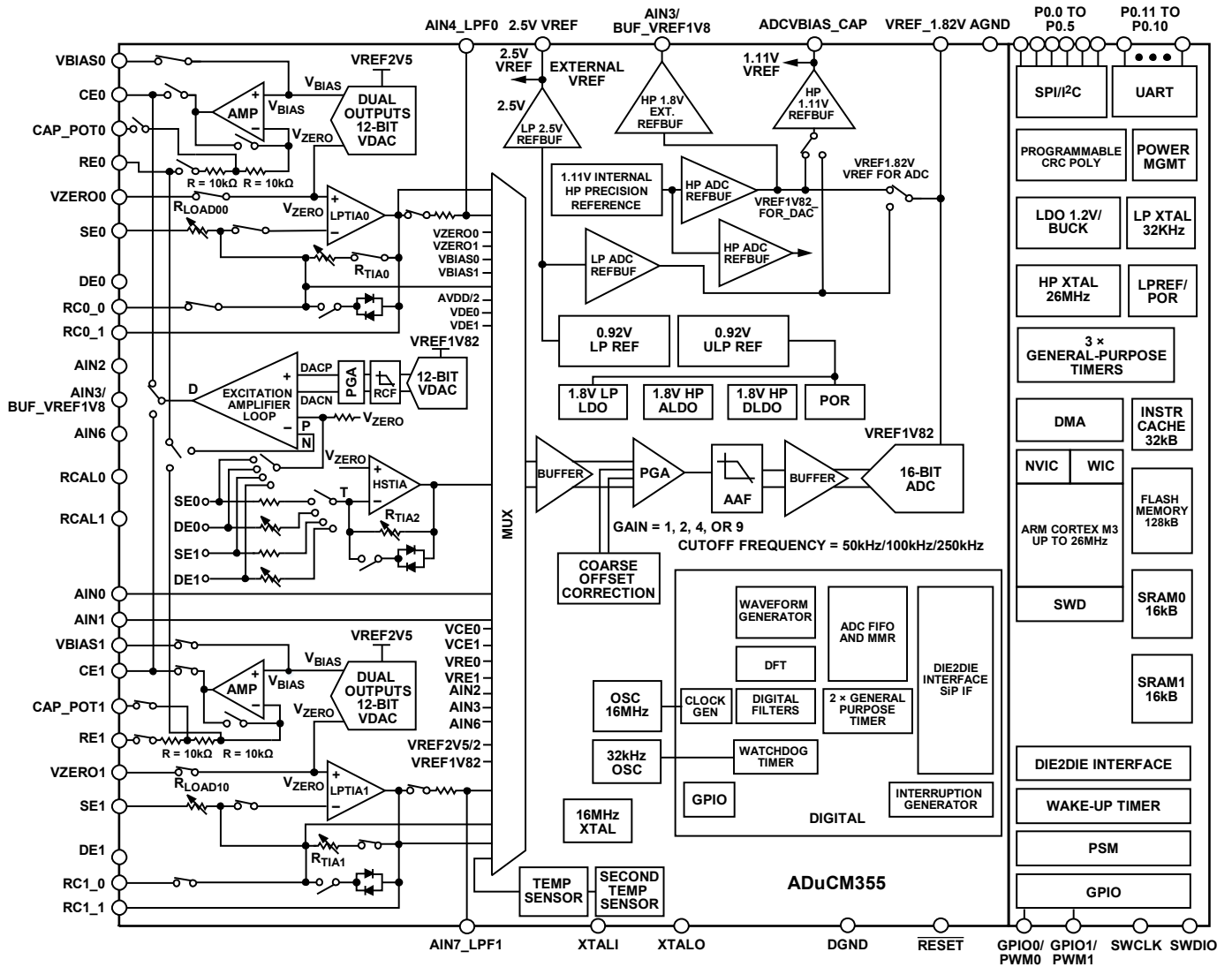

NOTES  
 1. THROUGHOUT THIS DATA SHEET, MULTIFUNCTION PINS, SUCH AS P0.0/SPI0. CLK, ARE REFERRED TO EITHER BY THE ENTIRE PIN NAME OR BY A SINGLE FUNCTION OF THE PIN, FOR EXAMPLE, P0.0, WHEN ONLY THAT FUNCTION IS RELEVANT.

Figure 2.

16874-101

## GENERAL DESCRIPTION

The ADuCM355 is an on-chip system that controls and measures electrochemical sensors and biosensors. The ADuCM355 is an ultralow power, mixed-signal microcontroller based on the Arm® Cortex™-M3 processor. The device features current, voltage, and impedance measurement capability.

The ADuCM355 features a 16-bit, 400 kSPS, multichannel successive approximation register (SAR) analog-to-digital converter (ADC) with input buffers, built-in antialias filter (AAF), and programmable gain amplifier (PGA). The current inputs include three transimpedance amplifiers (TIA) with programmable gain and load resistors for measuring different sensor types. The analog front end (AFE) also contains two low power amplifiers designed specifically for potentiostat capability to maintain a constant bias voltage to an external electrochemical sensor. The noninverting inputs of these two amplifiers are controlled by on-chip, dual output digital-to-analog converters (DACs). The analog outputs include a high speed DAC and output amplifier designed to generate an ac signal.

The ADC operates at conversion rates up to 400 kSPS with an input range of  $-0.9\text{ V}$  to  $+0.9\text{ V}$ . An input mux before the ADC allows the user to select an input channel for measurement. These input channels include three external current inputs, multiple external voltage inputs, and internal channels. The internal channels allow diagnostic measurements of the internal supply voltages, die temperature, and reference voltages.

Two of the three voltage DACs are dual output, 12-bit string DACs. One output per DAC controls the noninverting input of a potentiostat amplifier, and the other controls the noninverting input of the TIA.

The third DAC (sometimes referred to as the high speed DAC) is designed for the high power TIA for impedance measurements. The output frequency range of this DAC is up to 200 kHz.

A precision 1.82 V and 2.5 V on-chip reference source is available. The internal ADC and voltage DAC circuits use this on-chip reference source to ensure low drift performance for all peripherals.

The ADuCM355 integrates a 26 MHz Arm Cortex-M3 processor, which is a 32-bit reduced instruction set computer (RISC)

machine. The Arm Cortex-M3 processor also has a flexible multichannel direct memory access controller (DMA) supporting two independent serial peripheral interface (SPI) ports, universal asynchronous receiver/transmitter (UART), and I<sup>2</sup>C communication peripherals. The ADuCM355 has 128 kB of nonvolatile flash/EE memory and 64 kB of single random access memory (SRAM) integrated on-chip.

The digital processor subsystem is clocked from a 26 MHz on-chip oscillator. The oscillator is the source of the main digital die system clock. Optionally, a 26 MHz phase-locked loop (PLL) can be used as the digital system clock. This clock can be internally subdivided so that the processor operates at a lower frequency and saves power. A low power, internal 32 kHz oscillator is available and can clock the timers. The ADuCM355 includes three general-purpose timers, a wake-up timer (which can be used as a general-purpose timer), and a system watchdog timer.

The analog subsystem has a separate 16 MHz oscillator used to clock the ADC, DACs, and other digital logic on the analog die. The analog die also contains a separate 32 kHz, low power oscillator to clock a watchdog timer on the analog die. Both the 32 kHz oscillator and this watchdog are independent from the digital die oscillators and system watchdog timer.

A range of communication peripherals can be configured as required in a specific application. These peripherals include UART, I<sup>2</sup>C, two SPI ports, and general-purpose input/output (GPIO) ports. The GPIOs, combined with the general-purpose timers, can be combined to generate a pulse-width modulation (PWM) type output.

Nonintrusive emulation and program download are supported via the serial wire debug port (SW-DP) interface.

The ADuCM355 operates from a 2.8 V to 3.6 V supply and is specified over a temperature range of  $-40^{\circ}\text{C}$  to  $+85^{\circ}\text{C}$ . The chip is packaged in a 72-lead, 6 mm  $\times$  5 mm land grid array (LGA) package.

Note that, throughout this data sheet, multifunction pins, such as P0.0/SPIO\_CLK, are referred to either by the entire pin name or by a single function of the pin, for example, P0.0, when only that function is relevant.

# SPECIFICATIONS

## MICROCONTROLLER ELECTRICAL SPECIFICATIONS

AVDD = DVDD = 2.8 V to 3.6 V, maximum difference between supplies = 0.3 V, ADC reference and excitation DAC and amplifier = 1.82 V internal reference, low power VBIASx and VZEROx DAC reference = 2.5 V internal reference, central processing unit (CPU) speed ( $f_{CORE}$ ) = 26 MHz,  $T_A = -40^{\circ}\text{C}$  to  $+85^{\circ}\text{C}$ , buck convertor on digital die disabled, unless otherwise noted.

Table 1.

Parameter	Symbol	Min	Typ	Max	Unit	Test Conditions/Comments
<b>ADC SPECIFICATIONS</b>						
Data Rate <sup>1</sup>	$f_{SAMPLE}$			400	kSPS	Pseudo differential mode measured relative to ADCVBIAS_CAP pin voltage (1.82 V) unless otherwise stated, specifications based on high speed mode unless otherwise stated, ADC voltage channel calibrated in production with PGA gain = 1.5, AFE die analog clock (ACLK) = 32 MHz or 16 MHz unless otherwise stated
	$f_{SAMPLE}$			200	kSPS	High speed mode, decimation factor of 4
Resolution <sup>1</sup>		16			Bits	Normal mode, decimation factor of 4
Integral Nonlinearity <sup>1</sup>	INL	-4	±2.0	+4.0	LSB	Number of data bits
		-5.6	±2.0	+4.7	LSB	PGA Gain = 1.5, 1.82 V internal reference, 1 LSB <sup>2</sup> = (1.82 V/2 <sup>15</sup> )/PGA gain
			±2.0		LSB	PGA gain = 9, 1.82 V internal reference
Differential Nonlinearity (No Missing Codes) <sup>1</sup>	DNL	-0.99	±0.9	+2.5	LSB	1.82 V external reference, 1 LSB <sup>2</sup> = (1.82 V/2 <sup>15</sup> )/PGA gain
DC Code Distribution <sup>3</sup>			±6		LSB	1.82 V internal reference, 1 LSB <sup>2</sup> = (1.82 V/2 <sup>15</sup> )/PGA gain
			±6		LSB	Minimum and maximum range from mean ADC codes for 1000 ADC samples, PGA gain = 1.5, low power mode, ADC input 0.9 V, ADC output data rate = 200 kSPS, 1 LSB <sup>2</sup> = (1.82 V/2 <sup>15</sup> )/PGA gain
			±6		LSB	Input channel is low power TIA $I_{TIA} = 1 \mu\text{A}$ , TIA resistor ( $R_{TIA}$ ) = 512 k $\Omega$ , load resistor ( $R_{LOAD}$ ) = 10 $\Omega$ , ADC output data rate = 200 kSPS
			±6		LSB	Input channel is high power TIA (HPTIA) = 1 $\mu\text{A}$ , $R_{TIA} = 10 \text{ k}\Omega$ , $R_{LOAD} = 100 \Omega$ , ADC output data rate = 200 kSPS
<b>ADC ENDPOINT ERRORS</b>						
Offset Error		-600	±200	+600	$\mu\text{V}$	For AIN0 to AIN7_LPF1 inputs, 200 kSPS ADC update rate, sinc3 filter enabled
		-620	±200	+880	$\mu\text{V}$	PGA gain = 1.5, low power mode, all channels except AIN3
High Power Mode <sup>4</sup>		-1.1	±0.5	+1.4	mV	PGA gain = 1.5, low power mode, AIN3 only
Drift <sup>1</sup>			±3		$\mu\text{V}/^{\circ}\text{C}$	PGA gain = 1.5, high power mode
Offset Matching			±2		LSB	Using 1.82 V internal reference
Full-Scale Error		-750	±400	+940	$\mu\text{V}$	Matching compared to AIN3
						Excluding internal channels, both negative and positive full scale, error at both endpoints, PGA gain = 1.5, low power mode
High Power Mode <sup>4</sup>		-1.6	±0.8	+1.82	mV	PGA gain = 1.5, high power mode
Internal Channels <sup>1</sup>			0.2	0.75	% of full scale	AVDD/2, DVDD/2, ADCVBIAS_CAP, VREF_2.5V, VREF_1.8V, AVDD_REG
Gain Drift <sup>1</sup>		-3	±1	+3	$\mu\text{V}/^{\circ}\text{C}$	Full-scale error drift minus offset error drift
Gain Error Matching			±3		LSB	Mismatch from channel to channel

Parameter	Symbol	Min	Typ	Max	Unit	Test Conditions/Comments
PGA Mismatch Error <sup>1</sup>						
PGA Gain Mismatch Drift			1.5		μV/°C	Drift after calibration
Uncalibrated PGA Gain Mismatch			4		%	Production devices only calibrated for PGA gain = 1.5
Uncalibrated PGA Gain Mismatch Drift			10		μV/°C	Uncalibrated drift
<b>ADC DYNAMIC PERFORMANCE</b>						
Signal-to-Noise Ratio	SNR		80		dB	Input signal frequency ( $f_{in}$ ) = 20 kHz sine wave, $f_{SAMPLE} = 200$ kSPS, using AINx voltage input channels, PGA gain = 1.5 Includes distortion and noise components
			76		dB	PGA gain = 1, 1.5, and 2
			70		dB	PGA gain = 4
Total Harmonic Distortion <sup>1</sup>	THD		-84		dB	PGA gain = 9
Peak Harmonic or Spurious Noise <sup>1</sup>			-86		dB	
Channel to Channel Crosstalk <sup>1</sup>			-86		dB	Measured on adjacent channels
Noise (RMS) <sup>1,5</sup>		See Table 2				0.1 Hz to 10 Hz
			800		nV/√Hz	Chop off
			400		nV/√Hz	Chop on
<b>ADC INPUT</b>						
Input Voltage Ranges <sup>1</sup>		0.2		2.1	V	Input to ADC mux
Pseudo Differential Voltage						Voltage applied to any input pin
		-0.9		+0.9	V	Between ADCBIAS_CAP pin voltage (1.82 V) and analog input from mux
		-0.9		+0.9	V	Gain = 1
		-0.6		+0.6	V	Gain = 1.5
		-0.3		+0.3	V	Gain = 2
		-0.133		+0.133	V	Gain = 4
Input Range <sup>1</sup>		±0.00005		±3000	μA	Gain = 9 Low power TIA 0, low power TIA 1, and HPTIA current input channel ranges
Common-Mode Range <sup>1</sup>		0.2	1.1	2.1	V	
Leakage Current		-1.5	±0.5	+1.5	nA	AIN0 to AIN7_LPF1, SE0, and SE1 pins (exclusive of DE0 and DE1 pins)
			±2		nA	DE0 and DE1 pins only, see Figure 14
Input Current <sup>1</sup>		-8	±2	+8	nA	AIN0 to AIN7_LPF1, SE0, SE1, and DE0 pins
Input Capacitance			40		pF	During ADC acquisition
AAF, 3 dB Frequency Range						3 programmable settings
Mode 0			50		kHz	
Mode 1			100		kHz	
Mode 2			250		kHz	
ADC Channel Switch Settling Time						Time delay required after switching ADC input channel, excludes sinc3 settling time
AAF, 3 dB Cutoff Frequency <sup>1</sup>						
250 kHz		25			μs	
100 kHz		40			μs	
50 kHz		60			μs	

Parameter	Symbol	Min	Typ	Max	Unit	Test Conditions/Comments
<b>DISCRETE FOURIER TRANSFORM (DFT)-BASED IMPEDANCE MEASUREMENTS</b>						
Accuracy						For impedance (Z) of 1 k $\Omega$ (0.02% tolerant resistor), excitation frequency = 0.1 Hz to 200 kHz, sine amplitude = 10 mV rms, R <sub>TIA</sub> = 5 k $\Omega$ , R <sub>CALx</sub> = 200 $\Omega$ , 1% accurate temperature coefficient 5 ppm/ $^{\circ}$ C, single DFT measurement, DFT using 8192 ADC samples, Hanning on, HSDACCON, Bits[8:1] = 0x1B for low power mode and impedance measurements $\leq$ 80 kHz, HSDACCON, Bits[8:1] = 0x7 for high power mode and impedance measurements > 80 Hz
Magnitude		-1.25	$\pm$ 0.2	+1.25	%	20 kHz to 200 kHz
			$\pm$ 0.2		%	10 Hz to 20 kHz
			$\pm$ 1		%	1 Hz to <10 Hz
Phase		-0.3	$\pm$ 0.1	+0.3	Degrees	
Three Resistor Star Cell						Z = 2.2 $\Omega$ connected, see Figure 18
Accuracy						0.1 Hz to 200 kHz
Magnitude			$\pm$ 0.5		%	
Phase			$\pm$ 0.5		Degrees	
Accuracy						Z = 100 $\Omega$ connected, 0.1 Hz to 200 kHz, see Figure 18
Magnitude			$\pm$ 0.2		%	
Phase			$\pm$ 0.2		Degrees	
High Speed Loop						See Figure 18
Allowed External Load				100	pF	R <sub>2</sub> + R <sub>3</sub> $\leq$ 200 $\Omega$ , R <sub>1</sub> $\leq$ 100 $\Omega$ , for excitation frequencies $\geq$ 1 kHz
Capacitance <sup>1</sup>				50	pF	R <sub>2</sub> + R <sub>3</sub> $\leq$ 1 k $\Omega$ , R <sub>1</sub> $\leq$ 500 $\Omega$ , for excitation frequencies $\geq$ 1 kHz
				40	pF	R <sub>2</sub> + R <sub>3</sub> $\leq$ 1.6 k $\Omega$ , R <sub>1</sub> $\leq$ 800 $\Omega$ , for excitation frequencies $\geq$ 1 kHz
Excitation Amplifier Bandwidth			3		MHz	
Impedance Frequency Range <sup>1</sup>		0.016		200,000	Hz	
Impedance Measurement Range <sup>1</sup>		0.4		10,000	$\Omega$	
<b>LOW POWER TIA AND POTENTIOSTAT AMPLIFIERS</b>						
Input Bias Current			80	300	pA	TIA, SEx pin
			20	150	pA	Potentiostat amplifiers, REx pin
Offset Voltage			50	150	$\mu$ V	
Offset Voltage Drift vs. Temperature			1		$\mu$ V/ $^{\circ}$ C	
Noise						Unity-gain mode, rms voltage in 0.1 Hz to 10 Hz range
			1.6		$\mu$ V rms	Normal mode (LPTIACONx Bit 2 = 0)
			2		$\mu$ V rms	Half power mode (LPTIACONx Bit 2 = 1)
Potentiostat Source and Sink Current <sup>1</sup>		-750		+750	$\mu$ A	Normal mode (LPTIACONx, Bits[4:3] = 00), from CEx pins
		-3		+3	mA	High current mode (LPTIACONx, Bits[4:3] = 01 or 11), from CEx pins
DC Power Supply Rejection Ratio	DC PSRR		70		dB	At REx pin, R <sub>TIA</sub> = 256 k $\Omega$ , R <sub>LOAD</sub> = 10 $\Omega$
Input Common-Mode Voltage Range <sup>1</sup>		300		AVDD - 600	mV	
Output Voltage Range <sup>1</sup>		300		AVDD - 400	mV	Normal mode (LPTIACONx, Bits[4:3] = 00), sink and source 750 $\mu$ A
		300		AVDD - 400	mV	High current mode (LPTIACONx, Bits[4:3] = 01/11), sink and source 3 mA

Parameter	Symbol	Min	Typ	Max	Unit	Test Conditions/Comments
Overcurrent Limit Protection			20		mA	Amplifiers try to limit source and sink current to this value via internal clamp
Allowed Duration of Overcurrent Limit <sup>1</sup>				5	sec	User must limit duration of overcurrent condition to less than this value or risk damaging amplifier
Allowed Frequency of Overcurrent Conditions				1	Per hour	
Short-Circuit Current			12		mA	When amplifier output is shorted to ground
<b>PROGRAMMABLE RESISTORS</b>						
Low Power TIA R <sub>LOAD</sub> on SE0, SE1 Inputs <sup>1</sup>						
Drift over Temperature			±200		ppm/°C	10 Ω, 30 Ω, 100 Ω, 1500 Ω, 3000 Ω, 3500 Ω
0 Ω R <sub>LOAD</sub> Accuracy	0.01	0.08	0.15		Ω	50 Ω
10 Ω R <sub>LOAD</sub> Accuracy	9.8	11.7	13.5		Ω	
30 Ω R <sub>LOAD</sub> Accuracy	28	33.8	39		Ω	
50 Ω R <sub>LOAD</sub> Accuracy	48	55	63		Ω	
100 Ω R <sub>LOAD</sub> Accuracy	88	110	130		Ω	
Low Power TIA R <sub>TIA</sub> Gain on SE0, SE1 Inputs <sup>1</sup>						
Accuracy	-5		+15		%	User programmable, includes 1 kΩ, 2 kΩ, 3 kΩ, 4 kΩ, 6 kΩ, 8 kΩ, 10 kΩ, 16 kΩ, 20 kΩ, 22 kΩ, 30 kΩ, 40 kΩ, 64 kΩ, 100 kΩ, 128 kΩ, 160 kΩ, 192 kΩ, 256 kΩ, 512 kΩ
Drift over Temperature	115	120	130		Ω	200 Ω setting with R <sub>LOAD</sub> = 100 Ω
Low Power TIA R <sub>TIA</sub> Mismatch Error <sup>1</sup>			±100		ppm/°C	Error when moving up or down one R <sub>TIA</sub> value
	-0.6	+0.2	+0.6		%	512 kΩ to 2 kΩ range excluding 40 kΩ
	-3.5	+0.5	+3.5		%	40 kΩ (up to 48 kΩ, down to 32 kΩ)
		±20			%	200 Ω
HPTIA R <sub>LOAD</sub> on SE0, SE1 Inputs <sup>1</sup>						
Accuracy	102	110	116		Ω	Fixed 100 Ω target setting
Drift		±160			ppm/°C	
HPTIA R <sub>TIA</sub> Gain on SE0, SE1 Inputs <sup>1</sup>						R <sub>TIA02</sub> and R <sub>TIA04</sub>
Accuracy		±20			%	User programmable, includes 0.2 kΩ, 1 kΩ, 5 kΩ, 10 kΩ, 20 kΩ, 40 kΩ, 80 kΩ, 160 kΩ
Drift		±200			ppm/°C	
HPTIA R <sub>LOAD</sub> on DE0, DE1 Inputs <sup>1</sup>						R <sub>LOAD03</sub> and R <sub>LOAD05</sub>
Accuracy	0.001		0.15		Ω	0 Ω setting
	5		10.7		Ω	10 Ω setting
	26.5	32.6	37.6		Ω	30 Ω setting
		±20			%	30 Ω, 50 Ω, and 100 Ω settings
Drift over Temperature		±0.2			%/°C	10 Ω setting
		±200			ppm/°C	Excludes R <sub>LOAD</sub> = 0 Ω and 10 Ω
HPTIA R <sub>TIA</sub> Gain on DE0, DE1 Inputs <sup>1</sup>						User programmable, includes 0.1 kΩ, 0.2 kΩ, 1 kΩ, 5 kΩ, 10 kΩ, 20 kΩ, 40 kΩ, 80 kΩ, 160 kΩ
Accuracy	120	135	150		Ω	100 Ω setting
	230	250	290		Ω	200 Ω setting
		±20			%	1 kΩ, 5 kΩ, 10 kΩ, 20 kΩ, 40 kΩ, 80 kΩ, 160 kΩ
Drift over Temperature		±350			ppm/°C	100 Ω, 200 Ω settings
		±200			ppm/°C	1 kΩ, 5 kΩ, 10 kΩ, 20 kΩ, 40 kΩ, 80 kΩ, 160 kΩ

Parameter	Symbol	Min	Typ	Max	Unit	Test Conditions/Comments	
HPTIA $R_{TIA}$ Mismatch Error SE0, SE1, DE0, and DE1 <sup>1</sup>		-3.5 -2.5	+1 $\pm 2$	+3.5 +5	% %	Error introduced when moving up or down one $R_{TIA}$ value 160 k $\Omega$ to 5 k $\Omega$ range 1 k $\Omega$ , 200 $\Omega$ , and 100 $\Omega$	
<b>HPTIA AMPLIFIER</b>							
Bias Current			1		nA	Ensure $R_{TIA}$ selection generates output voltage of less than $\pm 900$ mV with PGA gain = 1  Amplifier tries to limit source and sink current to this value via internal clamp, tested with $R_{LOAD} = 0 \Omega$ , $R_{TIA} = 100 \Omega$	
Maximum Current Sink and Source <sup>1</sup>		-3		+3	mA		
Input Common-Mode Voltage Range <sup>1</sup>		300		AVDD - 700	mV		
Output Voltage Range <sup>1</sup>		200		AVDD - 400	mV		
Overcurrent Limit Protection <sup>1</sup>			17		mA		
Allowed Duration of Overcurrent Limit <sup>1</sup>				5	sec		
Allowed Frequency of Overcurrent Conditions <sup>1</sup>				1	Per hour		
Short-Circuit Current			30		mA		
<b>LOW POWER ON-CHIP VOLTAGE REFERENCE</b>							
Accuracy				$\pm 5$	mV		0.47 $\mu$ F from VREF_2.5V to AGND, reference is measured with all low power voltage DACs and output amplifiers enabled $T_A = 25^\circ\text{C}$ Peak-to-peak voltage in 0.1 Hz to 10 Hz range  DC variation due to AVDD supply changes AC 1 kHz, 50 mV peak-to-peak ripple applied to AVDD supply
Noise <sup>1</sup>			60		$\mu$ V p-p		
Reference Temperature Coefficient <sup>1,6</sup>		-25	$\pm 10$	+25	ppm/ $^\circ\text{C}$		
DC Power Supply Rejection Ratio	DC PSRR		70		dB		
AC Power Supply Rejection Ratio <sup>7</sup>	AC PSRR		48		dB		
Long-Term Stability <sup>8</sup>			100		ppm/1000 hr		
<b>HIGH POWER REFERENCES</b>							
High Power On-Chip Voltage Reference			1.82		V	4.7 $\mu$ F from VREF_1.82V to AGND, reference is measured with ADC enabled $T_A = 25^\circ\text{C}$  DC variation due to AVDD supply changes AC 1 kHz, 50 mV peak-to-peak ripple applied to AVDD supply 470 nF from ADCVBIAS_CAP to AGND, reference is measured with ADC enabled $T_A = 25^\circ\text{C}$  DC variation due to AVDD supply changes AC 1 kHz, 50 mV peak-to-peak ripple applied to AVDD supply	
Accuracy				$\pm 5$	mV		
Reference Temperature Coefficient <sup>1,2</sup>		-20	$\pm 5$	+20	ppm/ $^\circ\text{C}$		
DC Power Supply Rejection Ratio	DC PSRR		85		dB		
AC Power Supply Rejection Ratio <sup>9</sup>	AC PSRR		60		dB		
ADC Common Mode Reference Source			1.11		V		
Accuracy				$\pm 5$	mV		
Reference Temperature Coefficient <sup>1</sup>		-20	$\pm 5$	+20	ppm/ $^\circ\text{C}$		
DC Power Supply Rejection Ratio	DC PSRR		80		dB		
AC Power Supply Rejection Ratio	AC PSRR		60		dB		
Long-Term Stability			100		ppm/1000 hr		

Parameter	Symbol	Min	Typ	Max	Unit	Test Conditions/Comments
BUFFERED REFERENCE VOLTAGE OUTPUT			1.82		V	
Accuracy				±5	mV	$T_A = 25^\circ\text{C}$ , capacitive load to ground 100 pF
Reference Temperature Coefficient <sup>1,5</sup>		-20		+20	ppm/°C	
Output Impedance			0.5	1	Ω	
Load Current <sup>1</sup>				200	μA	
LOW POWER DAC SPECIFICATIONS (VBIASx/VZEROx)						VBIASx specifications derived from measurements taken with potentiostat amplifier in unity-gain mode and measured at CE0 and CE1 pins, VZEROx specifications derived from measurements at VZERO0 and VZERO1 pins, dual output low power DACs
Resolution <sup>1</sup>		12			Bits	12-bit mode
		6			Bits	6-bit mode
Relative Accuracy <sup>1,10,11</sup>	INL	-6.5	±1	+3	LSB	12-bit mode, 1 LSB = $2.2\text{ V}/(2^{12} - 1)$
		-2.5	±0.1	+2	LSB	6-bit mode, 1 LSB = $2.2\text{ V}/2^6$
Differential Nonlinearity <sup>9</sup>	DNL	-0.99		+2.5	LSB	12-bit mode, guaranteed monotonic, 1 LSB = $2.2\text{ V}/(2^{12} - 1)$
		-0.5		+0.5	LSB	6-bit mode, guaranteed monotonic, 1 LSB = $2.2\text{ V}/2^6$
Offset Error <sup>1</sup>			±1	±7	mV	VBIASx/VZEROx in 12-bit mode, 2.5 V internal reference, DAC output code 0x000, target 0x000 code is 200 mV
		-1	±0.2	+1	mV	Differential offset voltage of VBIASx referred to VZEROx, LPDACDATx = 0x00000
Drift			±5		μV/°C	VBIASx or VZEROx referred to AGND, using internal low power reference
Differential Offset VBIASx to VZEROx $\approx 0\text{ V}$ <sup>1</sup>				4	μV/°C	Differential offset voltage of VBIASx referred to VZEROx, $T_A = -40^\circ\text{C}$ to $+60^\circ\text{C}$ , LPDACDATx = 0x1A680
Differential offset VBIASx to VZEROx $\approx \pm 600\text{ mV}$ <sup>1</sup>				10	μV/°C	Differential offset voltage of VBIAS referred to VZEROx, $T_A = -40^\circ\text{C}$ to $+60^\circ\text{C}$ , LPDACDATx = 0x1AAE0
Gain Error <sup>1</sup>			±0.2	±0.5	%	12-bit mode, DAC code = 0xFFFF with target voltage of 2.4 V, no correction for internal 2.5 V reference drift
Drift Mismatch			10		ppm/°C	Using internal low power reference
			±0.1		%	% of full scale on VBIAS0 to VBIAS1 in 12-bit mode
Analog Outputs						
Output Voltage Range <sup>1</sup>						LSB size is $2.2/(2^{12} - 1)$ , input common-mode voltage of low power potentiostat and low power TIA is $AVDD - 600\text{ mV}$
12-Bit Outputs		0.2		2.4	V	$AVDD \geq 2.8\text{ V}$
		0.2		2.3	V	$AVDD < 2.8\text{ V}$ , LPDACDATx, Bits[11:0] = 0xF40
						LSB size is $2.2/2^6$ , input common-mode voltage of low power potentiostat and low power TIA is $AVDD - 600\text{ mV}$
6-Bit Outputs		0.2		2.366	V	$AVDD \geq 2.8\text{ V}$
		0.2		2.3	V	$AVDD < 2.8\text{ V}$ , LPDACDATx, Bits[17:12] = 0x3D
AVDD to VBIASx and VZEROx Headroom Voltage <sup>1</sup>		400			mV	Minimum headroom between AVDD, VBIASx, and VZEROx output voltage, increases to 600 mV if connected to low power TIA or low power potentiostat amplifiers
Output Impedance <sup>1</sup>			1.65		MΩ	

Parameter	Symbol	Min	Typ	Max	Unit	Test Conditions/Comments
DAC AC Characteristics						
Output Settling Time			1.5		sec	Settled to $\pm 2$ LSB (12-bit) for $\frac{1}{4}$ of full scale to $\frac{3}{4}$ of full scale, with 1 k $\Omega$ load on amplifier output, 0.1 $\mu$ F capacitors connected to VBIASx and VZEROx pins, LPTIASWx, Bits[13:12] = 11
			500		$\mu$ S	Settled to $\pm 2$ LSB (12-bit) for $\frac{1}{4}$ of full scale to $\frac{3}{4}$ of full scale, with 1 k $\Omega$ load on amplifier output, capacitors on VBIASx and VZEROx disconnected, LPTIASWx, Bits[13:12] = 00
Glitch Energy			$\pm 5$		nV/sec	1 LSB change when the maximum number of bits changes simultaneously in the LPDACDATx register, switch to external capacitors on VBIASx and VZEROx opened, no capacitors on CEx/RCx_1 pins
EXCITATION DAC, PGA, AND RECONSTRUCTION FILTER (RCF) SPECIFICATIONS						
Use HSDACDAT range of 0x200 to 0xE00, specified for gain = 2, (HSDACCON, Bit 12 and HSDACCON, Bit 0 = 0) and gain = 0.05, (HSDACCON, Bit 12 and HSDACCON, Bit 0 = 1)						
DAC						
Common-Mode Voltage Range <sup>1</sup>		0.2		AVDD – 0.6	V	Set by excitation amplifiers N node (refer to the <a href="#">ADuCM355 Hardware Reference Manual</a> )
Resolution <sup>1</sup>		12			Bits	
Differential Nonlinearity <sup>9</sup>	DNL			+1/–0.99	LSB	Guaranteed monotonic, gain = 2
				$\pm 7$	LSB	Gain = 0.05
Relative Accuracy <sup>1,9</sup>	INL			$\pm 2$	LSB	Gain = 2
				$\pm 8$	LSB	Gain = 0.05
Full Scale <sup>12</sup>						
Positive			607		mV	Gain = 2, DAC code = 0xE00
			15.1		mV	Gain = 0.05, DAC code = 0xE00
Negative			–607		mV	Gain = 2, DAC code = 0x200
			–15.1		mV	Gain = 0.05, DAC code = 0x200
			1			
Gain Error Drift <sup>1</sup>						
Gain = 2			11.5		$\mu$ V/°C	
Gain = 0.05			0.33		$\mu$ V/°C	
Offset Error (Midscale)						Measured at an output of the excitation loop across RCALx, DAC code = 0x800, not calibrated in production, offset calibration can remove this error
			$\pm 25$		mV	Gain = 2
			$\pm 1$		mV	Gain = 0.05
Offset Error Drift <sup>1</sup>						
Gain = 2			40		$\mu$ V/°C	
Gain = 0.05			5		$\mu$ V/°C	
DC Power Supply Rejection Ratio	DC PSRR		70		dB	DC variation due to AVDD supply changes
PGA Programmable Gain		0.05		2		
RCF						
3 dB Corner Frequency Accuracy			$\pm 5$		%	Programmable to 50 kHz, 100 kHz, and 250 kHz
Allowed External Load Capacitance <sup>1</sup>						SEx, DEx, AINx, and RCALx pins
<80 kHz (Low Power Mode)				100	pF	
>80 kHz (High Power Mode)				80	pF	

Parameter	Symbol	Min	Typ	Max	Unit	Test Conditions/Comments
Overcurrent Limit Protection <sup>1</sup>			15		mA	Amplifier tires to limit source and sink current to this value via internal clamp
Allowed Duration of Overcurrent Limit <sup>1</sup>				5	sec	
Allowed Frequency of Overcurrent Conditions <sup>1</sup>				1	Per hour	
Short-Circuit Current			13		mA	
<b>SWITCH MATRIX SPECIFICATIONS</b>						
On Resistance (R <sub>ON</sub> ) <sup>1</sup>						Switches on AFE before ADC mux Characterized with a voltage sweep from 0 V to common-mode voltage (V <sub>CM</sub> ) production tested at 1.8 V
Current Carrying Switches			40	80	Ω	Tx switches, except T5 and T7
			30	52	Ω	Tx switches, T5 and T7 only
			35	70	Ω	D switches
Noncurrent Carrying Switches			1	5	kΩ	P and N switches
DC Off Leakage			370		pA	Analog input pin used for test driven to 0.2 V
DC On Leakage <sup>1</sup>			530	2000	pA	Analog input pin used for test driven to 0.2 V
<b>TEMPERATURE SENSORS</b>						
Resolution			0.3		°C	Channel 0 and Channel 1
Accuracy						Measurement taken immediately after exiting hibernate mode, user single point calibration required
			±2		°C	Temperature Sensor 0
			±3		°C	Temperature Sensor 1
<b>POWER-ON RESET (POR)</b>						
POR Trip Level <sup>13</sup>	POR	1.59	1.62	1.67	V	Refers to voltage on DVDD pin Power-on level
		1.799	1.8	1.801	V	Power-down level
POR Hysteresis <sup>1</sup>			10		mV	
Power-Up Timings <sup>1</sup>						
Delay Between POR Power-On and Power-Down Trip Levels		110			ms	After DVDD passes POR power-on trip level, DVDD must remain at or above power-down level for this period
Total Power Time for All Supplies				20	ms	All supplies must be above maximum POR trip, power-on trip level in this period
<b>EXTERNAL RESET</b>						
External Reset Minimum Pulse Width <sup>1</sup>		1			μs	Minimum pulse width required on external reset pin to trigger a reset sequence
<b>WATCHDOG TIMERS</b>						
Timeout Period <sup>1</sup>	WDT		32		sec	Timer on analog and digital die Default at power-up, analog die watchdog
<b>FLASH/EE MEMORY</b>						
Endurance		10,000			Cycles	Junction temperature (T <sub>J</sub> ) = 85°C
Data Retention		10			Years	
Size			128		kB	
<b>DIGITAL INPUTS</b>						
Input Leakage Current <sup>1</sup>						Voltage input high (V <sub>IH</sub> ) = DVDD, pull-up resistor disabled
Logic 1 GPIO			1	±5	nA	
Logic 0 GPIO			1	±10	nA	Voltage input low (V <sub>IL</sub> ) = 0 V, pull-up resistor disabled
Input Capacitance			10		pF	
Pin Capacitance						
XTALI			12		pF	
XTALO			12		pF	

Parameter	Symbol	Min	Typ	Max	Unit	Test Conditions/Comments
<b>LOGIC INPUTS</b>						
GPIO Input Voltage						
Low	$V_{INL}$			$0.25 \times DVDD$	V	
High	$V_{INH}$	$0.57 \times DVDD$			V	
Pull-Up Current <sup>1</sup>		30		130	$\mu A$	$V_{IN} = 0 V$ ; $DVDD = 3.6 V$
<b>LOGIC OUTPUTS</b>						
All digital outputs, excluding XTALO						
GPIO Output Voltage <sup>14</sup>						
High	$V_{OH}$	$DVDD - 0.4$			V	Source current ( $I_{SOURCE}$ ) = 2 mA in normal drive strength mode GPxDS, Bits[15:0] = 0x0000, $I_{SOURCE}$ = 4 mA in maximum drive strength mode GPxDS, Bits[15:0] = 0xFFFF
Low	$V_{OL}$			0.3	V	Sink current ( $I_{SINK}$ ) = 2 mA in normal drive strength mode (GPx, Bits[15:0] = 0x0000), $I_{SINK}$ = 4 mA in maximum drive strength mode (GPx, Bits[15:0] = 0xFFFF)
GPIO Short-Circuit Current			11.5		mA	
<b>OSCILLATORS</b>						
Digital Die Internal System Oscillator			26		MHz	
Accuracy			$\pm 1$	$\pm 3.2$	%	26 MHz output mode
System PLL			26		MHz	Main system clock
Analog Die Internal System Oscillator			16/32		MHz	
Accuracy for 16 MHz Mode			$\pm 0.5$	$\pm 2$	%	
Accuracy for 32 MHz Mode			$\pm 0.5$	$\pm 2$	%	
Switching Time <sup>1</sup>		4			$\mu s$	Time delay required after switching system clock source from 16 MHz or 32 MHz oscillator before accessing AFE die
External Crystal Oscillator			16	32	MHz	Can be selected in place of internal oscillator
Leakage			500	540	nA	XTALI and XTAO pins
Logic Inputs, XTALI Only						
Input Low Voltage ( $V_{INL}$ )			1.1		V	
Input High Voltage ( $V_{INH}$ )			1.7		V	
32 kHz Internal Oscillators			32.768		kHz	Used for watchdog timers and wake-up timers
Accuracy			$\pm 3$	$\pm 6$	%	Digital die low frequency oscillator
			$\pm 5$	$\pm 15$	%	Analog die low frequency oscillator
<b>START-UP TIME</b>						
At Power-On			85	120	ms	Processor clock = 16 MHz POR to first user code execution, DVDD and AVDD must be $\geq 2.8 V$ after this period
After Other Reset			50		ms	Reset to first user code execution, includes watchdog, external, and software resets
Digital Die Wake Up			10	30	$\mu s$	
Analog Die Wake Up <sup>1</sup>			50	190	$\mu s$	Wake-up time to allow communication with AFE die
ADC Wake Up <sup>1</sup>			90	135	$\mu s$	Time delay required on exiting hibernate or shutdown mode before starting ADC conversions if 1.8 V ADC reference capacitor voltage is maintained
<b>EXTERNAL INTERRUPTS</b>						
Pulse Width						
Level Triggered <sup>1</sup>		7			ns	
Edge Triggered <sup>1</sup>		1			ns	

Parameter	Symbol	Min	Typ	Max	Unit	Test Conditions/Comments
<b>POWER REQUIREMENTS<sup>15</sup></b>						
Power Supply Voltage Range AVDD to AGND, DVDD to DGND, DVDD_AD to DGND_AD		2.8	3.3	3.6	V	
Active Mode			4.75	5.2	mA	Default current after a reset, AFE and digital die in active mode
Flexi™ Mode			3.8	4.2	mA	Cortex-M3 disabled, DMA and other peripherals active
Hibernate Mode			3		μA	32 kHz oscillator active, 64 kB SRAM retained state supported on digital die
Shutdown Mode <sup>1</sup>			2		μA	Lowest power mode, only wake-up controller active
<b>Additional Power Supply Currents</b>						
ADC Circuits			1.5		mA	ADC update frequency ( $f_{ADC}$ )= 200 kSPS
			3.45		mA	$f_{ADC} = 400$ kSPS
HPTIA			0.3		mA	Low power mode
			0.9		mA	High power mode
High Speed DAC						Includes excitation buffer and instrumentation amplifier
			2.2		mA	Low power mode
			4.5		mA	High power mode
DFT Hardware Accelerator			550		μA	
Low Power Reference			1.65		μA	
Low Power DACs for VZEROx and VBIASx			2.3		μA	Per powered up DAC, excluding load current
Low Power Potentiostat and TIA Amplifier			2		μA	Per amplifier normal mode
			1		μA	Per amplifier half power mode
Standby Mode						Potentiostat amplifier and low power DACs enabled with both 32 kHz oscillators, 64 kB of SRAM state retained, all other peripherals in hibernate mode ( $T_A = -40^\circ\text{C}$ to $+60^\circ\text{C}$ )
			8.5	17.5	μA	Single sensor and potentiostat channel, $T_A = -40^\circ\text{C}$ to $+60^\circ\text{C}$
				40	μA	Single sensor and potentiostat channel, $T_A = -40^\circ\text{C}$ to $+60^\circ\text{C}$
			7	14	μA	Potentiostat amplifier and low power TIA 0 in half power mode, $T_A = -40^\circ\text{C}$ to $+60^\circ\text{C}$
				25	μA	Potentiostat amplifier and low power TIA 0 in half power mode, $T_A = -40^\circ\text{C}$ to $+60^\circ\text{C}$
			16		μA	Both potentiostat channels on
Arm Cortex-M3, Flash, and SRAM			30		μA/MHz	Dynamic current in active mode
DC Measurement Mode			6.4		mA	System clock 6.5 MHz, ADC, low power mode ( $T_A = -40^\circ\text{C}$ to $+60^\circ\text{C}$ )

Parameter	Symbol	Min	Typ	Max	Unit	Test Conditions/Comments
Impedance Spectroscopy Mode <sup>1</sup>			11.5		mA	When ac impedance engine (80 kHz) and ADC are active in low power mode, Arm processor also active with 26 MHz clock (T <sub>A</sub> = -40°C to +60°C)
				21		mA

<sup>1</sup> Guaranteed by design, but not production tested.

<sup>2</sup> If the ADC is calibrated to the recommended target of 1.835 V, the calculation for LSB size becomes (1.835 V/2<sup>15</sup>)/PGA gain.

<sup>3</sup> Code distribution can be reduced if the ADC output rate is reduced by using the sinc2 filter option.

<sup>4</sup> ADC offset and gain are not calibrated for high power mode during production. User calibration can eliminate this error.

<sup>5</sup> Noise can be reduced if the ADC output rate is reduced by using the sinc2 filter option.

<sup>6</sup> Measured using the box method.

<sup>7</sup> See Figure 10 for more details.

<sup>8</sup> The long-term stability specification is accelerated and noncumulative. The drift in subsequent 1000-hour periods is significantly lower than in the first 1000-hour period.

<sup>9</sup> See Figure 8 for more details.

<sup>10</sup> DAC linearity is calculated using a reduced code range of 0x10 (lower limit) to 0xF40 (upper limit).

<sup>11</sup> The average current from all GPIO pins must not exceed 20 mA per pin.

<sup>12</sup> High speed DAC offset calibration can remove this error. See the [ADuCM355 Hardware Reference Manual](#) for more details.

<sup>13</sup> It is recommended that the user enable power supply monitoring features to ensure operation, only when DVDD and AVDD are above 2.8 V.

<sup>14</sup> DAC gain error is calculated using a reduced code range of 100 to an internal 2.5 V voltage reference.

<sup>15</sup> Power figures exclude load currents from external circuits.

## RMS NOISE RESOLUTION OF ADC

The rms noise specifications for the ADC with different ADC digital filter settings are described in Table 2. The internal 1.82 V reference was used for all measurements. Table 3 shows the rms and peak-to-peak effective bits based on the noise results in Table 2 for various PGA gain settings. Peak-to-peak effective bits results are shown in parentheses. RMS bits are calculated as follows:

$$\log_2 \left( \frac{2 \times \text{Input Range}}{\text{RMS Noise}} \right)$$

Peak-to-peak bits are calculated as follows:

$$\log_2 \left( \frac{2 \times \text{Input Range}}{6.6 \times \text{RMS Noise}} \right)$$

**Table 2. ADC RMS Noise**

Update Rate (Hz)	Sinc3 Oversampling Rate (OSR)	Sinc2 OSR	RMS Noise (μV)				
			Gain = 1	Gain = 1.5	Gain = 2	Gain = 4	Gain = 9
200000	4	Not applicable	72.43	49.732	37.83	18.93	8.62
9090	4	22	29.29	19.59	10.4	6.687	4.42
900	5	178	24.0	17.11	12.832	6.416	1.018

**Table 3. ADC Effective Bits, Based on RMS Noise**

Update Rate (Hz)	Sinc3 OSR	Sinc2 OSR	Gain = 1	Gain = 1.5	Gain = 2	Gain = 4	Gain = 9	Settling Time (50 Hz and 60 Hz Filter Disabled)	Settling Time (50 Hz and 60 Hz Filter Enabled)
200000	4	Not applicable	14.6 (11.9 p-p)	15 (12.4 p-p)	14.95 (12.23 p-p)	14.95 (12.23 p-p)	14.9 (12.15 p-p)	16.25 μs	16.25 μs
9090	4	22	15 (13.18 p-p)	15 (13.8 p-p)	15 (14.09 p-p)	15 (13.73 p-p)	15 (13.15 p-p)	236.25 μs	236.25 μs
900	5	178	15 (13.47 p-p)	15 (13.96 p-p)	15 (13.8 p-p)	15 (13.79 p-p)	15 (15 p-p)	2.245 ms	37 ms

**TIMING SPECIFICATIONS**

In the timing specifications and timing diagrams,  $\overline{\text{CS}}$  refers to the SPI0\_ $\overline{\text{CS}}$  pin and the SPI1\_ $\overline{\text{CS}}$  pin, SCLK refers to the SPI0\_CLK pin and the SPI1\_CLK pin, MOSI refers to the SPI0\_MOSI pin and the SPI1\_MOSI pin, and MISO refers to the SPI0\_MISO pin and the SPI1\_MISO pin.

**Table 4. SPI Master Mode Timing (See Figure 3 and Figure 4)**

Parameter	Symbol	Min	Typ	Max	Unit	Test Conditions/Comments
TIMING REQUIREMENTS						
Chip Select ( $\overline{\text{CS}}$ ) to Serial Clock (SCLK) Edge	$t_{\overline{\text{CS}}}$	$0.5 \times \text{peripheral clock (PCLK)} - 3$			ns	Characterized with respect to double drive strength
SCLK Low Pulse Width	$t_{\text{SL}}$	$\text{PCLK} - 3.5$			ns	
SCLK High Pulse Width	$t_{\text{SH}}$	$\text{PCLK} - 3.5$			ns	
Data Input Setup Time Before SCLK Edge	$t_{\text{DSU}}$	5			ns	
Data Input Hold Time After SCLK Edge	$t_{\text{DHD}}$	20			ns	
SWITCHING CHARACTERISTICS						
Data Output Valid After SCLK Edge	$t_{\text{DAV}}$		25		ns	
Data Output Setup Before SCLK Edge	$t_{\text{DOSU}}$	$\text{PCLK} - 2.2$			ns	
$\overline{\text{CS}}$ High After SCLK Edge	$t_{\text{SFS}}$	$0.5 \times \text{PCLK} - 3$			ns	

**Table 5. SPI Slave Mode Timing (See Figure 5 and Figure 6)**

Parameter	Symbol	Min	Typ	Max	Unit	Test Conditions/Comments
TIMING REQUIREMENTS						
$\overline{\text{CS}}$ to SCLK Edge	$t_{\overline{\text{CS}}}$	38.5			ns	Characterized with respect to double drive strength
SCLK Low Pulse Width	$t_{\text{SL}}$	38.5			ns	
SCLK High Pulse Width	$t_{\text{SH}}$	38.5			ns	
Data Input Setup Time Before SCLK Edge	$t_{\text{DSU}}$	6			ns	
Data Input Hold Time After SCLK Edge	$t_{\text{DHD}}$	8			ns	
SWITCHING CHARACTERISTICS						
Data Output Valid After SCLK Edge	$t_{\text{DAV}}$	25			ns	
Data Output Valid After $\overline{\text{CS}}$ Edge	$t_{\text{DOCS}}$	38.5			ns	
$\overline{\text{CS}}$ High After SCLK Edge	$t_{\text{SFS}}$	38.5			ns	

Timing Diagrams

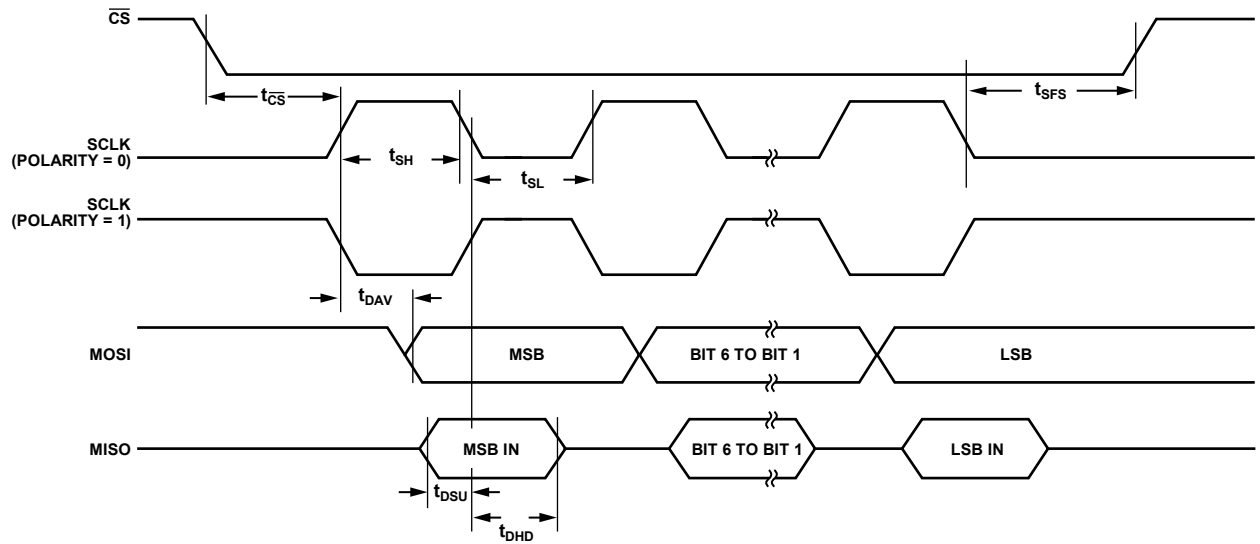

Figure 3. SPI Master Timing Diagram (Phase Mode = 1)

16674-003

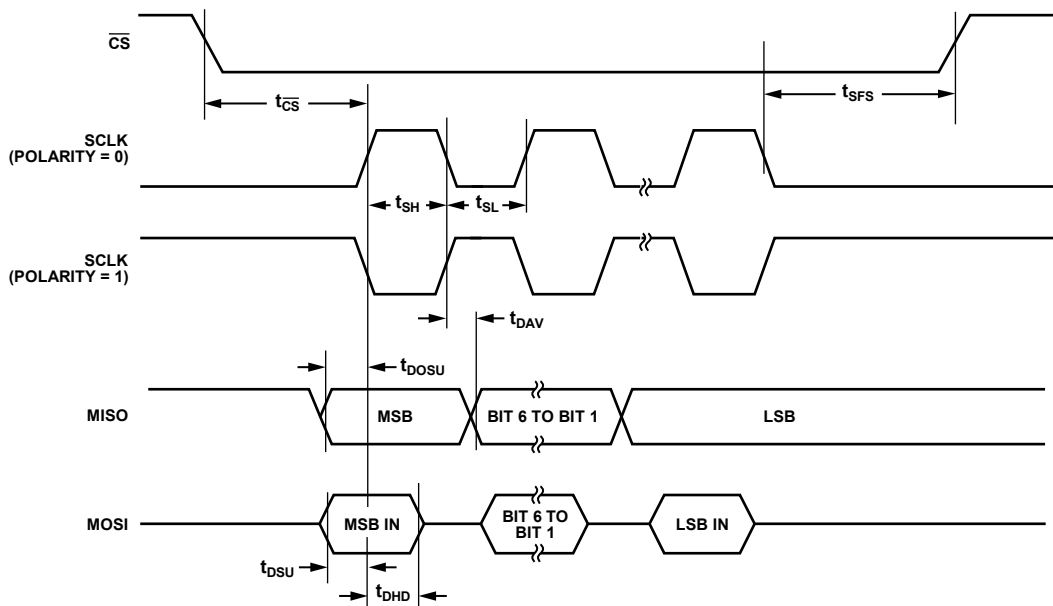

Figure 4. SPI Master Timing Diagram (Phase Mode = 0)

16674-004

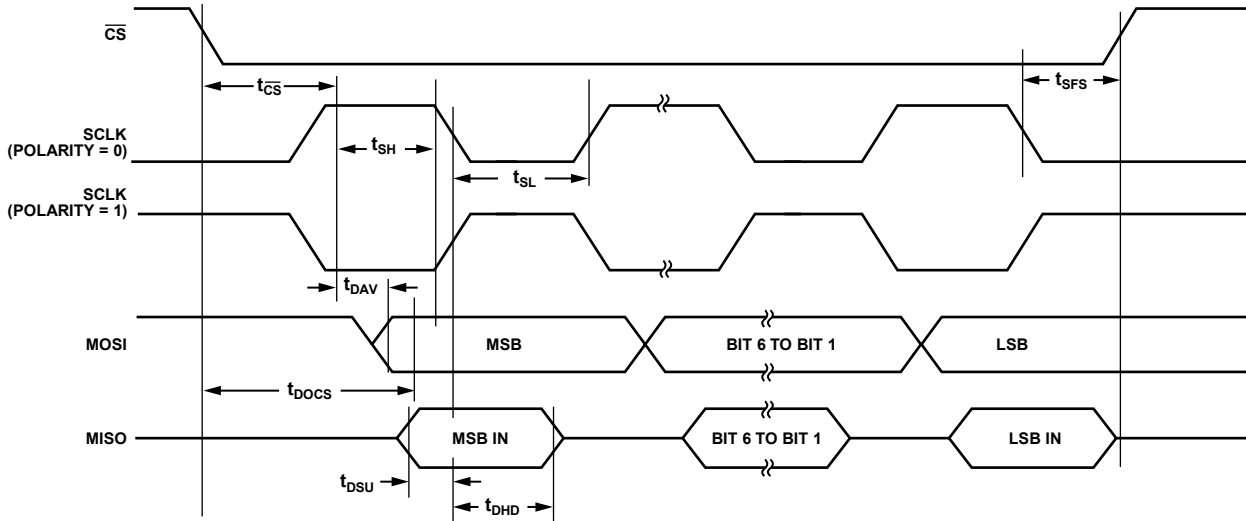

Figure 5. SPI Slave Timing Diagram (Phase Mode = 1)

16674-005

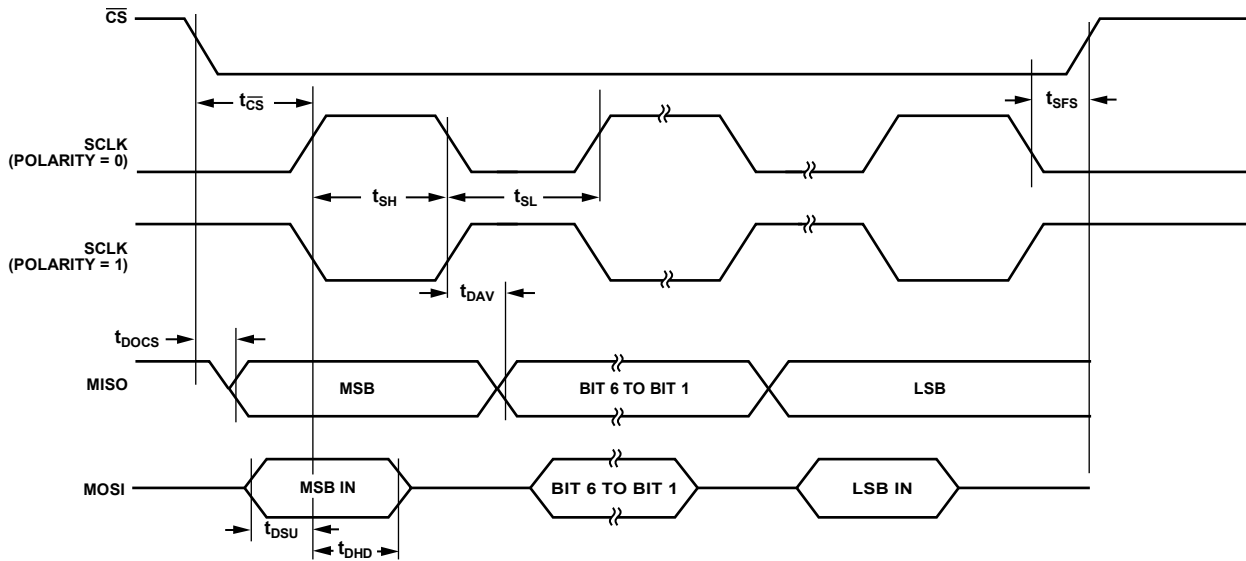

Figure 6. SPI Slave Timing Diagram (Phase Mode = 0)

16674-006

## ABSOLUTE MAXIMUM RATINGS

Table 6.

Parameter	Rating
AVDD to AGND	-0.3 V to +3.6 V
DVDD to DGND	-0.3 V to +3.6 V
AVDD to DVDD	DVDD $\pm$ 0.3 V
DVDD_AD to DGND_AD	-0.3 V to +3.6 V
Analog Input Voltage to AGND (AVDD Range is 2.8 V to 3.6 V)	-0.3 V to AVDD + 0.3 V, must be $\leq$ 3.6 V
Digital Input Voltage to DGND (DVDD Range is 2.8 V to 3.6 V)	-0.3 V to DVDD + 0.3 V, must be $\leq$ 3.6 V
Digital Output Voltage to DGND (DVDD Range is 2.8 V to 3.6 V)	-0.3 V to DVDD + 0.3 V, must be $\leq$ 3.6 V
AGND to DGND	-0.3 V to +0.3 V
DGND_AD to AGND	-0.3 V to +0.3 V
XTALI and XTALO	-0.3 V to DVDD_REG_ AD + 0.3 V
Total Positive GPIO Pins Current	0 mA to 30 mA
Total Negative GPIO Pins Current	-30 mA to 0 mA
Temperature Ranges	
Storage	-65°C to +150°C
Operating	-40°C to +85°C
Reflow Profiles	
SnPb Assemblies (10 sec to 30 sec)	240°C
Pb-Free Assemblies (20 sec to 40 sec)	260°C
Junction Temperature	150°C
Electrostatic Discharge (ESD)	
Human Body Model (HBM)	4 kV
Field-Induced Charged Device Model (FICDM)	1 kV

Stresses at or above those listed under Absolute Maximum Ratings may cause permanent damage to the product. This is a stress rating only; functional operation of the product at these or any other conditions above those indicated in the operational section of this specification is not implied. Operation beyond the maximum operating conditions for extended periods may affect product reliability.

## THERMAL RESISTANCE

Thermal performance is directly linked to printed circuit board (PCB) design and operating environment. Close attention to PCB thermal design is required.

$\theta_{JA}$  is the natural convection, junction to ambient thermal resistance measured in a one cubic foot sealed enclosure.  $\theta_{JC}$  is the junction to case thermal resistance.

Table 7. Thermal Resistance

Package Type <sup>1</sup>	$\theta_{JA}$	$\theta_{JC}$	Unit
CC-72-2	45	11	°C/W

<sup>1</sup> Test condition: thermal impedance simulated values are based on JEDEC 2S2P thermal test board with no bias. See JESD-51.

## ESD CAUTION



**ESD (electrostatic discharge) sensitive device.** Charged devices and circuit boards can discharge without detection. Although this product features patented or proprietary protection circuitry, damage may occur on devices subjected to high energy ESD. Therefore, proper ESD precautions should be taken to avoid performance degradation or loss of functionality.

### PIN CONFIGURATION AND FUNCTION DESCRIPTIONS

	1	2	3	4	5	6	7	8	9	10	11
A	RE0	DE0	SE0	AIN4_LPF0	VREF_1.82V	RCAL1	RCAL0	AIN7_LPF1	SE1	DE1	RE1
B	CE0	VZERO0	AIN6	AIN5	AGND_REF	AIN2	AIN3/ BUF_VREF1V8	AIN1	AIN0	VZERO1	CE1
C	CAP_POT0	VBIAS0								VBIAS1	CAP_POT1
D	RC0_0	RC0_1			BM/P1.1	P1.5/SPI1_CS	P1.3/SPI1_MOSI			RC1_1	RC1_0
E	AVDD_REG	VREF_2.5V			DNC		P1.2/SPI1_CLK			DNC	ADCVBIAS_CAP
F	DVDD_AD	DGND_AD			P1.0/SYS_WAKE	P1.4/SPI1_MISO	DGND			AGND	AVDD
G	DVDD_REG_AD	AVDD_DD								GPIO0/PWM0	VDCDC_CAP2P
H	XTALI	AGND_DD	SWCLK	SWDIO	P0.5/I2C_SDA	P0.3/SPI0_CS	P0.2/SPI0_MISO	P0.1/SPI0_MOSI	P0.0/SPI0_CLK	GPIO1/PWM1	VDCDC_CAP2N
J	XTALO	P0.11/ UART_SIN	P0.10/ UART_SOUT	P2.4	P0.4/I2C_SCL	DVDD	DVDD_REG	VDCDC_CAP1N	VDCDC_CAP1P	RESET	VDCDC_CAPOUT

DNC = DO NOT CONNECT.

Figure 7. Pin Configuration

Table 8. Pin Function Descriptions

Pin No.	Mnemonic	Type <sup>1</sup>	Description
J10	RESET	I	Reset Input (Active Low). An internal pull-up is included and enabled by default on this pin.
Digital I/O Pins			
H3	SWCLK	I	Serial Wire Debug Clock Input Pin. An internal pull-up resistor is enabled by default on this pin.
H4	SWDIO	I/O	Serial Wire Debug Data Input/Output Pin. An internal pull-up resistor is enabled by default on this pin.
H9	P0.0/SPI0_CLK	I/O	General-Purpose Input/Output Port 0.0 (P0.0)/SPI0 Clock (SPI0_CLK). This pin defaults as tristate.
H8	P0.1/SPI0_MOSI	I/O	General-Purpose Input/Output Port 0.1 (P0.1)/SPI0 Data Master Output, Slave Input (SPI0_MOSI). This pin defaults as tristate.
H7	P0.2/SPI0_MISO	I/O	General-Purpose Input/Output Port 0.2 (P0.2)/SPI0 Data Master Input, Slave Output (SPI0_MISO). This pin defaults as tristate.
H6	P0.3/SPI0_CS	I/O	General-Purpose Input/Output Port 0.3 (P0.3)/SPI0 Chip Select (SPI0_CS). This pin is an input for slave mode or an output for master mode. This pin defaults as tristate.
J5	P0.4/I2C_SCL	I/O	General-Purpose Input/Output Port 0.4 (P0.4)/I <sup>2</sup> C Interface Clock for I <sup>2</sup> C (I2C_SCL). This pin defaults as tristate.
H5	P0.5/I2C_SDA	I/O	General-Purpose Input/Output Port 0.5 (P0.5)/ I <sup>2</sup> C Interface Data for I <sup>2</sup> C (I2C_SDA). This pin defaults as tristate.

Pin No.	Mnemonic	Type <sup>1</sup>	Description
J3	P0.10/UART_SOUT	I/O	General-Purpose Input/Output Port 0.10 (P0.10)/UART Output (UART_SOUT). This pin defaults as tristate.
J2	P0.11/UART_SIN	I/O	General-Purpose Input/Output Port 0.11 (P0.11)/UART Input (UART_SIN). This pin defaults as tristate.
F5	P1.0/SYS_WAKE	I/O	General-Purpose Input/Output Port 1.0 (P1.0)/External Interrupt Signal (SYS_WAKE). This pin is capable of waking the device from hibernate or shutdown modes. This pin defaults as tristate.
D5	BM/P1.1	I/O	Boot Mode (BM)/General-Purpose Input/Output Port 1.1 (P1.1). When this pin is low during and for a short time after any reset, the device enters an infinite loop before executing user code, which allows the user flash memory to be erased via the serial wire debug interface if erroneous user code is programmed to the flash.
E7	P1.2/SPI1_CLK	I/O	General-Purpose Input/Output Port 1.2 (P1.2)/SPI1 Clock (SPI1_CLK). This pin defaults as tristate.
D7	P1.3/SPI1_MOSI	I/O	General-Purpose Input/Output Port 1.3 (P1.3)/SPI1 Data Master Output, Slave Input (SPI1_MOSI). This pin defaults as tristate.
F6	P1.4/SPI1_MISO	I/O	General-Purpose Input/Output Port 1.4 (P1.4)/SPI1 Master Input, Slave Output (SPI1_MISO). This pin defaults as tristate.
D6	P1.5/SPI1_C $\bar{S}$	I/O	General-Purpose Input/Output Port 1.5 (P1.5)/SPI1 Chip Select (SPI1_C $\bar{S}$ ). This pin defaults as tristate.
J4	P2.4	I/O	General-Purpose Input/Output Port 2.4. This pin defaults as tristate.
G10	GPIO0/PWM0	I/O	General-Purpose Input/Output Port (GPIO0)/PWM Output (PWM0). This pin features a POR output and analog die power mode status. After a POR, this pin is pulled low for 32 ms after the POR sequence is completed. After this period and after all other reset types, this pin defaults to an output driven high.
H10	GPIO1/PWM1	I/O	General-Purpose Input/Output Port (GPIO1)/PWM Output (PWM1). This pin features an optional external 16 MHz clock input. This pin defaults as tristate.
Sensor Channel 0 Pins			
B1	CE0	AI/O	Output of Potentiostat 0 Amplifier. This pin is connected to a counter electrode when measuring electrochemical sensors. Optionally, this pin can be used as an ADC input. If unused, it is recommended to connect this pin to AVDD_REG or AGND.
A1	RE0	AI	Input to Analog Input Switch Matrix. For electrochemical sensor measurement, connect this pin to Potentiostat 0 amplifier, inverting input. Optionally, this pin can be used as an ADC input. If unused, it is recommended to connect this pin to AVDD_REG or AGND.
A3	SE0	AI	Input to Analog Switch Matrix. For electrochemical sensor measurement, connect this pin to TIA, inverting input. If unused, it is recommended to connect this pin to AVDD_REG or AGND.
A2	DE0	AI	Diagnostic Electrode Input 0. This pin is internally connected to the analog input switch matrix. If unused, it is recommended to connect this pin to AVDD_REG or AGND.
C2	VBIAS0	AI/O	VBIAS0 to DAC0 Output. This pin is used internally to set the common-mode voltage of the Potentiostat 0 amplifier. Connect this pin to AGND via a 100 nF capacitor. Optionally, this pin can be used as an ADC input. If unused, it is recommended to connect this pin to AVDD_REG or AGND. Do not use this pin as a voltage source for an external circuit.
B2	VZERO0	AI/O	VZERO0 to DAC0 Output. This pin is used internally to set the common-mode voltage of TIA0. Optionally, this pin can be used as an ADC input. If unused, it is recommended to connect this pin to AVDD_REG or AGND. Do not use this pin as a voltage source for an external circuit.
D1	RC0_0	AI	Connection to External Capacitor for Low Power TIA Input. Connect the other side of the capacitor to RC0_1. Use a 100 nF capacitor with this pin. Optionally, a TIA gain resistor can be connected across RC0_0 and RC0_1.
D2	RC0_1	AI	Connection to External Capacitor for Low Power TIA Input. Connect the other side of the capacitor to RC0_0. Use a 100 nF capacitor with this pin. Optionally, a TIA gain resistor can be connected across RC0_0 and RC0_1.
C1	CAP_POT0	AI	High Frequency Filter Capacitor. Connect this pin to CE0 pin via an external capacitor of 100 nF. Used for resistor/capacitive (RC) filter on RE0 input.

Pin No.	Mnemonic	Type <sup>1</sup>	Description
Sensor Channel 1 Pins			
B11	CE1	AI/O	Output of Potentiostat 1 Amplifier. This pin is connected to a counter electrode when measuring electrochemical sensors. Optionally, this pin can be used as an ADC input. If unused, it is recommended to connect this pin to AVDD_REG or AGND.
A11	RE1	AI	Input to Analog Input Switch Matrix. For electrochemical sensor measurement, connect this pin to the Potentiostat 1 amplifier inverting input. Optionally, this pin can be used as an ADC input. If unused, it is recommended to connect this pin to AVDD_REG or AGND.
A9	SE1	AI	Input to Analog Switch Matrix. For electrochemical sensor measurement, connect this pin to TIA, inverting input. If unused, it is recommended to connect this pin to AVDD_REG or AGND.
A10	DE1	AI	Diagnostic Electrode Input 1. This pin is internally connected to the analog input switch matrix. If unused, it is recommended to connect this pin to AVDD_REG or AGND.
C10	VBIAS1	AI/O	VBIAS1 to DAC1 Output. This pin is used internally to set the common-mode voltage of the Potentiostat 1 amplifier. Connect this pin to AGND via a 100 nF capacitor. Optionally, this pin can be used as an ADC input. If unused, it is recommended to connect this pin to AVDD_REG or AGND. Do not use this pin as a voltage source for an external circuit.
B10	VZERO1	AI/O	VZERO1 to DAC1 Output. This pin is used internally to set the common-mode voltage of TIA1. Optionally, this pin can be used as an ADC input. If unused, it is recommended to connect this pin to AVDD_REG or AGND. Do not use this pin as a voltage source for an external circuit.
D11	RC1_0	AI	Connection to External Capacitor for Low Power TIA Input. Connect this pin to the other side of the capacitor to RC1_1. Use a 100 nF capacitor with this pin. Optionally, a TIA gain resistor can be connected across RC1_0 and RC1_1.
D10	RC1_1	AI	Connection to External Capacitor for Low Power TIA Input. Connect this pin to the other side of the capacitor to RC1_0. Use a 100 nF capacitor with this pin. Optionally, a TIA gain resistor can be connected across RC1_0 and RC1_1.
C11	CAP_POT1	AI	High Frequency Filter Capacitor. Connect this pin to CE1 pin via an external capacitor of 100 nF. This pin is used for the RC filter on the RE1 input.
Other Analog Pins			
A7	RCAL0	AI	Calibration Resistor Connection. This pin is connected to the excitation amplifier output. This pin is used for the calibration of impedance measurement circuitry.
A6	RCAL1	AI	Calibration Resistor Connection. This pin is connected to the high power TIAs, inverting input. This pin is used for the calibration of impedance measurement circuitry.
B9	AIN0	AI	ADC Input.
B8	AIN1	AI	ADC Input.
B6	AIN2	AI	ADC Input.
B7	AIN3/BUF_VREF1V8	AI/O	ADC Input (AIN3)/Buffered 1.8 V Bias (BUF_VREF1V8). The maximum load = 200 $\mu$ A. Connect BUF_VREF1V8 to AGND via a 100 pF capacitor.
A4	AIN4_LPF0	AI/O	External Low-Pass Filter. This pin is required for TIA0 when measuring electrochemical sensors. A 4.7 $\mu$ F capacitor is recommended when this pin is used as the low-pass filter capacitor connection. Optionally, this pin can be used as an ADC input.
B4	AIN5	AI	ADC Input.
B3	AIN6	AI	ADC Input.
A8	AIN7_LPF1	AI/O	External Low-Pass Filter. This pin is required for TIA1 when measuring electrochemical sensors. A 4.7 $\mu$ F capacitor is recommended when this pin is used as the low-pass filter capacitor connection. Optionally, this pin can be used as an ADC input.
A5	VREF_1.82V	AI/O	Decoupling Capacitor Connection for 1.8 V Internal Reference. Connect a 4.7 $\mu$ F capacitor between this pin and AGND. Do not use this pin as a voltage source for an external circuit.
E2	VREF_2.5V	AI/O	Decoupling Capacitor Connection for 2.5 V Internal Reference. Connect a 470 nF capacitor between this pin and AGND. Do not use this pin as a voltage source for an external circuit.
E11	ADCVBIAS_CAP	AI/O	Decoupling Capacitor for PGA Common Mode Reference. Connect a 470 nF capacitor between this pin and AGND. Do not use this pin as a voltage source for an external circuit.
B5	AGND_REF	S	Reference Ground Pin. Connect this pin to AGND.

Pin No.	Mnemonic	Type <sup>1</sup>	Description
<b>Power Pins</b>			
G2	AVDD_DD	S	Supply Pin for Digital Die. Do not connect this pin directly to AVDD. Connect this pin to Pin J6 and Pin F1. See the Recommended Circuit and Component Values section for more details. This pin supplies the digital die 26 MHz and 32 kHz oscillators and is the digital die POR.
H2	AGND_DD	S	Ground Pin for Digital Die.
F1	DVDD_AD	S	Digital Supply for Analog Die. Connect this pin to Pin J6 and Pin G2. See the Recommended Circuit and Component Values section for more details. This pin supplies the AFE die POR, 32 kHz oscillator, and watchdog timer. This pin is the supply for the low dropout (LDO) regulator that generates DVDD_REG_AD.
F2	DGND_AD	S	Digital Ground for Analog Die.
J6	DVDD	S	Digital Supply Pin. Do not connect this pin directly to AVDD. Connect this pin to Pin F1 and Pin G2. See the Recommended Circuit and Component Values section for more details. This pin is the main digital supply pin, including flash and SRAM. This pin is the supply for the LDO regulator that generates DVDD_REG (1.2 V).
F7	DGND	S	Digital Ground Pin for Entire Chip.
F11	AVDD	S	Analog Supply Pin. This pin is the main analog supply for the AFE die. This pin supplies the ADC input circuits, DACs, and amplifier circuits. This pin is the supply for the LDO regulator AVDD_REG (1.8 V).
F10	AGND	S	Analog Ground Pin.
J7	DVDD_REG	S	Output of 1.2 V On-Chip LDO Regulator. Connect a 470 nF capacitor between this pin and DGND. This pin supplies the Arm Cortex-M3 core, flash, SRAM, and core digital circuits of the digital die.
E1	AVDD_REG	S	Output of 1.8 V On-Chip LDO Regulator. Connect a 470 nF capacitor between this pin and AGND. This pin supplies the AFE die ADC and DAC core circuits, 16 MHz oscillator, and temperature sensors.
G1	DVDD_REG_AD	S	Output of 1.8 V On-Chip LDO Regulator. Connect a 470 nF capacitor between this pin and DGND. This pin supplies the 1.8 V regulated voltage (digital) on the AFE die. This pin powers ADC postprocessing circuits and waveform generator.
J8	VDCDC_CAP1N	S	Buck Fly Capacitor Connection to VDCDC_CAP1P (100 nF). Leave this pin unconnected if the buck convertor is disabled.
J9	VDCDC_CAP1P	S	Buck Fly Capacitor Connection to VDCDC_CAP1N (100 nF). Leave this pin unconnected if the buck convertor is disabled.
H11	VDCDC_CAP2N	S	Buck Fly Capacitor Connection to VDCDC_CAP2P (100 nF). Leave this pin unconnected if the buck convertor is disabled.
G11	VDCDC_CAP2P	S	Buck Fly Capacitor Connection to VDCDC_CAP2N (100 nF). Leave this pin unconnected if the buck convertor is disabled.
J11	VDCDC_CAPOUT	S	Decoupling Capacitor for DC-to-DC Output. The recommended value on this pin is 470 nF. Leave this pin unconnected if the buck convertor is disabled.
<b>XTAL and Do Not Connect (DNC) Pins</b>			
H1	XTALI	AI	External 16 MHz Crystal Oscillator Input for Analog Die. Optionally, connect this pin to DGND_AD if not using an external crystal. Ensure that this pin is not connected to a voltage level above 1.8 V.
J1	XTALO	AO	External 16 MHz Crystal Oscillator Output for Analog Die. Optionally, leave this pin unconnected if not using an external crystal.
E5	DNC		Do not connect.
E10	DNC		Do not connect.

<sup>1</sup> I is input, I/O is input/output, AI/O is analog input/output, AI is analog input, S is supply, and AO is analog output.

TYPICAL PERFORMANCE CHARACTERISTICS

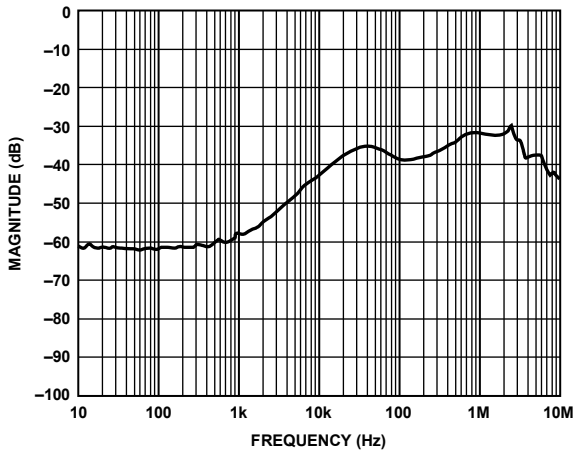

Figure 8. ADC 1.82 V Voltage Reference, AC PSRR

16674-008

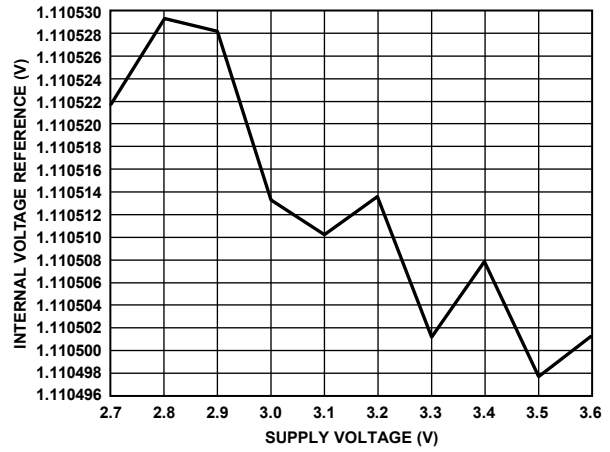

Figure 11. Internal 1.11 V Voltage Reference, DC PSRR

16674-011

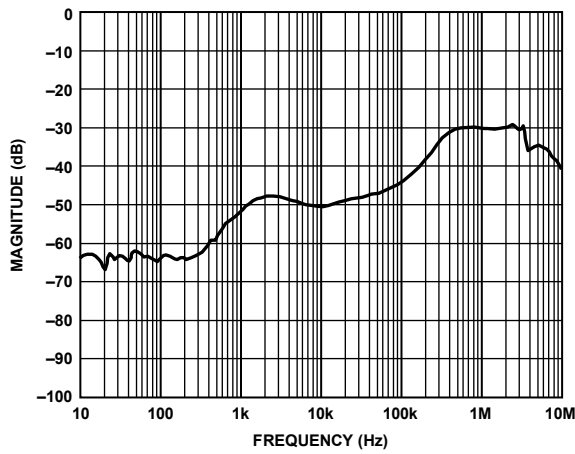

Figure 9. Low Power 2.5 V Voltage Reference, AC PSRR

16674-009

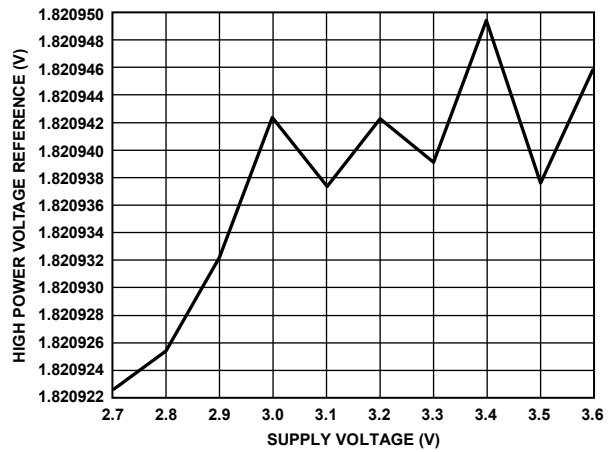

Figure 12. ADC 1.82 V Voltage Reference, DC PSRR

16674-012

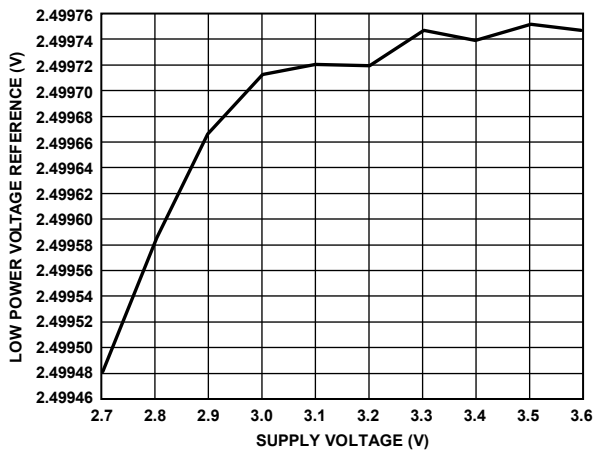

Figure 10. Low Power 2.5 V Voltage Reference, DC PSRR

16674-010

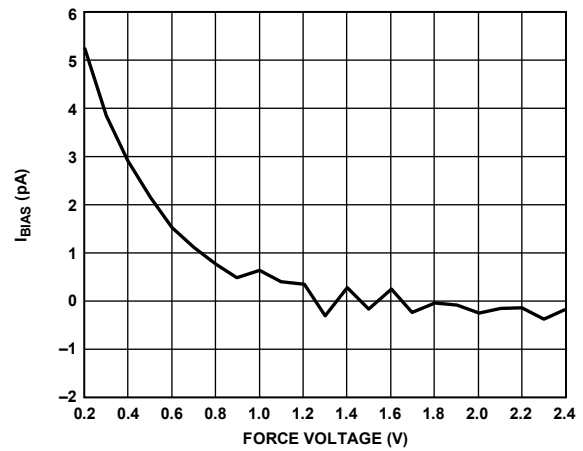

Figure 13. Input Bias Current ( $I_{BIAS}$ ) via Reference Electrode Pin of Low Power TIAs for Varying Voltage on Reference Electrode Pin,  $T_A = 25^\circ\text{C}$

16674-013

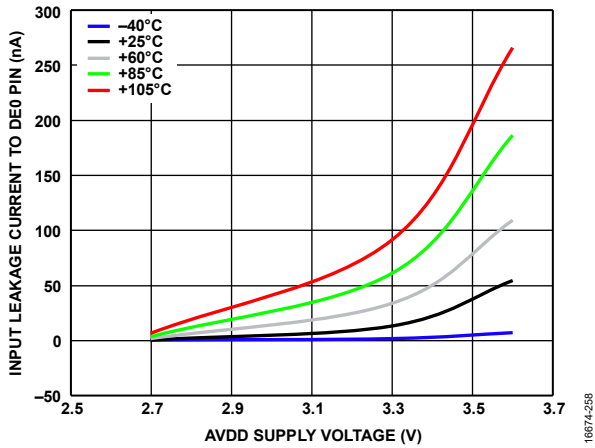

Figure 14. Input Leakage Current to DE0 Pin vs. AVDD Supply Voltage, Various Temperatures

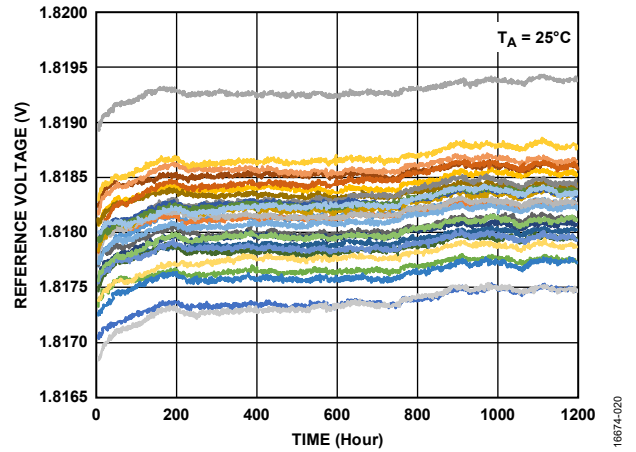

Figure 16. High Power 1.82 V Voltage Reference Drift over 1200 Hours at  $T_A = 25^\circ\text{C}$

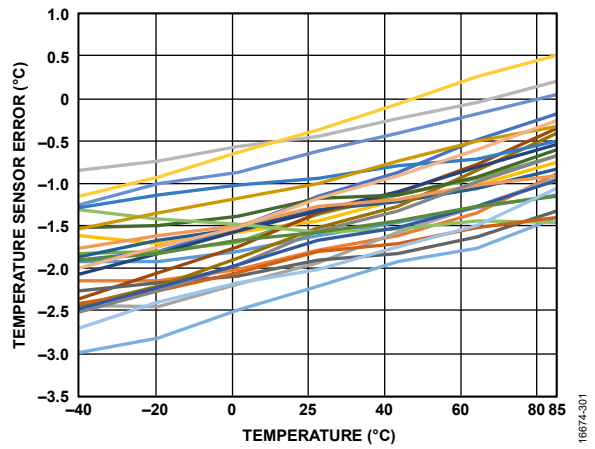

Figure 15. Typical Internal Temperature Sensor 0 Channel Performance for 26 Devices

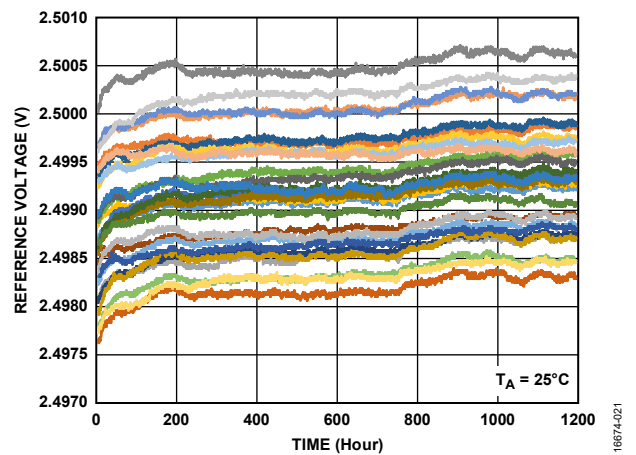

Figure 17. Low Power 2.5 V Voltage Reference Drift over 1200 Hours at  $T_A = 25^\circ\text{C}$

## APPLICATIONS INFORMATION

### RECOMMENDED CIRCUIT AND COMPONENT VALUES

The recommended external components required by the ADuCM355 are shown in Figure 19.

There are two digital supply pins, DVDD\_AD and DVDD. Decouple these pins with a 0.1  $\mu\text{F}$  capacitor placed as close as possible to each of the two pins and a 4.7  $\mu\text{F}$  capacitor at the supply source. Similarly, the analog supply pins, AVDD and AVDD\_DD, each require a 0.1  $\mu\text{F}$  capacitor placed as close as possible to each pin with a 4.7  $\mu\text{F}$  capacitor at the supply source.

The ADuCM355 contains three internal regulators. These regulators each require external decoupling capacitors. The pin names for the digital regulators are DVDD\_REG and DVDD\_REG\_AD. Each pin requires a 0.47  $\mu\text{F}$  capacitor to DGND. The AVDD\_REG analog regulator requires a 0.47  $\mu\text{F}$  decoupling capacitor to AGND if separate ground planes are used.

The ADuCM355 has an optional dc-to-dc convertor (buck convertor) on the digital die that can save power if enabled. When unused, the VDCDC\_CAP1N, VDCDC\_CAP1P, VDCDC\_CAP2N, VDCDC\_CAP2P, and VDCDC\_CAPOUT pins can be left disconnected. If the dc-to-dc converter is used, a 100 nF capacitor must be connected between VDCDC\_CAP1N and VDCDC\_CAP1P and between VDCDC\_CAP2N and VDCDC\_CAP2P. The VDCDC\_CAPOUT pin requires a 0.47  $\mu\text{F}$  capacitor to the digital ground when the dc-to-dc converter is enabled.

There are three internal references requiring external capacitors for stability. Connect the ADCVBIAS\_CAP and VREF\_2.5V pins

to AGND via 0.47  $\mu\text{F}$  capacitors. Connect a 4.7  $\mu\text{F}$  capacitor between the VREF\_1.8V pin and AGND.

For calibration purposes, an external precision resistor is recommended between the RCAL0 and RCAL1 pins. Typically, this is a 200  $\Omega$  resistor, but it can have a different value. A low ppm temperature coefficient ( $\leq 10$  ppm/ $^{\circ}\text{C}$ ) and 0.1% or better accuracy allow the most accurate system calibration.

Figure 19 shows connections between the ADuCM355 and an external 3-lead, electrochemical gas sensor. For electromagnetic compatibility (EMC) purposes, (radiated immunity), a capacitor connected to AGND is recommended for each sensor pin.

Typically, a value between 22 pF and 30 pF is recommended. Use a 100 nF capacitor between the CEx pin of the sensor and the ADuCM355 CAP\_POT0 pin. Similarly, if the ADuCM355 Channel 1 potentiostat is used, a 100 nF capacitor between the CEx pin of the sensor and the ADuCM355 CAP\_POT1 pin is recommended. The output of each of the low power TIAs has a programmable low-pass filter. The resistor is internal and is programmable, and the capacitor for each low-pass filter is external. The capacitor connects between the AIN4\_LPF0 pin and the AGND pin for TIA0, and between the AIN7\_LPF1 pin and the AGND pin for TIA1. The low power TIAs require a 100 nF capacitor between their inverting input and output terminals for stability purposes. For low power TIA 0, the capacitor connects between the RC0\_0 pin and RC0\_1 pin. If the low power TIA 1 channel is used, connect the capacitor between the RC1\_0 pin and RC1\_1 pin.

If the low power DACs are used, each output (VBIAS0, VZERO0, VBIAS1, and VZERO1) requires a 100 nF capacitor to AGND.

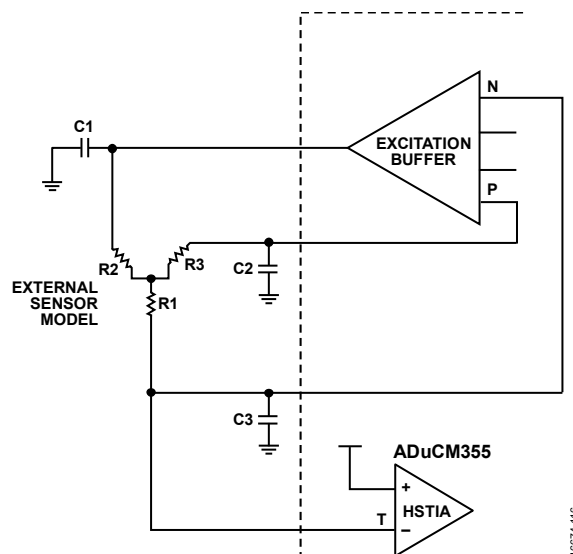

Figure 18. High Speed Loop Connected to an External Sensor (R1 to R3), C1 to C3 Represents Total External Capacitance

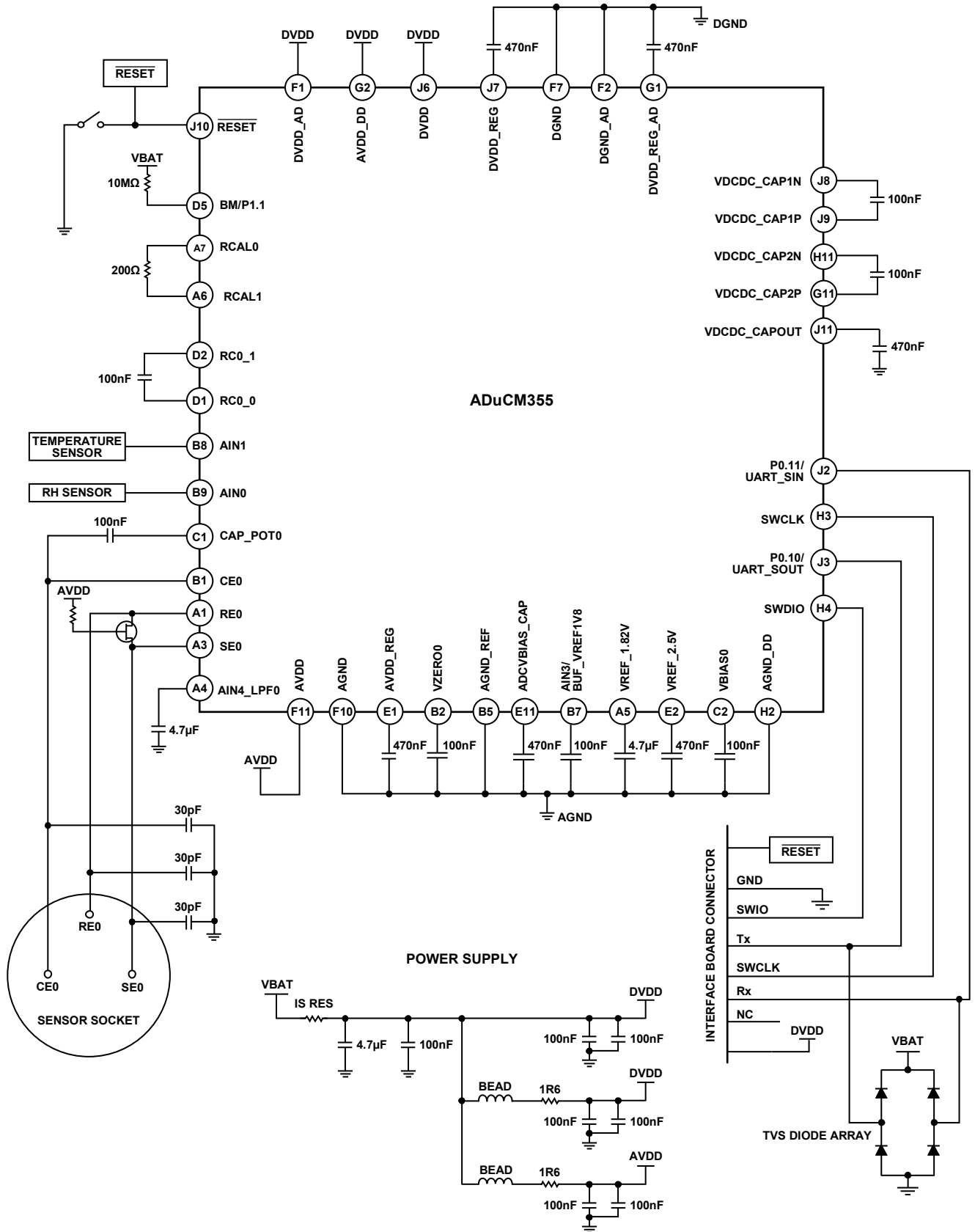

Figure 19. Recommended External Components

OUTLINE DIMENSIONS

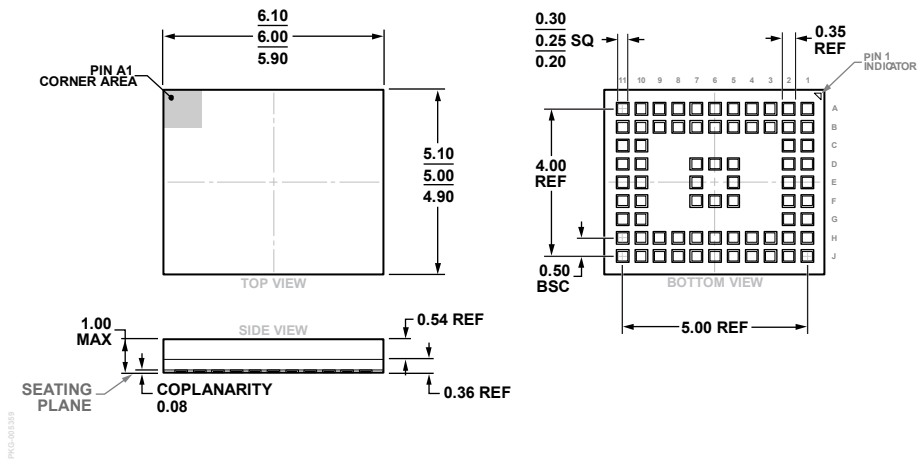

Figure 20. 72-Terminal Land Grid Array [LGA] (CC-72-2)  
Dimensions shown in millimeters

ORDERING GUIDE

Model <sup>1</sup>	Temperature Range	Package Description	Package Option
ADuCM355BCCZ	-40°C to +85°C	72-Terminal Land Grid Array [LGA]	CC-72-2
ADuCM355BCCZ-RL7	-40°C to +85°C	72-Terminal Land Grid Array [LGA]	CC-72-2
EVAL-ADuCM355QSPZ		Evaluation Board and Quick Start Development System	

<sup>1</sup> Z = RoHS Compliant Part.

I<sup>2</sup>C refers to a communications protocol originally developed by Philips Semiconductors (now NXP Semiconductors).

## Looking for pricing, stock, or lifecycle information?

Click below to explore more details on WIN SOURCE:

 [View ADUCM355BCCZ-RL7 on WIN SOURCE](#)

 [Analog Devices Inc. Information](#)

## Optimize Your Supply Chain with WIN SOURCE Solutions

-  Global Sourcing Solution
-  Obsolete Management
-  Cost Control Management
-  Shortage Management
-  Alternative Solution
-  Excess Inventory Management