



**THE DATASHEET OF
R7FA4W1AD2CNG#AA0**



Renesas RA4W1 Group

Datasheet

32-Bit MCU

Renesas Advanced (RA) Family
Renesas RA4 Series

All information contained in these materials, including products and product specifications, represents information on the product at the time of publication and is subject to change by Renesas Electronics Corp. without notice. Please review the latest information published by Renesas Electronics Corp. through various means, including the Renesas Electronics Corp. website (<http://www.renesas.com>).

High efficiency 48-MHz Arm® Cortex®-M4 core, 512-KB code flash memory, 96-KB SRAM, Segment LCD Controller, Capacitive Touch Sensing Unit, Bluetooth Low Energy, USB 2.0 Full-Speed, 14-Bit A/D Converter, 12-Bit D/A Converter, security and safety features.

Features

■ Arm Cortex-M4 Core with Floating Point Unit (FPU)

- Armv7E-M architecture with DSP instruction set
- Maximum operating frequency: 48 MHz
- Support for 4-GB address space
- Arm Memory Protection Unit (Arm MPU) with 8 regions
- Debug and Trace: ITM, DWT, FPB, TPIU, and ETB
- CoreSight™ debug port: JTAG-DP and SW-DP

■ Memory

- 512-KB code flash memory
- 8-KB data flash memory (100,000 erase/write cycles)
- 96-KB SRAM
- Flash Cache (FCACHE)
- Memory Protection Units
- Memory Mirror Function (MMF)
- 128-bit unique ID

■ Connectivity

- Bluetooth Low Energy
 - Bluetooth 5.0 core specification compliant BLE transceiver and link layer
 - Supporting LE 1M, 2M and Coded PHY, and LE Advertising extension
 - Dedicated AES-CCM (128-bit blocks) encryption circuit
- USB 2.0 Full-Speed (USBFS) module
 - On-chip transceiver
 - Compliant with USB Battery Charging Specification 1.2
- Serial Communications Interface (SCI) × 4
 - UART
 - Simple IIC
 - Simple SPI
- Serial Peripheral Interface (SPI) × 2
- I²C bus interface (IIC) × 2
- Controller Area Network (CAN) module

■ Analog

- 14-bit A/D Converter (ADC14)
- 12-bit D/A Converter (DAC12)
- 8-bit D/A Converter (DAC8) × 2 (for ACMLP)
- Low Power Analog Comparator (ACMLP) × 2
- Operational Amplifier (OPAMP) × 1
- Temperature Sensor (TSN)

■ Timers

- General PWM Timer 32-bit (GPT32) × 4
- General PWM Timer 16-bit (GPT16) × 3
- Asynchronous General-Purpose Timer (AGT) × 2
- Watchdog Timer (WDT)

■ Safety

- Error Correction Code (ECC) in SRAM
- SRAM parity error check
- Flash area protection
- ADC self-diagnosis function
- Clock Frequency Accuracy Measurement Circuit (CAC)
- Cyclic Redundancy Check (CRC) calculator
- Data Operation Circuit (DOC)
- Port Output Enable for GPT (POEG)
- Independent Watchdog Timer (IWDT)
- GPIO readback level detection
- Register write protection
- Main oscillator stop detection
- Illegal memory access

■ System and Power Management

- Low power modes
- Realtime Clock (RTC) with calendar and Battery Backup support
- Event Link Controller (ELC)
- DMA Controller (DMAC) × 4
- Data Transfer Controller (DTC)
- Key Interrupt Function (KINT)
- Power-on reset
- Low Voltage Detection (LVD) with voltage settings

■ Security and Encryption

- AES128/256
- GHASH
- True Random Number Generator (TRNG)

■ Human Machine Interface (HMI)

- Segment LCD Controller (SLCDC)
 - Up to 9 segments × 4 commons
 - Capacitive Touch Sensing Unit (CTSU)

■ Multiple Clock Sources

- Main clock oscillator (MOSC)
 - (1 to 20 MHz when VCC = 2.4 to 3.6 V)
 - (1 to 8 MHz when VCC = 1.8 to 2.4 V)
- Sub-clock oscillator (SOSC) (32.768 kHz)
- High-speed on-chip oscillator (HOCO)
 - (24, 32, 48, 64 MHz when VCC = 2.4 to 3.6 V)
 - (24, 32, 48 MHz when VCC = 1.8 to 3.6 V)
- Middle-speed on-chip oscillator (MOCO) (8 MHz)
- Low-speed on-chip oscillator (LOCO) (32.768 kHz)
- IWDT-dedicated on-chip oscillator (15 kHz)
- Clock trim function for HOCO/MOCO/LOCO
- Clock out support

■ General Purpose I/O Ports

- Up to 35 input/output pins
 - Up to 3 CMOS input
 - Up to 32 CMOS input/output
 - Up to 4 input/output 5 V tolerant
 - Up to 1 high current (20 mA)

■ Operating Voltage

- VCC: 1.8 to 3.6 V

■ Operating Temperature and Packages

- Ta = -40°C to +85°C
 - 56-pin QFN (7 mm × 7 mm, 0.4 mm pitch)

1. Overview

The MCU integrates multiple series of software- and pin-compatible Arm®-based 32-bit cores that share a common set of Renesas peripherals to facilitate design scalability and efficient platform-based product development.

The MCU in this series incorporates a low-power and high-performance Arm Cortex®-M4 32-bit core running up to 48 MHz, with the following features:

- 512-KB code flash memory
- 96-KB SRAM
- Bluetooth Low Energy (BLE)
- Segment LCD Controller (SLCDC)
- Capacitive Touch Sensing Unit (CTSU)
- USB 2.0 Full-Speed Module (USBFS)
- 14-bit A/D Converter (ADC14)
- 12-bit D/A Converter (DAC12)
- Security features.

1.1 Function Outline

Table 1.1 Arm core

Feature	Functional description
Arm Cortex-M4 core	<ul style="list-style-type: none"> • Maximum operating frequency: up to 48 MHz • Arm Cortex-M4 core: <ul style="list-style-type: none"> - Revision: r0p1-01rel0 - Armv7E-M architecture profile - Single precision floating-point unit compliant with the ANSI/IEEE Std 754-2008. • Arm Memory Protection Unit (Arm MPU): <ul style="list-style-type: none"> - Armv7 Protected Memory System Architecture - 8 protect regions • SysTick timer: <ul style="list-style-type: none"> - Driven by SYSTICCLK (LOCO) or ICLK.

Table 1.2 Memory

Feature	Functional description
Code flash memory	Maximum 512 KB of code flash memory. See section 43, Flash Memory in User's Manual.
Data flash memory	8 KB of data flash memory. See section 43, Flash Memory in User's Manual.
Option-setting memory	The option-setting memory determines the state of the MCU after a reset. See section 7, Option-Setting Memory in User's Manual.
Memory Mirror Function (MMF)	The Memory Mirror Function (MMF) can be configured to mirror the desired application image load address in code flash memory to the application image link address in the 23-bit unused memory space (memory mirror space addresses). Your application code is developed and linked to run from this MMF destination address. The application code does not need to know the load location where it is stored in code flash memory. See section 5, Memory Mirror Function (MMF) in User's Manual.
SRAM	On-chip high-speed SRAM with either parity bit or Error Correction Code (ECC). An area in SRAM0 provides error correction capability using ECC. See section 42, SRAM in User's Manual.

Table 1.3 System (1 of 2)

Feature	Functional description
Operating modes	Two operating modes: <ul style="list-style-type: none"> • Single-chip mode • SCI/USB boot mode. See section 3, Operating Modes in User's Manual.
Resets	14 resets: <ul style="list-style-type: none"> • RES pin reset • Power-on reset • VBATT-selected voltage power-on reset • Independent watchdog timer reset • Watchdog timer reset • Voltage monitor 0 reset • Voltage monitor 1 reset • SRAM parity error reset • SRAM ECC error reset • Bus master MPU error reset • Bus slave MPU error reset • Stack pointer error reset • Software reset. See section 6, Resets in User's Manual.
Low Voltage Detection (LVD)	The Low Voltage Detection (LVD) monitors the voltage level input to the VCC pin, and the detection level can be selected using a software program. See section 8, Low Voltage Detection (LVD) in User's Manual.
Clocks	<ul style="list-style-type: none"> • Main clock oscillator (MOSC) • Sub-clock oscillator (SOSC) • High-speed on-chip oscillator (HOCO) • Middle-speed on-chip oscillator (MOCO) • Low-speed on-chip oscillator (LOCO) • PLL frequency synthesizer • IWDT-dedicated on-chip oscillator • Bluetooth-dedicated clock oscillator • Bluetooth-dedicated low-speed on-chip oscillator • Clock out support. See section 9, Clock Generation Circuit in User's Manual.
Clock Frequency Accuracy Measurement Circuit (CAC)	The Clock Frequency Accuracy Measurement Circuit (CAC) counts pulses of the clock to be measured (measurement target clock) within the time generated by the clock to be used as a measurement reference (measurement reference clock), and determines the accuracy depending on whether the number of pulses is within the allowable range. When measurement is complete or the number of pulses within the time generated by the measurement reference clock is not within the allowable range, an interrupt request is generated. See section 10, Clock Frequency Accuracy Measurement Circuit (CAC) in User's Manual.
Interrupt Controller Unit (ICU)	The Interrupt Controller Unit (ICU) controls which event signals are linked to the NVIC/DTC module and DMAC module. The ICU also controls NMI interrupts. See section 14, Interrupt Controller Unit (ICU) in User's Manual.
Key Interrupt Function (KINT)	A key interrupt can be generated by setting the Key Return Mode Register (KRM) and inputting a rising or falling edge to the key interrupt input pins. See section 21, Key Interrupt Function (KINT) in User's Manual.
Low Power Mode	Power consumption can be reduced in multiple ways, such as by setting clock dividers, stopping modules, selecting power control mode in normal operation, and transitioning to low power modes. See section 11, Low Power Modes in User's Manual.
Battery backup function	A battery backup function is provided for partial powering by a battery. The battery powered area includes RTC, SOSC, LOCO, wakeup control, backup memory, VBATT_R low voltage detection, and switch between VCC and VBATT. During normal operation, the battery powered area is powered by the main power supply, which is the VCC pin. When a VCC voltage fall is detected, the power source is switched to the dedicated battery backup power pin, the VBATT pin. When the voltage rises again, the power source is switched from the VBATT pin to the VCC pin. See section 12, Battery Backup Function in User's Manual.
Register write protection	The register write protection function protects important registers from being overwritten because of software errors. See section 13, Register Write Protection in User's Manual.

Table 1.3 System (2 of 2)

Feature	Functional description
Memory Protection Unit (MPU)	Four Memory Protection Units (MPUs) and a CPU stack pointer monitor function are provided for memory protection. See section 16, Memory Protection Unit (MPU) in User's Manual.
Watchdog Timer (WDT)	The Watchdog Timer (WDT) is a 14-bit down-counter that can be used to reset the MCU when the counter underflows because the system has run out of control and is unable to refresh the WDT. In addition, a non-maskable interrupt or interrupt can be generated by an underflow. The refresh-permitted period can be set to refresh the counter and used as the condition for detecting when the system runs out of control. See section 26, Watchdog Timer (WDT) in User's Manual.
Independent Watchdog Timer (IWDT)	The Independent Watchdog Timer (IWDT) consists of a 14-bit down-counter that must be serviced periodically to prevent counter underflow. It can be used to reset the MCU or to generate a non-maskable interrupt/interrupt for a timer underflow. Because the timer operates with an independent, dedicated clock source, it is particularly useful in returning the MCU to a known state as a fail-safe mechanism when the system runs out of control. The IWDT can be triggered automatically on a reset, underflow, refresh error, or by a refresh of the count value in the registers. See section 27, Independent Watchdog Timer (IWDT) in User's Manual.

Table 1.4 Event link

Feature	Functional description
Event Link Controller (ELC)	The Event Link Controller (ELC) uses the interrupt requests generated by various peripheral modules as event signals to connect them to different modules, enabling direct interaction between the modules without CPU intervention. See section 19, Event Link Controller (ELC) in User's Manual.

Table 1.5 Direct memory access

Feature	Functional description
Data Transfer Controller (DTC)	A Data Transfer Controller (DTC) module is provided for transferring data when activated by an interrupt request. See section 18, Data Transfer Controller (DTC) in User's Manual.
DMA Controller (DMAC)	A 4-channel DMA Controller (DMAC) module is provided for transferring data without the CPU. When a DMA transfer request is generated, the DMAC transfers data stored at the transfer source address to the transfer destination address. See section 17, DMA Controller (DMAC) in User's Manual.

Table 1.6 Timers

Feature	Functional description
General PWM Timer (GPT)	The General PWM Timer (GPT) is a 32-bit timer with 4 channels and a 16-bit timer with 3 channels. PWM waveforms can be generated by controlling the up-counter, down-counter, or the up- and down-counter. In addition, PWM waveforms can be generated for controlling brushless DC motors. The GPT can also be used as a general-purpose timer. See section 23, General PWM Timer (GPT) in User's Manual.
Port Output Enable for GPT (POEG)	Use the Port Output Enable for GPT (POEG) function to place the General PWM Timer (GPT) output pins in the output disable state. See section 22, Port Output Enable for GPT (POEG) in User's Manual.
Asynchronous General Purpose Timer (AGT)	The Asynchronous General Purpose Timer (AGT) is a 16-bit timer that can be used for pulse output, external pulse width or period measurement, and counting of external events. This 16-bit timer consists of a reload register and a down-counter. The reload register and the down-counter are allocated to the same address, and they can be accessed with the AGT register. See section 24, Asynchronous General Purpose Timer (AGT) in User's Manual.
Realtime Clock (RTC)	The Realtime Clock (RTC) has two counting modes, calendar count mode and binary count mode, that are controlled by the register settings. For calendar count mode, the RTC has a 100-year calendar from 2000 to 2099 and automatically adjusts dates for leap years. For binary count mode, the RTC counts seconds and retains the information as a serial value. Binary count mode can be used for calendars other than the Gregorian (Western) calendar. See section 25, Realtime Clock (RTC) in User's Manual.

Table 1.7 Communication interfaces (1 of 2)

Feature	Functional description
Serial Communications Interface (SCI)	The Serial Communication Interface (SCI) is configurable to five asynchronous and synchronous serial interfaces: <ul style="list-style-type: none"> • Asynchronous interfaces (UART and asynchronous communications interface adapter (ACIA)) • 8-bit clock synchronous interface • Simple IIC (master-only) • Simple SPI • Smart card interface. The smart card interface complies with the ISO/IEC 7816-3 standard for electronic signals and transmission protocol. SCI0 and SCI1 have FIFO buffers to enable continuous and full-duplex communication, and the data transfer speed can be configured independently using an on-chip baud rate generator. See section 29, Serial Communications Interface (SCI) in User's Manual.
I ² C bus interface (IIC)	The 2-channel I ² C bus interface (IIC) conforms with and provides a subset of the NXP I ² C (Inter-Integrated Circuit) bus interface functions. See section 30, I ² C Bus Interface (IIC) in User's Manual.
Serial Peripheral Interface (SPI)	Two independent Serial Peripheral Interface (SPI) channels are capable of high-speed, full-duplex synchronous serial communications with multiple processors and peripheral devices. See section 32, Serial Peripheral Interface (SPI) in User's Manual.
Controller Area Network (CAN) module	The Controller Area Network (CAN) module provides functionality to receive and transmit data using a message-based protocol between multiple slaves and masters in electromagnetically noisy applications. The CAN module complies with the ISO 11898-1 (CAN 2.0A/CAN 2.0B) standard and supports up to 32 mailboxes, which can be configured for transmission or reception in normal mailbox and FIFO modes. Both standard (11-bit) and extended (29-bit) messaging formats are supported. See section 31, Controller Area Network (CAN) Module in User's Manual.
USB 2.0 Full-Speed (USBFS) module	The USB 2.0 Full-Speed (USBFS) module can operate as a host controller or device controller. The module supports full-speed and low-speed (only for the host controller) transfer as defined in the Universal Serial Bus Specification 2.0. The module has an internal USB transceiver and supports all of the transfer types defined in the Universal Serial Bus Specification 2.0. The USB has buffer memory for data transfer, providing a maximum of 10 pipes. Pipes 1 to 9 can be assigned any endpoint number based on the peripheral devices used for communication or based on the user system. The MCU supports revision 1.2 of the Battery Charging Specification. See section 28, USB 2.0 Full-Speed Module (USBFS) in User's Manual.

Table 1.7 Communication interfaces (2 of 2)

Feature	Functional description
Bluetooth low energy(BLE)	<ul style="list-style-type: none"> On-chip RF transceiver and link layer compliant with the Bluetooth 5.0 Low Energy specification Bit rates: 1 Mbps, 2 Mbps, 500 kbps, and 125 kbps LE Advertising extension support Includes an RF transceiver power supply (selectable as a DC-to-DC converter or linear regulator) On-chip matching circuit to help reduce the number of external parts Transmission power: +4 dBm support

Table 1.8 Analog

Feature	Functional description
14-bit A/D Converter (ADC14)	A 14-bit successive approximation A/D converter is provided. Up to 8 analog input channels are selectable. Temperature sensor output and internal reference voltage are selectable for conversion. The A/D conversion accuracy is selectable from 12-bit and 14-bit conversion making it possible to optimize the tradeoff between speed and resolution in generating a digital value. See section 34, 14-Bit A/D Converter (ADC14) in User's Manual.
12-bit D/A Converter (DAC12)	The 12-bit D/A Converter (DAC12) converts data and includes an output amplifier. See section 35, 12-Bit D/A Converter (DAC12) in User's Manual.
8-bit D/A Converter (DAC8) for ACMPLP	The 8-bit D/A Converter (DAC8) converts data and does not include an output amplifier. The DAC8 is used only as the reference voltage for ACMPLP. See section 39, 8-Bit D/A Converter (DAC8) in User's Manual.
Temperature Sensor (TSN)	The on-chip temperature sensor determines and monitors the die temperature for reliable operation of the device. The sensor outputs a voltage directly proportional to the die temperature, and the relationship between the die temperature and the output voltage is linear. The output voltage is provided to the ADC14 for conversion and can be further used by the end application. See section 36, Temperature Sensor (TSN) in User's Manual.
Low-Power Analog Comparator (ACMPLP)	The Low-Power Analog Comparator (ACMPLP) compares a reference input voltage and analog input voltage. The comparison result can be read by software and also be output externally. The reference voltage can be selected from an input to the CMPREFi(i = 0,1) pin, an internal 8-bit D/A converter output, or the internal reference voltage (Vref) generated internally in the MCU. The ACMPLP response speed can be set before starting an operation. Setting the high-speed mode decreases the response delay time, but increases current consumption. Setting the low-speed mode increases the response delay time, but decreases current consumption. See section 38, Low Power Analog Comparator (ACMPLP) in User's Manual.
Operational Amplifier (OPAMP)	The Operational Amplifier (OPAMP) can be used to amplify small analog input voltages and output the amplified voltages. A differential operational amplifier unit with two input pins and one output pin are provided. See section 37, Operational Amplifier (OPAMP) in User's Manual.

Table 1.9 Human machine interfaces

Feature	Functional description
Segment LCD Controller (SLCDC)	The SLCDC provides the following functions: <ul style="list-style-type: none"> Waveform A or B selectable The LCD driver voltage generator uses an external resistance division method Automatic output of segment and common signals based on automatic display data register read The LCD can be made to blink. See section 44, Segment LCD Controller (SLCDC) in User's Manual.
Capacitive Touch Sensing Unit (CTSU)	The Capacitive Touch Sensing Unit (CTSU) measures the electrostatic capacitance of the touch sensor. Changes in the electrostatic capacitance are determined by software, which enables the CTSU to detect whether a finger is in contact with the touch sensor. The electrode surface of the touch sensor is usually enclosed with an electrical insulator so that a finger does not come into direct contact with the electrode. See section 40, Capacitive Touch Sensing Unit (CTSU) in User's Manual.

Table 1.10 Data processing

Feature	Functional description
Cyclic Redundancy Check (CRC) calculator	The Cyclic Redundancy Check (CRC) calculator generates CRC codes to detect errors in the data. The bit order of CRC calculation results can be switched for LSB-first or MSB-first communication. Additionally, various CRC generation polynomials are available. The snoop function allows monitoring reads from and writes to specific addresses. This function is useful in applications that require CRC code to be generated automatically in certain events, such as monitoring writes to the serial transmit buffer and reads from the serial receive buffer. See section 33, Cyclic Redundancy Check (CRC) Calculator in User's Manual.
Data Operation Circuit (DOC)	The Data Operation Circuit (DOC) compares, adds, and subtracts 16-bit data. See section 41, Data Operation Circuit (DOC) in User's Manual.

Table 1.11 Security

Feature	Functional description
Secure Crypto Engine 5 (SCE5)	<ul style="list-style-type: none"> • Security algorithm: <ul style="list-style-type: none"> - Symmetric algorithm: AES • Other support features: <ul style="list-style-type: none"> - TRNG (True Random Number Generator) - Hash-value generation: GHASH.

1.2 Block Diagram

Figure 1.1 shows a block diagram of the MCU superset. Some individual devices within the group may have a subset of the features.

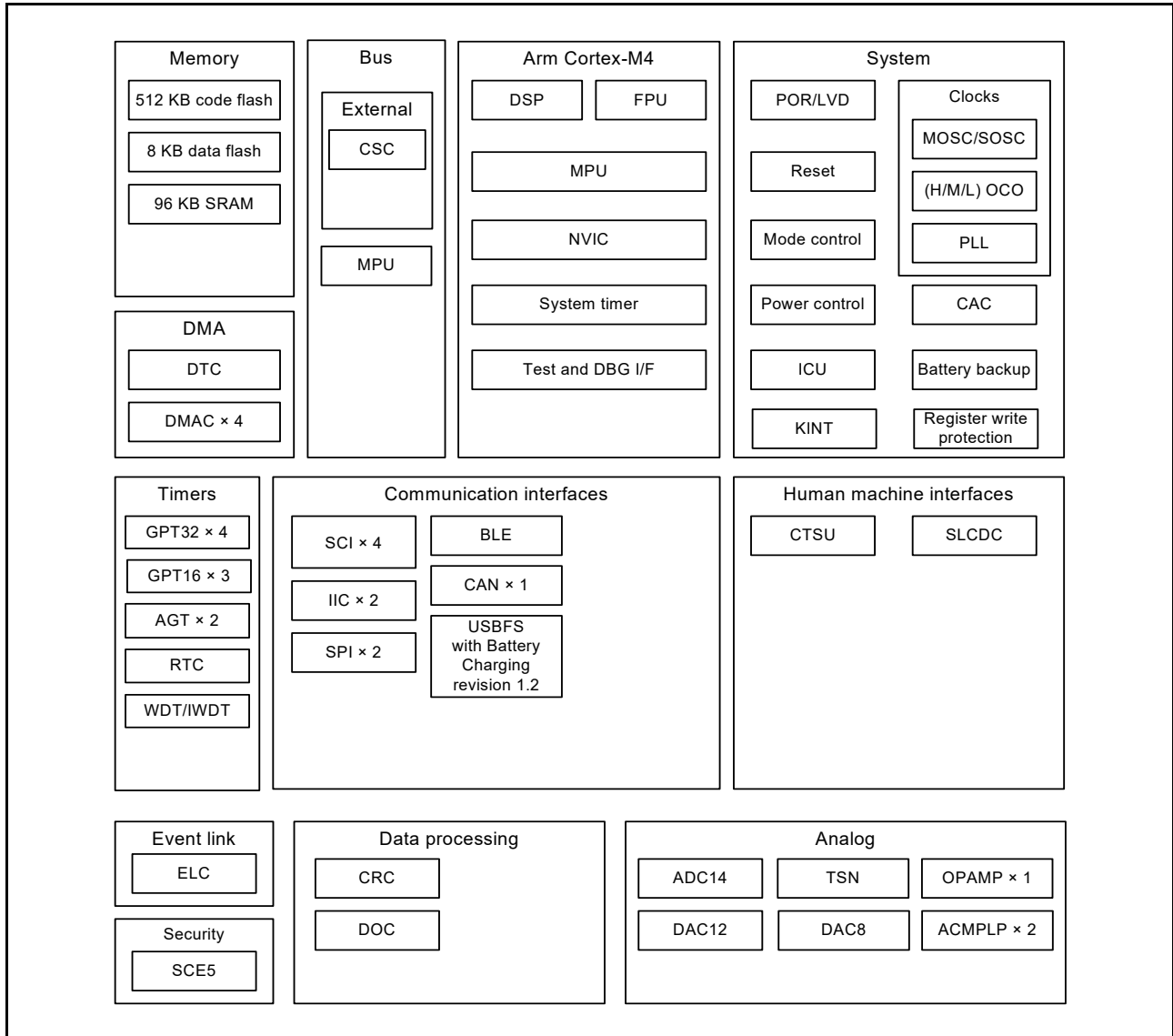

Figure 1.1 Block diagram

1.3 Part Numbering

Figure 1.2 shows how to read the product part number information, including memory capacity, and package type. Table 1.13 shows a product list.

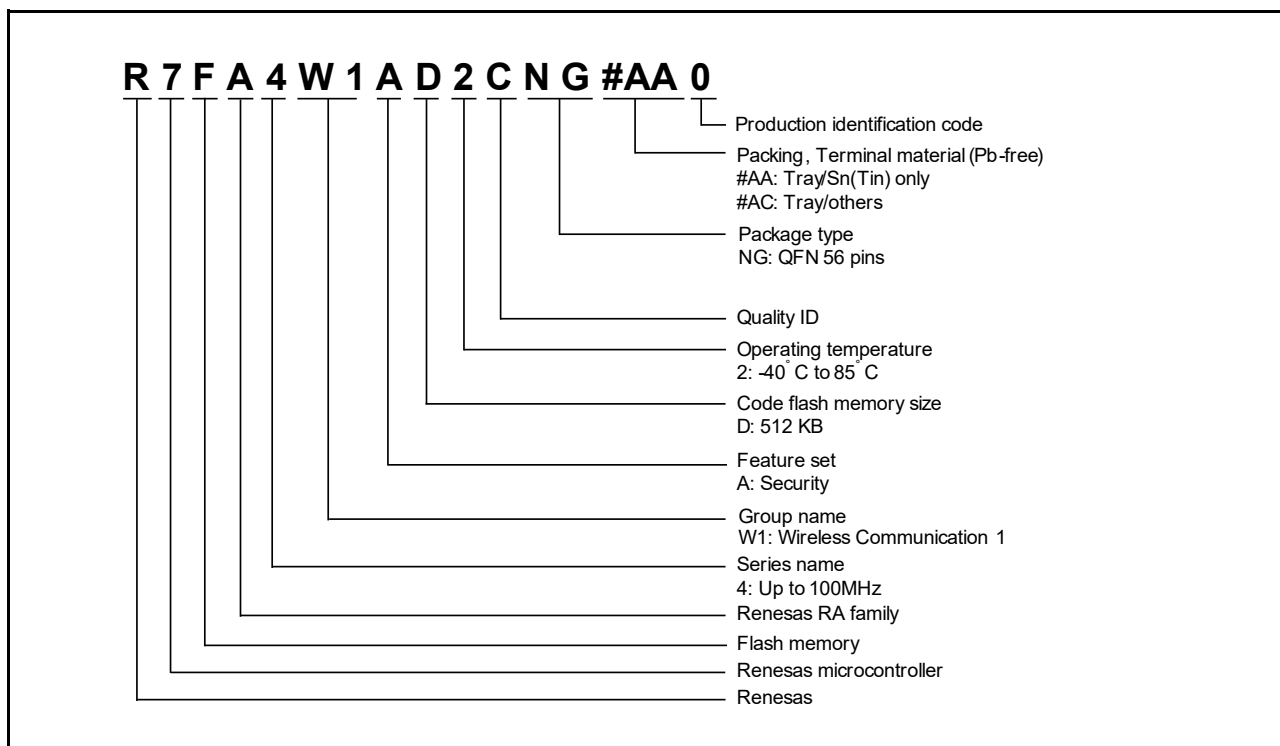

Figure 1.2 Part numbering scheme

Table 1.12 Product list

Product part number	Orderable part number	Code flash	Data flash	SRAM	Operating temperature
R7FA4W1AD2CNG	R7FA4W1AD2CNG#AA0	512 KB	8 KB	96 KB	-40 to +85°C

1.4 Function Comparison

Table 1.13 Function comparison

Part numbers		R7FA4W1AD2CNG
Pin count		56
Package		QFN
Code flash memory		512 KB
Data flash memory		8 KB
SRAM		96 KB
	Parity	80 KB
	ECC	16 KB
System	CPU clock	48 MHz
	Backup registers	512 bytes
	ICU	Yes
	KINT	8
Event control	ELC	Yes
DMA	DTC	Yes
	DMAC	4
Timers	GPT32	4
	GPT16	3
	AGT	2
	RTC	Yes
	WDT/IWDT	Yes
Communication	SCI	6
	IIC	2
	SPI	2
	CAN	1
	USBFS	Yes
	BLE	An RF transceiver and link layer compliant with Bluetooth 5.0 low energy specification
Analog	ADC14	8
	DAC12	1
	DAC8	2
	ACMPLP	2
	OPAMP	1
	TSN	Yes
HMI	SLCDC	4 com × 9 seg
	CTSU	11
Data processing	CRC	Yes
	DOC	Yes
Security		SCE5

1.5 Pin Functions

Function	Signal	I/O	Description
Power supply	VCC	Input	Power supply pin. Connect it to the system power supply. Connect this pin to VSS by a 0.1- μ F capacitor. The capacitor should be placed close to the pin.
	VCL	Input	Connect this pin to the VSS pin by the smoothing capacitor used to stabilize the internal power supply. Place the capacitor close to the pin.
	VSS	Input	Ground pin. Connect it to the system power supply (0 V).
	VBATT	Input	Backup power pin
Clock	XTAL	Output	Pins for a crystal resonator. An external clock signal can be input through the EXTAL pin.
	EXTAL	Input	
	XCIN	Input	Input/output pins for the sub-clock oscillator. Connect a crystal resonator between XCOUT and XCIN.
	XCOUT	Output	
	CLKOUT_RF	Output	Bluetooth-dedicated clock output pin for output of a 1-, 2-, or 4-MHz signal
	XTAL1_RF	Input	Pins for connecting the Bluetooth-dedicated clock oscillator. Connect a 32-MHz oscillator to these pins.
	XTAL2_RF	Output	
CLKOUT	Output	Clock output pin	
Operating mode control	MD	Input	Pins for setting the operating mode. The signal levels on these pins must not be changed during operation mode transition at the time of release from the reset state.
System control	RES	Input	Reset signal input pin. The MCU enters the reset state when this signal goes low.
CAC	CACREF	Input	Measurement reference clock input pin
Interrupt	NMI	Input	Non-maskable interrupt request pin
	IRQ0 to IRQ4, IRQ6, IRQ7, IRQ9, IRQ11, IRQ14, IRQ15	Input	Maskable interrupt request pins
KINT	KR00 to KR07	Input	A key interrupt can be generated by inputting a falling edge to the key interrupt input pins
On-chip debug	TMS	I/O	On-chip emulator pins
	TDI	Input	
	TCK	Input	
	TDO	Output	
	SWDIO	I/O	Serial Wire debug Data Input/Output pin
	SWCLK	Input	Serial Wire Clock pin
	SWO	Output	Serial Wire trace Output pin
Battery backup	VBATWIO0	I/O	Output wakeup signal for the VBATT wakeup control function. External event input for the VBATT wakeup control function.
GPT	GTETRGA, GTETRGB	Input	External trigger input pin
	GTIO0A to GTIOA5A, GTIO8A, GTIO0B to GTIOA5B, GTIO8B	I/O	Input capture, Output capture, or PWM output pin
	GTIU	Input	Hall sensor input pin U
	GTIV	Input	Hall sensor input pin V
	GTIW	Input	Hall sensor input pin W
	GTOUUP	Output	3-phase PWM output for BLDC motor control (positive U phase)
	GTOULO	Output	3-phase PWM output for BLDC motor control (negative U phase)
	GTOVUP	Output	3-phase PWM output for BLDC motor control (positive V phase)
	GTOVLO	Output	3-phase PWM output for BLDC motor control (negative V phase)
	GTOWUP	Output	3-phase PWM output for BLDC motor control (positive W phase)
	GTOWLO	Output	3-phase PWM output for BLDC motor control (negative W phase)
AGT	AGTEE0, AGTEE1	Input	External event input enable
	AGTIO0, AGTIO1	I/O	External event input and pulse output
	AGTO0, AGTO1	Output	Pulse output
	AGTOB0	Output	Output compare match B output

Function	Signal	I/O	Description
RTC	RTCCOUT	Output	Output pin for 1-Hz/64-Hz clock
	RTCCIC0, RTCCIC2	Input	Time capture event input pins
SCI	SCK0,SCK1,SCK4, SCK9	I/O	Input/output pins for the clock (clock synchronous mode)
	RXD0, RXD1, RXD4, RXD9	Input	Input pins for received data (asynchronous mode/clock synchronous mode)
	TXD0, TXD1, TXD4, TXD9	Output	Output pins for transmitted data (asynchronous mode/clock synchronous mode)
	CTS0_RTS0, CTS1_RTS1, CTS4_RTS4, CTS9_RTS9	I/O	Input/Output pins for controlling the start of transmission and reception (asynchronous mode/clock synchronous mode), active-low
	SCL0, SCL1, SCL4, SCL9	I/O	Input/output pins for the IIC clock (simple IIC)
	SDA0, SDA1, SDA4, SDA9	I/O	Input/output pins for the IIC data (simple IIC)
	SCK0, SCK1, SCK4, SCK9	I/O	Input/output pins for the clock (simple SPI)
	MISO0, MISO1, MISO4, MISO9	I/O	Input/output pins for slave transmission of data (simple SPI)
	MOSI0, MOSI1, MOSI4, MOSI9	I/O	Input/output pins for master transmission of data (simple SPI)
	SS0, SS1,SS4,SS9	Input	Slave-select input pins (simple SPI), active-low
IIC	SCL0 to SCL1	I/O	Input/output pins for clock
	SDA0 to SDA1	I/O	Input/output pins for data
SPI	RSPCKA, RSPCKB	I/O	Clock input/output pin
	MOSIA, MOSIB	I/O	Inputs or outputs data output from the master
	MISOA, MISOB	I/O	Inputs or outputs data output from the slave
	SSLA0, SSLB0	I/O	Input or output pin for slave selection
	SSLA1, SSLA2, SSLA3, SSLB1, SSLB3	Output	Output pin for slave selection
CAN	CRX0	Input	Receive data
	CTX0	Output	Transmit data
USBFS	VSS_USB	Input	Ground pins
	VCC_USB_LDO	Input	Power supply pin for USB transceiver. Apply the same voltage as VCC_USB.
	VCC_USB	I/O	Input: Power supply pin for USB transceiver.
	USB_DP	I/O	D+ I/O pin of the USB on-chip transceiver. This pin should be connected to the D+ pin of the USB bus.
	USB_DM	I/O	D- I/O pin of the USB on-chip transceiver. This pin should be connected to the D- pin of the USB bus.
	USB_VBUS	Input	USB cable connection monitor pin. This pin should be connected to VBUS of the USB bus. The VBUS pin status (connected or disconnected) can be detected when the USB module is operating as a device controller.
	USB_VBUSEN	Output	VBUS (5 V) supply enable signal for external power supply chip
	USB_OVRCURA, USB_OVRCURB	Input	External overcurrent detection signals should be connected to these pins.
Analog power supply	AVCC0	Input	Analog block power supply pin
	AVSS0	Input	Analog block power supply ground pin
	VREFH0	Input	Reference power supply pin
	VREFL0	Input	Reference power supply ground pin
ADC14	AN004 to AN006, AN009, AN010, AN017, AN019, AN020	Input	Input pins for the analog signals to be processed by the A/D converter
	ADTRG0	Input	Input pins for the external trigger signals that start the A/D conversion, active-low
DAC12	DA0	Output	Output pins for the analog signals to be processed by the D/A converter

Function	Signal	I/O	Description
Comparator output	VCOUT	Output	Comparator output pin
ACMPLP	CMPREF0, CMPREF1	Input	Reference voltage input pins
	CMPIN0, CMPIN1	Input	Analog voltage input pins
OPAMP	AMP2+	Input	Analog voltage input pins
	AMP2-	Input	Analog voltage input pins
	AMP2O	Output	Analog voltage output pins
CTSU	TS00, TS01, TS03, TS10, TS12, TS13, TS18, TS28, TS30, TS31, TS34	Input	Capacitive touch detection pins (touch pins)
	TSCAP	—	Secondary power supply pin for the touch driver
I/O ports	P004, P010, P011, P014, P015	I/O	General-purpose input/output pins
	P100 to P111	I/O	General-purpose input/output pins
	P200	Input	General-purpose input pin
	P201, P204 to P206, P212, P213	I/O	General-purpose input/output pins
	P214, P215	Input	General-purpose input pins
	P300	I/O	General-purpose input/output pins
	P402, P404, P407, P409, P414	I/O	General-purpose input/output pins
	P501	I/O	General-purpose input/output pins
SLCDC	P914, P915	I/O	General-purpose input/output pins
	VL1, VL2, VL4	I/O	Voltage pin for driving the LCD
	COM0 to COM3	Output	Common signal output pins for the LCD controller/driver
BLE (Bluetooth Low Energy)	SEG6, SEG9, SEG11, SEG12, SEG20, SEG23, SEG49, SEG52, SEG53	Output	Segment signal output pins for the LCD controller/driver
	ANT	I/O	RF single I/O pin for the RF transceiver Set the impedance of the signal line to 50 Ω.
	DCLOUT	Output	RF transceiver power-supply output pin
	DCLIN_A	Input	RF transceiver power-supply output connection pin
	DCLIN_D	Input	RF transceiver power-supply output connection pin
	VCC_RF	Input	RF transceiver power supply pin
	AVCC_RF	Input	RF transceiver power supply pin
VSS_RF	Input	RF transceiver ground pin	

1.6 Pin Assignments

Figure 1.3 shows the pin assignments.

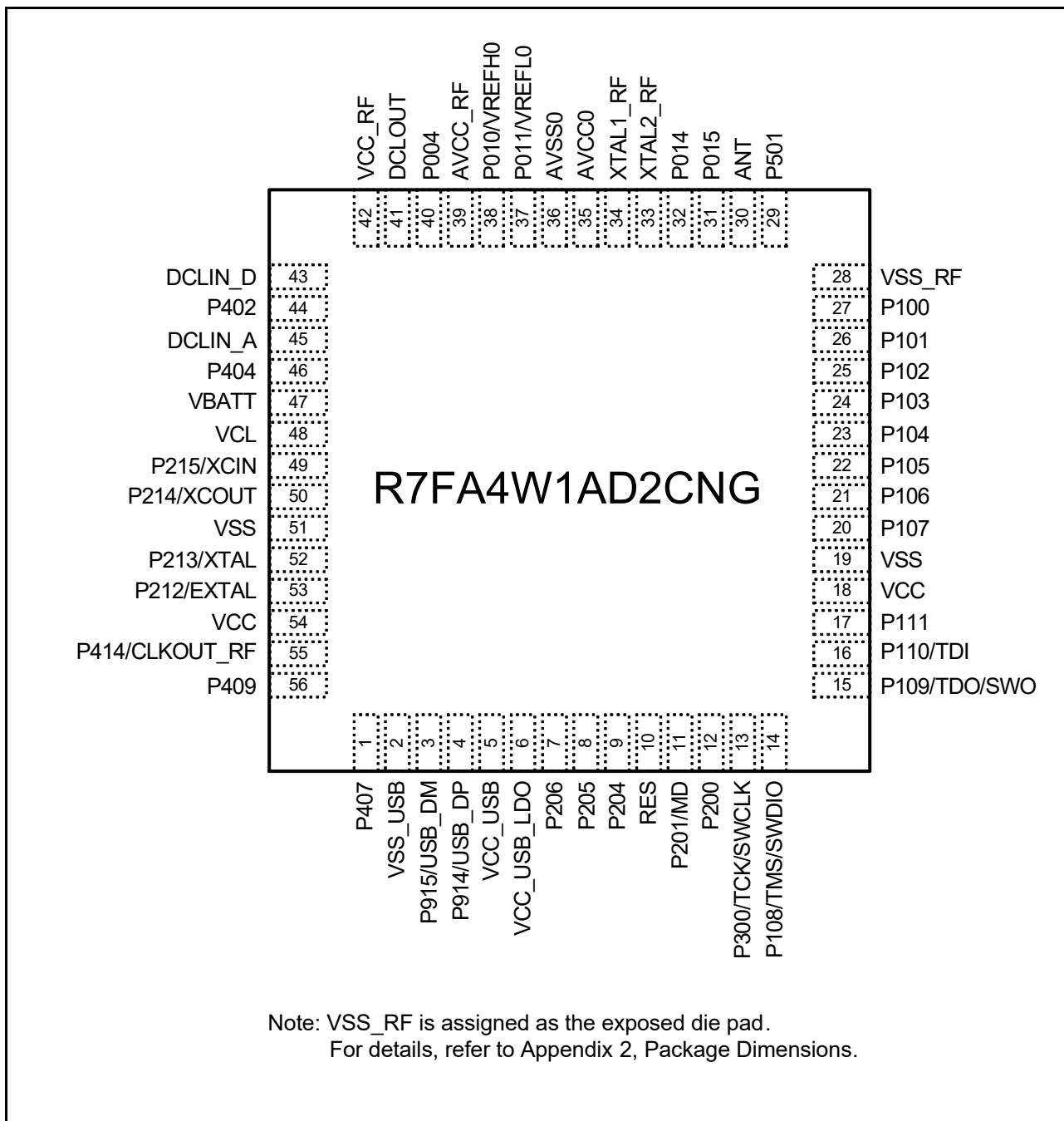

Figure 1.3 Pin assignment for QFN 56-pin (top view)

1.7 Pin Lists

Pin number	Timers						Communication interfaces						Analog			HMI			
	QFN66	Power, System, Clock, Debug, CAC, VBAATT	Interrupt	I/O Ports	AGT	GPT_OPS, POEG	GPT	RTCOU	RTC	USB_VBUS	USBFS, CAN	SCI	IIC	SPI	RF	ADC14	DAC12, OPAMP	ACMPLP	SLCDC
1			P407	AGTIO0					USB_VBUS	CTS4_RTS4 /SS4	SDA0		SSLB3		ADTRG0			SEG11	TS3
2	VSS_USB																		
3			P915						USB_DM										
4			P914						USB_DP										
5	VCC_USB																		
6	VCC_USB LDO																		
7		IRQ0	P206		GTIU				USB_VBUS EN	RXD4/ MISO4/SCL4	SDA1		SSLB1					SEG12	TS1
8	CLKOUT	IRQ1	P205	AGTO1	GTIV	GTIOC4A			USB_OVRC URA	TXD4/ MOSI4/ SDA4/ CTS9_RTS9 /SS9	SCL1		SSLB0					SEG20	TSCAP
9	CACREF		P204	AGTO1	GTIW	GTIOC4B			USB_OVRC URB	SCK4/SCK9	SCL0		RSPCKB					SEG23	TS0
10	RES																		
11	MD		P201																
12		NMI	P200																
13	TCK/ SWCLK		P300		GTOUUP	GTIOC0A							SSLB1						
14	TMS/ SWDIO		P108		GTOULO	GTIOC0B				CTS9_RTS9 /SS9			SSLB0						
15	TDO/ SWO/ CLKOUT		P109		GTOVUP	GTIOC1A			CTX0	SCK1/ TXD9/ MOSI9/ SDA9			MOSIB					SEG52	TS10
16	TDI	IRQ3	P110		GTOVLO	GTIOC1B			CRX0	RXD9/ MISO9/SCL9			MISOB			VCOUT		SEG53	
17		IRQ4	P111			GTIOC3A				SCK9			RSPCKB						TS12
18	VCC																		
19	VSS																		
20		KR07	P107			GTIOC8A													COM3
21		KR06	P106			GTIOC8B							SSLA3						COM2
22		KR05/ IRQ0	P105		GTETRGA	GTIOC1A							SSLA2						COM1 TS34
23		KR04/ IRQ1	P104		GTETRGB	GTIOC1B				RXD0/ MISO0/SCL0			SSLA1						COM0 TS13
24		KR03	P103		GTOWUP	GTIOC2A			CTX0	CTS0_RTS0 /SS0			SSLA0		AN019		CMPREF1	VL4	
25		KR02	P102	AGTO0	GTOWLO	GTIOC2B			CRX0	SCK0			RSPCKA		AN020/ ADTRG0		CMPIN1		
26		KR01/ IRQ1	P101	AGTEE0	GTETRGB	GTIOC5A				TXD0/ MOSI0/ SDA0/ CTS1_RTS1 /SS1	SDA1		MOSIA				CMPREF0	VL2	

Pin number	Timers							Communication interfaces							Analog			HMI	
	Power, System, Clock, Debug, CAC, VBATT	Interrupt	I/O Ports	AGT	GPT_OPS, POEG	GPT	RTC	USBFS, CAN	SCI	IIC	SPI	RF	ADC14	DAC12, OPAMP	ACMPLP	SLCDC	CTSU		
27	QFN66	KR00/ IRQ2	P100	AGTIO0	GTETRGA	GTIOC5B			RXD0/ MISO0/ SCL0/ SCK1	SCL1	MISOA				CMPIN0	VL1			
28												VSS_RF							
29		IRQ11	P501	AGTOB0	GTIV	GTIOC2B		USB_OVRC URA					AN017		CMPIN1	SEG49			
30											ANT								
31		IRQ7	P015										AN010				TS28		
32			P014										AN009	DA0					
33												XTAL2_RF							
34												XTAL1_RF							
35	AVCC0																		
36	AVSS0																		
37	VREFL0	IRQ15	P011										AN006	AMP2+			TS31		
38	VREFH0	IRQ14	P010										AN005	AMP2-			TS30		
39												AVCC_RF							
40		IRQ3	P004										AN004	AMP20					
41												DCLOUT							
42												VCC_RF							
43												DCLIN_D							
44	VBATWIO 0	IRQ4	P402	AGTIO0/ AGTIO1			RTCIC0	CRX0	RXD1/ MISO1/SCL1							SEG6	TS18		
45													DCLIN_A						
46			P404			GTIOC3B	RTCIC2												
47	VBATT																		
48	VCL																		

Pin number	Timers				Communication interfaces								Analog			HMI		
	QFN66	Power, System, Clock, Debug, CAC, VBATT	Interrupt	I/O Ports	AGT	GPT_OPS, POEG	GPT	RTC	USBFS, CAN	SCI	IIC	SPI	RF	ADC14	DAC12, OPAMP	ACMPLP	SLCDC	CTSU
49	XCIN		P215															
50	XCOUT		P214															
51	VSS																	
52	XTAL	IRQ2	P213		GTETRGA	GTIOC0A												
53	EXTAL	IRQ3	P212	AGTEE1	GTETRGB	GTIOC0B												
54	VCC																	
55		IRQ9	P414			GTIOC0B						SSLA1	CLKOUT_ RF					
56		IRQ6	P409		GTOWUP	GTIOC5A		USB_EXICE N									SEG9	

2. Electrical Characteristics

Unless otherwise specified, the electrical characteristics of the MCU are defined under the following conditions:

$VCC^{*1} = AVCC0 = VCC_USB^{*2} = VCC_USB_LDO^{*2} = VCC_RF = AVCC_RF = 1.8$ to $3.6V$, $VREFH0 = 1.8$ to $AVCC0$, $VBATT = 1.8$ to $3.6V$, $VSS = AVSS0 = VREFL0 = VSS_RF = VSS_USB = 0V$, $T_a = T_{opr}$

Note 1. The typical condition is set to $VCC = 3.3V$.

Note 2. When USBFS is not used.

Figure 2.1 shows the timing conditions.

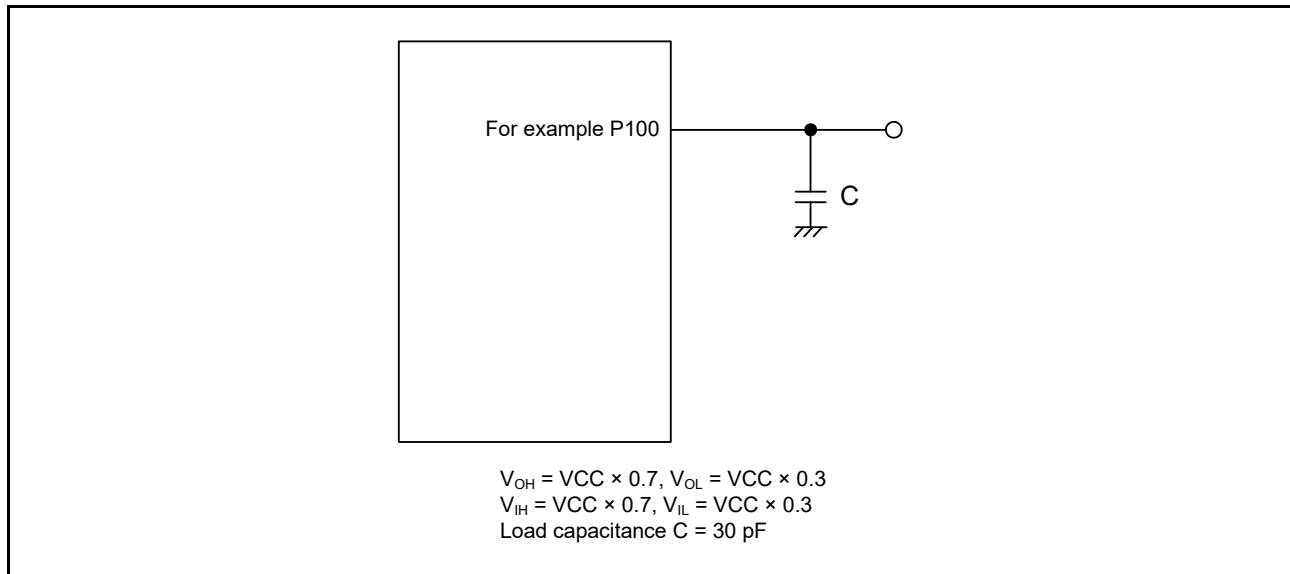

Figure 2.1 Input or output timing measurement conditions

The measurement conditions of timing specifications in each peripheral are recommended for the best peripheral operation. However, make sure to adjust driving abilities of each pin to meet your conditions.

Each function pin used for the same function must select the same drive ability. If the I/O drive ability of each function pin is mixed, the AC specification of each function is not guaranteed.

2.1 Absolute Maximum Ratings

Table 2.1 Absolute maximum ratings

Parameter	Symbol	Value	Unit	
Power supply voltage	VCC	-0.5 to +4.0	V	
Input voltage	5V-tolerant ports*1	V_{in}	-0.3 to +6.5	V
	P004, P010, P011, P014, P015	V_{in}	-0.3 to AVCC0 + 0.3	V
	ANT	V_{in}	-1.0 to +1.4	V
	XTAL1_RF, XTAL2_RF	V_{in}	-0.3 to +1.4	V
	DCLIN_A, DCLIN_D	V_{in}	-0.3 to +2.2	V
	Others	V_{in}	-0.3 to VCC + 0.3	V
Reference power supply voltage	VREFH0	-0.3 to +4.0	V	
VBATT power supply voltage	VBATT	-0.5 to +4.0	V	
Analog power supply voltage	AVCC0	-0.5 to +4.0	V	
	VCC_RF	-0.3 to +4.0	V	
	AVCC_RF	-0.3 to +4.0	V	
USB power supply voltage	VCC_USB	-0.5 to +4.0	V	
	VCC_USB_LDO	-0.5 to +4.0	V	
Analog input voltage	When AN004 to AN006, AN009, AN010 are used	V_{AN}	-0.3 to AVCC0 + 0.3	V
	When AN017, AN019, AN020 are used		-0.3 to VCC + 0.3	V
LCD voltage	VL1 voltage	V_{L1}	-0.3 to +2.8	V
	VL2 voltage	V_{L2}	-0.3 to +4.0	V
	VL4 voltage	V_{L4}	-0.3 to +4.0	V
Operating temperature*2	T_{opr}	-40 to +85	°C	
Storage temperature	T_{stg}	-55 to +125	°C	

Note 1. Ports P205, P206, P402, P407 are 5V-tolerant.

Note 2. See [section 2.2.1, Tj/Ta Definition](#).

Caution: Permanent damage to the MCU may result if absolute maximum ratings are exceeded.

To preclude any malfunctions due to noise interference, insert capacitors of high frequency characteristics between the VCC and VSS pins, between the AVCC0 and AVSS0 pins, between VCC_RF and VSS_RF pins, between the AVDD_RF and VSS_RF pins, between the VCC_USB and VSS_USB pins, between the VREFH0 and VREFL0 pins. Place capacitors with values of about 2.2 μ F in the case of the VCC_RF pin and about 0.1 μ F otherwise as close as possible to every power supply pin, and use the shortest and thickest possible traces for the connections. Also, connect capacitors as stabilization capacitance.

Connect the VCL pin to a VSS pin by a 4.7 μ F capacitor. The capacitor must be placed close to the pin.

Do not input signals or an I/O pull-up power supply while the device is not powered. The current injection that results from input of such a signal or I/O pull-up might cause malfunction and the abnormal current that passes in the device at this time might cause degradation of internal elements.

Table 2.2 Recommended operating conditions

Parameter	Symbol	Value	Min	Typ	Max	Unit
Power supply voltages	VCC*1, *2	When USBFS is not used	1.8	-	3.6	V
		When USBFS is used USB Regulator Disable	VCC_USB	-	3.6	V
	VSS		-	0	-	V
USB power supply voltages	VCC_USB	When USBFS is not used	-	VCC	-	V
		When USBFS is used USB Regulator Disable (Input)	3.0	3.3	3.6	V
	VCC_USB_LDO	When USBFS is not used	-	VCC	-	V
		When USBFS is used	-	VCC	-	V
	VSS_USB		-	0	-	V
VBATT power supply voltage	VBATT	When the battery backup function is not used	-	VCC	-	V
		When the battery backup function is used	1.8	-	3.6	V
Analog power supply voltages	AVCC0*1, *2		1.8	-	3.6	V
	AVSS0		-	0	-	V
	VREFH0	When used as ADC14 Reference	1.8	-	AVCC0	V
	VREFL0		-	0	-	V
BLE power supply voltages	VCC_RF*3		1.8	-	3.6	V
	AVCC_RF*3		1.8	-	3.6	
	VSS_RF		-	0	-	

Note: Bluetooth power supply voltage

VCC_RF *3 1.8 - 3.6 V

Note: AVCC_RF *3 1.8 - 3.6 V

Note: VCC_RF - 0 - V

Note 1. Use AVCC0 and VCC under the following conditions:

AVCC0 and VCC can be set individually within the operating range when $VCC \geq 2.2\text{ V}$ and $AVCC0 \geq 2.2\text{ V}$

$AVCC0 = VCC$ when $VCC < 2.2\text{ V}$ or $AVCC0 < 2.2\text{ V}$

Note 2. When powering on the VCC and AVCC0 pins, power them on at the same time or the VCC pin first and then the AVCC0 pin.

Note 3. Use $VCC = VCC_RF = AVCC_RF$

2.2 DC Characteristics

2.2.1 Tj/Ta Definition

Table 2.3 DC characteristics

Conditions: Products with operating temperature (T_a) -40 to $+85^\circ\text{C}$

Parameter	Symbol	Typ	Max	Unit	Test conditions
Permissible junction temperature	Tj	-	105*1	$^\circ\text{C}$	High-speed mode Middle-speed mode Low-voltage mode Low-speed mode Subosc-speed mode

Note: Make sure that $T_j = T_a + \theta_j a \times \text{total power consumption (W)}$, where total power consumption = $(V_{CC} - V_{OH}) \times \Sigma I_{OH} + V_{OL} \times \Sigma I_{OL} + I_{CCmax} \times V_{CC}$.

Note 1. The upper limit of operating temperature is 85°C . For details, see [section 1.3, Part Numbering](#). If the part number shows the operation temperature at 85°C , then the maximum value of Tj is 105°C .

2.2.2 I/O V_{IH} , V_{IL}

Table 2.4 I/O V_{IH} , V_{IL} (1)

Conditions: $V_{CC} = AV_{CC0} = V_{CC_USB} = V_{CC_USB_LDO} = 2.7$ to 3.6V , $V_{BATT} = 1.8$ to 3.6V , $V_{SS} = AV_{SS0} = 0\text{V}$

Parameter		Symbol	Min	Typ	Max	Unit	Test conditions
Schmitt trigger input voltage	IIC*1	V_{IH}	$V_{CC} \times 0.7$	-	5.8	V	-
		V_{IL}	-	-	$V_{CC} \times 0.3$		
		ΔV_T	$V_{CC} \times 0.05$	-	-		
	RES, NMI Other peripheral input pins excluding IIC	V_{IH}	$V_{CC} \times 0.8$	-	-		
		V_{IL}	-	-	$V_{CC} \times 0.2$		
		ΔV_T	$V_{CC} \times 0.1$	-	-		
Input voltage (except for Schmitt trigger input pin)	5V-tolerant ports*2	V_{IH}	$V_{CC} \times 0.8$	-	5.8		
		V_{IL}	-	-	$V_{CC} \times 0.2$		
	P914, P915	V_{IH}	$V_{CC_USB} \times 0.8$	-	$V_{CC_USB} + 0.3$		
		V_{IL}	-	-	$V_{CC_USB} \times 0.2$		
	P004, P010	V_{IH}	$AV_{CC0} \times 0.8$	-	-		
		V_{IL}	-	-	$AV_{CC0} \times 0.2$		
	EXTAL Input ports pins except for P004, P010, P914, P915	V_{IH}	$V_{CC} \times 0.8$	-	-		
		V_{IL}	-	-	$V_{CC} \times 0.2$		
	When V_{BATT} power supply is selected	P402	V_{IH}	$V_{BATT} \times 0.8$	-	$V_{BATT} + 0.3$	
			V_{IL}	-	-	$V_{BATT} \times 0.2$	
ΔV_T			$V_{BATT} \times 0.05$	-	-		

Note 1. P205, P206, P407 (total 3 pins).

Note 2. P205, P206, P402, P407 (total 4 pins).

Table 2.5 I/O V_{IH} , V_{IL} (2)Conditions: $V_{CC} = AV_{CC0} = V_{CC_USB} = V_{CC_USB_LDO} = 1.8$ to 2.7 V, $V_{BATT} = 1.8$ to 3.6 V, $V_{SS} = AV_{SS0} = 0$ V

Parameter		Symbol	Min	Typ	Max	Unit	Test conditions
Schmitt trigger input voltage	RES, NMI Peripheral input pins	V_{IH}	$V_{CC} \times 0.8$	-	-	V	-
		V_{IL}	-	-	$V_{CC} \times 0.2$		
		ΔV_T	$V_{CC} \times 0.01$	-	-		
Input voltage (except for Schmitt trigger input pin)	5V-tolerant ports*1	V_{IH}	$V_{CC} \times 0.8$	-	5.8		
		V_{IL}	-	-	$V_{CC} \times 0.2$		
	P914, P915	V_{IH}	$V_{CC_USB} \times 0.8$	-	$V_{CC_USB} + 0.3$		
		V_{IL}	-	-	$V_{CC_USB} \times 0.2$		
	P004, P010	V_{IH}	$AV_{CC0} \times 0.8$	-	-		
		V_{IL}	-	-	$AV_{CC0} \times 0.2$		
	EXTAL Input ports pins except for P004, P010	V_{IH}	$V_{CC} \times 0.8$	-	-		
		V_{IL}	-	-	$V_{CC} \times 0.2$		
When V_{BATT} power supply is selected	P402, P404	V_{IH}	$V_{BATT} \times 0.8$	-	$V_{BATT} + 0.3$		
		V_{IL}	-	-	$V_{BATT} \times 0.2$		
		ΔV_T	$V_{BATT} \times 0.01$	-	-		

Note 1. P205, P206, P402, P407 (total 4 pins).

2.2.3 I/O I_{OH} , I_{OL} **Table 2.6** I/O I_{OH} , I_{OL}

Conditions: VCC = AVCC0 = VCC_USB = VCC_USB_LDO = 1.8 to 3.6 V

Parameter			Symbol	Min	Typ	Max	Unit	
Permissible output current (average value per pin)	Ports P212, P213	-	I_{OH}	-	-	-4.0	mA	
			I_{OL}	-	-	4.0	mA	
	Port P409	Low drive*1	I_{OH}	-	-	-4.0	mA	
			I_{OL}	-	-	4.0	mA	
		Middle drive*2 VCC = 2.7 to 3.0 V	I_{OH}	-	-	-8.0	mA	
			I_{OL}	-	-	8.0	mA	
		Middle drive*2 VCC = 3.0 to 3.6 V	I_{OH}	-	-	-20.0	mA	
			I_{OL}	-	-	20.0	mA	
	Ports P100 to P111, P201, P204, P300, P501 (total 16 pins)	Low drive*1	I_{OH}	-	-	-4.0	mA	
			I_{OL}	-	-	4.0	mA	
		Middle drive*2	I_{OH}	-	-	-4.0	mA	
			I_{OL}	-	-	8.0	mA	
	Ports P914, P915	-	I_{OH}	-	-	-4.0	mA	
			I_{OL}	-	-	4.0	mA	
	Other output pin*3	Low drive*1	I_{OH}	-	-	-4.0	mA	
			I_{OL}	-	-	4.0	mA	
		Middle drive*2	I_{OH}	-	-	-8.0	mA	
			I_{OL}	-	-	8.0	mA	
	Permissible output current (Max value per pin)	Ports P212, P213	-	I_{OH}	-	-	-4.0	mA
				I_{OL}	-	-	4.0	mA
Port P409		Low drive*1	I_{OH}	-	-	-4.0	mA	
			I_{OL}	-	-	4.0	mA	
		Middle drive*2 VCC = 2.7 to 3.0 V	I_{OH}	-	-	-8.0	mA	
			I_{OL}	-	-	8.0	mA	
		Middle drive*2 VCC = 3.0 to 3.6 V	I_{OH}	-	-	-20.0	mA	
			I_{OL}	-	-	20.0	mA	
Ports P100 to P111, P201, P204, P300, P501 (total 16 pins)		Low drive*1	I_{OH}	-	-	-4.0	mA	
			I_{OL}	-	-	4.0	mA	
		Middle drive*2	I_{OH}	-	-	-4.0	mA	
			I_{OL}	-	-	8.0	mA	
Ports P914, P915		-	I_{OH}	-	-	-4.0	mA	
			I_{OL}	-	-	4.0	mA	
Other output pin*3		Low drive*1	I_{OH}	-	-	-4.0	mA	
			I_{OL}	-	-	4.0	mA	
		Middle drive*2	I_{OH}	-	-	-8.0	mA	
			I_{OL}	-	-	8.0	mA	
Permissible output current (max value total pins)		Total of ports P004, P010		$\Sigma I_{OH} \text{ (max)}$	-	-	-30	mA
				$\Sigma I_{OL} \text{ (max)}$	-	-	30	mA
	Ports P914, P915		$\Sigma I_{OH} \text{ (max)}$	-	-	-4.0	mA	
			$\Sigma I_{OL} \text{ (min)}$	-	-	4.0	mA	
	Total of all output pin*5		$\Sigma I_{OH} \text{ (max)}$	-	-	-60	mA	
			$\Sigma I_{OL} \text{ (max)}$	-	-	60	mA	

Caution: To protect the reliability of the MCU, the output current values should not exceed the values in this table. The average output current indicates the average value of current measured during 100 μ s.

- Note 1. This is the value when low driving ability is selected with the Port Drive Capability bit in PmnPFS register.
 Note 2. This is the value when middle driving ability is selected with the Port Drive Capability bit in PmnPFS register.
 Note 3. Except for ports P200, P214, P215, which are input ports.
 Note 4. This is the value when middle driving ability for IIC Fast-mode is selected with the Port Drive Capability bit in PmnPFS register.
 Note 5. For details on the permissible output current used with CTSU, see [section 2.11, CTSU Characteristics](#).

2.2.4 I/O V_{OH} , V_{OL} , and Other Characteristics

Table 2.7 I/O V_{OH} , V_{OL} (1)

Conditions: $V_{CC} = AV_{CC0} = V_{CC_USB} = V_{CC_USB_LDO} = 2.7$ to 3.6 V

Parameter	Symbol	Min	Typ	Max	Unit	Test conditions	
Output voltage	IIC*1	V_{OL}	-	-	0.4	V	$I_{OL} = 3.0$ mA
		$V_{OL}^{*2,*5}$	-	-	0.6		$I_{OL} = 6.0$ mA
Ports P409*2, *3	V_{OH}	$V_{CC} - 1.0$	-	-	-	V	$I_{OH} = -20$ mA $V_{CC} = 3.3$ V
		V_{OL}	-	-	1.0		$I_{OL} = 20$ mA $V_{CC} = 3.3$ V
Ports P004, P010	Low drive	V_{OH}	$AV_{CC0} - 0.5$	-	-	V	$I_{OH} = -1.0$ mA
		V_{OL}	-	-	0.5		$I_{OL} = 1.0$ mA
	Middle drive	V_{OH}	$AV_{CC0} - 0.5$	-	-	V	$I_{OH} = -2.0$ mA
		V_{OL}	-	-	0.5		$I_{OL} = 2.0$ mA
Ports P914, P915	V_{OH}	$V_{CC_USB} - 0.5$	-	-	-	V	$I_{OH} = -1.0$ mA
		V_{OL}	-	-	0.5		$I_{OL} = 1.0$ mA
Other output pins *4, *6	Low drive	V_{OH}	$V_{CC} - 0.5$	-	-	V	$I_{OH} = -1.0$ mA
		V_{OL}	-	-	0.5		$I_{OL} = 1.0$ mA
	Middle drive*5	V_{OH}	$V_{CC} - 0.5$	-	-	V	$I_{OH} = -2.0$ mA
		V_{OL}	-	-	0.5		$I_{OL} = 2.0$ mA

- Note 1. P100, P101, P204, P205, P206, P407 (total 6 pins).
 Note 2. This is the value when middle driving ability is selected with the Port Drive Capability bit in PmnPFS register.
 Note 3. Based on characterization data, not tested in production.
 Note 4. Except for ports P200, P214, P215, which are input ports.
 Note 5. Except for P212, P213.
 Note 6. This excludes the CLKOUT_RF pin.

Table 2.8 I/O V_{OH} , V_{OL} (2)

Conditions: $V_{CC} = AV_{CC0} = V_{CC_USB} = V_{CC_USB_LDO} = 1.8$ to 2.7 V

Parameter	Symbol	Min	Typ	Max	Unit	Test conditions			
Output voltage	Ports P004, P010	Low drive	V_{OH}	$AV_{CC0} - 0.3$	-	-	V	$I_{OH} = -0.5$ mA	
			V_{OL}	-	-	0.3		$I_{OL} = 0.5$ mA	
		Middle drive	V_{OH}	$AV_{CC0} - 0.3$	-	-		V	$I_{OH} = -1.0$ mA
			V_{OL}	-	-	0.3			$I_{OL} = 1.0$ mA
	Ports P914, P915	V_{OH}	$V_{CC_USB} - 0.3$	-	-	-	V	$I_{OH} = -0.5$ mA	
			V_{OL}	-	-	0.3		$I_{OL} = 0.5$ mA	
	Other output pins *1, *3	Low drive	V_{OH}	$V_{CC} - 0.3$	-	-	V	$I_{OH} = -0.5$ mA	
			V_{OL}	-	-	0.3		$I_{OL} = 0.5$ mA	
Middle drive*2		V_{OH}	$V_{CC} - 0.3$	-	-	V	$I_{OH} = -1.0$ mA		
		V_{OL}	-	-	0.3		$I_{OL} = 1.0$ mA		

- Note 1. Except for ports P200, P214, P215, which are input ports.
 Note 2. Except for P212, P213.
 Note 3. This excludes the CLKOUT_RF pin.

Table 2.9 I/O V_{OH} , V_{OL} (3)

Conditions: $3.0V \leq VCC = AVCC0 = VCC_USB = VCC_USB_LDO = VCC_RF = AVCC_RF \leq 3.6 V$

Parameter	Symbol	Min	Max	Unit	Test conditions
Output low	CLKOUT_RF	V_{OL}	-	0.3	V $I_{OL} = 0.5 \text{ mA}$
Output high	CLKOUT_RF	V_{OH}	$VCC_RF - 0.3$	-	V $I_{OH} = -0.5 \text{ mA}$

Table 2.10 I/O other characteristics

Conditions: $VCC = AVCC0 = 1.8 \text{ to } 3.6 V$

Parameter	Symbol	Min	Typ	Max	Unit	Test conditions
Input leakage current	RES, P200, P214, P215	$ I_{in} $	-	-	1.0	μA $V_{in} = 0 V$ $V_{in} = VCC$
Three-state leakage current (off state)	5V-tolerant ports	$ I_{TSI} $	-	-	1.0	μA $V_{in} = 0 V$ $V_{in} = 5.8 V$
	Other ports (except for ports P200, P214, P215 and 5 V tolerant)		-	-	1.0	μA $V_{in} = 0 V$ $V_{in} = VCC$
Input pull-up resistor	All ports (except for ports P200, P214, P215, P914, P915)	R_U	10	20	50	$k\Omega$ $V_{in} = 0 V$
Input capacitance	P914, P915, P100 to P103, P111, P200	C_{in}	-	-	30	pF $V_{in} = 0 V$ $f = 1 \text{ MHz}$ $T_a = 25^\circ C$
	Other input pins		-	-	15	

2.2.5 I/O Pin Output Characteristics of Low Drive Capacity

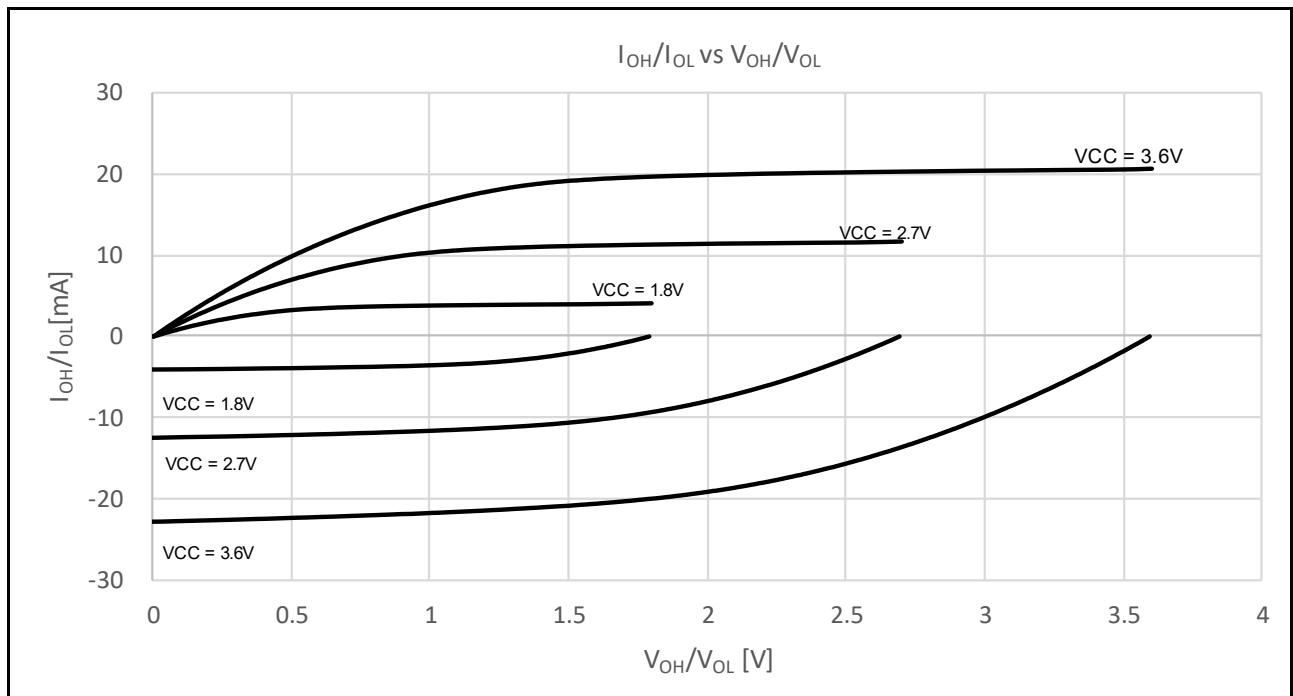

Figure 2.2 V_{OH}/V_{OL} and I_{OH}/I_{OL} voltage characteristics at $T_a = 25^\circ C$ when low drive output is selected (reference data)

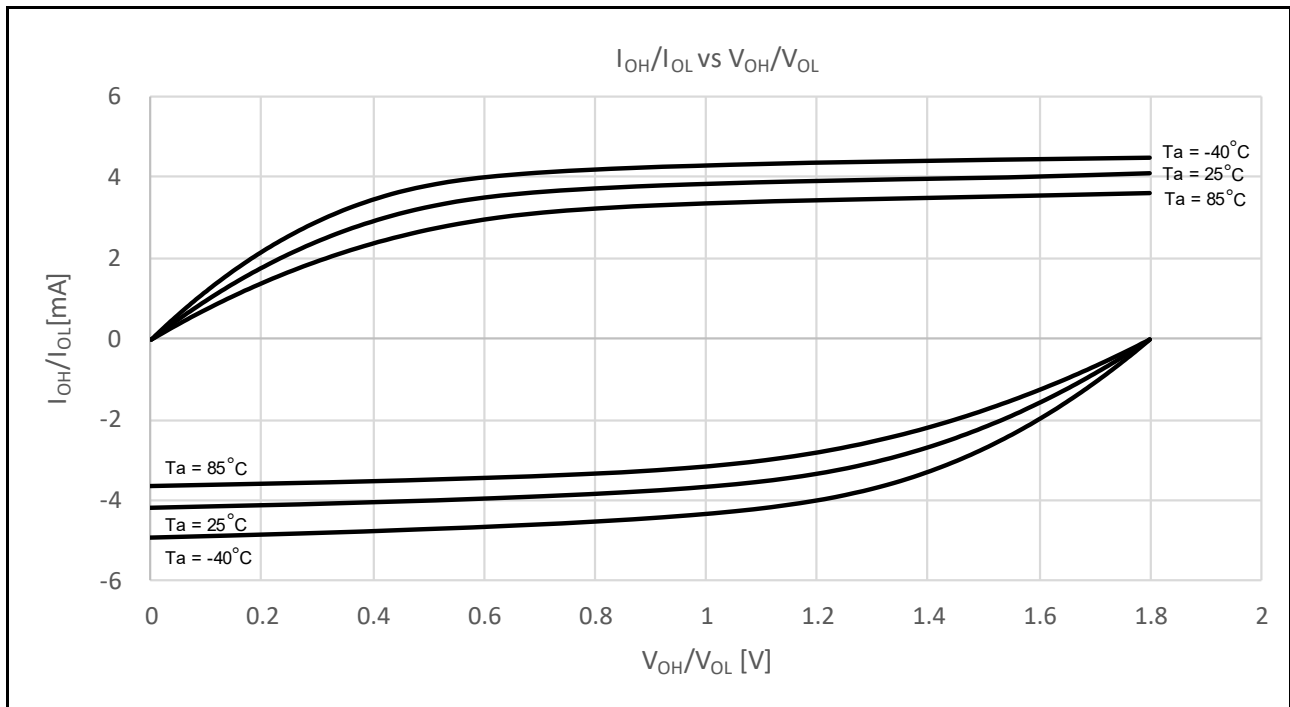

Figure 2.3 V_{OH}/V_{OL} and I_{OH}/I_{OL} temperature characteristics at $V_{CC} = 1.8$ V when low drive output is selected (reference data)

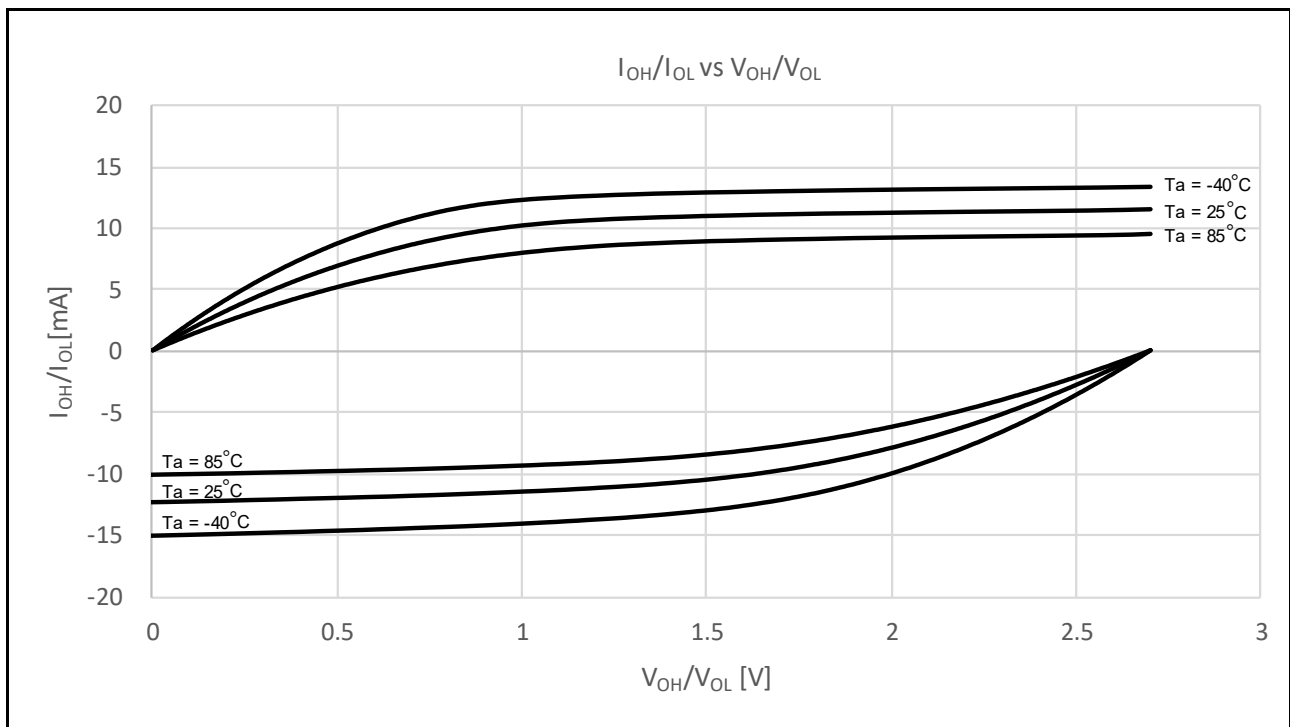

Figure 2.4 V_{OH}/V_{OL} and I_{OH}/I_{OL} temperature characteristics at $V_{CC} = 2.7$ V when low drive output is selected (reference data)

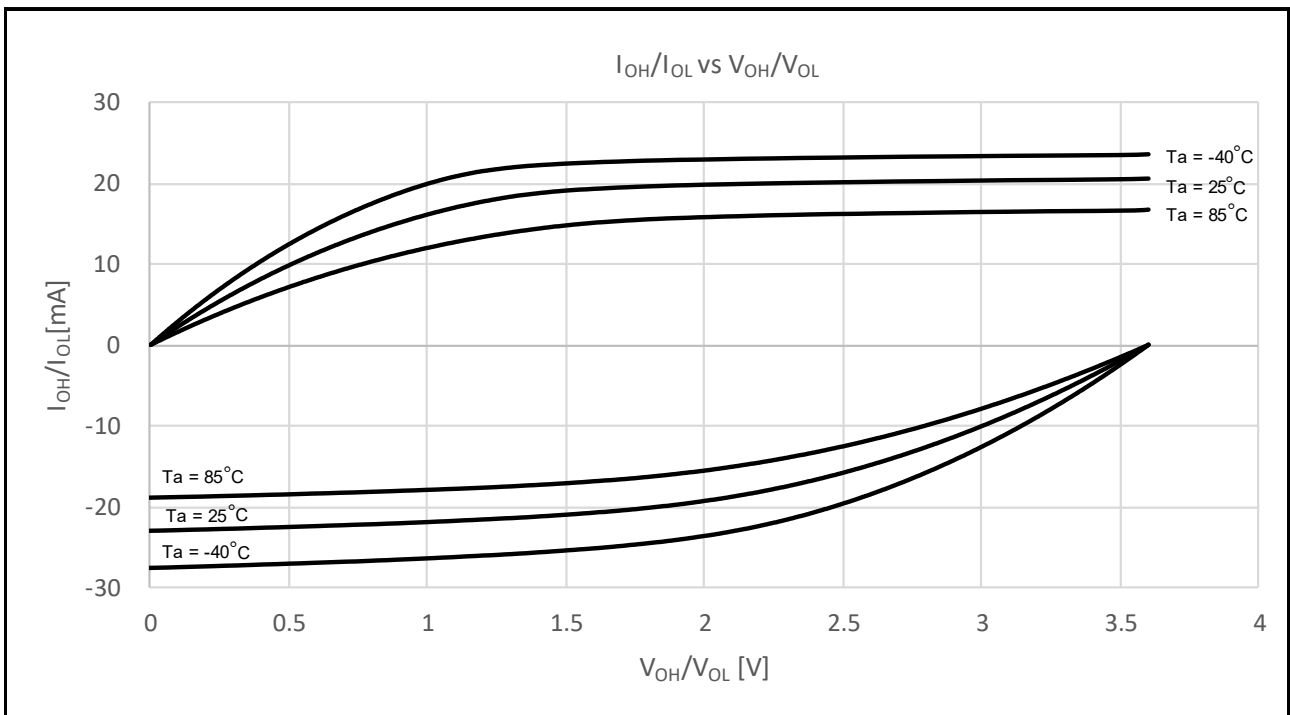

Figure 2.5 V_{OH}/V_{OL} and I_{OH}/I_{OL} temperature characteristics at $V_{CC} = 3.6\text{ V}$ when low drive output is selected (reference data)

2.2.6 I/O Pin Output Characteristics of Middle Drive Capacity

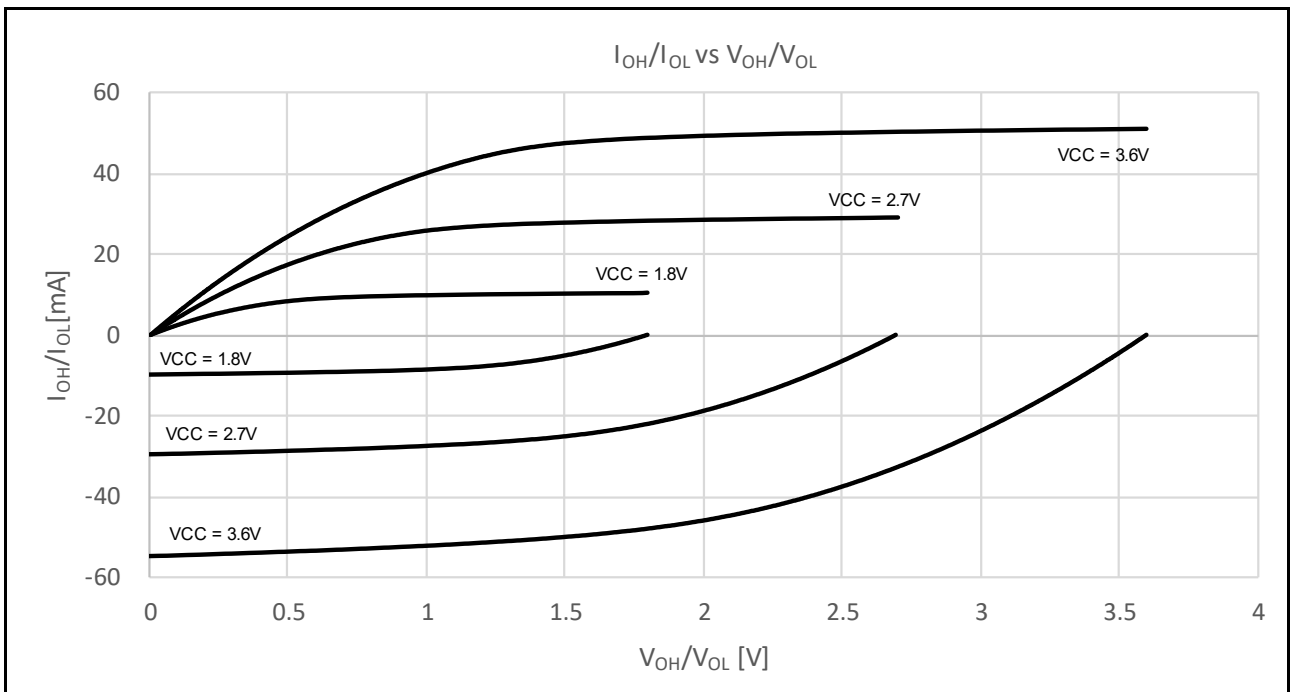

Figure 2.6 V_{OH}/V_{OL} and I_{OH}/I_{OL} voltage characteristics at $T_a = 25^\circ\text{C}$ when middle drive output is selected (reference data)

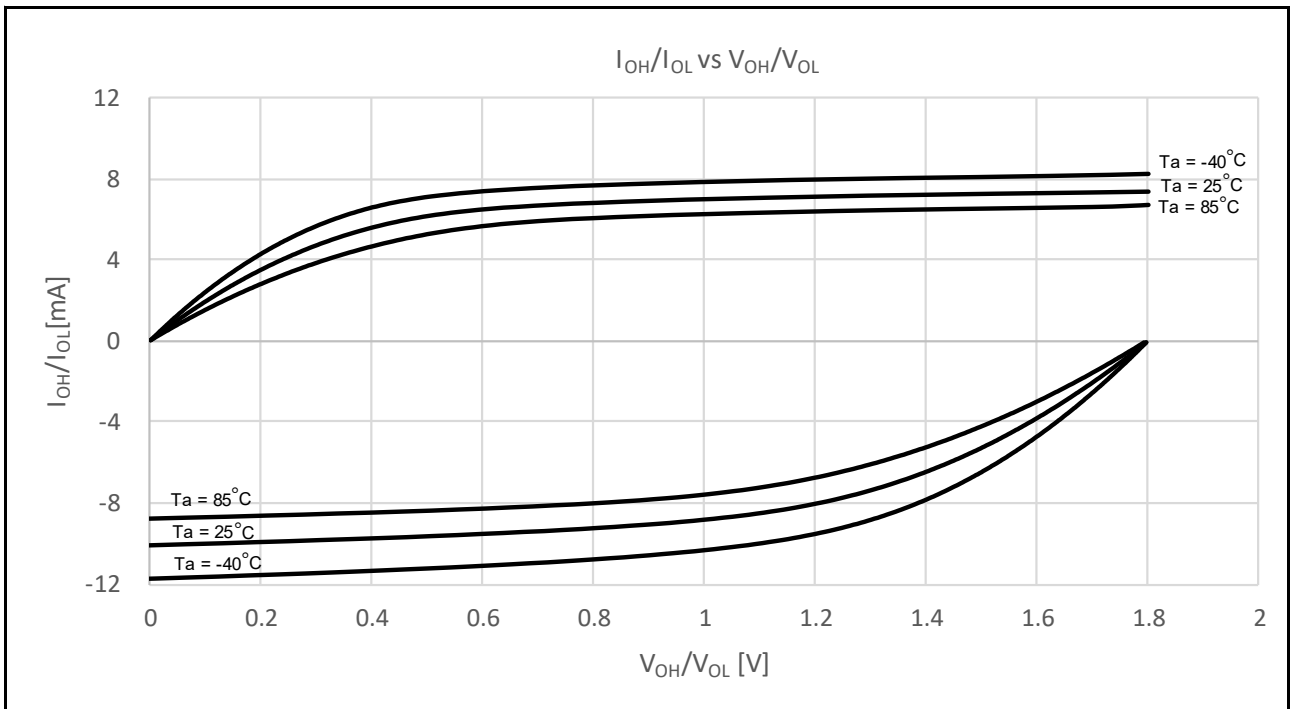

Figure 2.7 V_{OH}/V_{OL} and I_{OH}/I_{OL} temperature characteristics at $V_{CC} = 1.8$ V when middle drive output is selected (reference data)

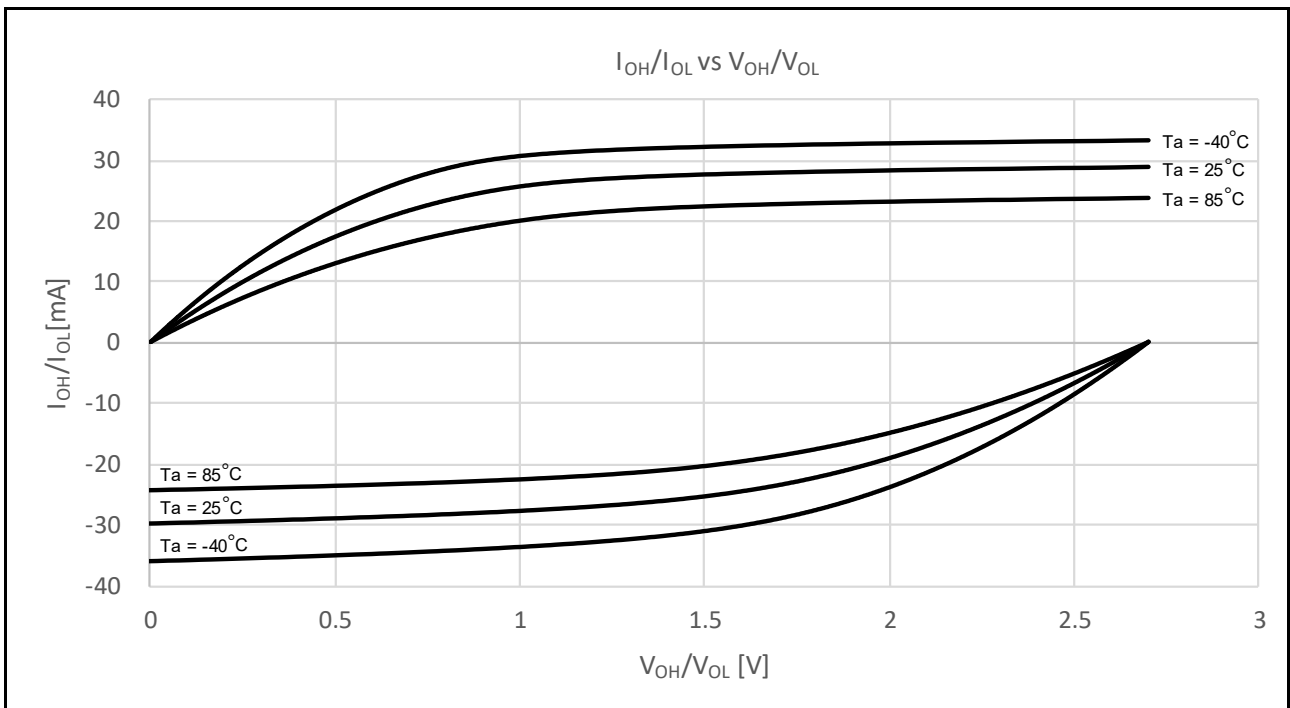

Figure 2.8 V_{OH}/V_{OL} and I_{OH}/I_{OL} temperature characteristics at $V_{CC} = 2.7$ V when middle drive output is selected (reference data)

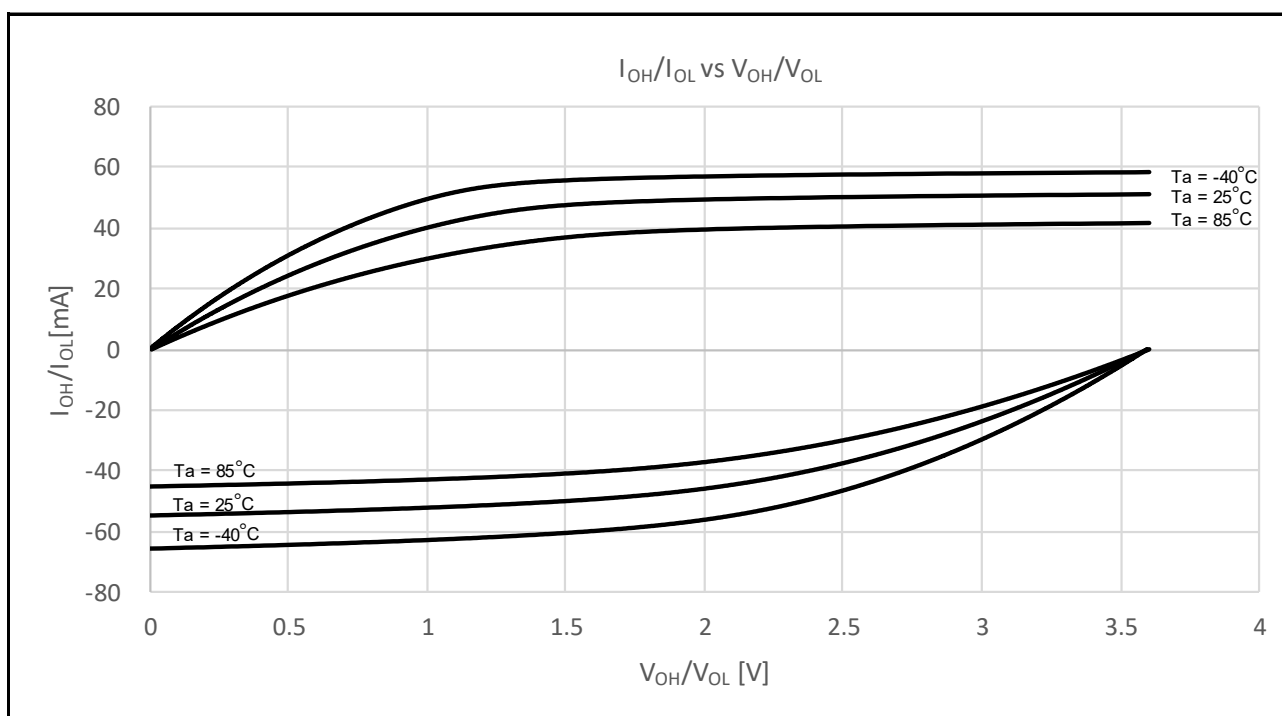

Figure 2.9 V_{OH}/V_{OL} and I_{OH}/I_{OL} temperature characteristics at $V_{CC} = 3.6\text{ V}$ when middle drive output is selected (reference data)

2.2.7 P409 I/O Pin Output Characteristics of Middle Drive Capacity

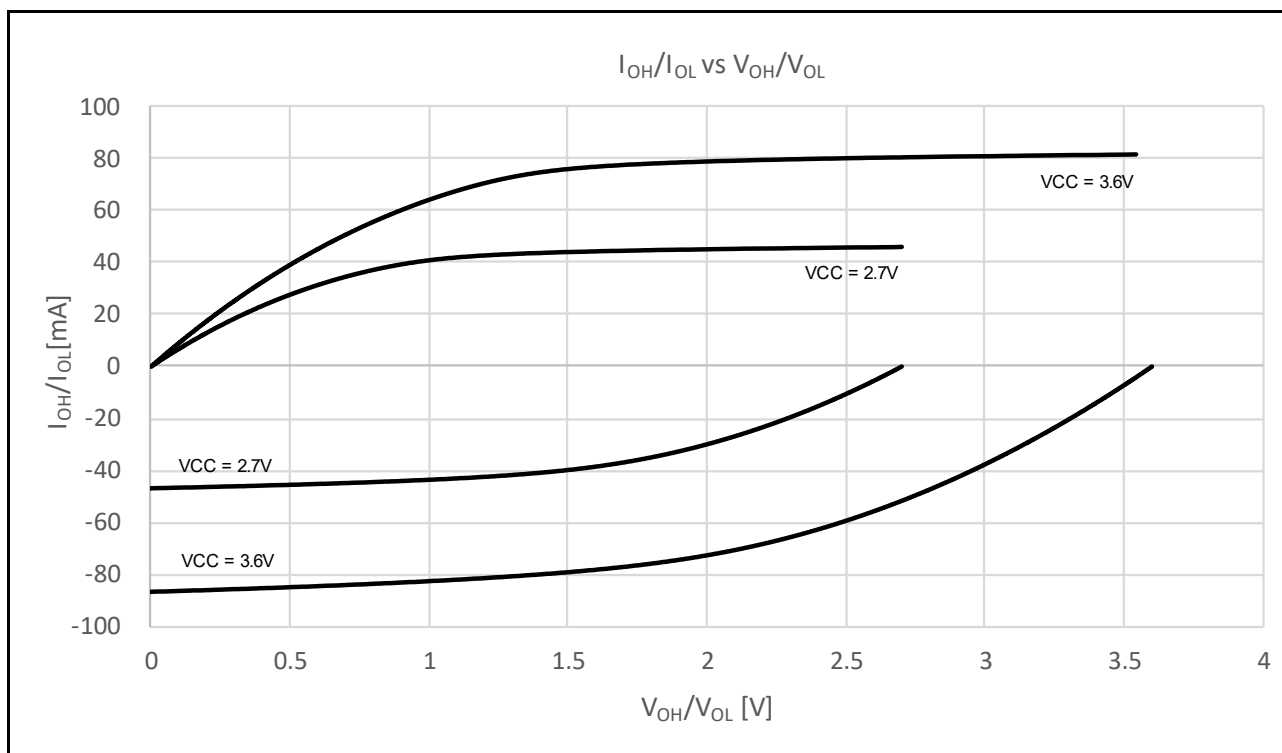

Figure 2.10 V_{OH}/V_{OL} and I_{OH}/I_{OL} voltage characteristics at $T_a = 25^\circ\text{C}$ when middle drive output is selected (reference data)

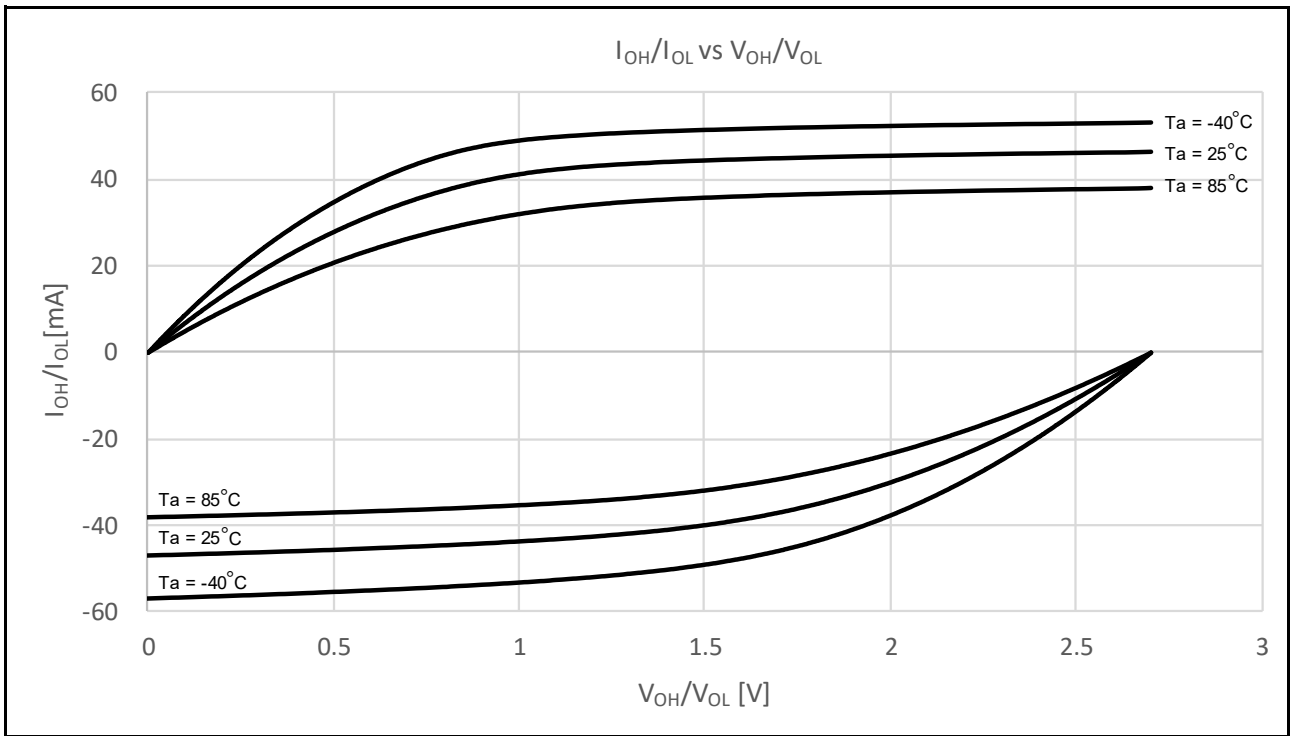

Figure 2.11 V_{OH}/V_{OL} and I_{OH}/I_{OL} temperature characteristics at $V_{CC} = 2.7$ V when middle drive output is selected (reference data)

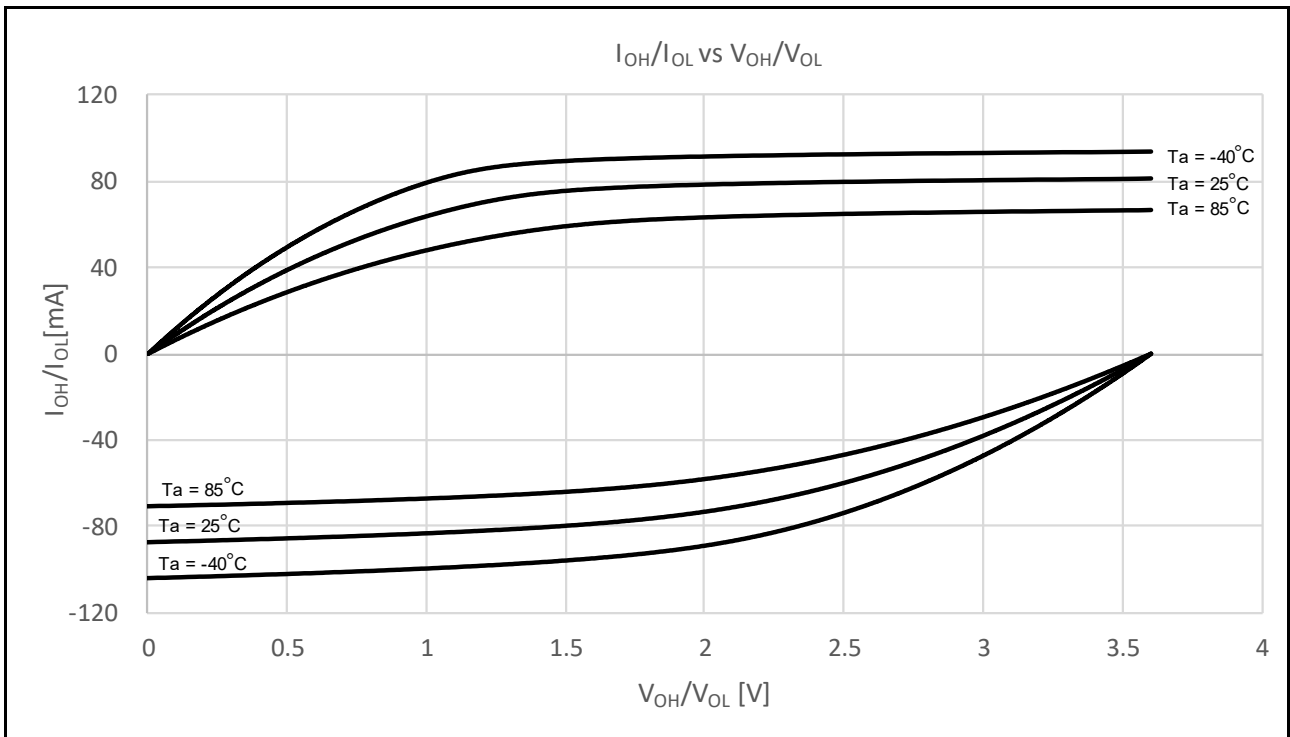

Figure 2.12 V_{OH}/V_{OL} and I_{OH}/I_{OL} temperature characteristics at $V_{CC} = 3.6$ V when middle drive output is selected (reference data)

2.2.8 IIC I/O Pin Output Characteristics

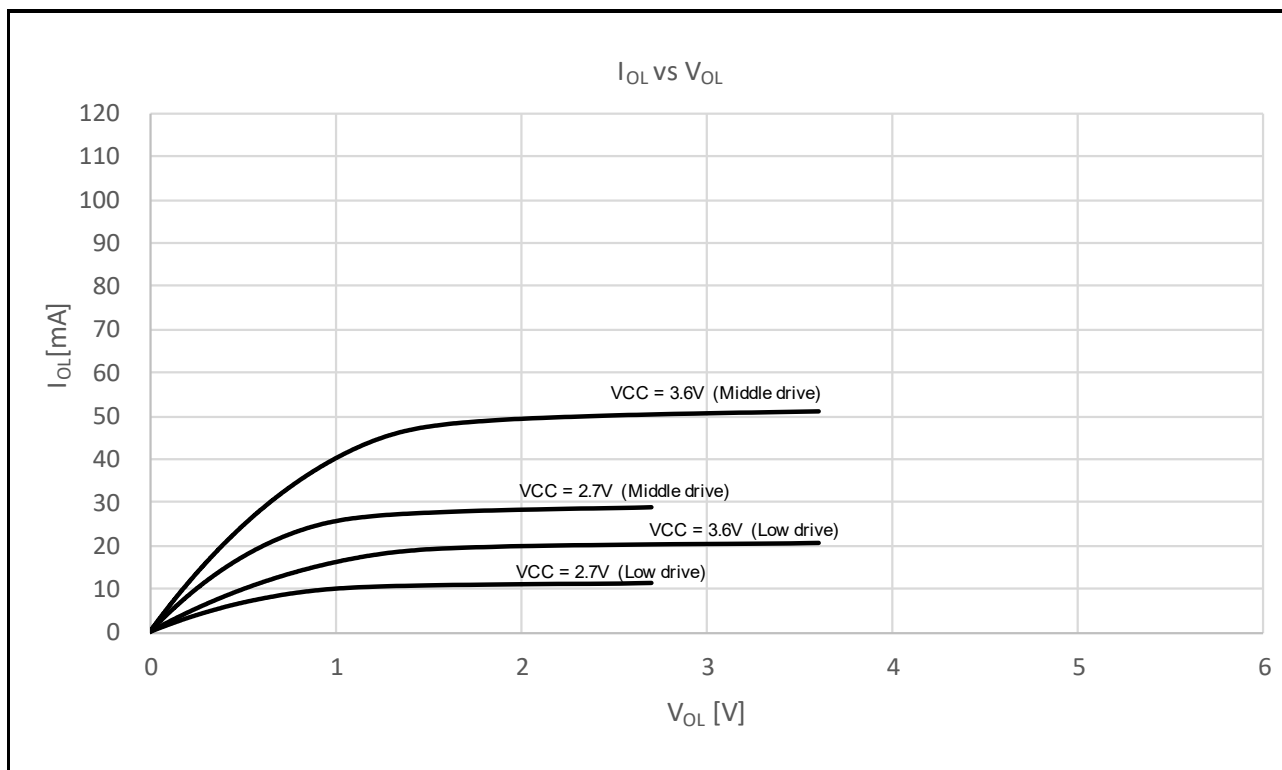

Figure 2.13 V_{OH}/V_{OL} and I_{OH}/I_{OL} voltage characteristics at $T_a = 25^\circ\text{C}$

2.2.9 Operating and Standby Current

Table 2.11 Operating and standby current (1) (1 of 2)

Conditions: VCC = AVCC0 = 1.8 to 3.6 V

Parameter					Symbol	Typ*10	Max	Unit	Test conditions		
Supply current*1	High-speed mode*2	Normal mode	All peripheral clock disabled, while (1) code executing from flash*5	ICLK = 48 MHz	I _{CC}	8.4	-	mA	*7		
				ICLK = 32 MHz		5.9	-				
				ICLK = 16 MHz		3.5	-				
				ICLK = 8 MHz		2.3	-				
			All peripheral clock disabled, CoreMark code executing from flash*5	ICLK = 48 MHz		17.9	-				
				ICLK = 32 MHz		12.4	-				
				ICLK = 16 MHz		7.0	-				
				ICLK = 8 MHz		4.3	-				
			All peripheral clock enabled, while (1) code executing from flash*5	ICLK = 48 MHz		21.2	-			*9	
				ICLK = 32 MHz		16.0	-			*8	
				ICLK = 16 MHz		8.8	-				
				ICLK = 8 MHz		5.1	-				
		All peripheral clock enabled, code executing from SRAM*5	ICLK = 48 MHz	-	56.0	*9					
			Sleep mode								
		Middle-speed mode*2	Normal mode	All peripheral clock disabled, while (1) code executing from flash*5	ICLK = 48 MHz	I _{CC}	3.7	-	mA	*7	
					ICLK = 32 MHz		2.7	-			
					ICLK = 16 MHz		2.0	-			
					ICLK = 8 MHz		1.5	-			
	All peripheral clock disabled, CoreMark code executing from flash*5			ICLK = 48 MHz	16.4		-	*9			
				ICLK = 32 MHz	12.7		-	*8			
				ICLK = 16 MHz	7.2		-				
				ICLK = 8 MHz	4.3		-				
	All peripheral clock enabled, while (1) code executing from flash*5			ICLK = 12 MHz	-		23.0				
				ICLK = 8 MHz	-		23.0				
ICLK = 1 MHz				-	23.0						
ICLK = 1 MHz				-	23.0						
All peripheral clock enabled, code executing from SRAM*5	ICLK = 12 MHz		-	23.0							
	ICLK = 1 MHz		-	23.0							
Increase during BGO operation*6					2.5	-	-				
Sleep mode	All peripheral clock disabled*5		ICLK = 12 MHz	ICLK = 12 MHz	I _{CC}	1.4	-	mA	*7		
				ICLK = 8 MHz		1.3	-				
				ICLK = 1 MHz		0.9	-				
		All peripheral clock enabled*5	ICLK = 12 MHz	5.3		-	*8				
			ICLK = 8 MHz	4.0		-					
			ICLK = 1 MHz	1.5		-					
	Increase during BGO operation*6						2.5			-	-

Table 2.11 Operating and standby current (1) (2 of 2)

Conditions: VCC = AVCC0 = 1.8 to 3.6 V

Parameter				Symbol	Typ*10	Max	Unit	Test conditions	
Supply current*1	Low-speed mode*3	Normal mode	All peripheral clock disabled, while (1) code executing from flash*5	ICLK = 1 MHz	I _{CC}	0.4	-	mA	*7
			All peripheral clock disabled, CoreMark code executing from flash*5	ICLK = 1 MHz		0.6	-		
			All peripheral clock enabled, while (1) code executing from flash*5	ICLK = 1 MHz		1.1	-		*8
			All peripheral clock enabled, code executing from SRAM*5	ICLK = 1 MHz		-	2.5		
		Sleep mode	All peripheral clock disabled*5	ICLK = 1 MHz		0.3	-	*7	
			All peripheral clock enabled*5	ICLK = 1 MHz		1.0	-	*8	
	Low-voltage mode*3	Normal mode	All peripheral clock disabled, while (1) code executing from flash*5	ICLK = 4 MHz	I _{CC}	1.8	-	mA	*7
			All peripheral clock disabled, CoreMark code executing from flash*5	ICLK = 4 MHz		3.0	-		
			All peripheral clock enabled, while (1) code executing from flash*5	ICLK = 4 MHz		3.3	-		*8
			All peripheral clock enabled, code executing from SRAM*5	ICLK = 4 MHz		-	9.0		
Sleep mode		All peripheral clock disabled*5	ICLK = 4 MHz	1.4		-	*7		
		All peripheral clock enabled*5	ICLK = 4 MHz	2.9		-	*8		
Subosc-speed mode*4	Normal mode	All peripheral clock disabled, while (1) code executing from flash*5	ICLK = 32.768 kHz	I _{CC}	9.3	-	μA	*8	
		All peripheral clock enabled, while (1) code executing from flash*5	ICLK = 32.768 kHz		17.2	-			
		All peripheral clock enabled, code executing from SRAM*5	ICLK = 32.768 kHz		-	106.0			
	Sleep mode	All peripheral clock disabled*5	ICLK = 32.768 kHz		6.0	-			
		All peripheral clock enabled*5	ICLK = 32.768 kHz		14.0	-			

- Note 1. Supply current values do not include output charge/discharge current from all pins. The values apply when internal pull-up MOSs are in the off state.
- Note 2. The clock source is HOCO.
- Note 3. The clock source is MOCO.
- Note 4. The clock source is the sub-clock oscillator.
- Note 5. This does not include BGO operation.
- Note 6. This is the increase for programming or erasure of the flash memory for data storage during program execution.
- Note 7. FCLK, PCLKA, PCLKB, PCLKC and PCLKD are set to divided by 64.
- Note 8. FCLK, PCLKA, PCLKB, PCLKC and PCLKD are the same frequency as that of ICLK.
- Note 9. FCLK and PCLKB are set to divided by 2 and PCLKA, PCLKC and PCLKD are the same frequency as that of ICLK.
- Note 10. VCC = 3.3 V.

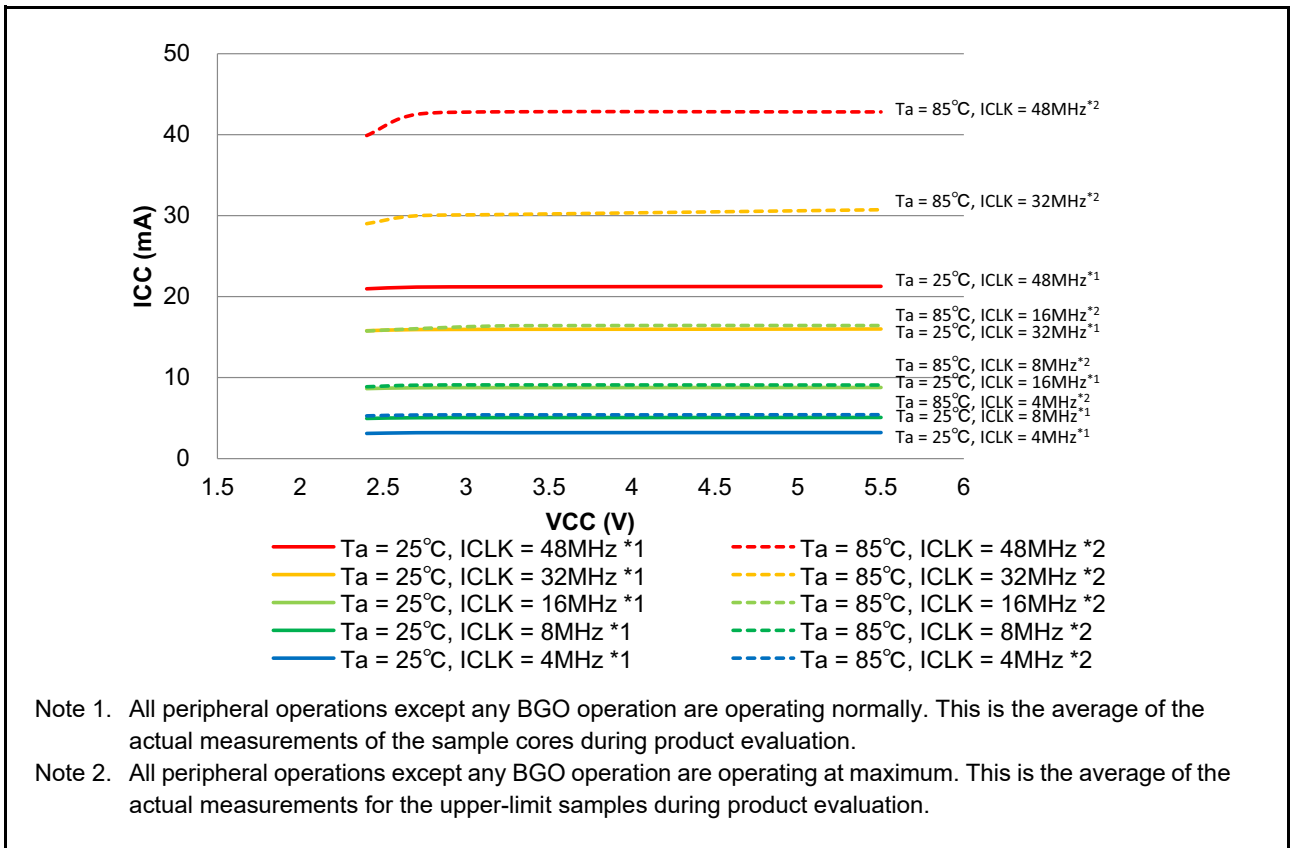

Figure 2.14 Voltage dependency in high-speed mode (reference data)

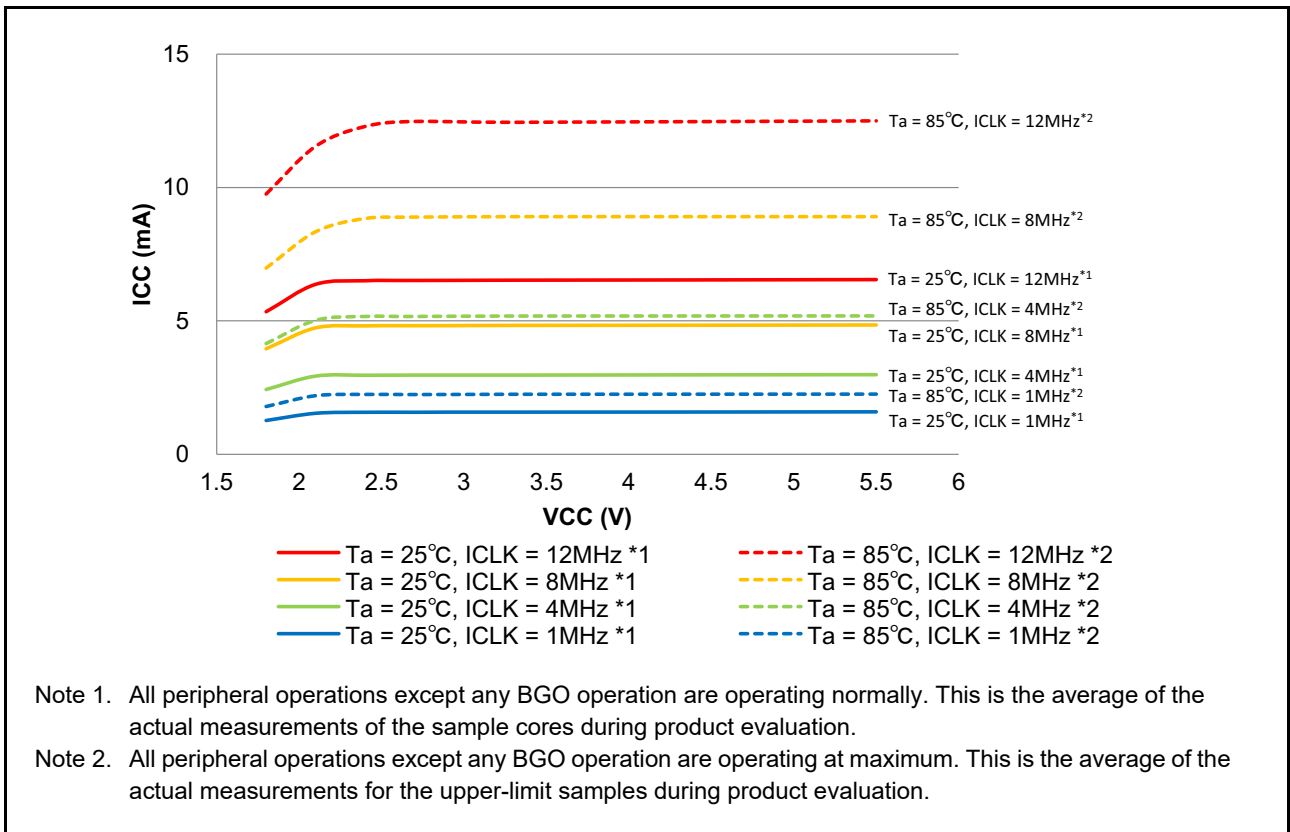

Figure 2.15 Voltage dependency in middle-speed mode (reference data)

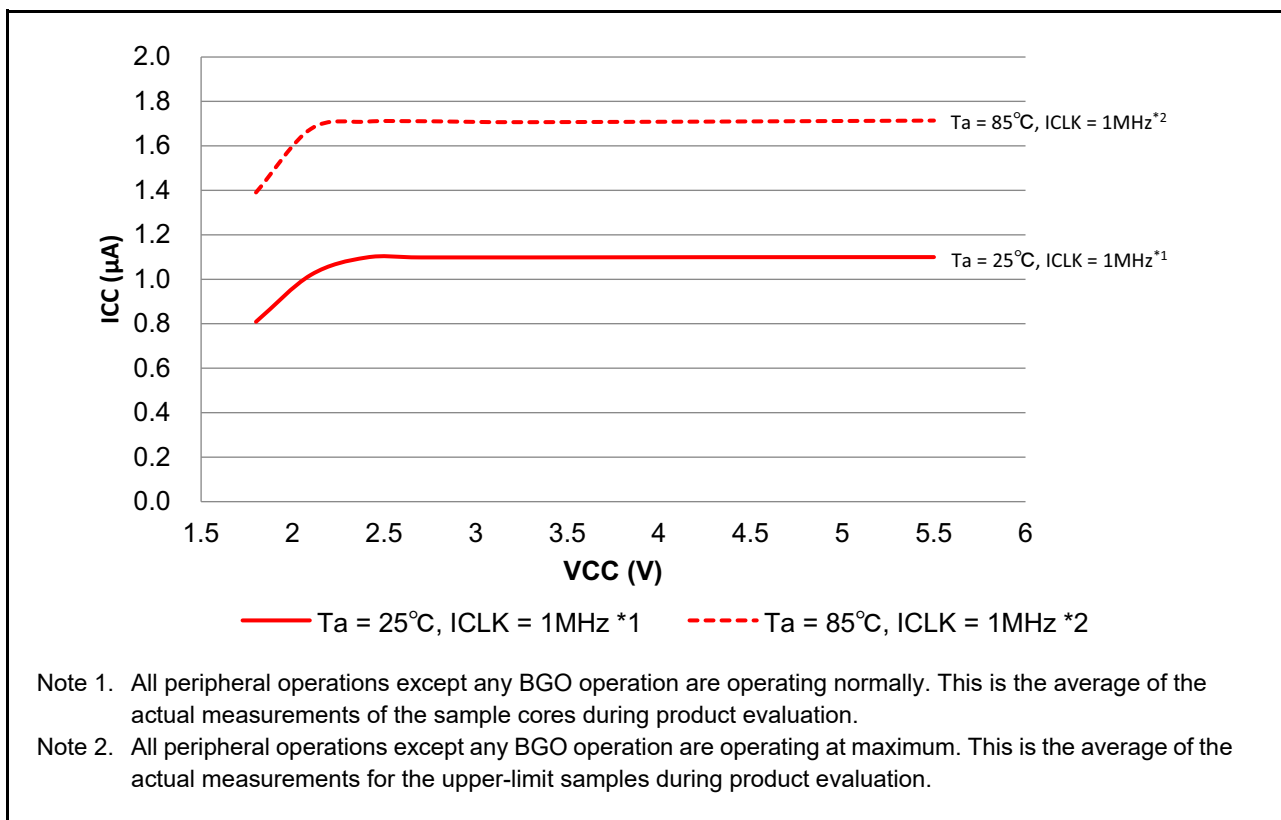

Figure 2.16 Voltage dependency in low-speed mode (reference data)

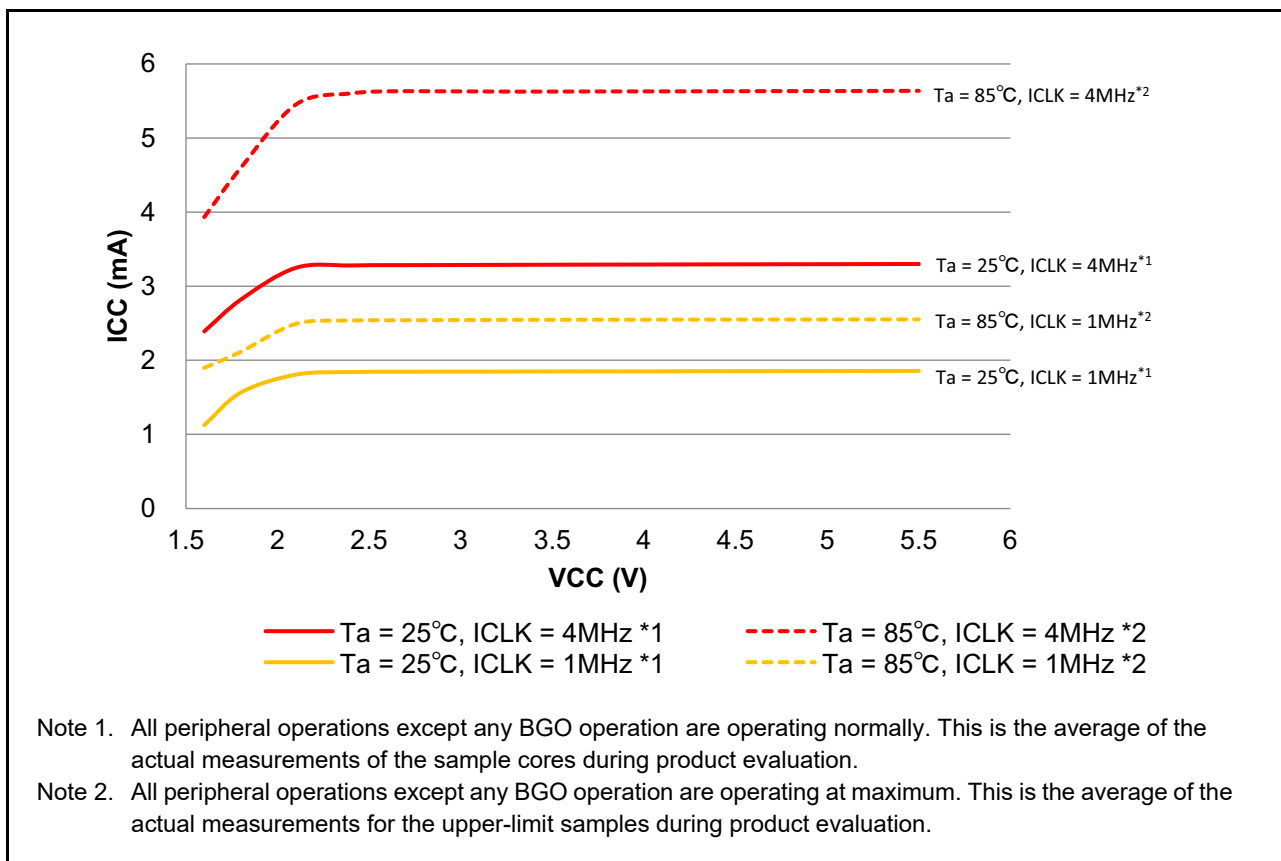

Figure 2.17 Voltage dependency in low-voltage mode (reference data)

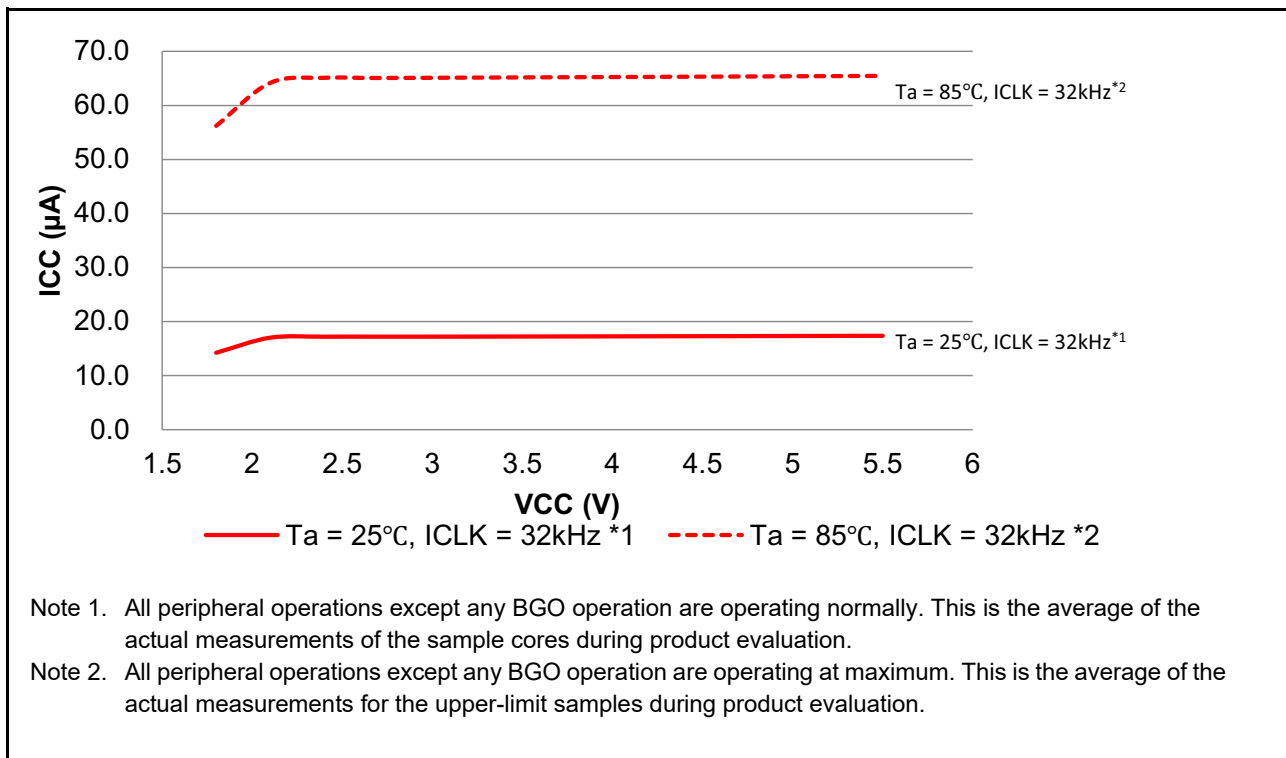

Figure 2.18 Voltage dependency in subosc-speed mode (reference data)

Table 2.12 Operating and standby current (2)

Conditions: VCC = AVCC0 = 1.8 to 3.6 V

Parameter		Symbol	Typ*4	Max	Unit	Test conditions	
Supply current*1	Software Standby mode*2	I _{CC}	T _a = 25°C	0.9	5.0	µA	PSMCR.PSMC[1:0] = 01b (48-KB SRAM on)
			T _a = 55°C	1.5	8.1		
			T _a = 85°C	3.6	22.1		
			T _a = 25°C	1.0	5.6		PSMCR.PSMC[1:0] = 00b (All SRAM on)
			T _a = 55°C	1.6	8.4		
			T _a = 85°C	4.3	26.7		
	Increment for RTC operation with low-speed on-chip oscillator*3			0.5	-		-
	Increment for RTC operation with sub-clock oscillator*3			0.4	-		SOMCR.SODRV[1:0] are 11b (Low power mode 3)
				1.2	-		SOMCR.SODRV[1:0] are 00b (Normal mode)

Note 1. Supply current values do not include output charge/discharge current from all pins. The values apply when internal pull-up MOSs are in the off state.

Note 2. The IWDT and LVD are not operating.

Note 3. Includes the current of sub-oscillation circuit or low-speed on-chip oscillator.

Note 4. VCC = 3.3 V.

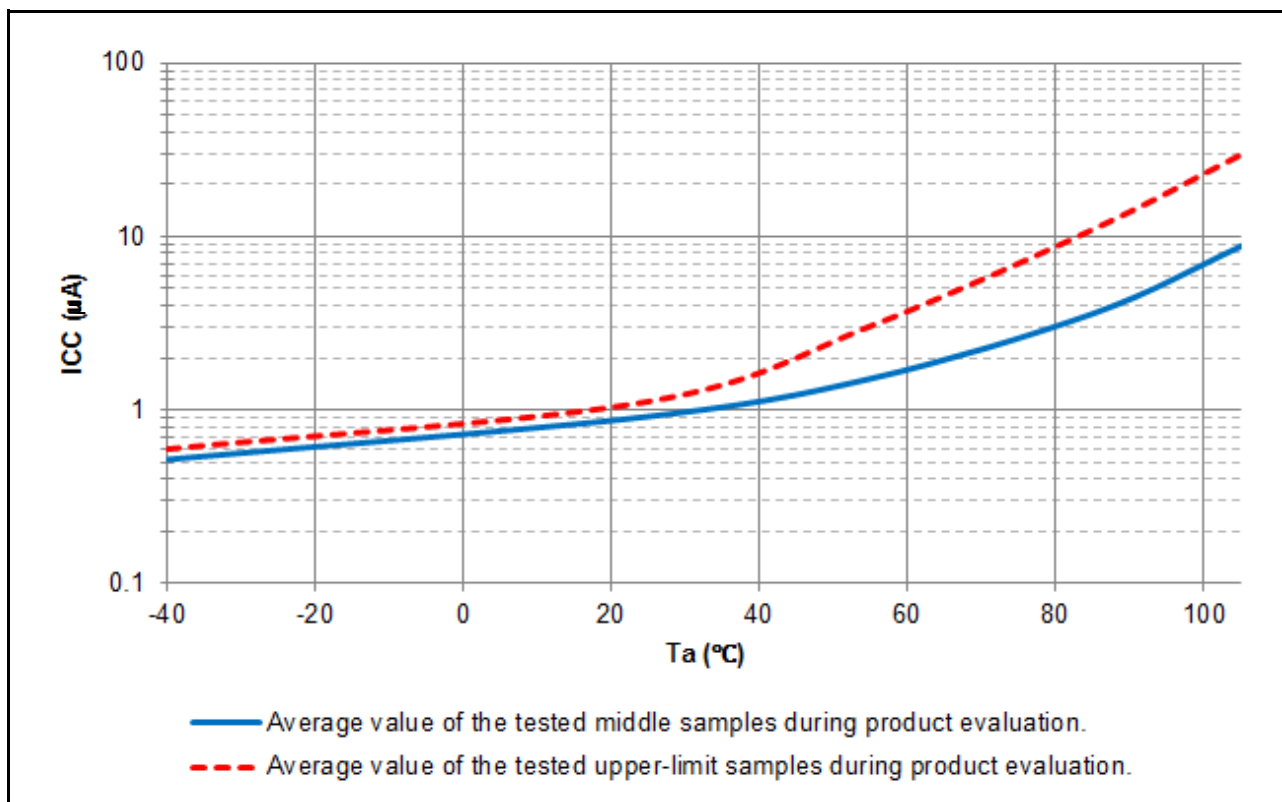

Figure 2.19 Temperature dependency in Software Standby mode 48-KB SRAM on (reference data)

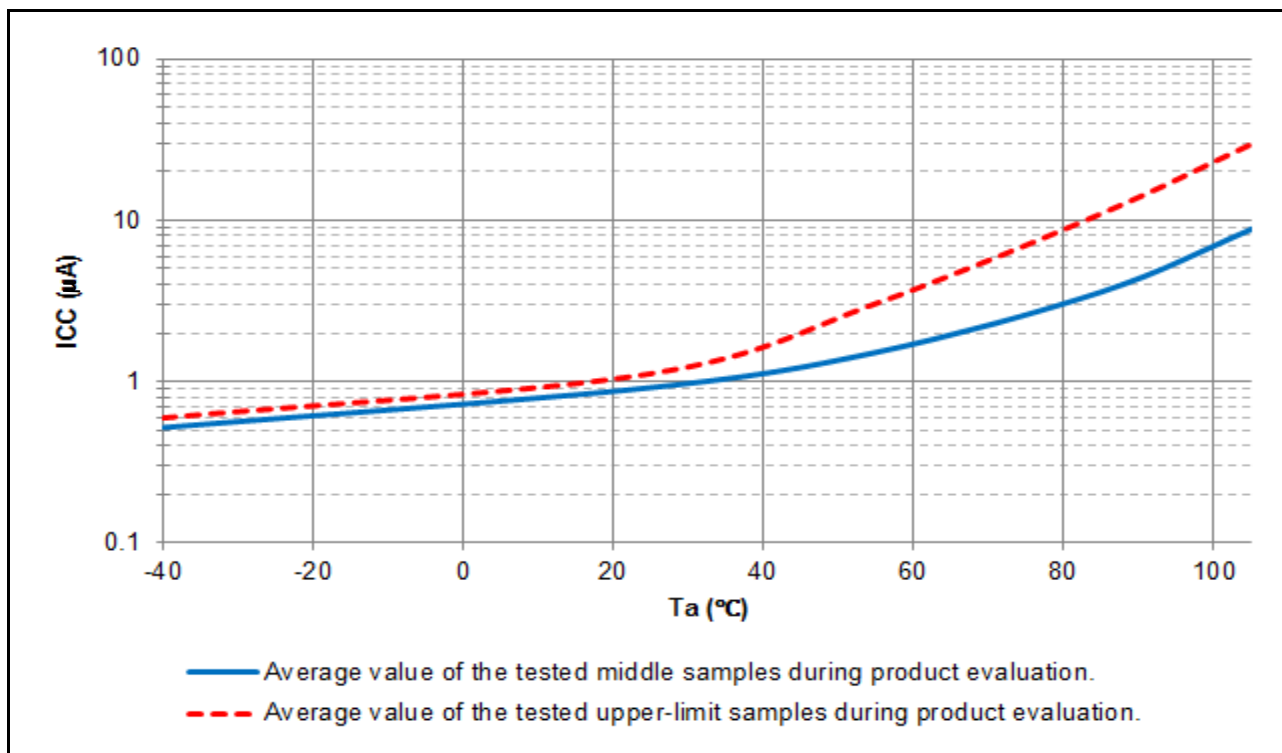

Figure 2.20 Temperature dependency in Software Standby mode all SRAM on (reference data)

Table 2.13 Operating and standby current (3)

Conditions: VCC = AVCC0 = 0V, VBATT = 1.8 to 3.6 V, VSS = AVSS0 = 0V

Parameter	Symbol	Typ	Max	Unit	Test conditions		
Supply current*1 RTC operation when VCC is off	I _{CC}	T _a = 25°C	0.8	-	μA	VBATT = 2.0 V SOMCR.SORDRV[1:0] = 11b (Low power mode 3)	
		T _a = 55°C	0.9	-			
		T _a = 85°C	1.1	-			
		T _a = 25°C	0.9	-			VBATT = 3.3 V SOMCR.SORDRV[1:0] = 11b (Low power mode 3)
		T _a = 55°C	1.0	-			
		T _a = 85°C	1.2	-			
		T _a = 25°C	1.6	-		VBATT = 2.0 V SOMCR.SORDRV[1:0] = 00b (Normal mode)	
		T _a = 55°C	1.8	-			
		T _a = 85°C	2.1	-			
		T _a = 25°C	1.7	-		VBATT = 3.3 V SOMCR.SORDRV[1:0] = 00b (Normal mode)	
		T _a = 55°C	1.9	-			
		T _a = 85°C	2.2	-			

Note 1. Supply current values do not include output charge/discharge current from all pins. The values apply when internal pull-up MOSs are in the off state.

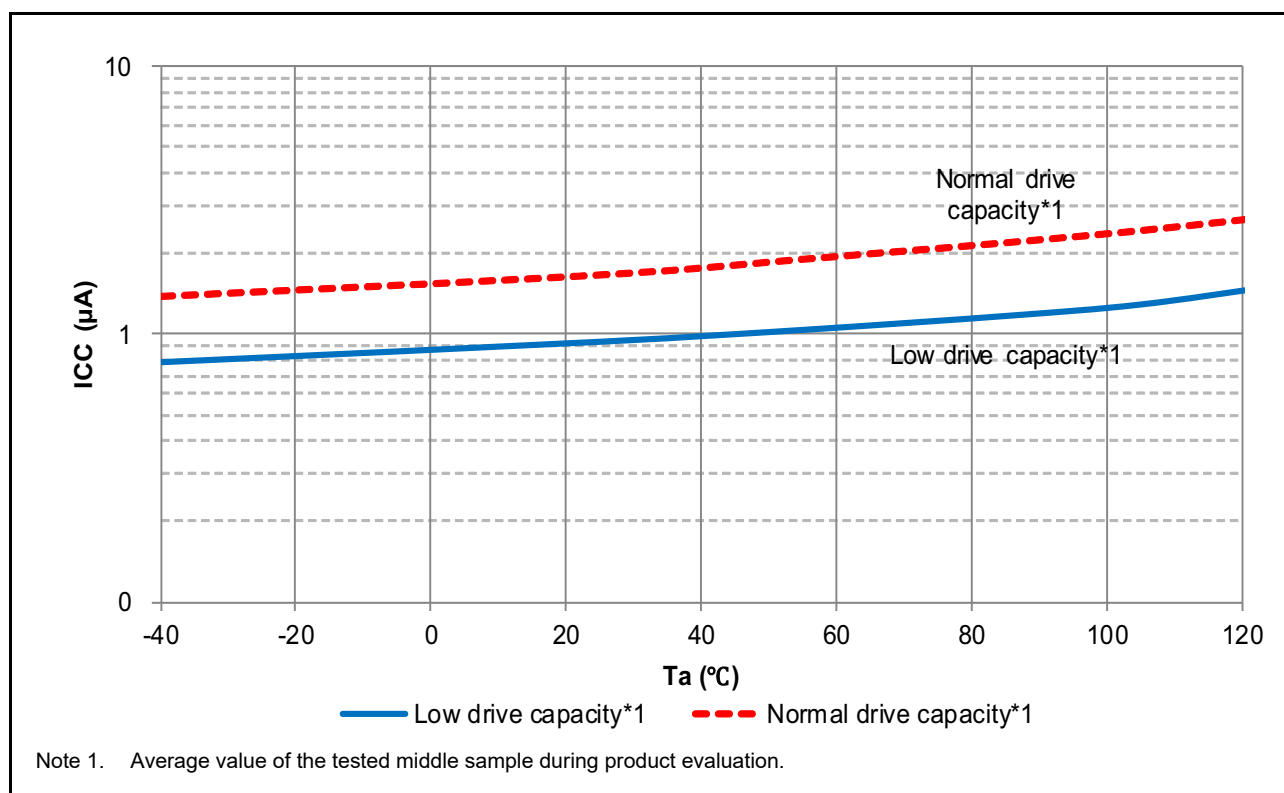

Figure 2.21 Temperature dependency of RTC operation with VCC off (reference data)

Table 2.14 Operating and standby current (4)

Conditions: VCC = AVCC0 = 1.8 to 3.6 V, VREFH0 = 2.7 V to AVCC0

Parameter		Symbol	Min	Typ	Max	Unit	Test conditions	
Analog power supply current	During A/D conversion (at high-speed conversion)	I _{AVCC}	-	-	3.0	mA	-	
	During A/D conversion (at low power conversion)		-	-	1.0	mA	-	
	During D/A conversion (per channel)*1		-	0.4	0.8	mA	-	
	Waiting for A/D and D/A conversion (all units)*6		-	-	1.0	μA	-	
Reference power supply current	During A/D conversion	I _{REFH0}	-	-	150	μA	-	
	Waiting for A/D conversion (all units)		-	-	60	nA	-	
	During D/A conversion	I _{REFH}	-	50	100	μA	-	
	Waiting for D/A conversion (all units)		-	-	100	μA	-	
Temperature sensor		I _{TNS}	-	75	-	μA	-	
Low-Power Analog Comparator operating current	Window mode	I _{CMP} LP	-	15	-	μA	-	
	Comparator High-speed mode		-	10	-	μA	-	
	Comparator Low-speed mode		-	2	-	μA	-	
	Comparator Low-speed mode using DAC8		-	820	-	μA	-	
Operational Amplifier operating current	Low power mode	I _{AMP}	1 unit operating	-	2.5	4.0	μA	-
	High speed mode		1 unit operating	-	140	220	μA	-
LCD operating current	External resistance division method f _{LCD} = f _{SUB} = 128 Hz, 1/3 bias, and 4-time slice		I _{LCD1} *5	-	0.34	-	μA	-
USB operating current	During USB communication operation under the following settings and conditions: • Host controller operation is set to full-speed mode Bulk OUT transfer (64 bytes) × 1, bulk IN transfer (64 bytes) × 1 • Connect peripheral devices via a 1-meter USB cable from the USB port.		I _{USBH} *2	-	4.3 (VCC) 0.9 (VCC_USB)*4	-	mA	-
	During USB communication operation under the following settings and conditions: • Device controller operation is set to full-speed mode Bulk OUT transfer (64 bytes) × 1, bulk IN transfer (64 bytes) × 1 • Connect the host device via a 1-meter USB cable from the USB port.		I _{USBF} *2	-	3.6 (VCC) 1.1 (VCC_USB)*4	-	mA	-
	During suspended state under the following setting and conditions: • Device controller operation is set to full-speed mode (pull up the USB_DP pin) • Software standby mode • Connect the host device via a 1-meter USB cable from the USB port.		I _{SUSP} *3	-	0.35 (VCC) 170 (VCC_USB)*4	-	μA	-

Note 1. The reference power supply current is included in the power supply current value for D/A conversion.

Note 2. Current consumed only by the USBFS.

Note 3. Includes the current supplied from the pull-up resistor of the USB_DP pin to the pull-down resistor of the host device, in addition to the current consumed by the MCU during the suspended state.

Note 4. When VCC = VCC_USB = 3.3 V.

Note 5. Current flowing only to the LCD controller. Not including the current that flows through the LCD panel.

Note 6. When the MCU is in Software Standby mode or the MSTPCR.DMSTPD16 (ADC140 Module Stop bit) is in the module-stop state.

Table 2.15 Operating and standby current (5)

Conditions: VCC = VCC_RF = AVCC_RF = 3.3 V, VSS = VSS_RF = 0 V, Ta = +25°C

Parameter		Symbol	Min	Typ		Max	Unit	Test conditions
				Transmit output power				
				0 dBm	4 dBm			
BLE operating current (When DC-DC converter is selected)	Transmit mode, 2 Mbps	Idd_tx	-	4.5	8.7	-	mA	-
	Transmit mode, 1 Mbps		-			-		
	Transmit mode, 500 kbps		-			-		
	Transmit mode, 125 kbps		-			-		
	Receive mode, 2 Mbps Prf = -67 dBm	Idd_rx	-	3.3	3.5	-	mA	-
	Receive mode, 1 Mbps Prf = -67 dBm		-			-		
	Receive mode, 500 kbps Prf = -72 dBm		-			-		
	Receive mode, 125 kbps Prf = -79 dBm		-			-		
	Idle mode	Idd_idle	-	0.5		-	mA	-
	Deep sleep mode	Idd_slp	-	1.5		-		μA
Power down mode	Idd_down	-	0.1		-	μA		-
BLE operating current (When linear regulator is selected)	Transmit mode, 2 Mbps	Idd_tx	-	10.2	18.1	-	mA	-
	Transmit mode, 1 Mbps		-			-		
	Transmit mode, 500 kbps		-			-		
	Transmit mode, 125 kbps		-			-		
	Receive mode, 2M bps Prf = -67 dBm	Idd_rx	-	6.9		-	mA	-
	Receive mode, 1 Mbps Prf = -67 dBm		-	6.9		-		-
	Receive mode, 500 kbps Prf = -72 dBm		-	6.9		-		-
	Receive mode, 125 kbps Prf = -79 dBm		-	7.1		-		-
	Idd_idle	Idd_idle	-	0.7		-	mA	-
	Idd_slp	Idd_slp	-	1.5		-		μA
Idd_down	Idd_down	-	0.1		-	μA		-

2.2.10 VCC Rise and Fall Gradient and Ripple Frequency

Table 2.16 Rise and fall gradient characteristics

Conditions: VCC = AVCC0 = 0 to 3.6 V

Parameter		Symbol	Min	Typ	Max	Unit	Test conditions
Power-on VCC rising gradient	Voltage monitor 0 reset disabled at startup (normal startup)	SrVCC	0.02	-	2	ms/V	-
	Voltage monitor 0 reset enabled at startup*1		0.02	-	-		
	SCI/USB Boot mode*2		0.02	-	2		

Note 1. When OFS1.LVDAS = 0.

Note 2. At boot mode, the reset from voltage monitor 0 is disabled regardless of the value of the OFS1.LVDAS bit.

Table 2.17 Rising and falling gradient and ripple frequency characteristics

Conditions: VCC = AVCC0 = VCC_USB = 1.8 to 3.6 V

The ripple voltage must meet the allowable ripple frequency $f_r(VCC)$ within the range between the VCC upper limit (3.6 V) and lower limit (1.8 V).

When VCC change exceeds VCC $\pm 10\%$, the allowable voltage change rising/falling gradient dt/dVCC must be met.

Parameter	Symbol	Min	Typ	Max	Unit	Test conditions
Allowable ripple frequency	$f_r(VCC)$	-	-	10	kHz	Figure 2.22 $V_r(VCC) \leq VCC \times 0.2$
		-	-	1	MHz	Figure 2.22 $V_r(VCC) \leq VCC \times 0.08$
		-	-	10	MHz	Figure 2.22 $V_r(VCC) \leq VCC \times 0.06$
Allowable voltage change rising and falling gradient	dt/dVCC	1.0	-	-	ms/V	When VCC change exceeds VCC $\pm 10\%$

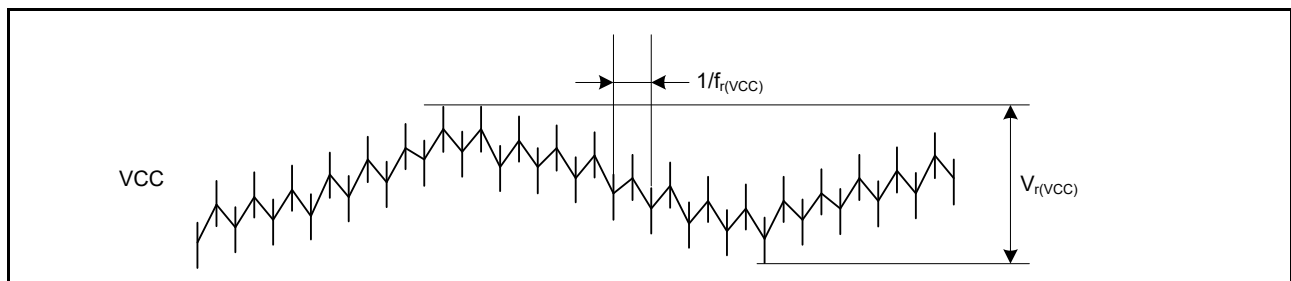

Figure 2.22 Ripple waveform

2.3 AC Characteristics

2.3.1 Frequency

Table 2.18 Operation frequency value in high-speed operating mode

Conditions: VCC = AVCC0 = 2.4 to 3.6 V

Parameter			Symbol	Min	Typ	Max*5	Unit
Operation frequency	System clock (ICLK)*4	2.7 to 3.6 V	f	0.032768	-	48	MHz
		2.4 to 2.7 V		0.032768	-	16	
	FlashIF clock (FCLK)*1, *2, *4	2.7 to 3.6 V		0.032768	-	32	
		2.4 to 2.7 V		0.032768	-	16	
	Peripheral module clock (PCLKA)*4	2.7 to 3.6 V		-	-	48	
		2.4 to 2.7 V		-	-	16	
	Peripheral module clock (PCLKB)*4	2.7 to 3.6 V		-	-	32	
		2.4 to 2.7 V		-	-	16	
	Peripheral module clock (PCLKC)*3, *4	2.7 to 3.6 V		-	-	64	
		2.4 to 2.7 V		-	-	16	
	Peripheral module clock (PCLKD)*4	2.7 to 3.6 V		-	-	64	
		2.4 to 2.7 V		-	-	16	

- Note 1. The lower-limit frequency of FCLK is 1 MHz while programming or erasing the flash memory. When using FCLK for programming or erasing the flash memory at below 4 MHz, the frequency can be set to 1 MHz, 2 MHz, or 3 MHz. A non-integer frequency such as 1.5 MHz cannot be set.
- Note 2. The frequency accuracy of FCLK must be $\pm 3.5\%$ while programming or erasing the flash memory. Confirm the frequency accuracy of the clock source.
- Note 3. The lower-limit frequency of PCLKC is 4 MHz at 2.4 V or above and 1 MHz at below 2.4 V when the 14-bit A/D converter is in use.
- Note 4. See section 9, Clock Generation Circuit in User's Manual for the relationship of frequencies between ICLK, PCLKA, PCLKB, PCLKC, PCLKD, and FCLK.
- Note 5. The maximum value of operation frequency does not include the internal oscillator errors. The operation can be guaranteed with the errors of the internal oscillator. For details on the range for guaranteed operation, see [Table 2.23, Clock timing](#).

Table 2.19 Operation frequency value in Middle-speed mode

Conditions: VCC = AVCC0 = 1.8 to 3.6 V

Parameter			Symbol	Min	Typ	Max*5	Unit
Operation frequency	System clock (ICLK)*4	2.7 to 3.6 V	f	0.032768	-	12	MHz
		2.4 to 2.7 V		0.032768	-	12	
		1.8 to 2.4 V		0.032768	-	8	
	FlashIF clock (FCLK)*1, *2, *4	2.7 to 3.6 V		0.032768	-	12	
		2.4 to 2.7 V		0.032768	-	12	
		1.8 to 2.4 V		0.032768	-	8	
	Peripheral module clock (PCLKA)*4	2.7 to 3.6 V		-	-	12	
		2.4 to 2.7 V		-	-	12	
		1.8 to 2.4 V		-	-	8	
	Peripheral module clock (PCLKB)*4	2.7 to 3.6 V		-	-	12	
		2.4 to 2.7 V		-	-	12	
		1.8 to 2.4 V		-	-	8	
	Peripheral module clock (PCLKC)*3, *4	2.7 to 3.6 V		-	-	12	
		2.4 to 2.7 V		-	-	12	
		1.8 to 2.4 V		-	-	8	
	Peripheral module clock (PCLKD)*4	2.7 to 3.6 V		-	-	12	
		2.4 to 2.7 V		-	-	12	
		1.8 to 2.4 V		-	-	8	

- Note 1. The lower-limit frequency of FCLK is 1 MHz while programming or erasing the flash memory. When using FCLK for programming or erasing the flash memory at below 4 MHz, the frequency can be set to 1 MHz, 2 MHz, or 3 MHz. A non-integer frequency such as 1.5 MHz cannot be set.
- Note 2. The frequency accuracy of FCLK must be $\pm 3.5\%$ while programming or erasing the flash memory. Confirm the frequency accuracy of the clock source.
- Note 3. The lower-limit frequency of PCLKC is 4 MHz at 2.4 V or above and 1 MHz at below 2.4 V when the 14-bit A/D converter is in use.
- Note 4. See section 9, Clock Generation Circuit in User's Manual for the relationship of frequencies between ICLK, PCLKA, PCLKB, PCLKC, PCLKD, and FCLK.
- Note 5. The maximum value of operation frequency does not include errors of the internal oscillator. The operation can be guaranteed with the errors of the internal oscillator. For details on the range for guaranteed operation, see [Table 2.23, Clock timing](#).

Table 2.20 Operation frequency value in Low-speed mode

Conditions: VCC = AVCC0 = 1.8 to 3.6 V

Parameter		Symbol	Min	Typ	Max*4	Unit	
Operation frequency	System clock (ICLK)*3	f	1.8 to 3.6 V	0.032768	-	1	MHz
	FlashIF clock (FCLK)*1, *3		1.8 to 3.6 V	0.032768	-	1	
	Peripheral module clock (PCLKA)*3		1.8 to 3.6 V	-	-	1	
	Peripheral module clock (PCLKB)*3		1.8 to 3.6 V	-	-	1	
	Peripheral module clock (PCLKC)*2, *3		1.8 to 3.6 V	-	-	1	
	Peripheral module clock (PCLKD)*3		1.8 to 3.6 V	-	-	1	

- Note 1. The lower-limit frequency of FCLK is 1 MHz while programming or erasing the flash memory.
- Note 2. The lower-limit frequency of PCLKC is 1 MHz when the A/D converter is in use.
- Note 3. See section 9, Clock Generation Circuit in User's Manual for the relationship of frequencies between ICLK, PCLKA, PCLKB, PCLKC, PCLKD, and FCLK.
- Note 4. The maximum value of operation frequency does not include the internal oscillator errors. The operation can be guaranteed with the errors of the internal oscillator. For details on the range for guaranteed operation, see [Table 2.23, Clock timing](#).

Table 2.21 Operation frequency value in low-voltage mode

Conditions: VCC = AVCC0 = 1.8 to 3.6 V

Parameter		Symbol	Min	Typ	Max*5	Unit	
Operation frequency	System clock (ICLK)*4	f	1.8 to 3.6 V	0.032768	-	4	MHz
	FlashIF clock (FCLK)*1, *2, *4		1.8 to 3.6 V	0.032768	-	4	
	Peripheral module clock (PCLKA)*4		1.8 to 3.6 V	-	-	4	
	Peripheral module clock (PCLKB)*4		1.8 to 3.6 V	-	-	4	
	Peripheral module clock (PCLKC)*3, *4		1.8 to 3.6 V	-	-	4	
	Peripheral module clock (PCLKD)*4		1.8 to 3.6 V	-	-	4	

- Note 1. The lower-limit frequency of FCLK is 1 MHz while programming or erasing the flash memory. When using FCLK for programming or erasing the flash memory at below 4 MHz, the frequency can be set to 1 MHz, 2 MHz, or 3 MHz. A non-integer frequency such as 1.5 MHz cannot be set.
- Note 2. The frequency accuracy of FCLK must be $\pm 3.5\%$ while programming or erasing the flash memory. Confirm the frequency accuracy of the clock source.
- Note 3. The lower-limit frequency of PCLKC is 4 MHz at 2.4 V or above and 1 MHz at below 2.4 V when the 14-bit A/D converter is in use.
- Note 4. See section 9, Clock Generation Circuit in User's Manual for the relationship of frequencies between ICLK, PCLKA, PCLKB, PCLKC, PCLKD, and FCLK.
- Note 5. The maximum value of operation frequency does not include errors of the internal oscillator. The operation can be guaranteed with the errors of the internal oscillator. For details on the range for guaranteed operation, see [Table 2.23, Clock timing](#).

Table 2.22 Operation frequency value in Subosc-speed mode

Conditions: VCC = AVCC0 = 1.8 to 3.6 V

Parameter			Symbol	Min	Typ	Max	Unit
Operation frequency	System clock (ICLK)*3	1.8 to 3.6 V	f	27.8528	32.768	37.6832	kHz
	FlashIF clock (FCLK)*1, *3	1.8 to 3.6 V		27.8528	32.768	37.6832	
	Peripheral module clock (PCLKA)*3	1.8 to 3.6 V		-	-	37.6832	
	Peripheral module clock (PCLKB)*3	1.8 to 3.6 V		-	-	37.6832	
	Peripheral module clock (PCLKC)*2, *3	1.8 to 3.6 V		-	-	37.6832	
	Peripheral module clock (PCLKD)*3	1.8 to 3.6 V		-	-	37.6832	

Note 1. Programming and erasing the flash memory is not possible.

Note 2. The 14-bit A/D converter cannot be used.

Note 3. See section 9, Clock Generation Circuit in User's Manual for the relationship of frequencies between ICLK, PCLKA, PCLKB, PCLKC, PCLKD, FCLK, and BCLK.

2.3.2 Clock Timing

Table 2.23 Clock timing (1 of 2)

Parameter	Symbol	Min	Typ	Max	Unit	Test conditions
EXTAL external clock input cycle time	t_{Xcyc}	50	-	-	ns	Figure 2.23
EXTAL external clock input high pulse width	t_{XH}	20	-	-	ns	
EXTAL external clock input low pulse width	t_{XL}	20	-	-	ns	
EXTAL external clock rising time	t_{Xr}	-	-	5	ns	
EXTAL external clock falling time	t_{Xf}	-	-	5	ns	
EXTAL external clock input wait time*1	t_{EXWT}	0.3	-	-	μ s	-
EXTAL external clock input frequency	f_{EXTAL}	-	-	20	MHz	2.4 \leq VCC \leq 3.6
		-	-	8		1.8 \leq VCC < 2.4
Main clock oscillator oscillation frequency	f_{MAIN}	1	-	20	MHz	2.4 \leq VCC \leq 3.6
		1	-	8		1.8 \leq VCC < 2.4
Main clock oscillation stabilization wait time (crystal)*9	$t_{MAINOSCWT}$	-	-	-*9	ms	
LOCO clock oscillation frequency	f_{LOCO}	27.8528	32.768	37.6832	kHz	-
LOCO clock oscillation stabilization time	t_{LOCO}	-	-	100	μ s	Figure 2.24
IWDT-dedicated clock oscillation frequency	f_{ILOCO}	12.75	15	17.25	kHz	-
Bluetooth-dedicated clock oscillation frequency	f_{BLECK}	-	32	-	MHz	
Bluetooth-dedicated low-speed on-chip oscillator oscillation frequency	$f_{BLELOCO}$	-	32.768	-	kHz	
MOCO clock oscillation frequency	f_{MOCO}	6.8	8	9.2	MHz	-
MOCO clock oscillation stabilization time	t_{MOCO}	-	-	1	μ s	-
HOCO clock oscillation frequency	f_{HOCO24}	23.64	24	24.36	MHz	Ta = -40 to -20°C 1.8 \leq VCC \leq 3.6
		23.76	24	24.24		Ta = -20 to 85°C 1.8 \leq VCC \leq 3.6
	f_{HOCO32}	31.52	32	32.48		Ta = -40 to -20°C 1.8 \leq VCC \leq 3.6
		31.68	32	32.32		Ta = -20 to 85°C 1.8 \leq VCC \leq 3.6
	f_{HOCO48} *4	47.28	48	48.72		Ta = -40 to -20°C 1.8 \leq VCC \leq 3.6
		47.52	48	48.48		Ta = -20 to 85°C 1.8 \leq VCC \leq 3.6
	f_{HOCO64} *5	63.04	64	64.96		Ta = -40 to -20°C 2.4 \leq VCC \leq 3.6
		63.36	64	64.64		Ta = -20 to 85°C 2.4 \leq VCC \leq 3.6

Table 2.23 Clock timing (2 of 2)

Parameter		Symbol	Min	Typ	Max	Unit	Test conditions
HOCO clock oscillation stabilization time*6, *7	Except low-voltage mode	t _{HOCO24}	-	-	37.1	μs	Figure 2.25
		t _{HOCO32}	-	-	43.3		
		t _{HOCO48}	-	-	80.6		
	t _{HOCO64}	-	-	100.9			
	Low-Voltage mode	t _{HOCO24}	-	-	100.9		
		t _{HOCO32}	-	-			
		t _{HOCO48}	-	-			
		t _{HOCO64}	-	-			
PLL input frequency*2		f _{PLLIN}	4	-	12.5	MHz	-
PLL circuit oscillation frequency*2		f _{PLL}	24	-	64	MHz	-
PLL clock oscillation stabilization time*8		t _{PLL}	-	-	55.5	μs	Figure 2.27
PLL free-running oscillation frequency		f _{PLLFR}	-	8	-	MHz	-
Sub-clock oscillator oscillation frequency		f _{SUB}	-	32.768	-	kHz	-
Sub-clock oscillation stabilization time*3		t _{SUBOSC}	-	-	*3	s	Figure 2.28

- Note 1. Time until the clock can be used after the Main Clock Oscillator Stop bit (MOSCCR.MOSTP) is set to 0 (operating) when the external clock is stable.
- Note 2. The VCC range that the PLL can be used is 2.4 to 3.6 V.
- Note 3. After changing the setting of the SOSCCR.SOSTP bit so that the sub-clock oscillator operates, only start using the sub-clock oscillator after the sub-clock oscillation stabilization wait time elapses, that is greater than or equal to the value recommended by the oscillator manufacturer.
- Note 4. The 48-MHz HOCO can be used within a VCC range of 1.8 V to 3.6 V.
- Note 5. The 64-MHz HOCO can be used within a VCC range of 2.4 V to 3.6 V.
- Note 6. This is a characteristic when HOCOCCR.HCSTP bit is set to 0 (oscillation) in MOCO stop state. When HOCOCCR.HCSTP bit is set to 0 (oscillation) during MOCO oscillation, this specification is shortened by 1 μs.
- Note 7. Whether stabilization time has elapsed can be confirmed by OSCSF.HOCOSF.
- Note 8. This is a characteristic when PLLCR.PLLSTP bit is set to 0 (operation) in MOCO stop state. When PLLCR.PLLSTP bit is set to 0 (operation) during MOCO oscillation, this specification is shortened by 1 μs.
- Note 9. When setting up the main clock, ask the oscillator manufacturer for an oscillation evaluation and use the results as the recommended oscillation stabilization time. Set the MOSCWTCR register to a value equal to or greater than the recommended stabilization time. After changing the setting of the MOSCCR.MOSTP bit so that the main clock oscillator operates, read the OSCSF.MOSCSF flag to confirm that it is 1, then start using the main clock.

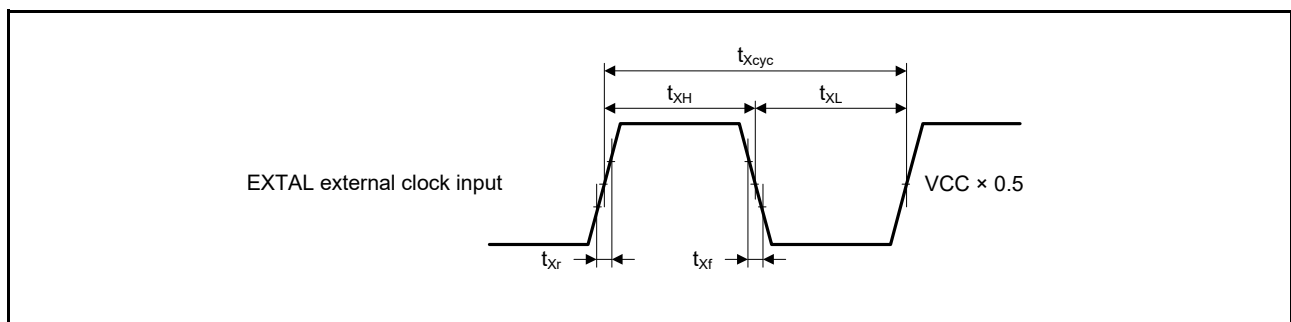

Figure 2.23 EXTAL external clock input timing

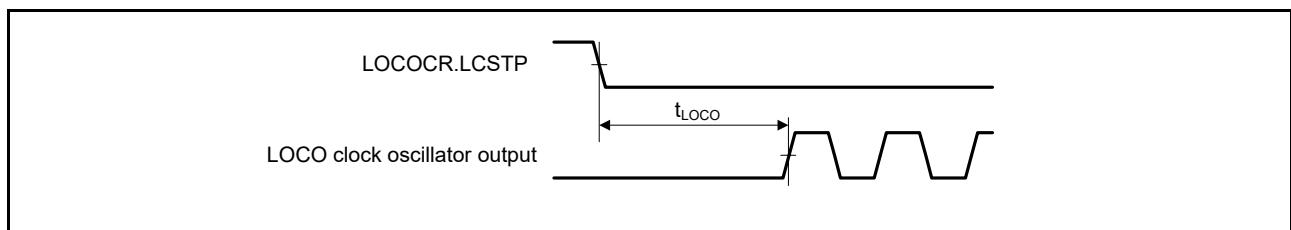

Figure 2.24 LOCO clock oscillation start timing

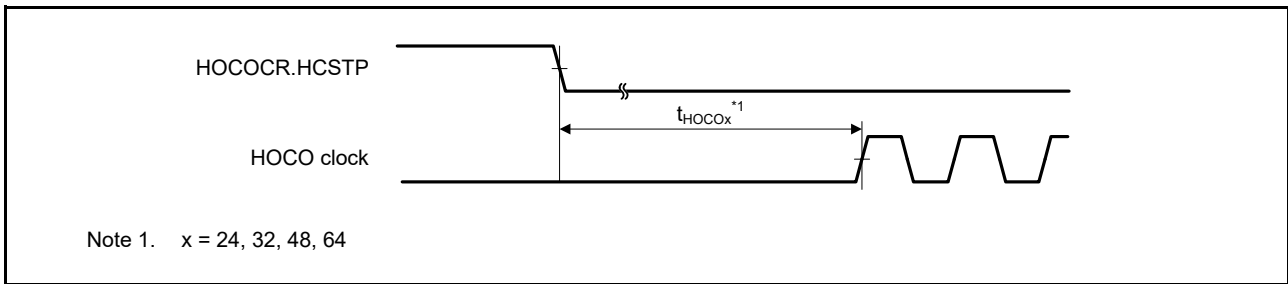

Figure 2.25 HOCO clock oscillation start timing (started by setting HOCOOCR.HCSTP bit)

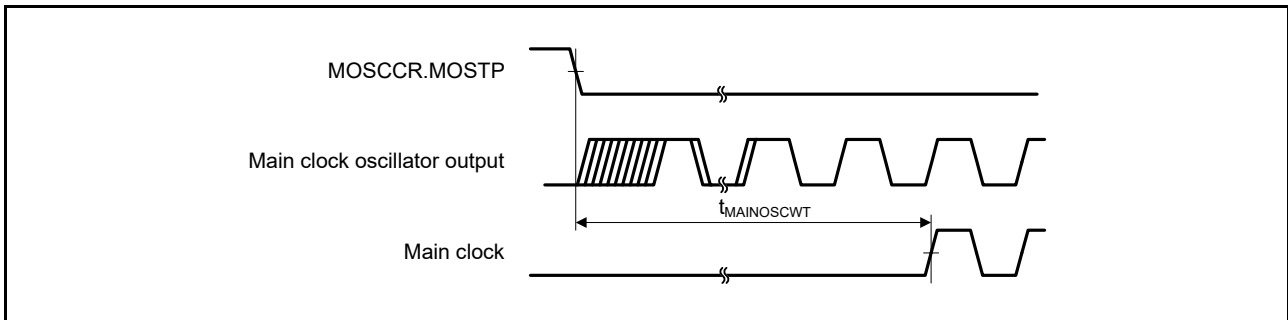

Figure 2.26 Main clock oscillation start timing

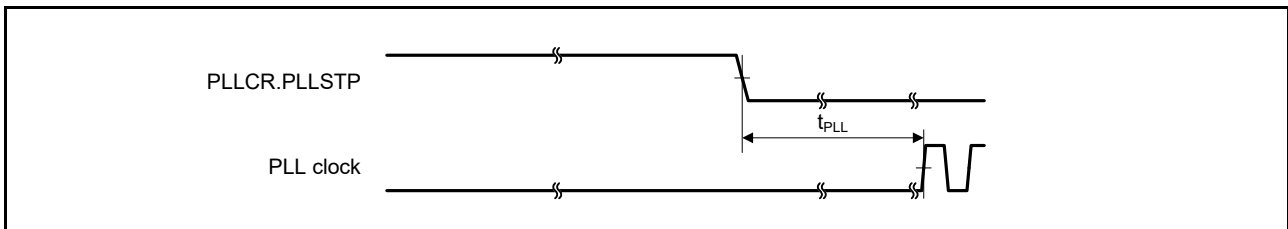

Figure 2.27 PLL clock oscillation start timing (PLL is operated after main clock oscillation has settled)

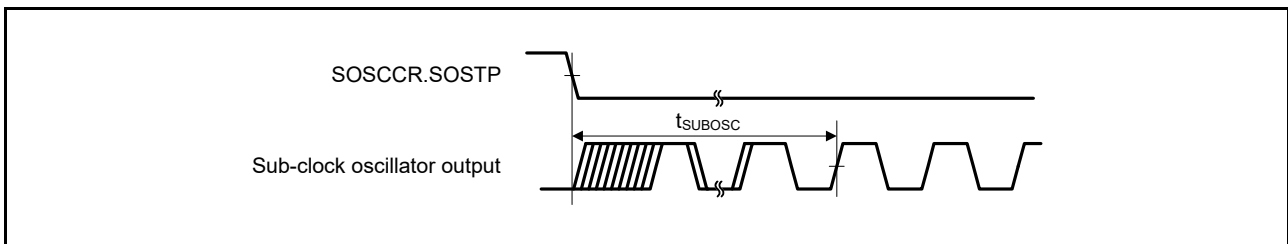

Figure 2.28 Sub-clock oscillation start timing

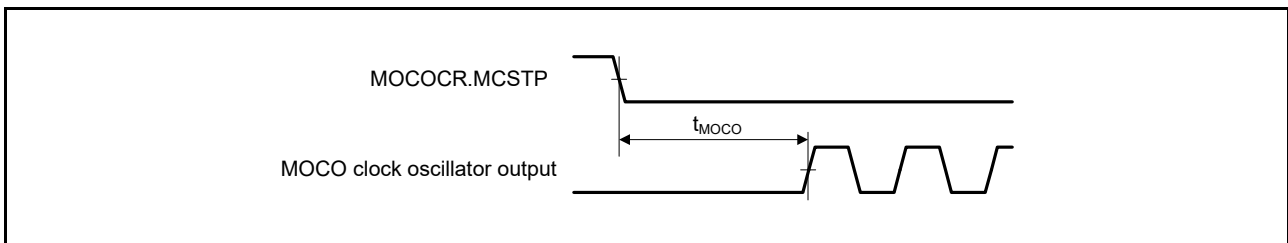

Figure 2.29 MOCO clock oscillation start timing

2.3.3 Reset Timing

Table 2.24 Reset timing

Parameter		Symbol	Min	Typ	Max	Unit	Test conditions
RES pulse width	At power-on	t_{RESWP}	3	-	-	ms	Figure 2.30
	Other than above	t_{RESW}	30	-	-	μ s	Figure 2.31
Wait time after RES cancellation (at power-on)	LVD0: enable*1	t_{RESWT}	-	0.7	-	ms	Figure 2.30
	LVD0: disable*2		-	0.3	-		
Wait time after RES cancellation (during powered-on state)	LVD0: enable*1	t_{RESWT2}	-	0.5	-	ms	Figure 2.31
	LVD0: disable*2		-	0.05	-		
Internal reset cancellation time (Watchdog timer reset, SRAM parity error reset, SRAM ECC error reset, Bus master MPU error reset, Bus slave MPU error reset, Stack pointer error reset, Software reset)	LVD0: enable*1	t_{RESWT3}	-	0.6	-	ms	
	LVD0: disable*2		-	0.15	-		

Note 1. When OFS1.LVDAS = 0.

Note 2. When OFS1.LVDAS = 1.

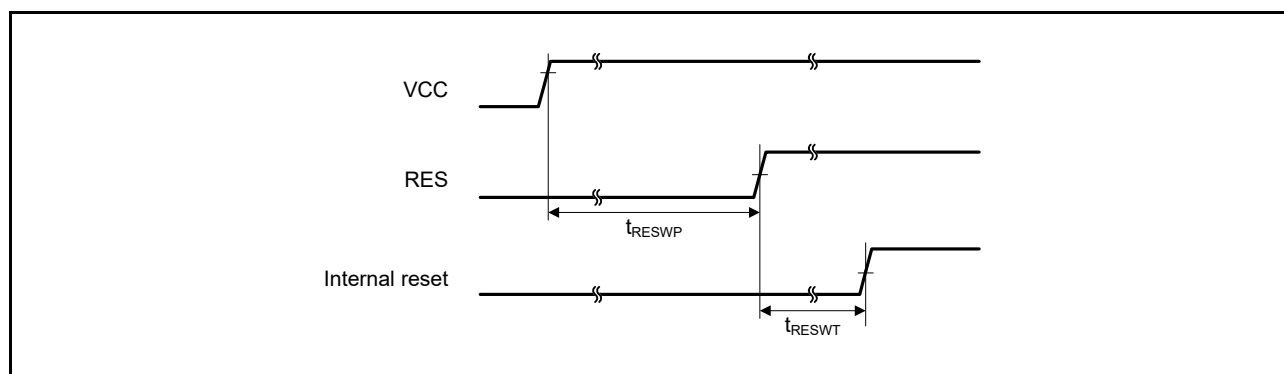

Figure 2.30 Reset input timing at power-on

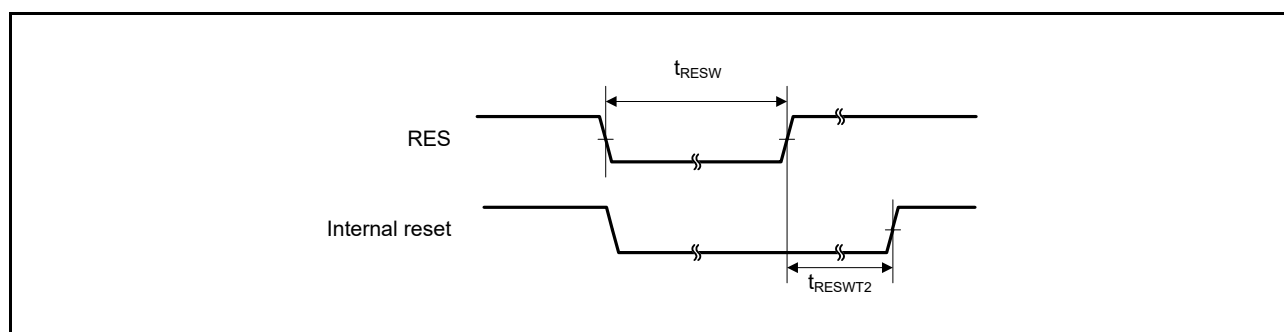

Figure 2.31 Reset input timing (1)

2.3.4 Wakeup Time

Table 2.25 Timing of recovery from low power modes (1)

Parameter				Symbol	Min	Typ	Max	Unit	Test conditions	
Recovery time from Software Standby mode*1	High-speed mode	Crystal resonator connected to main clock oscillator	System clock source is main clock oscillator (20 MHz)*2	t _{SBYMC}	-	2	3	ms	Figure 2.32	
			System clock source is PLL (48 MHz) with Main clock oscillator*2	t _{SBYPC}	-	2	3	ms		
		External clock input to main clock oscillator	System clock source is main clock oscillator (20 MHz)*3	t _{SBYEX}	-	14	25	μs		
			System clock source is PLL (48 MHz) with Main clock oscillator*3	t _{SBYPE}	-	53	76	μs		
		System clock source is HOCO*4 (HOCO clock is 32 MHz)			t _{SBYHO}	-	43	52		μs
		System clock source is HOCO*4 (HOCO clock is 48 MHz)			t _{SBYHO}	-	44	52		μs
		System clock source is HOCO*5 (HOCO clock is 64 MHz)			t _{SBYHO}	-	82	110		μs
		System clock source is MOCO			t _{SBYMO}	-	16	25		μs

Note 1. The division ratio of ICK, BCK, FCK, and PCKx is the minimum division ratio within the allowable frequency range. The recovery time is determined by the system clock source.

Note 2. The Main Clock Oscillator Wait Control Register (MOSCWTCR) is set to 05h.

Note 3. The Main Clock Oscillator Wait Control Register (MOSCWTCR) is set to 00h.

Note 4. The HOCO Clock Wait Control Register (HOCOWTCR) is set to 05h.

Note 5. The HOCO Clock Wait Control Register (HOCOWTCR) is set to 06h.

Table 2.26 Timing of recovery from low power modes (2)

Parameter				Symbol	Min	Typ	Max	Unit	Test conditions	
Recovery time from Software Standby mode*1	Middle-speed mode	Crystal resonator connected to main clock oscillator	System clock source is main clock oscillator (12 MHz)*2	t _{SBYMC}	-	2	3	ms	Figure 2.32	
			System clock source is PLL (24 MHz) with main clock oscillator*2	t _{SBYPC}	-	2	3	ms		
		External clock input to main clock oscillator	System clock source is main clock oscillator (12 MHz)*3	t _{SBYEX}	-	2.9	10	μs		
			System clock source is PLL (24 MHz) with main clock oscillator*3	t _{SBYPE}	-	49	76	μs		
		System clock source is HOCO (24 MHz)			t _{SBYHO}	-	38	50		μs
		System clock source is MOCO			t _{SBYMO}	-	3.5	5.5		μs

Note 1. The division ratio of ICK, BCK, FCK, and PCKx is the minimum division ratio within the allowable frequency range. The recovery time is determined by the system clock source.

Note 2. The Main Clock Oscillator Wait Control Register (MOSCWTCR) is set to 05h.

Note 3. The Main Clock Oscillator Wait Control Register (MOSCWTCR) is set to 00h.

Table 2.27 Timing of recovery from low power modes (3)

Parameter				Symbol	Min	Typ	Max	Unit	Test conditions
Recovery time from Software Standby mode*1	Low-speed mode	Crystal resonator connected to main clock oscillator	System clock source is main clock oscillator (1 MHz)*2	t_{SBYMC}	-	2	3	ms	Figure 2.32
		External clock input to main clock oscillator	System clock source is main clock oscillator (1 MHz)*3	t_{SBYEX}	-	28	50	μ s	
		System clock source is MOCO		t_{SBYMO}	-	25	35	μ s	

Note 1. The division ratio of ICK, BCK, FCK, and PCKx is the minimum division ratio within the allowable frequency range. The recovery time is determined by the system clock source.

Note 2. The Main Clock Oscillator Wait Control Register (MOSCWTCR) is set to 05h.

Note 3. The Main Clock Oscillator Wait Control Register (MOSCWTCR) is set to 00h.

Table 2.28 Timing of recovery from low power modes (4)

Parameter				Symbol	Min	Typ	Max	Unit	Test conditions
Recovery time from Software Standby mode*1	Low-voltage mode	Crystal resonator connected to main clock oscillator	System clock source is main clock oscillator (4 MHz)*2	t_{SBYMC}	-	2	3	ms	Figure 2.32
		External clock input to main clock oscillator	System clock source is main clock oscillator (4 MHz)*3	t_{SBYEX}	-	108	130	μ s	
		System clock source is HOCO		t_{SBYHO}	-	108	130	μ s	

Note 1. The division ratio of ICK, BCK, FCK, and PCKx is the minimum division ratio within the allowable frequency range. The recovery time is determined by the system clock source. When multiple oscillators are active, the recovery time can be determined by the following expression.

Note 2. The Main Clock Oscillator Wait Control Register (MOSCWTCR) is set to 05h.

Note 3. The Main Clock Oscillator Wait Control Register (MOSCWTCR) is set to 00h.

Table 2.29 Timing of recovery from low power modes (5)

Parameter			Symbol	Min	Typ	Max	Unit	Test conditions
Recovery time from Software Standby mode*1	Subosc-speed mode	System clock source is sub-clock oscillator (32.768 kHz)	t_{SBYSC}	-	0.85	1	ms	Figure 2.32
		System clock source is LOCO (32.768 kHz)	t_{SBYLO}	-	0.85	1.2	ms	

Note 1. The sub-clock oscillator or LOCO itself continues to oscillate in Software Standby mode during Subosc-speed mode.

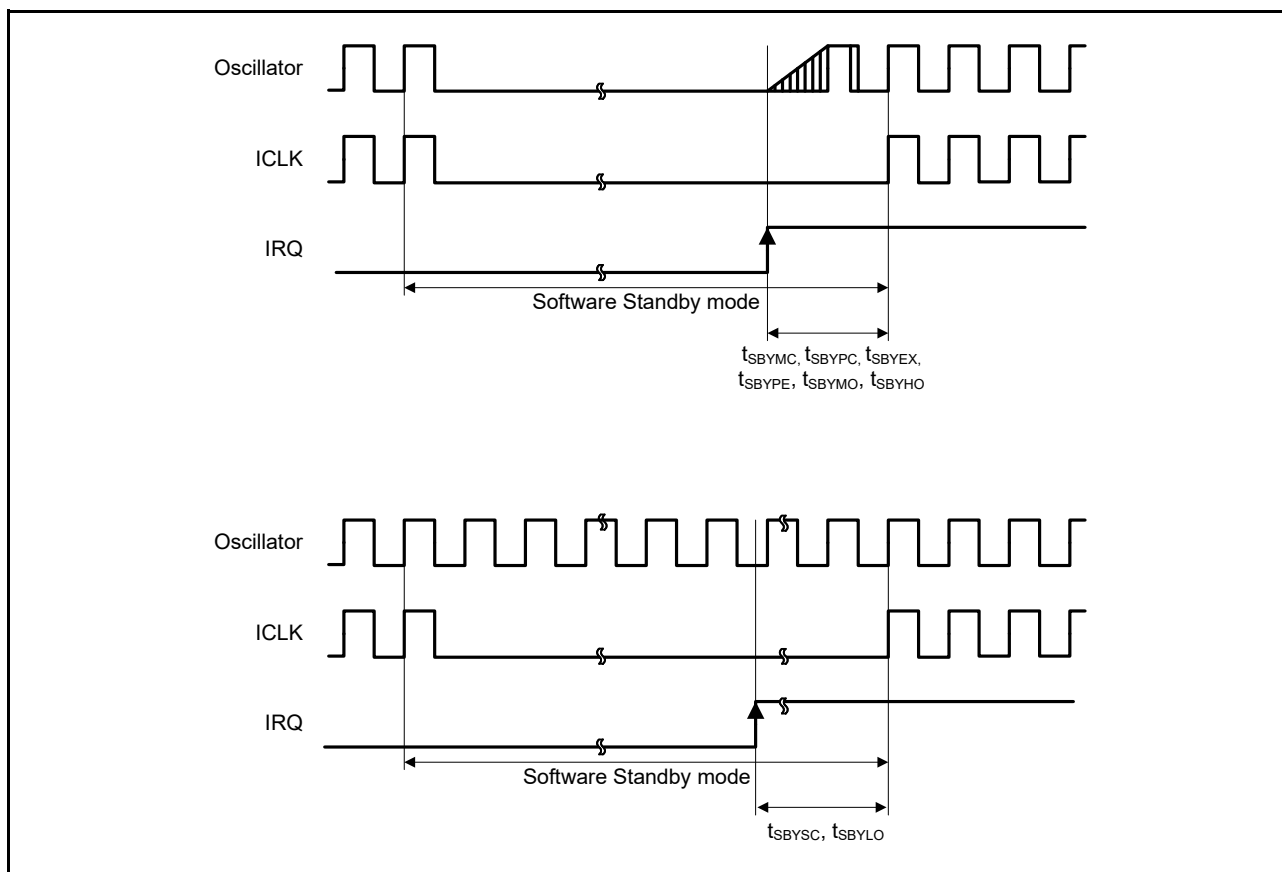

Figure 2.32 Software Standby mode cancellation timing

Table 2.30 Timing of recovery from low power modes (6)

Parameter	Symbol	Min	Typ	Max	Unit	Test conditions	
Recovery time from Software Standby mode to Snooze mode	High-speed mode System clock source is HOCO	t_{SNZ}	-	36	45	μs	Figure 2.33
	Middle-speed mode System clock source is MOCO	t_{SNZ}	-	1.3	3.6	μs	
	Low-speed mode System clock source is MOCO	t_{SNZ}	-	10	13	μs	
	Low-voltage mode System clock source is HOCO	t_{SNZ}	-	87	110	μs	

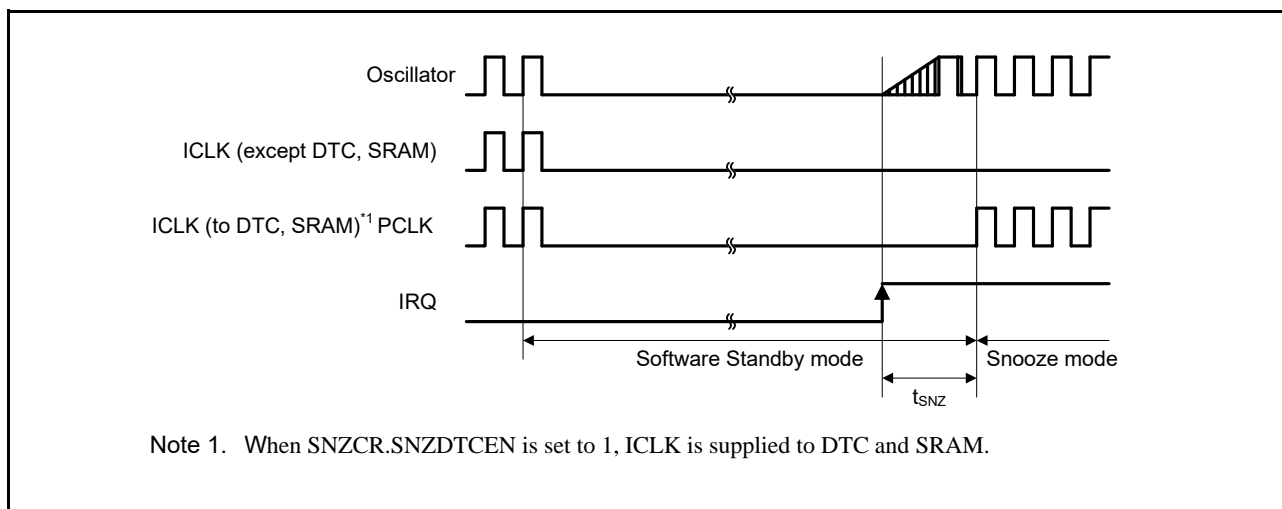

Figure 2.33 Recovery timing from Software Standby mode to Snooze mode

2.3.5 NMI and IRQ Noise Filter

Table 2.31 NMI and IRQ noise filter

Parameter	Symbol	Min	Typ	Max	Unit	Test conditions	
NMI pulse width	t_{NMIW}	200	-	-	ns	NMI digital filter disabled	$t_{Pcyc} \times 2 \leq 200$ ns
		$t_{Pcyc} \times 2^{*1}$	-	-			$t_{Pcyc} \times 2 > 200$ ns
		200	-	-		NMI digital filter enabled	$t_{NMICK} \times 3 \leq 200$ ns
		$t_{NMICK} \times 3.5^{*2}$	-	-			$t_{NMICK} \times 3 > 200$ ns
IRQ pulse width	t_{IRQW}	200	-	-	ns	IRQ digital filter disabled	$t_{Pcyc} \times 2 \leq 200$ ns
		$t_{Pcyc} \times 2^{*1}$	-	-			$t_{Pcyc} \times 2 > 200$ ns
		200	-	-		IRQ digital filter enabled	$t_{IRQCK} \times 3 \leq 200$ ns
		$t_{IRQCK} \times 3.5^{*3}$	-	-			$t_{IRQCK} \times 3 > 200$ ns

- Note: 200 ns minimum in Software Standby mode.
- Note: If the clock source is switched, add 4 clock cycles of the switched source.
- Note 1. t_{Pcyc} indicates the cycle of PCLKB.
- Note 2. t_{NMICK} indicates the cycle of the NMI digital filter sampling clock.
- Note 3. t_{IRQCK} indicates the cycle of the IRQ_i digital filter sampling clock (i = 0 to 15).

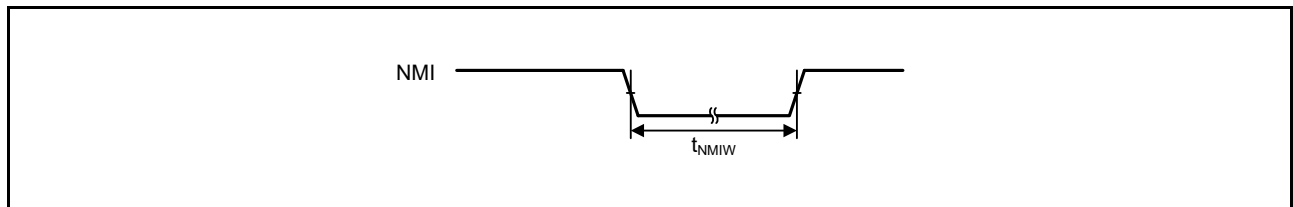

Figure 2.34 NMI interrupt input timing

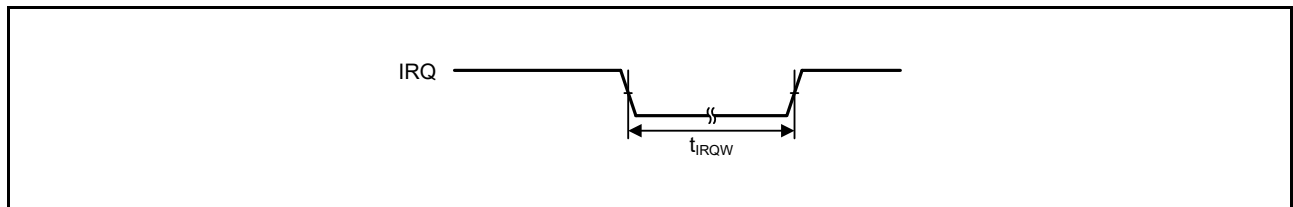

Figure 2.35 IRQ interrupt input timing

2.3.6 I/O Ports, POEG, GPT, AGT, KINT, and ADC14 Trigger Timing

Table 2.32 I/O Ports, POEG, GPT, AGT, KINT, and ADC14 trigger timing

Parameter		Symbol	Min	Max	Unit	Test conditions	
I/O ports	Input data pulse width	t_{PRW}	1.5	-	t_{Pcyc}	Figure 2.36	
	Input/output data cycle (P004)	t_{POCyc}	10	-	us		
POEG	POEG input trigger pulse width	t_{POEW}	3	-	t_{Pcyc}	Figure 2.37	
GPT	Input capture pulse width	Single edge	t_{GTICW}	1.5	t_{PDcyc}	Figure 2.38	
		Dual edge		2.5			
AGT	AGTIO, AGTEE input cycle	$2.7\text{ V} \leq VCC \leq 3.6\text{ V}$	t_{ACYC}^{*1}	250	ns	Figure 2.39	
		$2.4\text{ V} \leq VCC < 2.7\text{ V}$		500			
		$1.8\text{ V} \leq VCC < 2.4\text{ V}$		1000			
	AGTIO, AGTEE input high level width, low-level width	$2.7\text{ V} \leq VCC \leq 3.6\text{ V}$	t_{ACKWH} , t_{ACKWL}	100	ns		
		$2.4\text{ V} \leq VCC < 2.7\text{ V}$		200			
		$1.8\text{ V} \leq VCC < 2.4\text{ V}$		400			
	AGTIO, AGTO, AGTOB output cycle	$2.7\text{ V} \leq VCC \leq 3.6\text{ V}$	t_{ACYC2}	62.5	ns		Figure 2.39
		$2.4\text{ V} \leq VCC < 2.7\text{ V}$		125			
		$1.8\text{ V} \leq VCC < 2.4\text{ V}$		250			
ADC14	14-bit A/D converter trigger input pulse width	t_{TRGW}	1.5	-	t_{Pcyc}	Figure 2.40	
KINT	KRn (n = 00 to 07) pulse width	t_{KR}	250	-	ns	Figure 2.41	

Note 1. Constraints on input cycle:
 When not switching the source clock: $t_{Pcyc} \times 2 < t_{ACYC}$ should be satisfied.
 When switching the source clock: $t_{Pcyc} \times 6 < t_{ACYC}$ should be satisfied.

Note: t_{Pcyc} : PCLKB cycle, t_{PDcyc} : PCLKD cycle

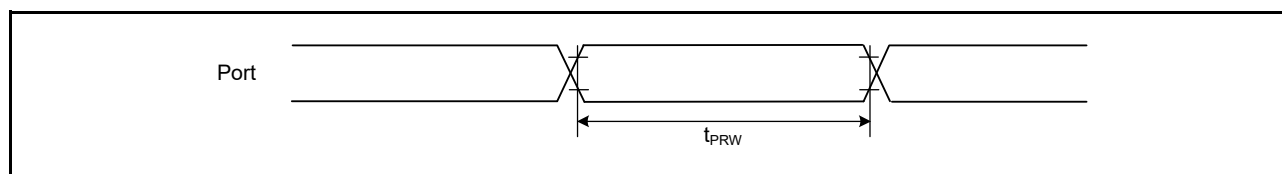

Figure 2.36 I/O ports input timing

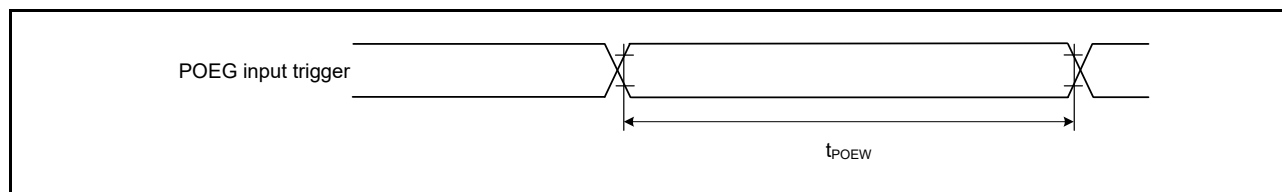

Figure 2.37 POEG input trigger timing

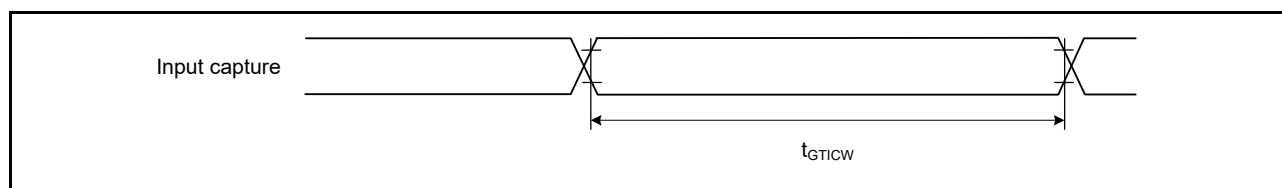

Figure 2.38 GPT input capture timing

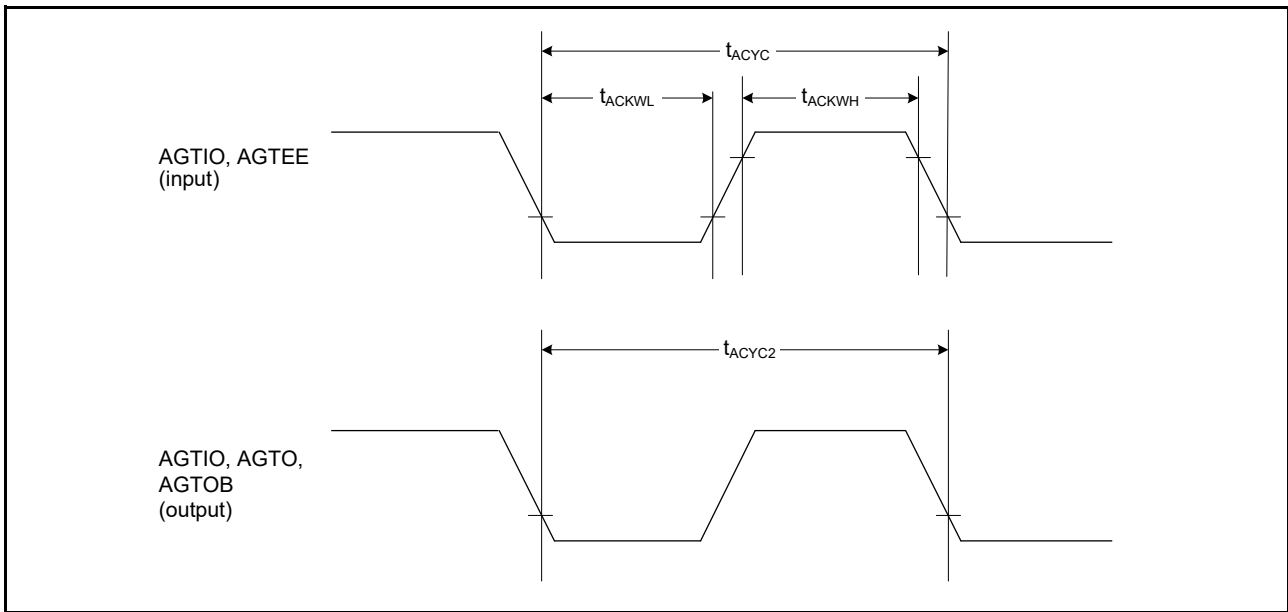

Figure 2.39 AGT I/O timing

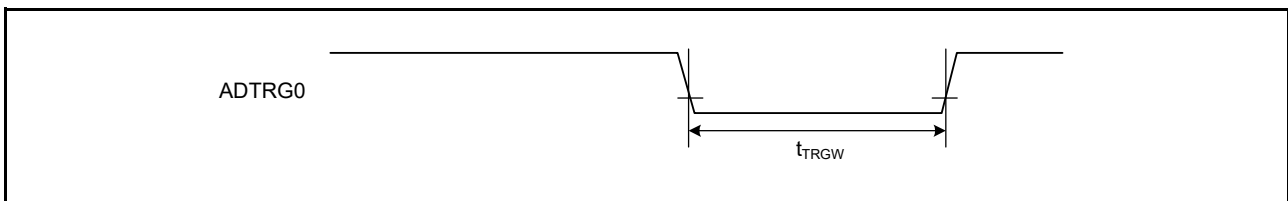

Figure 2.40 ADC14 trigger input timing

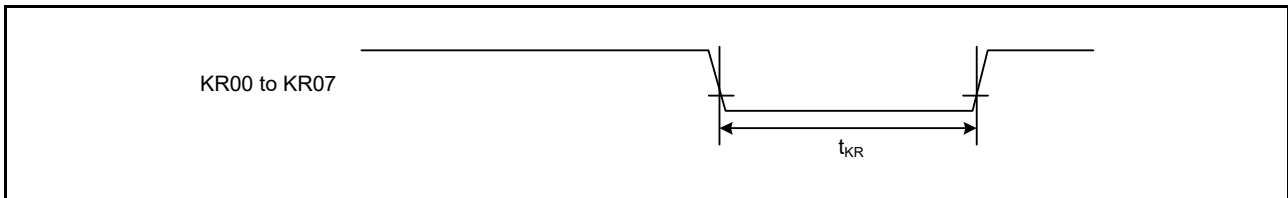

Figure 2.41 Key interrupt input timing

2.3.7 CAC Timing

Table 2.33 CAC timing

Parameter		Symbol	Min	Typ	Max	Unit	Test conditions
CAC	CACREF input pulse width	t_{CACREF}	$t_{PBcyc}^{*1} \leq t_{cac}^{*2}$	$4.5 \times t_{cac} + 3 \times t_{PBcyc}^{*1}$	-	-	ns
			$t_{PBcyc}^{*1} > t_{cac}^{*2}$	$5 \times t_{cac} + 6.5 \times t_{PBcyc}^{*1}$	-	-	ns

Note 1. t_{PBcyc} : PCLKB cycle.

Note 2. t_{cac} : CAC count clock source cycle.

2.3.8 SCI Timing

Table 2.34 SCI timing (1)

Parameter			Symbol	Min	Max	Unit*1	Test conditions
SCI	Input clock cycle	Asynchronous	t_{Scyc}	4	-	t_{Pcyc}	Figure 2.42
		Clock synchronous		6	-		
	Input clock pulse width		t_{SCKW}	0.4	0.6	t_{Scyc}	
	Input clock rise time		t_{SCKr}	-	20	ns	
	Input clock fall time		t_{SCKf}	-	20	ns	
	Output clock cycle	Asynchronous	t_{Scyc}	6	-	t_{Pcyc}	
		Clock synchronous		4	-		
	Output clock pulse width		t_{SCKW}	0.4	0.6	t_{Scyc}	
	Output clock rise time	1.8 V or above	t_{SCKr}	-	20	ns	
	Output clock fall time	1.8 V or above	t_{SCKf}	-	20	ns	
Transmit data delay (master)	Clock synchronous	1.8 V or above	t_{TXD}	-	40	ns	Figure 2.43
Transmit data delay (slave)	Clock synchronous	2.7 V or above		-	55	ns	
		2.4 V or above		-	60		
		1.8 V or above		-	100		
Receive data setup time (master)	Clock synchronous	2.7 V or above	t_{RXS}	45	-	ns	
		2.4 V or above		55	-		
		1.8 V or above		90	-		
Receive data setup time (slave)	Clock synchronous	2.7 V or above		40	-	ns	
		1.8 V or above		45	-		
Receive data hold time (master)	Clock synchronous		t_{RXH}	5	-	ns	
Receive data hold time (slave)	Clock synchronous		t_{RXH}	40	-	ns	

Note 1. t_{Pcyc} : PCLKA cycle.

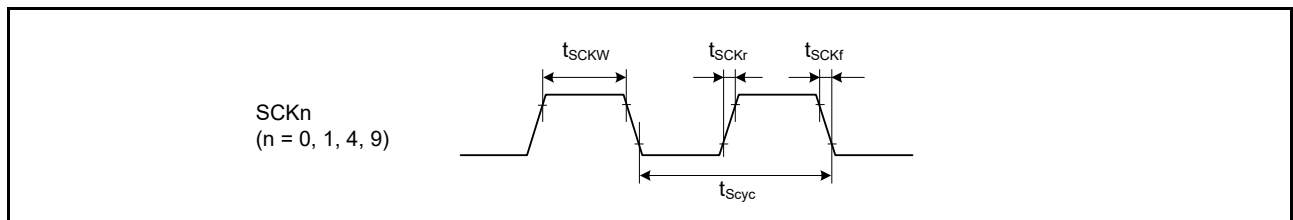

Figure 2.42 SCK clock input timing

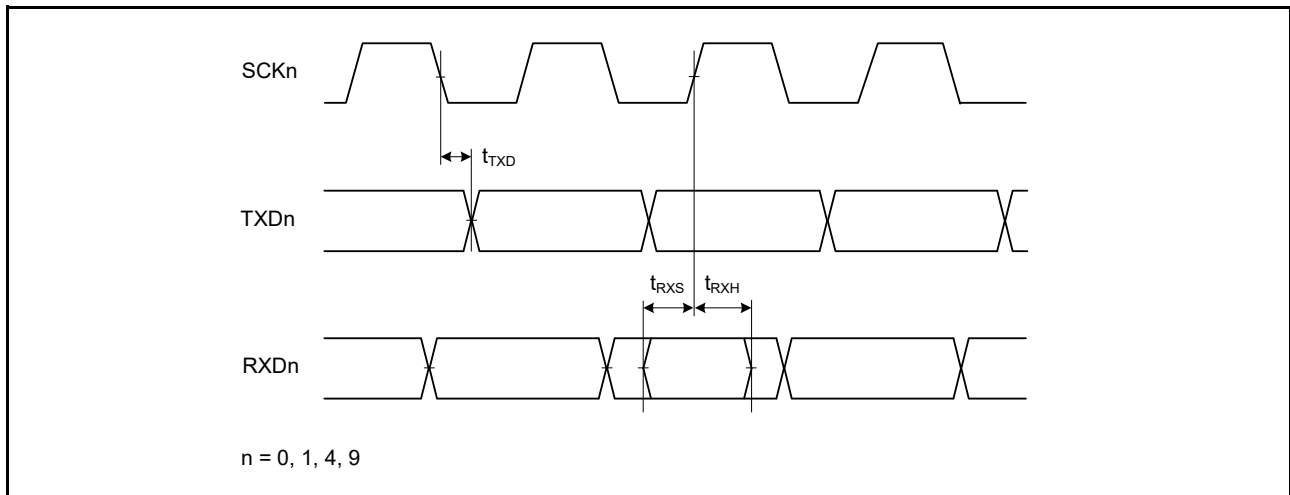

Figure 2.43 SCI input/output timing in clock synchronous mode

Table 2.35 SCI timing (2)

Parameter			Symbol	Min	Max	Unit	Test conditions
Simple SPI	SCK clock cycle output (master)		t_{SPcyc}	4	65536	t_{Pcyc}	Figure 2.44
	SCK clock cycle input (slave)			6	65536		
	SCK clock high pulse width		t_{SPCKWH}	0.4	0.6	t_{SPcyc}	
	SCK clock low pulse width		t_{SPCKWL}	0.4	0.6	t_{SPcyc}	
	SCK clock rise and fall time		t_{SPCKr} , t_{SPCKf}	-	20	ns	
Data input setup time	Master	2.7 V or above	t_{SU}	45	-	ns	Figure 2.45 to Figure 2.48
		2.4 V or above		55	-		
		1.8 V or above		80	-		
	Slave	2.7 V or above		40	-		
		1.8 V or above		45	-		
Data input hold time	Master		t_H	33.3	-	ns	
	Slave			40	-		
SS input setup time			t_{LEAD}	1	-	t_{SPcyc}	
SS input hold time			t_{LAG}	1	-	t_{SPcyc}	
Data output delay	Master	1.8 V or above	t_{OD}	-	40	ns	
		2.4 V or above		-	65		
		1.8 V or above		-	100		
Data output hold time	Master	2.7 V or above	t_{OH}	-10	-	ns	
		2.4 V or above		-20	-		
		1.8 V or above		-30	-		
	Slave			-10	-		
Data rise and fall time	Master	1.8 V or above	t_{Dr} , t_{Df}	-	20	ns	
	Slave	1.8 V or above		-	20		
Slave access time			t_{SA}	-	10 (PCLKA > 32 MHz), 6 (PCLKA ≤ 32 MHz)	t_{Pcyc}	Figure 2.47 and Figure 2.48
Slave output release time			t_{REL}	-	10 (PCLKA > 32 MHz), 6 (PCLKA ≤ 32 MHz)	t_{Pcyc}	

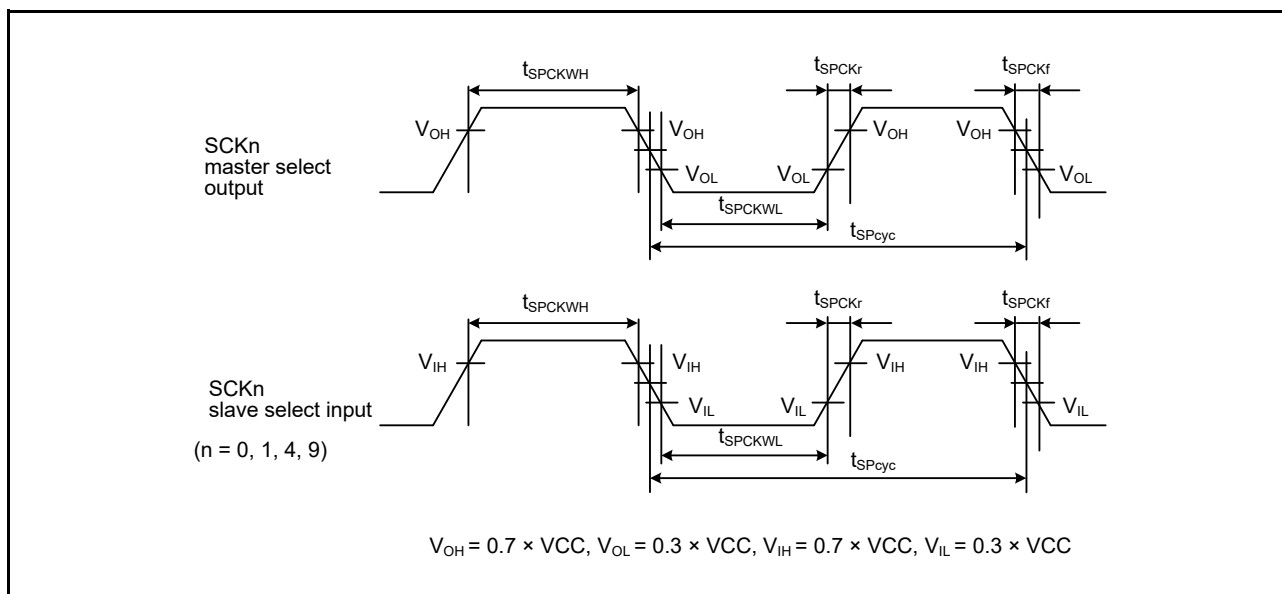

Figure 2.44 SCI simple SPI mode clock timing

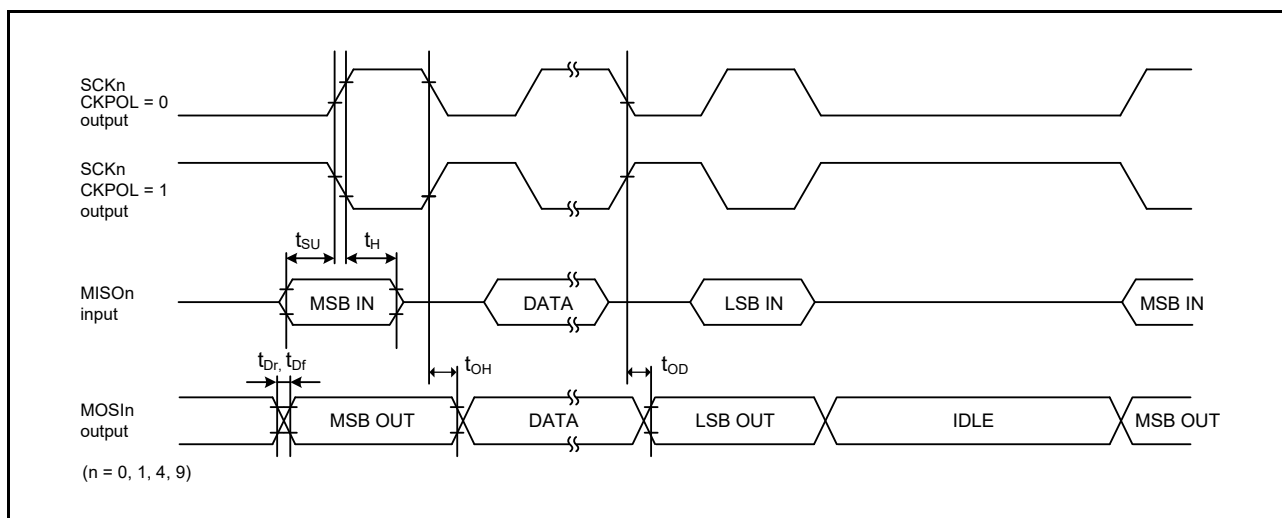

Figure 2.45 SCI simple SPI mode timing (master, CKPH = 1)

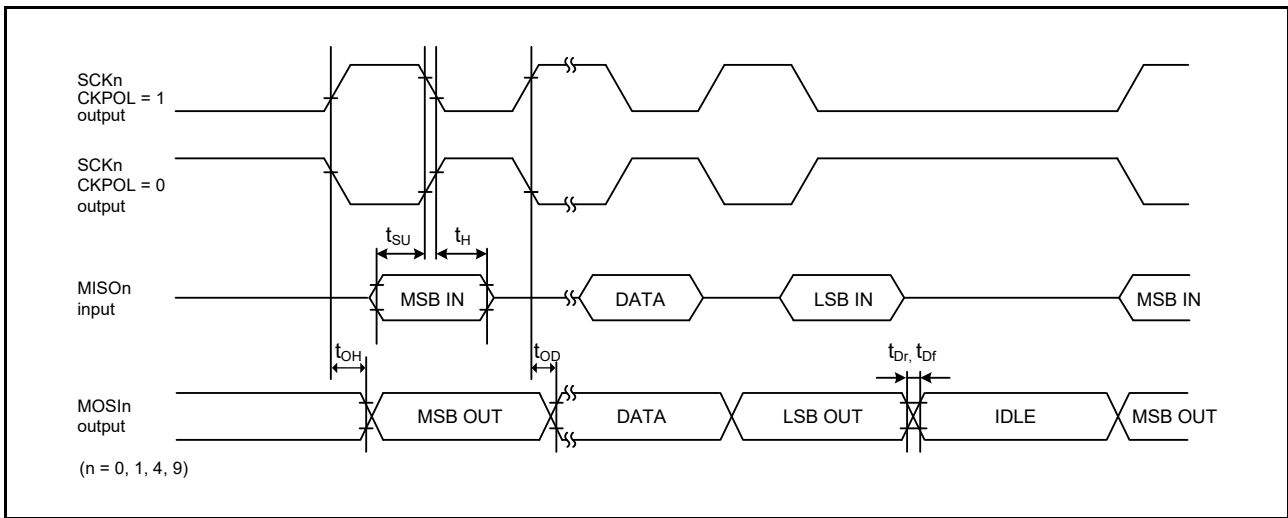

Figure 2.46 SCI simple SPI mode timing (master, CKPH = 0)

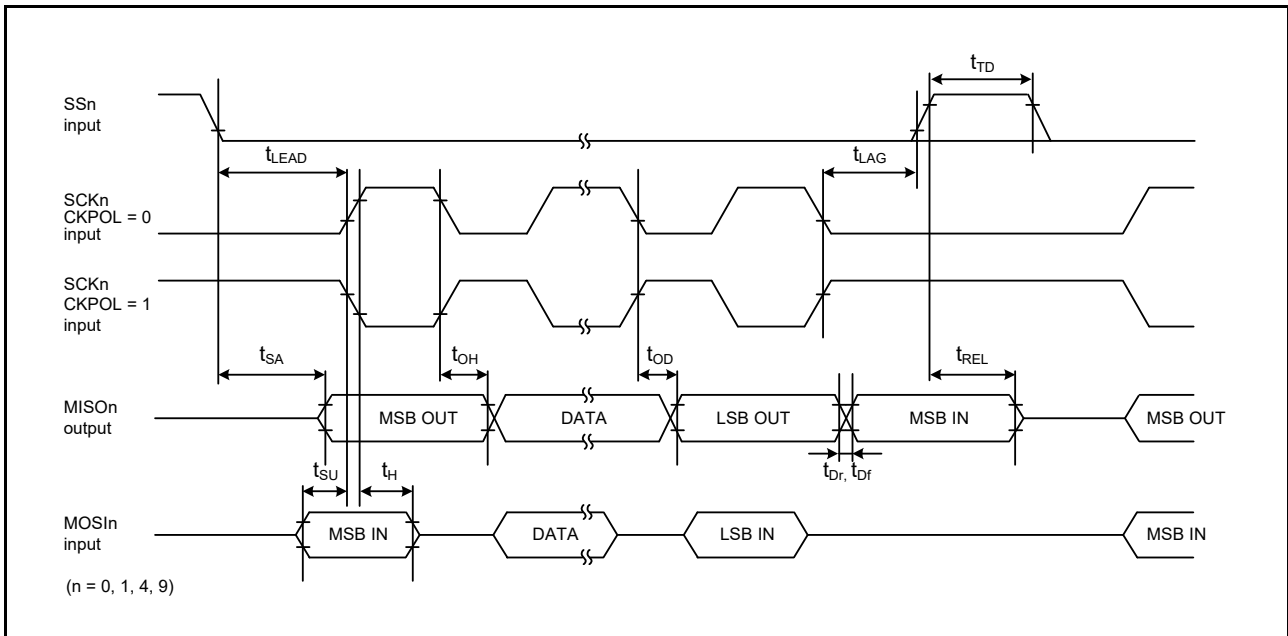

Figure 2.47 SCI simple SPI mode timing (slave, CKPH = 1)

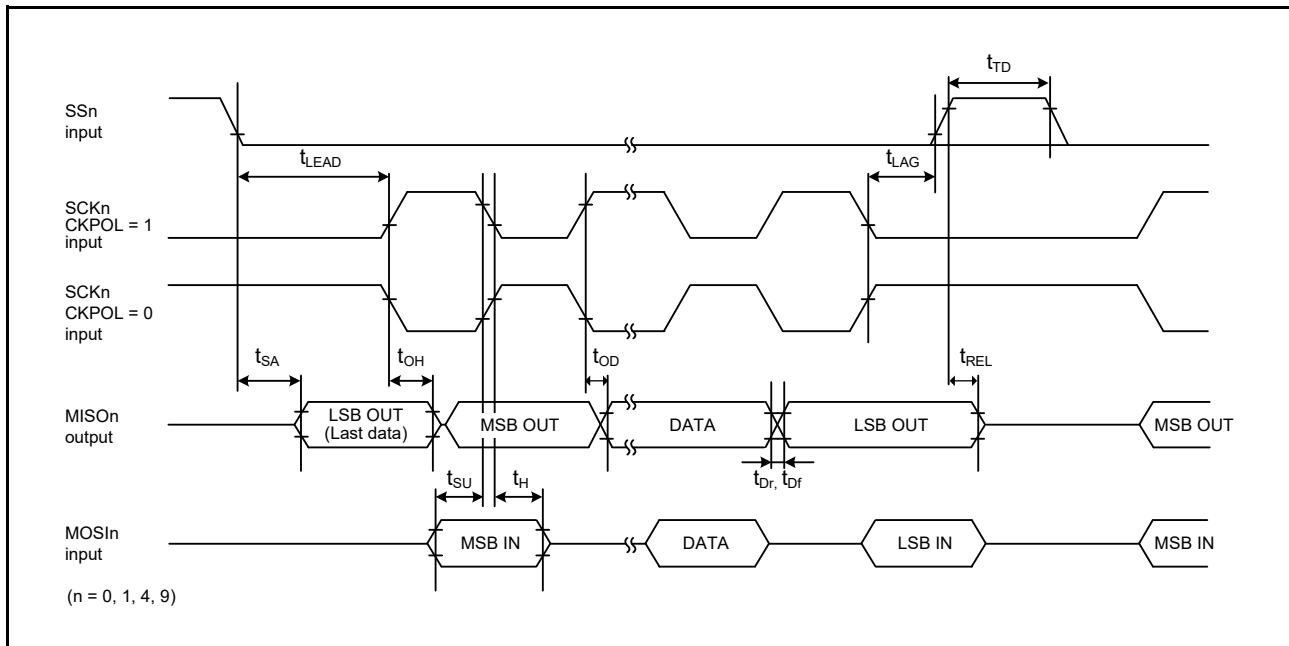

Figure 2.48 SCI simple SPI mode timing (slave, CKPH = 0)

Table 2.36 SCI timing (3)

Conditions: VCC = 2.7 to 3.6 V

Parameter	Symbol	Min	Max	Unit	Test conditions	
Simple IIC (Standard mode)	SDA input rise time	t_{Sr}	-	1000	ns	Figure 2.49
	SDA input fall time	t_{Sf}	-	300	ns	
	SDA input spike pulse removal time	t_{SP}	0	$4 \times t_{IICyc}^{*1}$	ns	
	Data input setup time	t_{SDAS}	250	-	ns	
	Data input hold time	t_{SDAH}	0	-	ns	
	SCL, SDA capacitive load	C_b^{*2}	-	400	pF	
Simple IIC (Fast mode)	SDA input rise time	t_{Sr}	-	300	ns	Figure 2.49 For all ports use PmnPFS.DSCR of middle drive.
	SDA input fall time	t_{Sf}	-	300	ns	
	SDA input spike pulse removal time	t_{SP}	0	$4 \times t_{IICyc}^{*1}$	ns	
	Data input setup time	t_{SDAS}	100	-	ns	
	Data input hold time	t_{SDAH}	0	-	ns	
	SCL, SDA capacitive load	C_b^{*2}	-	400	pF	

Note 1. t_{IICyc} : Clock cycle selected by the SMR.CKS[1:0] bits.

Note 2. C_b indicates the total capacity of the bus line.

2.3.9 SPI Timing

Table 2.37 SPI timing (1 of 2)

Conditions: Middle drive output is selected in the Port Drive Capability in PmnPFS register

Parameter			Symbol	Min	Max	Unit*1	Test conditions
SPI	RSPCK clock cycle	Master	t_{SPCyc}	2*4	4096	t_{Pcyc}	Figure 2.50
		Slave		6	4096		
RSPCK clock high pulse width	Master	t_{SPCKWH}	$(t_{SPCyc} - t_{SPCKr} - t_{SPCKf}) / 2 - 3$	-	ns		
	Slave			$3 \times t_{Pcyc}$	-		
RSPCK clock low pulse width	Master	t_{SPCKWL}	$(t_{SPCyc} - t_{SPCKr} - t_{SPCKf}) / 2 - 3$	-	ns		
	Slave			$3 \times t_{Pcyc}$	-		
RSPCK clock rise and fall time	Output	2.7 V or above	t_{SPCKr} , t_{SPCKf}	-	10	ns	
		2.4 V or above		-	15		
		1.8 V or above		-	20		
	Input	-	1	μ s			
Data input setup time	Master	t_{SU}	10	-	ns	Figure 2.51 to Figure 2.56	
	Slave		2.4 V or above	10			-
			1.8 V or above	15			-
Data input hold time	Master (RSPCK is PCLKA/2)		t_{HF}	0	-	ns	
	Master (RSPCK is other than above.)		t_H	t_{Pcyc}	-		
	Slave		t_H	20	-		
SSL setup time	Master	1.8 V or above	t_{LEAD}	$-30 + N \times t_{SPcyc}^{*2}$	-	ns	
	Slave			$6 \times t_{Pcyc}$	-		
SSL hold time	Master		t_{LAG}	$-30 + N \times t_{SPcyc}^{*3}$	-	ns	
	Slave			$6 \times t_{Pcyc}$	-		
Data output delay	Master	2.7 V or above	t_{OD}	-	14	ns	Figure 2.51 to Figure 2.56
		2.4 V or above		-	20		
		1.8 V or above		-	25		
	Slave	2.7 V or above		-	50		
		2.4 V or above		-	60		
		1.8 V or above		-	85		
Data output hold time	Master		t_{OH}	0	-	ns	
	Slave			0	-		
Successive transmission delay	Master		t_{TD}	$t_{SPcyc} + 2 \times t_{Pcyc}$	$8 \times t_{SPcyc} + 2 \times t_{Pcyc}$	ns	
	Slave			$6 \times t_{Pcyc}$	-		
MOSI and MISO rise and fall time	Output	2.7 V or above	t_{Dr} , t_{Df}	-	10	ns	
		2.4 V or above		-	15		
		1.8 V or above		-	20		
	Input	-		1	μ s		

Table 2.37 SPI timing (2 of 2)

Conditions: Middle drive output is selected in the Port Drive Capability in PmnPFS register

Parameter			Symbol	Min	Max	Unit*1	Test conditions	
SPI	SSL rise and fall time	Output	2.7 V or above	t_{SSLr}	-	10	ns	Figure 2.51 to Figure 2.56
			2.4 V or above	t_{SSLf}	-	15		
			1.8 V or above		-	20		
	Input			-	1	μ s		
Slave access time		2.4 V or above	t_{SA}	-	$2 \times t_{Pcyc} + 100$	ns	Figure 2.55 and Figure 2.56	
		1.8 V or above		-	$2 \times t_{Pcyc} + 140$			
Slave output release time		2.4 V or above	t_{REL}	-	$2 \times t_{Pcyc} + 100$	ns		
		1.8 V or above		-	$2 \times t_{Pcyc} + 140$			

Note 1. t_{Pcyc} : PCLKA cycle.

Note 2. N is set as an integer from 1 to 8 by the SPCKD register.

Note 3. N is set as an integer from 1 to 8 by the SSLND register.

Note 4. The upper limit of RSPCK is 16 MHz.

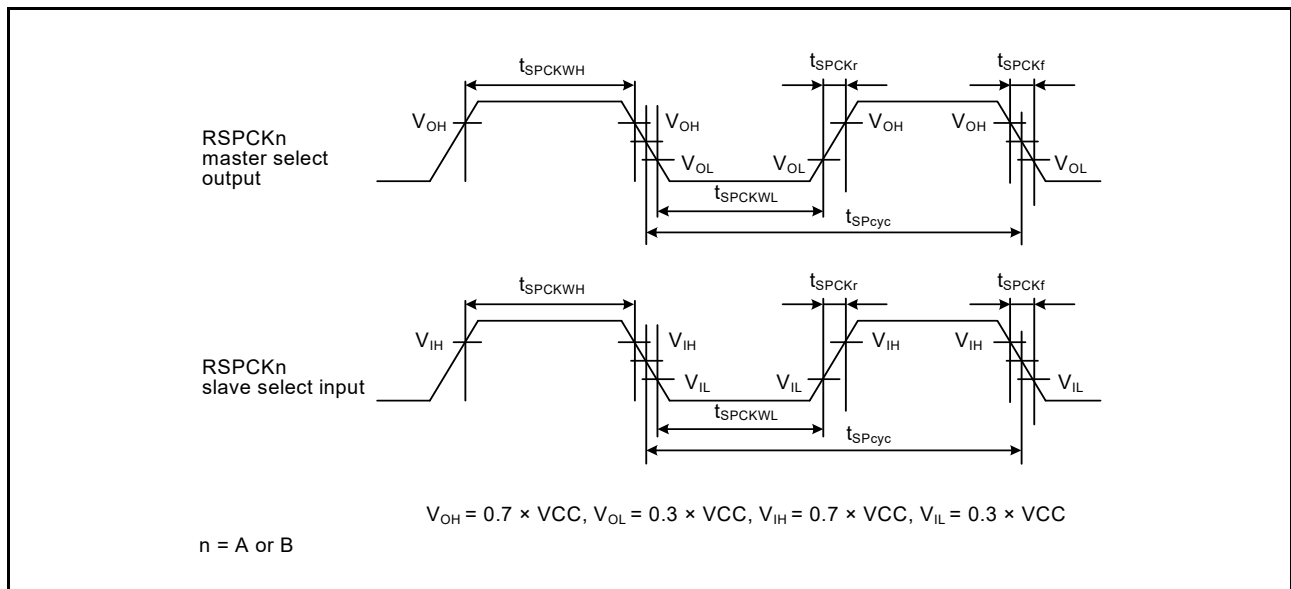

Figure 2.50 SPI clock timing

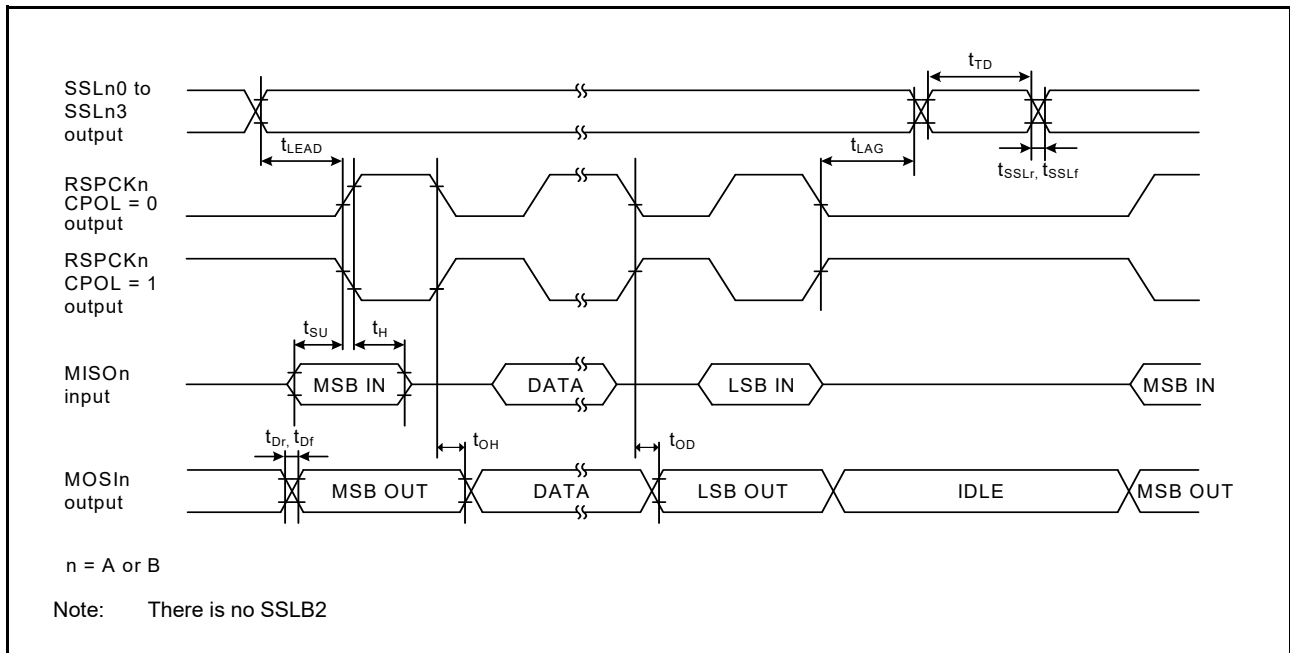

Figure 2.51 SPI timing (master, CPHA = 0) (bit rate: PCLKA division ratio is set to any value other than 1/2)

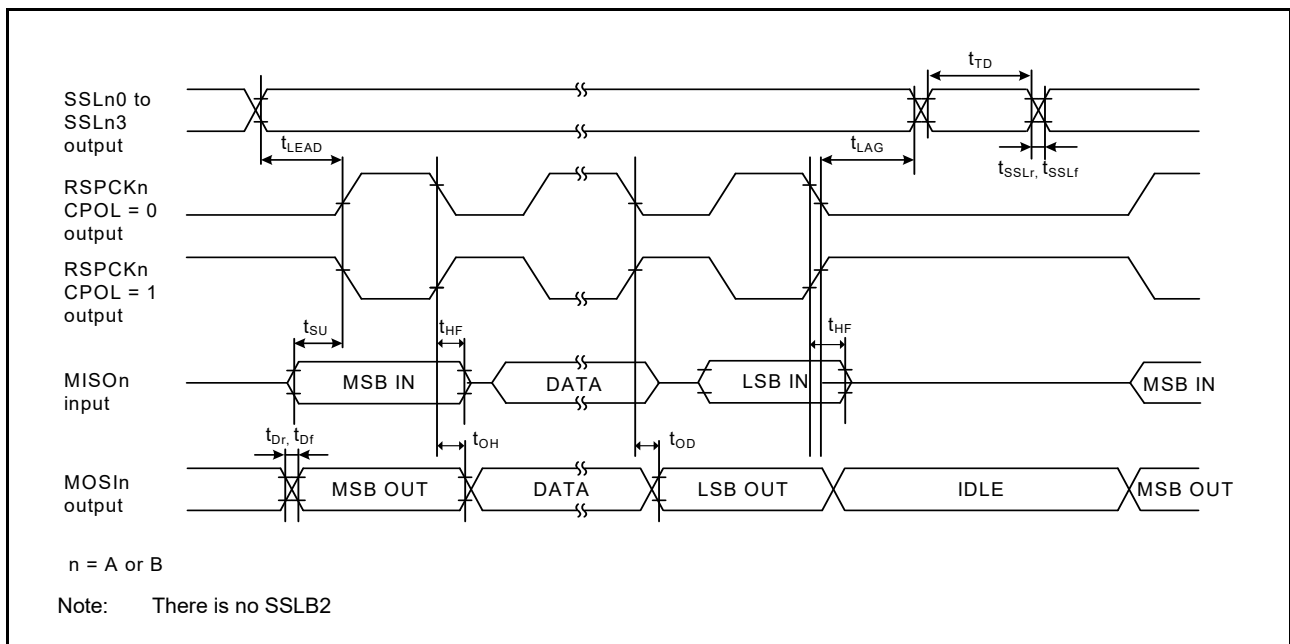

Figure 2.52 SPI timing (master, CPHA = 0) (bit rate: PCLKA division ratio is set to 1/2)

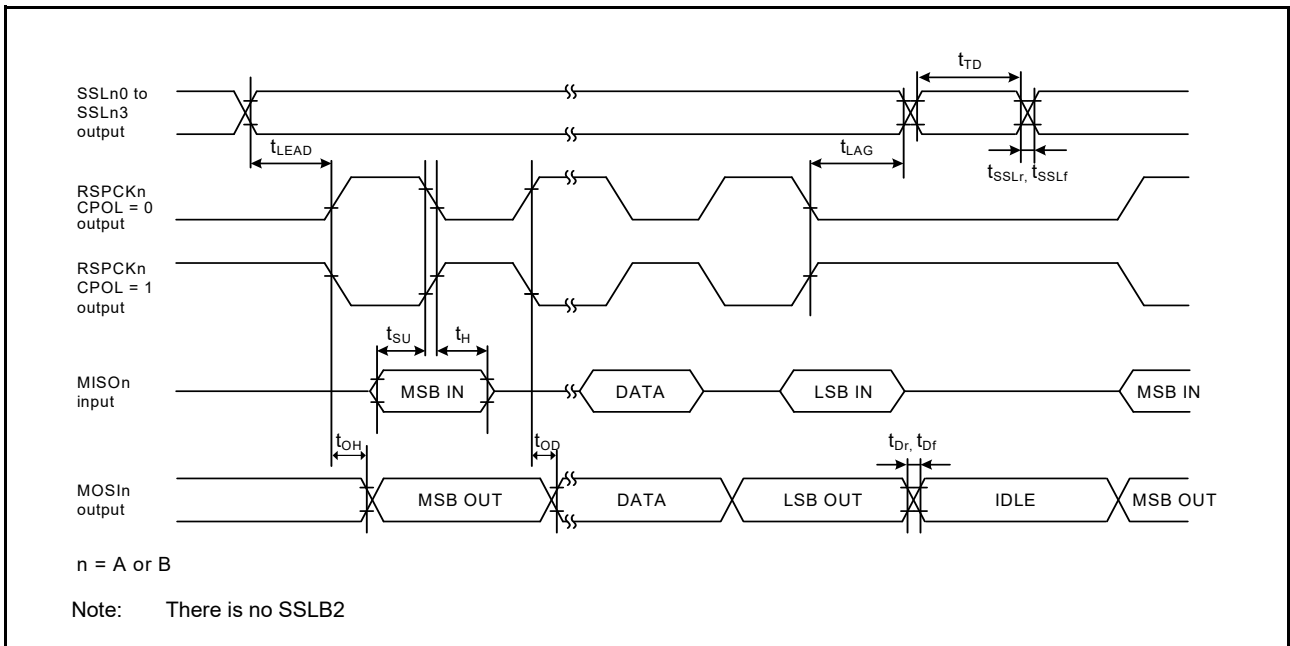

Figure 2.53 SPI timing (master, CPHA = 1) (bit rate: PCLKA division ratio is set to any value other than 1/2)

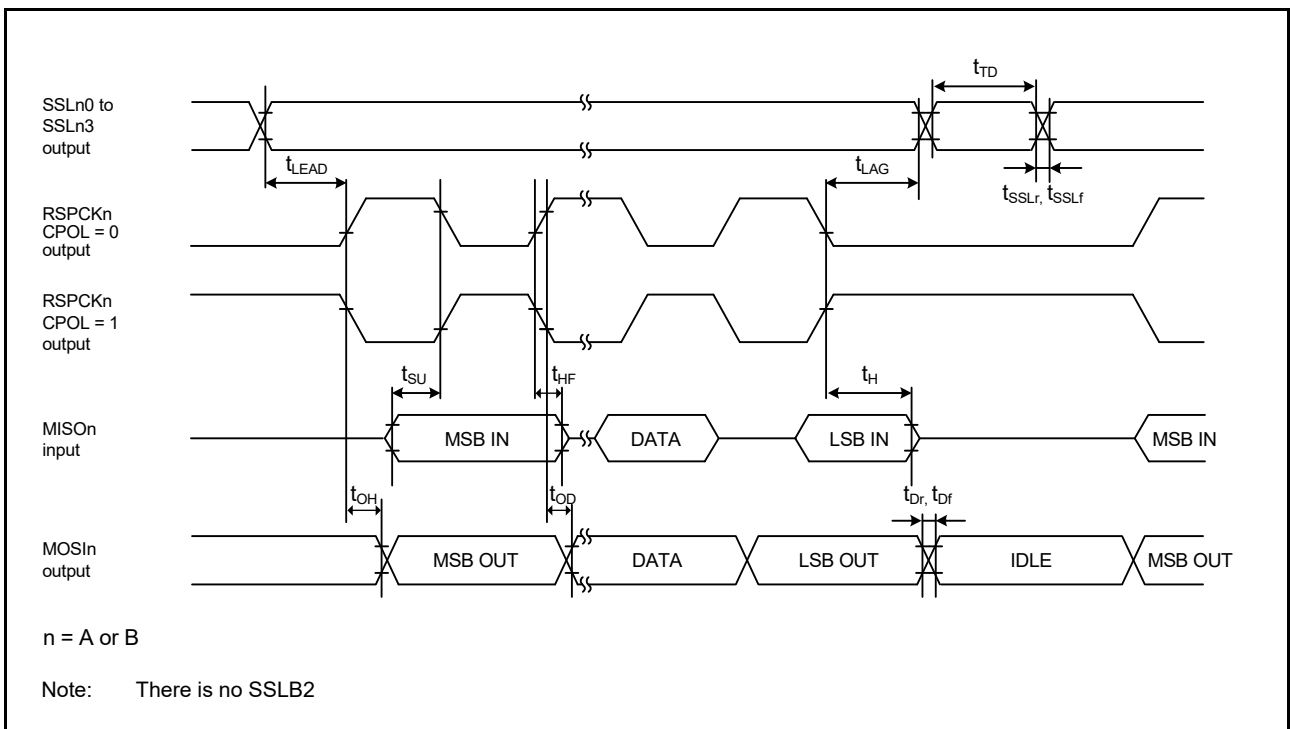

Figure 2.54 SPI timing (master, CPHA = 1) (bit rate: PCLKA division ratio is set to 1/2)

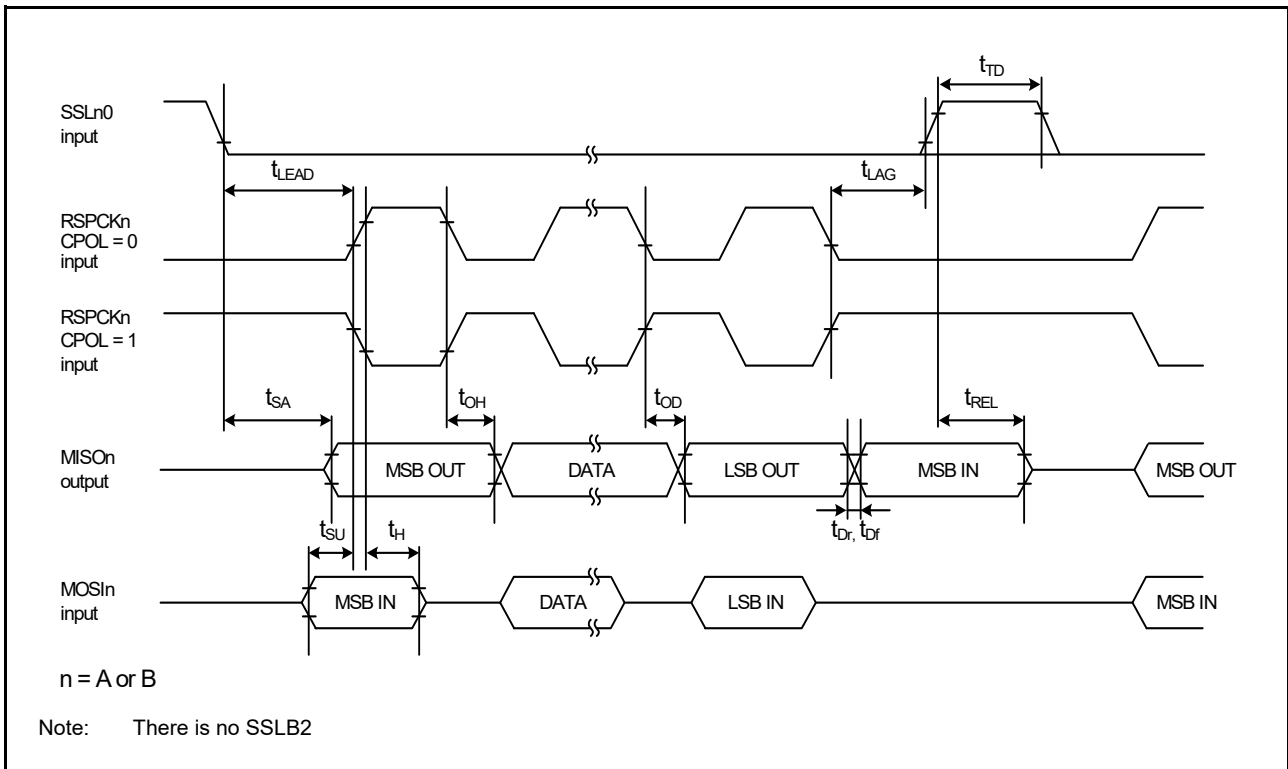

Figure 2.55 SPI timing (slave, CPHA = 0)

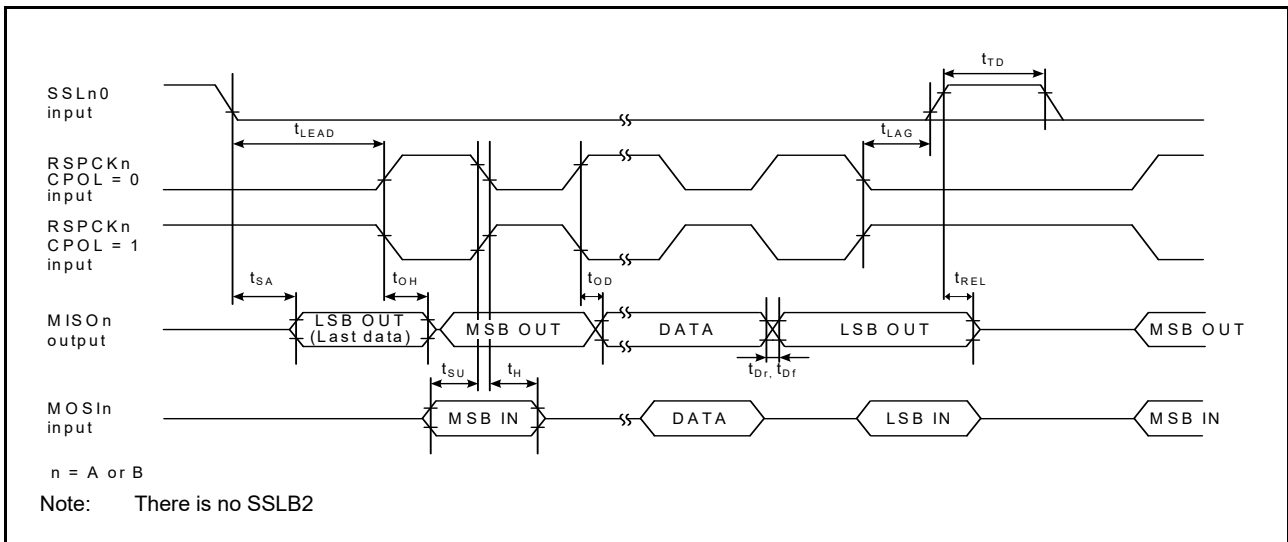

Figure 2.56 SPI timing (slave, CPHA = 1)

2.3.10 IIC Timing

Table 2.38 IIC timing
Conditions: VCC = 2.7 to 3.6 V

Parameter		Symbol	Min*1	Max	Unit	Test conditions
IIC (standard mode, SMBus)	SCL input cycle time	t_{SCL}	$6 (12) \times t_{IICcyc} + 1300$	-	ns	Figure 2.57
	SCL input high pulse width	t_{SCLH}	$3 (6) \times t_{IICcyc} + 300$	-	ns	
	SCL input low pulse width	t_{SCLL}	$3 (6) \times t_{IICcyc} + 300$	-	ns	
	SCL, SDA input rise time	t_{Sr}	-	1000	ns	
	SCL, SDA input fall time	t_{Sf}	-	300	ns	
	SCL, SDA input spike pulse removal time	t_{SP}	0	$1 (4) \times t_{IICcyc}$	ns	
	SDA input bus free time (When wakeup function is disabled)	t_{BUF}	$3 (6) \times t_{IICcyc} + 300$	-	ns	
	SDA input bus free time (When wakeup function is enabled)	t_{BUF}	$3 (6) \times t_{IICcyc} + 4 \times t_{Pcyc} + 300$	-	ns	
	START condition input hold time (When wakeup function is disabled)	t_{STAH}	$t_{IICcyc} + 300$	-	ns	
	START condition input hold time (When wakeup function is enabled)	t_{STAH}	$1 (5) \times t_{IICcyc} + t_{Pcyc} + 300$	-	ns	
	Repeated START condition input setup time	t_{STAS}	1000	-	ns	
	STOP condition input setup time	t_{STOS}	1000	-	ns	
	Data input setup time	t_{SDAS}	$t_{IICcyc} + 50$	-	ns	
	Data input hold time	t_{SDAH}	0	-	ns	
SCL, SDA capacitive load	C_b	-	400	pF		
IIC (Fast mode)	SCL input cycle time	t_{SCL}	$6 (12) \times t_{IICcyc} + 600$	-	ns	Figure 2.57 For all ports, use PmnPFS.DS CR of middle drive.
	SCL input high pulse width	t_{SCLH}	$3 (6) \times t_{IICcyc} + 300$	-	ns	
	SCL input low pulse width	t_{SCLL}	$3 (6) \times t_{IICcyc} + 300$	-	ns	
	SCL, SDA input rise time	t_{Sr}	-	300	ns	
	SCL, SDA input fall time	t_{Sf}	-	300	ns	
	SCL, SDA input spike pulse removal time	t_{SP}	0	$1 (4) \times t_{IICcyc}$	ns	
	SDA input bus free time (When wakeup function is disabled)	t_{BUF}	$3 (6) \times t_{IICcyc} + 300$	-	ns	
	SDA input bus free time (When wakeup function is enabled)	t_{BUF}	$3 (6) \times t_{IICcyc} + 4 \times t_{Pcyc} + 300$	-	ns	
	START condition input hold time (When wakeup function is disabled)	t_{STAH}	$t_{IICcyc} + 300$	-	ns	
	START condition input hold time (When wakeup function is enabled)	t_{STAH}	$1(5) \times t_{IICcyc} + t_{Pcyc} + 300$	-	ns	
	Repeated START condition input setup time	t_{STAS}	300	-	ns	
	STOP condition input setup time	t_{STOS}	300	-	ns	
	Data input setup time	t_{SDAS}	$t_{IICcyc} + 50$	-	ns	
	Data input hold time	t_{SDAH}	0	-	ns	
SCL, SDA capacitive load	C_b	-	400	pF		

Note: t_{IICcyc} : IIC internal reference clock (IIC ϕ) cycle, t_{Pcyc} : PCLKB cycle

Note 1. The value in parentheses apply when ICMR3.NF[1:0] is set to 11b while the digital filter is enabled with ICFER.NFE set to 1.

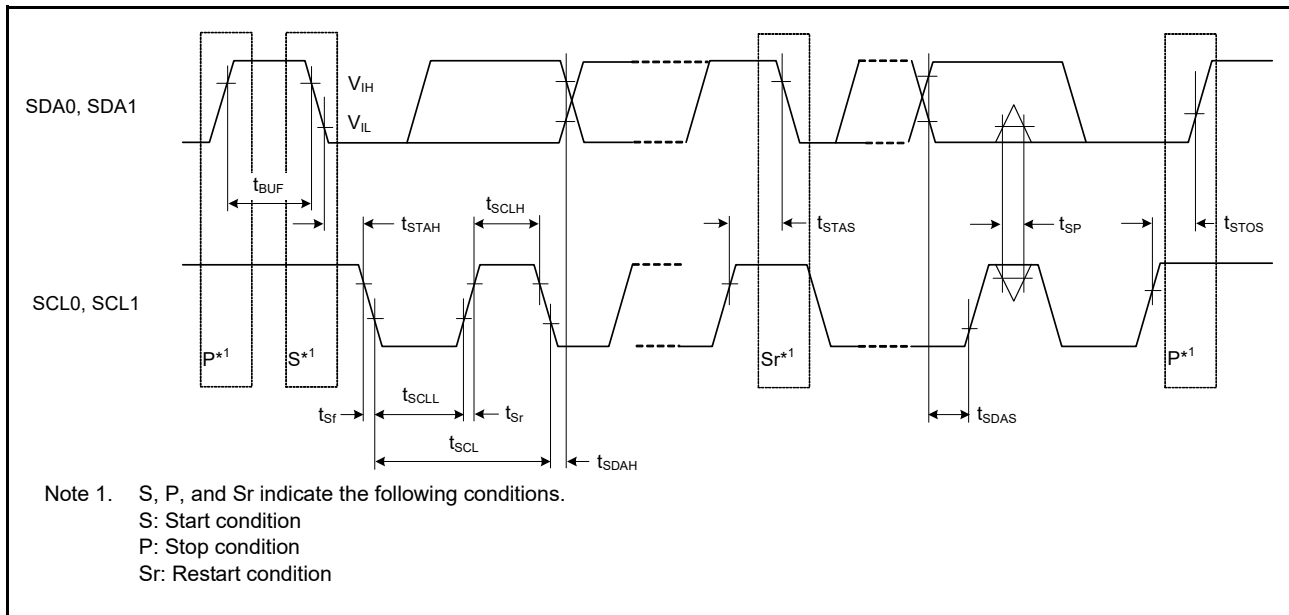

Figure 2.57 I2C bus interface input/output timing

2.3.11 CLKOUT Timing

Table 2.39 CLKOUT timing

Parameter		Symbol	Min	Max	Unit*1	Test conditions	
CLKOUT	CLKOUT pin output cycle*1	VCC = 2.7 V or above	t _{Cyc}	62.5	-	ns	Figure 2.58
		VCC = 1.8 V or above		125	-		
	CLKOUT pin high pulse width*2	VCC = 2.7 V or above	t _{CH}	15	-	ns	
		VCC = 1.8 V or above		30	-		
	CLKOUT pin low pulse width*2	VCC = 2.7 V or above	t _{CL}	15	-	ns	
		VCC = 1.8 V or above		30	-		
CLKOUT pin output rise time	VCC = 2.7 V or above	t _{Cr}	-	12	ns		
	VCC = 1.8 V or above		-	25			
CLKOUT pin output fall time	VCC = 2.7 V or above	t _{Cf}	-	12	ns		
	VCC = 1.8 V or above		-	25			
CLKOUT_RF*3	CLKOUT_RF pin output cycle	t _{CRF_{cyc}}	250	-	ns	Figure 2.59	
	CLKOUT_RF pin high pulse width	t _{CRFH}	100	-	ns		
	CLKOUT_RF pin low pulse width	t _{CRFL}	100	-	ns		
	CLKOUT_RF pin output rise time	t _{CRFr}	-	5	ns		
	CLKOUT_RF pin output fall time	t _{CRFf}	-	5	ns		

Note 1. When the EXTAL external clock input or an oscillator is used with division by 1 (the CKOCR.CKOSEL[2:0] bits are 011b and the CKOCR.CKODIV[2:0] bits are 000b) to output from CLKOUT, the above should be satisfied with an input duty cycle of 45 to 55%.

Note 2. When the MOCO is selected as the clock output source (the CKOCR.CKOSEL[2:0] bits are 001b), set the clock output division ratio selection to be divided by 2 (the CKOCR.CKODIV[2:0] bits are 001b).

Note 3. The voltage for VCC_RF when CLKOUT_RF pin is to be used is between 3.0 V and 3.6 V.

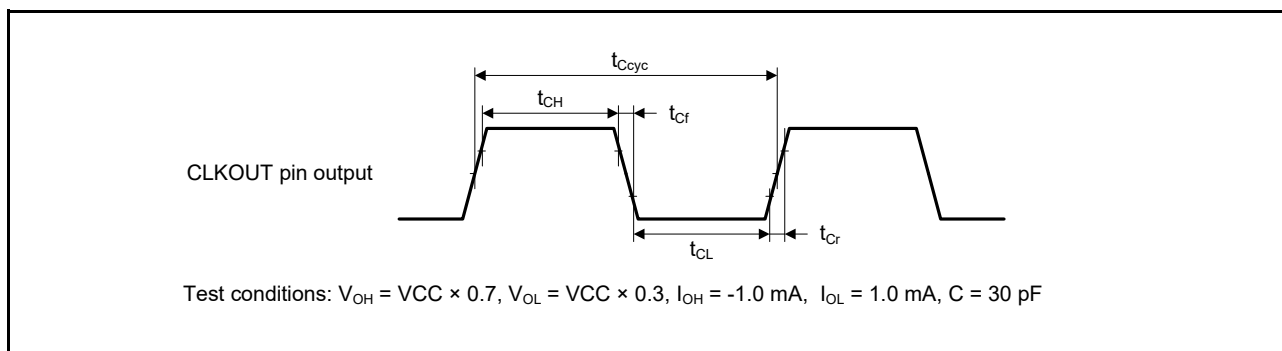

Figure 2.58 CLKOUT output timing

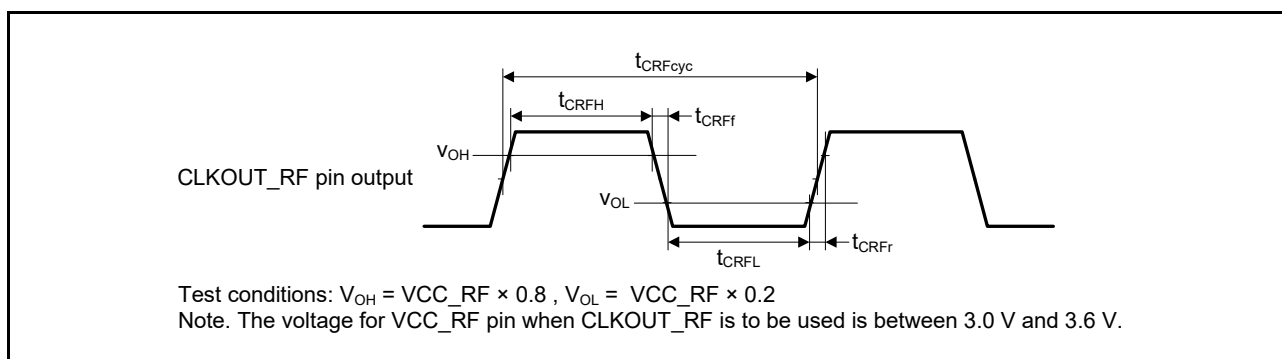

Figure 2.59 CLKOUT_RF Output Timing

2.4 USB Characteristics

2.4.1 USBFS Timing

Table 2.40 USB characteristics

Conditions: VCC = VCC_USB = 3.0 to 3.6 V, Ta = -20 to +85°C (USBCLKSEL = 1)

Parameter		Symbol	Min	Max	Unit	Test conditions	
Input characteristics	Input high level voltage	V_{IH}	2.0	-	V	-	
	Input low level voltage	V_{IL}	-	0.8	V	-	
	Differential input sensitivity	V_{DI}	0.2	-	V	USB_DP - USB_DM	
	Differential common mode range	V_{CM}	0.8	2.5	V	-	
Output characteristics	Output high level voltage	V_{OH}	2.8	VCC_USB	V	$I_{OH} = -200 \mu A$	
	Output low level voltage	V_{OL}	0.0	0.3	V	$I_{OL} = 2 \text{ mA}$	
	Cross-over voltage	V_{CRS}	1.3	2.0	V	Figure 2.60, Figure 2.61, Figure 2.62	
	Rise time	FS	t_r	4	20		ns
		LS		75	300		
	Fall time	FS	t_f	4	20		ns
		LS		75	300		
	Rise/fall time ratio	FS	t_r/t_f	90	111.11		%
LS		80		125			
Output resistance	Z_{DRV}	28	44	Ω	(Adjusting the resistance of external elements is not required.)		
VBUS characteristics	VBUS input voltage	V_{IH}	$VCC \times 0.8$	-	V	-	
		V_{IL}	-	$VCC \times 0.2$	V	-	
Pull-up, pull-down	Pull-down resistor	R_{PD}	14.25	24.80	k Ω	-	
	Pull-up resistor	R_{PUI}	0.9	1.575	k Ω	During idle state	
		R_{PUA}	1.425	3.09	k Ω	During reception	
Battery Charging Specification Ver 1.2	D + sink current	I_{DP_SINK}	25	175	μA	-	
	D - sink current	I_{DM_SINK}	25	175	μA	-	
	DCD source current	I_{DP_SRC}	7	13	μA	-	
	Data detection voltage	V_{DAT_REF}	0.25	0.4	V	-	
	D + source voltage	V_{DP_SRC}	0.5	0.7	V	Output current = 250 μA	
	D - source voltage	V_{DM_SRC}	0.5	0.7	V	Output current = 250 μA	

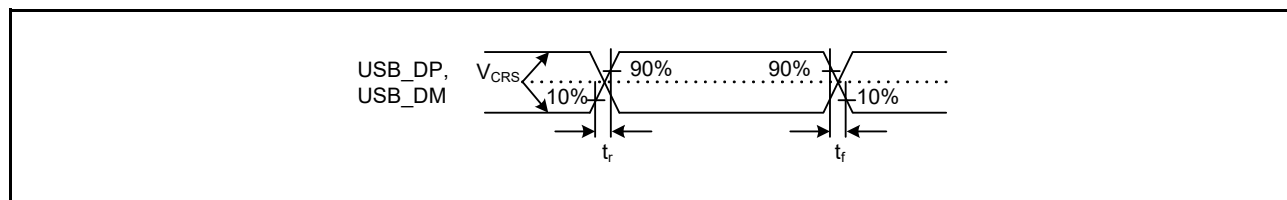

Figure 2.60 USB_DP and USB_DM output timing

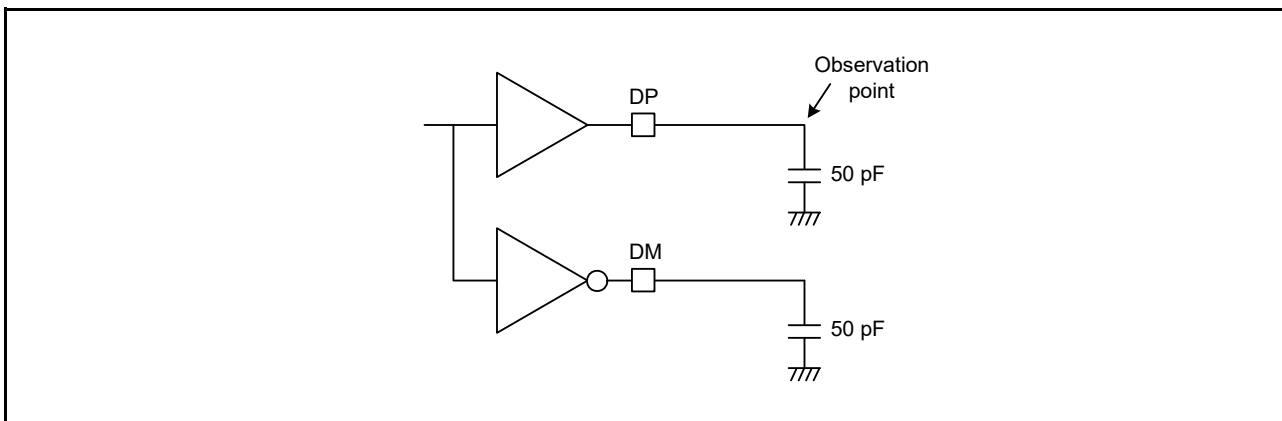

Figure 2.61 Test circuit for Full-Speed (FS) connection

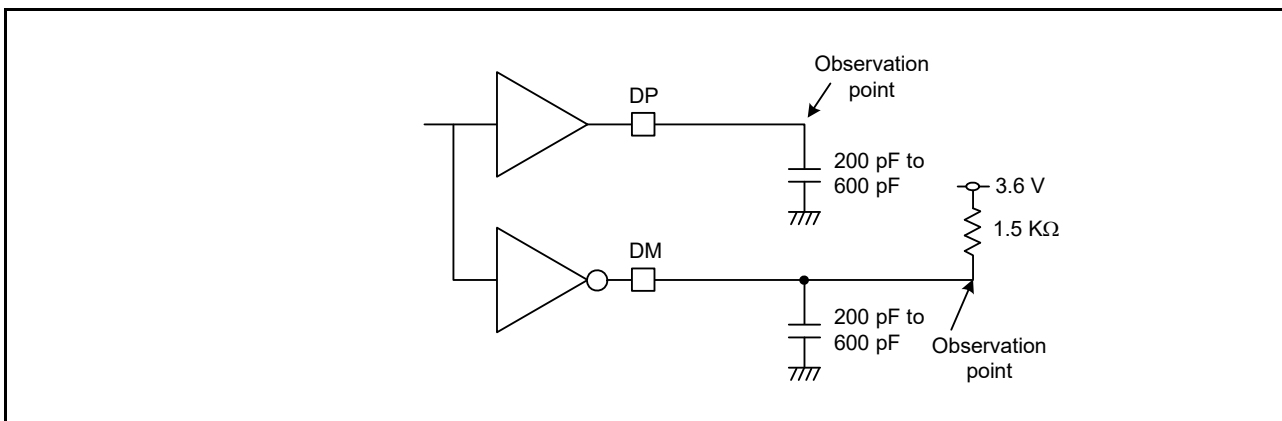

Figure 2.62 Test circuit for Low-Speed (LS) connection

2.5 ADC14 Characteristics

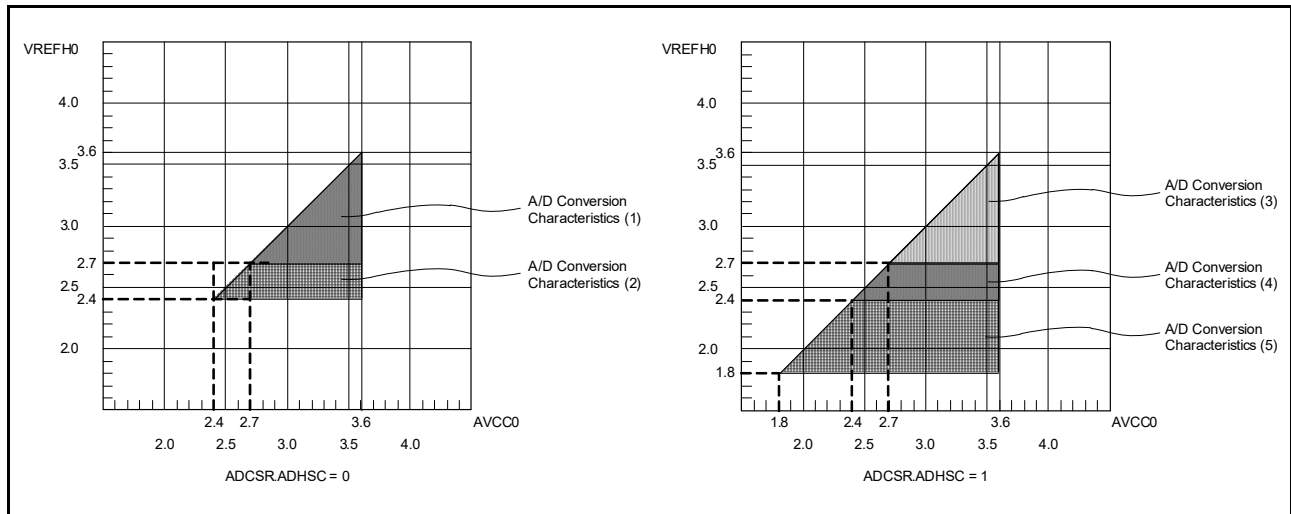

Figure 2.63 AVCC0 to VREFH0 voltage range

Table 2.41 A/D conversion characteristics (1) in high-speed A/D conversion mode (1 of 2)

Conditions: VCC = AVCC0 = 2.7 to 3.6 V, VREFH0 = 2.7 to 3.6 V
Reference voltage range applied to the VREFH0 and VREFL0.

Parameter	Min	Typ	Max	Unit	Test conditions	
Frequency	1	-	48	MHz	-	
Analog input capacitance*2	Cs	-	8 (reference data)	pF	High-precision channel	
		-	9 (reference data)	pF	Normal-precision channel	
Analog input resistance	Rs	-	2.5 (reference data)	kΩ	High-precision channel	
		-	6.7 (reference data)	kΩ	Normal-precision channel	
Analog input voltage range	Ain	0	VREFH0	V	-	
12-bit mode						
Resolution	-	-	12	Bit	-	
Conversion time*1 (Operation at PCLKC = 48 MHz)	Permissible signal source impedance Max. = 0.3 kΩ	0.94	-	-	μs	High-precision channel ADCSR.ADHSC = 0 ADSSTRn.SST[7:0] = 0Dh
		1.50	-	-	μs	Normal-precision channel ADCSR.ADHSC = 0 ADSSTRn.SST[7:0] = 28h
Offset error	-	±0.5	±4.5	LSB	High-precision channel	
			±6.0	LSB	Other than above	
Full-scale error	-	±0.75	±4.5	LSB	High-precision channel	
			±6.0	LSB	Other than above	
Quantization error	-	±0.5	-	LSB	-	
Absolute accuracy	-	±1.25	±5.0	LSB	High-precision channel	
			±8.0	LSB	Other than above	
DNL differential nonlinearity error	-	±1.0	-	LSB	-	
INL integral nonlinearity error	-	±1.0	±3.0	LSB	-	
14-bit mode						
Resolution	-	-	14	Bit	-	

Table 2.41 A/D conversion characteristics (1) in high-speed A/D conversion mode (2 of 2)

Conditions: VCC = AVCC0 = 2.7 to 3.6 V, VREFH0 = 2.7 to 3.6 V
Reference voltage range applied to the VREFH0 and VREFL0.

Parameter		Min	Typ	Max	Unit	Test conditions
Conversion time*1 (Operation at PCLKC = 48 MHz)	Permissible signal source impedance Max. = 0.3 kΩ	1.06	-	-	μs	High-precision channel ADCSR.ADHSC = 0 ADSSTRn.SST[7:0] = 0Dh
		1.63	-	-	μs	Normal-precision channel ADCSR.ADHSC = 0 ADSSTRn.SST[7:0] = 28h
Offset error		-	±2.0	±18	LSB	High-precision channel
				±24.0	LSB	Other than above
Full-scale error		-	±3.0	±18	LSB	High-precision channel
				±24.0	LSB	Other than above
Quantization error		-	±0.5	-	LSB	-
Absolute accuracy		-	±5.0	±20	LSB	High-precision channel
				±32.0	LSB	Other than above
DNL differential nonlinearity error		-	±4.0	-	LSB	-
INL integral nonlinearity error		-	±4.0	±12.0	LSB	-

Note: The characteristics apply when no pin functions other than 14-bit A/D converter input are used. Absolute accuracy does not include quantization errors. Offset error, full-scale error, DNL differential nonlinearity error, and INL integral nonlinearity error do not include quantization errors.

Note 1. The conversion time is the sum of the sampling time and the comparison time. The number of sampling states is indicated for the test conditions.

Note 2. Except for I/O input capacitance (Cin), see [section 2.2.4, I/O V_{OH}, V_{OL}, and Other Characteristics](#).

Table 2.42 A/D conversion characteristics (2) in high-speed A/D conversion mode (1 of 2)

Conditions: VCC = AVCC0 = 2.4 to 3.6 V, VREFH0 = 2.4 to 3.6 V
Reference voltage range applied to the VREFH0 and VREFL0.

Parameter		Min	Typ	Max	Unit	Test conditions
Frequency		1	-	32	MHz	-
Analog input capacitance*2	Cs	-	-	8 (reference data)	pF	High-precision channel
		-	-	9 (reference data)	pF	Normal-precision channel
Analog input resistance	Rs	-	-	2.5 (reference data)	kΩ	High-precision channel
		-	-	6.7 (reference data)	kΩ	Normal-precision channel
Analog input voltage range	Ain	0	-	VREFH0	V	-
12-bit mode						
Resolution		-	-	12	Bit	-
Conversion time*1 (Operation at PCLKC = 32 MHz)	Permissible signal source impedance Max. = 1.3 kΩ	1.41	-	-	μs	High-precision channel ADCSR.ADHSC = 0 ADSSTRn.SST[7:0] = 0Dh
		2.25	-	-	μs	Normal-precision channel ADCSR.ADHSC = 0 ADSSTRn.SST[7:0] = 28h
Offset error		-	±0.5	±4.5	LSB	High-precision channel
				±6.0	LSB	Other than above
Full-scale error		-	±0.75	±4.5	LSB	High-precision channel
				±6.0	LSB	Other than above
Quantization error		-	±0.5	-	LSB	-
Absolute accuracy		-	±1.25	±5.0	LSB	High-precision channel
				±8.0	LSB	Other than above
DNL differential nonlinearity error		-	±1.0	-	LSB	-
INL integral nonlinearity error		-	±1.0	±3.0	LSB	-
14-bit mode						

Table 2.42 A/D conversion characteristics (2) in high-speed A/D conversion mode (2 of 2)

Conditions: VCC = AVCC0 = 2.4 to 3.6 V, VREFH0 = 2.4 to 3.6 V
Reference voltage range applied to the VREFH0 and VREFL0.

Parameter	Min	Typ	Max	Unit	Test conditions	
Resolution	-	-	14	Bit	-	
Conversion time*1 (Operation at PCLKC = 32 MHz)	Permissible signal source impedance Max. = 1.3 kΩ	1.59	-	-	μs	High-precision channel ADCSR.ADHSC = 0 ADSSTRn.SST[7:0] = 0Dh
		2.44	-	-	μs	Normal-precision channel ADCSR.ADHSC = 0 ADSSTRn.SST[7:0] = 28h
Offset error		±2.0	±18	LSB	High-precision channel	
			±24.0	LSB	Other than above	
Full-scale error		±3.0	±18	LSB	High-precision channel	
			±24.0	LSB	Other than above	
Quantization error		±0.5	-	LSB	-	
Absolute accuracy		±5.0	±20	LSB	High-precision channel	
			±32.0	LSB	Other than above	
DNL differential nonlinearity error		±4.0	-	LSB	-	
INL integral nonlinearity error		±4.0	±12.0	LSB	-	

Note: The characteristics apply when no pin functions other than 14-bit A/D converter input are used. Absolute accuracy does not include quantization errors. Offset error, full-scale error, DNL differential nonlinearity error, and INL integral nonlinearity error do not include quantization errors.

Note 1. The conversion time is the sum of the sampling time and the comparison time. The number of sampling states is indicated for the test conditions.

Note 2. Except for I/O input capacitance (Cin), see [section 2.2.4, I/O V_{OH}, V_{OL}, and Other Characteristics](#).

Table 2.43 A/D conversion characteristics (3) in low power A/D conversion mode (1 of 2)

Conditions: VCC = AVCC0 = 2.7 to 3.6 V, VREFH0 = 2.7 to 3.6 V
Reference voltage range applied to the VREFH0 and VREFL0.

Parameter	Min	Typ	Max	Unit	Test conditions	
Frequency	1	-	24	MHz	-	
Analog input capacitance*2	Cs	-	-	8 (reference data)	pF	High-precision channel
		-	-	9 (reference data)	pF	Normal-precision channel
Analog input resistance	Rs	-	-	2.5 (reference data)	kΩ	High-precision channel
		-	-	6.7 (reference data)	kΩ	Normal-precision channel
Analog input voltage range	Ain	0	-	VREFH0	V	-
12-bit mode						
Resolution	-	-	12	Bit	-	
Conversion time*1 (Operation at PCLKC = 24 MHz)	Permissible signal source impedance Max. = 1.1 kΩ	2.25	-	-	μs	High-precision channel ADCSR.ADHSC = 1 ADSSTRn.SST[7:0] = 0Dh
		3.38	-	-	μs	Normal-precision channel ADCSR.ADHSC = 1 ADSSTRn.SST[7:0] = 28h
Offset error		±0.5	±4.5	LSB	High-precision channel	
			±6.0	LSB	Other than above	
Full-scale error		±0.75	±4.5	LSB	High-precision channel	
			±6.0	LSB	Other than above	
Quantization error		±0.5	-	LSB	-	
Absolute accuracy		±1.25	±5.0	LSB	High-precision channel	
			±8.0	LSB	Other than above	
DNL differential nonlinearity error		±1.0	-	LSB	-	
INL integral nonlinearity error		±1.0	±3.0	LSB	-	

Table 2.43 A/D conversion characteristics (3) in low power A/D conversion mode (2 of 2)

Conditions: VCC = AVCC0 = 2.7 to 3.6 V, VREFH0 = 2.7 to 3.6 V
Reference voltage range applied to the VREFH0 and VREFL0.

Parameter		Min	Typ	Max	Unit	Test conditions
14-bit mode						
Resolution		-	-	14	Bit	-
Conversion time*1 (Operation at PCLKC = 24 MHz)	Permissible signal source impedance Max. = 1.1 kΩ	2.50	-	-	μs	High-precision channel ADCSR.ADHSC = 1 ADSSTRn.SST[7:0] = 0Dh
		3.63	-	-	μs	Normal-precision channel ADCSR.ADHSC = 1 ADSSTRn.SST[7:0] = 28h
Offset error		-	±2.0	±18	LSB	High-precision channel
				±24.0	LSB	Other than above
Full-scale error		-	±3.0	±18	LSB	High-precision channel
				±24.0	LSB	Other than above
Quantization error		-	±0.5	-	LSB	-
Absolute accuracy		-	±5.0	±20	LSB	High-precision channel
				±32.0	LSB	Other than above
DNL differential nonlinearity error		-	±4.0	-	LSB	-
INL integral nonlinearity error		-	±4.0	±12.0	LSB	-

Note: The characteristics apply when no pin functions other than 14-bit A/D converter input are used. Absolute accuracy does not include quantization errors. Offset error, full-scale error, DNL differential nonlinearity error, and INL integral nonlinearity error do not include quantization errors.

Note 1. The conversion time is the sum of the sampling time and the comparison time. The number of sampling states is indicated for the test conditions.

Note 2. Except for I/O input capacitance (Cin), see [section 2.2.4, I/O V_{OH}, V_{OL}, and Other Characteristics](#).

Table 2.44 A/D conversion characteristics (4) in low power A/D conversion mode (1 of 2)

Conditions: VCC = AVCC0 = 2.4 to 3.6 V, VREFH0 = 2.4 to 3.6 V
Reference voltage range applied to the VREFH0 and VREFL0.

Parameter		Min	Typ	Max	Unit	Test conditions
Frequency		1	-	16	MHz	-
Analog input capacitance*2	Cs	-	-	8 (reference data)	pF	High-precision channel
		-	-	9 (reference data)	pF	Normal-precision channel
Analog input resistance	Rs	-	-	2.5 (reference data)	kΩ	High-precision channel
		-	-	6.7 (reference data)	kΩ	Normal-precision channel
Analog input voltage range	Ain	0	-	VREFH0	V	-
12-bit mode						
Resolution		-	-	12	Bit	-
Conversion time*1 (Operation at PCLKC = 16 MHz)	Permissible signal source impedance Max. = 2.2 kΩ	3.38	-	-	μs	High-precision channel ADCSR.ADHSC = 1 ADSSTRn.SST[7:0] = 0Dh
		5.06	-	-	μs	Normal-precision channel ADCSR.ADHSC = 1 ADSSTRn.SST[7:0] = 28h
Offset error		-	±0.5	±4.5	LSB	High-precision channel
				±6.0	LSB	Other than above
Full-scale error		-	±0.75	±4.5	LSB	High-precision channel
				±6.0	LSB	Other than above
Quantization error		-	±0.5	-	LSB	-
Absolute accuracy		-	±1.25	±5.0	LSB	High-precision channel
				±8.0	LSB	Other than above
DNL differential nonlinearity error		-	±1.0	-	LSB	-

Table 2.44 A/D conversion characteristics (4) in low power A/D conversion mode (2 of 2)

Conditions: VCC = AVCC0 = 2.4 to 3.6 V, VREFH0 = 2.4 to 3.6 V
Reference voltage range applied to the VREFH0 and VREFL0.

Parameter	Min	Typ	Max	Unit	Test conditions	
INL integral nonlinearity error	-	±1.0	±3.0	LSB	-	
14-bit mode						
Resolution	-	-	14	Bit	-	
Conversion time*1 (Operation at PCLKC = 16 MHz)	Permissible signal source impedance Max. = 2.2 kΩ	3.75	-	-	μs	High-precision channel ADCSR.ADHSC = 1 ADSSTRn.SST[7:0] = 0Dh
		5.44	-	-	μs	Normal-precision channel ADCSR.ADHSC = 1 ADSSTRn.SST[7:0] = 28h
Offset error		±2.0	±18	LSB	High-precision channel	
			±24.0	LSB	Other than above	
Full-scale error		±3.0	±18	LSB	High-precision channel	
			±24.0	LSB	Other than above	
Quantization error		±0.5	-	LSB	-	
Absolute accuracy		±5.0	±20	LSB	High-precision channel	
			±32.0	LSB	Other than above	
DNL differential nonlinearity error		±4.0	-	LSB	-	
INL integral nonlinearity error		±4.0	±12.0	LSB	-	

Note: The characteristics apply when no pin functions other than 14-bit A/D converter input are used. Absolute accuracy does not include quantization errors. Offset error, full-scale error, DNL differential nonlinearity error, and INL integral nonlinearity error do not include quantization errors.

Note 1. The conversion time is the sum of the sampling time and the comparison time. The number of sampling states is indicated for the test conditions.

Note 2. Except for I/O input capacitance (Cin), see [section 2.2.4, I/O V_{OH}, V_{OL}, and Other Characteristics](#).

Table 2.45 A/D conversion characteristics (5) in low power A/D conversion mode (1 of 2)

Conditions: VCC = AVCC0 = 1.8 to 3.6 V (AVCC0 = VCC when VCC < 2.0 V), VREFH0 = 1.8 to 3.6 V
Reference voltage range applied to the VREFH0 and VREFL0.

Parameter	Min	Typ	Max	Unit	Test conditions	
Frequency	1	-	8	MHz	-	
Analog input capacitance*2	Cs	-	8 (reference data)	pF	High-precision channel	
		-	9 (reference data)	pF	Normal-precision channel	
Analog input resistance	Rs	-	3.8 (reference data)	kΩ	High-precision channel	
		-	8.2 (reference data)	kΩ	Normal-precision channel	
Analog input voltage range	Ain	0	VREFH0	V	-	
12-bit mode						
Resolution	-	-	12	Bit	-	
Conversion time*1 (Operation at PCLKC = 8 MHz)	Permissible signal source impedance Max. = 5 kΩ	6.75	-	-	μs	High-precision channel ADCSR.ADHSC = 1 ADSSTRn.SST[7:0] = 0Dh
		10.13	-	-	μs	Normal-precision channel ADCSR.ADHSC = 1 ADSSTRn.SST[7:0] = 28h
Offset error		±1.0	±7.5	LSB	High-precision channel	
			±10.0	LSB	Other than above	
Full-scale error		±1.5	±7.5	LSB	High-precision channel	
			±10.0	LSB	Other than above	
Quantization error		±0.5	-	LSB	-	
Absolute accuracy		±3.0	±8.0	LSB	High-precision channel	
			±12.0	LSB	Other than above	

Table 2.45 A/D conversion characteristics (5) in low power A/D conversion mode (2 of 2)

Conditions: VCC = AVCC0 = 1.8 to 3.6 V (AVCC0 = VCC when VCC < 2.0 V), VREFH0 = 1.8 to 3.6 V
Reference voltage range applied to the VREFH0 and VREFL0.

Parameter	Min	Typ	Max	Unit	Test conditions	
DNL differential nonlinearity error	-	±1.0	-	LSB	-	
INL integral nonlinearity error	-	±1.0	±3.0	LSB	-	
14-bit mode						
Resolution	-	-	14	Bit	-	
Conversion time*1 (Operation at PCLKC = 8 MHz)	Permissible signal source impedance Max. = 5 kΩ	7.50	-	-	μs	High-precision channel ADCSR.ADHSC = 1 ADSSTRn.SST[7:0] = 0Dh
		10.88	-	-	μs	Normal-precision channel ADCSR.ADHSC = 1 ADSSTRn.SST[7:0] = 28h
Offset error		±4.0	±30.0	LSB	High-precision channel	
			±40.0	LSB	Other than above	
Full-scale error		±6.0	±30.0	LSB	High-precision channel	
			±40.0	LSB	Other than above	
Quantization error		±0.5	-	LSB	-	
Absolute accuracy		±12.0	±32.0	LSB	High-precision channel	
			±48.0	LSB	Other than above	
DNL differential nonlinearity error	-	±4.0	-	LSB	-	
INL integral nonlinearity error	-	±4.0	±12.0	LSB	-	

Note: The characteristics apply when no pin functions other than 14-bit A/D converter input are used. Absolute accuracy does not include quantization errors. Offset error, full-scale error, DNL differential nonlinearity error, and INL integral nonlinearity error do not include quantization errors.

Note 1. The conversion time is the sum of the sampling time and the comparison time. The number of sampling states is indicated for the test conditions.

Note 2. Except for I/O input capacitance (Cin), see section 2.2.4, I/O VOH, VOL, and Other Characteristics.

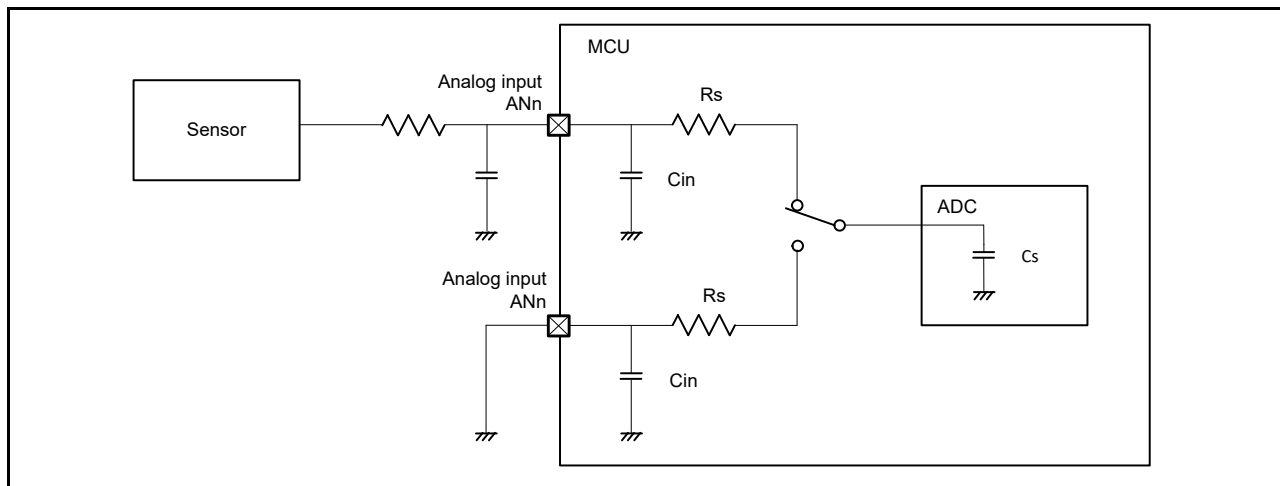

Figure 2.64 Equivalent circuit for analog input

Table 2.46 14-bit A/D converter channel classification (1 of 2)

Classification	Channel	Conditions	Remarks
High-precision channel	AN004 to AN006, AN009, AN010	AVCC0 = 1.8 to 3.6 V	Pins AN004 to AN006, AN009 and AN010 cannot be used as general I/O, IRQ3 inputs, and TS transmission, when the A/D converter is in use
Normal-precision channel	AN017, AN019, AN020		
Internal reference voltage input channel	Internal reference voltage	AVCC0 = 2.0 to 3.6 V	-

Table 2.46 14-bit A/D converter channel classification (2 of 2)

Classification	Channel	Conditions	Remarks
Temperature sensor input channel	Temperature sensor output	AVCC0 = 2.0 to 3.6 V	-

Table 2.47 A/D internal reference voltage characteristics

Conditions: VCC = AVCC0 = VREFH0 = 2.0 to 3.6 V*1

Parameter	Min	Typ	Max	Unit	Test conditions
Internal reference voltage input channel*2	1.36	1.43	1.50	V	-
Frequency*3	1	-	2	MHz	-
Sampling time*4	5.0	-	-	μs	-

Note 1. The internal reference voltage cannot be selected for input channels when AVCC0 < 2.0 V.

Note 2. The 14-bit A/D internal reference voltage indicates the voltage when the internal reference voltage is input to the 14-bit A/D converter.

Note 3. This is a parameter for ADC14 when the internal reference voltage is used as a high-potential reference voltage.

Note 4. This is a parameter for ADC14 when the internal reference voltage is selected for an analog input channel in ADC14.

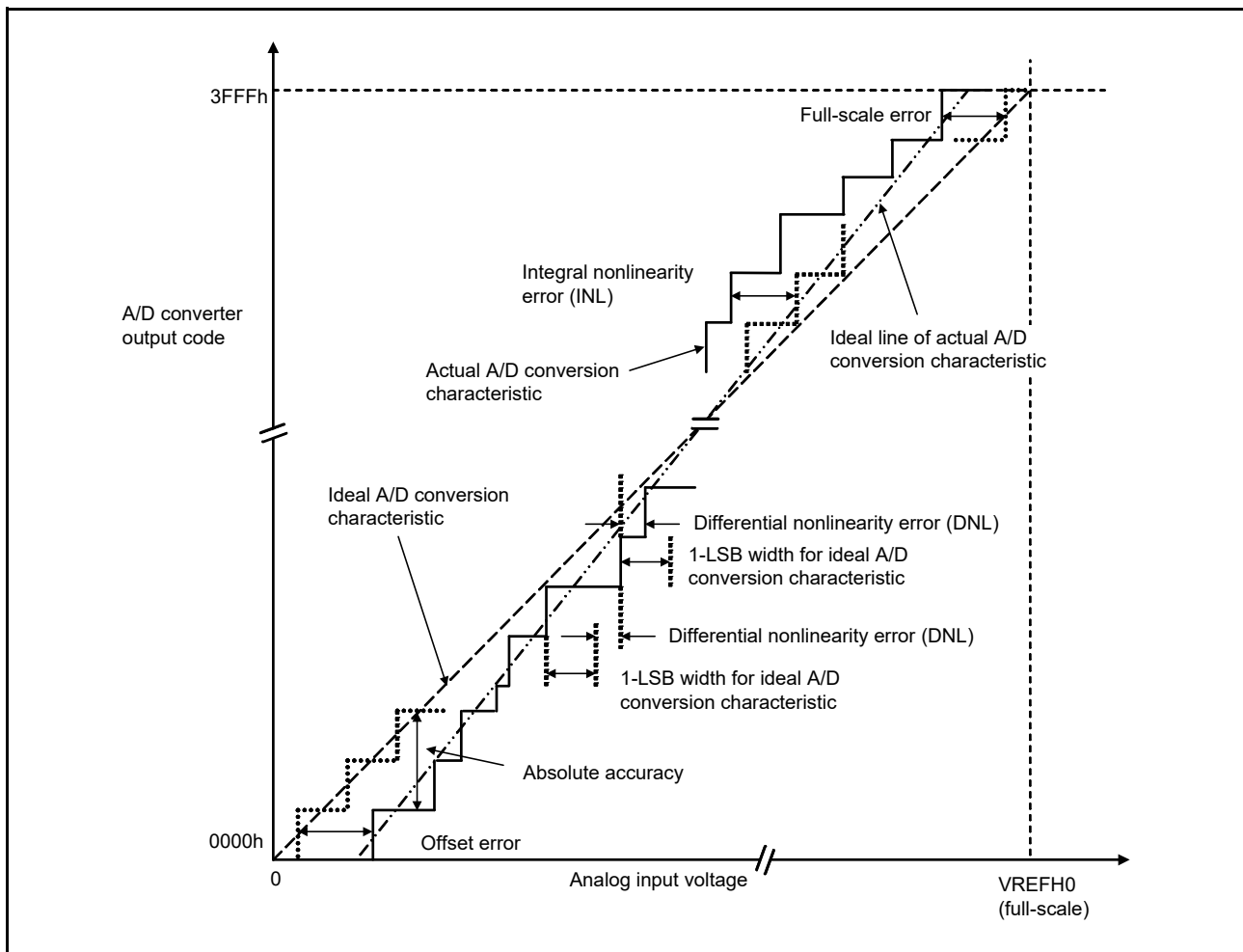

Figure 2.65 Illustration of 14-bit A/D converter characteristic terms

Absolute accuracy

Absolute accuracy is the difference between output code based on the theoretical A/D conversion characteristics, and the actual A/D conversion result. When measuring absolute accuracy, the voltage at the midpoint of the width of analog input voltage (1-LSB width), which can meet the expectation of outputting an equal code based on the theoretical A/D conversion characteristics, is used as the analog input voltage. For example, if 12-bit resolution is used and the reference voltage $V_{REFH0} = 3.072$ V, then 1-LSB width becomes 0.75 mV, and 0 mV, 0.75 mV, and 1.5 mV are used as the analog input voltages. If analog input voltage is 6 mV, an absolute accuracy of ± 5 LSB means that the actual A/D conversion result is in the range of 003h to 00Dh, though an output code of 008h can be expected from the theoretical A/D conversion characteristics.

Integral nonlinearity error (INL)

Integral nonlinearity error is the maximum deviation between the ideal line when the measured offset and full-scale errors are zeroed, and the actual output code.

Differential nonlinearity error (DNL)

Differential nonlinearity error is the difference between 1-LSB width based on the ideal A/D conversion characteristics and the width of the actually output code.

Offset error

Offset error is the difference between the transition point of the ideal first output code and the actual first output code.

Full-scale error

Full-scale error is the difference between the transition point of the ideal last output code and the actual last output code.

2.6 DAC12 Characteristics

Table 2.48 D/A conversion characteristics (1)

Conditions: VCC = AVCC0 = 1.8 to 3.6 V

Reference voltage = AVCC0 or AVSS0 selected

Parameter	Min	Typ	Max	Unit	Test conditions
Resolution	-	-	12	bit	-
Resistive load	30	-	-	kΩ	-
Capacitive load	-	-	50	pF	-
Output voltage range	0.35	-	AVCC0 – 0.47	V	-
DNL differential nonlinearity error	-	±0.5	±2.0	LSB	-
INL integral nonlinearity error	-	±2.0	±8.0	LSB	-
Offset error	-	-	±30	mV	-
Full-scale error	-	-	±30	mV	-
Output impedance	-	5	-	Ω	-
Conversion time	-	-	30	μs	-

Table 2.49 D/A conversion characteristics (2)

Conditions: VCC = AVCC0 = 1.8 to 3.6 V

Reference voltage = internal reference voltage selected

Parameter	Min	Typ	Max	Unit	Test conditions
Resolution	-	-	12	bit	-
Internal reference voltage (Vbgr)	1.36	1.43	1.50	V	-
Resistive load	30	-	-	kΩ	-
Capacitive load	-	-	50	pF	-
Output voltage range	0.35	-	Vbgr	V	-
DNL differential nonlinearity error	-	±2.0	±16.0	LSB	-
INL integral nonlinearity error	-	±8.0	±16.0	LSB	-
Offset error	-	-	±30	mV	-
Output impedance	-	5	-	Ω	-
Conversion time	-	-	30	μs	-

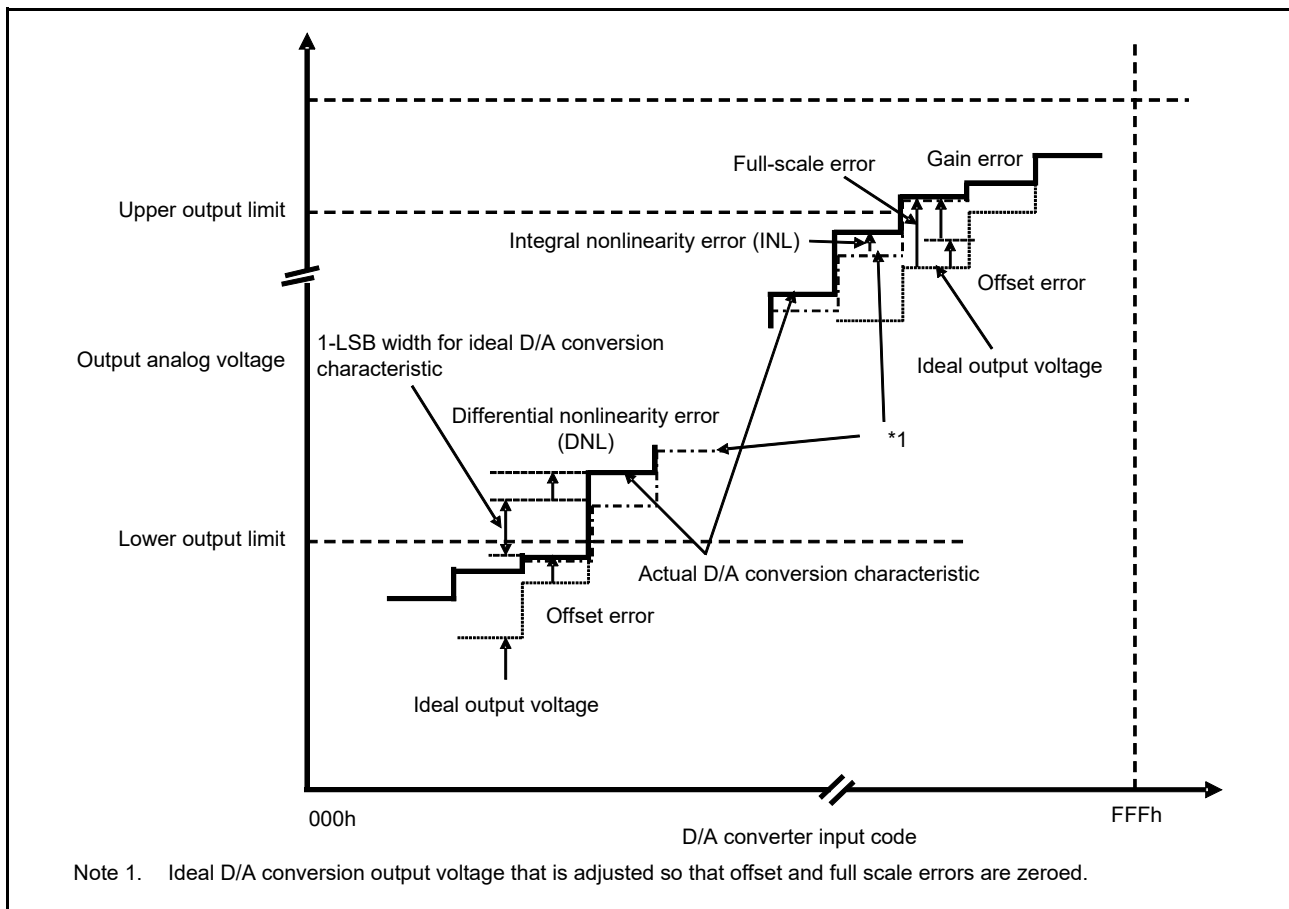

Figure 2.66 Illustration of D/A converter characteristic terms

Integral nonlinearity error (INL)

Integral nonlinearity error is the maximum deviation between the ideal output voltage based on the ideal conversion characteristic when the measured offset and full-scale errors are zeroed, and the actual output voltage.

Differential nonlinearity error (DNL)

Differential nonlinearity error is the difference between 1-LSB voltage width based on the ideal D/A conversion characteristics and the width of the actual output voltage.

Offset error

Offset error is the difference between the highest actual output voltage that falls below the lower output limit and the ideal output voltage based on the input code.

Full-scale error

Full-scale error is the difference between the lowest actual output voltage that exceeds the upper output limit and the ideal output voltage based on the input code.

2.7 TSN Characteristics

Table 2.50 TSN characteristics

Conditions: VCC = AVCC0 = 2.0 to 3.6 V

Parameter	Symbol	Min	Typ	Max	Unit	Test conditions
Relative accuracy	-	-	±1.5	-	°C	2.4 V or above
	-	-	±2.0	-	°C	Below 2.4 V
Temperature slope	-	-	-3.65	-	mV/°C	-
Output voltage (at 25°C)	-	-	1.05	-	V	VCC = 3.3 V
Temperature sensor start time	t _{START}	-	-	5	µs	-
Sampling time	-	5	-	-	µs	-

2.8 OSC Stop Detect Characteristics

Table 2.51 Oscillation stop detection circuit characteristics

Parameter	Symbol	Min	Typ	Max	Unit	Test conditions
Detection time	t _{dr}	-	-	1	ms	Figure 2.67

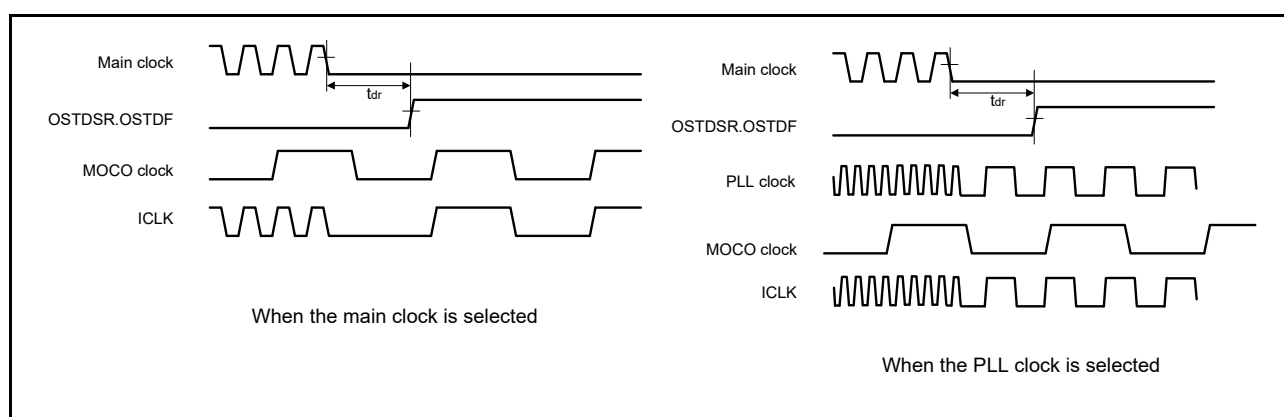

Figure 2.67 Oscillation stop detection timing

2.9 POR and LVD Characteristics

Table 2.52 Power-on reset circuit and voltage detection circuit characteristics (1)

Parameter		Symbol	Min	Typ	Max	Unit	Test conditions
Voltage detection level*1	Power-on reset (POR)	V _{POR}	1.27	1.42	1.57	V	Figure 2.68, Figure 2.69
	Voltage detection circuit (LVD0)*2	V _{det0_1}	2.68	2.85	2.96	V	Figure 2.70 At falling edge VCC
		V _{det0_2}	2.38	2.53	2.64		
		V _{det0_3}	1.78	1.90	2.02		
	Voltage detection circuit (LVD1)*3	V _{det1_4}	2.98	3.10	3.22	V	Figure 2.71 At falling edge VCC
		V _{det1_5}	2.89	3.00	3.11		
		V _{det1_6}	2.79	2.90	3.01		
		V _{det1_7}	2.68	2.79	2.90		
		V _{det1_8}	2.58	2.68	2.78		
		V _{det1_9}	2.48	2.58	2.68		
		V _{det1_A}	2.38	2.48	2.58		
		V _{det1_B}	2.10	2.20	2.30		
		V _{det1_C}	1.84	1.96	2.05		
		V _{det1_D}	1.74	1.86	1.95		
		V _{det1_E}	1.63	1.75	1.84		
V _{det1_F}	1.60	1.65	1.73				

Note 1. These characteristics apply when noise is not superimposed on the power supply.

Note 2. # in the symbol V_{det0_#} denotes the value of the OFS1.VDSEL1[2:0] bits.

Note 3. # in the symbol V_{det1_#} denotes the value of the LVDLVL.LVD1LVL[4:0] bits.

Table 2.53 Power-on reset circuit and voltage detection circuit characteristics (2)

Parameter	Symbol	Min	Typ	Max	Unit	Test conditions	
Wait time after power-on reset cancellation	LVD0:enable	t_{POR}	-	1.7	-	ms	-
	LVD0:disable	t_{POR}	-	1.3	-	ms	-
Wait time after voltage monitor 0,1 reset cancellation	LVD0:enable*1	$t_{LVD0,1}$	-	0.6	-	ms	-
	LVD0:disable*2	t_{LVD1}	-	0.2	-	ms	-
Response delay*3	t_{det}	-	-	350	μ s	Figure 2.68, Figure 2.69	
Minimum VCC down time	t_{VOFF}	450	-	-	μ s	Figure 2.68, VCC = 1.0 V or above	
Power-on reset enable time	t_W (POR)	1	-	-	ms	Figure 2.69, VCC = below 1.0 V	
LVD operation stabilization time (after LVD is enabled)	t_d (E-A)	-	-	300	μ s	Figure 2.71	
Hysteresis width (POR)	V_{PORH}	-	110	-	mV	-	
Hysteresis width (LVD0 and LVD1)	V_{LVH}	-	60	-	mV	LVD0 selected	
		-	60	-		V_{det1_4} to V_{det1_9} selected	
		-	50	-		V_{det1_A} or V_{det1_B} selected	
		-	40	-		V_{det1_C} or V_{det1_F} selected	

Note 1. When OFS1.LVDAS = 0.

Note 2. When OFS1.LVDAS = 1.

Note 3. The minimum VCC down time indicates the time when VCC is below the minimum value of voltage detection levels V_{POR} , V_{det0} and V_{det1} for the POR/LVD.

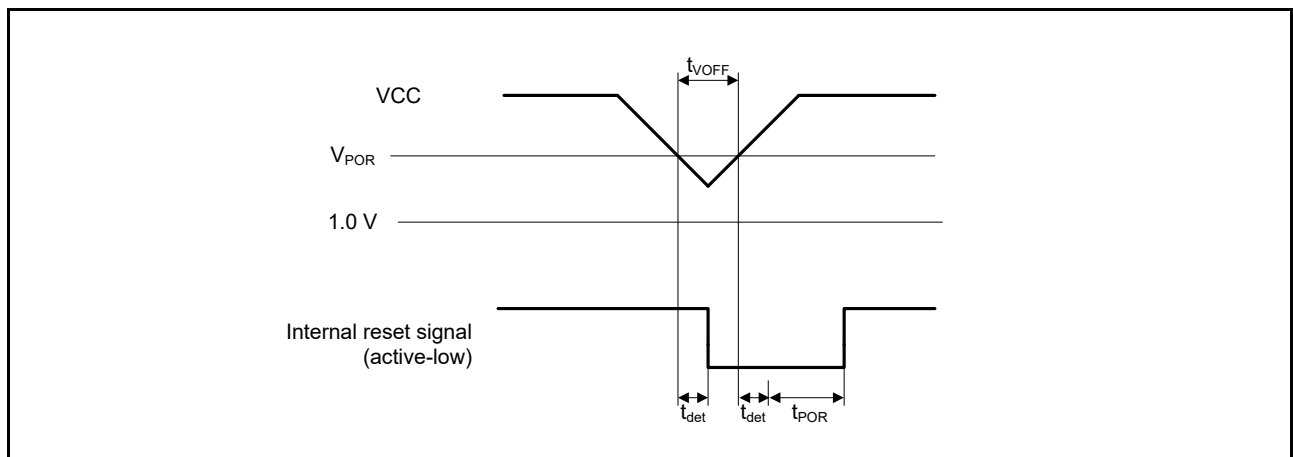

Figure 2.68 Voltage detection reset timing

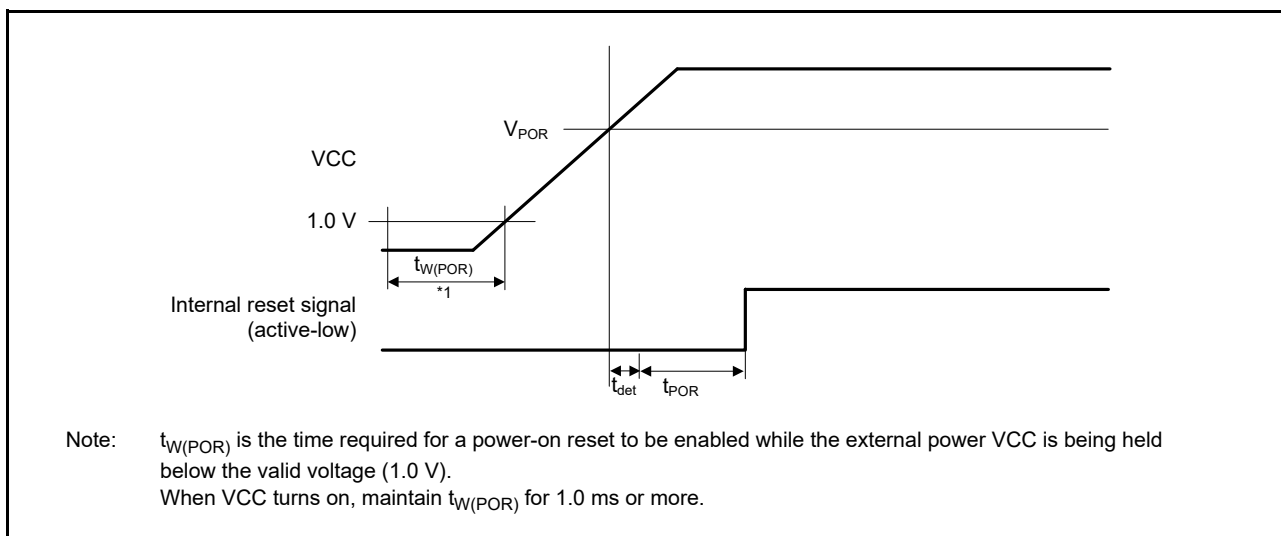

Figure 2.69 Power-on reset timing

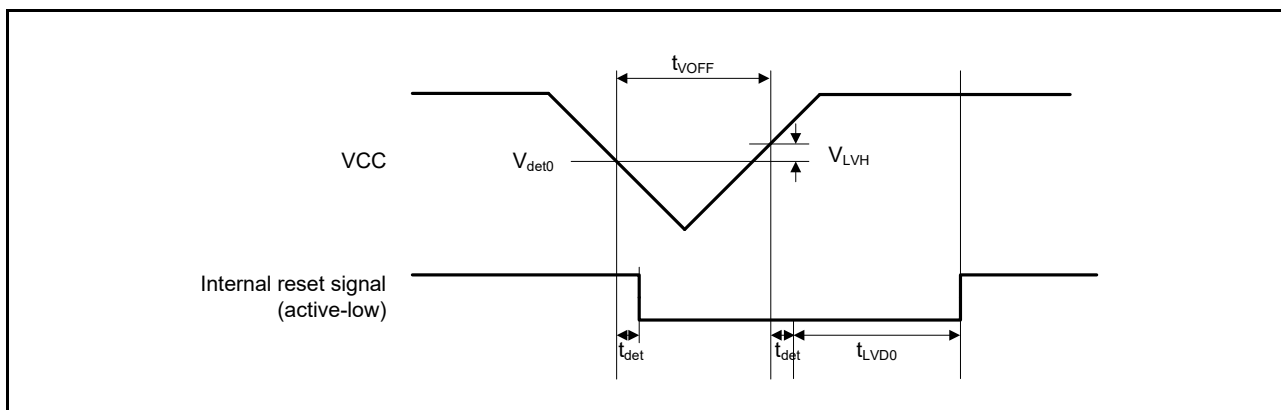

Figure 2.70 Voltage detection circuit timing (V_{det0})

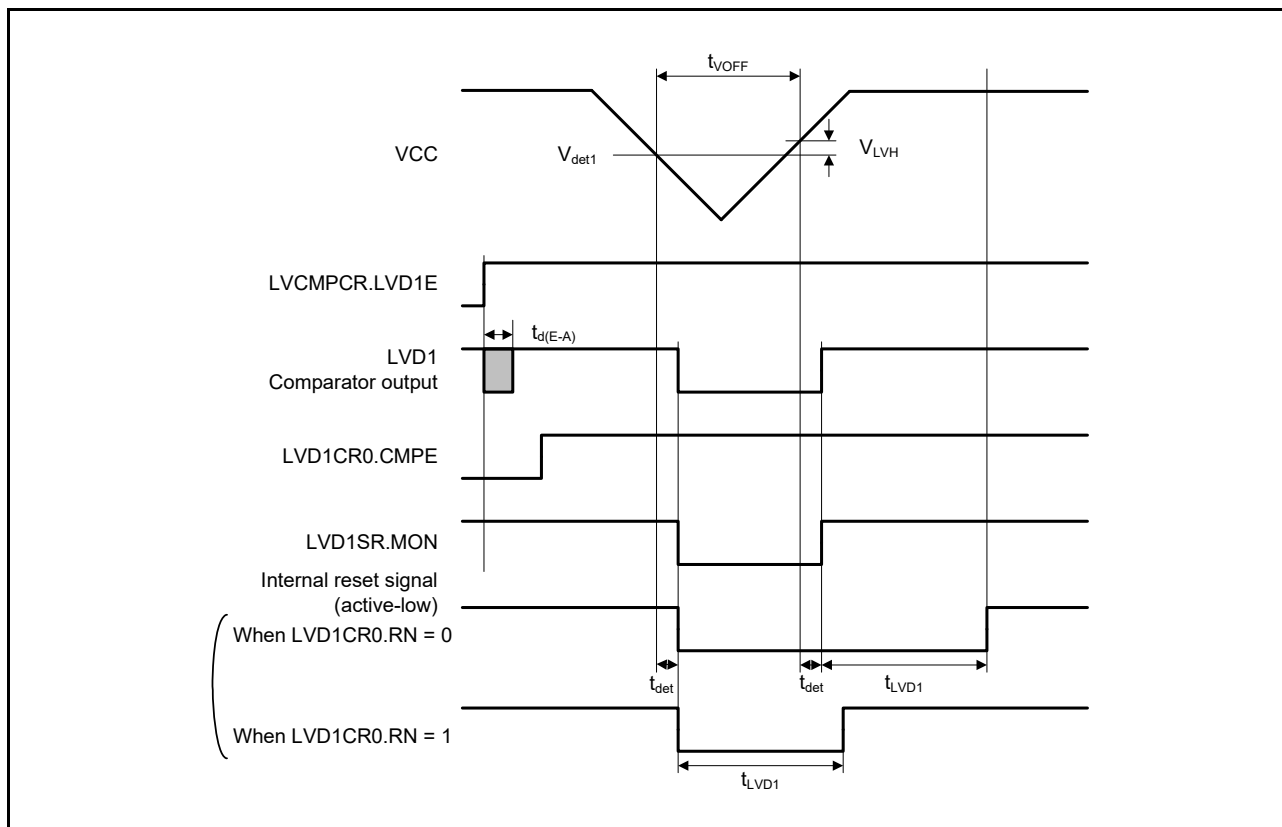

Figure 2.71 Voltage detection circuit timing (V_{det1})

2.10 VBATT Characteristics

Table 2.54 Battery backup function characteristics
 Conditions: VCC = AVCC0 = 1.8V to 3.6V, VBATT = 1.6 to 3.6 V

Parameter	Symbol	Min	Typ	Max	Unit	Test conditions	
Voltage level for switching to battery backup (falling)	$V_{DET\ BATT}$	1.99	2.09	2.19	V	Figure 2.72, Figure 2.73	
Hysteresis width for switching to battery back up	$V_{VBAT\ TH}$	-	100	-	mV		
VCC-off period for starting power supply switching	$t_{V\ OFF\ BATT}$	300	-	-	μs	-	
Voltage detection level VBATT_Power-on reset (VBATT_POR)	$V_{VBAT\ POR}$	1.30	1.40	1.50	V	Figure 2.72, Figure 2.73	
Wait time after VBATT_POR reset time cancellation	$t_{VBAT\ POR}$	-	-	3	mS	-	
Level for detection of voltage drop on the VBATT pin (falling)	$V_{DET\ BAT\ LVD}$	VBTLVDLVL[1:0] = 10b	2.11	2.2	2.29	V	Figure 2.74
		VBTLVDLVL[1:0] = 11b	1.92	2	2.08	V	
Hysteresis width for VBATT pin LVD	$V_{VBAT\ LVD\ TH}$	-	50	-	mV	-	
VBATT pin LVD operation stabilization time	t_{d_vbat}	-	-	300	μs	Figure 2.74	
VBATT pin LVD response delay time	t_{det_vbat}	-	-	350	μs	-	
Allowable voltage change rising/falling gradient	$dt/dVCC$	1.0	-	-	ms/V	-	
VCC voltage level for access to the VBATT backup registers	$V_{_BKBATT}$	1.8	-	-	V	-	

Note: The VCC-off period for starting power supply switching indicates the period in which VCC is below the minimum value of the voltage level for switching to battery backup ($V_{DET\ BATT}$).

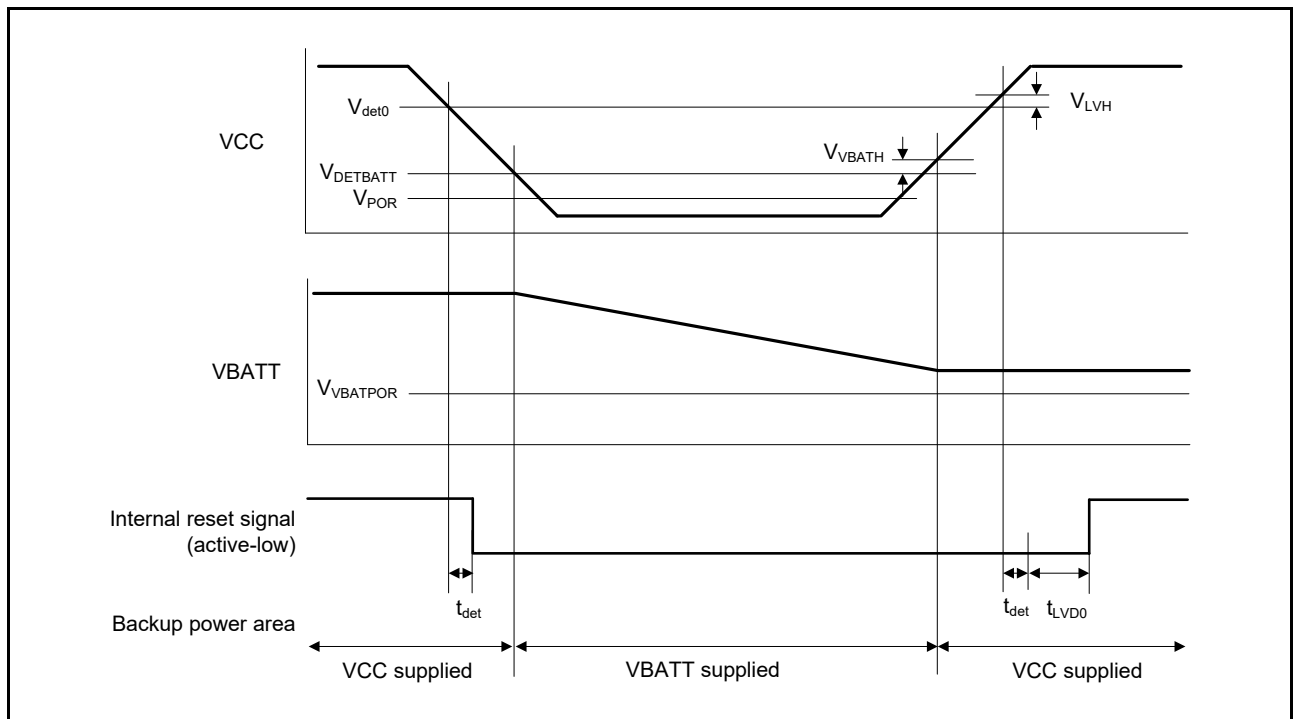

Figure 2.72 Power supply switching and LVD0 reset timing

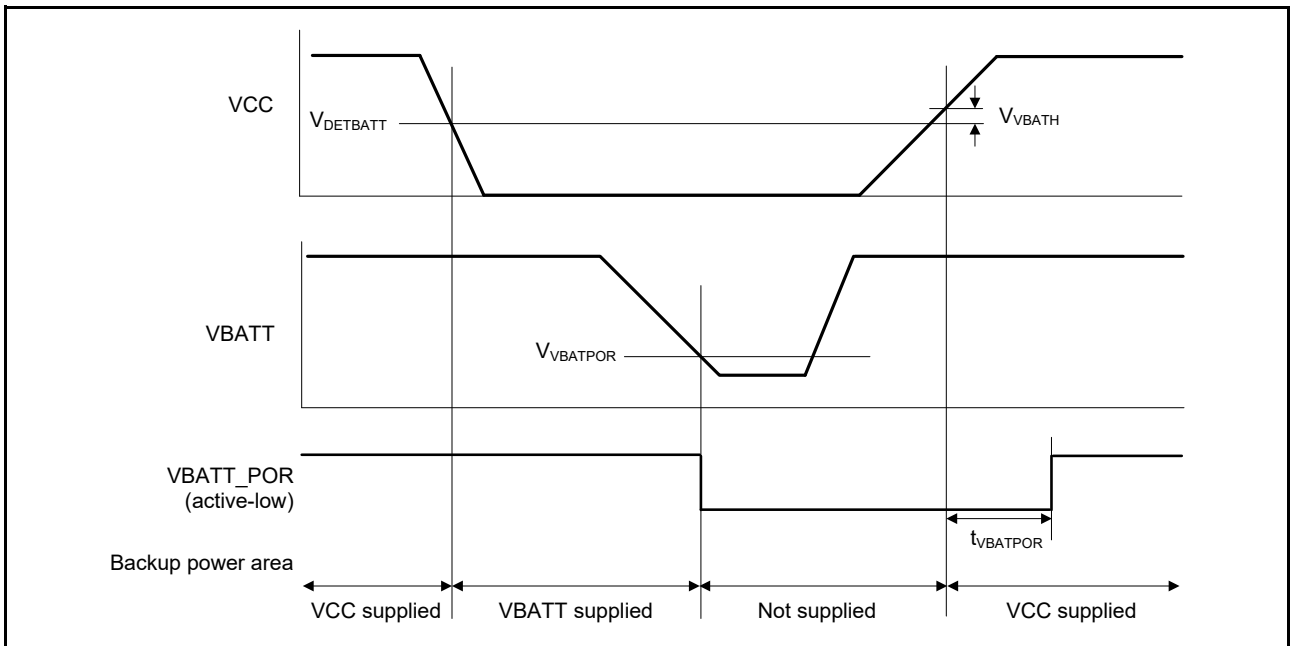

Figure 2.73 VBATT_POR reset timing

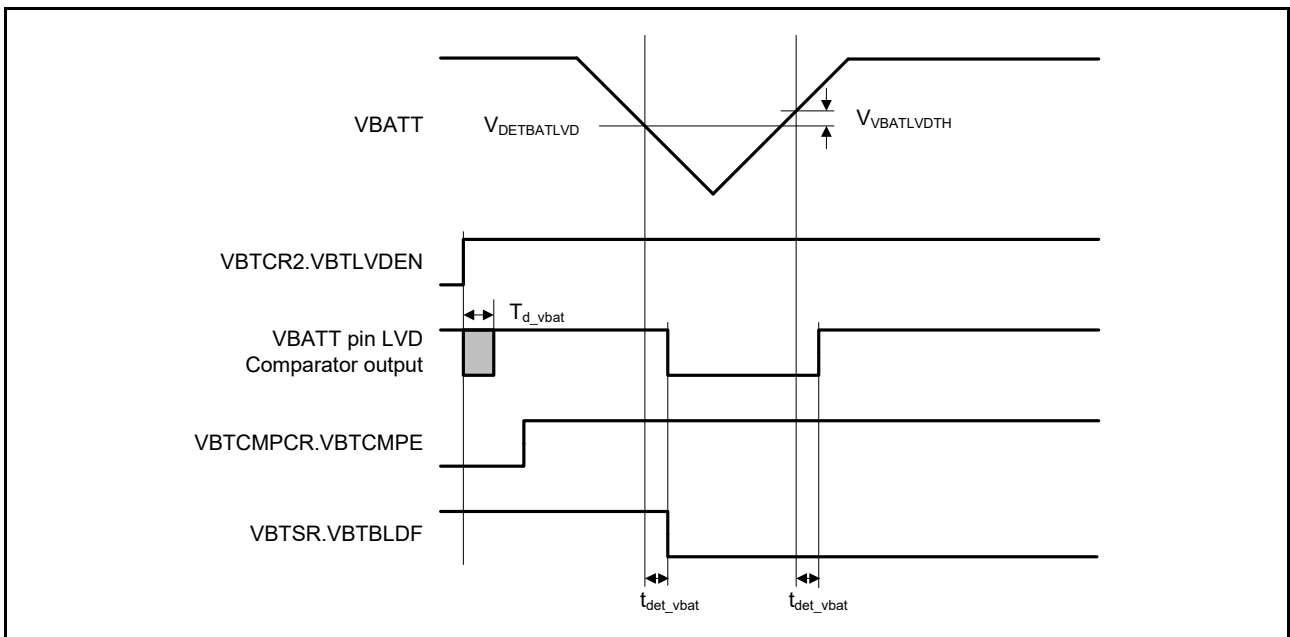

Figure 2.74 VBATT pin voltage detection circuit timing

Table 2.55 VBATT-I/O characteristics

Parameter			Symbol	Min	Typ	Max	Unit	Test conditions
VBATWIO nI/O output characteristics (n = 0)	VCC > V _{DETBATT}	VCC = 2.7 to 3.6 V	V _{OH}	VCC - 0.5	-	-		I _{OH} = -100 μA
			V _{OL}	-	-	0.5		I _{OL} = 100 μA
		VCC = V _{DETBATT} to 2.7 V	V _{OH}	VCC - 0.3	-	-		I _{OH} = -50 μA
			V _{OL}	-	-	0.3		I _{OL} = 50 μA
	VCC < V _{DETBATT}	VBATT = 2.7 to 3.6 V	V _{OH}	V _{BATT} - 0.5	-	-		I _{OH} = -100 μA
			V _{OL}	-	-	0.5		I _{OL} = 100 μA
		VBATT = 1.8 to 2.7 V	V _{OH}	V _{BATT} - 0.3	-	-		I _{OH} = -50 μA
			V _{OL}	-	-	0.3		I _{OL} = 50 μA

2.11 CTSU Characteristics

Table 2.56 CTSU characteristics

Conditions: VCC = AVCC0 = 1.8 to 3.6 V

Parameter	Symbol	Min	Typ	Max	Unit	Test conditions
External capacitance connected to TSCAP pin	C _{tscap}	9	10	11	nF	-
TS pin capacitive load	C _{base}	-	-	50	pF	-
Permissible output high current	ΣI _{oH}	-	-	-24	mA	When the mutual capacitance method is applied

2.12 Segment LCD Controller Characteristics

2.12.1 Resistance Division Method

[Static Display Mode]

Table 2.57 Resistance division method LCD characteristics (1)

Conditions: $V_{L4} \leq V_{CC} \leq 3.6$ V

Parameter	Symbol	Min	Typ	Max	Unit	Test conditions
LCD drive voltage	V_{L4}	2.0	-	VCC	V	-

[1/2 Bias Method, 1/4 Bias Method]

Table 2.58 Resistance division method LCD characteristics (2)

Conditions: $V_{L4} \leq V_{CC} \leq 3.6$ V

Parameter	Symbol	Min	Typ	Max	Unit	Test conditions
LCD drive voltage	V_{L4}	2.7	-	VCC	V	-

[1/3 Bias Method]

Table 2.59 Resistance division method LCD characteristics (3)

Conditions: $V_{L4} \leq V_{CC} \leq 3.6$ V

Parameter	Symbol	Min	Typ	Max	Unit	Test conditions
LCD drive voltage	V_{L4}	2.5	-	VCC	V	-

2.13 Comparator Characteristics

Table 2.60 ACMPLP characteristics

Conditions: $V_{CC} = 1.8$ to 3.6 V

Parameter		Symbol	Min	Typ	Max	Unit	Test conditions	
Reference voltage range	Standard mode	$IVREF_n$ ($n=0,1$)	VREF	0	-	$V_{CC}-1.4$	V	-
	Window mode*2	IVREF1	VREFH	1.4	-	VCC	V	-
		IVREF0	VREFL	0	-	$V_{CC}-1.4$	V	-
Input voltage range		V_I	0	-	VCC	V	-	
Internal reference voltage		-	1.36	1.44	1.50	V	-	
Output delay	High-speed mode	T_d	-	-	1.2	μ s	VCC = 3.0 Slew rate of input signal > 50 mV/ μ s	
	Low-speed mode		-	-	5	μ s		
	Window mode		-	-	2	μ s		
Offset voltage*1	High-speed mode	-	-	-	50	mV	-	
	Low-speed mode	-	-	-	40	mV	-	
	Window mode	-	-	-	60	mV	-	
Operation stabilization wait time		T_{cmp}	100	-	-	μ s	-	

Note 1. When 8-bit DAC output is used as the reference voltage, the offset voltage increases up to $2.5 \times V_{CC}/256$.

Note 2. In window mode, be sure to satisfy the following condition: $IVREF1 - IVREF0 \geq 0.2$ V.

2.14 OPAMP Characteristics

Table 2.61 OPAMP characteristics

Conditions: VCC = AVCC0 = 1.8 to 3.6 V (AVCC0 = VCC when VCC < 2.0 V)

Parameter	Symbol	Conditions	Min	Typ	Max	Unit	
Common mode input range	Vicm1	Low-power mode	0.2	-	AVCC0 – 0.5	V	
	Vicm2	High-speed mode	0.3	-	AVCC0 – 0.6	V	
Output voltage range	Vo1	Low-power mode	0.1	-	AVCC0 – 0.1	V	
	Vo2	High-speed mode	0.1	-	AVCC0 – 0.1	V	
Input offset voltage	Vioff	3 σ	-10	-	10	mV	
Open gain	Av		60	120	-	dB	
Gain-bandwidth (GB) product	GBW1	Low-power mode	-	0.04	-	MHz	
	GBW2	High-speed mode	-	1.7	-	MHz	
Phase margin	PM	CL = 20 pF	50	-	-	deg	
Gain margin	GM	CL = 20 pF	10	-	-	dB	
Equivalent input noise	Vnoise1	f = 1 kHz	Low-power mode	-	230	-	nV/ $\sqrt{\text{Hz}}$
	Vnoise2	f = 10 kHz		-	200	-	nV/ $\sqrt{\text{Hz}}$
	Vnoise3	f = 1 kHz	High-speed mode	-	90	-	nV/ $\sqrt{\text{Hz}}$
	Vnoise4	f = 2 kHz		-	70	-	nV/ $\sqrt{\text{Hz}}$
Power supply reduction ratio	PSRR		-	90	-	dB	
Common mode signal reduction ratio	CMRR		-	90	-	dB	
Stabilization wait time	Tstd1	CL = 20 pF Only operational amplifier is activated *1	Low-power mode	650	-	-	μs
	Tstd2		High-speed mode	13	-	-	μs
	Tstd3	CL = 20 pF Operational amplifier and reference current circuit are activated simultaneously	Low-power mode	650	-	-	μs
	Tstd4		High-speed mode	13	-	-	μs
Settling time	Tset1	CL = 20 pF	Low-power mode	-	-	750	μs
	Tset2		High-speed mode	-	-	13	μs
Slew rate	Tslew1	CL = 20 pF	Low-power mode	-	0.02	-	V/ μs
	Tslew2		High-speed mode	-	1.1	-	V/ μs
Load current	Iload1	Low power mode	-100	-	100	μA	
	Iload2	High-speed mode	-100	-	100	μA	
Load capacitance	CL		-	-	20	pF	

Note 1. When the operational amplifier reference current circuit is activated in advance.

2.15 Flash Memory Characteristics

2.15.1 Code Flash Memory Characteristics

Table 2.62 Code flash characteristics (1)

Parameter	Symbol	Min	Typ	Max	Unit	Test conditions
Reprogramming/erasure cycle*1	N _{PEC}	1000	-	-	Times	-
Data hold time	After 1000 times of N _{PEC}	t _{DRP}	20*2, *3	-	Year	T _a = +85°C

Note 1. The reprogram/erase cycle is the number of erasures for each block. When the reprogram/erase cycle is n times (n = 1,000), erasing can be done n times for each block. For instance, when 8-byte programming is performed 256 times for different addresses in 2-KB blocks, and then the entire block is erased, the reprogram/erase cycle is counted as one. However, programming the same address for several times as one erasure is not enabled (overwriting is prohibited).

Note 2. Characteristic when using the flash memory programmer and the self-programming library provided by Renesas Electronics.

Note 3. This result is obtained from reliability testing.

Table 2.63 Code flash characteristics (2)

High-speed operating mode

Conditions: VCC = 2.7 to 3.6 V

Parameter	Symbol	FCLK = 1 MHz			FCLK = 32 MHz			Unit	
		Min	Typ	Max	Min	Typ	Max		
Programming time	8-byte	t _{P8}	-	116	998	-	54	506	μs
Erasure time	2-KB	t _{E2K}	-	9.03	287	-	5.67	222	ms
Blank check time	8-byte	t _{BC8}	-	-	56.8	-	-	16.6	μs
	2-KB	t _{BC2K}	-	-	1899	-	-	140	μs
Erase suspended time		t _{SED}	-	-	22.5	-	-	10.7	μs
Startup area switching setting time		t _{SAS}	-	21.7	585	-	12.1	447	ms
Access window time		t _{AWS}	-	21.7	585	-	12.1	447	ms
OCD/serial programmer ID setting time		t _{OSIS}	-	21.7	585	-	12.1	447	ms
Flash memory mode transition wait time 1		t _{DIS}	2	-	-	2	-	-	μs
Flash memory mode transition wait time 2		t _{MS}	5	-	-	5	-	-	μs

Note: Does not include the time until each operation of the flash memory is started after instructions are executed by software.

Note: The lower-limit frequency of FCLK is 1 MHz during programming or erasing the flash memory. When using FCLK at below 4 MHz, the frequency can be set to 1 MHz, 2 MHz, or 3 MHz. A non-integer frequency such as 1.5 MHz cannot be set.

Note: The frequency accuracy of FCLK must be ±3.5%. Confirm the frequency accuracy of the clock source.

Table 2.64 Code flash characteristics (3)

Middle-speed operating mode

Conditions: VCC = 1.8 to 3.6 V, Ta = -40 to +85°C

Parameter		Symbol	FCLK = 1 MHz			FCLK = 8 MHz			Unit
			Min	Typ	Max	Min	Typ	Max	
Programming time	8-byte	t _{P8}	-	157	1411	-	101	966	μs
Erase time	2-KB	t _{E2K}	-	9.10	289	-	6.10	228	ms
Blank check time	8-byte	t _{BC8}	-	-	87.7	-	-	52.5	μs
	2-KB	t _{BC2K}	-	-	1930	-	-	414	μs
Erase suspended time		t _{SED}	-	-	32.7	-	-	21.6	μs
Startup area switching setting time		t _{SAS}	-	22.5	592	-	14.0	464	ms
Access window time		t _{AWS}	-	22.5	592	-	14.0	464	ms
OCD/serial programmer ID setting time		t _{OSIS}	-	22.5	592	-	14.0	464	ms
Flash memory mode transition wait time 1		t _{DIS}	2	-	-	2	-	-	μs
Flash memory mode transition wait time 2		t _{MS}	720	-	-	720	-	-	ns

Note: Does not include the time until each operation of the flash memory is started after instructions are executed by software.

Note: The lower-limit frequency of FCLK is 1 MHz during programming or erasing the flash memory. When using FCLK at below 4 MHz, the frequency can be set to 1 MHz, 2 MHz, or 3 MHz. A non-integer frequency such as 1.5 MHz cannot be set.

Note: The frequency accuracy of FCLK must be ±3.5%. Confirm the frequency accuracy of the clock source.

2.15.2 Data Flash Memory Characteristics

Table 2.65 Data flash characteristics (1)

Parameter		Symbol	Min	Typ	Max	Unit	Test conditions
Reprogramming/erasure cycle*1		N _{DPEC}	100000	1000000	-	Times	-
Data hold time	After 10000 times of N _{DPEC}	t _{DDRP}	20*2, *3	-	-	Year	Ta = +85°C
	After 100000 times of N _{DPEC}		5*2, *3	-	-	Year	
	After 1000000 times of N _{DPEC}		-	1*2, *3	-	Year	Ta = +25°C

Note 1. The reprogram/erase cycle is the number of erasure for each block. When the reprogram/erase cycle is n times (n = 100,000), erasing can be performed n times for each block. For instance, when 1-byte programming is performed 1,000 times for different addresses in 1-byte blocks, and then the entire block is erased, the reprogram/erase cycle is counted as one. However, programming the same address for several times as one erasure is not enabled. (overwriting is prohibited).

Note 2. Characteristics when using the flash memory programmer and the self-programming library provided by Renesas Electronics.

Note 3. These results are obtained from reliability testing.

Table 2.66 Data flash characteristics (2)

High-speed operating mode

Conditions: VCC = 2.7 to 3.6 V

Parameter		Symbol	FCLK = 4 MHz			FCLK = 32 MHz			Unit
			Min	Typ	Max	Min	Typ	Max	
Programming time	1-byte	t _{DP1}	-	52.4	463	-	42.1	387	μs
Erase time	1-KB	t _{DE1K}	-	8.98	286	-	6.42	237	ms
Blank check time	1-byte	t _{DBC1}	-	-	24.3	-	-	16.6	μs
	1-KB	t _{DBC1K}	-	-	1872	-	-	512	μs
Suspended time during erasing		t _{DSED}	-	-	13.0	-	-	10.7	μs
Data flash STOP recovery time		t _{DSTOP}	5	-	-	5	-	-	μs

Note: Does not include the time until each operation of the flash memory is started after instructions are executed by software.

Note: The lower-limit frequency of FCLK is 1 MHz during programming or erasing the flash memory. When using FCLK at below 4 MHz, the frequency can be set to 1 MHz, 2 MHz, or 3 MHz. A non-integer frequency such as 1.5 MHz cannot be set.

Note: The frequency accuracy of FCLK must be ±3.5%. Confirm the frequency accuracy of the clock source.

Table 2.67 Data flash characteristics (3)

Middle-speed operating mode

Conditions: VCC = 1.8 to 3.6 V, Ta = -40 to +85°C

Parameter	Symbol	FCLK = 4 MHz			FCLK = 8 MHz			Unit	
		Min	Typ	Max	Min	Typ	Max		
Programming time	1-byte	t _{DP1}	-	94.7	886	-	89.3	849	μs
Erase time	1-KB	t _{DE1K}	-	9.59	299	-	8.29	273	ms
Blank check time	1-byte	t _{DBC1}	-	-	56.2	-	-	52.5	μs
	1-KB	t _{DBC1K}	-	-	2.17	-	-	1.51	ms
Suspended time during erasing		t _{DSED}	-	-	23.0	-	-	21.7	μs
Data flash STOP recovery time		t _{DSTOP}	720	-	-	720	-	-	ns

Note: Does not include the time until each operation of the flash memory is started after instructions are executed by software.

Note: The lower-limit frequency of FCLK is 1 MHz during programming or erasing the flash memory. When using FCLK at below 4 MHz, the frequency can be set to 1 MHz, 2 MHz, or 3 MHz. A non-integer frequency such as 1.5 MHz cannot be set.

Note: The frequency accuracy of FCLK must be ±3.5%. Confirm the frequency accuracy of the clock source.

2.16 Joint Test Action Group (JTAG)

Table 2.68 JTAG (debug) characteristics (1)

Conditions: VCC = 2.4 to 3.6 V

Parameter	Symbol	Min	Typ	Max	Unit	Test conditions
TCK clock cycle time	t _{TCKcyc}	80	-	-	ns	Figure 2.75
TCK clock high pulse width	t _{TCKH}	35	-	-	ns	
TCK clock low pulse width	t _{TCKL}	35	-	-	ns	
TCK clock rise time	t _{TCKr}	-	-	5	ns	
TCK clock fall time	t _{TCKf}	-	-	5	ns	
TMS setup time	t _{TMSS}	16	-	-	ns	Figure 2.76
TMS hold time	t _{TMSH}	16	-	-	ns	
TDI setup time	t _{TDIS}	16	-	-	ns	
TDI hold time	t _{TDIH}	16	-	-	ns	
TDO data delay time	t _{TDOD}	-	-	70	ns	

Table 2.69 JTAG (debug) characteristics (2)

Conditions: VCC = 1.8 to 2.4 V

Parameter	Symbol	Min	Typ	Max	Unit	Test conditions
TCK clock cycle time	t _{TCKcyc}	250	-	-	ns	Figure 2.75
TCK clock high pulse width	t _{TCKH}	120	-	-	ns	
TCK clock low pulse width	t _{TCKL}	120	-	-	ns	
TCK clock rise time	t _{TCKr}	-	-	5	ns	
TCK clock fall time	t _{TCKf}	-	-	5	ns	
TMS setup time	t _{TMSS}	50	-	-	ns	Figure 2.76
TMS hold time	t _{TMSH}	50	-	-	ns	
TDI setup time	t _{TDIS}	50	-	-	ns	
TDI hold time	t _{TDIH}	50	-	-	ns	
TDO data delay time	t _{TDOD}	-	-	150	ns	

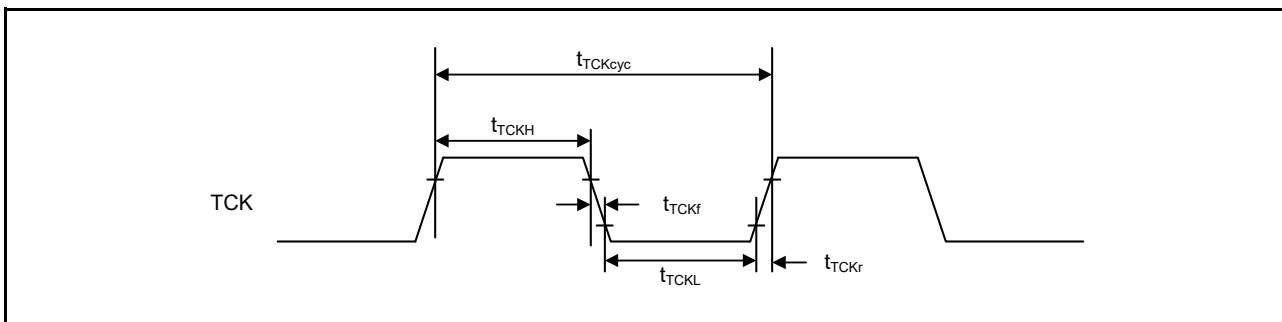

Figure 2.75 JTAG TCK timing

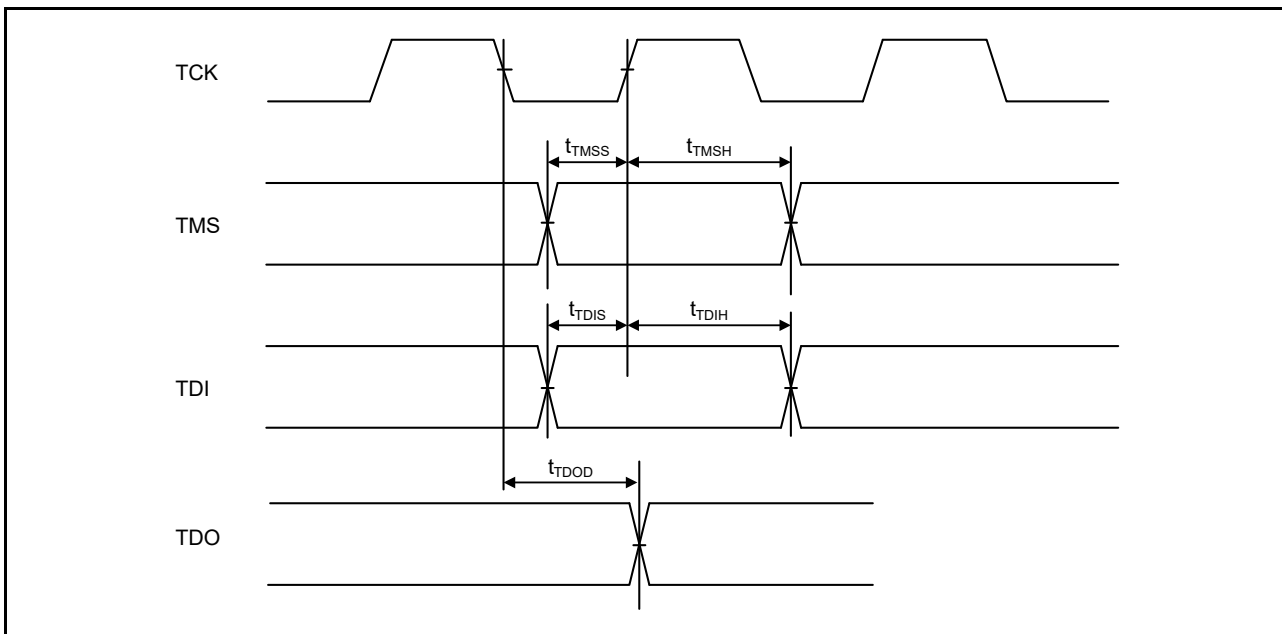

Figure 2.76 JTAG input/output timing

2.16.1 Serial Wire Debug (SWD)

Table 2.70 SWD characteristics (1)

Conditions: VCC = 2.4 to 3.6 V

Parameter	Symbol	Min	Typ	Max	Unit	Test conditions
SWCLK clock cycle time	$t_{SWCKcyc}$	80	-	-	ns	Figure 2.77
SWCLK clock high pulse width	t_{SWCKH}	35	-	-	ns	
SWCLK clock low pulse width	t_{SWCKL}	35	-	-	ns	
SWCLK clock rise time	t_{SWCKr}	-	-	5	ns	
SWCLK clock fall time	t_{SWCKf}	-	-	5	ns	
SWDIO setup time	t_{SWDS}	16	-	-	ns	Figure 2.78
SWDIO hold time	t_{SWDH}	16	-	-	ns	
SWDIO data delay time	t_{SWDD}	2	-	70	ns	

Table 2.71 SWD characteristics (2)

Conditions: VCC = 1.8 to 2.4 V

Parameter	Symbol	Min	Typ	Max	Unit	Test conditions
SWCLK clock cycle time	$t_{SWCKcyc}$	250	-	-	ns	Figure 2.77
SWCLK clock high pulse width	t_{SWCKH}	120	-	-	ns	
SWCLK clock low pulse width	t_{SWCKL}	120	-	-	ns	
SWCLK clock rise time	t_{SWCKr}	-	-	5	ns	
SWCLK clock fall time	t_{SWCKf}	-	-	5	ns	
SWDIO setup time	t_{SWDS}	50	-	-	ns	Figure 2.78
SWDIO hold time	t_{SWDH}	50	-	-	ns	
SWDIO data delay time	t_{SWDD}	2	-	150	ns	

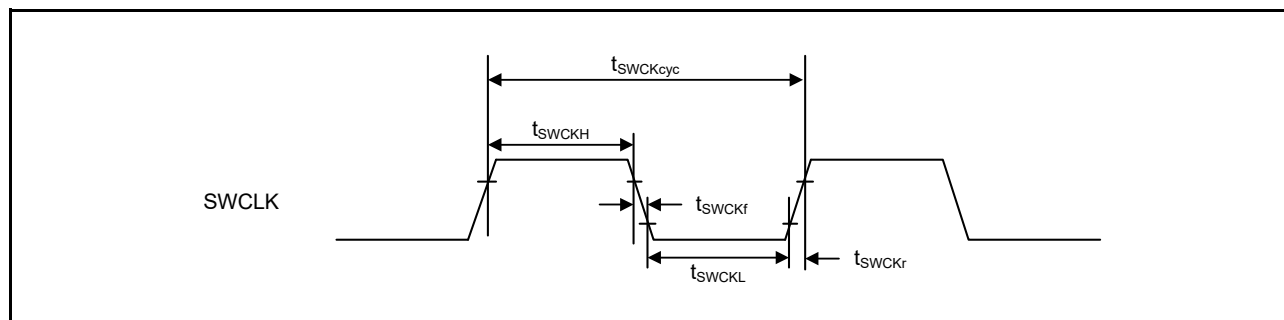

Figure 2.77 SWD SWCLK timing

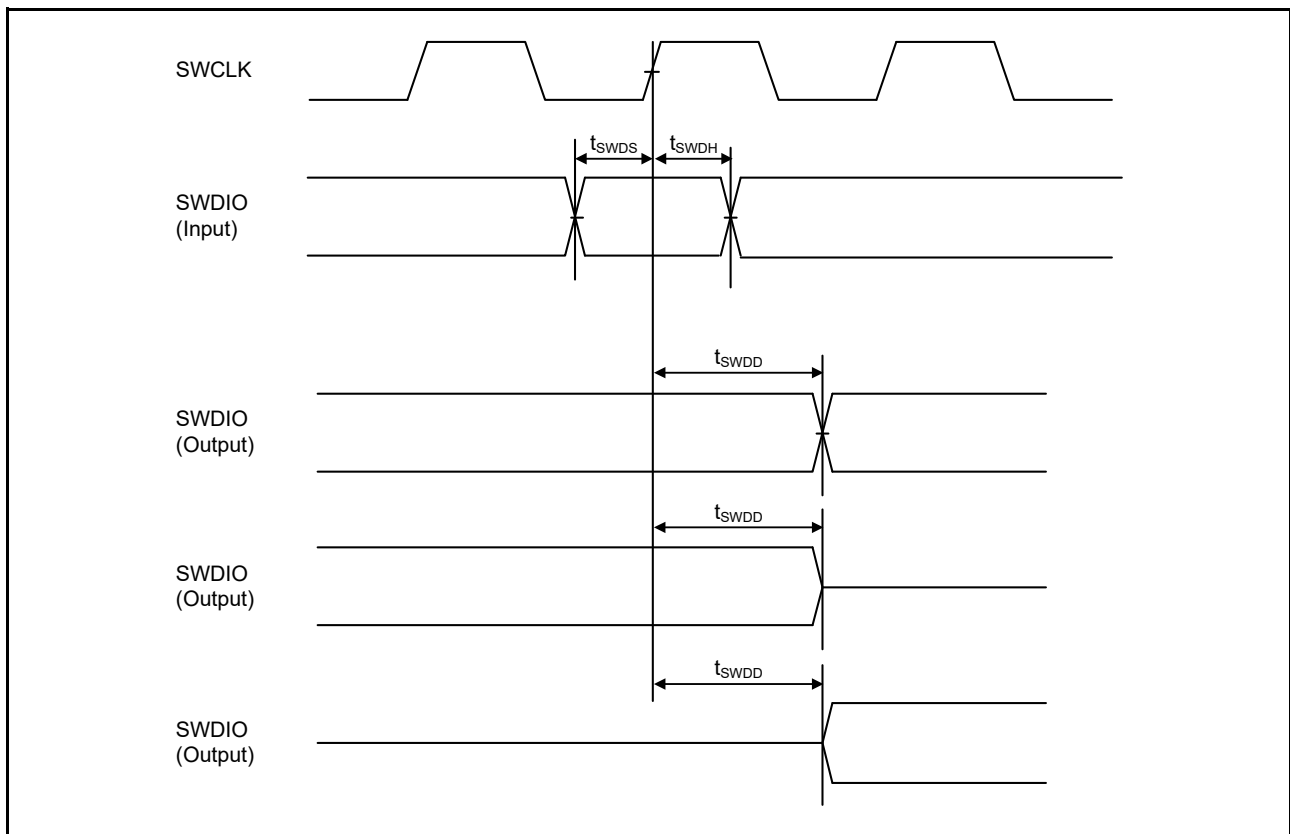

Figure 2.78 SWD input/output timing

2.17 BLE Characteristics

2.17.1 Transmission Characteristics

Table 2.72 Transmission Characteristics

Conditions: $V_{CC} = V_{CC_RF} = AV_{CC_RF} = 3.3\text{ V}$, $V_{SS} = V_{SS_RF} = 0\text{ V}$, $T_a = +25^\circ\text{C}$

Parameter	Symbol	Min	Typ	Max	Unit	Test conditions
Range of frequency	RF_{CF}	2402	-	2480	MHz	
Data rate	RF_{DATA_2M}	-	2	-	Mbps	
	RF_{DATA_1M}	-	1	-	Mbps	
	RF_{DATA_500k}	-	500	-	kbps	
	RF_{DATA_125k}	-	125	-	kbps	
Maximum transmitted output power	RF_{POWER}	-	0	2	dBm	0 dBm output mode
		-	4	6	dBm	4 dBm output mode
Output frequency error	RF_{TXFERR}	-10	-	10	ppm	*1

Note: The characteristics are based on pins and functions other than those for the BLE interface not being in use.

Note 1. This does not take frequency errors due to manufacturing irregularities, drift with temperature, or deterioration of the crystal over time into account.

2.17.2 Reception Characteristics (2 Mbps)

Table 2.73 Reception CharacteristicsConditions: VCC = VCC_RF = AVCC_RF = 3.3 V, VSS = VSS_RF = 0 V, T_a = +25°C

Item	Symbol	Min.	Typ.	Max.	Unit	Test Conditions	
Input frequency	RF _{RXFIN_2M}	2402	—	2480	MHz		
Maximum input level	RF _{LEVL_2M}	-10	4	—	dBm	*1	
Receiver sensitivity	RF _{STY_2M}	—	-92	—	dBm	*1	
Secondary emission strength	RF _{RXSP_2M}	—	-72	-57	dBm	30 MHz to 1 GHz	
		—	-54	-47	dBm	1 GHz to 12 GHz	
Co-channel rejection ratio	RF _{CCR_2M}	—	-8	—	dB	Prf = -67 dBm*1	
Adjacent channel rejection ratio	RF _{ADCR_2M}	—	2	—	dB	Prf = -67 dBm*1	±2 MHz
		—	35	—	dB		±4 MHz
		—	39	—	dB		±6 MHz
Blocking	RF _{BLK_2M}	—	-1	—	dBm	Prf = -67 dBm*1	30 MHz to 2000 MHz
		—	-25	—	dBm		2000 MHz to 2399 MHz
		—	-21	—	dBm		2484 MHz to 3000 MHz
		—	-10	—	dBm		> 3000 MHz
Allowable frequency deviation*2	RF _{RXFER_2M}	-120	—	120	ppm	*1	
RSSI accuracy	RF _{RSSIS_2M}	—	±4	—	dB	-70 dBm ≤ Prf ≤ -10 dBm	

Note: The characteristics are based on pins and functions other than those for the BLE interface not being in use.

Note 1. PER ≤ 30.8%, and a 37-byte payload

Note 2. Allowable range of difference between the center frequency for the RF input signals and the carrier frequency generated within the chip

2.17.3 Reception Characteristics (1 Mbps)

Table 2.74 Reception CharacteristicsConditions: VCC = VCC_RF = AVCC_RF = 3.3 V, VSS = VSS_RF = 0 V, T_a = +25°C

Item	Symbol	Min.	Typ.	Max.	Unit	Test Conditions	
Input frequency	RF _{RXFIN_1M}	2402	—	2480	MHz		
Maximum input level	RF _{LEVL_1M}	-10	4	—	dBm	*1	
Receiver sensitivity	RF _{STY_1M}	—	-95	—	dBm	*1	
Secondary emission strength	RF _{RXSP_1M}	—	-72	-57	dBm	30MHz to 1GHz	
		—	-54	-47	dBm	1GHz to 12GHz	
Co-channel rejection ratio	RF _{CCR_1M}	—	-7	—	dB	Prf = -67dBm*1	
Adjacent channel rejection ratio	RF _{ADCR_1M}	—	-1	—	dB	Prf = -67dBm*1	±1MHz
		—	34	—	dB		±2MHz
		—	35	—	dB		±3MHz
Blocking	RF _{BLK_1M}	—	0	—	dBm	Prf = -67dBm*1	30MHz to 2000MHz
		—	-24	—	dBm		2000MHz to 2399MHz
		—	-20	—	dBm		2484MHz to 3000MHz
		—	-4	—	dBm		> 3000MHz
Allowable frequency deviation*2	RF _{RXFER_1M}	-120	—	120	ppm	*1	
RSSI accuracy	RF _{RSSIS_1M}	—	±4	—	dB	-70dBm ≤ Prf ≤ -10dBm	

Note: The characteristics are based on pins and functions other than those for the BLE interface not being in use.

Note 1. PER ≤ 30.8%, and a 37-byte payload

Note 2. Allowable range of difference between the center frequency for the RF input signals and the carrier frequency generated within the chip

2.17.4 Reception Characteristics (500 kbps)

Table 2.75 Reception CharacteristicsConditions: VCC = VCC_RF = AVCC_RF = 3.3 V, VSS = VSS_RF = 0 V, T_a = +25°C

Item	Symbol	Min.	Typ.	Max.	Unit	Test Conditions	
Input frequency	RF _{RXFIN_500k}	2402	—	2480	MHz		
Maximum input level	RF _{LEVL_500k}	-10	4	—	dBm	*1	
Receiver sensitivity	RF _{STY_500k}	—	-100	—	dBm	*1	
Secondary emission strength	RF _{RXSP_500k}	—	-72	-57	dBm	30MHz to 1GHz	
		—	-54	-47	dBm	1GHz to 12GHz	
Co-channel rejection ratio	RF _{CCR_500k}	—	-4	—	dB	Prf = -72dBm*1	
Adjacent channel rejection ratio	RF _{ADCR_500k}	—	6	—	dB	Prf = -72dBm*1 ±1MHz	
		—	36	—	dB		±2MHz
		—	42	—	dB		±3MHz
Blocking	RF _{BLK_500k}	—	0	—	dBm	Prf = -72dBm*1 30MHz to 2000MHz	
		—	-23	—	dBm		2000MHz to 2399MHz
		—	-20	—	dBm		2484MHz to 3000MHz
		—	-7	—	dBm		> 3000MHz
Allowable frequency deviation*2	RF _{RXFER_500k}	-120	—	120	ppm	*1	
RSSI accuracy	RF _{RSSIS_500k}	—	±4	—	dB	-70dBm ≤ Prf ≤ -10dBm	

Note: The characteristics are based on pins and functions other than those for the BLE interface not being in use.

Note 1. PER ≤ 30.8%, and a 37-byte payload

Note 2. Allowable range of difference between the center frequency for the RF input signals and the carrier frequency generated within the chip

2.17.5 Reception Characteristics (125 kbps)

Table 2.76 Reception CharacteristicsConditions: VCC = VCC_RF = AVCC_RF = 3.3 V, VSS = VSS_RF = 0 V, T_a = +25°C

Item	Symbol	Min.	Typ.	Max.	Unit	Test Conditions	
Input frequency	RF _{RXFIN_125k}	2402	—	2480	MHz		
Maximum input level	RF _{LEVL_125k}	-10	4	—	dBm	*1	
Receiver sensitivity	RF _{STY_125k}	—	-105	—	dBm	*1	
Secondary emission strength	RF _{RXSP_125k}	—	-72	-57	dBm	30 MHz to 1 GHz	
		—	-54	-47	dBm	1 GHz to 12 GHz	
Co-channel rejection ratio	RF _{CCR_125k}	—	-2	—	dB	Prf = -79 dBm*1	
Adjacent channel rejection ratio	RF _{ADCR_125k}	—	12	—	dB	Prf = -79 dBm*1 ±1 MHz	
		—	39	—	dB		±2 MHz
		—	45	—	dB		±3 MHz
Blocking	RF _{BLK_125k}	—	0	—	dBm	Prf = -79 dBm*1 30 MHz to 2000 MHz	
		—	-23	—	dBm		2000 MHz to 2399 MHz
		—	-20	—	dBm		2484 MHz to 3000 MHz
		—	-1	—	dBm		> 3000MHz
Allowable frequency deviation*2	RF _{RXFER_125k}	-120	—	120	ppm	*1	
RSSI accuracy	RF _{RSSIS_125k}	—	±4	—	dB	T _a = +25°C, -70 dBm ≤ Prf ≤ -10 dBm	

Note: The characteristics are based on pins and functions other than those for the BLE interface not being in use.

Note 1. PER ≤ 30.8%, and a 37-byte payload

Note 2. Allowable range of difference between the center frequency for the RF input signals and the carrier frequency generated within the chip

Appendix 1. Package Dimensions

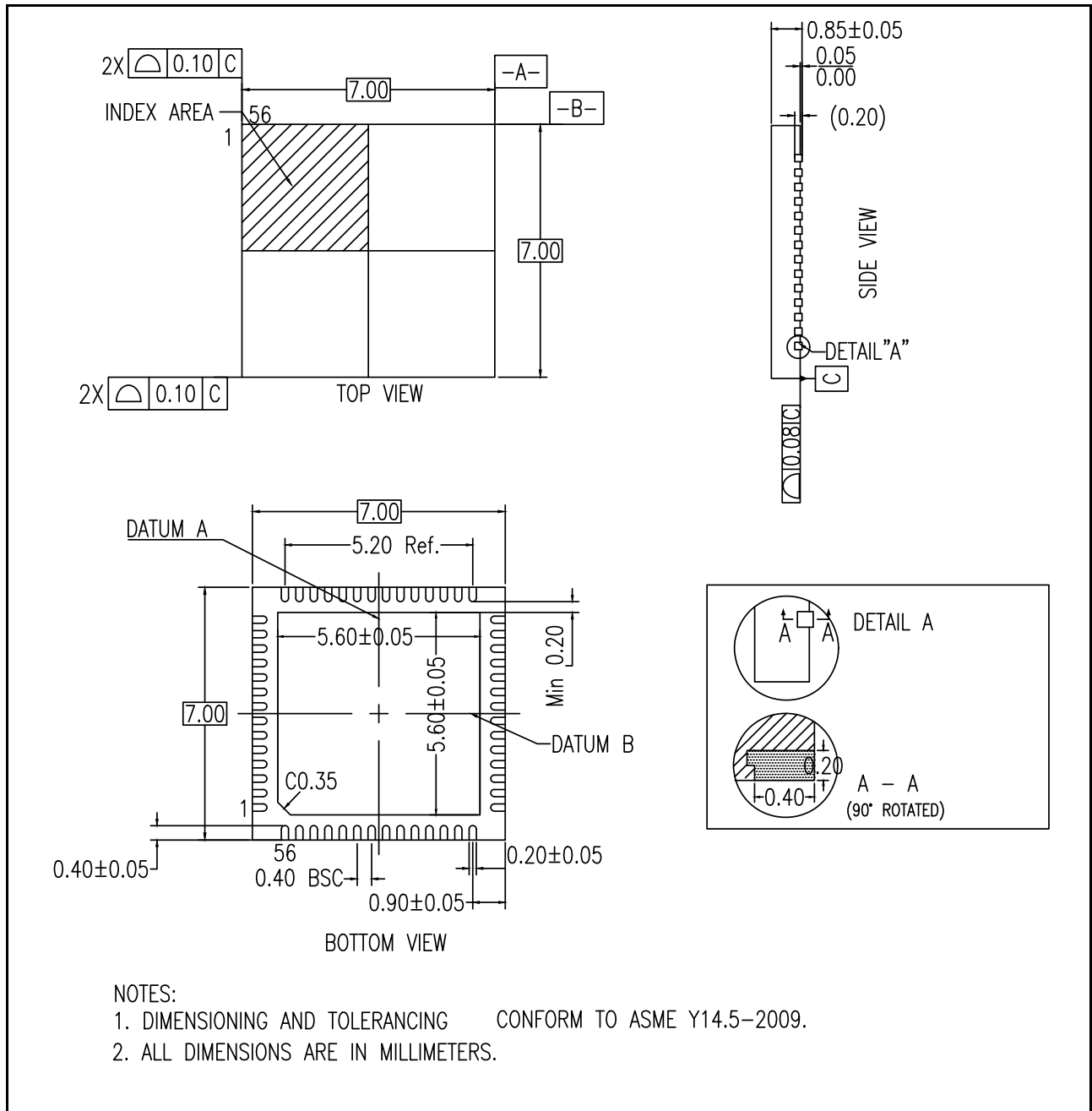

Figure 1.1 QFN 56-pin

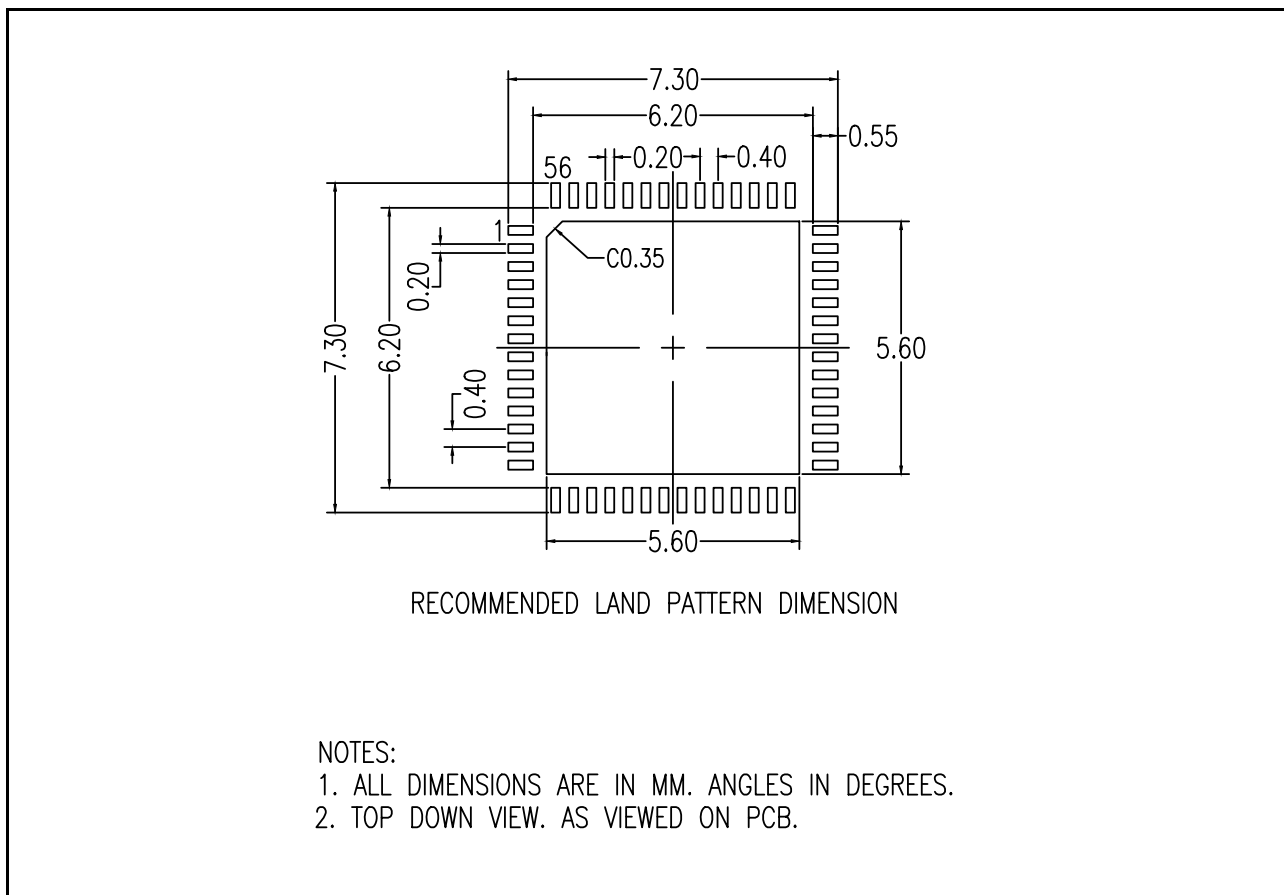

Figure 1.2 Land Pattern

Revision History	RA4W1 Group Datasheet
------------------	-----------------------

Rev.	Date	Summary
1.00	Mar 31, 2020	First release

Proprietary Notice

All text, graphics, photographs, trademarks, logos, artwork and computer code, collectively known as content, contained in this document is owned, controlled or licensed by or to Renesas, and is protected by trade dress, copyright, patent and trademark laws, and other intellectual property rights and unfair competition laws. Except as expressly provided herein, no part of this document or content may be copied, reproduced, republished, posted, publicly displayed, encoded, translated, transmitted or distributed in any other medium for publication or distribution or for any commercial enterprise, without prior written consent from Renesas.

Arm® and Cortex® are registered trademarks of Arm Limited. CoreSight™ is a trademark of Arm Limited.

CoreMark® is a registered trademark of the Embedded Microprocessor Benchmark Consortium.

Magic Packet™ is a trademark of Advanced Micro Devices, Inc.

Bluetooth® is a trademark of the Bluetooth SIG, Inc.

SuperFlash® is a registered trademark of Silicon Storage Technology, Inc. in several countries including the United States and Japan.

Other brands and names mentioned in this document may be the trademarks or registered trademarks of their respective holders.

RA4W1 Group Datasheet

Publication Date: Rev.1.00 Mar 31, 2020

Published by: Renesas Electronics Corporation

Notice

1. Descriptions of circuits, software and other related information in this document are provided only to illustrate the operation of semiconductor products and application examples. You are fully responsible for the incorporation or any other use of the circuits, software, and information in the design of your product or system. Renesas Electronics disclaims any and all liability for any losses and damages incurred by you or third parties arising from the use of these circuits, software, or information.
2. Renesas Electronics hereby expressly disclaims any warranties against and liability for infringement or any other claims involving patents, copyrights, or other intellectual property rights of third parties, by or arising from the use of Renesas Electronics products or technical information described in this document, including but not limited to, the product data, drawings, charts, programs, algorithms, and application examples.
3. No license, express, implied or otherwise, is granted hereby under any patents, copyrights or other intellectual property rights of Renesas Electronics or others.
4. You shall not alter, modify, copy, or reverse engineer any Renesas Electronics product, whether in whole or in part. Renesas Electronics disclaims any and all liability for any losses or damages incurred by you or third parties arising from such alteration, modification, copying or reverse engineering.
5. Renesas Electronics products are classified according to the following two quality grades: "Standard" and "High Quality". The intended applications for each Renesas Electronics product depends on the product's quality grade, as indicated below.
"Standard": Computers; office equipment; communications equipment; test and measurement equipment; audio and visual equipment; home electronic appliances; machine tools; personal electronic equipment; industrial robots; etc.
"High Quality": Transportation equipment (automobiles, trains, ships, etc.); traffic control (traffic lights); large-scale communication equipment; key financial terminal systems; safety control equipment; etc.
Unless expressly designated as a high reliability product or a product for harsh environments in a Renesas Electronics data sheet or other Renesas Electronics document, Renesas Electronics products are not intended or authorized for use in products or systems that may pose a direct threat to human life or bodily injury (artificial life support devices or systems; surgical implantations; etc.), or may cause serious property damage (space system; undersea repeaters; nuclear power control systems; aircraft control systems; key plant systems; military equipment; etc.). Renesas Electronics disclaims any and all liability for any damages or losses incurred by you or any third parties arising from the use of any Renesas Electronics product that is inconsistent with any Renesas Electronics data sheet, user's manual or other Renesas Electronics document.
6. When using Renesas Electronics products, refer to the latest product information (data sheets, user's manuals, application notes, "General Notes for Handling and Using Semiconductor Devices" in the reliability handbook, etc.), and ensure that usage conditions are within the ranges specified by Renesas Electronics with respect to maximum ratings, operating power supply voltage range, heat dissipation characteristics, installation, etc. Renesas Electronics disclaims any and all liability for any malfunctions, failure or accident arising out of the use of Renesas Electronics products outside of such specified ranges.
7. Although Renesas Electronics endeavors to improve the quality and reliability of Renesas Electronics products, semiconductor products have specific characteristics, such as the occurrence of failure at a certain rate and malfunctions under certain use conditions. Unless designated as a high reliability product or a product for harsh environments in a Renesas Electronics data sheet or other Renesas Electronics document, Renesas Electronics products are not subject to radiation resistance design. You are responsible for implementing safety measures to guard against the possibility of bodily injury, injury or damage caused by fire, and/or danger to the public in the event of a failure or malfunction of Renesas Electronics products, such as safety design for hardware and software, including but not limited to redundancy, fire control and malfunction prevention, appropriate treatment for aging degradation or any other appropriate measures. Because the evaluation of microcomputer software alone is very difficult and impractical, you are responsible for evaluating the safety of the final products or systems manufactured by you.
8. Please contact a Renesas Electronics sales office for details as to environmental matters such as the environmental compatibility of each Renesas Electronics product. You are responsible for carefully and sufficiently investigating applicable laws and regulations that regulate the inclusion or use of controlled substances, including without limitation, the EU RoHS Directive, and using Renesas Electronics products in compliance with all these applicable laws and regulations. Renesas Electronics disclaims any and all liability for damages or losses occurring as a result of your noncompliance with applicable laws and regulations.
9. Renesas Electronics products and technologies shall not be used for or incorporated into any products or systems whose manufacture, use, or sale is prohibited under any applicable domestic or foreign laws or regulations. You shall comply with any applicable export control laws and regulations promulgated and administered by the governments of any countries asserting jurisdiction over the parties or transactions.
10. It is the responsibility of the buyer or distributor of Renesas Electronics products, or any other party who distributes, disposes of, or otherwise sells or transfers the product to a third party, to notify such third party in advance of the contents and conditions set forth in this document.
11. This document shall not be reprinted, reproduced or duplicated in any form, in whole or in part, without prior written consent of Renesas Electronics.
12. Please contact a Renesas Electronics sales office if you have any questions regarding the information contained in this document or Renesas Electronics products.
(Note 1) "Renesas Electronics" as used in this document means Renesas Electronics Corporation and also includes its directly or indirectly controlled subsidiaries.
(Note 2) "Renesas Electronics product(s)" means any product developed or manufactured by or for Renesas Electronics.

(Rev.4.0-1 November 2017)



SALES OFFICES

Renesas Electronics Corporation

<http://www.renesas.com>

Refer to "<http://www.renesas.com/>" for the latest and detailed information.

Renesas Electronics Corporation

TOYOSU FORESIA, 3-2-24 Toyosu, Koto-ku, Tokyo 135-0061, Japan

Renesas Electronics America Inc.

1001 Murphy Ranch Road, Milpitas, CA 95035, U.S.A.
Tel: +1-408-432-8888, Fax: +1-408-434-5351

Renesas Electronics Canada Limited

9251 Yonge Street, Suite 8309 Richmond Hill, Ontario Canada L4C 9T3
Tel: +1-905-237-2004

Renesas Electronics Europe GmbH

Arcadiastrasse 10, 40472 Düsseldorf, Germany
Tel: +49-211-6503-0, Fax: +49-211-6503-1327

Renesas Electronics (China) Co., Ltd.

Room 101-T01, Floor 1, Building 7, Yard No. 7, 8th Street, Shangdi, Haidian District, Beijing 100085, China
Tel: +86-10-8235-1155, Fax: +86-10-8235-7679

Renesas Electronics (Shanghai) Co., Ltd.

Unit 301, Tower A, Central Towers, 555 Langao Road, Putuo District, Shanghai 200333, China
Tel: +86-21-2226-0888, Fax: +86-21-2226-0999

Renesas Electronics Hong Kong Limited

Unit 1601-1611, 16/F., Tower 2, Grand Century Place, 193 Prince Edward Road West, Mongkok, Kowloon, Hong Kong
Tel: +852-2265-6688, Fax: +852 2886-9022

Renesas Electronics Taiwan Co., Ltd.

13F, No. 363, Fu Shing North Road, Taipei 10543, Taiwan
Tel: +886-2-8175-9600, Fax: +886 2-8175-9670

Renesas Electronics Singapore Pte. Ltd.

80 Bendemeer Road, Unit #06-02 Hyflux Innovation Centre, Singapore 339949
Tel: +65-6213-0200, Fax: +65-6213-0300

Renesas Electronics Malaysia Sdn.Bhd.

Unit No 3A-1 Level 3A Tower 8 UOA Business Park, No 1 Jalan Pengaturcara U1/51A, Seksyen U1, 40150 Shah Alam, Selangor, Malaysia
Tel: +60-3-5022-1288, Fax: +60-3-5022-1290

Renesas Electronics India Pvt. Ltd.

No.777C, 100 Feet Road, HAL 2nd Stage, Indiranagar, Bangalore 560 038, India
Tel: +91-80-67208700

Renesas Electronics Korea Co., Ltd.

17F, KAMCO Yangjae Tower, 262, Gangnam-daero, Gangnam-gu, Seoul, 06265 Korea
Tel: +82-2-558-3737, Fax: +82-2-558-5338

Renesas RA Family
RA4W1 Group

Looking for pricing, stock, or lifecycle information?

Click below to explore more details on WIN SOURCE:

- ⊖ [View R7FA4W1AD2CNG#AA0 on WIN SOURCE](#)
- ⊖ [Renesas Electronics America Information](#)

Optimize Your Supply Chain with WIN SOURCE Solutions

- ✓ Global Sourcing Solution
- ✓ Obsolete Management
- ✓ Cost Control Management
- ✓ Shortage Management
- ✓ Alternative Solution
- ✓ Excess Inventory Management